

Manopla Rotativa para Montagem em Painel MPW25 (RMMP/RMMP-E)
Door Coupling Rotary Handle MPW25 (RMMP/RMMP-E)
Manija Rotativa para Puerta de Tableros (RMMP/RMMP-E)
Türkupplungsgriff MPW25 (RMMP/RMMP-E)

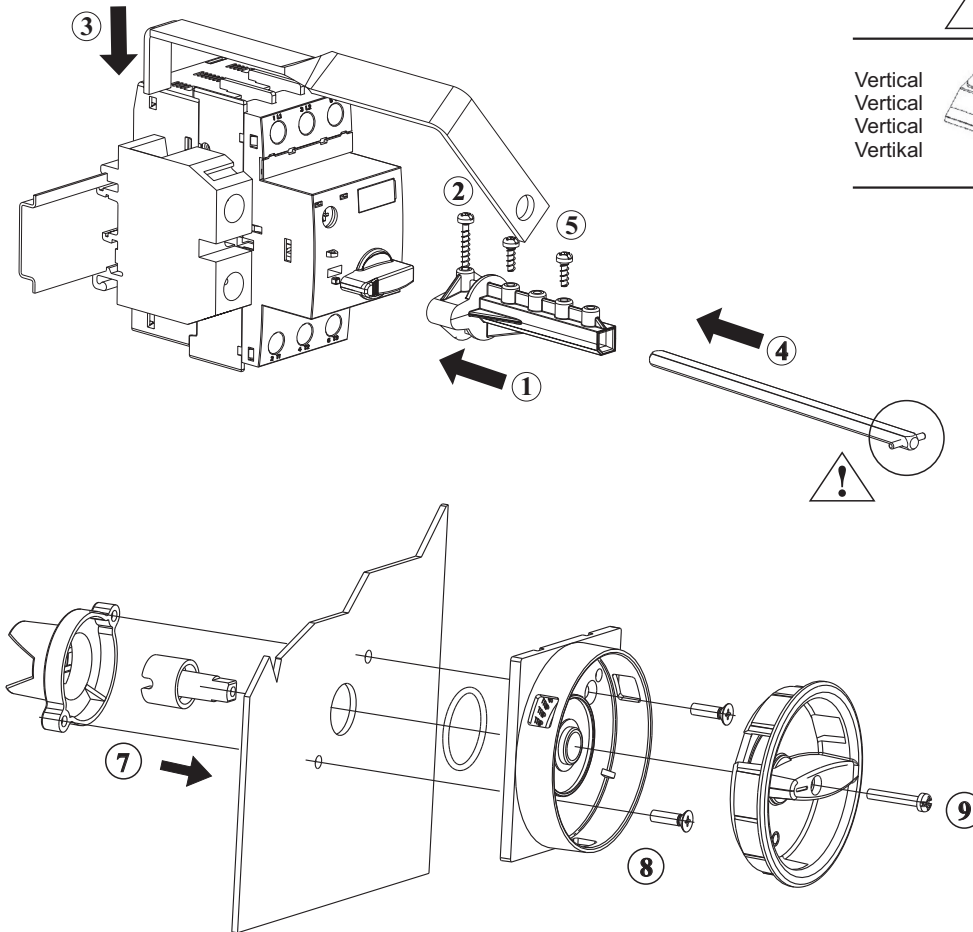

Montagem MPW25 / MPW25 Assembly
 Montaje MPW25 / Einbaulage MPW25

Vertical
 Vertical
 Vertical
 Vertikal

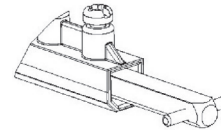

Horizontal
 Horizontal
 Horizontal
 Horizontal

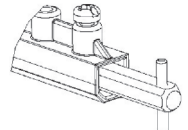

Furação da porta do painel
 Drilling the panel door
 Agujero en la puerta de tableros
 Bohren der Schaltschranktür

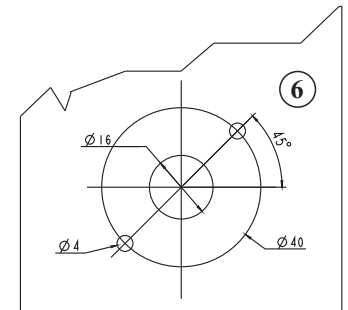

Dimensão mínima para corte do eixo (mm)
 Minimum dimension for cut the shaft (mm)
 Dimensiones mínimas para corte del eje (mm)
 Mindestmaß für das Kürzen der Achse (mm)

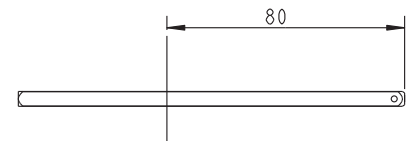

Dimensões
 Dimensions
 Dimensiones
 Maße

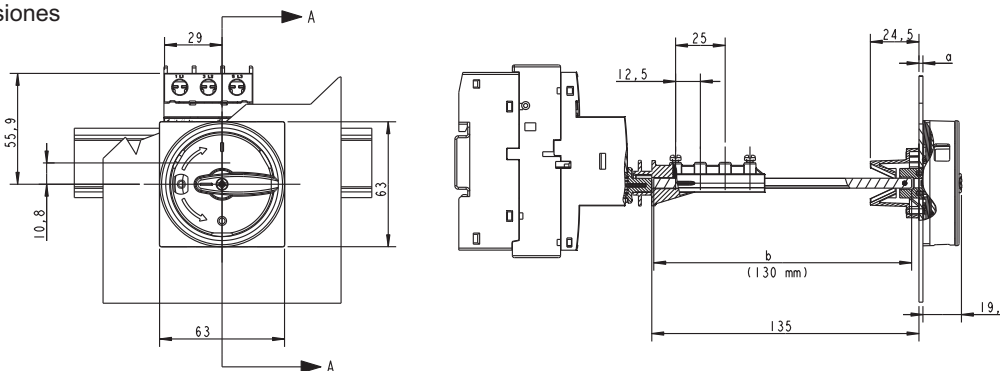

Espessura da porta do painel Panel door thickness Espesorde la puerta del tablero Dicke der Tür	
a (mm)	1,0 ... 3,5

b (mm)	Possibilidade de ajuste Possible adjustment Posibilidad del ajuste Mögliche Einstellung
130	130 ... 155
330	330 ... 355

- Atenção / Warning / Atención / Warnung

A porta do painel só poderá ser aberta com o MPW25 na posição OFF
 The panel door can be opened only with the MPW25 in the OFF position
 Apertura de la puerta del tablero solamente en la posición desconectado
 die Schaltschranktür kann nur bei ausgeschaltetem MPW25 geöffnet werden

WEG Indústrias Ltda. - ACIONAMENTOS

Av. Prefeito Waldemar Grubba, 3000
 89256-900 - Jaraguá do Sul - SC - BRASIL
 Tel. (0xx47) 3372-4000 - FAX (0xx47) 3372-4050
 www.weg.net - e-mail: wa-mkt@weg.net
 São Paulo: TEL (0xx11) 5053-2300 - FAX (0xx11) 5052-4212
 CNPJ 07.175.725/0004-02