

# Summary

---

**Company Profile**

**1**

---

**Technical Information**

**2**

---

**Nylon Cable Chains**

**3**

---

**Steel Cable Chains**

**4**

---

**Cable Chain Cables**

**5**

---

**Enquiry and Order Form**

**6**

---

**Overview of Products Range**

**7**

---

# Brevetti Stendalto

1



Brevetti Stendalto is the name of the Company founded almost 40 years ago when a highly dynamic new demand, emerging from the boost of automation concepts, was spreading over the most developed industrialized countries.

At that time, Mr. Giovanni Mauri (President and founder of Brevetti Stendalto) designed and started proposing nylon cable chains to be applied where steel cable chains were too heavy and expensive to fulfil customers' needs.

Looking beyond, he got off more than a new line of products, he gave the original profile to the Company: a successful collection of innovation, technical support, pragmatic solutions and products with the best cost & benefit ratio, able to give customers a real added value to the long-term partnership with Brevetti.

The constant evolution of the Company is presently borne through a wide range of plastic, steel and stainless steel chains for all kinds of applications, new modern premises in Monza and Mesero, branches in France and Germany and a consolidated worldwide sales network.

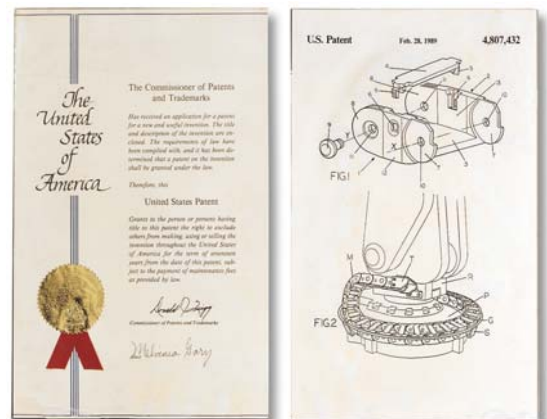

1989  
Patent for the circular nylon cable chain.

Glancing at short-term future, Brevetti is working on three main directions: development of customized chains for special projects, support to buyers and designers to make their choices more efficient through a real problem-solving approach, and extension of our range of standard products,

The latter, in particular, is necessary to meet the newest market requirements for higher performances with acceptable costs. Brevetti's greater and greater experience in all industrial sectors makes it easier.

We in Brevetti believe that some special applications, such as offshore platforms and harbour cranes, must be faced with non-ordinary means. That is why we decided to give our customers the support of a "Special Projects Division" available to study customized solutions all over the world.

We always keep in mind that our customers have to be "free to project". This is Brevetti Stendalto's philosophy, and to empower it, we can offer our "Total Chain System", a new concept of cable chains completely finished with extra flexible cables and connectors. From the customer's point of view, it means saving costs due to wiring, assembling and installation time, reducing possible problems, and being certain to choose components of the highest reliability available on the market.

So, let's keep on growing together, still going ahead.



Chain testing rig for long travel. Tests at 8 m/s for 130 m travels.

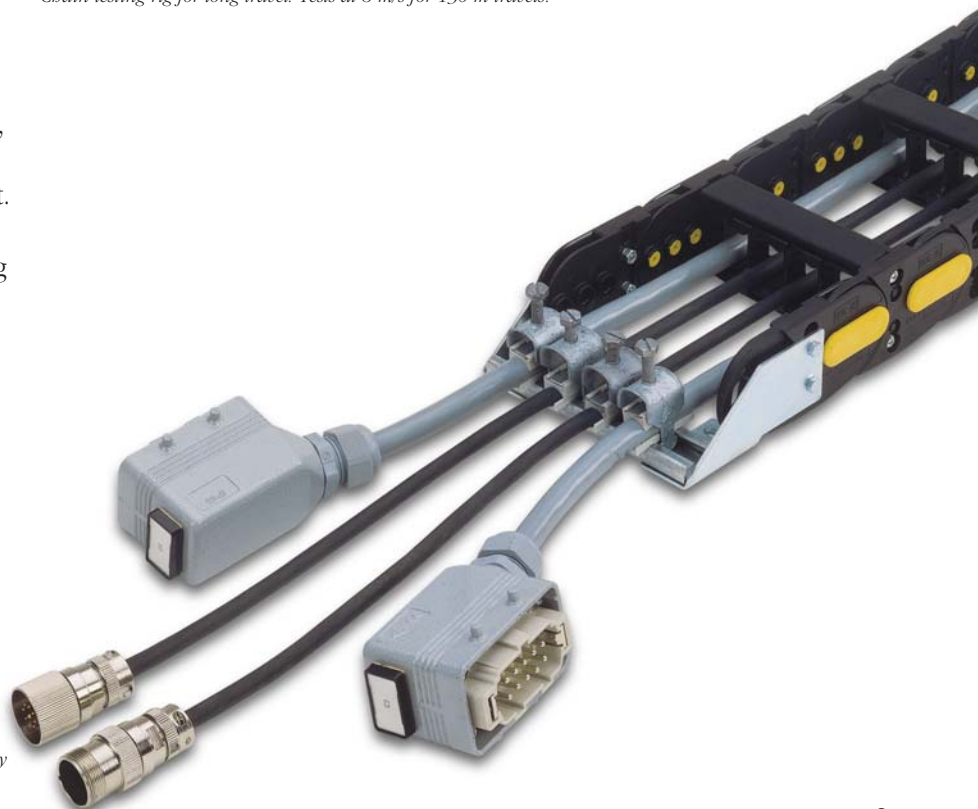

Chain complete with cables and connectors: Plug & Play solution.

# Versatile Automation

1



*Production moulds are manufactured using modern CNC machine-tools.*



Each aspect of production, whether it be the preparation of moulds and their subsequent shaping or component manufacture and assembly, is monitored closely.

The Company endeavours to adopt the most up-to-date technology available. Considerable resources are invested into this, ensuring the highest standard of products on the market. Production moulds are manufactured using modern CNC machine-tools.

Mould of Light series cable chain. Brevetti Stendalto manufacturing process (internal moulding department and complete automated assembly lines) ensures quality and short delivery times.

Complete automated assembly lines ensure a high standard of quality chains.

## Products

**Nylon cable chains**

**Steel cable chains**

**Cable chain cables**



*Completely automated assembly lines ensure a high standard of quality chains.*



*Production moulds are manufactured using modern CNC machine-tools.*

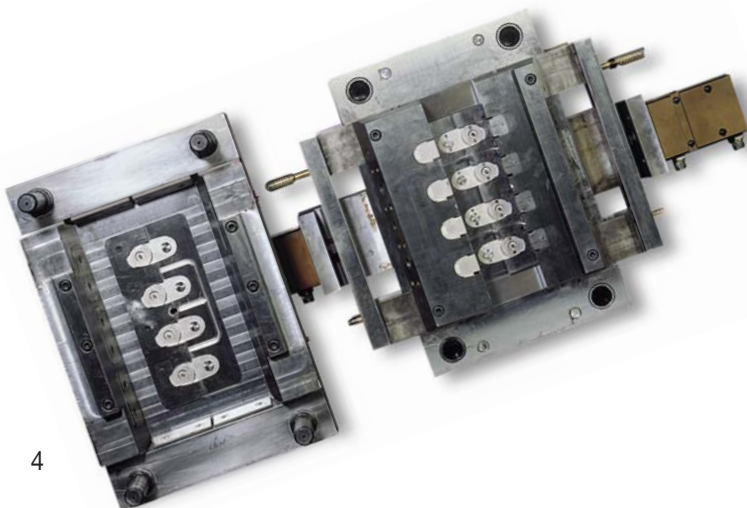

# UNI EN ISO 9001:2000

In Brevetti Stendalto the quality is a result of our activities.  
To be a success and reference company Brevetti Stendalto strives for:

- full satisfaction of our customers ever increasing requests.
- continuing improvement of our company capacities.
- valorization and improvement of our human resources.
- involvement of all our staff in striving for quality assurance.
- careful selection of suppliers and involvement of these in our quality process.
- standardization of production, to assure competitive products.
- innovative products to meet the markets ever increasing requests.
- fast assistance to guarantee the customers reduced breakdown time.



Certificate  
UNI EN ISO 9001:2000

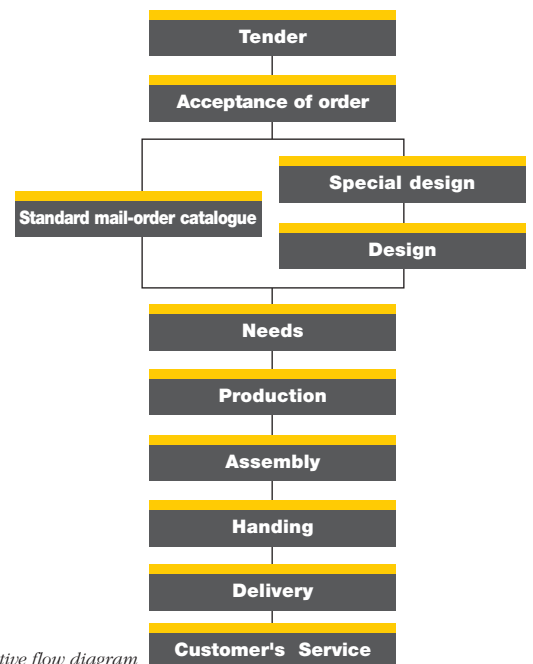

Operative flow diagram

# The Way to Automation

1

Past experience acquired in the marketing of machine tools has prompted Brevetti Stendalto to diversify its proposals. Today, thanks to products from Brevetti Stendalto, present day problems in cable and tubing protection are solved in the best possible way.

Our products can be found in many applications, especially in the field of automated production, for example in industrial robots and machinery for crafting metal, wood and stone.



*Welding robot equipped with nylon chains.*



*Steel chain BS 3000.*



*SR 318 for long travel distance on a crane application.*



*Machine tools equipped with Heavy series cable chains.*



*Circular nylon chains on welding robots.*



*Wending robot equipped with a nylon cable chain type SR510 and guide support.*

Brevetti Stendalto products are used in many, very different, fields of application. We have experience ranging from packaging & automated handling, storage and transportation to providing solutions used in all fields of engineering like mining, offshore drilling, building, in steel works, ports and terminals.

We are always close to our Clients. Our distribution network, consisting of manufacturing plants, sales companies and warehouses, is spread across the entire world.



*BS 3500 steel chains with supporting frame applied to De Icing's equipment at München airport (Germany).*



*SR310 plastic chains and BS4500 stainless steel chains applied to "Oresund Bridge" between Sweden and Denmark.*

# Always Available

1

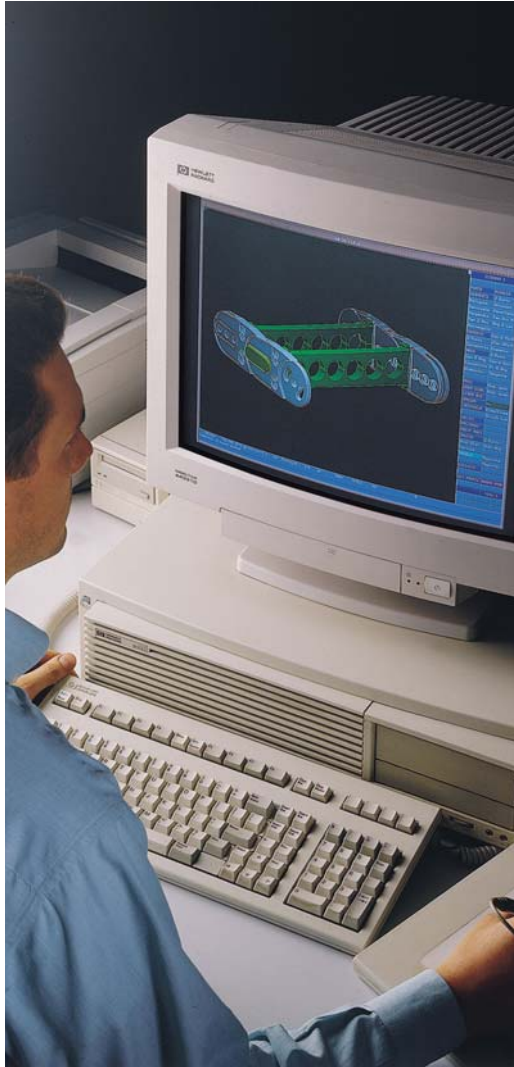

*All cable chains are studied with the support of CAD-CAM systems.*

Each Client is important to Brevetti Stendalto regardless of the needs and the size of his request. Brevetti Stendalto offers professional support for assessing the Client's needs, consultation inherent to the choice of products, design of new products, design of a new product and visiting *client* installations.

## Technical Office

Competence and availability are the key words in technical assistance.

All technical needs and installation characteristic requests are carefully evaluated and verified with the support of informatics and CAD-3D projection that will solve the problems as they arrive.



*Computerised stock management and control system ensures short delivery times.*



*Brevetti Stendalto's technical office is the reference-point for information.*





To offer a rapid and always updated commercial and technical information, Brevetti Stendalto has introduced a new web-site **www.brevettistendalto.it** in which all necessary info is available for fast chain selection and easy downloads of chain characteristics.

For direct technical support, please contact our Technical Dept. at **tekno@brevettistendalto.it** which will assist you with specific technical questions, customized chain solution, CAD drawings, etc.

*Brevetti Stendalto is always close to customers, ensuring assistance from project analysis up to final installation and after sales support.*





Russell  
Electronics

R 150

Prepared  
Specialist

Russell  
Electronics

Prepared  
Specialist

# Technical Information

Necessary data to determine the type of cable chain	page 12
Placement of cables/hoses in the cable chain	page 13

## Mounting Variations

Chains placed horizontally	page 14
Chains placed vertically	page 16
Chains with circular motion	page 17

## Going Further

Self-supporting capacity	page 18
Determining the length of the chain	page 19
Vertical applications	page 20
Horizontal applications (side-mounted)	page 21
Long horizontal travel distances	page 22
Guide channels for sliding chains	page 24
How to install the cable chains in the guide channel	page 25
Rotating horizontally	page 26
Rotation with Robot type chains	page 28
Support roller units	page 30
Way of mounting end brackets	page 31
Guide channel	page 32
Split cross pieces from the Heavy/Sliding series	page 33
Materials used	page 34



# Necessary Data to Determine the Type of Cable Chain

The choice of cable chain should not only be based on a mathematical calculation of certain factors but should consider and analyse carefully all the available data. The following information will be provide a basic help in making the right decision.

Thanks to thirty years of experience in this sector we have a highly competent technical staff which is at your disposal to help solve any problem relating to the use of cables in any kind of application.

To request a personalised project please fill out the form found on page 201. It will be a pleasure for us to find an immediate solution to your problem.

2

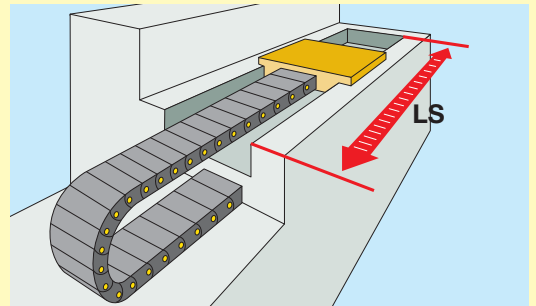
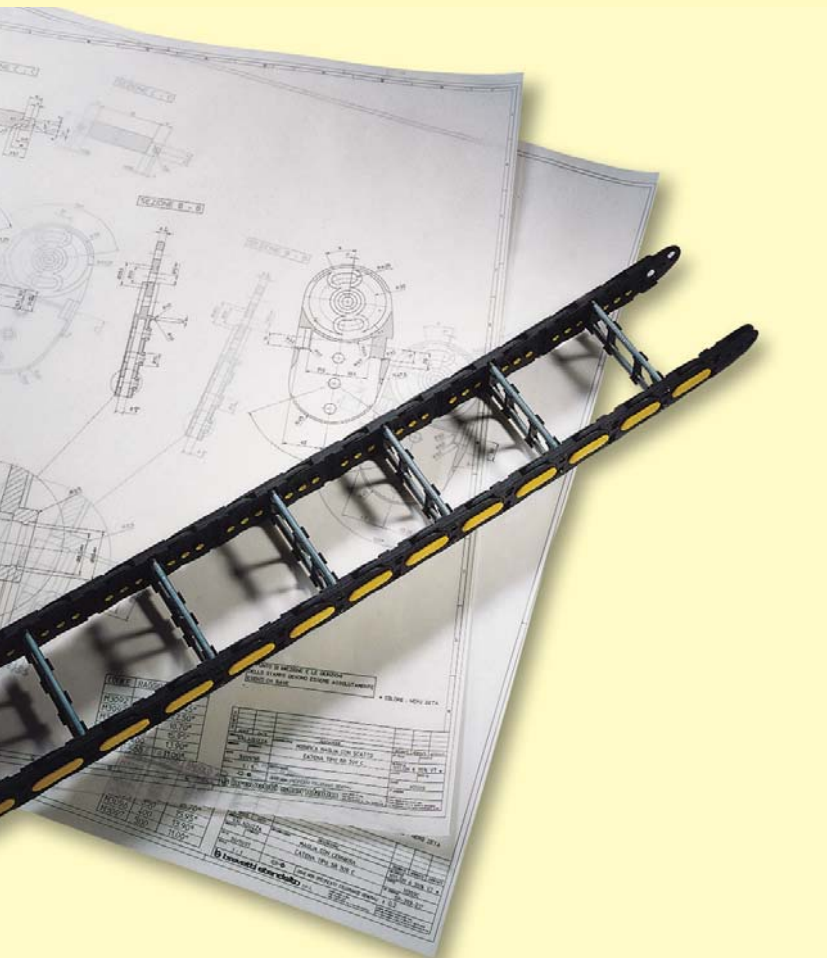

Determining the length of the travelling distance LS.

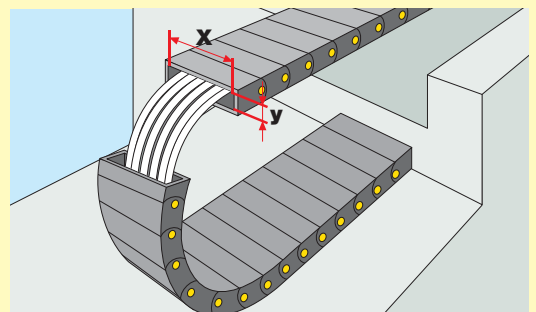

The dimensions of the cable chain in relationship to the dimensions of cables/hoses.

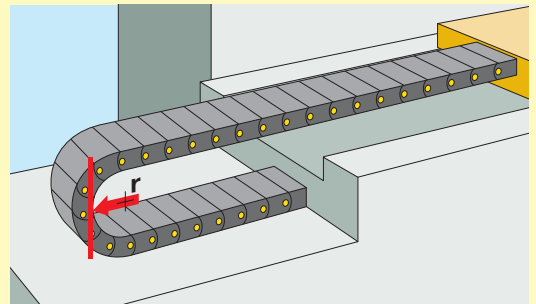

Determining the radius of curvature of the cable chain in relationship to the flexibility characteristics of cables/hoses.

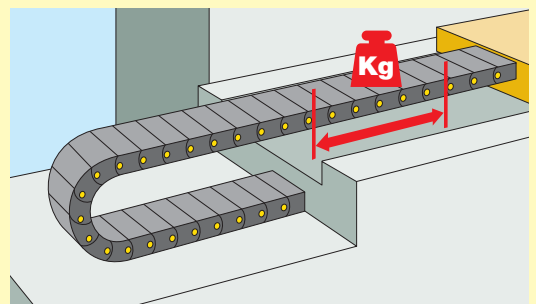

Verifying the self-supporting capacity of the cable chain in relationship to the weight per metre of cables/hoses.

# Placement of Cables/Hoses in the Cable Chains

To guarantee that cable chain functions properly and to avoid any damage to the cables/hoses within, certain criteria concerning the placement must be followed:

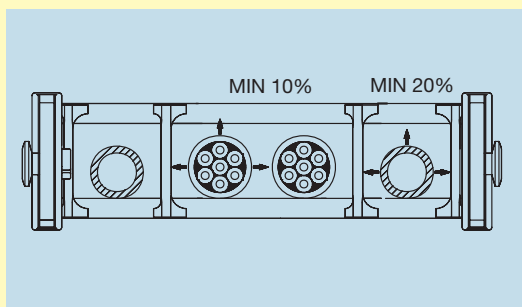

For electric cables a clearance of at least 10% between the placement of the cable and its diameter has to be guaranteed; for hydraulic hoses the clearance should be at least 20%.

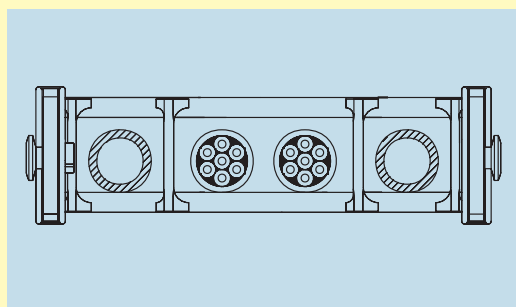

Avoid placing cables/hoses that have different sheath finishes so that friction can be eliminated. (e.g. hydraulic cables and hoses).

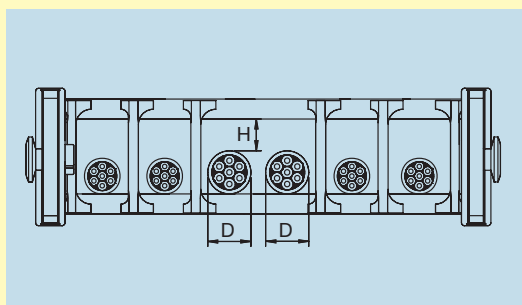

In the application of several cables/hoses it is preferable to avoid them rubbing each other by placing them singularly in the appropriate space and separating them from each other by the separators. If this is not possible, verify that the internal space does not allow the rubbing of the cables/hoses. ( $H < D$ ).

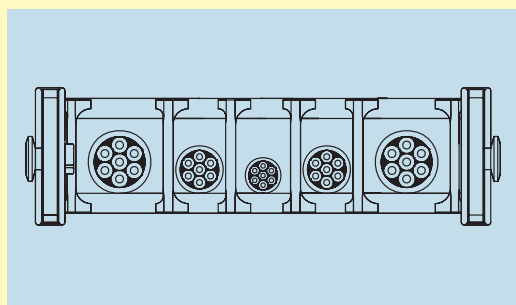

Place cables/hoses in a symmetrical way according to their dimensions and weight placing the largest and heaviest externally and the smaller and lighter internally.

For further information on how to install cables/hoses see page 198.

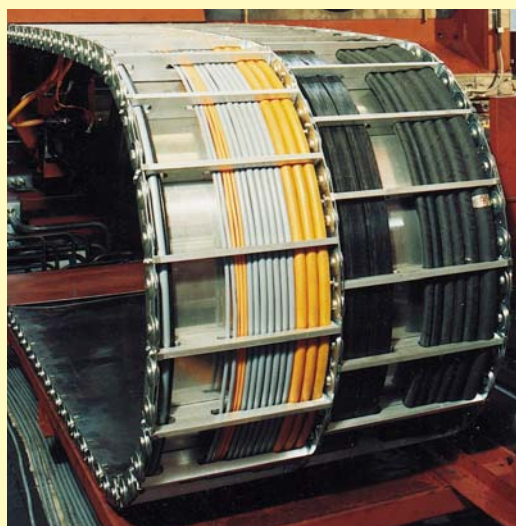

A BS3000 chain in steel with three bands and separations between electric cables and hydraulic hoses..

# Mounting Variations

## Chains Placed Horizontally

Brevetti Stendalto chains, thanks to a large range of models and versions, satisfy many requirements in variety and combination of motions. On this page the various combinations of mounting are listed.

For further information about realising a personalised project please contact our technical department. They are at your disposal to resolve any specific problems you may have and can design according to your particular request.

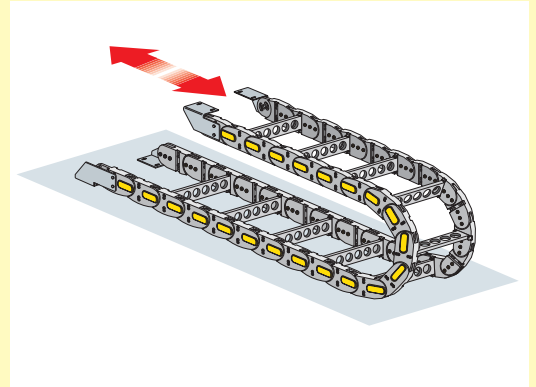

*Horizontal with mobile point above.*

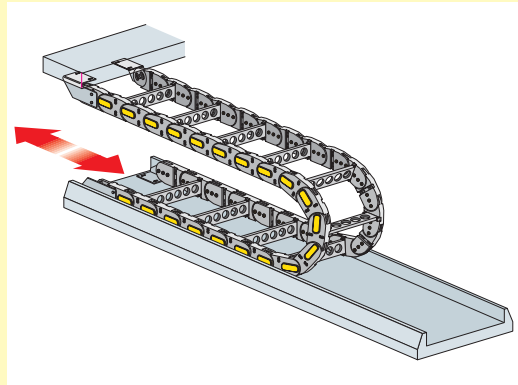

*Horizontal with mobile point below (to the car).*

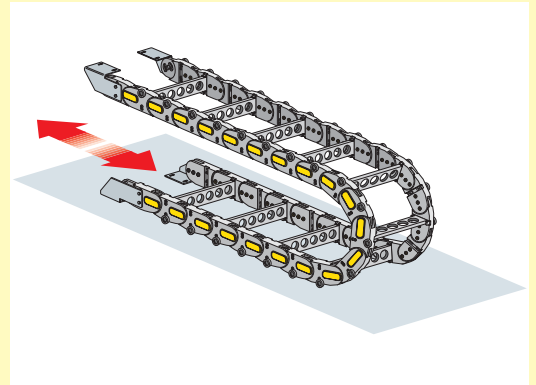

*Horizontal with mobile point below.*

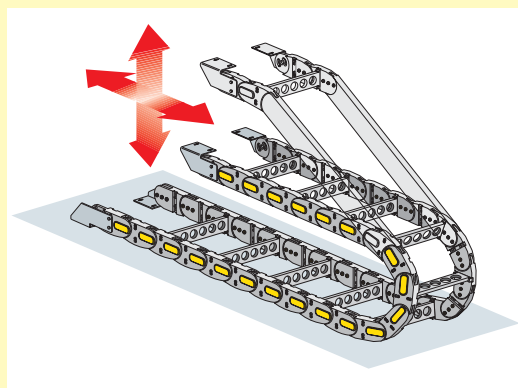

*Combination of both vertical and horizontal movement.*

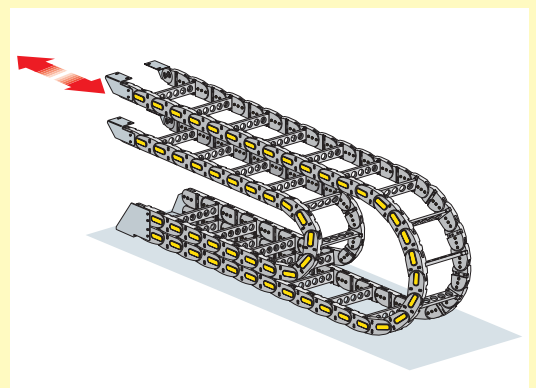

*Superimposed chains.*

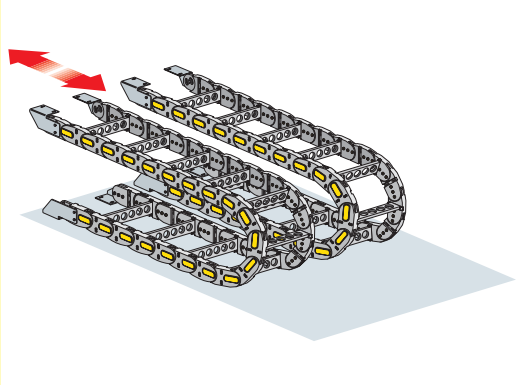

Chains positioned in parallel.

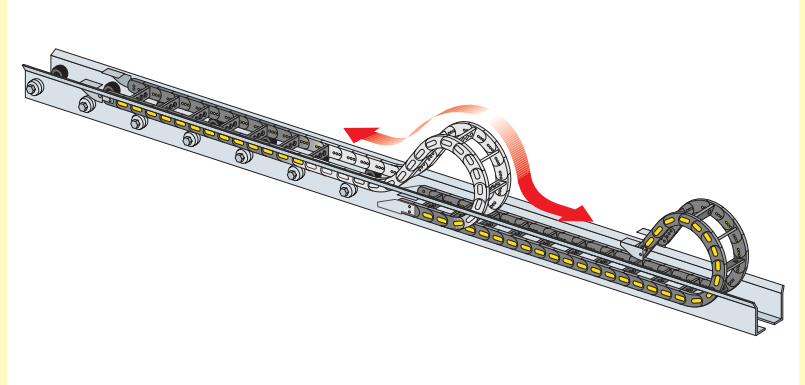

Long horizontal - 1 chain  
(see page 22).

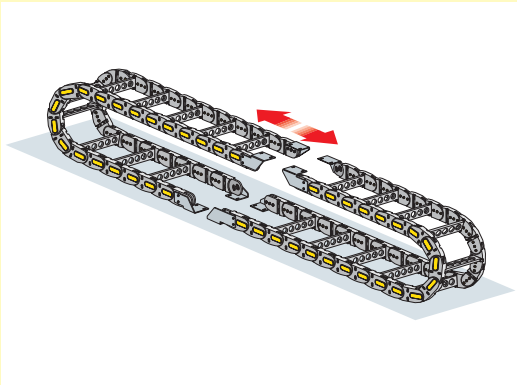

Chain making a ring configuration.

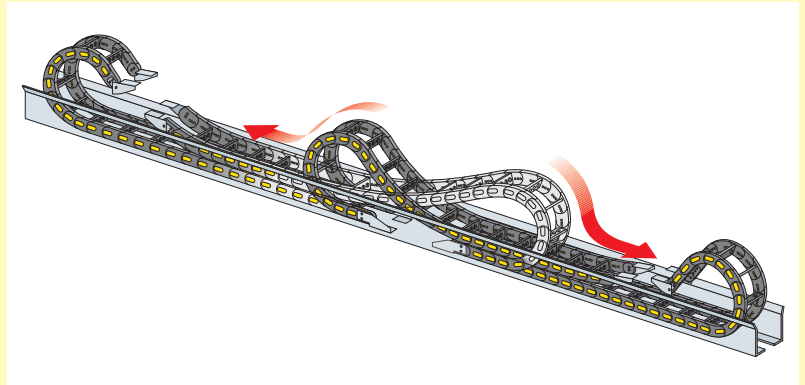

Long horizontal - 2 chains  
(see page 22).

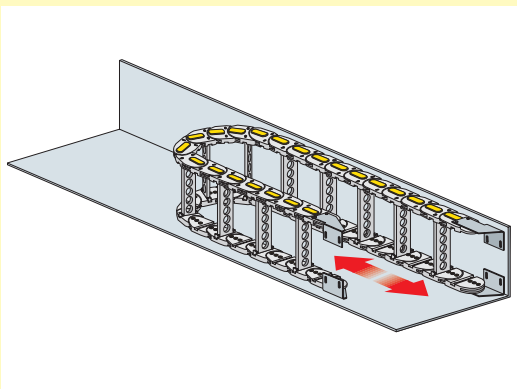

Horizontal with chain mounted on its side  
(see page 21).

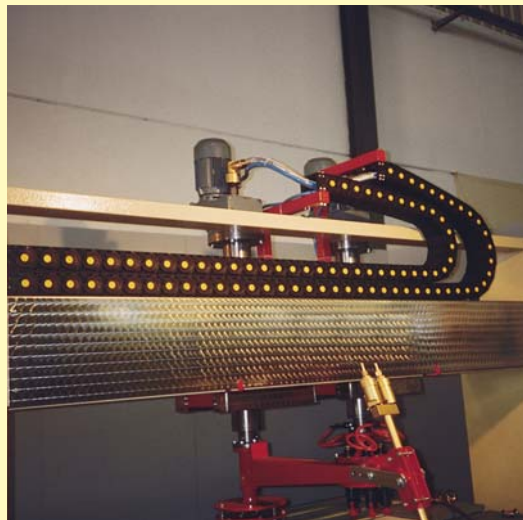

Model SR700  
chains in nylon  
superimposed on a machine  
which works with marble.

# Mounting Variations

## Chains Placed Vertically

Brevetti Stendalto chains also provide answers to problems concerning vertical motion. Thanks to their particular design Brevetti Stendalto cable chains can also be used in applications with extremely long travel distances.

2

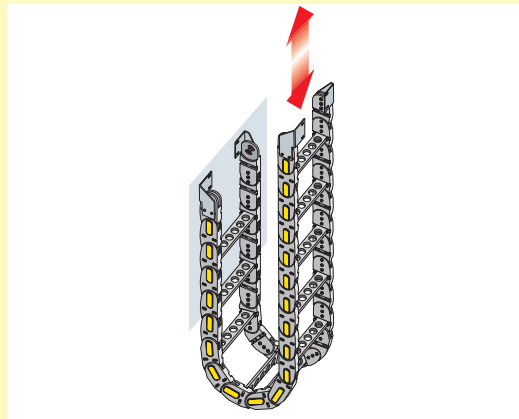

Vertical with curve below  
(see page 20).

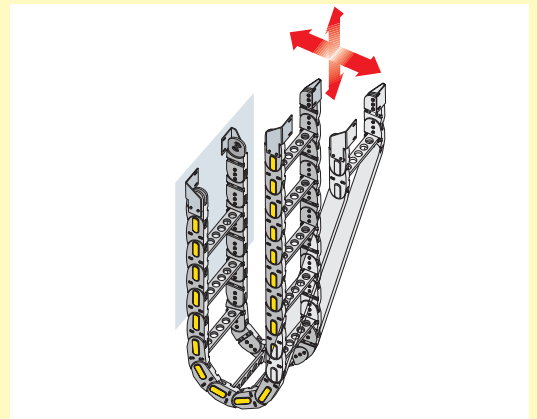

Combination of both vertical and horizontal movement.

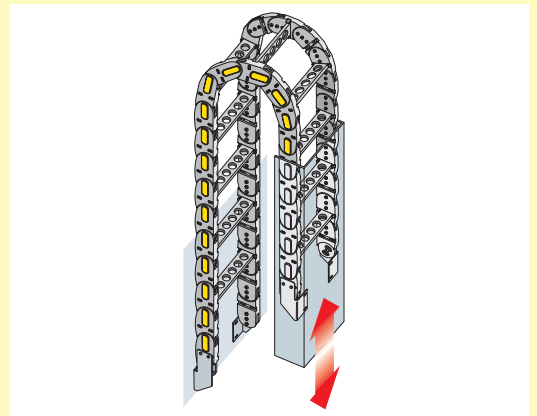

Vertical with curve above  
(see page 20).



SR355 vertical with curve below nylon chain on machine tool.



### Chains with Circular Motion

The problems regarding circular motion are easily resolved with the chains from the ROBOT series, an exclusive Brevetti Stendalto product. It is also possible to use the chains in counter-rotation configuration by mounting them on their side.

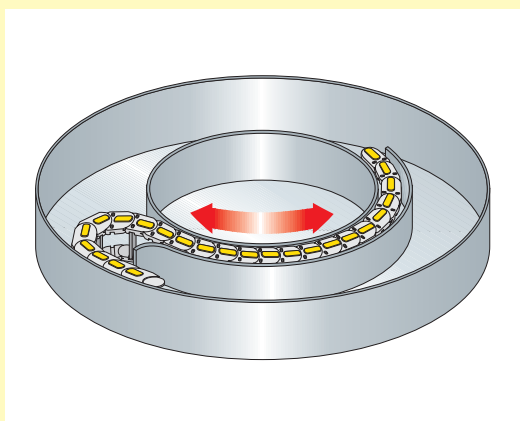

Chain for circular movement - 1 chain  
(see page 26).

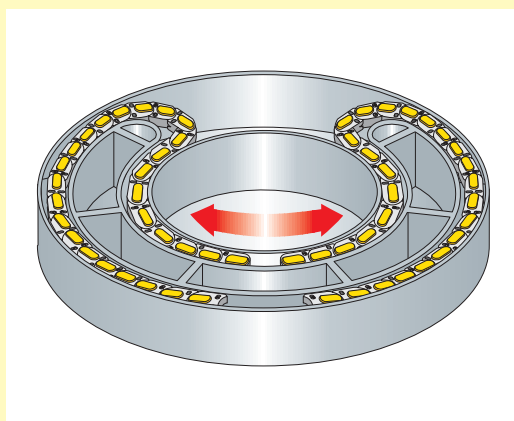

Chain for circular movement - 2 chains  
(see page 26).

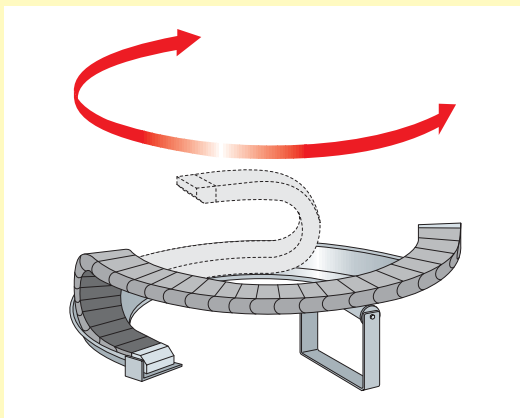

ROBOT type chain for circular motion.  
(see page 28).



Robot for welding with chains in nylon.

# Self-Supporting Capacity

A fundamental element in cable chains is the pre-set (Fig. A).

This determines the self-supporting capacity, a characteristic which allows the cable chain to support not only its own weight, but also the weight of the cables/hoses placed in it and to keep its parallel or slightly curved upward position (Fig. B).

The diagram of self-supporting capacity (Fig. C), indicates the weight relation of cables/hoses per linear meter to the lengths of self-supporting chain travel. The red-area indicates the difference between min/max chain widths, while the widest version has the lowest self-support capacity.

With the application of cable chains with  $\frac{LS}{2}$  and weights not included in the area of the diagram of self-supporting capacity, it's necessary to use the appropriate support rollers (see page 30), in order to confirm chain reliability in exceptional applications.

Brevetti Stendalto chains, thanks to their specific construction, reach remarkably high values of self-supporting capacity and acceleration with long periods of motion, reaching millions of cycles. For particular applications (e.g. vertical travel), the chains can be provided without pre-set.

2

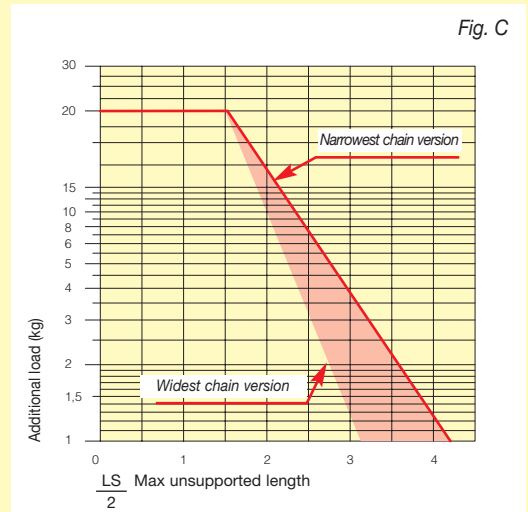
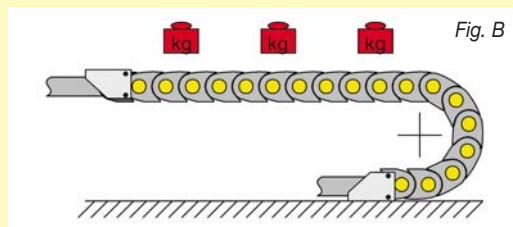
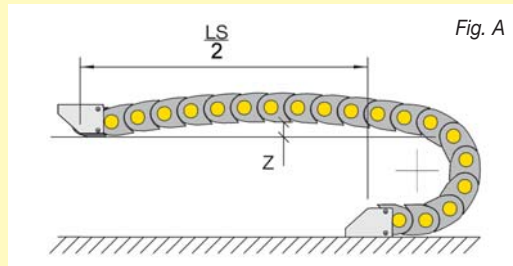

Nylon chain, type SR310, in a self-supporting state.

# Determining the Chain length

## Fixed point at the centre of total travel.

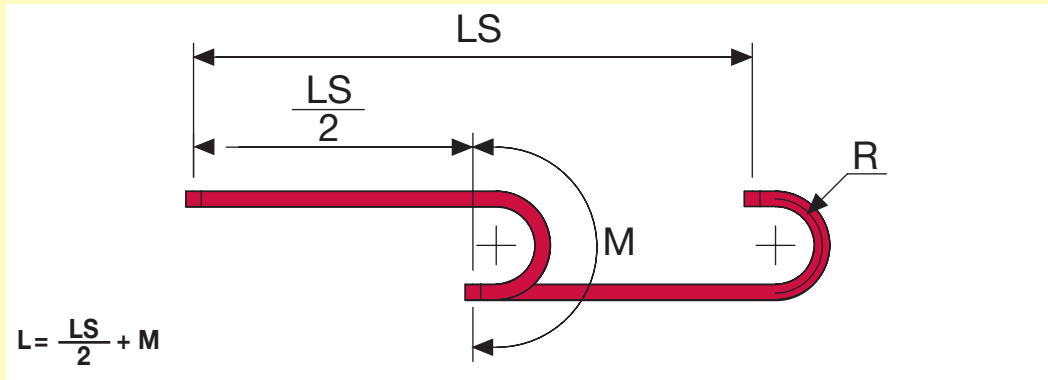

The chain length (**L**) is calculated by summarising the half stroke  $\frac{LS}{2}$  to the nominal value (**M**) of the bending radius.

The value is then rounded up the multiply of the chain's pitch for nylon cable chains and to an odd multiply for steel chains.

## Fixed point not positioned at the centre of total travel.

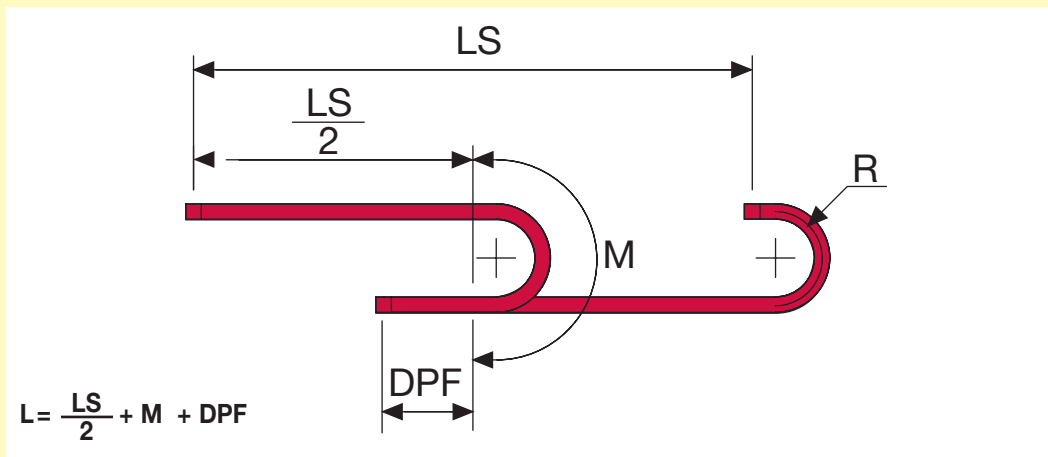

The chain length (**L**) is calculated by summarising the half stroke  $\frac{LS}{2}$  to the nominal value (**M**) of the bending radius and the distance (**DPF**) from fixed point to centre of total stroke.

The value is then rounded up the multiply of the chain's pitch for nylon cable chains and to an odd multiply for steel chains.

Where:

$L$  = Length of chain

$\frac{LS}{2}$  = Half travel distance

$M$  = Length of curve  $(\pi \times R) + (2 \times P)$

$DPF$  = Distance from fixed point to centre of total stroke

$P$  = Pitch

# Going Further

## Vertical Applications

The problems related to vertical applications are solved by using Brevetti Stendalto cable chains. It is however necessary to respect the following:

The use of standard cable chains for vertical applications could result in difficulties due to the pre-set. we therefore recommend to specify: *“without pre-set for vertical applications”* when ordering. By doing this the cable chain will be delivered to you without pre-set.

2

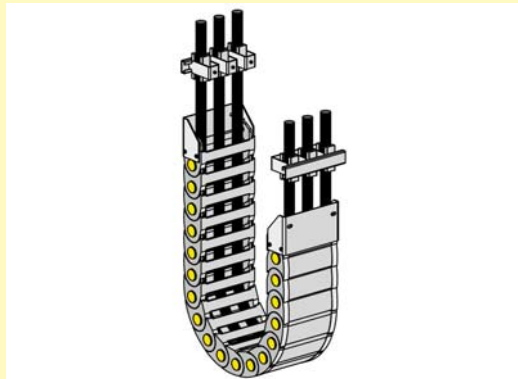

*The placement of the cable/hoses is very important to ensure the application works properly. Cables/hoses have to be fixed at both ends using the appropriate accessories so as not to make their weight disturb the cable chain. In this type of application the cable chain should only guide the cables/hoses during their movement.*

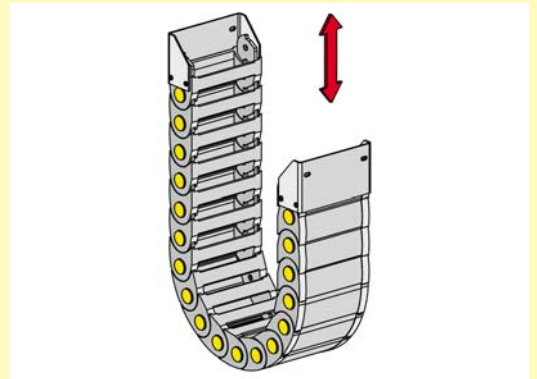

*If the application only concerns one vertical movement the cable chain does not need any particular support.*

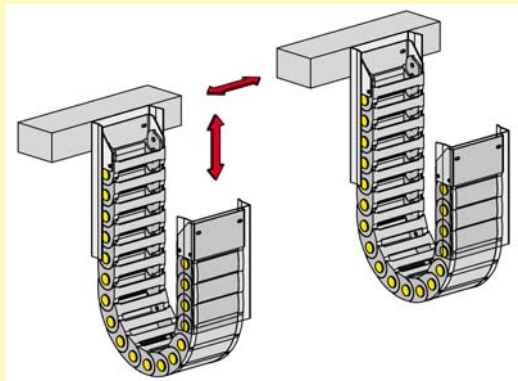

*If the cable chain also moves across and/or longitudinally, certain measures have to be taken laterally. For special applications, frames with completely closed guiding systems are available.*

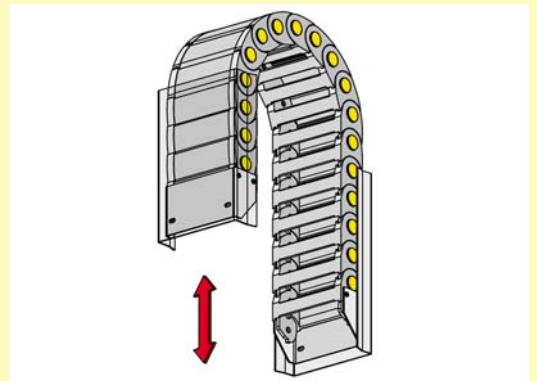

*When applying the cable chain in this way some support is needed to avoid the chain to unbalance itself outwardly. Generally the cable chain must be supported both on the fixed and mobile points.*



# Going Further

## Horizontal Applications on Their Sides

Brevetti Stendalto cable chains can be mounted on their sides.

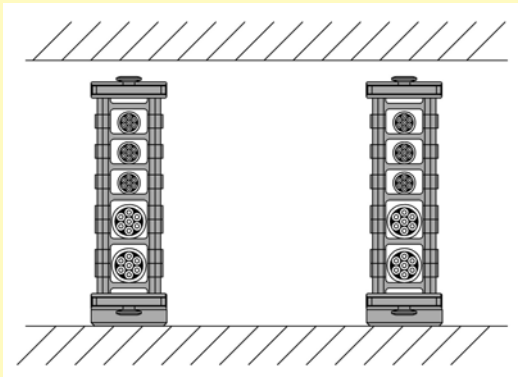

This kind of mounting becomes necessary when there is a limited space upwards and mounting the chain normally would take up too much space.

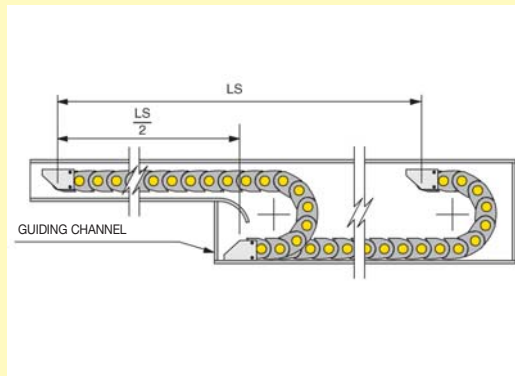

For particularly long applications a guiding channel can be designed.

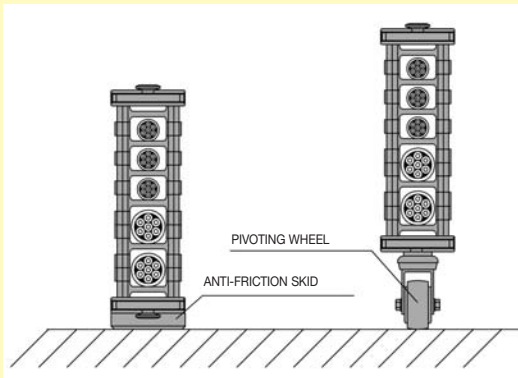

To make the movement easier and to reduce any friction on the cable chain, special changeable anti-friction skids or pivoting wheels have been designed.

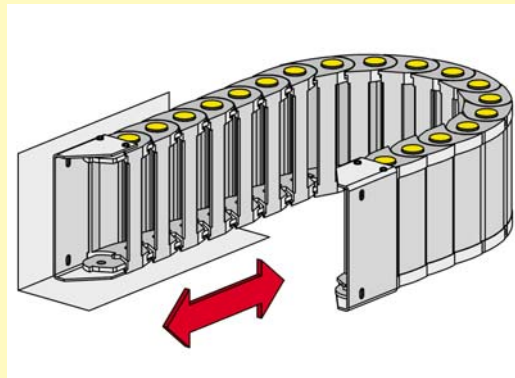

If there is no possibility for a plane to support the cable chain during its movement, Brevetti Stendalto chains can be applied without support taking into consideration the following factors:

- total travel distance LS
- added weight
- velocity and acceleration
- frequency of usage

For this kind of application, it is recommended to discuss with our technical office.

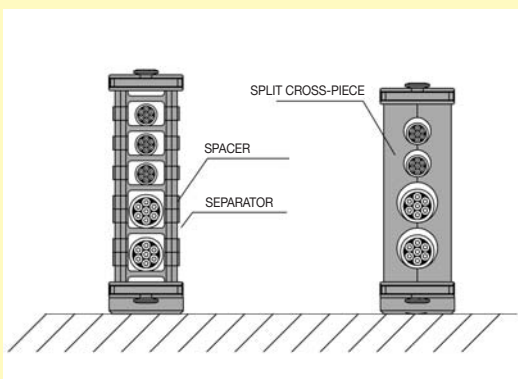

Particular attention should be drawn to determine the section of the cable chain, in fact, the mounting on its side of the chain means that cables/hoses have a tendency of bunching towards the ground and being squashed.

To avoid this, there are special spacers which are positioned between the separators or otherwise special split aluminium or PVC cross pieces to be applied.

# Going Further



## Long Horizontal Travel Distance

Cable chains are used more frequently on long travel distances as a valid alternative to the traditional systems of conductor bars or to festoon systems, and offer the following advantages:

- The possibility of the combined transportation of hydraulic cables/tubes.
- The possibility of use also in critical environments (humidity, textile dust, negative chemical and atmospheric components etc.).
- High velocities and values of acceleration.
- Notably shorter installation times.
- Drastic reduction in the time taken for maintenance.

Sliding series is the integrated sliding skid which permit the chains to slide on themselves reducing the friction due to the special polymers used.

The dimensions of the skid allow the chain to keep itself stable in applications with high velocities.

On request it's possible to produce cable chains with special polyamides for applying in particularly aggressive environments.

The triple pins guarantee more reliability and strength even in applications with the added weight being very high. The chains in the Sliding series have been tested using torsion, wear and tear tests passing the tensile yield stress with extremely good results, above high normal values (e.g. SR318 21000 N).

The special aspect of the cable chains in the

*In these applications, the chain without self-supporting capacity, slides in its own guiding channels. For the first half of the travel distance the chain slides on itself, whilst in the second half it is supported by its own rollers or plates for sliding.*

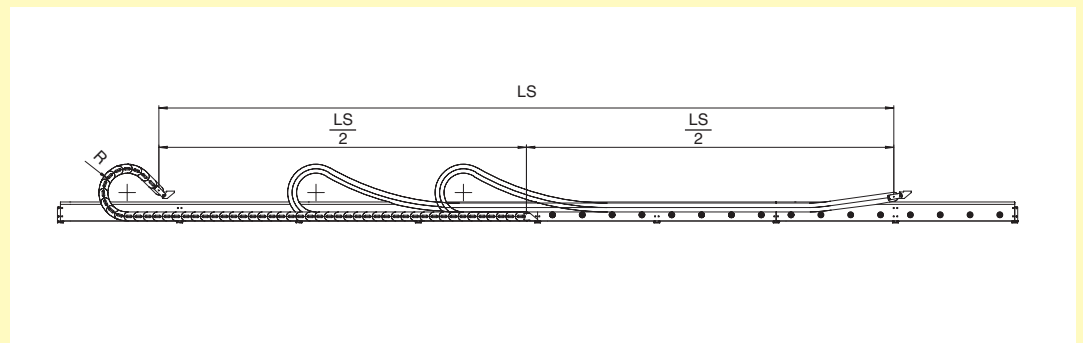

*In double chain applications, the chains slide on themselves in both directions.*

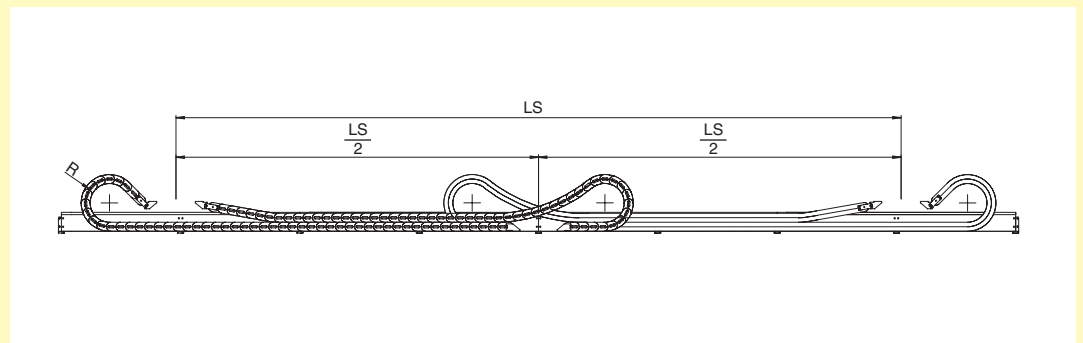

*A particular of the skid in the sliding of the chains in the Sliding series.*

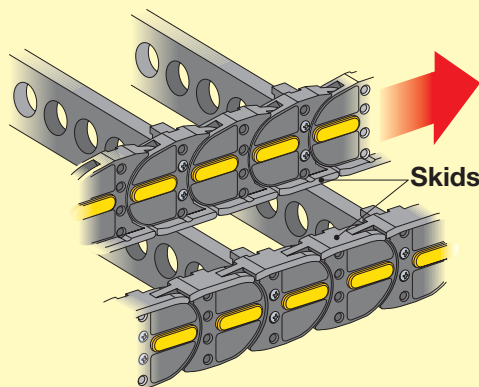



SR318 type chain.



SR318 type chain.

# Going Further

## Guide Channels for Sliding

For good results when using cable chain in an application with a long travelling distance it is necessary to respect the following instructions when installing the guide channel for sliding:

2



Guide channel for chains of the Sliding series.

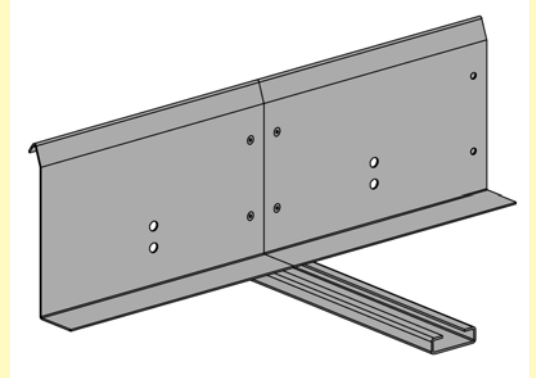

Verify that the sides are aligned properly to avoid any internal edges in the guide channel which could disturb the cable chain's route.

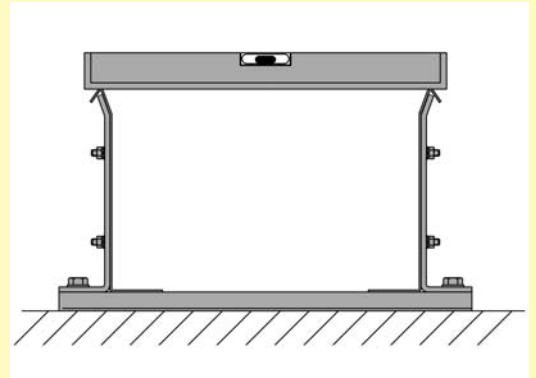

Verify that the plane on which the guide channel for sliding is mounted is perfectly aligned and smooth.

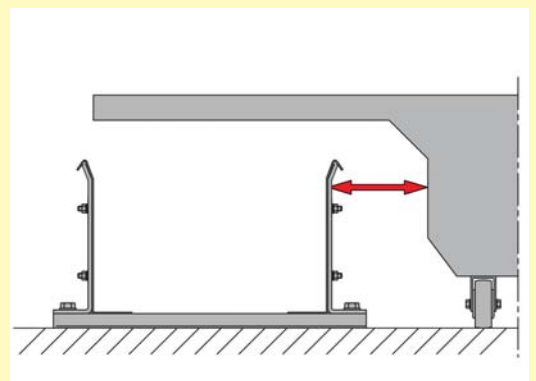

Verify that the distance between the guide channel for sliding and the towing arm is the same for the whole travelling distance.



## How to Install the Cable Chains in the Guide Channel

For a perfect installation of the cable chain in the guide channel you should take the following steps::

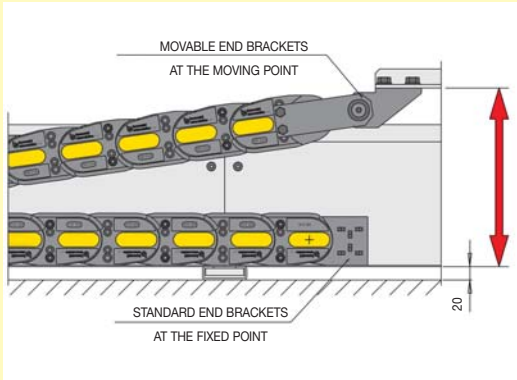

Install the cable chain with the standard end brackets at the fixed point and with the movable end brackets at the moving point respecting the height listed in the catalogue.

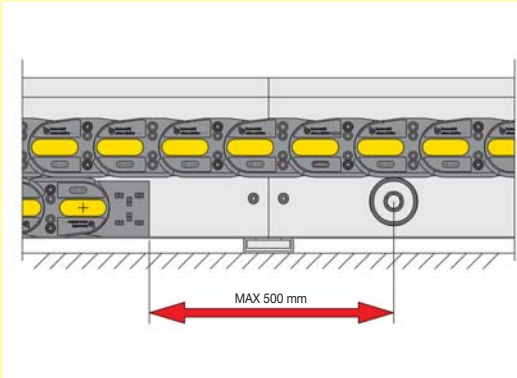

Reduce as much as possible the distance between the fixed point of the cable chain and the starting point of the rollers or sliding plane.

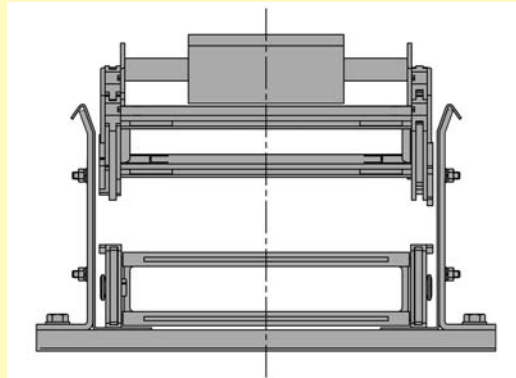

Install the mobile point of the cable chain aligning it exactly to the longitudinal travel distance in such a way so that during its movement it does not touch the internal part of the guide channel (Fig. A).

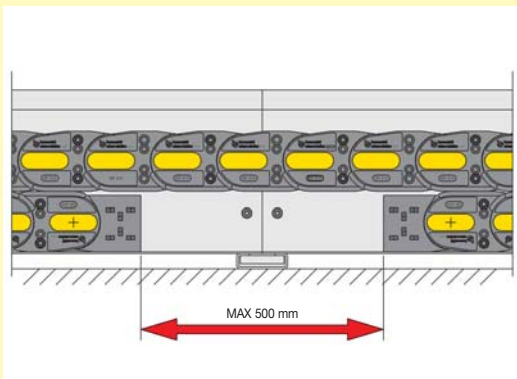

In the case of a double chain application ensure that the distance between the two fixed points doesn't exceed 500mm.

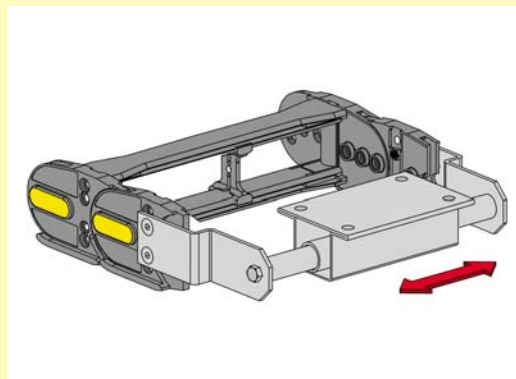

To facilitate this operation Brevetti Stendalto has developed and created a special movable end bracket which guarantees a perfect alignment between the chain and the towing arm (Fig. B).

# Going Further

2

## Rotating Horizontally

For certain applications it necessary that the cable chains perform an opposite movement from that determined by the radius of the curvature (counter-radius chains). All Brevetti Stendalto chains, except those from the

PROTECTION series, can be supplied with this counter-radius. Generally the chains with counter-radius are used to resolve the problems relative to rotations where, in this case, it would not be possible to use cable chains from the ROBOT series.

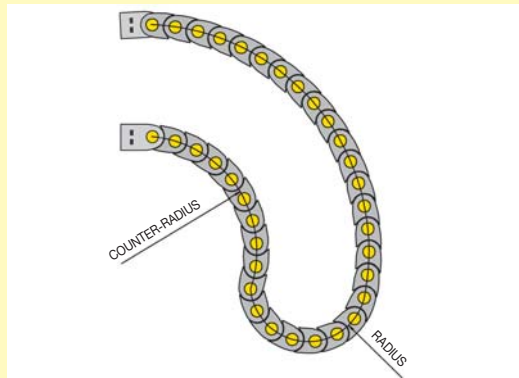

With the use of counter-radius chains it is possible to create rotations both on small and large equipment (e.g. parabolic antennas, rotating tables, cranes, telescopes).

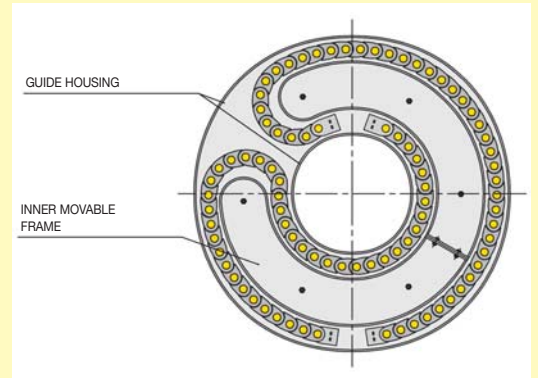

For applications with rotations over 180° it is necessary to use two cable chains. For a correct usage they should be guided both internally and externally. A special inner movable frame, mounted on anti-friction skids or pivoting wheels in combination to the guide housing guarantees the rotation.

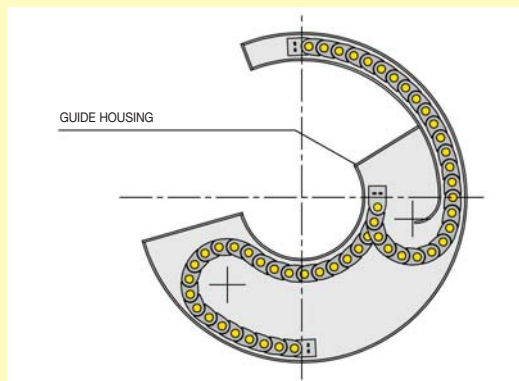

For applications with rotations up to 180° it is possible to use only one cable chain. For a correct usage it should be installed with a guide housing.

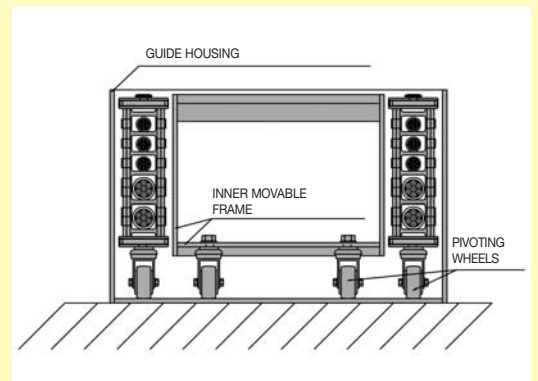
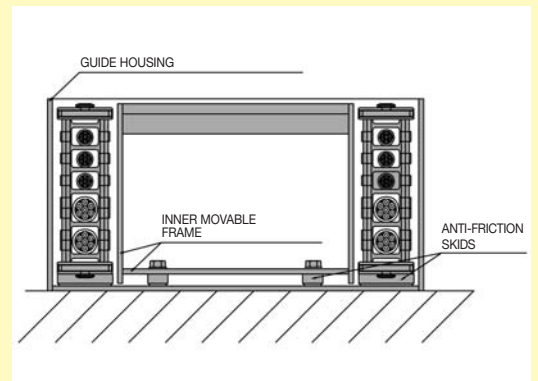

To facilitate the sliding and reduce the friction of the cable chain, special changeable skids or pivoting wheels are taken into account. With this kind of application it is also possible to rotate vertically. Seen the particular aspects of these applications we advise you to contact and consult our technical office.

## Application of Horizontally Rotating Chains

Chains can reach a maximum rotation of 540°. For a correct usage they should be guided both internally and externally.



*Application with 2 superimposed chains.  
Rotation 180°*



*Application with 2 chains.  
Rotation 370°*



## Rotation with ROBOT Type Chains

In its continuous technological evolution, Brevetti Stendalto has revolutionised since 1989 the concept of circular chains introducing the chains from the "ROBOT" series that, due to the particular construction of the links, permit them to rotate up to 540°. During the long course of technical experience, applications with rotations up to 600° per

second have been developed. The chains from the "ROBOT" series, like all Brevetti Stendalto chains, can be modified for work in special applications.

When the use of one cable chain is not sufficient to contain all the cables/hoses it's possible to use several chains in the same application to increase the space to hold them.

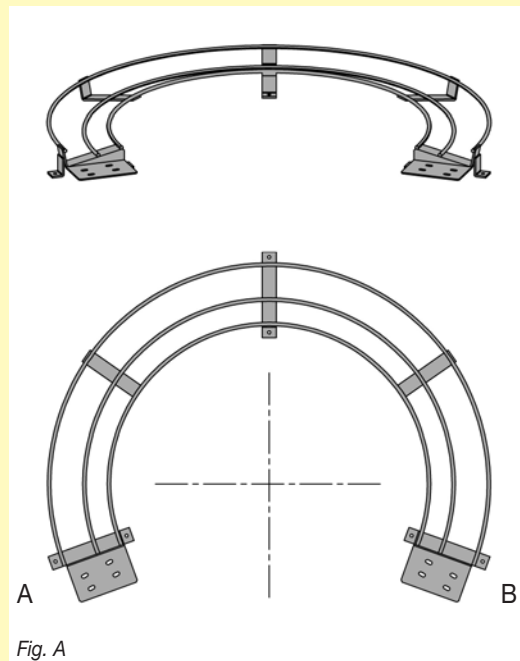

Fig. A

The stability of the chains permits rotations at higher velocities without the need for guiding supports. Only the base on which the cable leans has to have a configuration inclined to make its own travel distance easier. Appropriate support guides are available if it is not possible to take them directly from the machine.

## Supporting Hook

This must be selected according to the method of chain fixation.

-Left type with left fixed point chain (A)

-Right type with right fixed point chain (B)

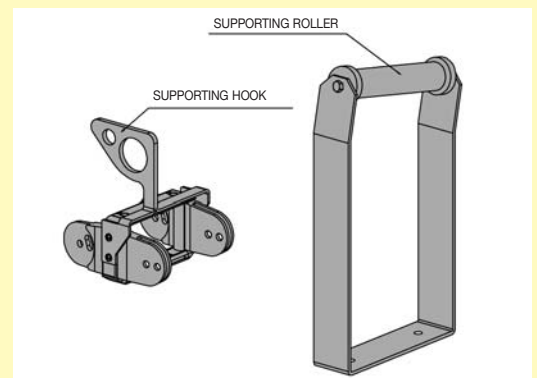

The chains from the "ROBOT" series are self-supporting and they do not need any support up to 200°. For applications with rotations exceeding that value it is necessary to use its own appropriate accessories. To reduce the problems of taking up too much space which generally is the case with the supports, especially on robots, Brevetti Stendalto has developed a series of supports which are capable of solving the problem.

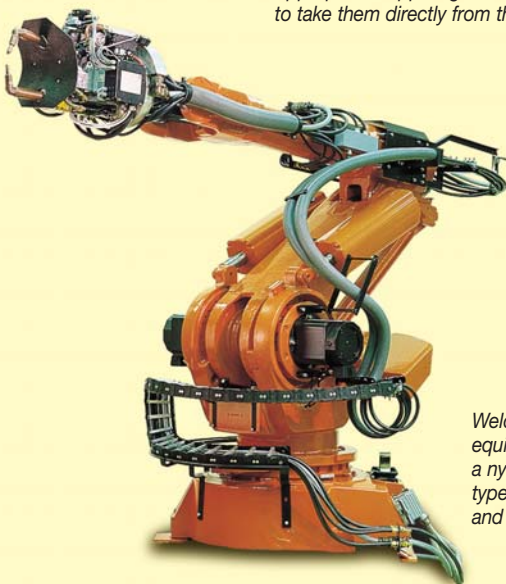

Welding robot equipped with a nylon cable chain type SR510 and guide support.

## Applications with Robot Series Chains

Using support rollers or support hooks, chains can reach a maximum rotation of 540°.

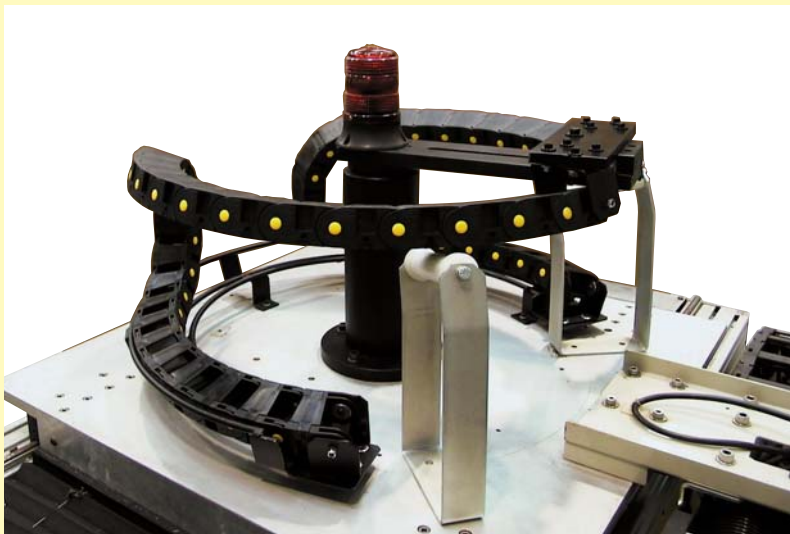

Support rollers view.



Support hooks view.

# Going Further

## Support Roller Units

For applications of cable chains with  $\frac{LS}{2}$  and weights not included in the area of the diagram of self-supporting capacity it is

necessary to use the appropriate support rollers.

To decide on the number of support rollers needed, note the following:

### One Support Roller when:

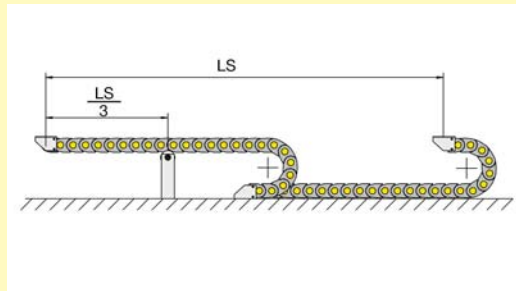

The length  $\frac{LS}{3}$  is included in the values of the diagram showing self-supporting capacity.

### Two Support Rollers when:

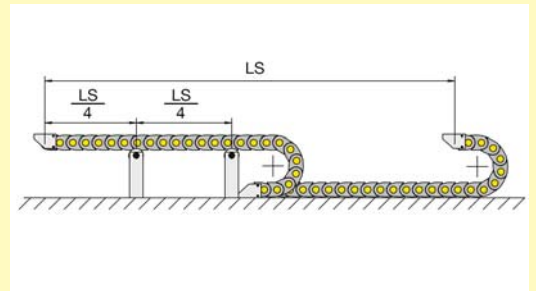

The length  $\frac{LS}{4}$  is included in the values of the diagram showing self-supporting capacity.

## Support Roller for Nylon Chains

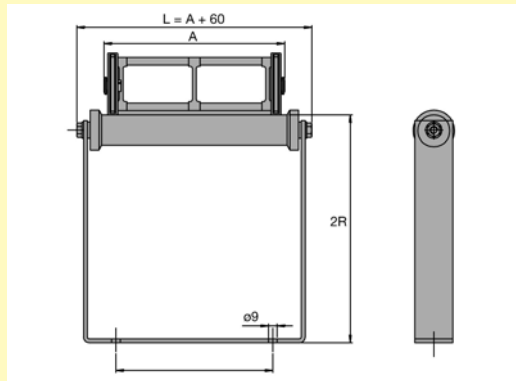

## Support Roller for Steel Chains

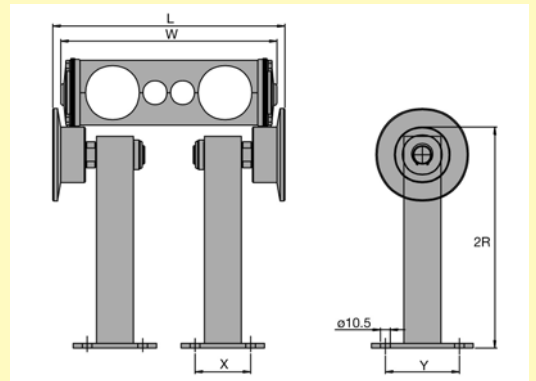

Chain Type	X	Y	L
BS2000	70	100	W+22
BS3000	70	100	W+22
BS3500	70	100	W+26
BS4000	70	100	W+26
BS4500	130	180	W+26



## Ways of Mounting End Brackets

The end brackets make the installation of the chains possible. They are available both in nylon and in steel. The end brackets in nylon, due to their particular construction with holes for mounting on three sides, allow the chain to be

installed in the four positions seen below. For the end bracket in steel instead it is necessary to specify the position of mounting. If this is not specified it will be supplied in Pos.1. Our technical office is at your disposal to solve any installation query.

Pos. 1

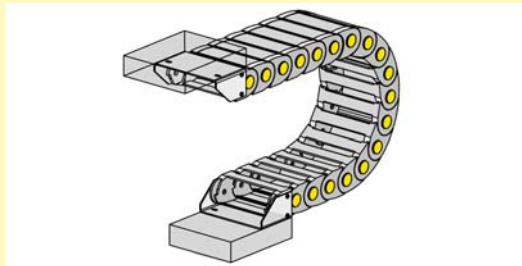

Pos. 2

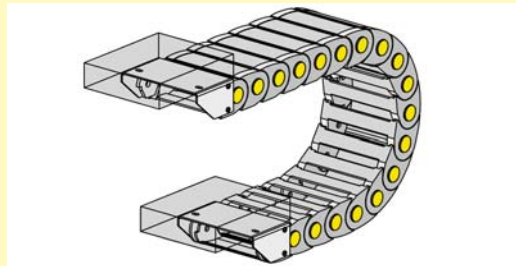

Pos. 3

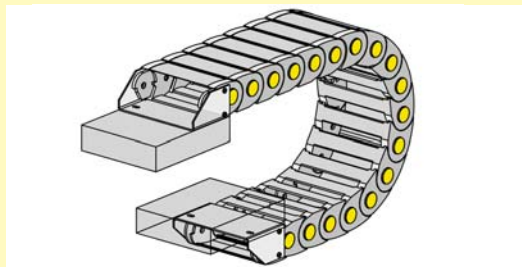

Pos. 4

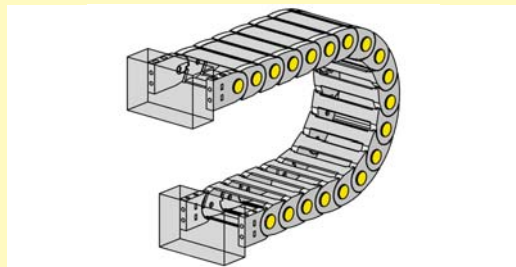

Chain Type	Nylon End Brackets				Steel End Brackets			
	Pos.1	Pos. 2	Pos. 3	Pos. 4	Pos. 1	Pos. 2	Pos. 3	Pos. 4
SR200...	S	-	-	-	-	-	-	-
SR250...	S	O	O	-	-	-	-	-
SR30090-SR30091	-	-	-	-	S	R	R	O
SR325LI/LE	S	S	S	-	S	S	S	O
SR325A...	S	S	S	-	S	R	R	O
SR325...	-	-	-	-	S	R	R	O
SR339...	-	-	-	-	S	S	S	O
SR300A...	S	-	-	-	S	O	O	O
SR300...	-	-	-	-	S	R	R	O
SR305A...	S	S	S	S	S	O	O	O
SR305...	S	S	S	S	S	R	R	O
SR355A...	S	S	S	S	S	O	O	O
SR355...	S	S	S	S	S	R	R	O
SR400...	S	S	S	-	S	O	O	O
SR435...	S	S	S	S	S	R	R	R
SR445...	S	S	S	S	S	R	R	R
SR660A...	S	S	S	S	R	R	R	O
SR770A...	S	S	S	S	R	R	R	O
SR475...	-	-	-	-	S	R	R	O
SR306...	S	S	S	S	S	R	R	O
SR307...	S	S	S	S	S	R	R	O
SR308...	S	S	S	S	S	R	R	O
SR309...	S	S	S	S	S	R	R	O
SR310T...	-	-	-	-	S	R	R	O
SR660...	S	S	S	S	R	R	R	O
SR770...	S	S	S	S	R	R	R	O
SR309C...	S	S	S	S	S	R	R	O
BS2000...	-	-	-	-	S	S	S	S
BS3000...	-	-	-	-	S	S	S	S
BS3500...	-	-	-	-	S	S	S	S
BS3500C...	-	-	-	-	S	R	R	O
BS4000...	-	-	-	-	S	R	R	O
BS4500...	-	-	-	-	S	R	R	O

S= Standard  
R= On request  
O= Special production  
- = Not available

# Going Further

## Guide Channel

For a correct functioning of the cable chain it is necessary that during it's movement it lies on a flat surface. If these conditions do not exist a guide channel is necessary.

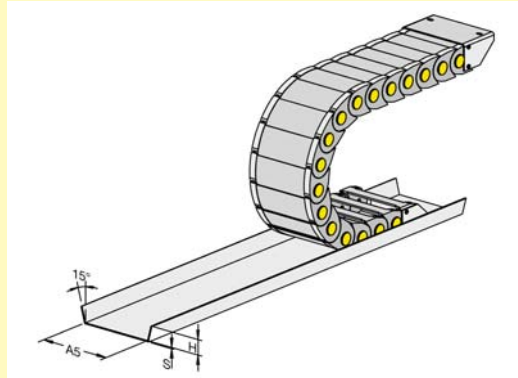

2

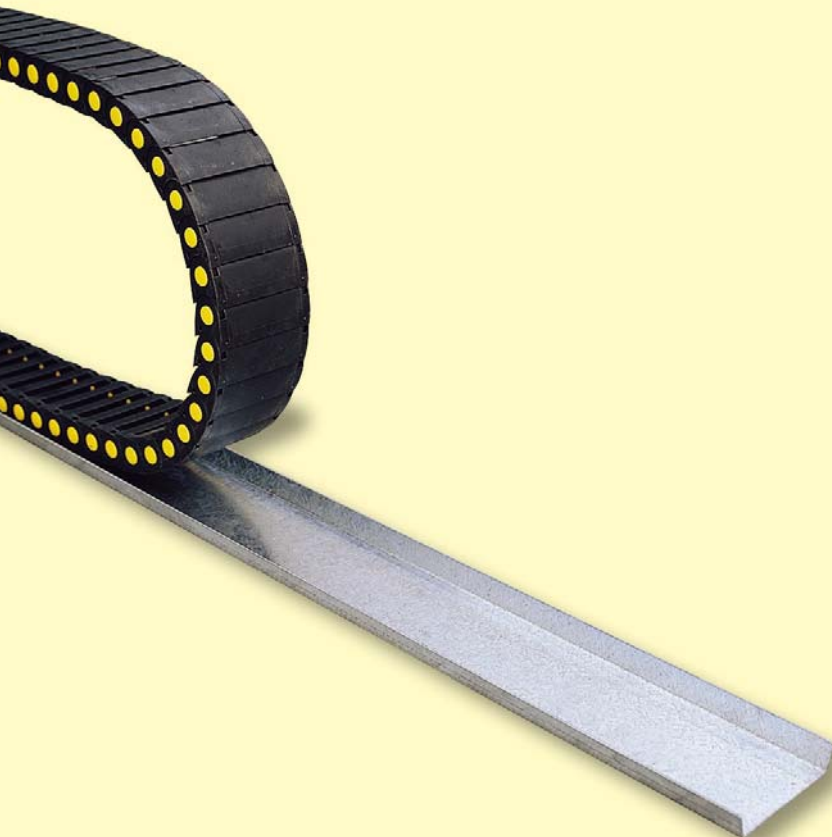

Chain type	A5 mm	H mm	S mm
SR200...	A+2	10	1,5
SR250...	A+2	10	1,5
SR30090-SR30091	A+2	15	1,5
SR325LI/LE...	A+2	25	1,5
SR325A...	A+2	25	1,5
SR339...	A+2	30	1,5
SR325...	A+2	25	1,5
SR300A...	A+2	15	1,5
SR300...	A+2	15	1,5
SR305A...	A+2	20	1,5
SR305...	A+2	20	1,5
SR355A...	A+2	25	1,5
SR355...	A+2	25	1,5
SR400...	A+2	25	1,5
SR435...	A+2	30	1,5
SR445...	A+2	30	1,5
SR660A...	A+2	30	1,5
SR770A...	A+2	30	1,5
SR475....	A+2	50	1,5
SR306...	A+2	30	1,5
SR307...	A+2	30	1,5
SR308...	A+2	40	1,5
SR309...	A+2	50	1,5
SR310T...	A+2	80	1,5
SR660...	A+2	30	1,5
SR770...	A+2	30	1,5
BS2000...	W+2	30	1,5
BS3000...	W+2	40	1,5
BS3500...	W+2	50	
BS4000...*			
BS4500...*			

\*Seen the particular aspects of these chains we advise consultation with our technical office.

The guide channel is delivered in laminar zinc in pieces of 2000 mm. It is available on request in stainless steel.

Guide channel for chain type SR355.



## Split Cross Pieces Heavy/Sliding Series

The chains from the Heavy and Sliding series are developed with two side-bands of chain connected with split cross pieces that can be

chosen between a wide number of styles to suit most various requests.

### Standard Versions:

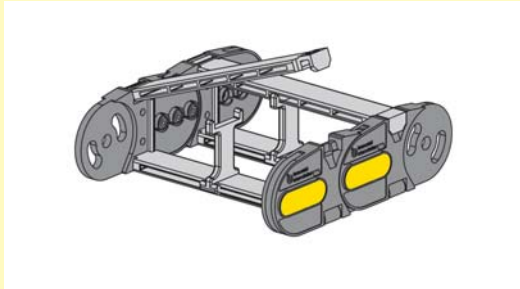

The new nylon split cross piece can open by an easy to open hinge, offering a security.

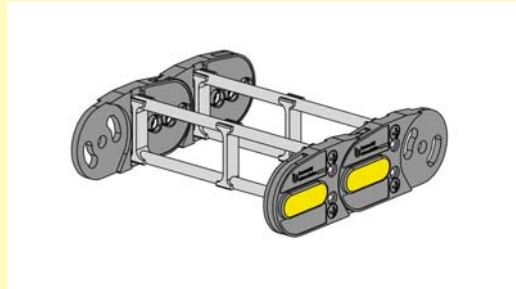

Aluminium rods screwed at the links. Maximum strength in every application. Possibilities in customising it's width. A separation of cables system.

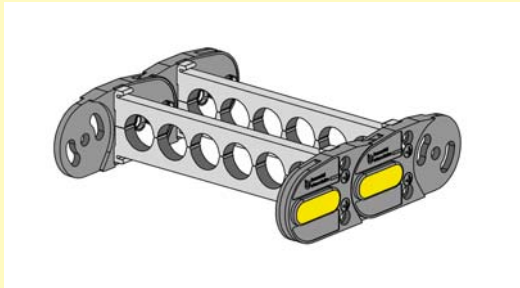

Nylon split cross pieces with holes. Many possibilities of choice between the standard models or special version on request.

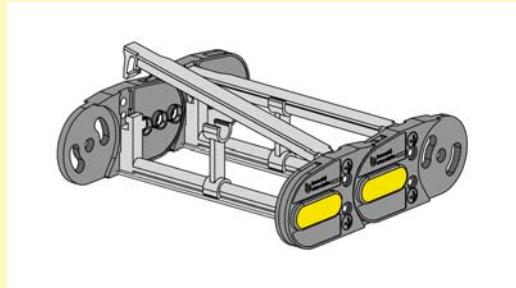

Nylon split cross pieces which open by a zip, to facilitate the operations of positioning the cables internally in the chain.

### Special Versions:

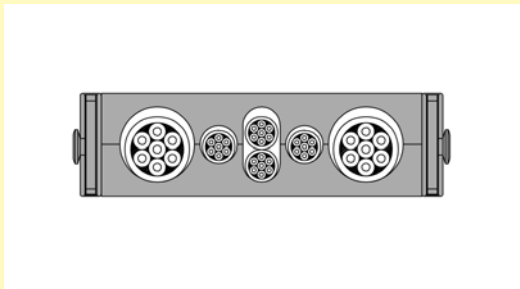

Split cross pieces made on request. The ideal solution in the case of numerous cables with limited amount of space.

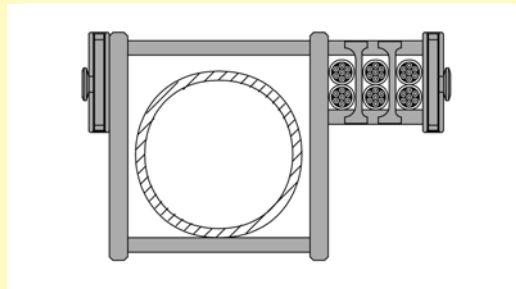

Larger split cross pieces. For the transportation of hoses of notable dimensions.

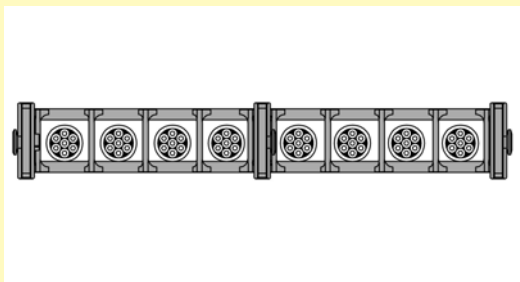

Multiple side-band chains. If it was necessary to increase the self-supporting capacity and the stability when having a large number of cables.

# Materials Used

The Brevetti Stendalto cable chains in nylon are developed with a special polyamide reinforced with glass fibre, BRYLON 6. The high resistance to tension, the low coefficient of friction together with the general characteristics of the most evolved compound thermoplastics, allow the cable chains to be used in all environments and temperatures. The main characteristics of BRYLON 6 are:

## Self-Extinguishing

Brylon 6 has the certificate UL94HB. On request the use of the polyamide V0 or V2 can be used. The resistance at eventual sparks is good.

## UV Rays

Brylon 6 is resistant to UV rays and it's therefore suitable for external applications.

## Chemical Resistance

Brylon 6 is generally resistant to oils, grease, petrol, ammonia and water (sea water). Problems could arise with the presence of acids. (See the detailed table showing resistance to various chemical agents).

## The Colouring.

The standard colouring of the Brevetti Stendalto cable chains is to have the links in black and the pins in yellow.

This combination, apart from being eye-catching represents a further security measure, the chain

## Working Temperature

Brevetti Stendalto cable chains made of polymers can be used in application with a temperature range between  $-25^{\circ}$   $+125^{\circ}$ . In case of application with "continuous" temperature lower than  $-15^{\circ}$  and higher than  $+95^{\circ}$ , the mechanical values could be reduced. In both the cases Brevetti Stendalto is able to offer solutions using special compounds; please consult us. On request it is possible to create and develop cable chains using special polyamides to be used in the following applications:

## Ex-Proof

Cable chains complying with ATEX Directive 94/9/CE. Nylon cable chains, to be used in explosion high-risk environments, can be supplied made of the special material BRYLON AD. For further information please refer to Brevetti Stendalto's Technical Office.



## Clean room-proof

To be used in clean rooms. The standard version of the cable chain SR305A009

has been tested and proved to be Class 1. For further information you may require the proper documentation to our technical department.



2



Colour options.

### Links

standard colour: black  
colours by request: yellow, red, blue, green, grey.

### Pins

standard colour: yellow  
colours by request: black, red, blue, green.

SR700 yellow nylon chain with the pins in black.

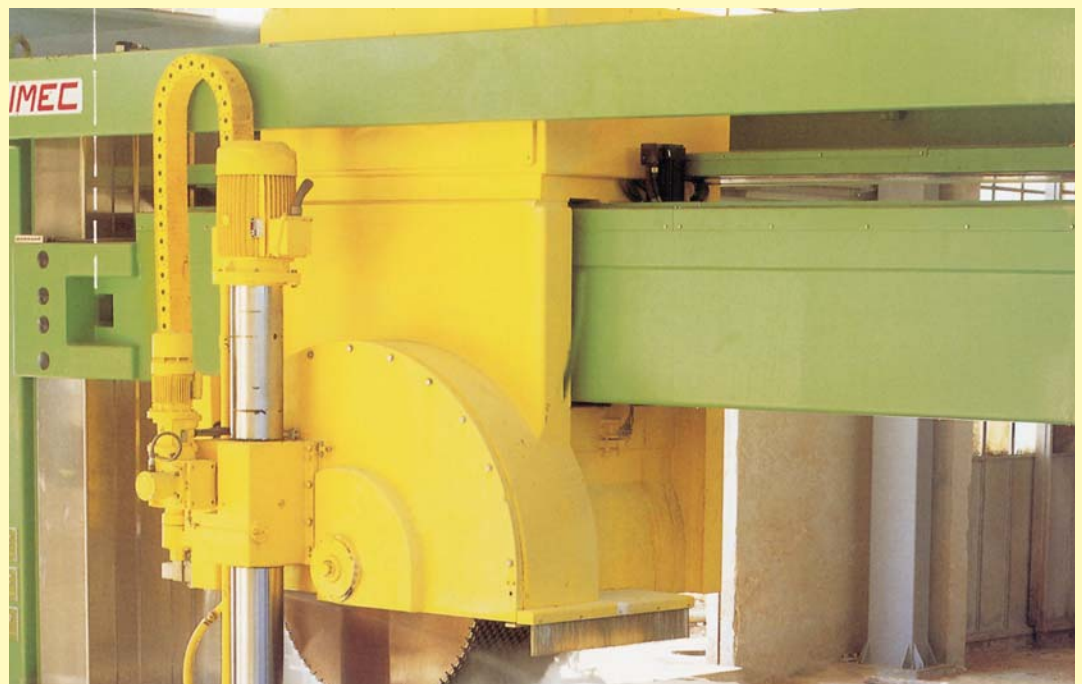

## BRYLON 6 Technical Data

Norms	Properties	Units	Typical values	
			Dry	Conditioned
<b>Thermal properties</b>				
DSC	Melting point (10°C/min.)	°C	222	
ASTM - D 696	Coefficient of linear thermal expansion	X10 <sup>-6</sup> K <sup>-1</sup>	28	
ASTM D 648	Heat distortion temperatur			
ISO 75	1.82 N/mm <sup>2</sup>	°C	210	
DIN 53461	0.45 N/mm <sup>2</sup>	°C	220	
U. L. 94	Flammability		H.B.	
IEC 695-2-1	Incandescent wire Temperature Thickness	°C mm	650 3	
<b>Flammability</b>				
ASTM-D 257	Volume resistivity	Ohm cm	10 <sup>15</sup>	10 <sup>11</sup>
ASTM-D 257	Surface resistivity	Ohm	10 <sup>13</sup>	10 <sup>11</sup>
ASTM-D 149	Dielectric strength	KV/mm	22	
ASTM-D 150	Dielectric constant (10 Hz)	—	3.8	4.5
ASTM-D 150	Dissipation factor (10Hz)	—	0.02	0.09
<b>Physical properties</b>				
ASTM-D 792	Density	g/cm <sup>3</sup>	1.38	
ASTM-D 570	Water absorption at 23°C in water for 24 hours	%	0.90	
<b>Mechanical properties</b>				
ASTM-D 638 ISO R/527 DIN 53455	Tensile yield stress	N/mm <sup>2</sup>	195	115
ASTM-D 638 ISO R/527 DIN 53457	Ultimate elongation	%	2.6	4
ASTM-D 790 ISO 178 DIN 53452	Tensile modulus of elasticity	N/mm <sup>2</sup>	10600	6900
ASTM-D 790 ISO 178 DIN 53452	Flexural strength	N/mm <sup>2</sup>	310	190
ASTM-D 790 ISO 178	Flexural modulus	N/mm <sup>2</sup>	10500	6800
ASTM-D 256	Unnotched Izod impact strength	J/m	140	300
ISO 180/4C	Notched impact strength	KJ/m <sup>2</sup>	110	125
ASTM-D 785	Rockwell hardness	Scala R	122	114

**Dry**  
H<sub>2</sub>O < 0,15%

**Conditioned**  
equilibrium moisture content  
at 23° - 50% R.H.



## Chemical Resistance

Chemical agents	BRYLON 6			STEEL	
	Concentration %	Amorphous	Crystal	Concentration %	
Methyl acetate	100	RB3	RB2	100	RB
Acetone	100	RB4	RB	100	RB
Acetic acid (aqueous solution)	40	AF	AF	40	AF
Acetic acid (aqueous solution)	10	AF	AF	10	AF
Acetic acid		AF	AF		AF
Citric acid	10	AD 15	RD	10	AD
Hydrochloric acid (aqueous solution)	36	S	S	36	S
Hydrochloric acid (aqueous solution)	10	AF	AF	10	S
Hydrochloric acid (aqueous solution)	2	AF	AD	2	S
Chromic acid (aqueous solution)	10	AF	AF	10	AF
Chromic acid (aqueous solution)	1	RD	RD	1	AF
Hydrofluoric acid	40	AF	AF	40	S
Formic acid (aqueous solution)	85 S	S		85 S	AD
Formic acid (aqueous solution)	40 S	AF	AF	40 S	AD
Phosphoric acid (aqueous solution)	10	AF	AF	10	S
Oleic acid	100	RB3	RB3	100	RD
Sulphuric acid	98	S	S	98	S
Sulphuric acid (aqueous solution)	40	AF	AF	40	S
Sulphuric acid (aqueous solution)	10	AF	AF	10	S
Sulphuric acid (aqueous solution)	2	AF	AD	2	S
Tartaric acid (aqueous solution)		RD	RB		RD
Water		RB10	RB9		RD
Chlorine water		RD	RD		AD
Ethyl alcohol	96	RD17	RB3	96	RB
Ammonia	10	RB11	RB	10	AF
Petrol	100	RB1	RB	100	RB
Bitumen		RD	RD		RB
Potassium carbonate	100	RB	RB	100	AF
Sodium carbonate	10	RB10	RB3	10	AF
Ammonium chloride (aqueous solution)	10	RB	RB	10	AF
Calcium chloride (aqueous solution)	20	S	S	20	AF
Calcium chloride (aqueous solution)	10	RB	RB	10	AF
Sodium chloride	10	RB	RB	10	AF
Formaldehyde (aqueous solution)	30	RD	RB	30	AD
Fat		RB	RB		RB
Milk		RB	RB		RB
Mercury		RB	RB		RB
Oils		RB	RB		RB
Oil		RB	RB		RB
Paraffin oil		RB	RB		RB
Silicon oil		RB	RB		RB
Diesel oil		RB	RB		RB
Mineral oil		RB	RB		RB
Ozone		AF	AF		AF
Oil		RB	RB		RB
Potassium hydroxide (aqueous solution)	10	RB9	RB3	10	S
Sodium hydroxide (aqueous solution)	50	RD	RD	50	S
Sodium hydroxide (aqueous solution)	10	RB5	RB	10	S
Sodium hydroxide (aqueous solution)	5	RB9	RB	5	S
Aluminium sulphate	10	RB	RB	10	AF
Soap (aqueous solution)		RB	RB		RB
Tincture of iodine		AF	AF		AD
Trichlorethylene		RD5	RD4		RB
Vaseline		RB	RB		RB

The table shows the resistance to chemical agents of BRYLON 6 and Steel.

**RB**  
Very good resistance.

**RD**  
Good resistance.

**AD**  
Limited resistance.

**AF**  
Poor resistance.

**S**  
Soluble.

**Amorphous**  
Polymer in amorph state.

**Crystal**  
Polymer in crystalline state.

The number by resistance value side shows which is the % weight increase due to swelling.

All data contained in this publication are laboratory and design values, to be verified in practical applications.





# Nylon Cable Chain

Light Series	page 38
Medium Series	page 58
Heavy Series	page 86
Protection Series	page 112
Sliding Series	page 134
Robot Series	page 164



# Nylon Cable Chains Light Series

Series SR200	page 40
Series SR250	page 42
Series SR30090-SR30091-SR30092	page 44
Series SR325LI/LE	page 46
Series SR325A	page 48
Series SR325	page 50
Series SR339	page 52 <b>New</b>
Channel guide for long travel distance	
For series SR30090-SR30091-SR30092-SR300	page 54
For series SR325LI-SR325LE-SR325A-SR325-SR339	page 56

*Inner surface of chain  
completely smooth*

*Steel or nylon end brackets with  
tiewrap clamp*



*Cross pieces open and close with a "Snap-Fit" action*

*Nylon separator. Cables can be laid apart from each other*

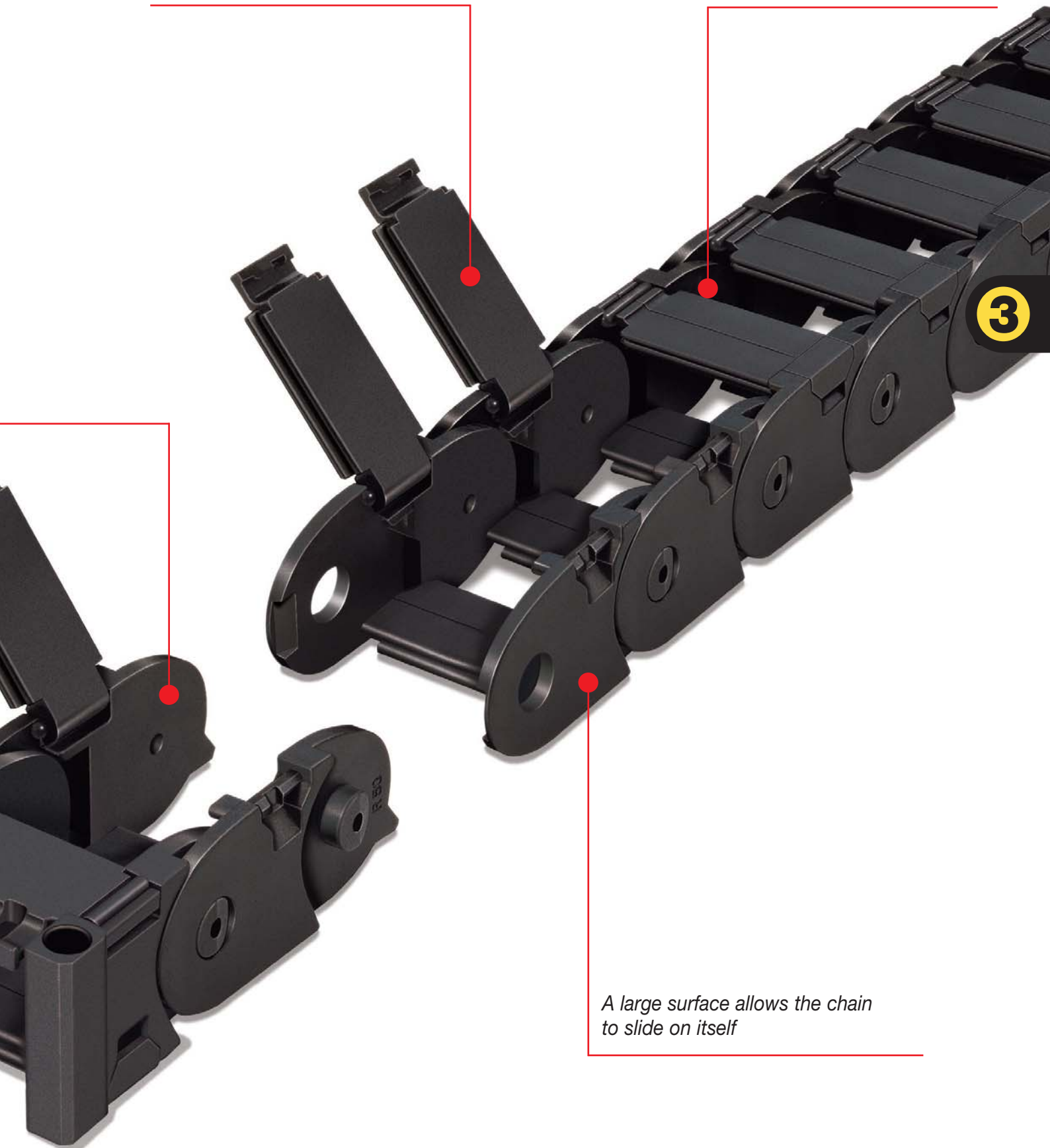

*A large surface allows the chain to slide on itself*

# Serie Light

# SR200 Nylon Cable Chain

## Inner height (D) 12 mm

Single link construction with central anti-friction pivot. Not openable. Very smooth chain, particularly suitable for small automatic machines like printers, measurements equipment etc.

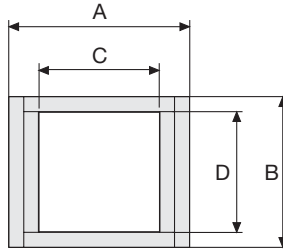

## Technical characteristics when self-supported

Speed	10 m/s
Acceleration	50 m/s <sup>2</sup>

For higher requirements please consult our technical dept.

A	B	C	D	R	Weight/m	Chain
mm	mm	mm	mm	mm	kg	Part Number
18	15	12	12	018-030-040	0,13	SR20012□□□*
31	15	25	12	018-030-040	0,14	SR20025□□□*
41	15	35	12	018-030-040	0,15	SR20035□□□*

\*Complete the code by inserting the value of the radius (R): Ex. SR20012 □ □ □ □

3

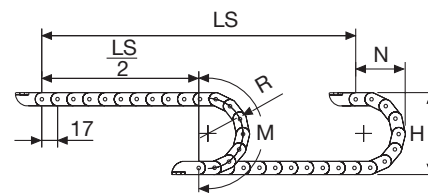

R	H	N	M
mm	mm	mm	mm
018	51	45	95
030	75	55	130
040	95	70	165

Length of chain (L)  
Half travel distance ( $\frac{LS}{2}$ )  
plus length of curve (M)

$$L = \frac{LS}{2} + M$$





### Self-Supporting Capacity Diagram

The maximum length of the self-supporting capacity ( $\frac{LS}{2}$ ) in relationship to the weight of the cables and hoses contained per linear metre.

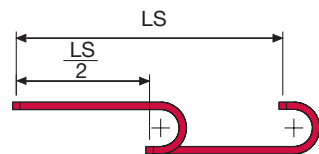
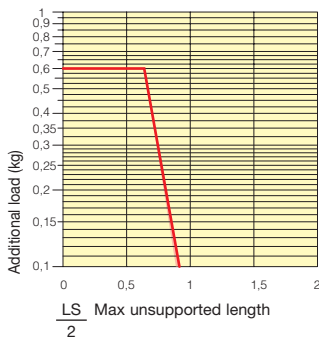

The red marking in the diagram area considers the difference of weight between various widths of chain.

For applications with  $\frac{LS}{2}$  and weights not included in the area of the diagram showing self-supporting capacity, verify the possible use of support rollers (see page 30).

### End Brackets

The end brackets set allows the two ends of the chain to be attached to the equipment.

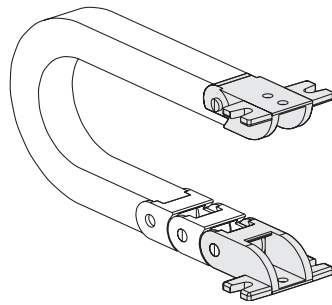
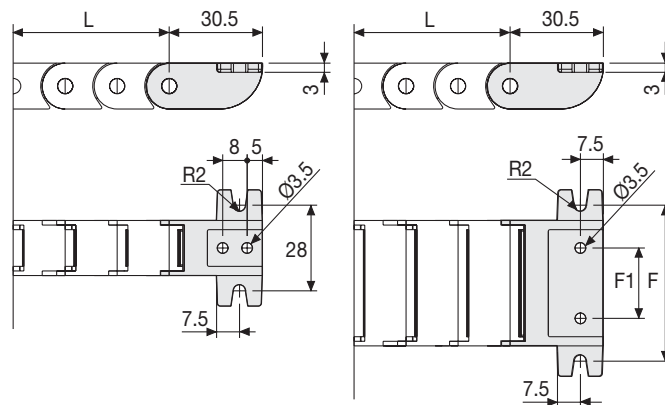

Fig. A  
Chain fixed outside the radius. (Fig A)



Chain Type	F1 mm	F mm
SR20025...	13	41
SR20035...	23	51

### Nylon Type Part Numbers

Complete Set Assembled	
Chain Type	End Brackets Set
SR20012...	AN20012KM
SR20025...	AN20025KM
SR20035...	AN20035KM

Complete Set Unassembled	
Chain Type	End Brackets Set
SR20012	AN20012K
SR20025...	AN20025K
SR20035...	AN20035K

Serie Light

**SR200**  
Nylon Cable Chain

3

For further information please consult Brevetti Stendalto's Technical Office

# Serie Light

## SR250 Nylon Cable Chain

### Inner height (D) 18 mm

Single link construction. Not openable  
Very smooth chain, particularly suitable  
for small automatic machines like  
printers, measurements equipment etc.

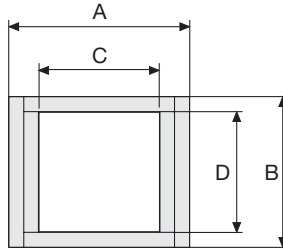

### Technical characteristics when self-supported

Speed	10 m/s
Acceleration	50 m/s <sup>2</sup>

For higher requirements please consult our  
technical dept.

A	B	C	D	R	Weight/m	Chain
mm	mm	mm	mm	mm	kg	Part Number
23	22	15	18	40	0,25	SR25040

3

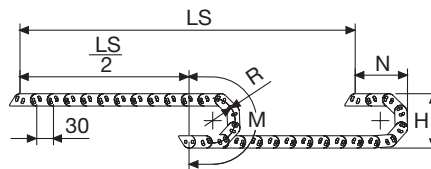

R	H	N	M
mm	mm	mm	mm
40	102	80	185

Length of chain (L)  
Half travel distance ( $\frac{LS}{2}$ )  
plus length of curve (M)

$$L = \frac{LS}{2} + M$$



### Self-Supporting Capacity Diagram

The maximum length of the self-supporting capacity ( $\frac{LS}{2}$ ) in relationship to the weight of the cables and hoses contained per linear metre.

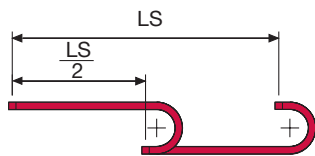
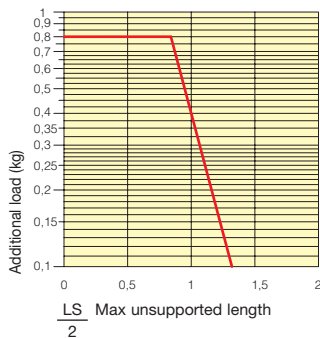

The red marking in the diagram area considers the difference of weight between various widths of chain.

For applications with  $\frac{LS}{2}$  and weights not included in the area of the diagram showing self-supporting capacity, verify the possible use of support rollers (see page 30).

### End Brackets

The end brackets set allows the two ends of the chain to be attached to the equipment.

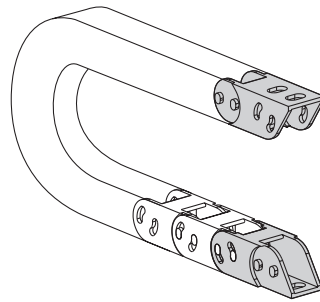
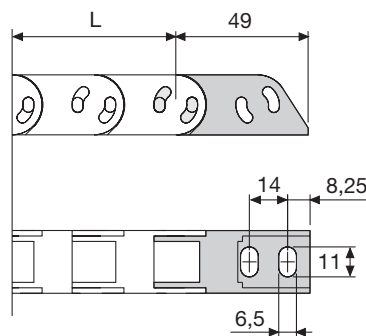

Fig. A  
Chain fixed outside the radius. (Fig A)  
See end brackets mounting variations page 31.



### Nylon Type Part Numbers

Complete Set Assembled	
Chain	End Brackets
Type	Set
SR250	AN250KM□**

Complete Set Unassembled	
Chain	End Brackets
Type	Set
SR250	AN250K

\*\* 1=Pos.1; 2=Pos.2; 3=Pos.3  
See end brackets mounting variations page 31.

Serie Light

**SR250**  
Nylon Cable Chain



### Self-Supporting Capacity Diagram

The maximum length of the self-supporting capacity ( $\frac{LS}{2}$ ) in relationship to the weight of the cables and hoses contained per linear metre.

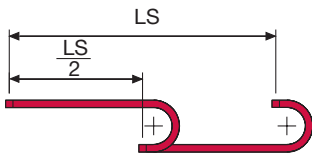
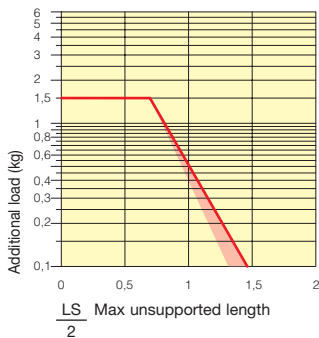

The red marking in the diagram area considers the difference of weight between various widths of chain.

For applications with  $\frac{LS}{2}$  and weights not included in the area of the diagram showing self-supporting capacity, verify the possible use of support rollers (see page 30).

### Bright Zinc Plated Steel End Brackets\*

The end brackets set allows the two ends of the chain to be attached to the equipment.

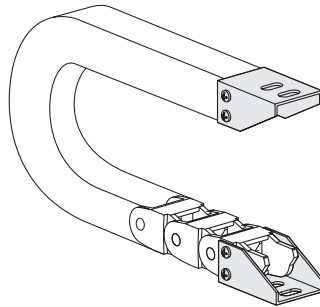
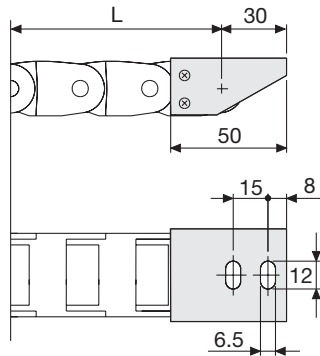

Fig. A  
Chain fixed outside the radius. (Fig A)  
See end brackets mounting variations page 31.



### Bright Zinc Plated Steel Type Part Numbers

Complete Set Assembled	
Chain	End Brackets
Type	Set
SR30090	A30090KM □**
SR30091	A30091KM □**
SR30091S	A30091KM □**
SR30092	A30092KM □**

Complete Set Unassembled	
Chain	End Brackets
Type	Set
SR30090	A30090K □**
SR30091	A30091K □**
SR30091S	A30091K □**
SR30092	A30092K □**

\*Available on request in stainless steel  
\*\* 1=Pos.1; 2=Pos.2; 3=Pos.3  
See end brackets mounting variations page 31.

### Serie Light

**SR30090**  
**SR30091**  
**SR30092**  
Nylon Cable Chain

3

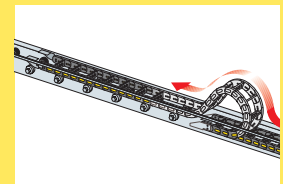

Suitable to long travel distance.  
To choose the guide channel see page 54

For further information please consult Brevetti Stendalto's Technical Office

# Serie Light

## SR325LI/SR325LE Nylon Cable Chain with openable frames

### Inner height (D) 25 mm

Single link construction with central large anti-friction pivot, for high torsion and tensile resistance.

Frames openable from inner radius (SR325LI) or from outer radius (SR325LE). Vertical separators available. Used with guide channels, this chain is particularly suitable for long distance travel.

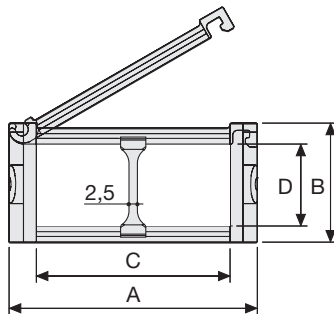

### Separator

- Unassembled	Part.no S325L
- Assembled	Part.no S325LMC

### Technical characteristics when self-supported

Speed	10 m/s
Acceleration	50 m/s <sup>2</sup>

For higher requirements please consult our technical dept.

A	B	C	D	R	Weight/m	Chain
mm	mm	mm	mm	mm	kg	Part Number
57	38	40	25	050-060-075-100-125-150	0,90	SR325LI(LE)040□□□*
77	38	60	25	050-060-075-100-125-150	0,95	SR325LI(LE)060□□□*
93	38	76	25	050-060-075-100-125-150	1,05	SR325LI(LE)076□□□*
120	38	103	25	050-060-075-100-125-150	1,15	SR325LI(LE)103□□□*

\*Complete the code by inserting the value of the radius (R): Ex. SR325LI040 □ □ □ □

For sliding applications, technical data can slightly change according to frequency, added weight and environment.

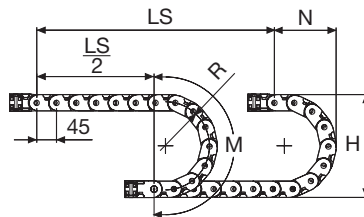

R	H	N	M	N1	M1
mm	mm	mm	mm	mm	mm
050	138	115	250	145	300
060	158	125	280	155	335
075	188	140	325	185	420
100	238	165	405	275	635
125	288	190	485	360	855
150	338	215	565	445	1075

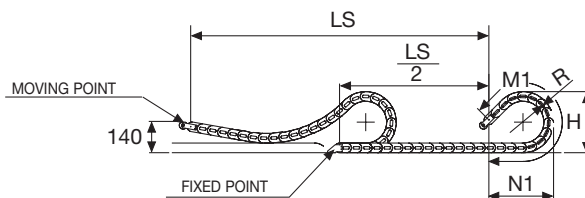

Length of chain (L)  
Half travel distance ( $\frac{LS}{2}$ )  
plus length of curve (M) or (M1)

$$L = \frac{LS}{2} + M \text{ o } M1$$



### Self-Supporting Capacity Diagram

The maximum length of the self-supporting capacity ( $\frac{LS}{2}$ ) in relationship to the weight of the cables and hoses contained per linear metre.

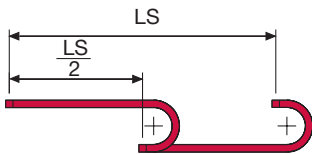
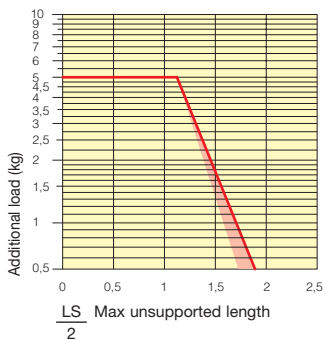

The red marking in the diagram area considers the difference of weight between various widths of chain.

For applications with  $\frac{LS}{2}$  and weights not included in the area of the diagram showing self-supporting capacity, verify the possible use of support rollers (see page 30).

### End Brackets

The end brackets set allows the two ends of the chain to be attached to the equipment. Set complete with tiewrap clamps available on request.

#### Nylon Type

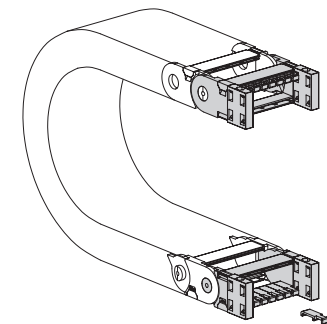

Fig. A Chain fixed outside/inside the radius. (Fig A)

#### Bright Zinc Plated Steel Type\*

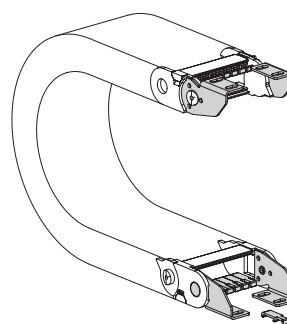
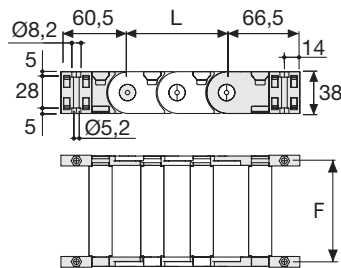
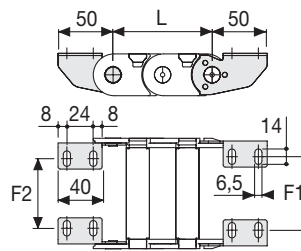

Fig. B Chain fixed outside the radius. (Fig B) See end brackets mounting variations page 31.



Chain Type	F mm
SR325L...040	51
SR325L...060	71
SR325L...076	87
SR325L...103	114



Chain Type	F2 mm	F1 mm
SR325L...040	20	23,5
SR325L...060	40	43,5
SR325L...076	56	59,5
SR325L...103	83	86,5

### Nylon Type Part Numbers

Complete Set Assembled Chain Type	End Brackets Set
SR325L...	AN325L□□□*KM

Complete Set Unassembled Chain Type	End Brackets Set
SR325L...	AN325L□□□*K

Tiewrap Clamp Part Number
Assembled
SFC325L□□□*KM
Unassembled
SFC325L□□□*K

\* Complete the code by inserting the value of the quote C.

### Bright Zinc Plated Steel Type Part Numbers

Complete Set Assembled Chain Type	End Brackets Set
SR325L...	A325LK**

\*Available on request in stainless steel  
\*\*See end brackets mounting variations page 31.

### Serie Light

## SR325LI SR325LE

Nylon Cable Chain  
with openable frames

3

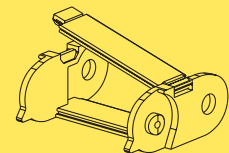
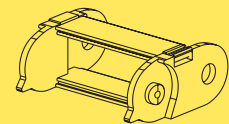

How to open the cover.

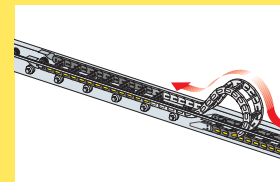

Suitable to long travel distance. To choose the guide channel see page 56

For further information please consult Brevetti Stendalto's Technical Office

# Serie Light

## SR325A Nylon Cable Chain with openable frames

### Inner height (D) 25,5 mm

Single link construction with central large anti-friction pivot, for high torsion and tensile resistance.

Frames openable from outer radius.

Vertical separators available. The chain is one of the strongest 25 mm standard chains. Used with guide channels, this chain is particularly suitable for long distance travel.

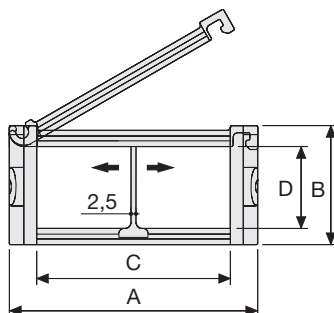

### Separator

- Unassembled	Part.no S325.1
- Assembled	Part.no S325.1MC

### Technical characteristics when self-supported

Speed	10 m/s
Acceleration	50 m/s <sup>2</sup>

For higher requirements please consult our technical dept.

A	B	C	D	R	Weight/m	Chain
mm	mm	mm	mm	mm	kg	Part Number
57	37	40	25,5	050-060-075-100-125-150	0,90	SR325A040□□□*
77	37	60	25,5	050-060-075-100-125-150	1,00	SR325A060□□□*
93	37	76	25,5	050-060-075-100-125-150	1,10	SR325A076□□□*
120	37	103	25,5	050-060-075-100-125-150	1,25	SR325A103□□□*

\*Complete the code by inserting the value of the radius (R): Ex. SR325A040 □ □ □ □

For sliding applications, technical data can slightly change according to frequency, added weight and environment.

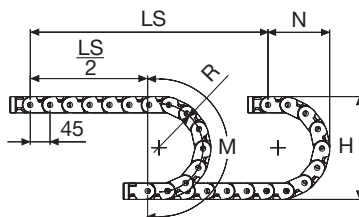

R	H	N	M	N1	M1
mm	mm	mm	mm	mm	mm
050	137	115	250	145	300
060	157	125	280	155	335
075	187	140	325	185	420
100	237	165	405	275	635
125	287	190	485	360	855
150	337	215	565	445	1075

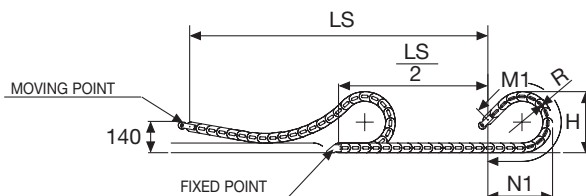

Length of chain (L)  
Half travel distance ( $\frac{LS}{2}$ )  
plus length of curve (M) or (M1)

$$L = \frac{LS}{2} + M \text{ or } M1$$

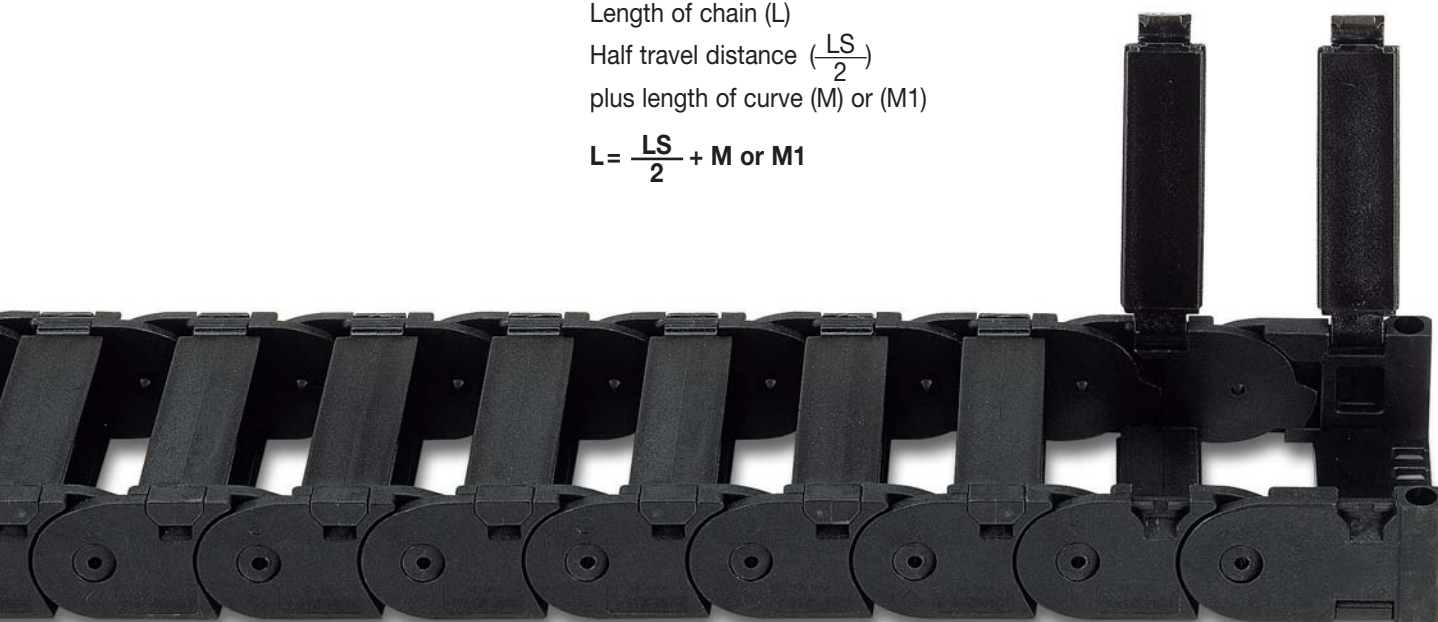



### Self-Supporting Capacity Diagram

The maximum length of the self-supporting capacity ( $\frac{LS}{2}$ ) in relationship to the weight of the cables and hoses contained per linear metre.

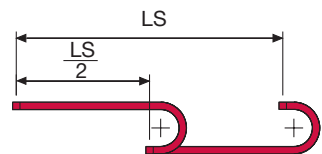
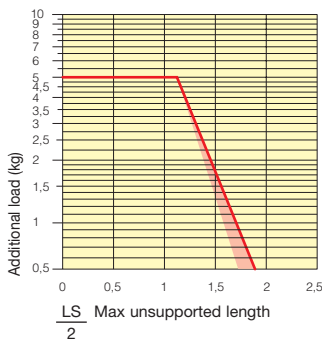

The red marking in the diagram area considers the difference of weight between various widths of chain.

For applications with  $\frac{LS}{2}$  and weights not included in the area of the diagram showing self-supporting capacity, verify the possible use of support rollers (see page 30).

### End Brackets

The end brackets set allows the two ends of the chain to be attached to the equipment. The set also includes the tiewrap clamp for cable fixing.

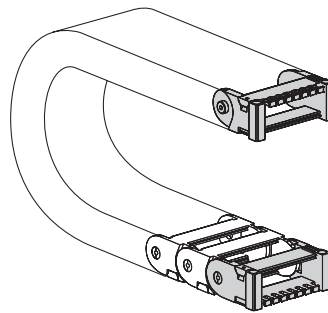

Fig. A Chain fixed outside/inside the radius. (Fig A)

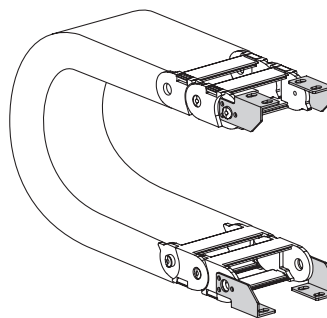
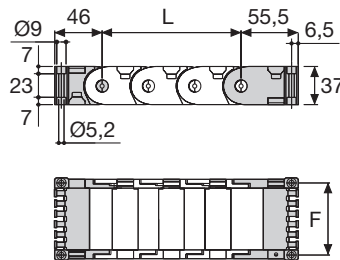

Fig. B Chain fixed outside the radius. (Fig B) See end brackets mounting variations page 31.



Chain Type	F mm
SR325A040	51
SR325A060	71
SR325A076	87
SR325A103	114

### Nylon Type Part Numbers

Complete Set Assembled Chain Type	End Brackets Set
SR325A040	AN325A040KM
SR325A060	AN325A060KM
SR325A076	AN325A076KM
SR325A103	AN325A103KM

Complete Set Unassembled Chain Type	End Brackets Set
SR325A040	AN325A040K
SR325A060	AN325A060K
SR325A076	AN325A076K
SR325A103	AN325A103K

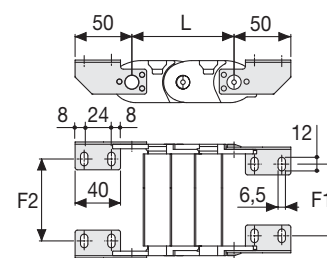

Chain Type	F2 mm	F1 mm
SR325A040	31	22
SR325A060	51	42
SR325A076	67	58
SR325A103	94	85

### Bright Zinc Plated Steel Type Part Numbers

Complete Set Assembled Chain Type	End Brackets Set
SR325A040	AS325A040KM <input type="checkbox"/> **
SR325A060	AS325A060KM <input type="checkbox"/> **
SR325A076	AS325A076KM <input type="checkbox"/> **
SR325A103	AS325A103KM <input type="checkbox"/> **

Complete Set Unassembled Chain Type	End Brackets Set
SR325A040	AS325A040K <input type="checkbox"/> **
SR325A060	AS325A060K <input type="checkbox"/> **
SR325A076	AS325A076K <input type="checkbox"/> **
SR325A103	AS325A103K <input type="checkbox"/> **

\*Available on request in stainless steel  
\*\* 1=Pos.1; 2=Pos.2; 3=Pos.3  
See end brackets mounting variations page 31.

### Serie Light

## SR325A

Nylon Cable Chain with openable frames

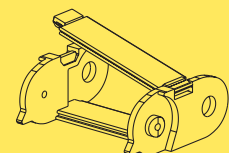
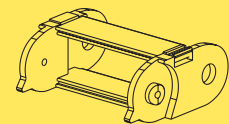

How to open the cover.

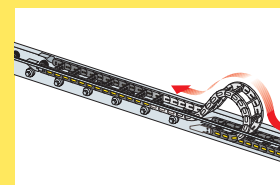

Suitable to long travel distance. To choose the guide channel see page 56

For further information please consult Brevetti Stendalto's Technical Office

# Serie Light

# SR325 Nylon Cable Chain

## Inner height (D) 25,5 mm

Single link construction with central large anti-friction pivot, for high torsion and tensile resistance. Not openable. Used with guide channels, this chain is particularly suitable for long distance travel, as typical for example in larger textile plants.

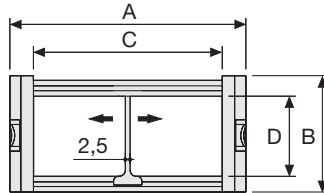

## Separator

- Unassembled	Part.no S325.1
- Assembled	Part.no S325.1MC

## Technical characteristics when self-supported

Speed	10 m/s
Acceleration	50 m/s <sup>2</sup>

For higher requirements please consult our technical dept.

A	B	C	D	R	Weight/m	Chain
mm	mm	mm	mm	mm	kg	Part Number
55	37	40	25,5	050-060-075-100-125-150	0,83	SR325040□□□*
75	37	60	25,5	050-060-075-100-125-150	0,95	SR325060□□□*
91	37	76	25,5	050-060-075-100-125-150	1,06	SR325076□□□*
118	37	103	25,5	050-060-075-100-125-150	1,12	SR325103□□□*

\*Complete the code by inserting the value of the radius (R): Ex. SR325040 □□□□

For sliding applications, technical data can slightly change according to frequency, added weight and environment.

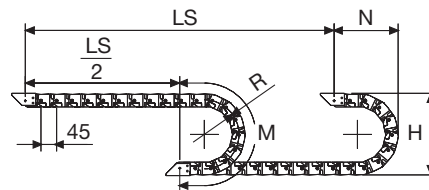

R	H	N	M	N1	M1
mm	mm	mm	mm	mm	mm
050	137	115	250	145	300
060	157	125	280	155	335
075	187	140	325	185	420
100	237	165	405	275	635
125	287	190	485	360	855
150	337	215	565	445	1075

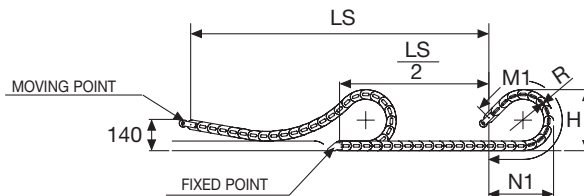

Length of chain (L)  
Half travel distance ( $\frac{LS}{2}$ )  
plus length of curve (M) or (M1)

$$L = \frac{LS}{2} + M \text{ or } M1$$

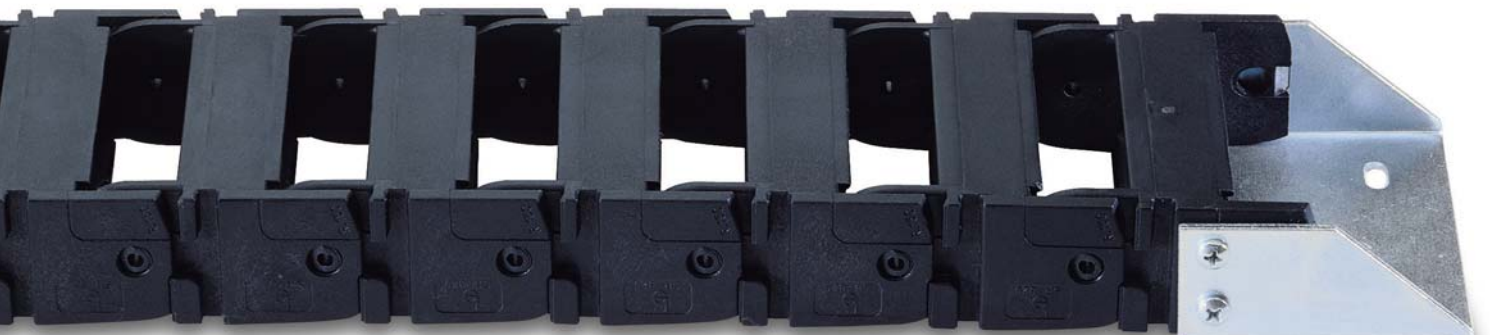

### Self-Supporting Capacity Diagram

The maximum length of the self-supporting capacity ( $\frac{LS}{2}$ ) in relationship to the weight of the cables and hoses contained per linear metre.

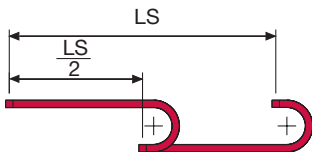
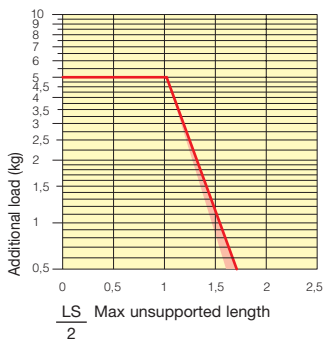

The red marking in the diagram area considers the difference of weight between various widths of chain.

For applications with  $\frac{LS}{2}$  and weights not included in the area of the diagram showing self-supporting capacity, verify the possible use of support rollers (see page 30).

### Bright Zinc Plated Steel End Brackets\*

The end brackets set allows the two ends of the chain to be attached to the equipment.

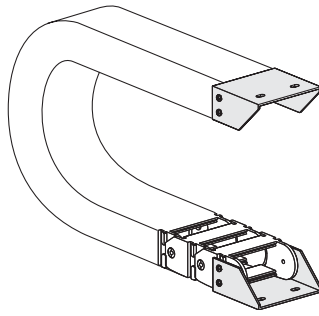
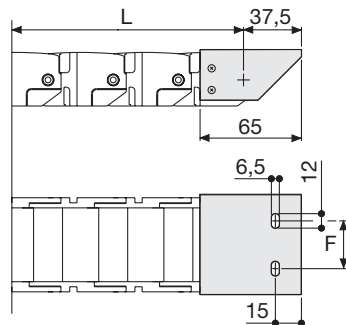

Fig. A  
Chain fixed outside the radius. (Fig A)  
See end brackets mounting variations page 31.



Chain Type	F mm
SR325040	24
SR325060	44
SR325076	60
SR325103	87

### Bright Zinc Plated Steel Type Part Numbers

Complete Set Assembled	
Chain Type	End Brackets Set
SR325040	A325040KM □**
SR325060	A325060KM □**
SR325076	A325076KM □**
SR325103	A325103KM □**

Complete Set Unassembled	
Chain Type	End Brackets Set
SR325040	A325040K □**
SR325060	A325060K □**
SR325076	A325076K □**
SR325103	A325103K □**

\*Available on request in stainless steel

\*\* 1=Pos.1; 2=Pos.2; 3=Pos.3

See end brackets mounting variations page 31.

Serie Light

**SR325**  
Nylon Cable Chain

3

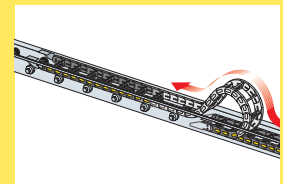

Suitable to long travel distance.  
To choose the guide channel see page 56

For further information please consult Brevetti Stendalto's Technical Office

# SR339 Nylon Cable Chain

## Inner height (D) 39 mm

Single link construction with central large anti-friction pivot, for high torsion and tensile resistance. Not openable version. Short pitch and very small bending radius design makes these chains suitable for applications with the smallest available spaces. These series can be easily used for long distance travels with the corresponding guide channels.

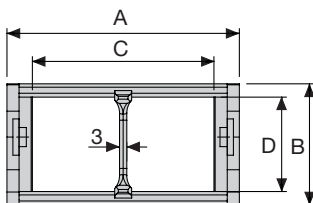

### Separator

- Unassembled	Part.no S339
- Assembled	Part.no S339MC

### Technical characteristics when self-supported

Speed	10 m/s
Acceleration	50 m/s <sup>2</sup>

For higher requirements please consult our technical dept.

A	B	C	D	R	Weight/m	Chain
mm	mm	mm	mm	mm	kg	Part Number
60	50	40	39	50-75-100	1,48	SR339040□□□*
80	50	60	39	50-75-100	1,48	SR339060□□□*
96	50	76	39	50-75-100	1,65	SR339076□□□*

\*Complete the code by inserting the value of the radius (R): Ex. SR339076 □□□□

For sliding applications, technical data can slightly change according to frequency, added weight and environment.

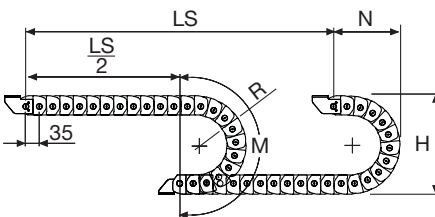

R	H	N	M	N1	M1
mm	mm	mm	mm	mm	mm
050	150	170	340	140	275
060	200	180	370	215	470
075	250	195	420	310	705

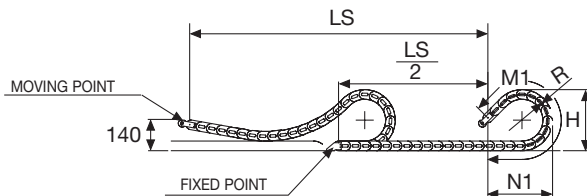

Length of chain (L)  
Half travel distance ( $\frac{LS}{2}$ )  
plus length of curve (M) or (M1)

$$L = \frac{LS}{2} + M \text{ or } M1$$



### Self-Supporting Capacity Diagram

The maximum length of the self-supporting capacity ( $\frac{LS}{2}$ ) in relationship to the weight of the cables and hoses contained per linear metre.

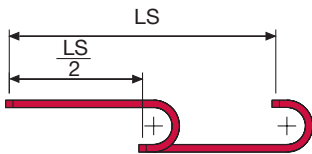
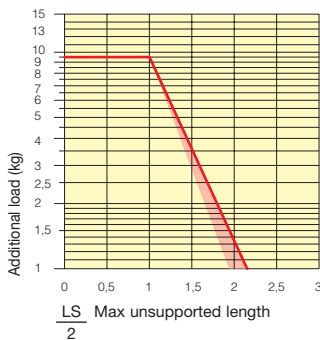

The red marking in the diagram area considers the difference of weight between various widths of chain.

For applications with  $\frac{LS}{2}$  and weights not included in the area of the diagram showing self-supporting capacity, verify the possible use of support rollers (see page 30).

### Bright Zinc Plated Steel End Brackets\*

The end brackets set allows the two ends of the chain to be attached to the equipment.

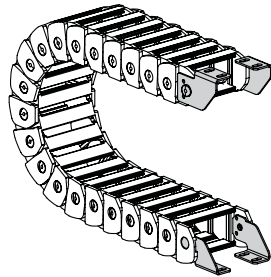
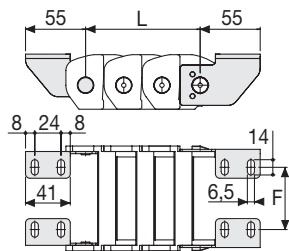

Fig. A  
Chain fixed outside the radius. (Fig A)  
See end brackets mounting variations page 31



Chain Type	F mm
SR339040	21
SR339060	41
SR339076	57

### Bright Zinc Plated Steel Type Part Numbers

Complete Set Unassembled Chain Type	End Brackets Set
SR339...	A339K

\*Available on request in stainless steel  
See end brackets mounting variations page 31.

### Serie Light

## SR339 Nylon Cable Chain

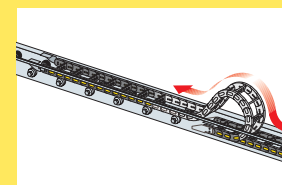

Suitable to long travel distance.  
To choose the guide channel see page 56

For further information please consult Brevetti Stendalto's Technical Office

# Serie Light

# Guide Channel

## SR30090-SR30091-SR30092-SR300

Special channel guide allows the use of the chain for long travel distance. Available in galvanised steel and, on request, in stainless steel.

### Single Chain Application

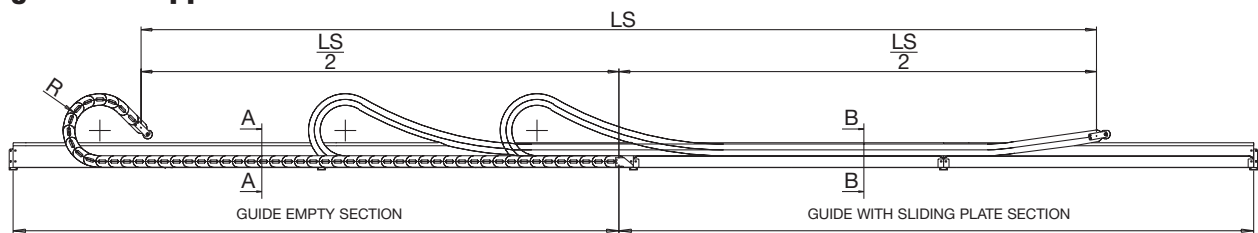

### Double Chain Application

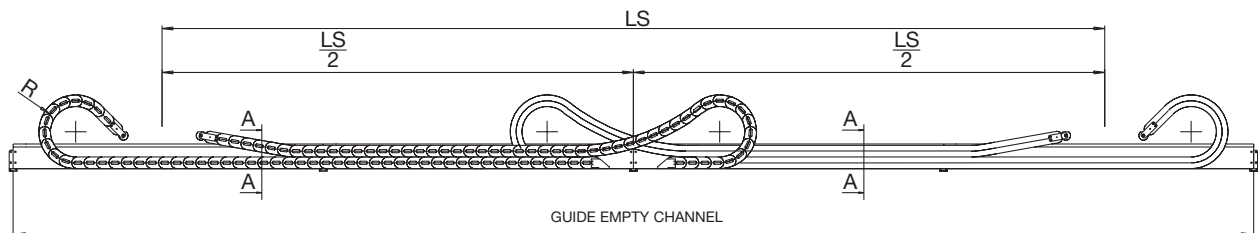

Channel guide is available in kit form composed of:  
side walls 2 m standard length  
joining plates  
fixing screws

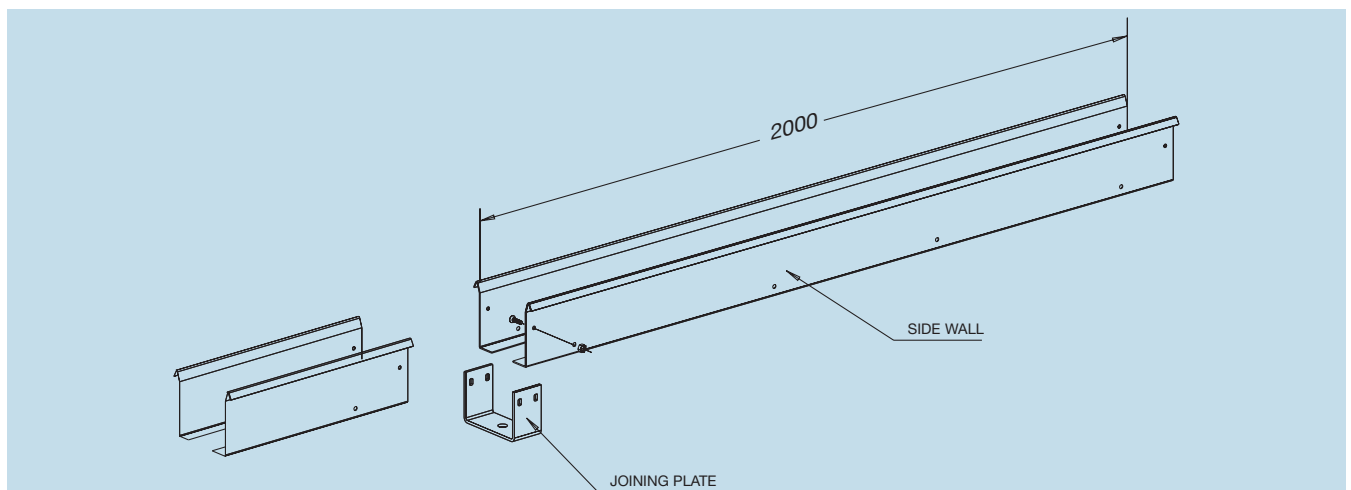

## Guide Empty Section

Section A-A

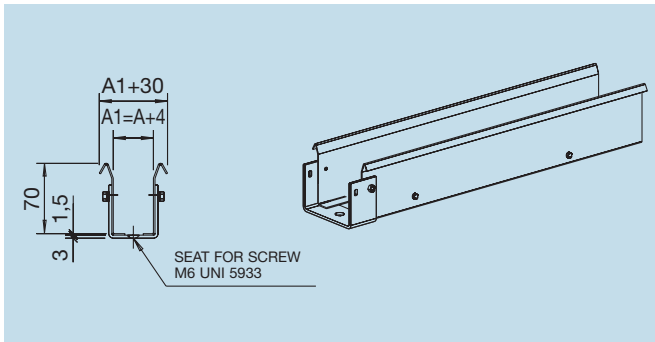

### Part Number

**CS30090...**

How to order

Chain part number **SR30090038**

Guide channel  
part number **CS30090**

**CS30091...**

How to order

Chain part number **SR30091038**

Guide channel  
part number **CS30091**

## Guide Sliding Plate Section

Section B-B

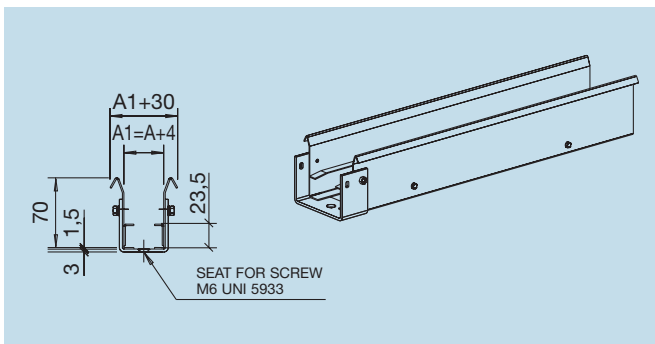

### Part Number

**CA30090...**

How to order

Chain part number **SR30090038**

Guide channel  
part number **CA30090**

**CA30091...**

How to order

Chain part number **SR30091038**

Guide channel  
part number **CA30091**

# Serie Light

# Guide Channel

## SR325LI-SR325LE-SR325A-SR325-SR339

Special channel guide allows the use of the chain for long travel distance. Available in galvanised steel and, on request, in stainless steel.

### Single Chain Application

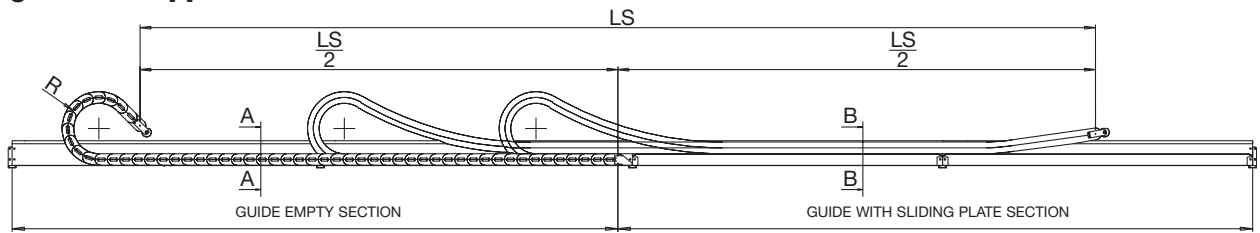

### Double Chain Application

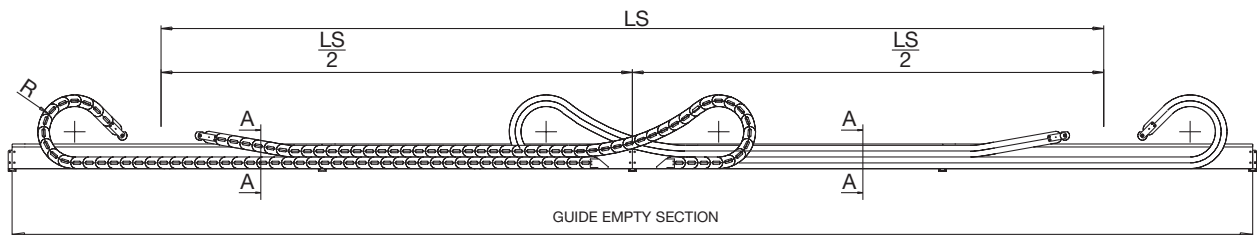

Channel guide is available in kit form composed of:  
side walls 2 m standard length  
joining plates  
fixing screws

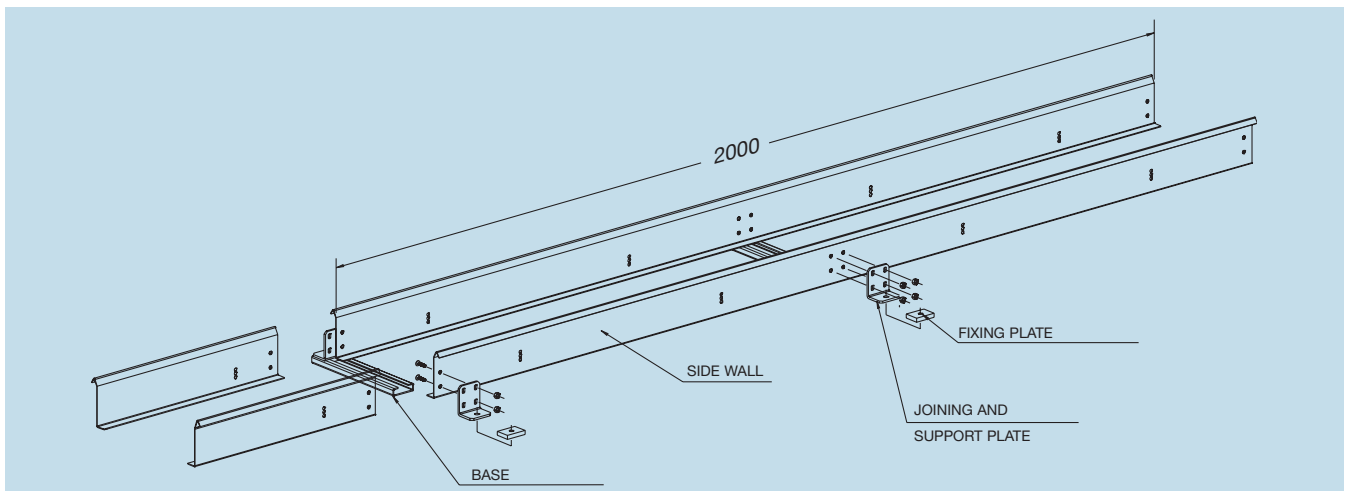



### Guide Empty Section

Section A-A

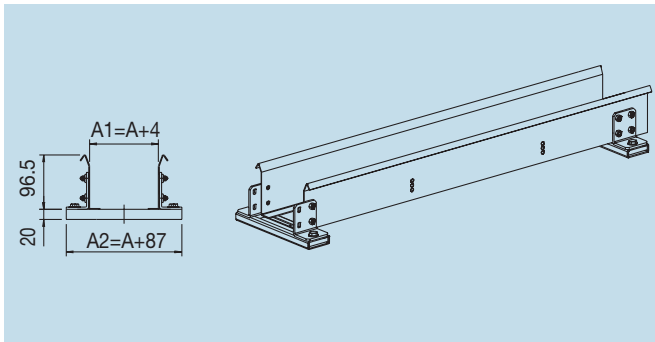

#### Part Number

**CS325...**

How to order

Chain part number **SR325040050**

Guide channel  
part number **CS325040**

**CS325A...**

How to order

Chain part number **SR325A040050**

Guide channel  
part number **CS325A040**

### Guide Sliding Plate Section SR325...

Section B-B

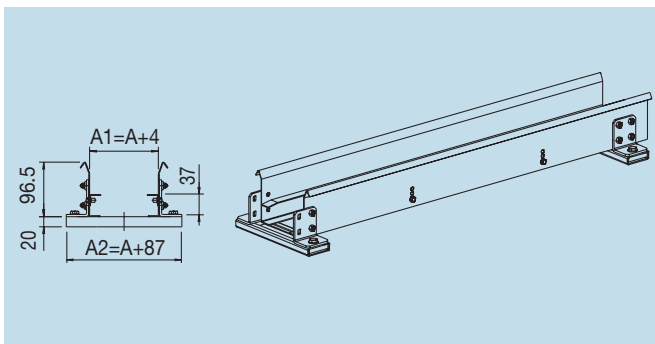

#### Part Number

**CA325...**

How to order

Chain part number **SR325040050**

Guide channel  
part number **CA325040**

**CA325A...**

How to order

Chain part number **SR325A040050**

Guide channel  
part number **CA325A040**

### Guide Sliding Plate Section SR339

Section B-B

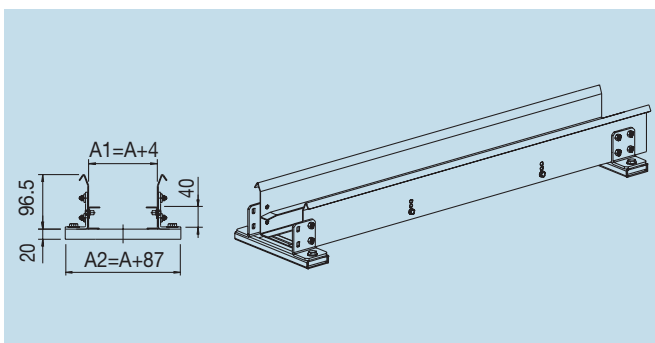

#### Part Number

**CA339...**

How to order

Chain part number **SR339040050**

Guide channel  
part number **CA339040**

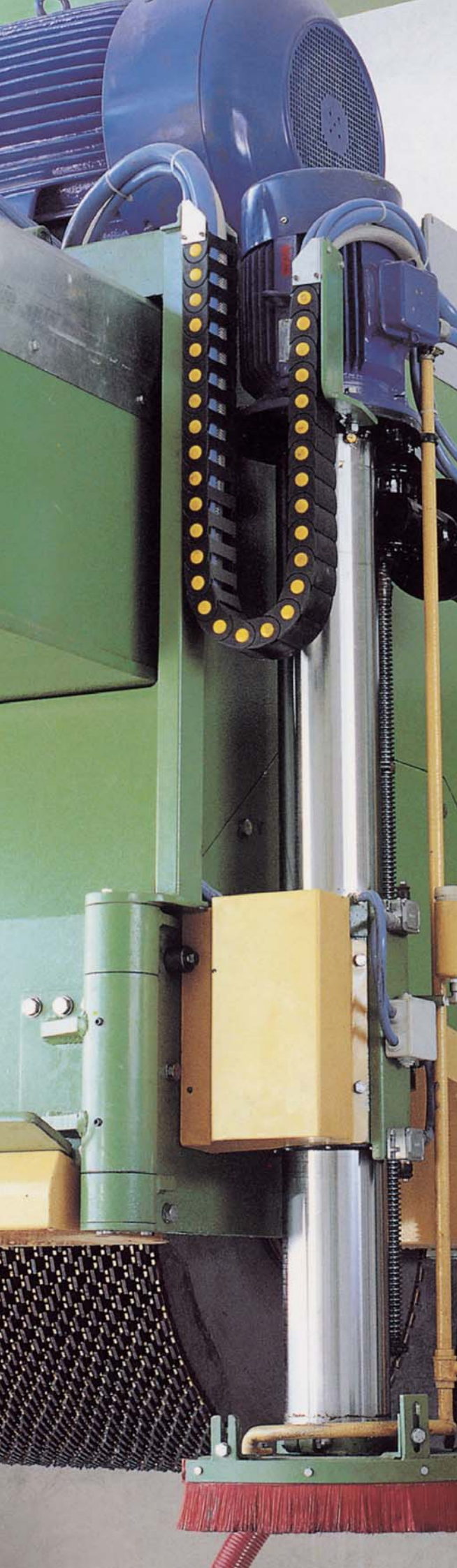

# Nylon Cable Chains Medium Series

Series SR300A	page 60
Series SR300	page 62
Series SR305A	page 64
Series SR305	page 66
Series SR355A	page 68
Series SR355	page 70
Series SR400	page 72
Series SR435MI-SR435ME	page 74
Series SR445MI-SR445ME	page 76
Series SR660A	page 78
Series SR770A	page 80
Series SR475MI-SR475ME	page 82
<hr/>	
Channel guide for long travel distance	
For chains SR305-SR355-SR435MI-SR435ME	page 84
For chains SR445MI-SR445ME-SR660A-SR770A	page 160
For chains SR475MI-SR475ME	page 162
<hr/>	
Horizontal Separation	page 176

*Tiewrap clamp for an  
optimal conduct fixing*

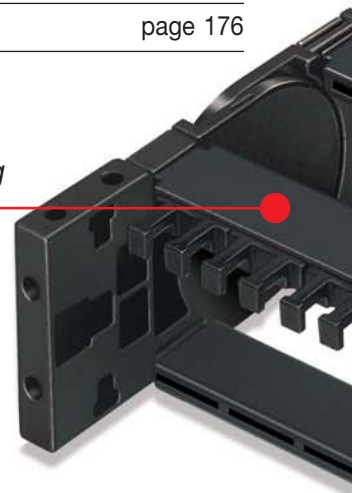

*Steel or nylon end brackets*

Cross pieces open and close with a "Snap-Fit" action

Nylon separator. Cables can be laid apart from each other

3

Single connecting Pivot Pin which offers high integrity in high performance applications

Inner surface of chain completely smooth

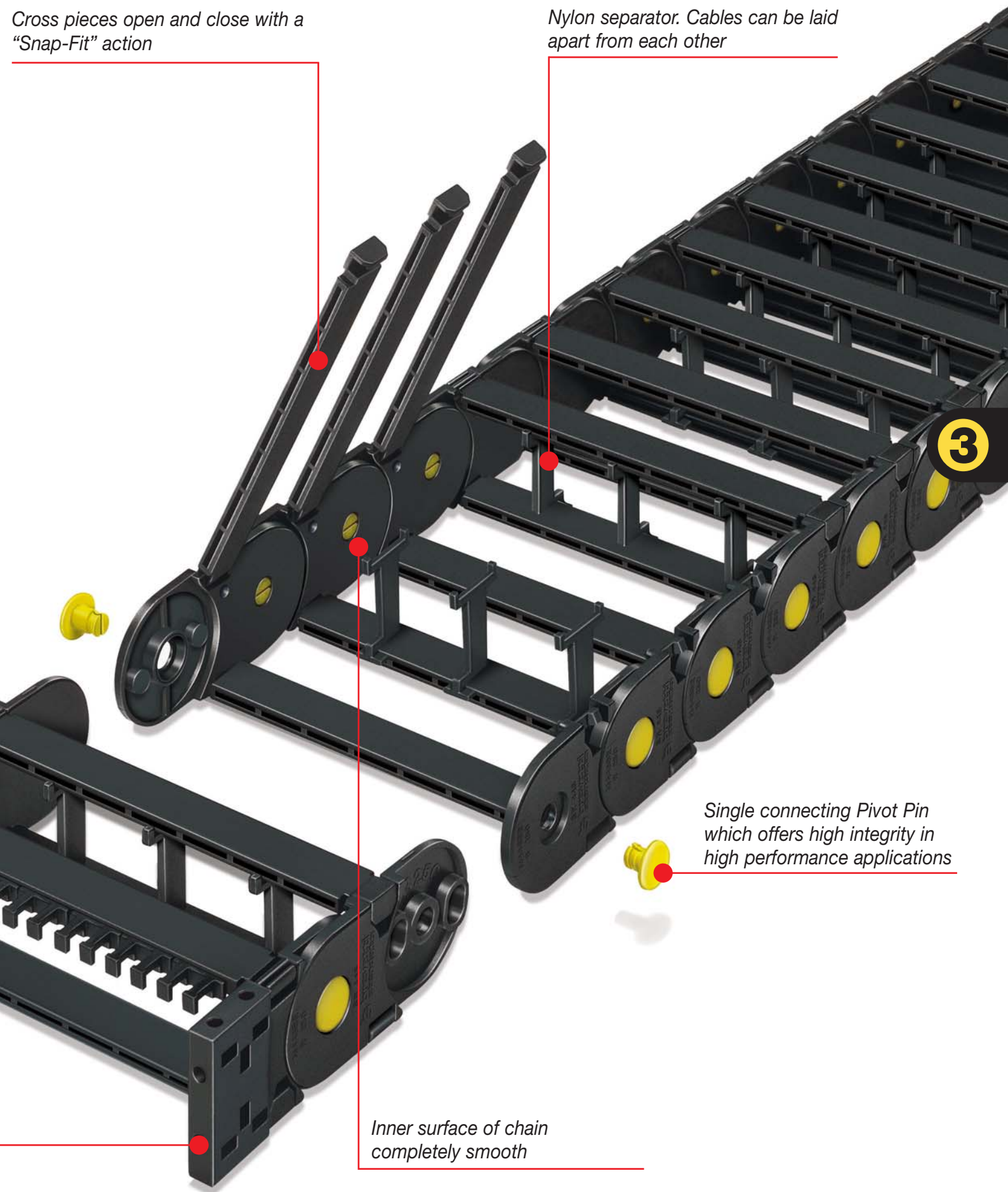

# Serie Medium

## SR300A Nylon Cable Chain with openable frames

### Inner height (D) 18 mm

Single link construction with anti-friction single-pin.  
Frames openable from inner radius.  
Vertical separators available.  
The wide frames on out radius offer good protection, when operating horizontally.

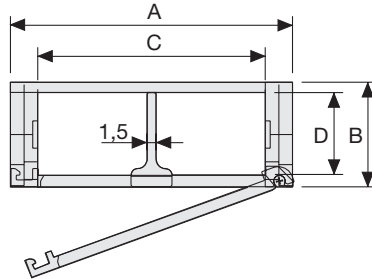

### Separator

- Unassembled	Part.no S300A
- Assembled	Part.no S300AMC

### Pin

Part.no PG300A

### Technical characteristics when self-supported

Speed	10 m/s
Acceleration	50 m/s <sup>2</sup>

For higher requirements please consult our technical dept.

A	B	C	D	R	Weight/m	Chain
mm	mm	mm	mm	mm	kg	Part Number
27	23	15	18	040-060-080-120	0,41	SR300A015□□□*
37	23	25	18	040-060-080-120	0,45	SR300A025□□□*
62	23	50	18	040-060-080-120	0,55	SR300A050□□□*
87	23	75	18	040-060-080-120	0,65	SR300A075□□□*

\*Complete the code by inserting the value of the radius (R): Ex. SR300A015 □ □ □ □

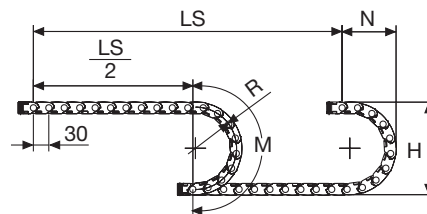

R	H	N	M
mm	mm	mm	mm
040	103	85	185
060	143	105	250
080	183	125	315
120	263	165	440

Length of chain (L)  
Half travel distance ( $\frac{LS}{2}$ )  
plus length of curve (M)

$$L = \frac{LS}{2} + M$$



### Self-Supporting Capacity Diagram

The maximum length of the self-supporting capacity ( $\frac{LS}{2}$ ) in relationship to the weight of the cables and hoses contained per linear metre.

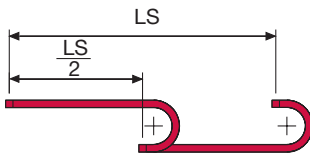
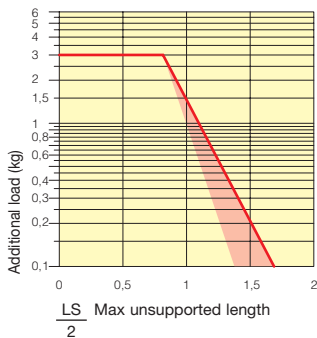

The red marking in the diagram area considers the difference of weight between various widths of chain.

For applications with  $\frac{LS}{2}$  and weights not included in the area of the diagram showing self-supporting capacity, verify the possible use of support rollers (see page 30).

### End Brackets

The end brackets set allows the two ends of the chain to be attached to the equipment.

#### Nylon Type

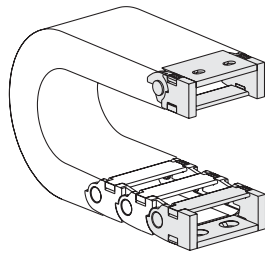

Fig. A  
Chain fixed outside the radius. (Fig A)

#### Bright Zinc Plated Steel Type\*

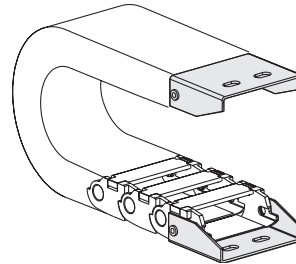
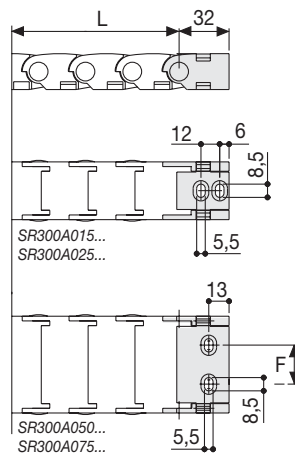

Fig. B  
Chain fixed outside the radius. (Fig B)  
See end brackets mounting variations page 31.



Chain Type	F mm
SR300A050	25
SR300A075	50

#### Nylon Type Part Numbers

Complete Set Assembled Chain Type	End Brackets Set
SR300A015	AN300A015KM
SR300A025	AN300A025KM
SR300A050	AN300A050KM
SR300A075	AN300A075KM

Complete Set Unassembled Chain Type	End Brackets Set
SR300A015	AN300A015K
SR300A025	AN300A025K
SR300A050	AN300A050K
SR300A075	AN300A075K

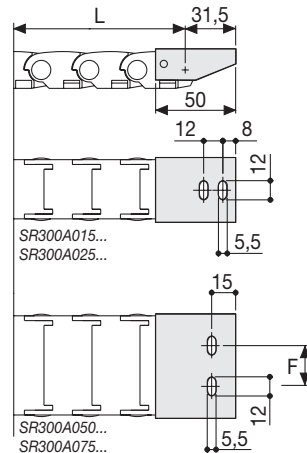

Chain Type	F mm
SR300A050	25
SR300A075	50

#### Bright Zinc Plated Steel Type Part Numbers

Complete Set Assembled Chain Type	End Brackets Set
SR300A015	A300A015KM
SR300A025	A300A025KM
SR300A050	A300A050KM
SR300A075	A300A075KM

Complete Set Unassembled Chain Type	End Brackets Set
SR300A015	A300A015K
SR300A025	A300A025K
SR300A050	A300A050K
SR300A075	A300A075K

\*Available on request in stainless steel

### Serie Medium

## SR300A

Nylon Cable Chain  
with openable frames

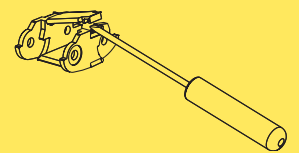
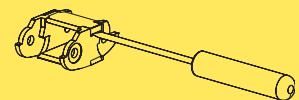

How to open the cover.

Special tool to remove the connecting pivots:  
Part Number PZ010.



For further information please consult Brevetti Stendalto's Technical Office

# Serie Medium

## SR300 Nylon Cable Chain

### Inner height (D) 17 mm

Single link construction with anti-friction single-pin. Not openable. The chain is an extremely strong 18 mm chain, particularly suitable for high frequency/acceleration operations, like on laser cutting heads, in which the chain is highly stressed, due to high acceleration in all 3 directions.

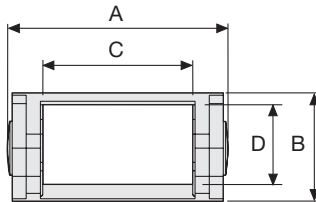

### Pin

Part.no PG300

### Technical characteristics when self-supported

Speed	10 m/s
Acceleration	50 m/s <sup>2</sup>

For higher requirements please consult our technical dept.

A	B	C	D	R	Weight/m	Chain
mm	mm	mm	mm	mm	kg	Part Number
30	23	14	18	040-060-080-120	0,38	SR300015□□□*
41	23	25	18	040-060-080-120	0,43	SR300025□□□*
52	23	36	18	040-060-080-120	0,48	SR300035□□□*

\*Complete the code by inserting the value of the radius (R): Ex. SR300015 □□□□

For sliding applications, technical data can slightly change according to frequency, added weight and environment.

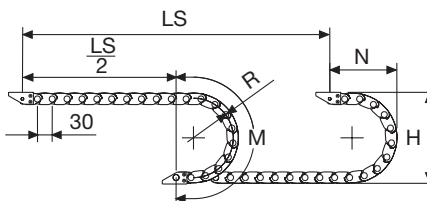

R	H	N	M	N1	M1
mm	mm	mm	mm	mm	mm
40	103	85	185	185	385
60	143	105	248	410	865
80	183	125	315	545	1165
120	263	165	440	750	1640

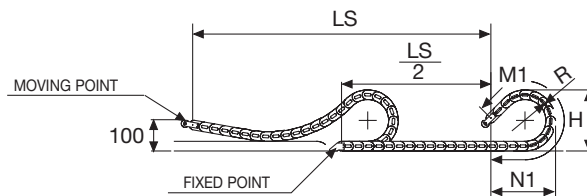

Length of chain (L)  
Half travel distance ( $\frac{LS}{2}$ )  
plus length of curve (M) or (M1)

$$L = \frac{LS}{2} + M \text{ or } M1$$



### Self-Supporting Capacity Diagram

The maximum length of the self-supporting capacity ( $\frac{LS}{2}$ ) in relationship to the weight of the cables and hoses contained per linear metre.

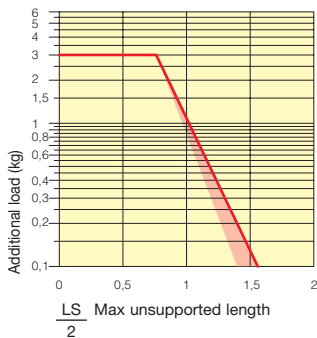

### Bright Zinc Plated Steel End Brackets\*

The end brackets set allows the two ends of the chain to be attached to the equipment.

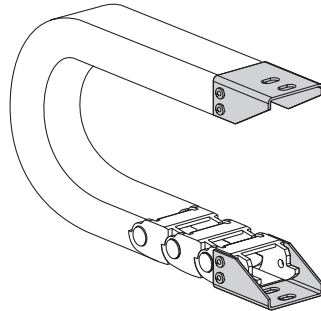
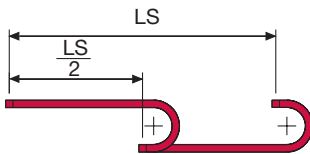
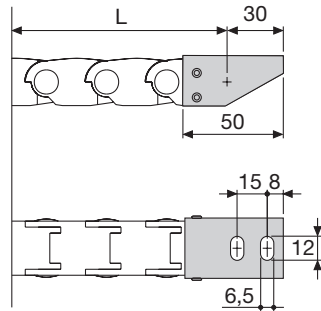

Fig. A  
Chain fixed outside the radius. (Fig A)  
See end brackets mounting variations page 31.



The red marking in the diagram area considers the difference of weight between various widths of chain.



For applications with  $\frac{LS}{2}$  and weights not included in the area of the diagram showing self-supporting capacity, verify the possible use of support rollers (see page 30).

### Bright Zinc Plated Steel Type Part Numbers

Complete Set Assembled	
Chain	End Brackets
Type	Set
SR300015...	AP300KM □**
SR300025...	AG300KM □**
SR300035...	A300035KM □**

Complete Set Unassembled	
Chain	End Brackets
Type	Set
SR300015...	AP300K □**
SR300025...	AG300K □**
SR300035...	A300035K □**

\*Available on request in stainless steel

\*\* 1=Pos.1; 2=Pos.2; 3=Pos.3

See end brackets mounting variations page 31.

Serie Medium

**SR300**  
Nylon Cable Chain

3

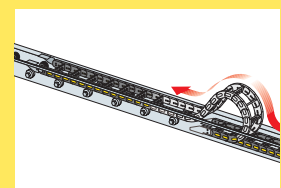

Suitable to long travel distance.  
To choose the guide channel see page 54

Special tool to remove the connecting pivots:  
Part Number PZ010.



For further information please consult Brevetti Stendalto's Technical Office

# Serie Medium

## SR305A Nylon Cable Chain with removable frames

### Inner height (D) 24 mm

Double share single link joining construction with large anti-friction single-pin. Frames removable from inner radius. Vertical separators are available. Wide frames on outer radius offer good protection. Due to its design with double-share lateral side, the chain is very robust, meanwhile offering very low friction.

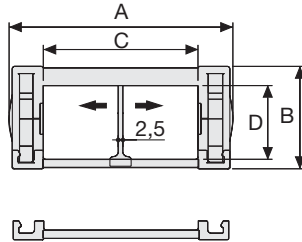

### Separator

- Unassembled	Part.no S305
- Assembled	Part.no S305MC

### Pin

Part.no PG305

### Technical characteristics when self-supported

Speed	10 m/s
Acceleration	50 m/s <sup>2</sup>

For higher requirements please consult our technical dept.

A	B	C	D	R	Weight/m	Chain
mm	mm	mm	mm	mm	kg	Part Number
54	30	30	24	50	0,85	SR305A008
54	30	30	24	70	0,85	SR305A010
54	30	30	24	120	0,85	SR305A020
54	30	30	24	150	0,85	SR305A050
74	30	50	24	50	0,95	SR305A009
74	30	50	24	70	0,95	SR305A030
74	30	50	24	120	0,95	SR305A040
74	30	50	24	150	0,95	SR305A060

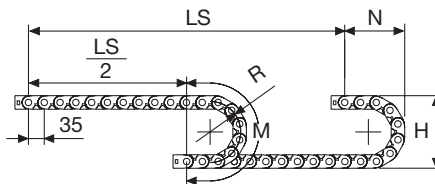

R	H	N	M
mm	mm	mm	mm
50	130	105	230
70	170	120	290
120	270	175	450
150	330	205	545

Length of chain (L)  
Half travel distance ( $\frac{LS}{2}$ )  
plus length of curve (M)

$$L = \frac{LS}{2} + M$$





### Self-Supporting Capacity Diagram

The maximum length of the self-supporting capacity ( $\frac{LS}{2}$ ) in relationship to the weight of the cables and hoses contained per linear metre.

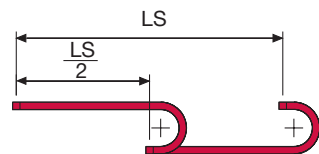
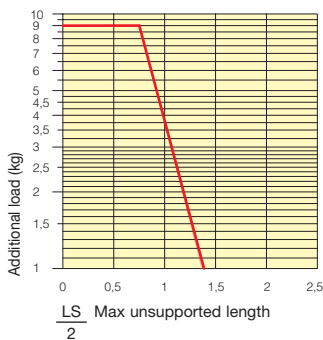

The red marking in the diagram area considers the difference of weight between various widths of chain.

For applications with  $\frac{LS}{2}$  and weights not included in the area of the diagram showing self-supporting capacity, verify the possible use of support rollers (see page 30).

### End Brackets

The end brackets set allows the two ends of the chain to be attached to the equipment.

#### Nylon Type

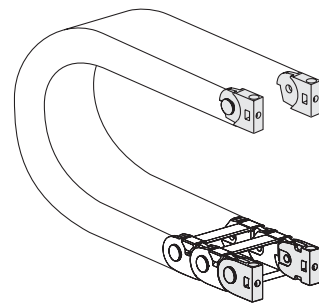

Fig. A  
The chain can be fixed frontally, inner or outer radius. (Fig A)

#### Bright Zinc Plated Steel Type\*

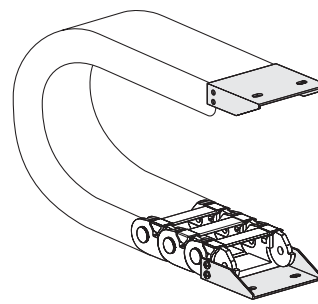
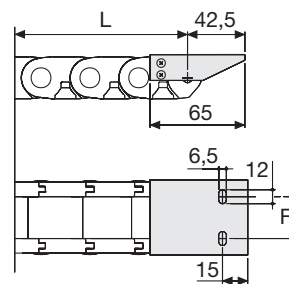
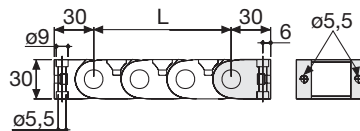

Fig. B  
Chain fixed outside the radius. (Fig B)  
See end brackets mounting variations page 31.



Chain Type	F mm
SR305A C=30	42,5
SR305A C=50	62,5

Chain Type	F mm
SR305A C=30	30,5
SR305A C=50	50,5

### Nylon Type Part Numbers

Complete Set Assembled	
Chain Type	End Brackets Set
SR305A C=30	AN305KM
SR305A C=50	AN305KM

Complete Set Unassembled	
Chain Type	End Brackets Set
SR305A C=30	AN305K
SR305A C=50	AN305K

### Bright Zinc Plated Steel Type Part Numbers

Complete Set Assembled	
Chain Type	End Brackets Set
SR305A C=30	AP305AKM1
SR305A C=50	AG305AKM1

Complete Set Unassembled	
Chain Type	End Brackets Set
SR305A C=30	AP305AK1
SR305A C=50	AG305AK1

\*Available on request in stainless steel

### Serie Medium

## SR305A

Nylon Cable Chain with removable frames

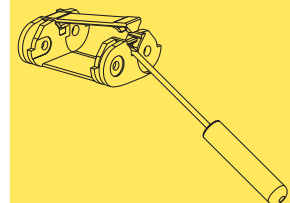
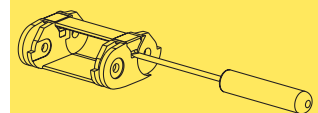

How to open the cover.

Special tool to remove the connecting pivots:  
Part Number PZ010.



For further information please consult Brevetti Stendalto's Technical Office

# Serie Medium

## SR305 Nylon Cable Chain

### Inner height (D) 20 mm

Double share single link joining construction with large anti-friction single-pin. Not openable. Vertical separators are available. Due to its design with double-share lateral side, the chain is very robust, meanwhile offering very low friction. Used with guide channels, this chain is particularly suitable for long distance travel.

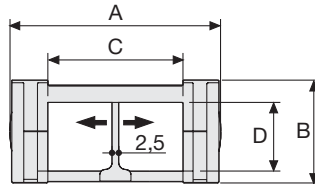

### Separator\*

- Unassembled	Part.no S305
- Assembled	Part.no S305MC

### Pin

Part.no PG305

### Technical characteristics when self-supported

Speed	10 m/s
Acceleration	50 m/s <sup>2</sup>

For higher requirements please consult our technical dept.

For sliding applications, technical data can slightly change according to frequency, added weight and environment.

\*Separator not to be used in long-stroke applications

A	B	C	D	R	Weight/m	Chain Part Number
mm	mm	mm	mm	mm	kg	
54	30	30	20	50	0,90	SR305008
54	30	30	20	70	0,90	SR305010
54	30	30	20	120	0,90	SR305020
54	30	30	20	150	0,90	SR305050
74	30	50	20	50	1,00	SR305009
74	30	50	20	70	1,00	SR305030
74	30	50	20	120	1,00	SR305040
74	30	50	20	150	1,00	SR305060

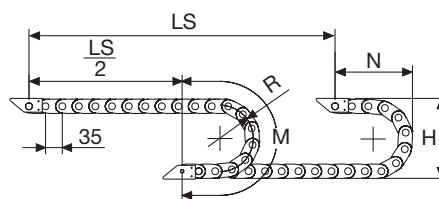

R	H	N	M	N1	M1
mm	mm	mm	mm	mm	mm
50	130	105	230	125	270
70	170	120	290	160	365
120	270	175	450	330	800
150	330	205	545	435	1065

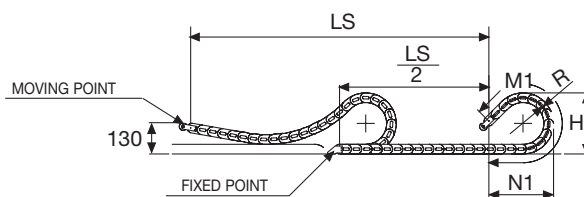

Length of chain (L)  
Half travel distance ( $\frac{LS}{2}$ )  
plus length of curve (M) or (M1)

$$L = \frac{LS}{2} + M \text{ or } M1$$





# Serie Medium

## SR355A Nylon Cable Chain with removable frames

### Inner height (D) 31 mm

Double share single link joining construction with large anti-friction single-pin. Frames removable from inner radius. Vertical separators are available. Wide frames on outer radius offer good protection. Due to its design with double-share lateral side, the chain is very robust, meanwhile offering very low friction.

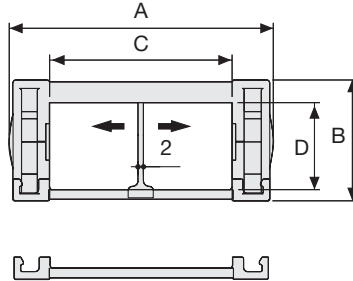

### Separator

- Unassembled	Part.no S355
- Assembled	Part.no S355MC

### Pin

Part.no PG355

### Technical characteristics when self-supported

Speed	10 m/s
Acceleration	50 m/s <sup>2</sup>

For higher requirements please consult our technical dept.

A	B	C	D	R	Weight/m	Chain
mm	mm	mm	mm	mm	kg	Part Number
74	43	45	31	75	1,40	SR355A045
74	43	45	31	100	1,40	SR355A046
74	43	45	31	150	1,40	SR355A047
74	43	45	31	200	1,40	SR355A048
94	43	65	31	75	1,50	SR355A065
94	43	65	31	100	1,50	SR355A066
94	43	65	31	150	1,50	SR355A067
94	43	65	31	200	1,50	SR355A068
124	43	95	31	75	1,70	SR355A095
124	43	95	31	100	1,70	SR355A096
124	43	95	31	150	1,70	SR355A097
124	43	95	31	200	1,70	SR355A098

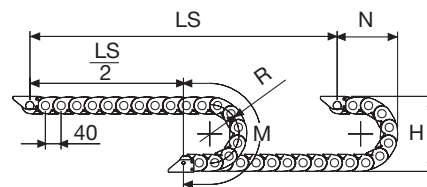

R	H	N	M
mm	mm	mm	mm
75	193	140	315
100	243	165	395
150	343	215	555
200	443	265	710

Length of chain (L)  
Half travel distance ( $\frac{LS}{2}$ )  
plus length of curve (M)

$$L = \frac{LS}{2} + M$$

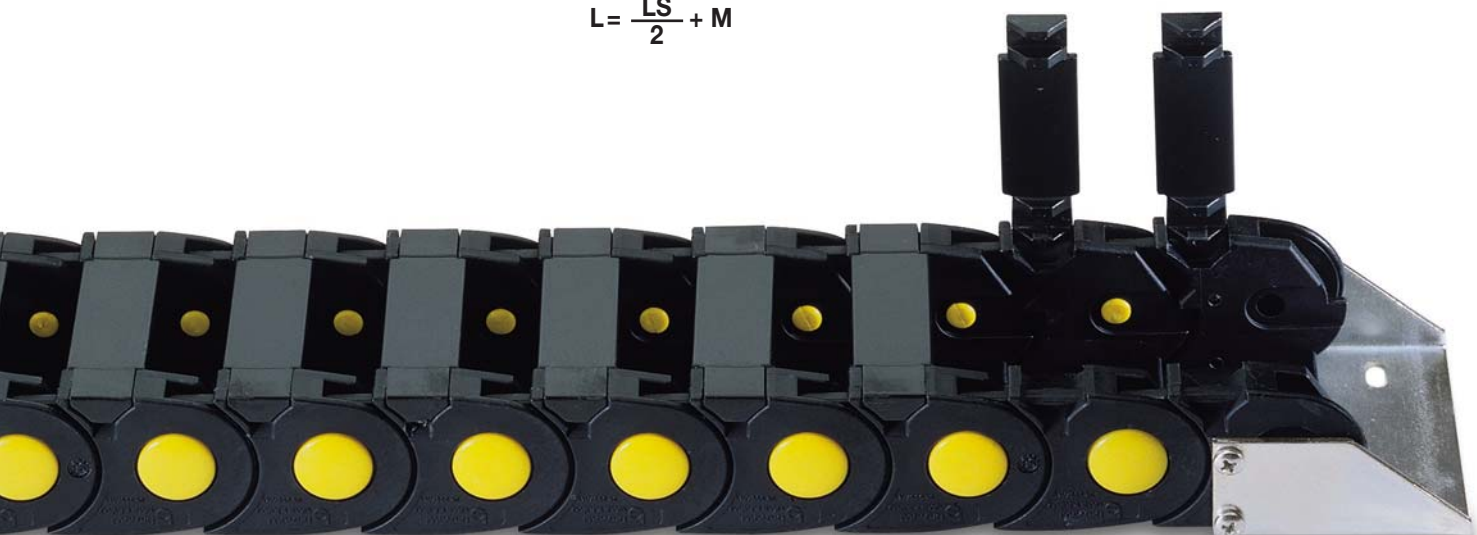

### Self-Supporting Capacity Diagram

The maximum length of the self-supporting capacity ( $\frac{LS}{2}$ ) in relationship to the weight of the cables and hoses contained per linear metre.

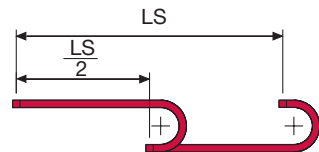
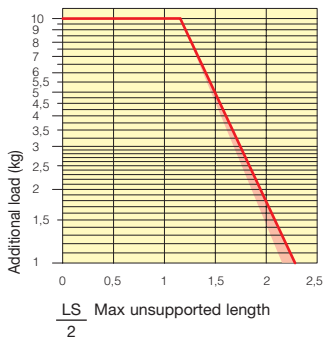

The red marking in the diagram area considers the difference of weight between various widths of chain.

For applications with  $\frac{LS}{2}$  and weights not included in the area of the diagram showing self-supporting capacity, verify the possible use of support rollers (see page 30).

### End Brackets

The end brackets set allows the two ends of the chain to be attached to the equipment.

#### Nylon Type

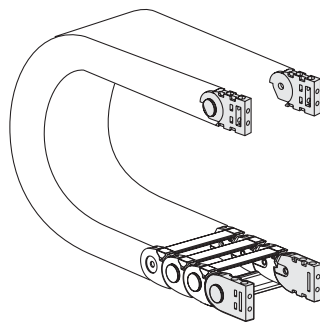

Fig. A  
The chain can be fixed frontally, inner or outer radius. (Fig A)

#### Bright Zinc Plated Steel Type\*

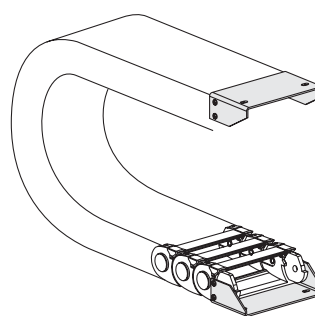
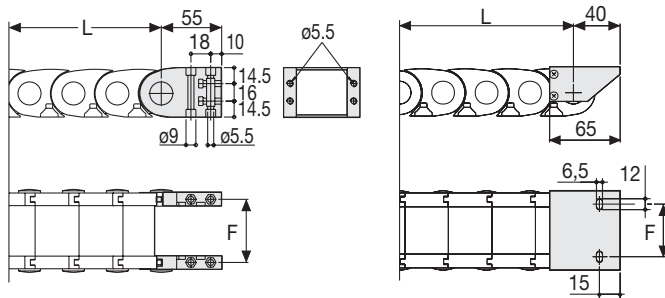

Fig. B  
Chain fixed outside the radius. (Fig B)  
See end brackets mounting variations on page 31.



Chain Type	F mm
SR355A C=45	59
SR355A C=65	79
SR355A C=95	109

Chain Type	F mm
SR355A C=45	50
SR355A C=65	70
SR355A C=95	100

#### Nylon Type Part Numbers

Complete Set Assembled	
Chain	End Brackets
Type	Set
SR355A C=45	AN355KM
SR355A C=65	AN355KM
SR355A C=95	AN355KM

Complete Set Unassembled	
Chain	End Brackets
Type	Set
SR355A C=45	AN355K
SR355A C=65	AN355K
SR355A C=95	AN355K

#### Bright Zinc Plated Steel Type Part Numbers

Complete Set Assembled	
Chain	End Brackets
Type	Set
SR355A C=45	AP355AKM1
SR355A C=65	AM355AKM1
SR355A C=95	AG355AKM1

Complete Set Unassembled	
Chain	End Brackets
Type	Set
SR355A C=45	AP355AK1
SR355A C=65	AM355AK1
SR355A C=95	AG355AK1

\*Available on request in stainless steel

### Serie Medium

## SR355A

Nylon Cable Chain  
with removable frames

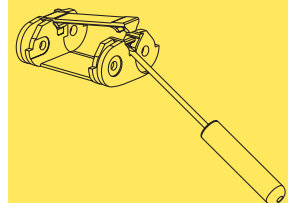
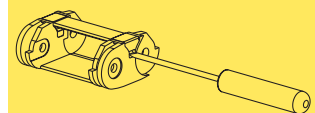

How to open the cover.

Special tool to remove the connecting pivots:  
Part Number PZ010.



For further information please consult Brevetti Stendalto's Technical Office

# Serie Medium

## SR355 Nylon Cable Chain

### Inner height (D) 30 mm

Double share single link joining construction with large anti-friction single-pin. Not openable. Vertical separators are available. Due to its design with double-share lateral side, the chain is very robust, meanwhile offering very low friction. Used with guide channels, this chain is particularly suitable for long distance travel.

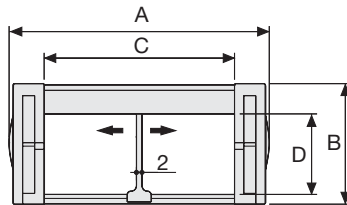

### Separator\*

- Unassembled	Part.no S355
- Assembled	Part.no S355MC

### Pin

Part.no PG355

### Technical characteristics when self-supported

Speed	10 m/s
Acceleration	50 m/s <sup>2</sup>

For higher requirements please consult our technical dept.

For sliding applications, technical data can slightly change according to frequency, added weight and environment.

\*Separator not to be used in long-stroke applications

A	B	C	D	R	Weight/m	Chain Part Number
mm	mm	mm	mm	mm	kg	
74	45	45	30	75	1,35	SR355045
74	45	45	30	100	1,35	SR355046
74	45	45	30	150	1,35	SR355047
74	45	45	30	200	1,35	SR355048
94	45	65	30	75	1,45	SR355065
94	45	65	30	100	1,45	SR355066
94	45	65	30	150	1,45	SR355067
94	45	65	30	200	1,45	SR355068
124	45	95	30	75	1,65	SR355095
124	45	95	30	100	1,65	SR355096
124	45	95	30	150	1,65	SR355097
124	45	95	30	200	1,65	SR355098

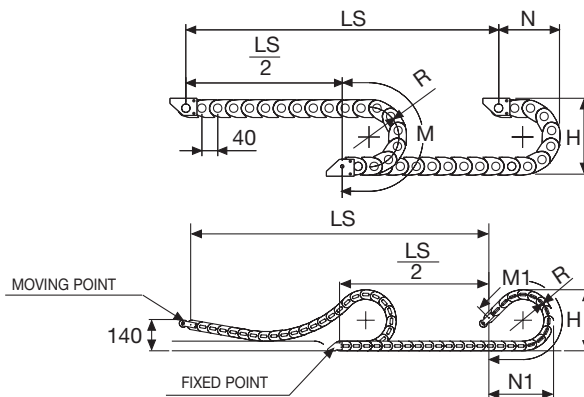

R	H	N	M	N1	M1
mm	mm	mm	mm	mm	mm
75	195	140	315	190	420
100	245	165	395	275	640
150	345	215	555	450	1075
200	445	265	710	620	1515

Length of chain (L)  
 Half travel distance ( $\frac{LS}{2}$ )  
 plus length of curve (M) or (M1)

$$L = \frac{LS}{2} + M \text{ or } M1$$



### Self-Supporting Capacity Diagram

The maximum length of the self-supporting capacity ( $\frac{LS}{2}$ ) in relationship to the weight of the cables and hoses contained per linear metre.

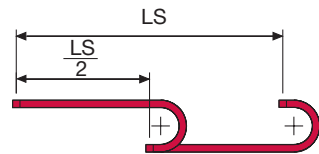
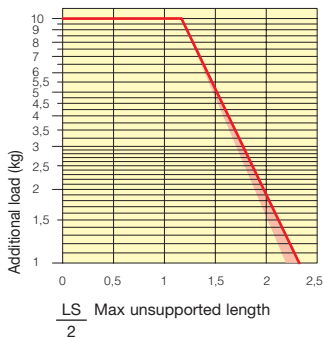

The red marking in the diagram area considers the difference of weight between various widths of chain.

For applications with  $\frac{LS}{2}$  and weights not included in the area of the diagram showing self-supporting capacity, verify the possible use of support rollers (see page 30).

### End Brackets

The end brackets set allows the two ends of the chain to be attached to the equipment.

#### Nylon Type

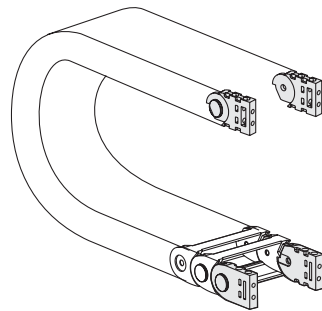

Fig. A  
The chain can be fixed frontally, inner or outer radius. (Fig A)

#### Bright Zinc Plated Steel Type\*

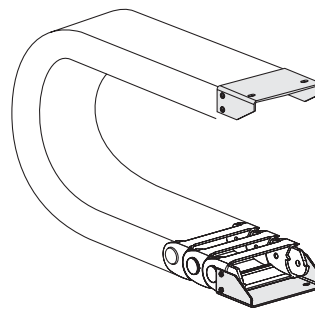
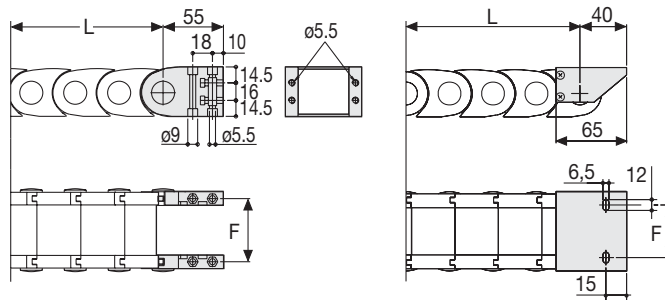

Fig. B  
Chain fixed outside the radius. (Fig B)  
See end brackets mounting variations page 31.



Chain Type	F mm
SR355 C=45	57
SR355 C=65	77
SR355 C=95	107

Chain Type	F mm
SR355 C=45	50
SR355 C=65	70
SR355 C=95	100

### Nylon Type Part Numbers

Complete Set Assembled	
Chain Type	End Brackets Set
SR355 C=45	AN355KM
SR355 C=65	AN355KM
SR355 C=95	AN355KM

Complete Set Unassembled	
Chain Type	End Brackets Set
SR355 C=45	AN355K
SR355 C=65	AN355K
SR355 C=95	AN355K

### Bright Zinc Plated Steel Type Part Numbers

Complete Set Assembled	
Chain Type	End Brackets Set
SR355 C=45	AP355KM□**
SR355 C=65	AM355KM□**
SR355 C=95	AG355KM□**

Complete Set Unassembled	
Chain Type	End Brackets Set
SR355 C=45	AP355K□**
SR355 C=65	AM355K□**
SR355 C=95	AG355K□**

\*Available on request in stainless steel  
\*\* 1=Pos.1; 2=Pos.2; 3=Pos.3  
See end brackets mounting variations page 31.

### Serie Medium

## SR355 Nylon Cable Chain

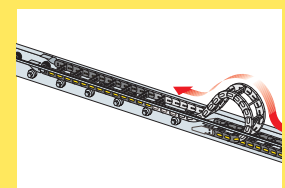

Suitable to long travel distance.  
To choose the guide channel see page 84

Special tool to remove the connecting pivots:  
Part Number PZ010.



For further information please consult Brevetti Stendalto's Technical Office

# Serie Medium

## SR400 Nylon Cable Chain with removable frames

### Inner height (D) 25 mm

Double share singlelink joining construction with large anti-friction single-pin. Frames removable from inner radius. Vertical separators are available. Wide frames on outer radius offer good protection. Due to its design with double-share lateral side, the chain is very robust, meanwhile offering very low friction.

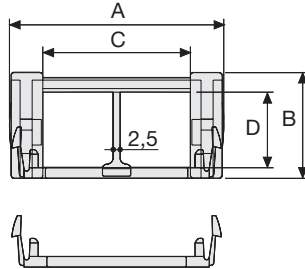

### Separator

- Unassembled	Part.no S400
- Assembled	Part.no S400MC

### Pin

Part.no PG305

### Technical characteristics when self-supported

Speed	10 m/s
Acceleration	50 m/s <sup>2</sup>

For higher requirements please consult our technical dept.

A	B	C	D	R	Weight/m	Chain
mm	mm	mm	mm	mm	kg	Part Number
62	35	40	25	50	1,10	SR400040
62	35	40	25	75	1,10	SR400041
62	35	40	25	100	1,10	SR400042
62	35	40	25	150	1,10	SR400043
82	35	60	25	50	1,25	SR400060
82	35	60	25	75	1,25	SR400061
82	35	60	25	100	1,25	SR400062
82	35	60	25	150	1,25	SR400063

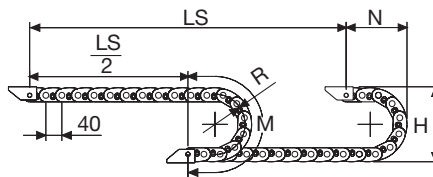

R	H	N	M
mm	mm	mm	mm
50	135	110	240
75	185	135	315
100	235	160	395
150	335	210	555

Length of chain (L)

Half travel distance ( $\frac{LS}{2}$ )  
plus length of curve (M)

$$L = \frac{LS}{2} + M$$





### Self-Supporting Capacity Diagram

The maximum length of the self-supporting capacity ( $\frac{LS}{2}$ ) in relationship to the weight of the cables and hoses contained per linear metre.

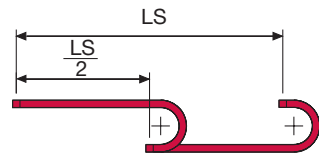
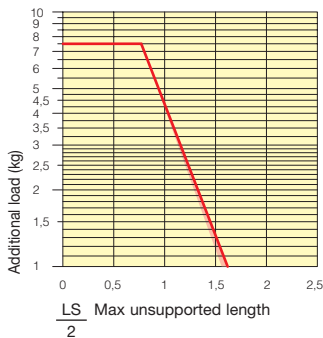

The red marking in the diagram area considers the difference of weight between various widths of chain.

For applications with  $\frac{LS}{2}$  and weights not included in the area of the diagram showing self-supporting capacity, verify the possible use of support rollers (see page 30).

### End Brackets

The end brackets set allows the two ends of the chain to be attached to the equipment.

#### Nylon Type

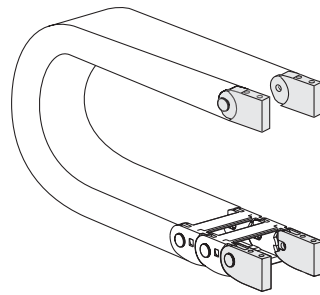

Fig. A  
Chain fixed outside/inside the radius. (Fig A)

#### Bright Zinc Plated Steel Type\*

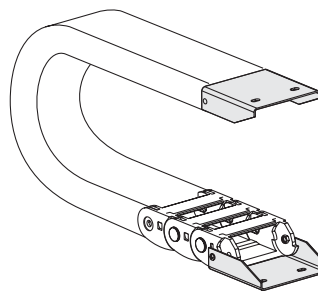
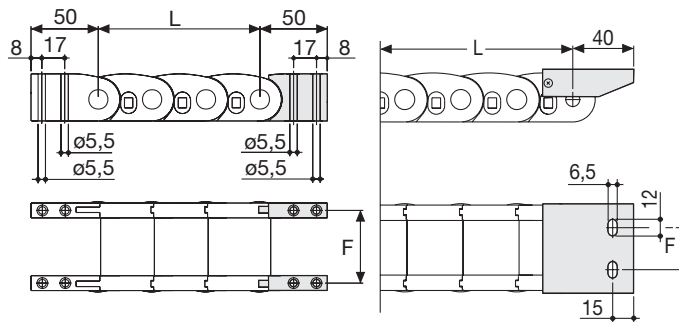

Fig. B  
Chain fixed outside the radius. (Fig B)  
See end brackets mounting variations page 31.



Chain Type	F mm
SR400 C=40	50
SR400 C=60	70

Chain Type	F mm
SR400 C=40	30
SR400 C=60	50

### Nylon Type Part Numbers

Complete Set Assembled	
Chain	End Brackets
Type	Set
SR400 C=40	AN400KM
SR400 C=60	AN400KM

Complete Set Unassembled	
Chain	End Brackets
Type	Set
SR400 C=40	AN400K
SR400 C=60	AN400K

### Bright Zinc Plated Steel Type Part Numbers

Complete Set Assembled	
Chain	End Brackets
Type	Set
SR400 C=40	AP400KM1
SR400 C=60	AG400KM1

Complete Set Unassembled	
Chain	End Brackets
Type	Set
SR400 C=40	AP400K1
SR400 C=60	AG400K1

\* Available on request in stainless steel

### Serie Medium

## SR400

Nylon Cable Chain with removable frames

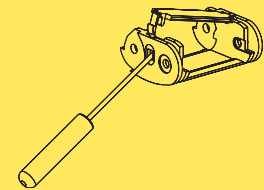
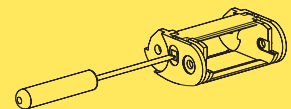

How to open the cover.

Special tool to remove the connecting pivots:  
Part Number PZ010.



For further information please consult Brevetti Stendalto's Technical Office

# Serie Medium

# SR435MI/SR435ME

## Nylon Cable Chain with openable frames

### Inner height (D) 35 mm

Sideband & Frame construction with large anti-friction single-pin.

Frames openable from inner radius (SR435MI) or from outer radius (SR435ME).

Vertical separators are available.

This standard 35 mm chain offers very high load capacities, despite its compact construction.

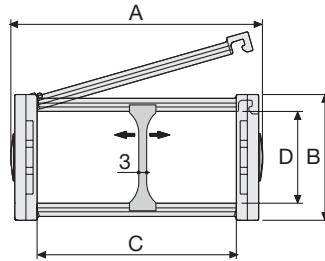

### Separator

- Unassembled	Part.no S4353
- Assembled	Part.no S4353MC

### Pin

Part.no PG4353

### Technical characteristics when self-supported

Speed	10 m/s
Acceleration	50 m/s <sup>2</sup>

For higher requirements please consult our technical dept.

For sliding applications, technical data can slightly change according to frequency, added weight and environment.

A	B	C	D	R	Weight/m	Chain
mm	mm	mm	mm	mm	kg	Part Number
60	49	40	35	060-075-100-125-150-200	1,10	SR435MI(ME)040□□□*
70	49	50	35	060-075-100-125-150-200	1,15	SR435MI(ME)050□□□*
80	49	60	35	060-075-100-125-150-200	1,20	SR435MI(ME)060□□□*
96	49	76	35	060-075-100-125-150-200	1,30	SR435MI(ME)076□□□*
123	49	103	35	060-075-100-125-150-200	1,45	SR435MI(ME)103□□□*
145	49	125	35	060-075-100-125-150-200	1,55	SR435MI(ME)125□□□*
170	49	150	35	060-075-100-125-150-200	1,70	SR435MI(ME)150□□□*

\*Complete the code by inserting the value of the radius (R): Ex. SR435MI(ME)040 □ □ □ □

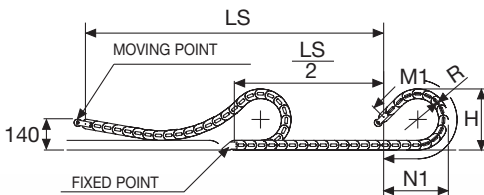
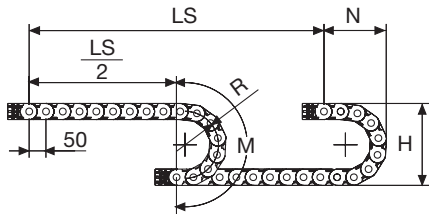

Length of chain (L)

Half travel distance ( $\frac{LS}{2}$ )

plus length of curve (M) or (M1)

$$L = \frac{LS}{2} + M \text{ or } M1$$

R	H	N	M	N1	M1
mm	mm	mm	mm	mm	mm
060	169	135	290	165	345
075	199	155	340	190	420
100	249	175	415	230	530
125	299	200	495	320	750
150	349	230	575	405	970
200	449	275	730	580	1405



### Self-Supporting Capacity Diagram

The maximum length of the self-supporting capacity ( $\frac{LS}{2}$ ) in relationship to the weight of the cables and hoses contained per linear metre.

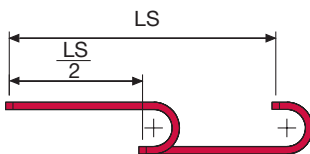
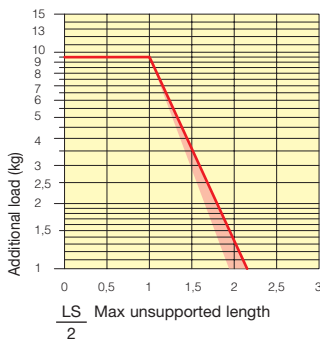

The red marking in the diagram area considers the difference of weight between various widths of chain.

For applications with  $\frac{LS}{2}$  and weights not included in the area of the diagram showing self-supporting capacity, verify the possible use of support rollers (see page 30).

### End Brackets

The end brackets set allows the two ends of the chain to be attached to the equipment. Set complete with tiewrap clamps available on request.

#### Nylon Type

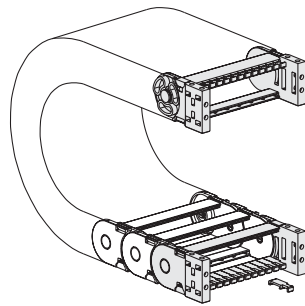
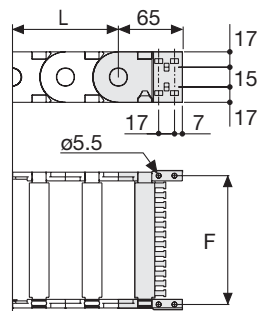

Fig. A  
The chain can be fixed frontally, inner or outer radius. (Fig A)



Chain Type	F mm
SR435MI(ME)040	51
SR435MI(ME)050	61
SR435MI(ME)060	71
SR435MI(ME)076	87
SR435MI(ME)103	114
SR435MI(ME)125	136
SR435MI(ME)150	161

#### Nylon Type Part Numbers

Complete Set Assembled Chain Type	End Brackets Set
SR435...	AN435M□□□*KM

Complete Set Unassembled Chain Type	End Brackets Set
SR435...	AN435M□□□*K

#### Tiewrap Clamp

Part Number
Assembl. SFC435M□□□*KM
Unassembl. SFC435M□□□*K

\* Complete the code by inserting the value of the quote C.

#### Bright Zinc Plated Steel Type\*

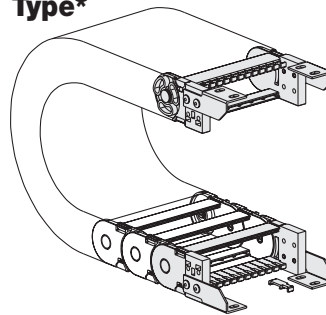
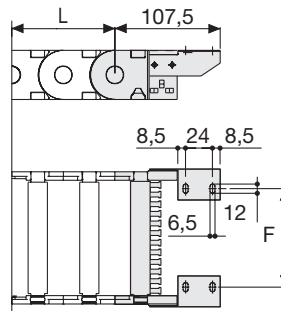

Fig. B  
Chain fixed outside the radius. (Fig B)  
See end brackets mounting variations page 31.



Chain Type	F mm
SR435MI(ME)040	30
SR435MI(ME)050	40
SR435MI(ME)060	50
SR435MI(ME)076	66
SR435MI(ME)103	93
SR435MI(ME)125	115
SR435MI(ME)150	140

#### Bright Zinc Plated Steel Type Part Numbers

Complete Set Assembled Chain Type	End Brackets Set
SR435...	A435M□□□KM□**

Complete Set Unassembled Chain Type	End Brackets Set
SR435...	A435M□□□K□**

\*Available on request in stainless steel  
\*\* 1=Pos.1; 2=Pos.2; 3=Pos.3  
See end brackets mounting variations page 31.

### Serie Medium

## SR435MI

## SR435ME

Nylon Cable Chain with openable frames

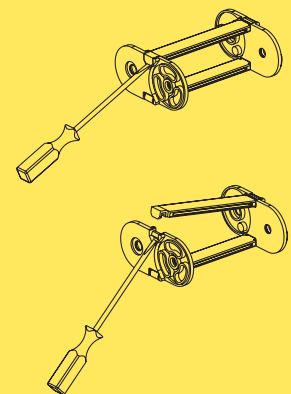

How to open the cover.

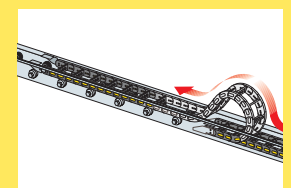

Suitable to long travel distance.  
To choose the guide channel see page 84

Special tool to remove the connecting pivots:  
Part Number PZ010.



For further information please consult Brevetti Stendalto's Technical Office

# Serie Medium

## SR445MI/SR445ME Nylon Cable Chain with openable frames

### Inner height (D) 45 mm

Sideband & Frame construction with large anti-friction single-pin. Frames openable from inner radius (SR445MI) or from outer radius (SR445ME). Vertical and horizontal modular separator system is available. This standard 45mm chain offers very high load capacities, despite its compact construction.

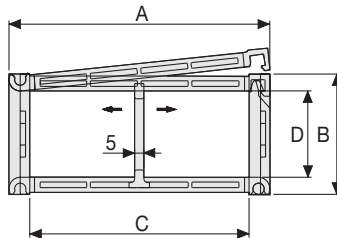

### Separator

- Unassembled Part.no S445
- Assembled Part.no S445MC

### Strong-hold separator

for C > 200 mm

- Unassembled Part.no S445SH
- Assembled Part.no S445SHMC

### Pin

Part.no PG445

### Technical characteristics when self-supported

Speed	10 m/s
Acceleration	50 m/s <sup>2</sup>

For higher requirements please consult our technical dept.

For sliding applications, technical data can slightly change according to frequency, added weight and environment.

A	B	C	D	R	Weight/m	Chain
mm	mm	mm	mm	mm	kg	Part Number
72	64	50	45	075-100-125-150-200-250-300	1,64	SR445MI(ME)050□□□*
83	64	61	45	075-100-125-150-200-250-300	1,64	SR445MI(ME)061□□□*
97	64	75	45	075-100-125-150-200-250-300	1,76	SR445MI(ME)075□□□*
103	64	81	45	075-100-125-150-200-250-300	1,79	SR445MI(ME)081□□□*
117	64	95	45	075-100-125-150-200-250-300	1,86	SR445MI(ME)095□□□*
122	64	100	45	075-100-125-150-200-250-300	1,87	SR445MI(ME)100□□□*
129	64	107	45	075-100-125-150-200-250-300	1,90	SR445MI(ME)107□□□*
139	64	117	45	075-100-125-150-200-250-300	1,93	SR445MI(ME)117□□□*
147	64	125	45	075-100-125-150-200-250-300	2,01	SR445MI(ME)125□□□*
158	64	136	45	075-100-125-150-200-250-300	2,07	SR445MI(ME)136□□□*
172	64	150	45	075-100-125-150-200-250-300	2,13	SR445MI(ME)150□□□*
197	64	175	45	075-100-125-150-200-250-300	2,25	SR445MI(ME)175□□□*
222	64	200	45	075-100-125-150-200-250-300	2,39	SR445MI(ME)200□□□*
233	64	211	45	075-100-125-150-200-250-300	2,44	SR445MI(ME)211□□□*
247	64	225	45	075-100-125-150-200-250-300	2,52	SR445MI(ME)225□□□*
274	64	252	45	075-100-125-150-200-250-300	2,66	SR445MI(ME)252□□□*
283	64	261	45	075-100-125-150-200-250-300	2,70	SR445MI(ME)261□□□*
334	64	312	45	075-100-125-150-200-250-300	3,05	SR445MI(ME)334□□□*
356	64	334	45	075-100-125-150-200-250-300	3,05	SR445MI(ME)334□□□*
384	64	362	45	075-100-125-150-200-250-300	3,18	SR445MI(ME)362□□□*

\*Complete the code by inserting the value of the radius (R): Ex. SR445MI(ME)050 □ □ □ □

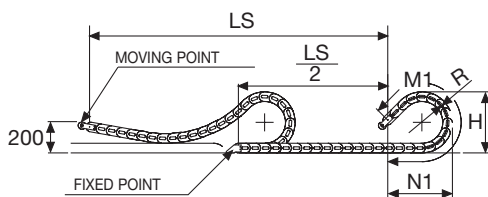
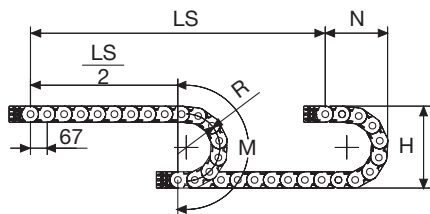

Length of chain (L)

Half travel distance ( $\frac{LS}{2}$ )

plus length of curve (M) or (M1)

$$L = \frac{LS}{2} + M \text{ or } M1$$

R	H	N	M	N1	M1
mm	mm	mm	mm	mm	mm
075	214	180	370	205	425
100	264	200	450	230	505
125	314	225	530	285	655
150	364	250	605	375	875
200	464	300	765	550	1310
250	564	350	920	725	1750
300	664	400	1080	895	2185

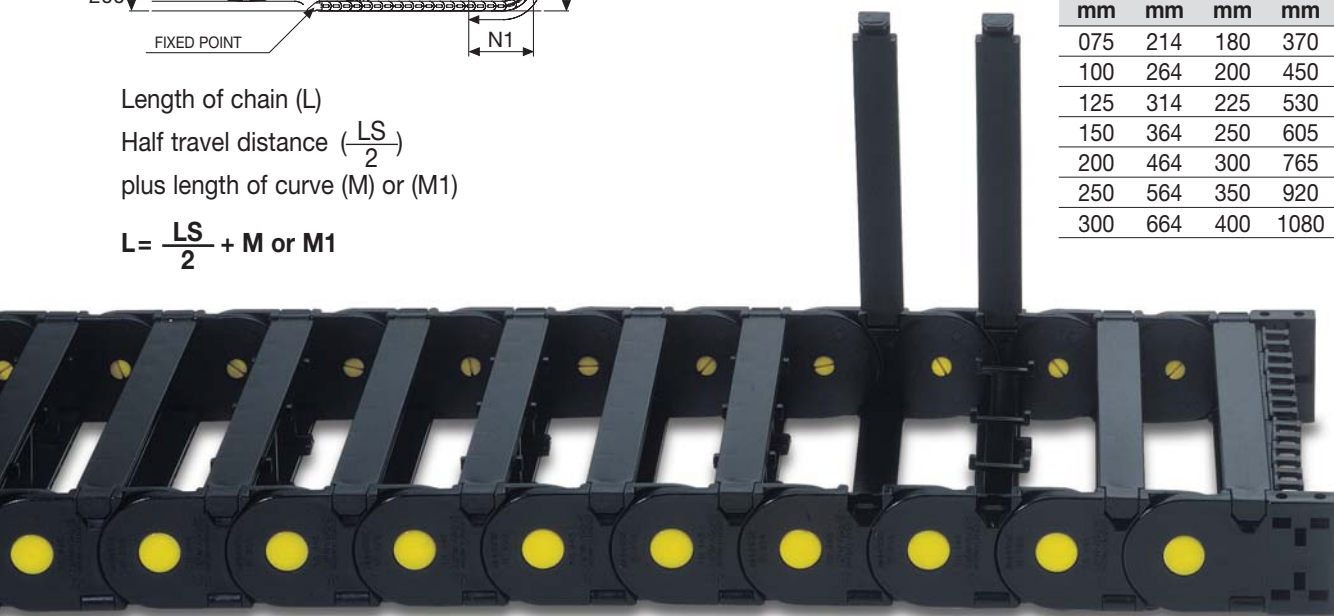

### Self-Supporting Capacity Diagram

The maximum length of the self-supporting capacity ( $\frac{LS}{2}$ ) in relationship to the weight of the cables and hoses contained per linear metre.

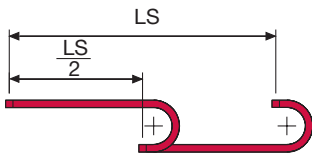
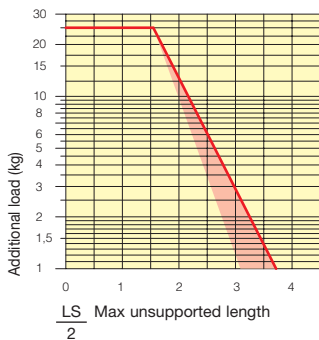

The red marking in the diagram area considers the difference of weight between various widths of chain.

For applications with  $\frac{LS}{2}$  and weights not included in the area of the diagram showing self-supporting capacity, verify the possible use of support rollers (see page 30).

### End Brackets

The end brackets set allows the two ends of the chain to be attached to the equipment. Set complete with tiewrap clamps available on request.

#### Nylon Type

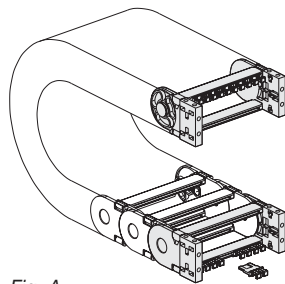
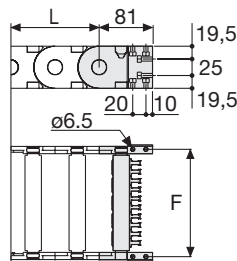

Fig. A  
The chain can be fixed frontally, inner or outer radius. (Fig A)



Chain Type	F mm
SR445MI(ME)050	63
SR445MI(ME)061	74
SR445MI(ME)075	88
SR445MI(ME)081	94
SR445MI(ME)095	108
SR445MI(ME)100	113
SR445MI(ME)107	120
SR445MI(ME)117	130
SR445MI(ME)125	138
SR445MI(ME)136	149
SR445MI(ME)150	163
SR445MI(ME)175	188
SR445MI(ME)200	213
SR445MI(ME)211	224
SR445MI(ME)225	238
SR445MI(ME)252	265
SR445MI(ME)261	274
SR445MI(ME)312	325
SR445MI(ME)334	347
SR445MI(ME)362	375

#### Nylon Type Part Numbers

Complete Set Assembled	
Chain	End Brackets
Type	Set
SR445...	AN445M□□□*KM

Complete Set Unassembled	
Chain	End Brackets
Type	Set
SR445...	AN445M□□□*K

Tiewrap Clamp	
Part Number	
Assembled	SFC445 □□□*KM
Unassembled	SFC445 □□□*K

\* Complete the code by inserting the value of the quote C.

#### Bright Zinc Plated Steel Type\*

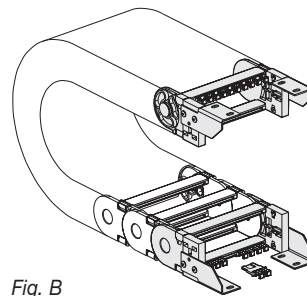
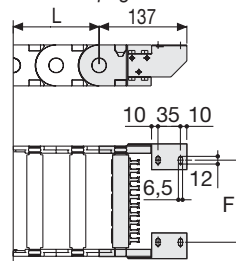

Fig. B  
Chain fixed outside the radius. (Fig B)  
See end brackets mounting variations page 31.



Chain Type	F mm
SR445MI(ME)050	28
SR445MI(ME)061	39
SR445MI(ME)075	53
SR445MI(ME)081	59
SR445MI(ME)095	73
SR445MI(ME)100	78
SR445MI(ME)107	85
SR445MI(ME)117	95
SR445MI(ME)125	103
SR445MI(ME)136	114
SR445MI(ME)150	128
SR445MI(ME)175	153
SR445MI(ME)200	178
SR445MI(ME)211	189
SR445MI(ME)225	203
SR445MI(ME)252	230
SR445MI(ME)261	239
SR445MI(ME)312	290
SR445MI(ME)334	312
SR445MI(ME)362	340

#### Bright Zinc Plated Steel Type Part Numbers

Complete Set Assembled	
Chain	End Brackets
Type	Set
SR445...	A445M□□□KM□**

Complete Set Unassembled	
Chain	End Brackets
Type	Set
SR445...	A445M□□□K□**

\*Available on request in stainless steel  
\*\* 1=Pos.1; 2=Pos.2; 3=Pos.3  
See end brackets mounting variations page 31.

### Serie Medium

## SR445MI SR445ME

Nylon Cable Chain  
with openable frames

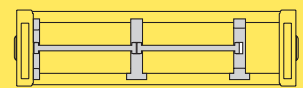

Separation System  
To choose the separators see page. 176

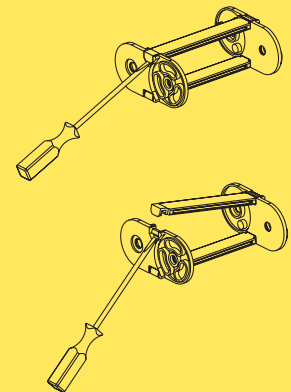

How to open the cover.

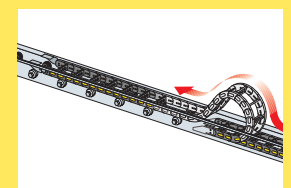

Suitable to long travel distance.  
To choose the guide channel see page 160

Special tool to remove the connecting pivots:  
Part Number PZ010.



For further information please consult Brevetti Stendalto's Technical Office

# Serie Medium

## SR660A Nylon Cable Chain with openable frames

### Inner height (D) 37 mm

Double share Sideband & Frame construction with large anti-friction single-pin. Frames openable from inner radius. As standard the chain comes with frames every second link, on request with frames every link. Vertical and horizontal modular separator system is available.

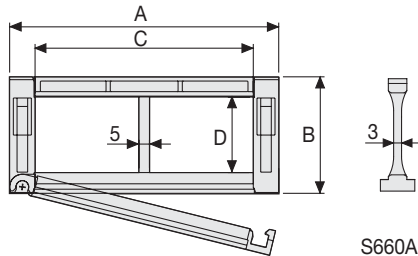

### Separator

- Unassembled Part.no S660A
- Assembled Part.no S660AMC

### Strong-hold separator

for C > 200 mm

- Unassembled Part.no S660AH
- Assembled Part.no S660AHMC

### Pin

Part.no PG660

### Technical characteristics when self-supported

Speed	6 m/s
Acceleration	30 m/s <sup>2</sup>

For higher requirements please consult our technical dept.

For sliding applications, technical data can slightly change according to frequency, added weight and environment.

A	B	C	D	R	Weight/m	Chain
mm	mm	mm	mm	mm	kg	Part Number
75	55	50	37	100-150-200-250	1,51	SR660A050□□□*
86	55	61	37	100-150-200-250	1,51	SR660A061□□□*
100	55	75	37	100-150-200-250	1,59	SR660A075□□□*
106	55	81	37	100-150-200-250	1,61	SR660A081□□□*
120	55	95	37	100-150-200-250	1,66	SR660A095□□□*
125	55	100	37	100-150-200-250	1,66	SR660A100□□□*
132	55	107	37	100-150-200-250	1,69	SR660A107□□□*
142	55	117	37	100-150-200-250	1,71	SR660A117□□□*
150	55	125	37	100-150-200-250	1,76	SR660A125□□□*
161	55	136	37	100-150-200-250	1,80	SR660A136□□□*
175	55	150	37	100-150-200-250	1,84	SR660A150□□□*
200	55	175	37	100-150-200-250	1,93	SR660A175□□□*
225	55	200	37	100-150-200-250	2,02	SR660A200□□□*
236	55	211	37	100-150-200-250	2,06	SR660A211□□□*
250	55	225	37	100-150-200-250	2,11	SR660A225□□□*
277	55	252	37	100-150-200-250	2,21	SR660A252□□□*
286	55	261	37	100-150-200-250	2,24	SR660A261□□□*
337	55	312	37	100-150-200-250	2,43	SR660A312□□□*
359	55	334	37	100-150-200-250	2,52	SR660A334□□□*
387	55	362	37	100-150-200-250	2,61	SR660A362□□□*

\*Complete the code by inserting the value of the radius (R): Ex. SR660A050 □ □ □ □ □

Chain equipped with nylon frame every pitch: complete the code by inserting the letter D.

Ex. SR660A050150 □

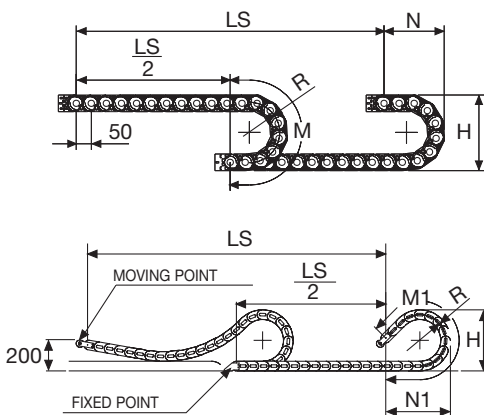

Length of chain (L)

Half travel distance ( $\frac{LS}{2}$ )

plus length of curve (M) or (M1)

$$L = \frac{LS}{2} + M \text{ or } M1$$

R	H	N	M	N1	M1
mm	mm	mm	mm	mm	mm
100	255	180	415	205	470
150	355	230	575	360	855
200	455	280	730	535	1290
250	555	330	885	705	1730

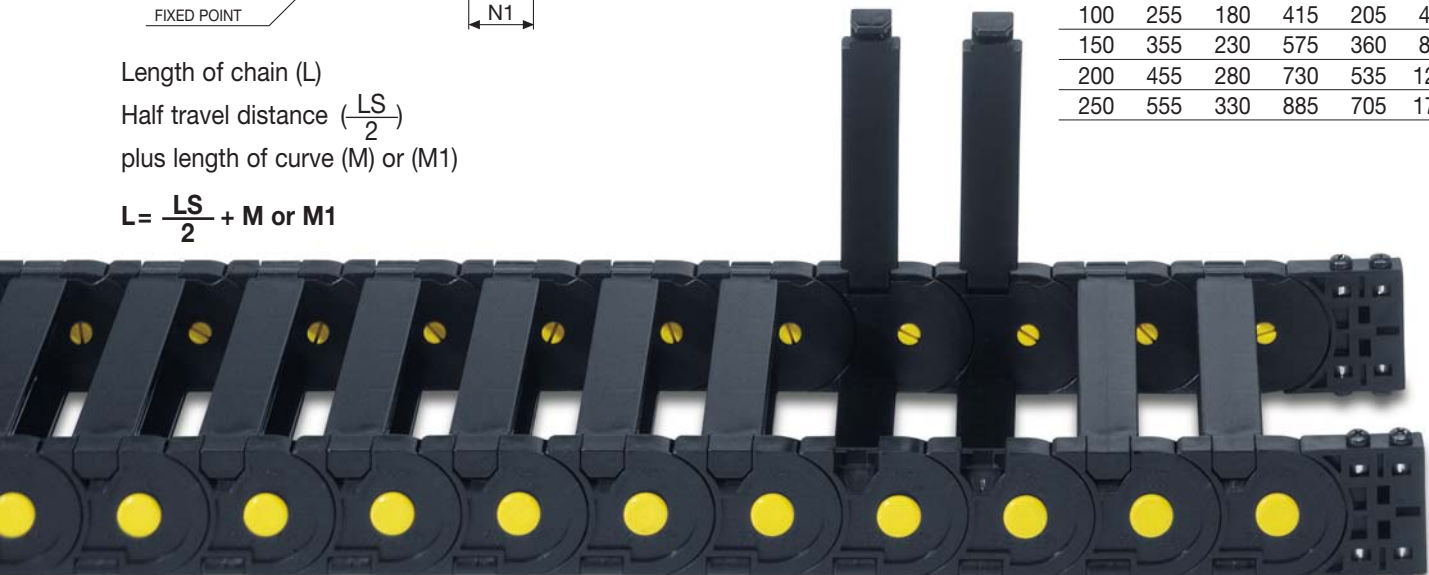

### Self-Supporting Capacity Diagram

The maximum length of the self-supporting capacity ( $\frac{LS}{2}$ ) in relationship to the weight of the cables and hoses contained per linear metre.

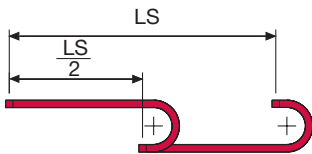
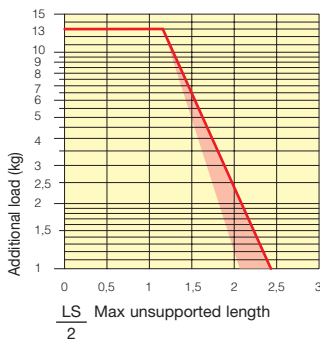

The red marking in the diagram area considers the difference of weight between various widths of chains assembled with nylon frames every second pitch.

For applications with  $\frac{LS}{2}$  and weights not included in the area of the diagram showing self-supporting capacity, verify the possible use of support rollers (see page 30).

### End Brackets

The end brackets set allows the two ends of the chain to be attached to the equipment.

#### Nylon Type

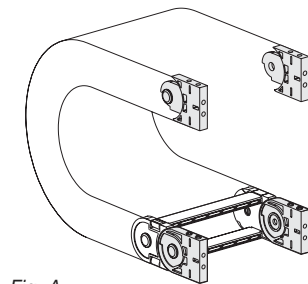
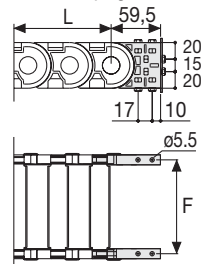

Fig. A  
The chain can be fixed frontally, inner or outer radius. (Fig A) See end brackets mounting variations page 31.



Chain Type	F mm
SR660A050	61
SR660A061	72
SR660A075	86
SR660A081	92
SR660A095	106
SR660A100	111
SR660A107	118
SR660A117	128
SR660A125	136
SR660A136	147
SR660A150	161
SR660A175	186
SR660A200	211
SR660A211	222
SR660A225	236
SR660A252	263
SR660A261	272
SR660A312	323
SR660A334	345
SR660A362	373

#### Nylon Type Part Numbers

Complete Set Assembled	
Chain	End Brackets
Type	Set
SR660A...	AN660AKM

Complete Set Unassembled	
Chain	End Brackets
Type	Set
SR660A...	AN660AK

Tiewrap Clamp	
Chain	Tiewrap Clamp
Type	Part Number
SR660A...	SFC660A □□□*

\* Complete the code by inserting the value of the quote C.

#### Bright Zinc Plated Steel Type\*

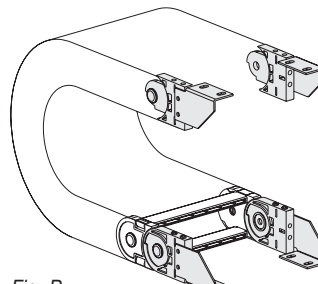
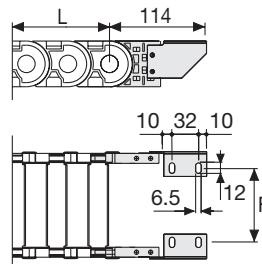

Fig. B  
Chain fixed outside the radius. (Fig B) See end brackets mounting variations page 31.



Chain Type	F mm
SR660A050	38
SR660A061	49
SR660A075	63
SR660A081	69
SR660A095	83
SR660A100	88
SR660A107	95
SR660A117	105
SR660A125	113
SR660A136	124
SR660A150	138
SR660A175	163
SR660A200	188
SR660A211	199
SR660A225	213
SR660A252	240
SR660A261	249
SR660A312	300
SR660A334	333
SR660A362	350

#### Bright Zinc Plated Steel Type Part Numbers

Complete Set Assembled	
Chain	End Brackets
Type	Set
SR660A...	A660AKM □**

Complete Set Unassembled	
Chain	End Brackets
Type	Set
SR660A...	A660AK □**

\*Available on request in stainless steel

\*\* 1=Pos.1; 2=Pos.2; 3=Pos.3

See end brackets mounting variations page 31

### Serie Medium

## SR660A

Nylon Cable Chain with openable frames

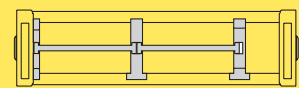

Separation System  
To choose the separators see page. 176

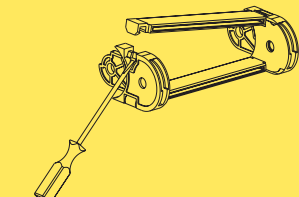

How to open the cover.

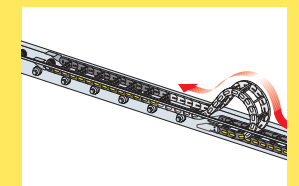

Suitable to long travel distance in frame every pitch version. To choose the guide channel see page 160

Special tool to remove the connecting pivots: Part Number PZ010.



For further information please consult Brevetti Stendalto's Technical Office

# Serie Medium

## SR770A Nylon Cable Chain with openable frames

### Inner height (D) 60 mm

Double share Sideband & Frame construction with large anti-friction single-pin. Frames openable from inner radius. As standard the chain comes with frames every second link, on request with frames every link. Vertical and horizontal modular separator system is available.

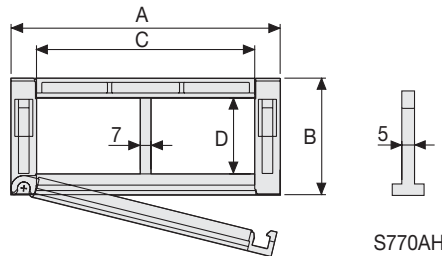

### Separator

- Unassembled Part.no S770A
- Assembled Part.no S770AMC

### Strong-hold separator

for C > 200 mm

- Unassembled Part.no S770AH
- Assembled Part.no S770AHMC

### Pin

Part.no PG770

### Technical characteristics when self-supported

Speed	6 m/s
Acceleration	30 m/s <sup>2</sup>

For higher requirements please consult our technical dept.

For sliding applications, technical data can slightly change according to frequency, added weight and environment.

A	B	C	D	R	Weight/m	Chain
mm	mm	mm	mm	mm	kg	Part Number
80	78	45	60	150-200-250-300	2,25	SR770A045□□□*
91	78	56	60	150-200-250-300	2,25	SR770A056□□□*
105	78	70	60	150-200-250-300	2,31	SR770A070□□□*
111	78	76	60	150-200-250-300	2,32	SR770A076□□□*
125	78	90	60	150-200-250-300	2,36	SR770A090□□□*
130	78	95	60	150-200-250-300	2,36	SR770A095□□□*
137	78	102	60	150-200-250-300	2,38	SR770A102□□□*
147	78	112	60	150-200-250-300	2,39	SR770A112□□□*
155	78	120	60	150-200-250-300	2,43	SR770A120□□□*
166	78	131	60	150-200-250-300	2,46	SR770A131□□□*
180	78	145	60	150-200-250-300	2,49	SR770A145□□□*
205	78	170	60	150-200-250-300	2,55	SR770A170□□□*
230	78	195	60	150-200-250-300	2,62	SR770A195□□□*
241	78	206	60	150-200-250-300	2,65	SR770A206□□□*
255	78	220	60	150-200-250-300	2,68	SR770A220□□□*
282	78	247	60	150-200-250-300	2,75	SR770A247□□□*
291	78	256	60	150-200-250-300	2,77	SR770A256□□□*
342	78	307	60	150-200-250-300	2,88	SR770A307□□□*
364	78	329	60	150-200-250-300	2,94	SR770A329□□□*
392	78	357	60	150-200-250-300	3,01	SR770A357□□□*

\*Complete the code by inserting the value of the radius (R): Ex. SR770A045 □ □ □ □ □

Chain equipped with nylon frame every pitch: complete the code by inserting the letter D.

Ex. SR770A045150 □ □

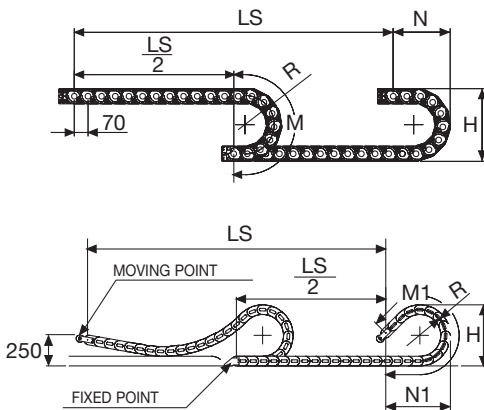

Length of chain (L)

Half travel distance ( $\frac{LS}{2}$ )

plus length of curve (M) or (M1)

$$L = \frac{LS}{2} + M \text{ or } M1$$

R	H	N	M	N1	M1
mm	mm	mm	mm	mm	mm
150	378	260	615	340	785
200	478	310	770	515	1220
250	578	365	930	690	1660
300	678	410	1085	865	2095







# Serie Medium

## SR475MI/SR475ME Nylon Cable Chain with openable frames

### Inner height (D) 75,5 mm

Sideband & Frame construction with large anti-friction single-pin. Frames are openable from inner radius (SR475MI) or from outer radius (SR475ME). Vertical and horizontal modular separator system is available.

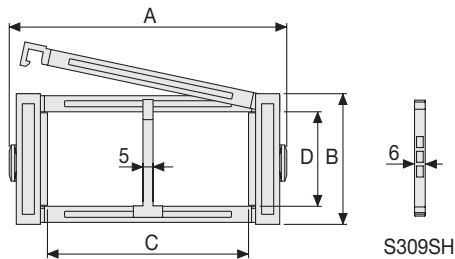

### Separator

- Unassembled Part.no S309S
- Assembled Part.no S309SMC

### Strong-hold separator

for C > 250 mm

- Unassembled Part.no S309SH
- Assembled Part.no S309SHMC

### Pin

Part.no PG475

### Technical characteristics when self-supported

Speed	8 m/s
Acceleration	40 m/s <sup>2</sup>

For higher requirements please consult our technical dept.

For sliding applications, technical data can slightly change according to frequency, added weight and environment.

A	B	C	D	R	Weight/m	Chain
mm	mm	mm	mm	mm	kg	Part Number
112	100,5	74	75,5	150-180-200-250-300-350-400	3,70	SR475MI(ME)074□□□*
132	100,5	94	75,5	150-180-200-250-300-350-400	3,80	SR475MI(ME)094□□□*
157	100,5	119	75,5	150-180-200-250-300-350-400	3,85	SR475MI(ME)119□□□*
164	100,5	126	75,5	150-180-200-250-300-350-400	3,90	SR475MI(ME)126□□□*
187	100,5	149	75,5	150-180-200-250-300-350-400	3,95	SR475MI(ME)149□□□*
227	100,5	189	75,5	150-180-200-250-300-350-400	4,05	SR475MI(ME)189□□□*
262	100,5	224	75,5	150-180-200-250-300-350-400	4,15	SR475MI(ME)224□□□*
288	100,5	250	75,5	150-180-200-250-300-350-400	4,25	SR475MI(ME)250□□□*
312	100,5	274	75,5	150-180-200-250-300-350-400	4,30	SR475MI(ME)274□□□*
338	100,5	300	75,5	150-180-200-250-300-350-400	4,37	SR475MI(ME)300□□□*
362	100,5	324	75,5	150-180-200-250-300-350-400	4,45	SR475MI(ME)324□□□*
388	100,5	350	75,5	150-180-200-250-300-350-400	4,55	SR475MI(ME)350□□□*
412	100,5	374	75,5	150-180-200-250-300-350-400	4,60	SR475MI(ME)374□□□*
536	100,5	498	75,5	150-180-200-250-300-350-400	5,00	SR475MI(ME)498□□□*

\*Complete the code by inserting the value of the radius (R): Ex. SR475MI(ME)119 □ □ □ □  
Chain equipped with nylon frame every pitch: complete the code by inserting the letter D.  
Ex. SR475MI(ME)119150 □ □

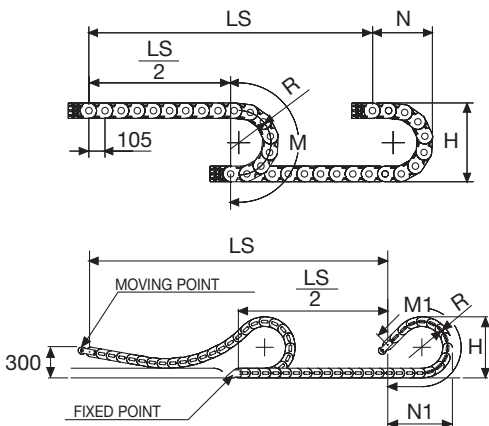

Length of chain (L)

Half travel distance ( $\frac{LS}{2}$ )

plus length of curve (M) or (M1)

$$L = \frac{LS}{2} + M \text{ or } M1$$

R	H	N	M	N1	M1
mm	mm	mm	mm	mm	mm
150	400,5	310	690	365	805
180	460,5	335	775	420	960
200	500,5	355	840	495	1135
250	600,5	405	995	670	1570
300	700,5	460	1155	845	2010
350	800,5	505	1310	1015	2445
400	900,5	560	1470	1190	2885

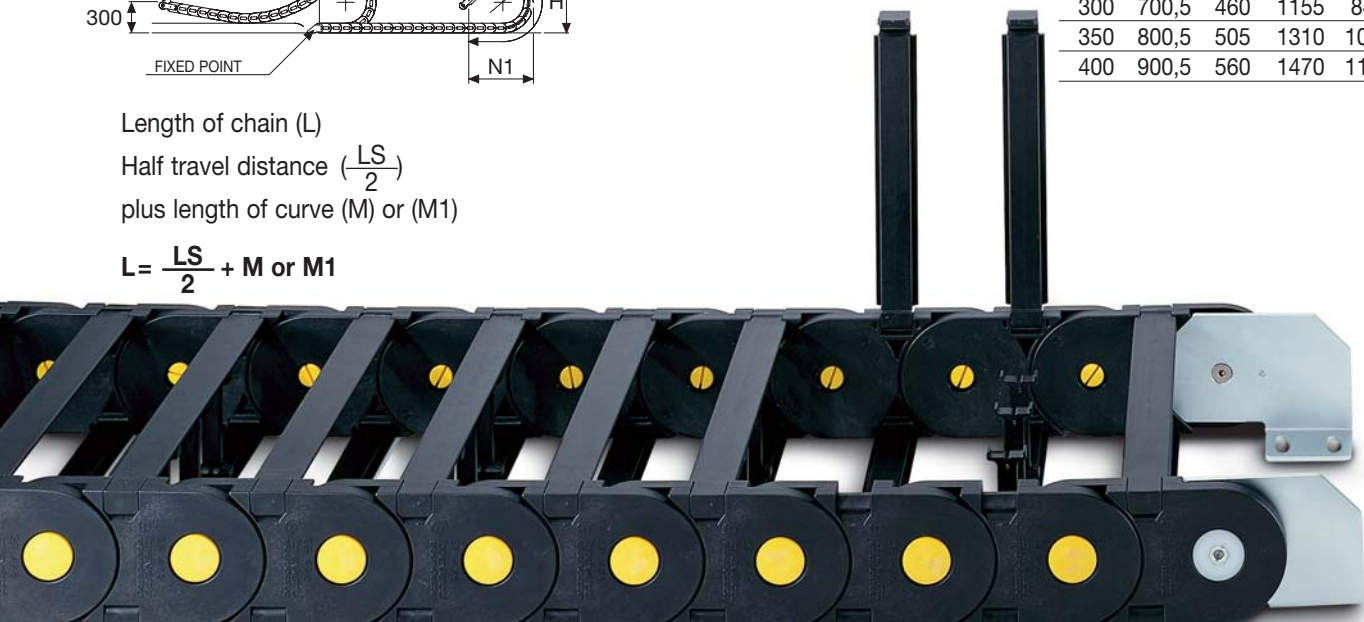

### Self-Supporting Capacity Diagram

The maximum length of the self-supporting capacity ( $\frac{LS}{2}$ ) in relationship to the weight of the cables and hoses contained per linear metre.

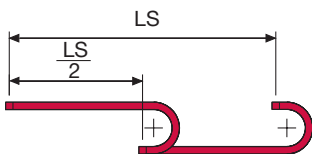
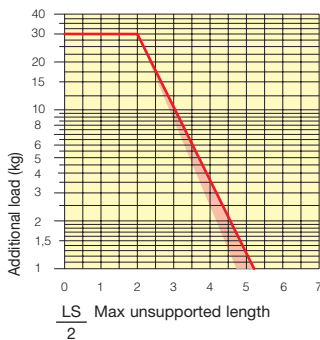

The red marking in the diagram area considers the difference of weight between various widths of chains assembled with nylon frames every second pitch.

For applications with  $\frac{LS}{2}$  and weights not included in the area of the diagram showing self-supporting capacity, verify the possible use of support rollers (see page 30).

### Bright Zinc Plated Steel End Brackets\*

The end brackets set allows the two ends of the chain to be attached to the equipment.

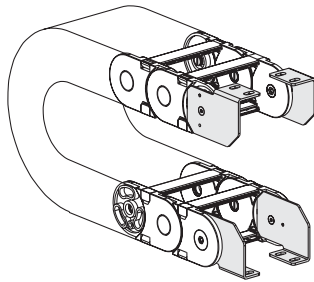
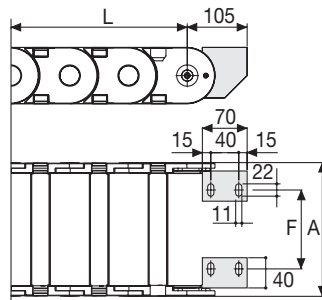

Fig. A  
Chain fixed outside the radius. (Fig A)  
See end brackets mounting variations page 31.



Chain Type	F mm
SR475MI(ME)074	35
SR475MI(ME)094	55
SR475MI(ME)119	80
SR475MI(ME)126	87
SR475MI(ME)149	110
SR475MI(ME)189	150
SR475MI(ME)224	185
SR475MI(ME)250	211
SR475MI(ME)274	235
SR475MI(ME)300	261
SR475MI(ME)324	285
SR475MI(ME)350	311
SR475MI(ME)374	335
SR475MI(ME)498	459

### Bright Zinc Plated Steel Type Part Numbers

Complete Set Assembled	
Chain	End Brackets
Type	Set
SR475...	A475M□□□KM□**

Complete Set Unassembled	
Chain	End Brackets
Type	Set
SR475...	A475M□□□K□**

\*Available on request in stainless steel  
\*\* 1=Pos.1; 2=Pos.2; 3=Pos.3

See end brackets mounting variations page 31.

### Serie Medium

## SR475MI SR475ME

Nylon Cable Chain  
with openable frames

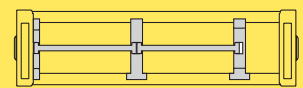

Separation System  
To choose the separators see page. 176

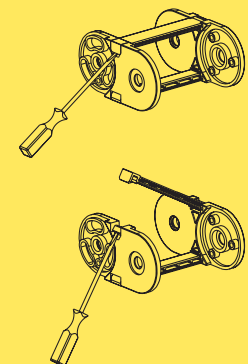

How to open the cover.

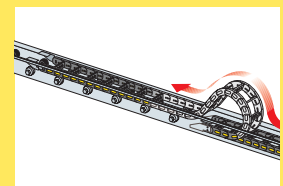

Suitable to long travel distance in frame every pitch version.  
To choose the guide channel see page 162

For further information please consult Brevetti Stendalto's Technical Office

# Serie Medium

## Guide Channel SR305-SR355-SR435

Special Channel guide allows the use of the chain for long travel distance.  
Available in galvanised steel and, on request, in stainless steel

### Single Chain Application

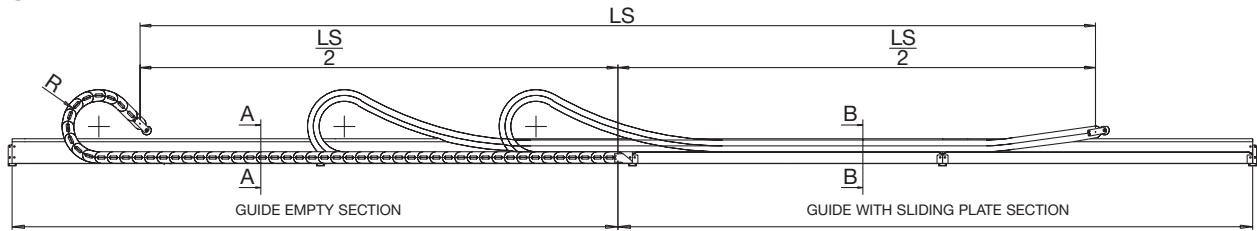

### Double Chain Application

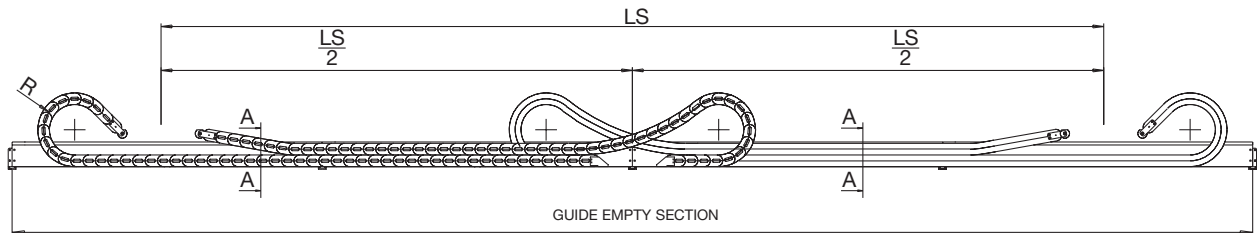

Channel guide is available in kit composed by:  
side walls 2 m standard length  
joining plates  
fixing screws

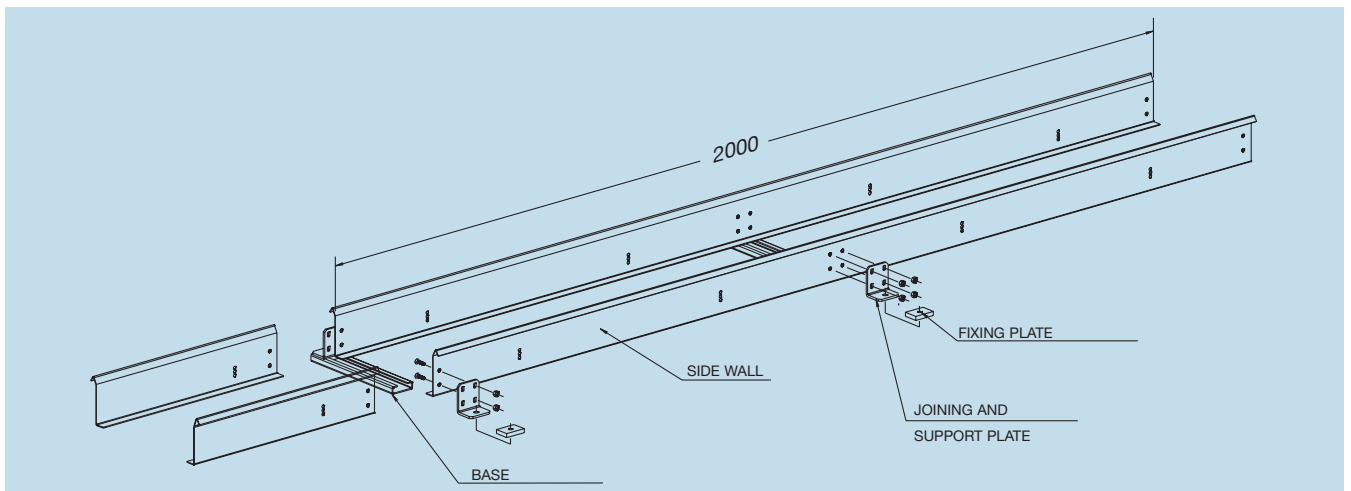

**Guide Empty Section SR305-SR355-SR435**

Section A-A

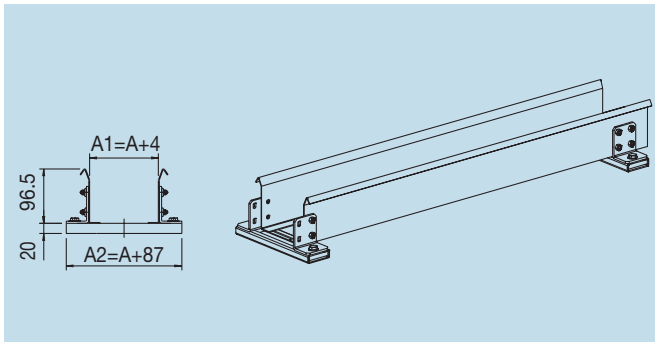

**Guide Sliding Plate Section SR305**

Section B-B

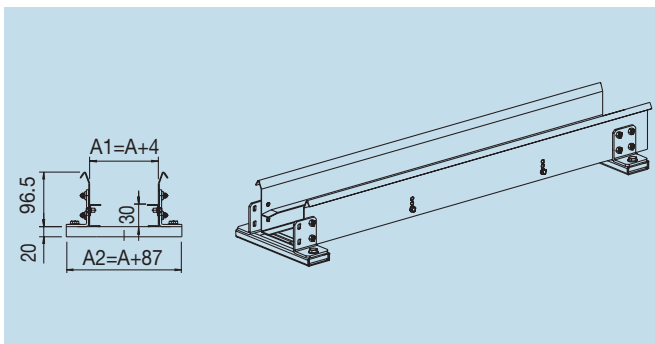

**Guide Sliding Plate Section SR355**

Section B-B

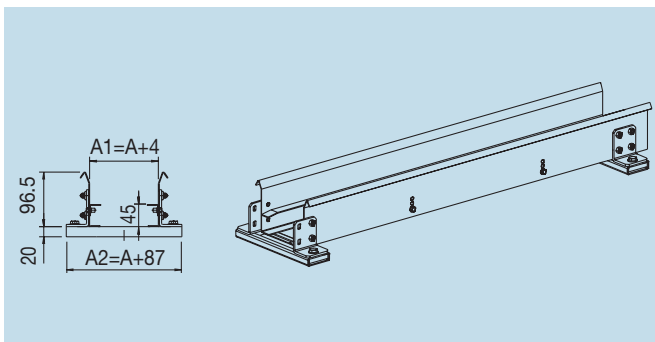

**Guide Sliding Plate Section SR435**

Section B-B

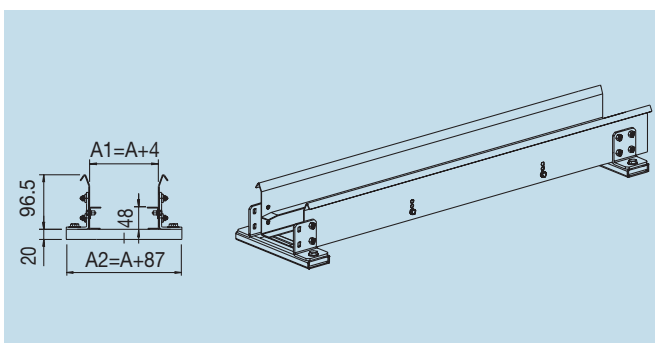

**Part Number**

**CS305...**

How to order

Chain part number **SR305008**

Guide channel part number **CS305008**

**CS355...**

How to order

Chain part number **SR355045**

Guide channel part number **CS355045**

**CS435...**

How to order

Chain part number **SR435050060**

Guide channel part number **CS435050**

**Part Number**

**CA305...**

How to order

Chain part number **SR305008**

Guide channel part number **CA305008**

**Part Number**

**CA355...**

How to order

Chain part number **SR355045**

Guide channel part number **CA355045**

**Part Number**

**CA435...**

How to order

Chain part number **SR435050060**

Guide channel part number **CA435050**

For further information please consult Brevetti Stendalto's Technical Office

# Nylon Cable Chains Heavy Series

Series SR306SI-SR306SE	page 88
Series SR306B	page 90
Series SR306F	page 92
Series SR307SI-SR307SE	page 94
Series SR307B	page 96
Series SR307F	page 98
Series SR308SI-SR308SE	page 100
Series SR308B	page 102
Series SR308F	page 104
Series SR309SI-SR309SE	page 106
Series SR309B	page 108
Series SR310T	page 110
Horizontal Separation	page 176

*Inner surface of chain completely smooth*

*Steel or nylon end brackets*

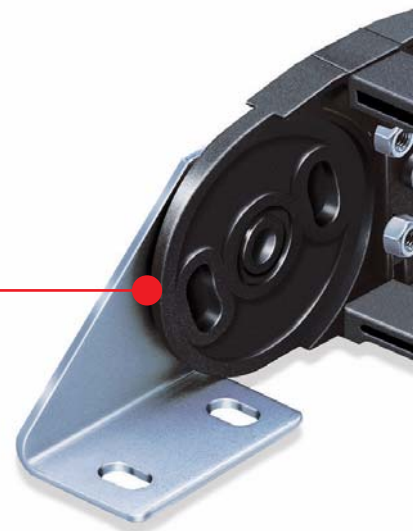

Wide range of cross pieces  
available in the following types:  
Open and close, with a  
"Snap-Fit" action  
Aluminium Rods  
With Pre-Drilled Holes

Nylon separator. Cables can be laid  
apart from each other

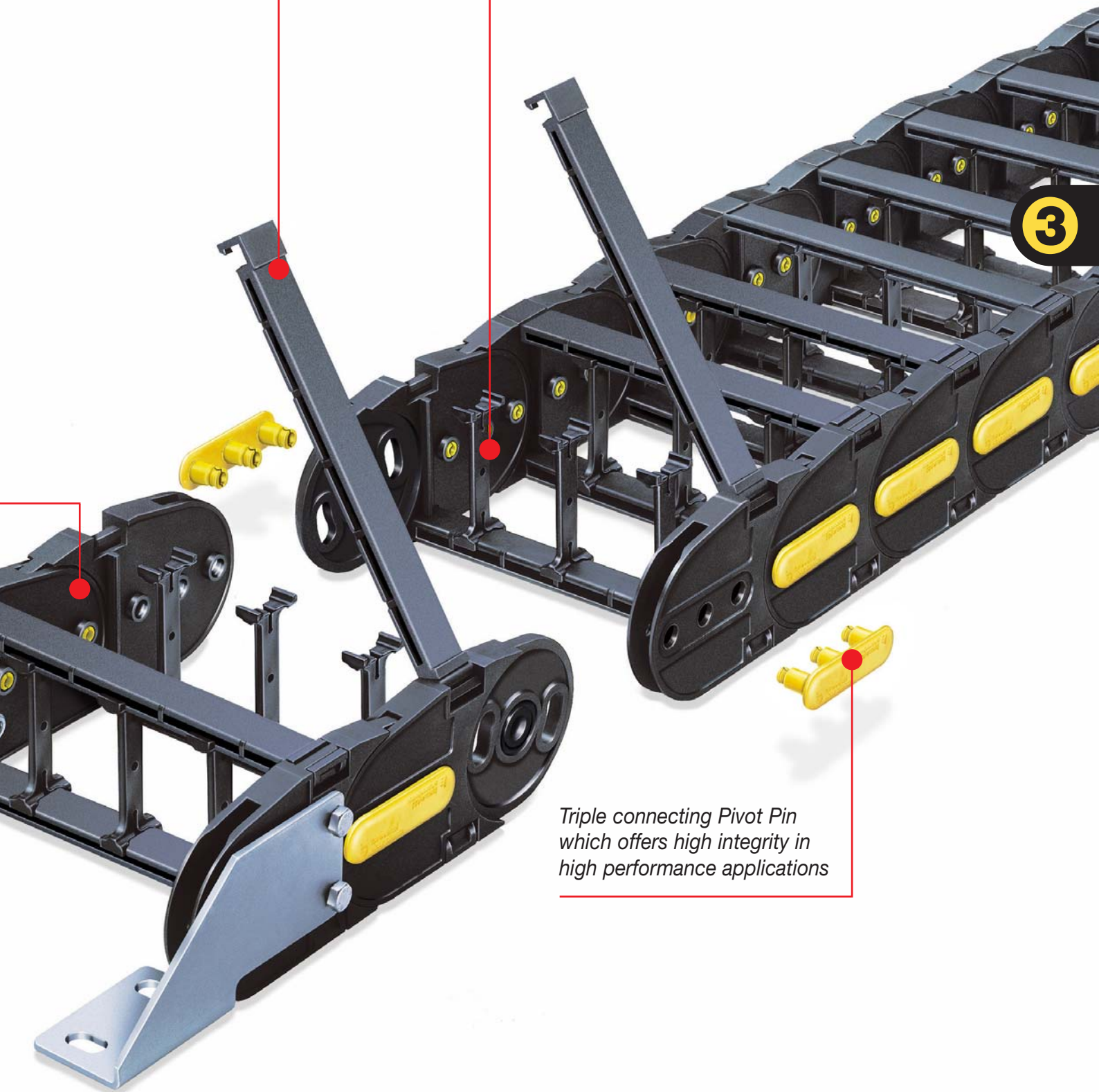

Triple connecting Pivot Pin  
which offers high integrity in  
high performance applications

# Serie Heavy

# SR306SI/SR306SE

## Nylon Cable Chain with openable frames

### Inner height (D) 37 mm

Strong double share Sideband & Frame construction with large anti-friction triple-pin. Frames openable from inner radius (..SI) and outer radius (..SE). As standard the chain comes with frames every second link, on request with frames every link. Vertical and horizontal modular separator system is available.

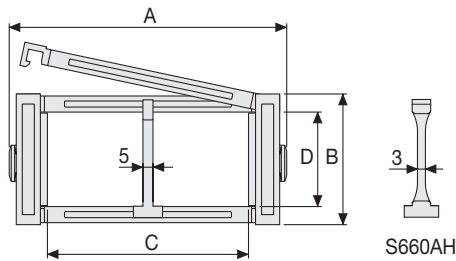

### Separator

- Unassembled Part.no S660A
- Assembled Part.no S660AMC

### Strong-hold separator

for C > 200 mm

- Unassembled Part.no S660AH
- Assembled Part.no S660AHMC

### Pin

Part.no PG307

### Technical characteristics when self-supported

Speed	8 m/s
Acceleration	40 m/s <sup>2</sup>

For higher requirements please consult our technical dept.

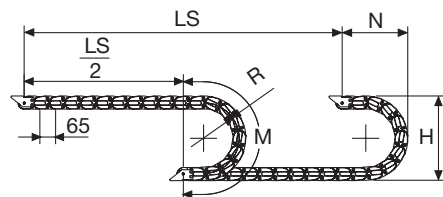

Length of chain (L)  
 Half travel distance ( $\frac{LS}{2}$ )  
 plus length of curve (M)

$$L = \frac{LS}{2} + M$$

R	H	N	M
mm	mm	mm	mm
075	205	170	370
107	269	205	470
150	355	245	605
200	455	295	760
250	555	345	920
300	655	395	1075

A	B	C	D	R	Weight/m	Chain
mm	mm	mm	mm	mm	kg	Part Number
79	55	43	37	075-107-150-200-250-300	1,61	SR306SI(SE)043□□□*
90	55	54	37	075-107-150-200-250-300	1,61	SR306SI(SE)054□□□*
104	55	68	37	075-107-150-200-250-300	1,68	SR306SI(SE)068□□□*
110	55	74	37	075-107-150-200-250-300	1,70	SR306SI(SE)074□□□*
124	55	88	37	075-107-150-200-250-300	1,74	SR306SI(SE)088□□□*
129	55	93	37	075-107-150-200-250-300	1,74	SR306SI(SE)093□□□*
136	55	100	37	075-107-150-200-250-300	1,76	SR306SI(SE)100□□□*
146	55	110	37	075-107-150-200-250-300	1,77	SR306SI(SE)110□□□*
154	55	118	37	075-107-150-200-250-300	1,82	SR306SI(SE)118□□□*
165	55	129	37	075-107-150-200-250-300	1,85	SR306SI(SE)129□□□*
179	55	143	37	075-107-150-200-250-300	1,89	SR306SI(SE)143□□□*
204	55	168	37	075-107-150-200-250-300	1,96	SR306SI(SE)168□□□*
229	55	193	37	075-107-150-200-250-300	2,04	SR306SI(SE)193□□□*
240	55	204	37	075-107-150-200-250-300	2,07	SR306SI(SE)204□□□*
254	55	218	37	075-107-150-200-250-300	2,11	SR306SI(SE)218□□□*
281	55	245	37	075-107-150-200-250-300	2,19	SR306SI(SE)245□□□*
290	55	254	37	075-107-150-200-250-300	2,22	SR306SI(SE)254□□□*
341	55	305	37	075-107-150-200-250-300	2,34	SR306SI(SE)305□□□*
363	55	327	37	075-107-150-200-250-300	2,41	SR306SI(SE)327□□□*
391	55	355	37	075-107-150-200-250-300	2,49	SR306SI(SE)355□□□*

\*Complete the code by inserting the value of the radius (R): Ex. SR306SI(SE)110 □ □ □ □  
 Chain equipped with nylon frame every pitch: complete the code by inserting the letter D.  
 Ex. SR306SI(SE)110150 D





### Self-Supporting Capacity Diagram

The maximum length of the self-supporting capacity ( $\frac{LS}{2}$ ) in relationship to the weight of the cables and hoses contained per linear metre.

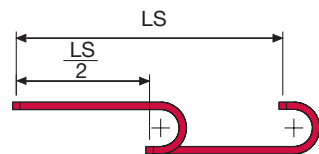
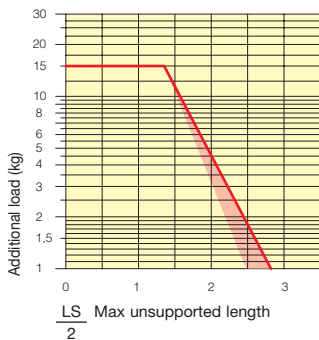

The red marking in the diagram area considers the difference of weight between various widths of chains assembled with nylon frames every second pitch.

For applications with  $\frac{LS}{2}$  and weights not included in the area of the diagram showing self-supporting capacity, verify the possible use of support rollers (see page 30).

### End Brackets

The end brackets set allows the two ends of the chain to be attached to the equipment.

#### Nylon Type

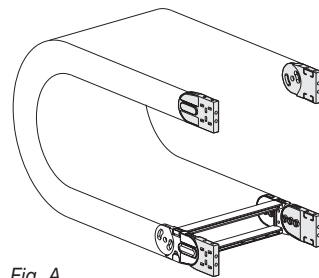

Fig. A  
The chain can be fixed frontally, inner or outer radius. (Fig A)

#### Bright Zinc Plated Steel Type\*

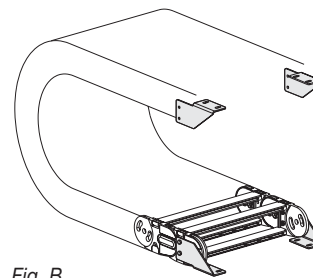
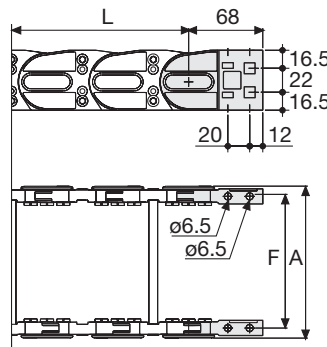

Fig. B  
Chain fixed outside the radius. (Fig B)  
See end brackets mounting variations page 31.



Chain Type	F mm
SR306SI(SE)043	61
SR306SI(SE)054	72
SR306SI(SE)068	86
SR306SI(SE)074	92
SR306SI(SE)088	106
SR306SI(SE)093	111
SR306SI(SE)100	118
SR306SI(SE)110	128
SR306SI(SE)118	136
SR306SI(SE)129	147
SR306SI(SE)143	161
SR306SI(SE)168	186
SR306SI(SE)193	211
SR306SI(SE)204	222
SR306SI(SE)218	236
SR306SI(SE)245	263
SR306SI(SE)254	272
SR306SI(SE)305	323
SR306SI(SE)327	345
SR306SI(SE)355	373

#### Nylon Type Part Numbers

Complete Set Assembled Chain Type	End Brackets Set
SR306SI(SE)...	AN306KM

Complete Set Unassembled Chain Type	End Brackets Set
SR306SI(SE)...	AN306K

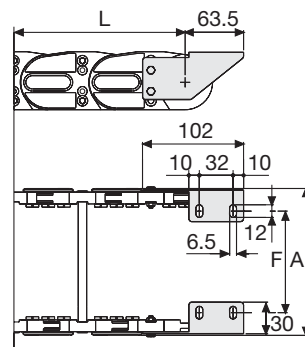

Chain Type	F mm
SR306SI(SE)043	36
SR306SI(SE)054	47
SR306SI(SE)068	61
SR306SI(SE)074	67
SR306SI(SE)088	81
SR306SI(SE)093	86
SR306SI(SE)100	93
SR306SI(SE)110	103
SR306SI(SE)118	111
SR306SI(SE)129	122
SR306SI(SE)143	136
SR306SI(SE)168	161
SR306SI(SE)193	186
SR306SI(SE)204	197
SR306SI(SE)218	211
SR306SI(SE)245	238
SR306SI(SE)254	247
SR306SI(SE)305	298
SR306SI(SE)327	320
SR306SI(SE)355	348

#### Bright Zinc Plated Steel Type Part Numbers

Complete Set Assembled Chain Type	End Brackets Set
SR306SI(SE)...	A306SK □**

Complete Set Unassembled Chain Type	End Brackets Set
SR306SI(SE)...	A306SK □**

\*Available on request in stainless steel  
\*\* 1=Pos.1; 2=Pos.2; 3=Pos.3  
See end brackets mounting variations page 31.

### Serie Heavy

## SR306SI SR306SE

Nylon Cable Chain  
with openable frames

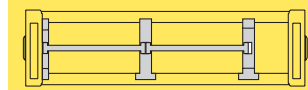

Separation System  
To choose the separators see page. 176

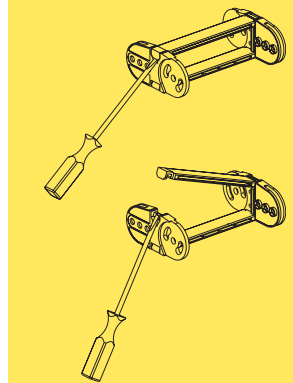

How to open the cover.

#### Protection version



Protection version  
see page 126

For further information please consult Brevetti Stendalto's Technical Office

# Serie Heavy

# SR306B

## Nylon Cable Chain with un-screwable aluminium rods

### Inner height (D) 30 mm

Strong double share Sideband & Frame construction with large anti-friction triple-pin. Alu-rod frames are un-screwable from inner and outer radius. As standard the chain comes with frames every second link, on request with frames every link. Vertical and horizontal separator systems are available.

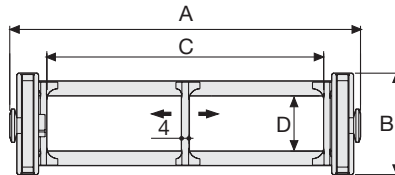

### Separator

- Unassembled	Part.no S2000F
- Assembled	Part.no S2000FMC

### Pin

Part.no PG307

### Technical characteristics when self-supported

Speed	8 m/s
Acceleration	40 m/s <sup>2</sup>

For higher requirements please consult our technical dept.

A	B	C	D	R	Weight/m	Chain
mm	mm	mm	mm	mm	kg	Part Number
115	55	75	30	075-107-150-200-250-300	1,60	SR306B075 □*
140	55	100	30	075-107-150-200-250-300	1,65	SR306B100 □*
190	55	150	30	075-107-150-200-250-300	1,80	SR306B150 □*
240	55	200	30	075-107-150-200-250-300	1,90	SR306B200 □*
290	55	250	30	075-107-150-200-250-300	2,00	SR306B250 □*
340	55	300	30	075-107-150-200-250-300	2,15	SR306B300 □*
C+40	55	.....	30	075-107-150-200-250-300		SR306B □□□ □**

\*Complete the code by inserting the value of the radius (R): Ex. SR306B075 □

Where: 1=075; 2=107; 3=150; 4=200; 5=250; 6=300.

\*\*Complete the code by inserting the value of the quote C and the radius (R): Ex. SR306B □ □ □ □ □

Chain equipped with aluminium rods every pitch: complete the code by inserting the letter D.

Ex. SR306B0751 □

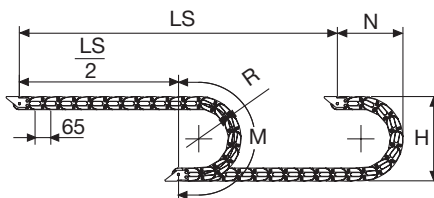

R	H	N	M
mm	mm	mm	mm
075	205	170	370
107	269	205	470
150	355	245	605
200	455	295	760
250	555	345	920
300	655	395	1075

Length of chain (L)

Half travel distance ( $\frac{LS}{2}$ )

plus length of curve (M)

$$L = \frac{LS}{2} + M$$

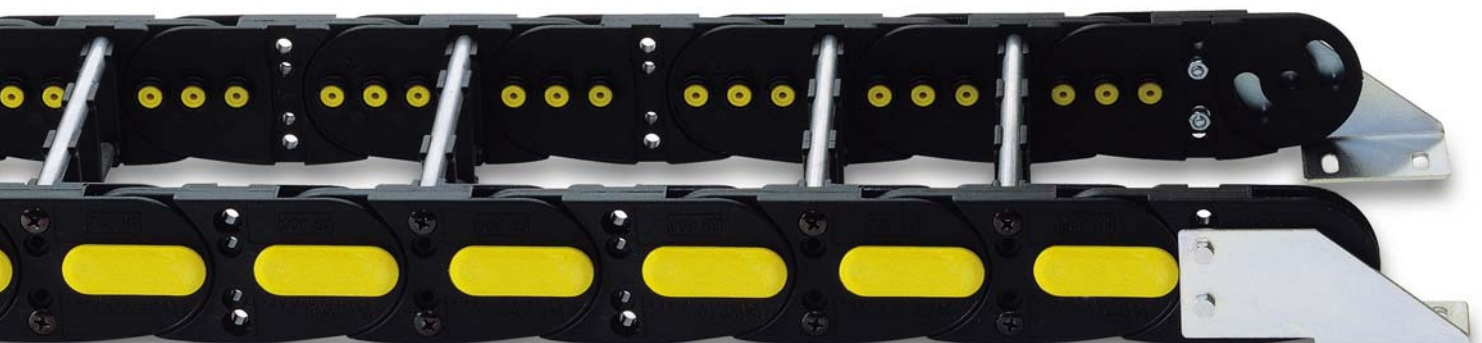

### Self-Supporting Capacity Diagram

The maximum length of the self-supporting capacity ( $\frac{LS}{2}$ ) in relationship to the weight of the cables and hoses contained per linear metre.

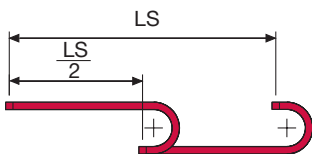
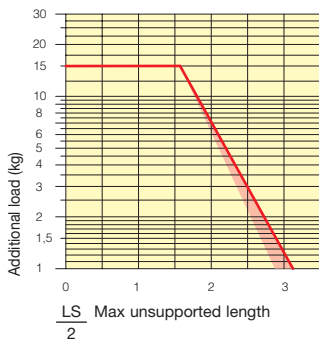

The red marking in the diagram area considers the difference of weight between various widths of chains assembled with rods every second pitch.

For applications with  $\frac{LS}{2}$  and weights not included in the area of the diagram showing self-supporting capacity, verify the possible use of support rollers (see page 30).

### End Brackets

The end brackets set allows the two ends of the chain to be attached to the equipment.

#### Nylon Type

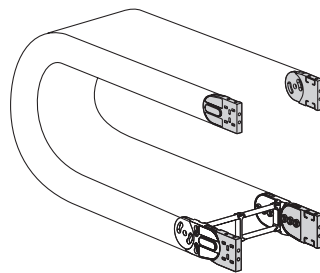

Fig. A  
The chain can be fixed frontally, inner or outer radius. (Fig A)

#### Bright Zinc Plated Steel Type\*

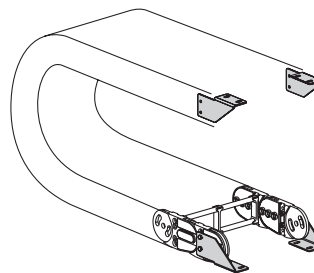
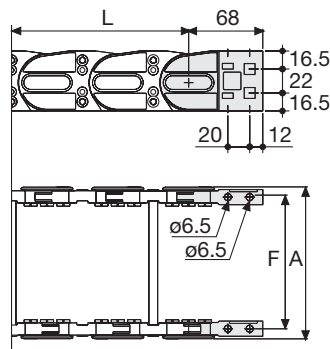

Fig. B  
Chain fixed outside the radius. (Fig B)  
See end brackets mounting variations page 31.



Chain Type	F mm
SR306B075	96
SR306B100	121
SR306B150	171
SR306B200	221
SR306B250	271
SR306B300	321
Special dimension F=A-19	

#### Nylon Type Part Numbers

Complete Set Assembled	
Chain	End Brackets
Type	Set
SR306B...	AN306KM

Complete Set Unassembled	
Chain	End Brackets
Type	Set
SR306B...	AN306K

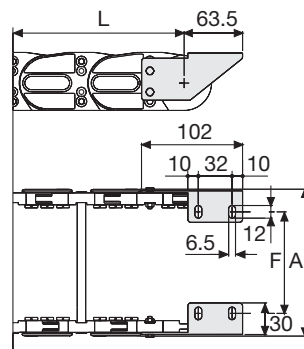

Chain Type	F mm
SR306B075	71
SR306B100	96
SR306B150	146
SR306B200	196
SR306B250	246
SR306B300	296
Special dimension F=A-44	

#### Bright Zinc Plated Steel Type Part Numbers

Complete Set Assembled	
Chain	End Brackets
Type	Set
SR306B...	A306KM □**

Complete Set Unassembled	
Chain	End Brackets
Type	Set
SR306B...	A306K □**

\*Available on request in stainless steel  
\*\* 1=Pos.1; 2=Pos.2; 3=Pos.3  
See end brackets mounting variations page 31.

### Serie Heavy

## SR306B

Nylon Cable Chain with un-screwable aluminium rods

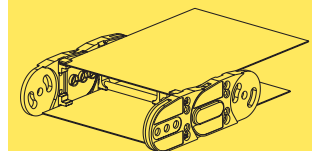

Steel laminar cover.

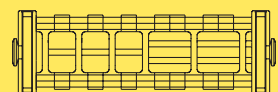

Supplementary movable separators.

Special tool to remove the connecting pivots:  
Part Number PZ036.



For further information please consult Brevetti Stendalto's Technical Office

# Serie Heavy

# SR306F

## Nylon Cable Chain

### with un-screwable split cross pieces with holes

Strong double share Sideband & Frame construction with large anti-friction triple-pin. Un-screwable nylon split cross pieces with different hole combinations. As standard the chain comes with frames every second link, on request with frames every link.

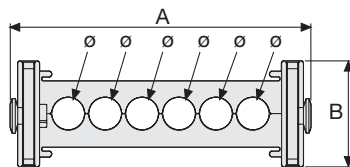

Pin
Part.no PG307

#### Technical characteristics when self-supported

Speed	8 m/s
Acceleration	40 m/s <sup>2</sup>

For higher requirements please consult our technical dept.

A	B	N.	Ø	R	Weight/m	Chain
mm	mm	holes	mm	mm	kg	Part Number
89	55	2	22	075-107-150-200-250-300	1,80	SR306001 □*
155	55	6	17	075-107-150-200-250-300	2,05	SR306002 □*
193	55	6+2	17+20	075-107-150-200-250-300	2,30	SR306003 □*
214	55	6	25	075-107-150-200-250-300	2,55	SR306004 □*
113	55	3	23	075-107-150-200-250-300	1,95	SR306005 □*

\*Complete the code by inserting the value of the radius (R): Ex. SR306002 □

Where: 1=075; 2=107; 3=150; 4=200; 5=250; 6=300

Chain equipped with nylon frame every pitch: complete the code by inserting the letter D.

Ex. SR3060021 □

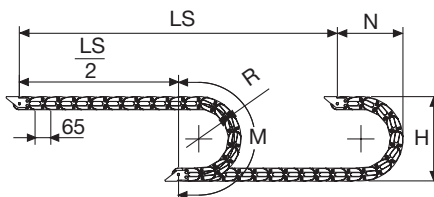

R	H	N	M
mm	mm	mm	mm
075	205	170	370
107	269	205	470
150	355	245	605
200	455	295	760
250	555	345	920
300	655	395	1075

Length of chain (L)

Half travel distance ( $\frac{LS}{2}$ )  
plus length of curve (M)

$$L = \frac{LS}{2} + M$$



### Self-Supporting Capacity Diagram

The maximum length of the self-supporting capacity ( $\frac{LS}{2}$ ) in relationship to the weight of the cables and hoses contained per linear metre.

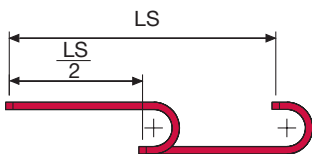
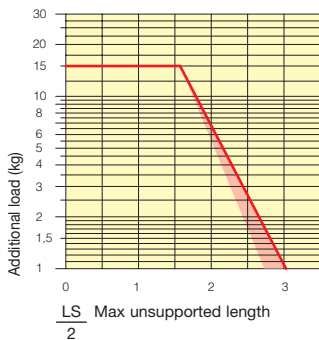

The red marking in the diagram area considers the difference of weight between various widths of chains assembled with nylon cross pieces every second pitch.

For applications with  $\frac{LS}{2}$  and weights not included in the area of the diagram showing self-supporting capacity, verify the possible use of support rollers (see page 30).

### End Brackets

The end brackets set allows the two ends of the chain to be attached to the equipment.

#### Nylon Type

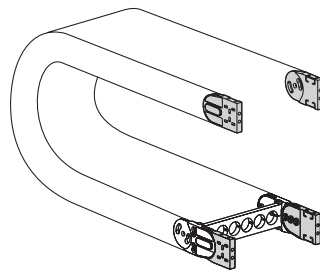

Fig. A  
The chain can be fixed frontally, inner or outer radius. (Fig A)

#### Bright Zinc Plated Steel Type\*

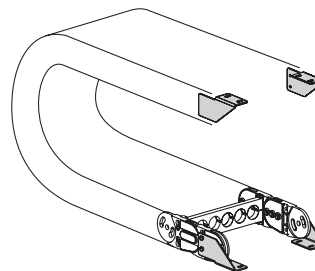
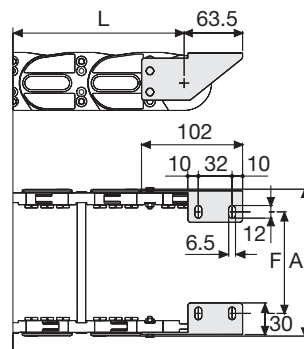
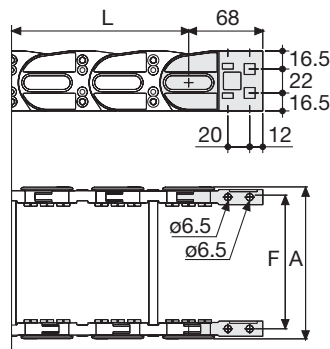

Fig. B  
Chain fixed outside the radius. (Fig B)  
See end brackets mounting variations page 31.



Chain Type	F mm
SR306001	70
SR306002	136
SR306003	174
SR306004	195
SR306005	94

Chain Type	F mm
SR306001	45
SR306002	111
SR306003	149
SR306004	170
SR306005	69

### Nylon Type Part Numbers

Complete Set Assembled	
Chain	End Brackets
Type	Set
SR30600...	AN306KM

Complete Set Unassembled	
Chain	End Brackets
Type	Set
SR30600...	AN306K

### Bright Zinc Plated Steel Type Part Numbers

Complete Set Assembled	
Chain	End Brackets
Type	Set
SR30600...	A306KM □**

Complete Set Unassembled	
Chain	End Brackets
Type	Set
SR30600...	A306K □**

\*Available on request in stainless steel  
\*\* 1=Pos.1; 2=Pos.2; 3=Pos.3  
See end brackets mounting variations page 31.

### Serie Heavy

## SR306F

Nylon Cable Chain with un-screwable nylon split cross pieces with holes

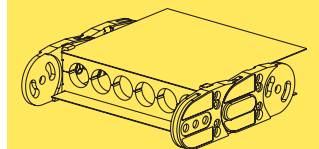

Steel laminar cover.

Special tool to remove the connecting pivots:  
Part Number PZ036.



For further information please consult Brevetti Stendalto's Technical Office

# Serie Heavy

# SR307SI/SR307SE

## Nylon Cable Chain with openable frames

### Inner height (D) 47 mm

Strong double share Sideband & Frame construction with large anti-friction triple-pin. Frames openable from inner radius (..SI) and outer radius (..SE). As standard the chain comes with frames every second link, on request with frames every link. Vertical and horizontal modular separator system is available.

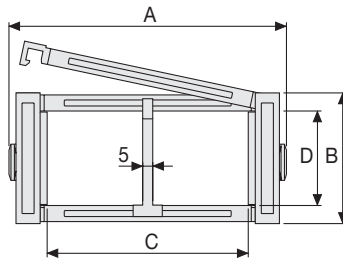

### Separator

- Unassembled Part.no S307S
- Assembled Part.no S307SMC

### Strong-hold separator

for C > 200 mm

- Unassembled Part.no S307SH
- Assembled Part.no S307SHMC

### Pin

Part.no PG307

### Technical characteristics when self-supported

Speed	8 m/s
Acceleration	40 m/s <sup>2</sup>

For higher requirements please consult our technical dept.

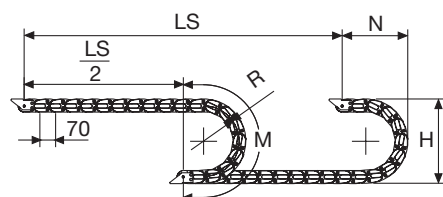

Length of chain (L)  
 Half travel distance ( $\frac{LS}{2}$ )  
 plus length of curve (M)

$$L = \frac{LS}{2} + M$$

R	H	N	M
mm	mm	mm	mm
075	214	180	375
090	244	195	425
120	304	225	520
140	344	245	580
200	464	305	770
250	564	355	925

A	B	C	D	R	Weight/m	Chain
mm	mm	mm	mm	mm	kg	Part Number
80	64	42	47	075-090-120-140-200-250	1,86	SR307SI(SE)042□□□*
91	64	53	47	075-090-120-140-200-250	1,86	SR307SI(SE)053□□□*
105	64	67	47	075-090-120-140-200-250	1,92	SR307SI(SE)067□□□*
111	64	73	47	075-090-120-140-200-250	1,94	SR307SI(SE)073□□□*
125	64	87	47	075-090-120-140-200-250	1,97	SR307SI(SE)087□□□*
130	64	92	47	075-090-120-140-200-250	1,97	SR307SI(SE)092□□□*
137	64	99	47	075-090-120-140-200-250	1,99	SR307SI(SE)099□□□*
147	64	109	47	075-090-120-140-200-250	2,00	SR307SI(SE)109□□□*
155	64	117	47	075-090-120-140-200-250	2,05	SR307SI(SE)117□□□*
166	64	128	47	075-090-120-140-200-250	2,07	SR307SI(SE)128□□□*
180	64	142	47	075-090-120-140-200-250	2,10	SR307SI(SE)142□□□*
205	64	167	47	075-090-120-140-200-250	2,16	SR307SI(SE)167□□□*
230	64	192	47	075-090-120-140-200-250	2,23	SR307SI(SE)192□□□*
241	64	203	47	075-090-120-140-200-250	2,26	SR307SI(SE)203□□□*
255	64	217	47	075-090-120-140-200-250	2,30	SR307SI(SE)217□□□*
282	64	244	47	075-090-120-140-200-250	2,37	SR307SI(SE)244□□□*
291	64	253	47	075-090-120-140-200-250	2,39	SR307SI(SE)253□□□*
342	64	304	47	075-090-120-140-200-250	2,50	SR307SI(SE)304□□□*
364	64	326	47	075-090-120-140-200-250	2,56	SR307SI(SE)326□□□*
392	64	354	47	075-090-120-140-200-250	2,63	SR307SI(SE)354□□□*

\*Complete the code by inserting the value of the radius (R): Ex. SR307SI(SE)117 □ □ □ □  
 Chain equipped with nylon frame every pitch: complete the code by inserting the letter D.  
 Ex. SR307SI(SE)117140 D



### Self-Supporting Capacity Diagram

The maximum length of the self-supporting capacity ( $\frac{LS}{2}$ ) in relationship to the weight of the cables and hoses contained per linear metre.

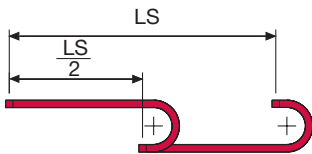
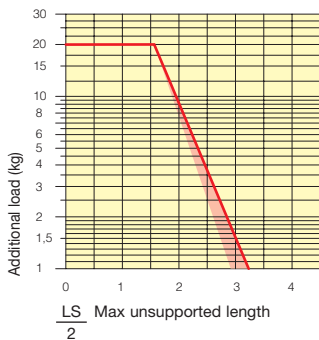

The red marking in the diagram area considers the difference of weight between various widths of chains assembled with nylon frames every second pitch.

For applications with  $\frac{LS}{2}$  and weights not included in the area of the diagram showing self-supporting capacity, verify the possible use of support rollers (see page 30).

### End Brackets

The end brackets set allows the two ends of the chain to be attached to the equipment.

#### Nylon Type

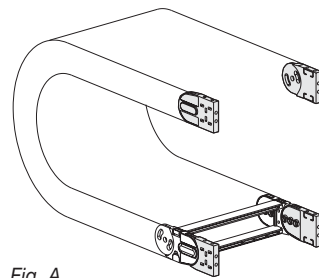

Fig. A  
The chain can be fixed frontally, inner or outer radius. (Fig A)

#### Bright Zinc Plated Steel Type\*

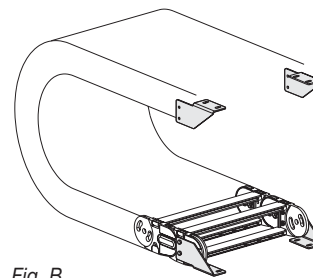
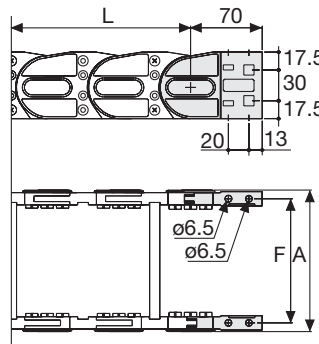

Fig. B  
Chain fixed outside the radius. (Fig B)  
See end brackets mounting variations page 31.



Chain Type	F mm
SR307SI(SE)042	61
SR307SI(SE)053	72
SR307SI(SE)067	86
SR307SI(SE)073	92
SR307SI(SE)087	106
SR307SI(SE)092	111
SR307SI(SE)099	118
SR307SI(SE)109	128
SR307SI(SE)117	136
SR307SI(SE)128	147
SR307SI(SE)142	161
SR307SI(SE)167	186
SR307SI(SE)192	211
SR307SI(SE)203	222
SR307SI(SE)217	236
SR307SI(SE)244	263
SR307SI(SE)253	272
SR307SI(SE)304	323
SR307SI(SE)326	345
SR307SI(SE)354	373

#### Nylon Type Part Numbers

Complete Set Assembled Chain Type	End Brackets Set
SR307SI(SE)...	AN307KM

Complete Set Unassembled Chain Type	End Brackets Set
SR307SI(SE)...	AN307K

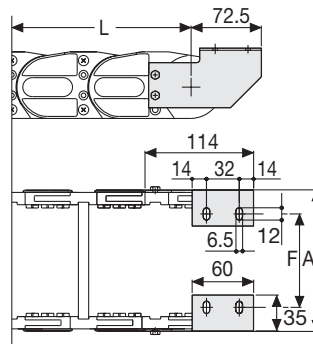

Chain Type	F mm
SR307SI(SE)042	31
SR307SI(SE)053	42
SR307SI(SE)067	56
SR307SI(SE)073	62
SR307SI(SE)087	76
SR307SI(SE)092	81
SR307SI(SE)099	88
SR307SI(SE)109	98
SR307SI(SE)117	106
SR307SI(SE)128	117
SR307SI(SE)142	131
SR307SI(SE)167	156
SR307SI(SE)192	181
SR307SI(SE)203	192
SR307SI(SE)217	206
SR307SI(SE)244	233
SR307SI(SE)253	242
SR307SI(SE)304	293
SR307SI(SE)326	315
SR307SI(SE)354	343

#### Bright Zinc Plated Steel Type Part Numbers

Complete Set Assembled Chain Type	End Brackets Set
SR307SI(SE)...	A307SKM □**

Complete Set Unassembled Chain Type	End Brackets Set
SR307SI(SE)...	A307SK □**

\*Available on request in stainless steel  
\*\* 1=Pos.1; 2=Pos.2; 3=Pos.3  
See end brackets mounting variations page 31.

### Serie Heavy

## SR307SI SR307SE

Nylon Cable Chain  
with openable frames

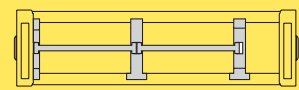

Separation System  
To choose the separators see page. 176

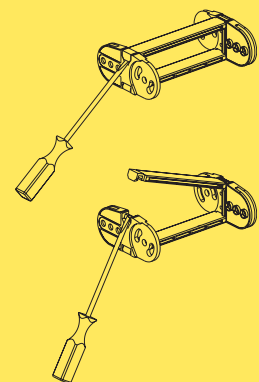

How to open the cover.

Special tool to remove the connecting pivots:  
Part Number PZ036.



For further information please consult Brevetti Stendalto's Technical Office

# Serie Heavy

# SR307B

## Nylon Cable Chain with un-screwable aluminium rods

### Inner height (D) 40 mm

Strong double share Sideband & Frame construction with large anti-friction triple-pin. Alu-rod frames are un-screwable from inner and outer radius. As standard the chain comes with frames every second link, on request with frames every link. Vertical and horizontal separator systems are available.

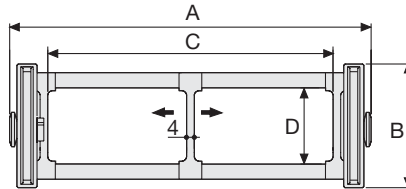

### Separator

- Unassembled	Part.no S307
- Assembled	Part.no S307MC

### Pin

Part.no PG307

### Technical characteristics when self-supported

Speed	8 m/s
Acceleration	40 m/s <sup>2</sup>

For higher requirements please consult our technical dept.

A	B	C	D	R	Weight/m	Chain
mm	mm	mm	mm	mm	kg	Part Number
117	64	75	40	075-090-120-140-200-250	1,80	SR307B075 □*
142	64	100	40	075-090-120-140-200-250	1,85	SR307B100 □*
192	64	150	40	075-090-120-140-200-250	1,95	SR307B150 □*
242	64	200	40	075-090-120-140-200-250	2,05	SR307B200 □*
292	64	250	40	075-090-120-140-200-250	2,15	SR307B250 □*
342	64	300	40	075-090-120-140-200-250	2,25	SR307B300 □*
C+42	64	.....	40	075-090-120-140-200-250		SR307B □□□ □**

\*Complete the code by inserting the value of the radius (R): Ex. SR307B075 □

Where: 0=090; 1=120; 2=140; 3=200; 4=250; 7=075

\*\*Complete the code by inserting the value of the quote C and the radius (R): Ex. SR307B □ □ □ □ □

Chain equipped with aluminium rods every pitch: complete the code by inserting the letter D.

Ex. SR307B0751 □

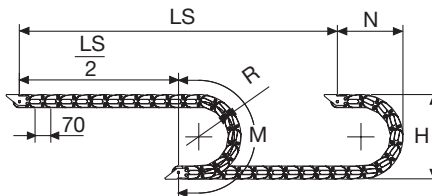

R	H	N	M
mm	mm	mm	mm
075	214	180	375
090	244	195	425
120	304	225	520
140	344	245	580
200	464	305	770
250	564	355	925

Length of chain (L)

Half travel distance ( $\frac{LS}{2}$ )

plus length of curve (M)

$$L = \frac{LS}{2} + M$$





### Self-Supporting Capacity Diagram

The maximum length of the self-supporting capacity ( $\frac{LS}{2}$ ) in relationship to the weight of the cables and hoses contained per linear metre.

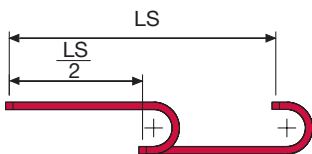
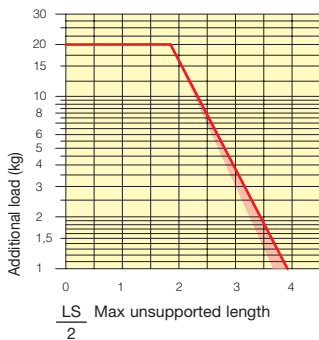

The red marking in the diagram area considers the difference of weight between various widths of chains assembled with rods every second pitch.

For applications with  $\frac{LS}{2}$  and weights not included in the area of the diagram showing self-supporting capacity, verify the possible use of support rollers (see page 30).

### End Brackets

The end brackets set allows the two ends of the chain to be attached to the equipment.

#### Nylon Type

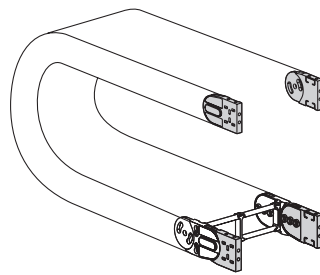

Fig. A  
The chain can be fixed frontally, inner or outer radius. (Fig A)

#### Bright Zinc Plated Steel Type\*

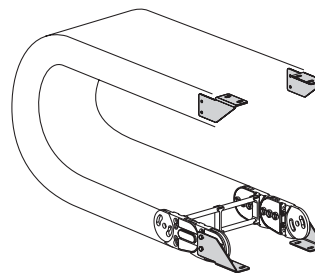
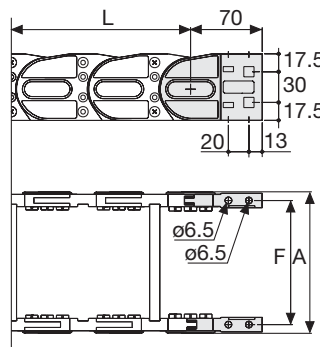
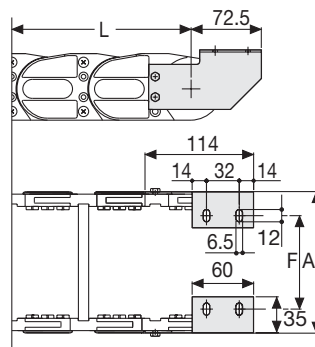

Fig. B  
Chain fixed outside the radius. (Fig B)  
See end brackets mounting variations page 31.



Chain Type	F mm
SR307B075	98
SR307B100	123
SR307B150	173
SR307B200	223
SR307B250	273
SR307B300	323
Special dimension F=A-19	



Chain Type	F mm
SR307B075	68
SR307B100	93
SR307B150	143
SR307B200	193
SR307B250	243
SR307B300	293
Special dimension F=A-49	

### Nylon Type Part Numbers

Complete Set Assembled	
Chain Type	End Brackets Set
SR307B...	AN307KM

Complete Set Unassembled	
Chain Type	End Brackets Set
SR307B...	AN307K

### Bright Zinc Plated Steel Type Part Numbers

Complete Set Assembled	
Chain Type	End Brackets Set
SR307B...	A307KM □**

Complete Set Unassembled	
Chain Type	End Brackets Set
SR307B...	A307K □**

\*Available on request in stainless steel  
\*\* 1=Pos.1; 2=Pos.2; 3=Pos.3  
See end brackets mounting variations page 31.

### Serie Heavy

## SR307B

Nylon Cable Chain with un-screwable aluminium rods

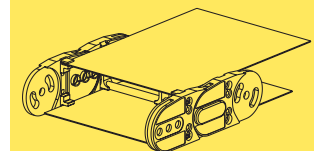

Steel laminar cover.

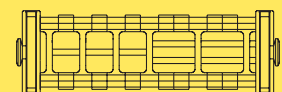

Supplementary movable separators.

Special tool to remove the connecting pivots:  
Part Number PZ036.



For further information please consult Brevetti Stendalto's Technical Office

# Serie Heavy

# SR307F

## Nylon Cable Chain

### with un-screwable split cross pieces with holes

Strong double share Sideband & Frame construction with large anti-friction triple-pin. Un-screwable nylon split cross pieces with different hole combinations. As standard the chain comes with frames every second link, on request with frames every link.

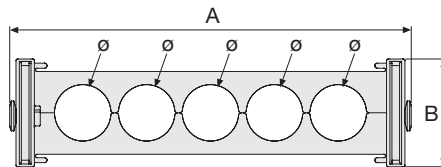

Pin
Part.no PG307

### Technical characteristics when self-supported

Speed	8 m/s
Acceleration	40 m/s <sup>2</sup>

For higher requirements please consult our technical dept.

A	B	N.	Ø	R	Weight/m	Chain
mm	mm	holes	mm	mm	kg	Part Number
126	64	2	34	075-090-120-140-200-250	2,20	SR307001 □*
214	64	6	25	075-090-120-140-200-250	2,50	SR307002 □*
242	64	5	34	075-090-120-140-200-250	2,70	SR307003 □*
279	64	6	34	075-090-120-140-200-250	2,95	SR307004 □*
113	64	3	23	075-090-120-140-200-250	2,10	SR307005 □*

\*Complete the code by inserting the value of the radius (R): Ex. SR307002 □

Where: 0=090; 1=120; 2=140; 3=200; 4=250; 7=075

Chain equipped with nylon frame every pitch: complete the code by inserting the letter D.

Ex. SR3070021 □

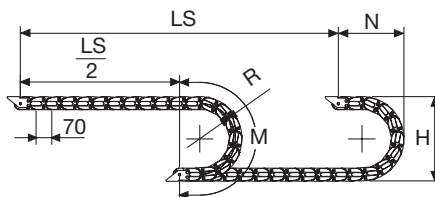

R	H	N	M
mm	mm	mm	mm
075	214	180	375
090	244	195	425
120	304	225	520
140	344	245	580
200	464	305	770
250	564	355	925

Length of chain (L)

Half travel distance ( $\frac{LS}{2}$ ) plus length of curve (M)

$$L = \frac{LS}{2} + M$$



### Self-Supporting Capacity Diagram

The maximum length of the self-supporting capacity ( $\frac{LS}{2}$ ) in relationship to the weight of the cables and hoses contained per linear metre.

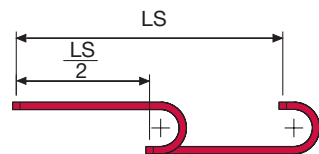
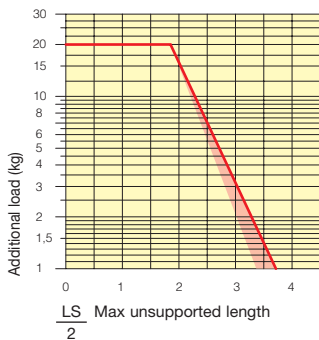

The red marking in the diagram area considers the difference of weight between various widths of chains assembled with nylon cross pieces every second pitch.

For applications with  $\frac{LS}{2}$  and weights not included in the area of the diagram showing self-supporting capacity, verify the possible use of support rollers (see page 30).

### End Brackets

The end brackets set allows the two ends of the chain to be attached to the equipment.

#### Nylon Type

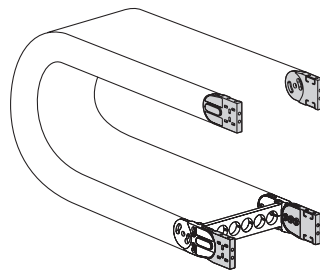

Fig. A  
The chain can be fixed frontally, inner or outer radius. (Fig A)

#### Bright Zinc Plated Steel Type\*

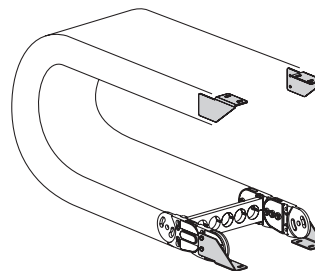
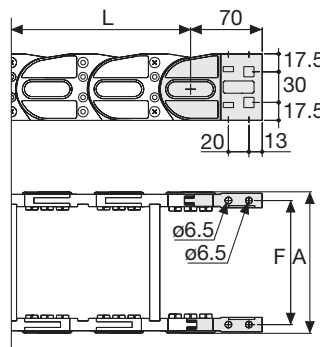
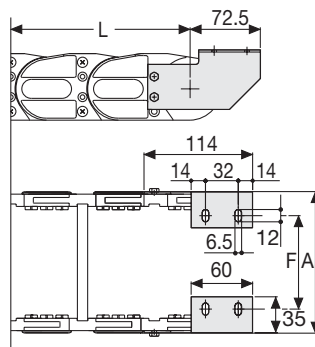

Fig. B  
Chain fixed outside the radius. (Fig B)  
See end brackets mounting variations page 31.



Chain Type	F mm
SR307001	107
SR307002	195
SR307003	223
SR307004	260
SR307005	94



Chain Type	F mm
SR307001	77
SR307002	165
SR307003	193
SR307004	230
SR307005	64

### Nylon Type Part Numbers

Complete Set Assembled	
Chain	End Brackets
Type	Set
SR30700...	AN307KM

Complete Set Unassembled	
Chain	End Brackets
Type	Set
SR30700...	AN307K

### Bright Zinc Plated Steel Type Part Numbers

Complete Set Assembled	
Chain	End Brackets
Type	Set
SR30700...	A307KM □**

Complete Set Unassembled	
Chain	End Brackets
Type	Set
SR30700...	A307K □**

\*Available on request in stainless steel  
\*\* 1=Pos.1; 2=Pos.2; 3=Pos.3  
See end brackets mounting variations page 31.

### Serie Heavy

## SR307F

Nylon Cable Chain with un-screwable nylon split cross pieces with holes

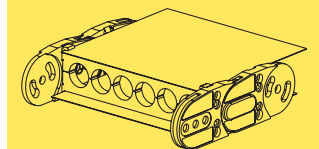

Steel laminar cover.

Special tool to remove the connecting pivots:  
Part Number PZ036.



For further information please consult Brevetti Stendalto's Technical Office

# Serie Heavy

## SR308SI/SR308SE Nylon Cable Chain with openable frames

### Inner height (D) 57 mm

Strong double share Sideband & Frame construction with large anti-friction triple-pin. Frames openable from inner radius (..SI) and outer radius (..SE). As standard the chain comes with frames every second link, on request with frames every link. Vertical and horizontal modular separator system is available.

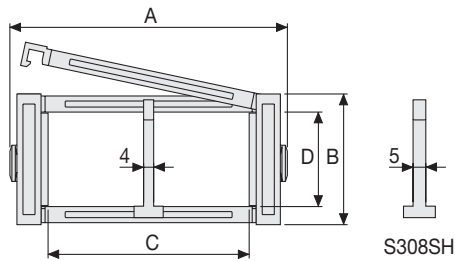

### Separator

- Unassembled Part.no S308C
- Assembled Part.no S308CMC

### Strong-hold separator

for C > 200 mm

- Unassembled Part.no S308SHF
- Assembled Part.no S308SHFMC

### Pin

Part.no PG308

### Technical characteristics when self-supported

Speed	8 m/s
Acceleration	40 m/s <sup>2</sup>

For higher requirements please consult our technical dept.

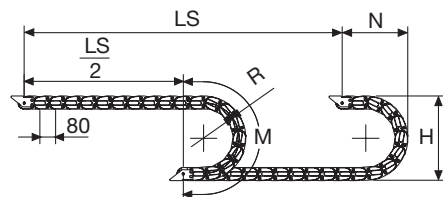

Length of chain (L)  
Half travel distance ( $\frac{LS}{2}$ )  
plus length of curve (M)

$$L = \frac{LS}{2} + M$$

R	H	N	M
mm	mm	mm	mm
150	375	270	635
180	435	300	725
200	475	320	790
230	535	350	885
280	635	400	1040
400	875	520	1420

A	B	C	D	R	Weight/m	Chain
mm	mm	mm	mm	mm	kg	Part Number
82	75	38	57	150-180-200-230-280-400	2,46	SR308SI(SE)038□□□*
93	75	49	57	150-180-200-230-280-400	2,46	SR308SI(SE)049□□□*
107	75	63	57	150-180-200-230-280-400	2,51	SR308SI(SE)063□□□*
113	75	69	57	150-180-200-230-280-400	2,53	SR308SI(SE)069□□□*
127	75	83	57	150-180-200-230-280-400	2,56	SR308SI(SE)083□□□*
132	75	88	57	150-180-200-230-280-400	2,56	SR308SI(SE)088□□□*
139	75	95	57	150-180-200-230-280-400	2,58	SR308SI(SE)095□□□*
149	75	105	57	150-180-200-230-280-400	2,59	SR308SI(SE)105□□□*
157	75	113	57	150-180-200-230-280-400	2,62	SR308SI(SE)113□□□*
168	75	124	57	150-180-200-230-280-400	2,65	SR308SI(SE)124□□□*
182	75	138	57	150-180-200-230-280-400	2,67	SR308SI(SE)138□□□*
207	75	163	57	150-180-200-230-280-400	2,73	SR308SI(SE)163□□□*
232	75	188	57	150-180-200-230-280-400	2,79	SR308SI(SE)188□□□*
243	75	199	57	150-180-200-230-280-400	2,81	SR308SI(SE)199□□□*
257	75	213	57	150-180-200-230-280-400	2,84	SR308SI(SE)213□□□*
284	75	240	57	150-180-200-230-280-400	2,90	SR308SI(SE)240□□□*
293	75	249	57	150-180-200-230-280-400	2,92	SR308SI(SE)249□□□*
344	75	300	57	150-180-200-230-280-400	3,02	SR308SI(SE)300□□□*
366	75	322	57	150-180-200-230-280-400	3,07	SR308SI(SE)322□□□*
394	75	350	57	150-180-200-230-280-400	3,13	SR308SI(SE)350□□□*

\*Complete the code by inserting the value of the radius (R): Ex. SR308SI(SE)105 □ □ □ □  
Chain equipped with nylon frame every pitch: complete the code by inserting the letter D.  
Ex. SR308SI(SE)105150 D





# Serie Heavy

# SR308B

## Nylon Cable Chain with un-screwable aluminium rods

### Inner height (D) 48 mm

Strong double share Sideband & Frame construction with large anti-friction triple-pin. Alu-rod frames are un-screwable from inner and outer radius. As standard the chain comes with frames every second link, on request with frames every link. Vertical and horizontal separator systems are available.

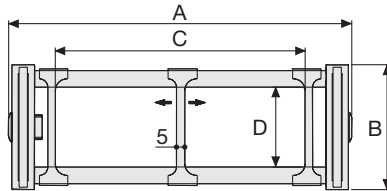

### Separator

- Unassembled	Part.no S3000F
- Assembled	Part.no S3000FMC

### Pin

Part.no PG308

### Technical characteristics when self-supported

Speed	8 m/s
Acceleration	40 m/s <sup>2</sup>

For higher requirements please consult our technical dept.

A	B	C	D	R	Weight/m	Chain
mm	mm	mm	mm	mm	kg	Part Number
156	75	100	48	150-180-200-230-280-400	2,85	SR308B100 □*
206	75	150	48	150-180-200-230-280-400	3,00	SR308B150 □*
256	75	200	48	150-180-200-230-280-400	3,15	SR308B200 □*
306	75	250	48	150-180-200-230-280-400	3,30	SR308B250 □*
356	75	300	48	150-180-200-230-280-400	3,45	SR308B300 □*
C+56	75	.....	48	150-180-200-230-280-400		SR308B □□□ □**

\*Complete the code by inserting the value of the radius (R): Ex. SR308B200 □

Where: 1=150; 2=180; 3=200; 4=230; 5=280; 6=400

\*\*Complete the code by inserting the value of the quote C and the radius (R): Ex. SR308B □ □ □ □ □

Chain equipped with aluminium rods every pitch: complete the code by inserting the letter D.

Ex. SR308B2001 □

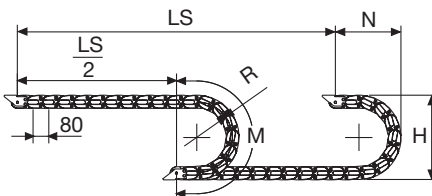

R	H	N	M
mm	mm	mm	mm
150	375	270	635
180	435	300	725
200	475	320	790
230	535	350	885
280	635	400	1040
400	875	520	1420

Length of chain (L)

Half travel distance ( $\frac{LS}{2}$ ) plus length of curve (M)

$$L = \frac{LS}{2} + M$$



### Self-Supporting Capacity Diagram

The maximum length of the self-supporting capacity ( $\frac{LS}{2}$ ) in relationship to the weight of the cables and hoses contained per linear metre.

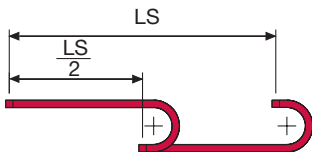
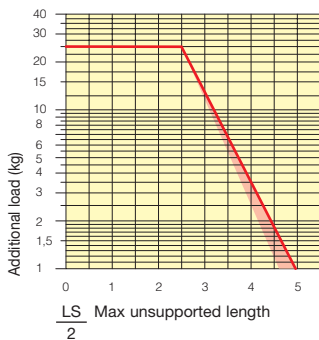

The red marking in the diagram area considers the difference of weight between various widths of chains assembled with rods every second pitch.

For applications with  $\frac{LS}{2}$  and weights not included in the area of the diagram showing self-supporting capacity, verify the possible use of support rollers (see page 30).

### End Brackets

The end brackets set allows the two ends of the chain to be attached to the equipment.

#### Nylon Type

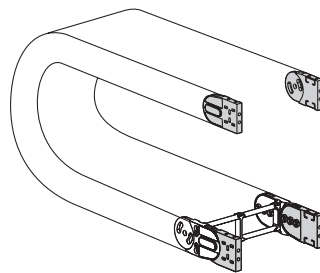

Fig. A  
The chain can be fixed frontally, inner or outer radius. (Fig A)

#### Bright Zinc Plated Steel Type\*

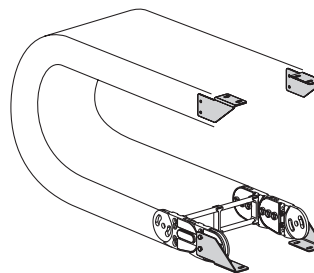
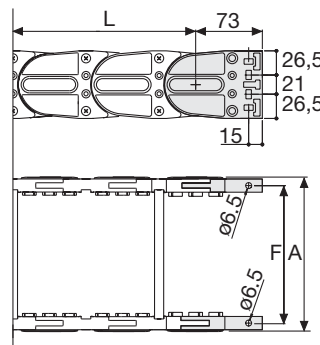
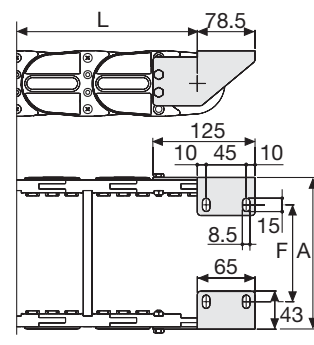

Fig. B  
Chain fixed outside the radius. (Fig B)  
See end brackets mounting variations page 31.



Chain Type	F mm
SR308B100	135
SR308B150	185
SR308B200	235
SR308B250	285
SR308B300	335
Special dimension F=A-21	



Chain Type	F mm
SR308B100	93
SR308B150	143
SR308B200	193
SR308B250	243
SR308B300	293
Special dimension F=A-63	

### Nylon Type Part Numbers

Complete Set Assembled	
Chain	End Brackets
Type	Set
SR308B...	AN308KM

Complete Set Unassembled	
Chain	End Brackets
Type	Set
SR308B...	AN308K

### Bright Zinc Plated Steel Type Part Numbers

Complete Set Assembled	
Chain	End Brackets
Type	Set
SR308B...	A308KM □**

Complete Set Unassembled	
Chain	End Brackets
Type	Set
SR308B...	A308K □**

\*Available on request in stainless steel  
\*\* 1=Pos.1; 2=Pos.2; 3=Pos.3  
See end brackets mounting variations page 31.

### Serie Heavy

## SR308B

Nylon Cable Chain with un-screwable aluminium rods

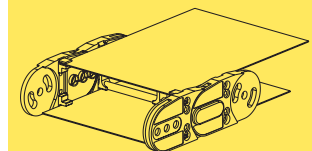

Steel laminar cover.

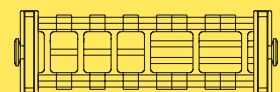

Supplementary movable separators.

Special tool to remove the connecting pivots:  
Part Number PZ038.



For further information please consult Brevetti Stendalto's Technical Office

# Serie Heavy

# SR308F

## Nylon Cable Chain

### with un-screwable split cross pieces with holes

Strong double share Sideband & Frame construction with large anti-friction triple-pin. Un-screwable nylon split cross pieces with different hole combinations. As standard the chain comes with frames every second link, on request with frames every link.

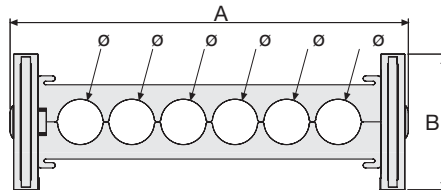

Pin
Part.no PG308

#### Technical characteristics when self-supported

Speed	8 m/s
Acceleration	40 m/s <sup>2</sup>

For higher requirements please consult our technical dept.

A	B	N.	Ø	R	Weight/m	Chain
mm	mm	holes	mm	mm	kg	Part Number
132	75	2	34	150-180-200-230-280-400	3,05	SR308001 □*
220	75	6	25	150-180-200-230-280-400	3,45	SR308002 □*
248	75	5	34	150-180-200-230-280-400	3,60	SR308003 □*
285	75	6	34	150-180-200-230-280-400	3,80	SR308004 □*
132	75	2+1	28-23	150-180-200-230-280-400	3,05	SR308005 □*

\*Complete the code by inserting the value of the radius (R): Ex. SR308003 □

Where: 1=150; 2=180; 3=200; 4=230; 5=280; 6=400

Chain equipped with aluminium rods every pitch: complete the code by inserting the letter D.

Ex. SR3080031 □

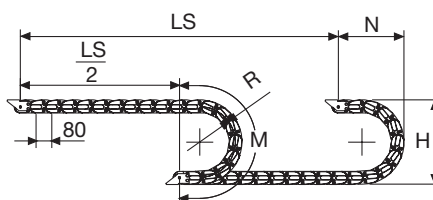

R	H	N	M
mm	mm	mm	mm
150	375	270	635
180	435	300	725
200	475	320	790
230	535	350	885
280	635	400	1040
400	875	520	1420

Length of chain (L)

Half travel distance ( $\frac{LS}{2}$ )  
plus length of curve (M)

$$L = \frac{LS}{2} + M$$





### Self-Supporting Capacity Diagram

The maximum length of the self-supporting capacity ( $\frac{LS}{2}$ ) in relationship to the weight of the cables and hoses contained per linear metre.

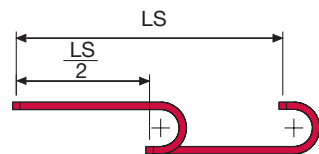
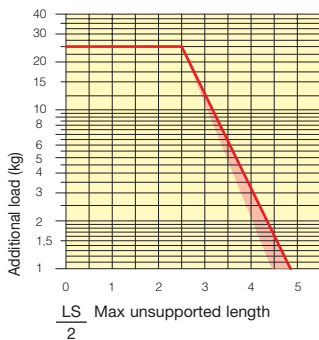

The red marking in the diagram area considers the difference of weight between various widths of chains assembled with nylon cross pieces every second pitch.

For applications with  $\frac{LS}{2}$  and weights not included in the area of the diagram showing self-supporting capacity, verify the possible use of support rollers (see page 30).

### End Brackets

The end brackets set allows the two ends of the chain to be attached to the equipment.

#### Nylon Type

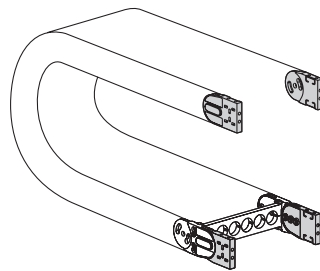

Fig. A  
The chain can be fixed frontally, inner or outer radius. (Fig A)

#### Bright Zinc Plated Steel Type\*

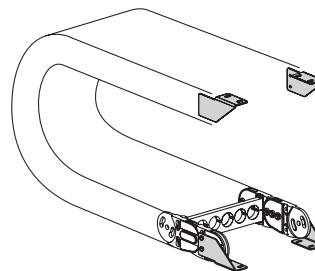
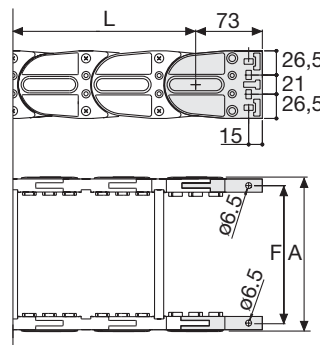
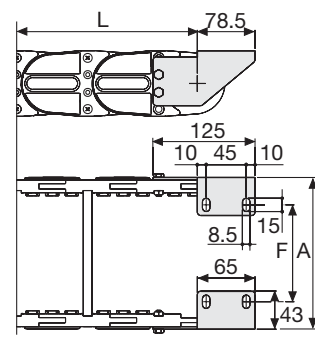

Fig. B  
Chain fixed outside the radius. (Fig B)  
See end brackets mounting variations page 31.



Chain Type	F mm
SR308001	111
SR308002	199
SR308003	227
SR308004	264
SR308005	111



Chain Type	F mm
SR308001	69
SR308002	157
SR308003	185
SR308004	222
SR308005	69

### Nylon Type Part Numbers

Complete Set Assembled	
Chain	End Brackets
Type	Set
SR30800...	AN308KM

Complete Set Unassembled	
Chain	End Brackets
Type	Set
SR30800...	AN308K

### Bright Zinc Plated Steel Type Part Numbers

Complete Set Assembled	
Chain	End Brackets
Type	Set
SR30800...	A308KM □**

Complete Set Unassembled	
Chain	End Brackets
Type	Set
SR30800...	A308K □**

\*Available on request in stainless steel  
\*\* 1=Pos.1; 2=Pos.2; 3=Pos.3  
See end brackets mounting variations page 31.

### Serie Heavy

## SR308F

Nylon Cable Chain with un-screwable nylon split cross pieces with holes

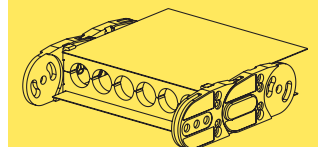

Steel laminar cover.

Special tool to remove the connecting pivots:  
Part Number PZ038.



For further information please consult Brevetti Stendalto's Technical Office

# Serie Heavy

# SR309SI/SR309SE

## Nylon Cable Chain with openable frames

### Inner height (D) 75,5 mm

Strong double share Sideband & Frame construction with large anti-friction triple-pin. Frames openable from inner radius (..SI) and outer radius (..SE). As standard the chain comes with frames every second link, on request with frames every link. Vertical and horizontal modular separator system is available.

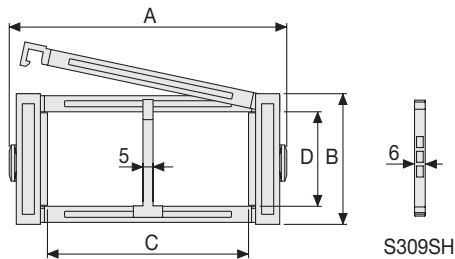

### Separator

- Unassembled Part.no S309S
- Assembled Part.no S309SMC

### Strong-hold separator

for C > 250 mm

- Unassembled Part.no S309SH
- Assembled Part.no S309SHMC

### Pin

Part.no PG309

### Technical characteristics when self-supported

Speed	8 m/s
Acceleration	40 m/s <sup>2</sup>

For higher requirements please consult our technical dept.

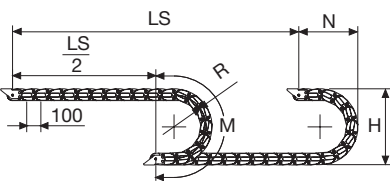

Length of chain (L)

Half travel distance ( $\frac{LS}{2}$ ) plus length of curve (M)

$$L = \frac{LS}{2} + M$$

A	B	C	D	R	Weight/m	Chain
mm	mm	mm	mm	mm	kg	Part Number
120	100	64	75,5	200-250-300-350-400-500	4,03	SR309SI(SE)064□□□*
140	100	84	75,5	200-250-300-350-400-500	4,09	SR309SI(SE)084□□□*
165	100	109	75,5	200-250-300-350-400-500	4,17	SR309SI(SE)109□□□*
172	100	116	75,5	200-250-300-350-400-500	4,20	SR309SI(SE)116□□□*
195	100	139	75,5	200-250-300-350-400-500	4,27	SR309SI(SE)139□□□*
235	100	179	75,5	200-250-300-350-400-500	4,40	SR309SI(SE)179□□□*
270	100	214	75,5	200-250-300-350-400-500	4,51	SR309SI(SE)214□□□*
296	100	240	75,5	200-250-300-350-400-500	4,60	SR309SI(SE)240□□□*
320	100	264	75,5	200-250-300-350-400-500	4,67	SR309SI(SE)264□□□*
346	100	290	75,5	200-250-300-350-400-500	4,75	SR309SI(SE)290□□□*
370	100	314	75,5	200-250-300-350-400-500	4,83	SR309SI(SE)314□□□*
396	100	340	75,5	200-250-300-350-400-500	4,90	SR309SI(SE)340□□□*
420	100	364	75,5	200-250-300-350-400-500	4,99	SR309SI(SE)364□□□*
544	100	488	75,5	200-250-300-350-400-500	5,40	SR309SI(SE)488□□□*

\*Complete the code by inserting the value of the radius (R): Ex. SR309SI(SE)116 □ □ □

Chain equipped with nylon frame every pitch: complete the code by inserting the letter D. Ex. SR309SI(SE)116250 □

R	H	N	M
mm	mm	mm	mm
200	500	350	830
250	600	400	985
300	700	455	1145
350	800	500	1300
400	900	555	1460
500	1100	650	1770



### Self-Supporting Capacity Diagram

The maximum length of the self-supporting capacity ( $\frac{LS}{2}$ ) in relationship to the weight of the cables and hoses contained per linear metre.

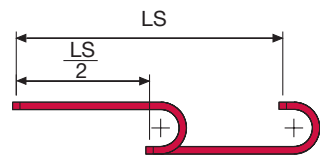
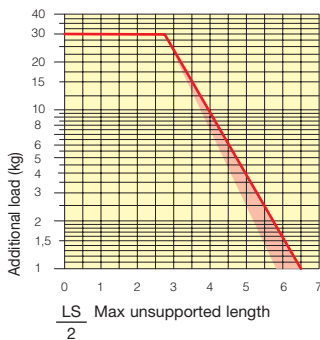

The red marking in the diagram area considers the difference of weight between various widths of chains assembled with nylon frames every second pitch.

For applications with  $\frac{LS}{2}$  and weights not included in the area of the diagram showing self-supporting capacity, verify the possible use of support rollers (see page 30).

### End Brackets

The end brackets set allows the two ends of the chain to be attached to the equipment.

#### Nylon Type

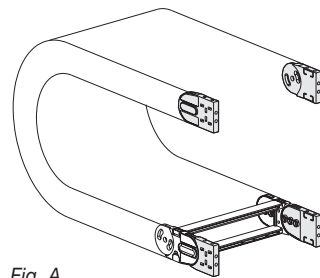

Fig. A  
The chain can be fixed frontally, inner or outer radius. (Fig A)

#### Bright Zinc Plated Steel Type\*

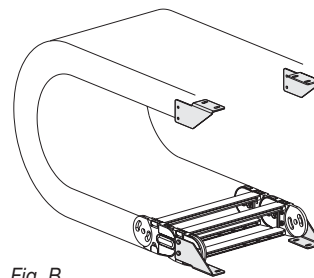
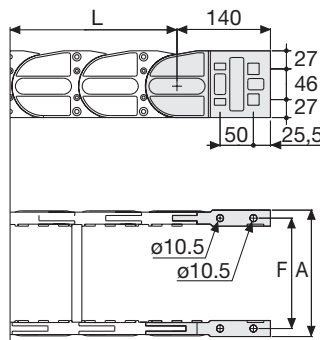

Fig. B  
Chain fixed outside the radius. (Fig B)  
See end brackets mounting variations page 31.



Chain Type	F mm
SR309SI(SE)064	92
SR309SI(SE)084	112
SR309SI(SE)109	137
SR309SI(SE)116	144
SR309SI(SE)139	167
SR309SI(SE)179	207
SR309SI(SE)214	242
SR309SI(SE)240	268
SR309SI(SE)264	292
SR309SI(SE)290	318
SR309SI(SE)314	342
SR309SI(SE)340	368
SR309SI(SE)364	392
SR309SI(SE)488	516

#### Nylon Type Part Numbers

Complete Set Assembled	End Brackets
Chain Type	Set
SR309SI(SE)...	AN309KM

Complete Set Unassembled	End Brackets
Chain Type	Set
SR309SI(SE)...	AN309K

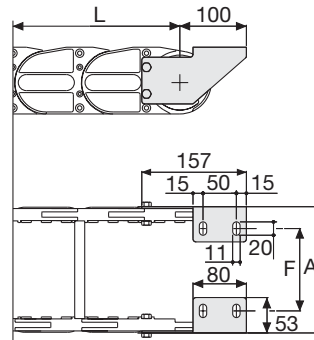

Chain Type	F mm
SR309SI(SE)064	50
SR309SI(SE)084	70
SR309SI(SE)109	95
SR309SI(SE)116	102
SR309SI(SE)139	125
SR309SI(SE)179	165
SR309SI(SE)214	200
SR309SI(SE)240	226
SR309SI(SE)264	250
SR309SI(SE)290	276
SR309SI(SE)314	300
SR309SI(SE)340	326
SR309SI(SE)364	350
SR309SI(SE)488	474

#### Bright Zinc Plated Steel Type Part Numbers

Complete Set Assembled	End Brackets
Chain Type	Set
SR309SI(SE)...	A309SKM <input type="checkbox"/> **

Complete Set Unassembled	End Brackets
Chain Type	Set
SR309SI(SE)...	A309SK <input type="checkbox"/> **

\*Available on request in stainless steel  
\*\* 1=Pos.1; 2=Pos.2; 3=Pos.3  
See end brackets mounting variations page 31.

### Serie Heavy

## SR309SI SR309SE

Nylon Cable Chain  
with openable frames

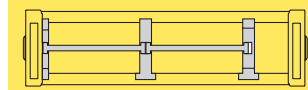

Separation System  
To choose the separators see page. 176

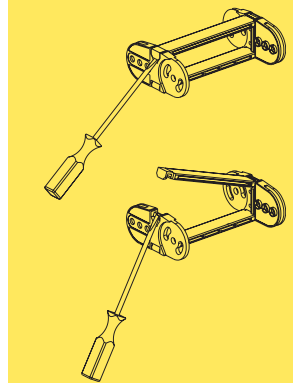

How to open the cover.

#### Protection version



Protection version  
see page 132

For further information please consult Brevetti Stendalto's Technical Office

# Serie Heavy

# SR309B

## Nylon Cable Chain with un-screwable aluminium rods

### Inner height (D) 70 mm

Strong double share Sideband & Frame construction with large anti-friction triple-pin. Alu-rod frames are un-screwable from inner and outer radius. As standard the chain comes with frames every second link, on request with frames every link. Vertical and horizontal separator systems are available.

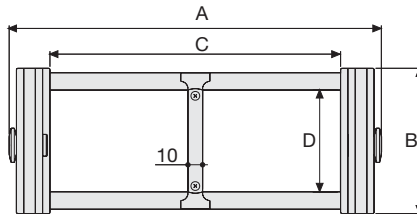

### Separator

- Unassembled	Part.no S309C
- Assembled	Part.no S309CMC

### Pin

Part.no PG309

### Technical characteristics when self-supported

Speed	8 m/s
Acceleration	40 m/s <sup>2</sup>

For higher requirements please consult our technical dept.

A	B	C	D	R	Weight/m	Chain
mm	mm	mm	mm	mm	kg	Part Number
156	100	100	70	200-250-300-350-400-500	4,20	SR309B100 □*
206	100	150	70	200-250-300-350-400-500	4,40	SR309B150 □*
256	100	200	70	200-250-300-350-400-500	4,55	SR309B200 □*
306	100	250	70	200-250-300-350-400-500	4,70	SR309B250 □*
356	100	300	70	200-250-300-350-400-500	4,85	SR309B300 □*
456	100	400	70	200-250-300-350-400-500	5,20	SR309B400 □*
C+56	100	.....	70	200-250-300-350-400-500		SR309B □□□ □**

\*Complete the code by inserting the value of the radius (R): Ex. SR309B150 □  
Where: 2=200; 3=250; 4=300; 5=350; 6=400; 7=500

\*\*Complete the code by inserting the value of the quote C and the radius (R): Ex. SR309B □ □ □ □ □  
Chain equipped with aluminium rods every pitch: complete the code by inserting the letter D.  
Ex. SR309B1502 □

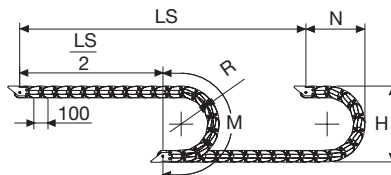

Length of chain (L)  
Half travel distance ( $\frac{LS}{2}$ )  
plus length of curve (M)

$$L = \frac{LS}{2} + M$$

R	H	N	M
mm	mm	mm	mm
200	500	350	830
250	600	400	985
300	700	455	1145
350	800	500	1300
400	900	555	1460
500	1100	650	1770



### Self-Supporting Capacity Diagram

The maximum length of the self-supporting capacity ( $\frac{LS}{2}$ ) in relationship to the weight of the cables and hoses contained per linear metre.

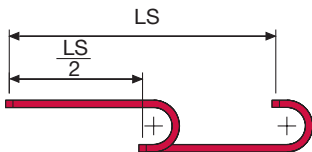
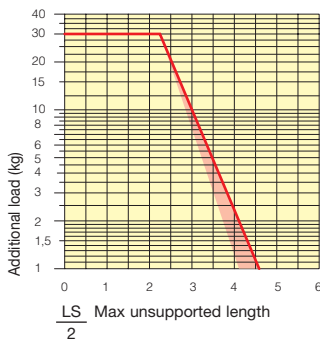

The red marking in the diagram area considers the difference of weight between various widths of chains assembled with rods every second pitch.

For applications with  $\frac{LS}{2}$  and weights not included in the area of the diagram showing self-supporting capacity, verify the possible use of support rollers (see page 30).

### End Brackets

The end brackets set allows the two ends of the chain to be attached to the equipment.

#### Nylon Type

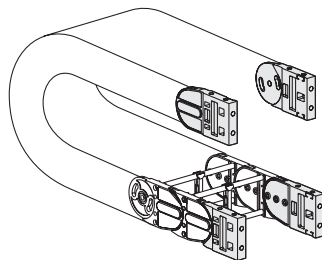
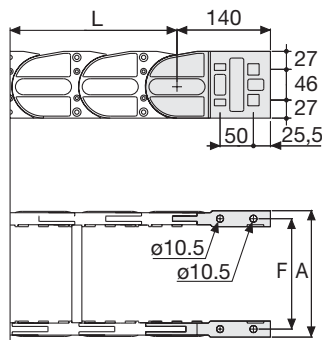

Fig. A  
The chain can be fixed frontally, inner or outer radius. (Fig A)



Chain Type	F mm
SR309B100	129
SR309B150	179
SR309B200	229
SR309B250	279
SR309B300	329
SR309B400	429
Special dimension F=A-27	

#### Bright Zinc Plated Steel Type\*

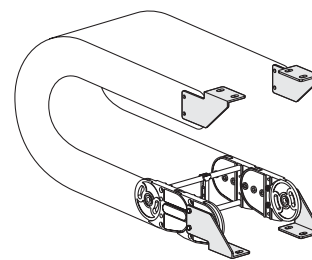
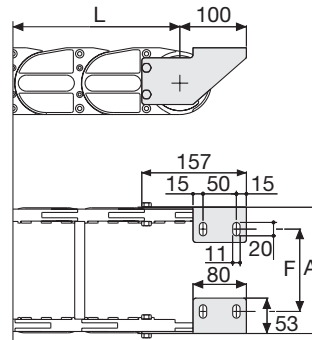

Fig. B  
Chain fixed outside the radius. (Fig B)  
See end brackets mounting variations page 31.



Chain Type	F mm
SR309B100	87
SR309B150	137
SR309B200	187
SR309B250	237
SR309B300	287
SR309B400	387
Special dimension F=A-69	

### Nylon Type Part Numbers

Complete Set Assembled	
Chain	End Brackets
Type	Set
SR309B...	AN309KM

Complete Set Unassembled	
Chain	End Brackets
Type	Set
SR309B...	AN309K

### Bright Zinc Plated Steel Type Part Numbers

Complete Set Assembled	
Chain	End Brackets
Type	Set
SR309B...	A309KM □**

Complete Set Unassembled	
Chain	End Brackets
Type	Set
SR309B...	A309K □**

\*Available on request in stainless steel  
\*\* 1=Pos.1; 2=Pos.2; 3=Pos.3  
See end brackets mounting variations page 31.

### Serie Heavy

## SR309B

Nylon Cable Chain with un-screwable aluminium rods

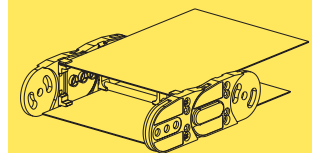

Steel laminar cover.

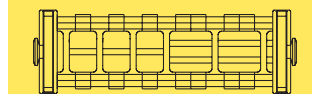

Supplementary movable separators.

### Version with aluminium draw plates



On request available with aluminium draw plates

Example Part Number:  
SR309T □□□\*□□□\*\*

\* Inner width (C)  
\*\* Bending radius (R)

For further information please consult Brevetti Stendalto's Technical Office



# Serie Heavy

# SR310T

## Nylon Cable Chain

## with un-screwable aluminium draw plates

### Inner height (D) 112 mm

Strong double share Sideband & Frame construction with three large anti-friction single-pin/bush.  
Alu-draw frames are mounted on every link and are un-screwable from inner and outer radius.  
Vertical and horizontal separator systems are available.

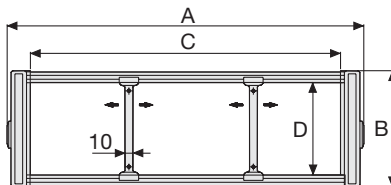

### Separator

- Unassembled Part.no S310TC  
- Assembled Part.no S310TMC

### Pin

Part.no B310-PG310

### Technical characteristics when self-supported

Speed	4 m/s
Acceleration	20 m/s <sup>2</sup>

For higher requirements please consult our technical dept.

A	B	C	D	R	Weight/m	Chain
mm	mm	mm	mm	mm	kg	Part Number
260	150	200	112	200-300-400-500-600-700-750	7,15	SR310T200□□□*
360	150	300	112	200-300-400-500-600-700-750	7,60	SR310T300□□□*
460	150	400	112	200-300-400-500-600-700-750	8,05	SR310T400□□□*
560	150	500	112	200-300-400-500-600-700-750	8,50	SR310T500□□□*
660	150	600	112	200-300-400-500-600-700-750	9,00	SR310T600□□□*
C+60	150	....	112	200-300-400-500-600-700-750		SR310T□□□□□**

\*Complete the code by inserting the value of the radius (R): Ex. SR310T200 □□□

\*\*Complete the code by inserting the value of the quote C and the radius (R): Ex. SR310T □□□□□

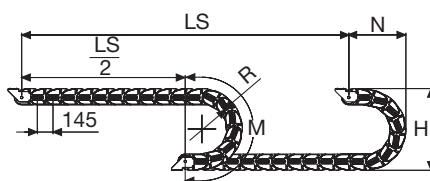

R	H	N	M
mm	mm	mm	mm
200	550	420	920
300	750	525	1235
400	950	625	1550
500	1150	720	1860
600	1350	820	2175
700	1550	920	2490
750	1650	970	2650

Length of chain (L)  
Half travel distance ( $\frac{LS}{2}$ )  
plus length of curve (M)

$$L = \frac{LS}{2} + M$$



### Self-Supporting Capacity Diagram

The maximum length of the self-supporting capacity ( $\frac{LS}{2}$ ) in relationship to the weight of the cables and hoses contained per linear metre.

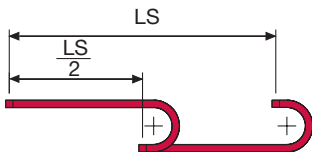
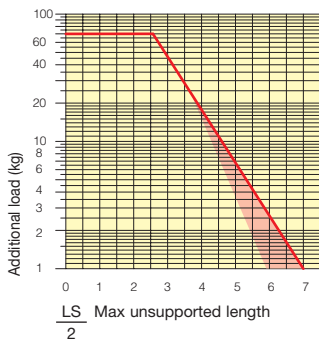

The red marking in the diagram area considers the difference of weight between various widths of chain.

For applications with  $\frac{LS}{2}$  and weights not included in the area of the diagram showing self-supporting capacity, verify the possible use of support rollers (see page 30).

### End Brackets

The end brackets set allows the two ends of the chain to be attached to the equipment.

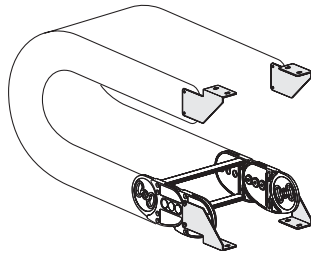
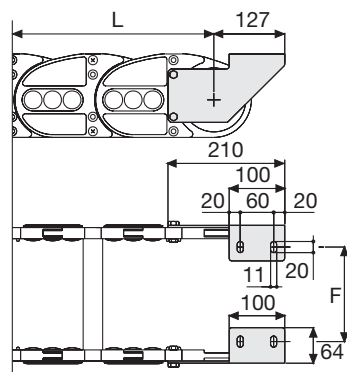

Fig. A  
Chain fixed outside the radius. (Fig A)  
See end brackets mounting variations page 31.



Chain Type	F mm
SR310T200	180
SR310T300	280
SR310T400	380
SR310T500	480
SR310T600	580
Special dimension F=A-80	

### Bright Zinc Plated Steel Type Part Numbers

Complete Set Assembled	
Chain Type	End Brackets Set
SR310T...	A310KM □**

Complete Set Unassembled	
Chain Type	End Brackets Set
SR310T...	A310K □**

\*Available on request in stainless steel  
\*\* 1=Pos.1; 2=Pos.2; 3=Pos.3  
See end brackets mounting variations page 31.

### Serie Heavy

## SR310T

Nylon Cable Chain with un-screwable aluminium draw plates

3

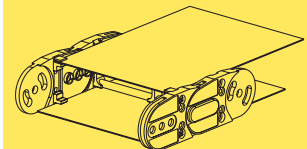

Steel laminar cover.

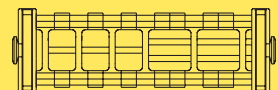

Supplementary movable separators.

For further information please consult Brevetti Stendalto's Technical Office

# Nylon Cable Chains Protection Series

Series SR435PI-SR435PE	page 114
Series SR445PI-SR445PE	page 116
Series SR445AI-SR445AE	page 118 <b>New</b>
Series SR475PI-SR475PE	page 120
Series SR660	page 122
Series SR770	page 124
Series SR306CI-SR306CE	page 126 <b>New</b>
Series SR308CI-SR308CE	page 128 <b>New</b>
Series SR309C	page 130
Series SR309CI-SR309CE	page 132 <b>New</b>

*Inner surface of chain  
completely smooth*



*Special End Brackets on  
moving end of chain*

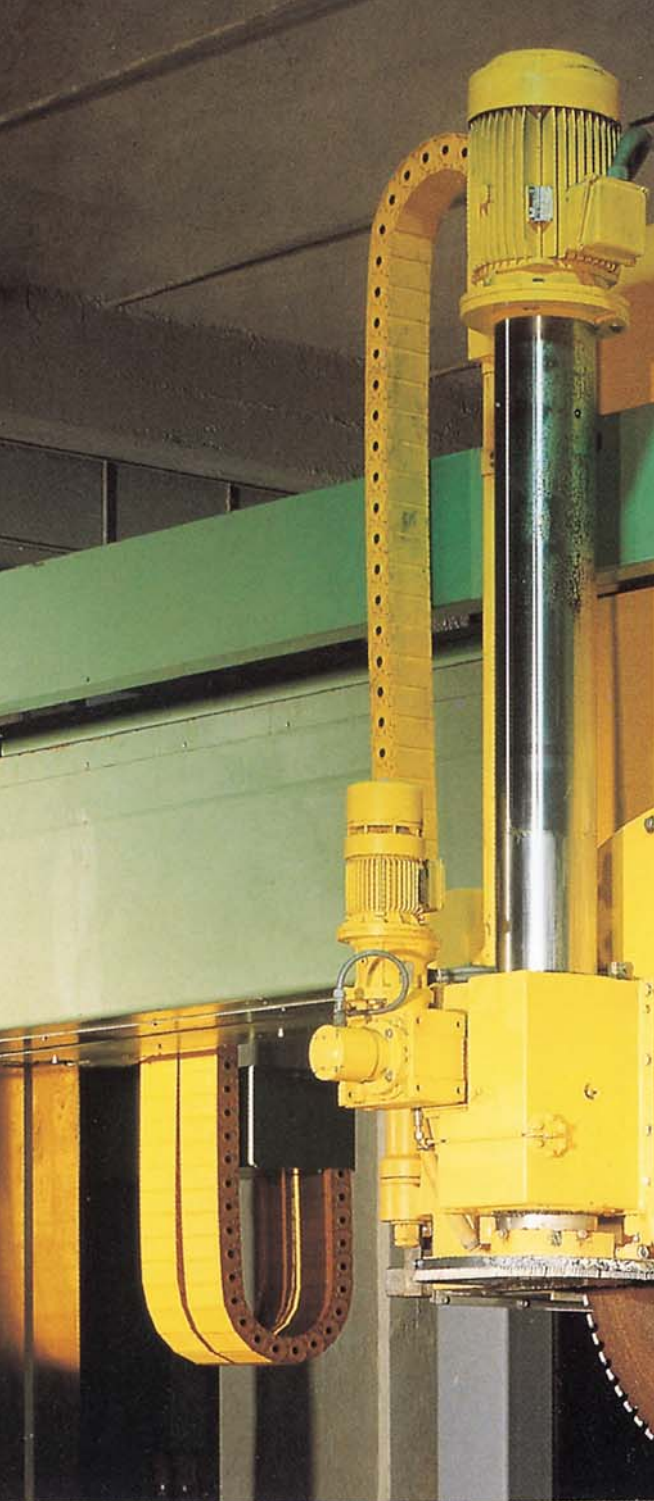



Quickly removable covers with a "Snap-Fit" action

Completely enclosed design to protect chain contents from steel and wood chips, dust, etc.

3

Nylon separator cables can be laid apart from each other

Connecting Pivot Pin which offers high integrity in high performance applications

# Serie Protection

## SR435PI/SR435PE Nylon Protection Cable Chain with openable covers

### Inner height (D) 35 mm

Sideband & Frame construction with large anti-friction single-pin.

Covers are openable from inner radius (SR435PI) or from outer radius (SR435PE).

Vertical separators are available.

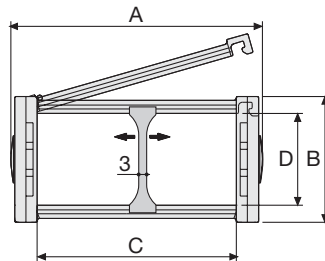

### Separator

- Unassembled	Part.no S4353
- Assembled	Part.no S4353MC

### Pin

Part.no PG4353

### Technical characteristics when self-supported

Speed	10 m/s
Acceleration	50 m/s <sup>2</sup>

For higher requirements please consult our technical dept.

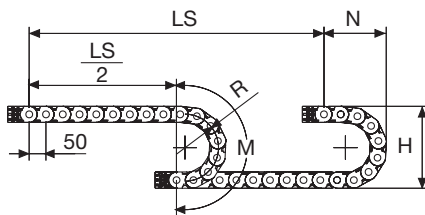

Length of chain (L)

Half travel distance ( $\frac{LS}{2}$ )  
plus length of curve (M)

$$L = \frac{LS}{2} + M$$

A	B	C	D	R	Weight/m	Chain
mm	mm	mm	mm	mm	kg	Part Number
60	49	40	35	075-100-125-150-200	1,25	SR435PI(PE)040□□□*
70	49	50	35	075-100-125-150-200	1,40	SR435PI(PE)050□□□*
80	49	60	35	075-100-125-150-200	1,45	SR435PI(PE)060□□□*
96	49	76	35	075-100-125-150-200	1,60	SR435PI(PE)076□□□*
123	49	103	35	075-100-125-150-200	1,90	SR435PI(PE)103□□□*
145	49	125	35	075-100-125-150-200	2,10	SR435PI(PE)125□□□*
170	49	150	35	075-100-125-150-200	2,35	SR435PI(PE)150□□□*

\*Complete the code by inserting the value of the radius (R): Ex. SR435PI(PE)040 □ □ □ □

R	H	N	M
mm	mm	mm	mm
075	199	155	340
100	249	175	415
125	299	200	495
150	349	230	575
200	449	275	730



### Self-Supporting Capacity Diagram

The maximum length of the self-supporting capacity ( $\frac{LS}{2}$ ) in relationship to the weight of the cables and hoses contained per linear metre.

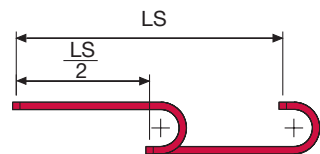
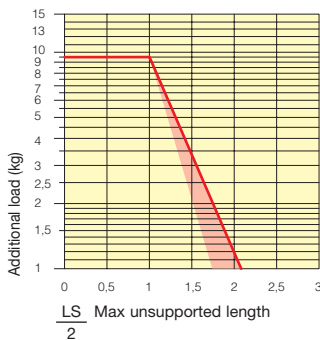

The red marking in the diagram area considers the difference of weight between various widths of chain.

For applications with  $\frac{LS}{2}$  and weights not included in the area of the diagram showing self-supporting capacity, verify the possible use of support rollers (see page 30).

### End Brackets

The end brackets set allows the two ends of the chain to be attached to the equipment. Set complete with tiewrap clamps available on request.

#### Nylon Type

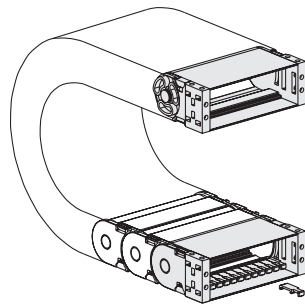
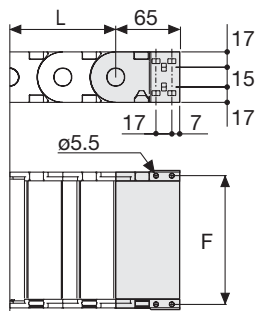

Fig. A  
The chain can be fixed frontally, inner or outer radius. (Fig A)



Chain Type	F mm
SR435PI(PE)040	51
SR435PI(PE)050	61
SR435PI(PE)060	71
SR435PI(PE)076	87
SR435PI(PE)103	114
SR435PI(PE)125	136
SR435PI(PE)150	161

#### Nylon Type Part Numbers

Complete Set Assembled Chain Type	End Brackets Set
SR435...	AN435P□□□*KM

Complete Set Unassembled Chain Type	End Brackets Set
SR435...	AN435P□□□*K

#### Tiewrap Clamp

Part Number
Assembl. SFC435M□□□*KM
Unassembl. SFC435M□□□*K

\* Complete the code by inserting the value of the quote C.

#### Bright Zinc Plated Steel Type\*

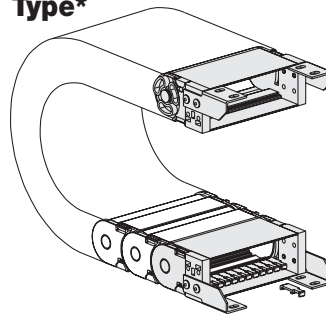
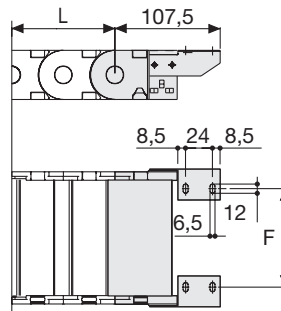

Fig. B  
Chain fixed outside the radius. (Fig B)  
See end brackets mounting variations page 31.



Chain Type	F mm
SR435PI(PE)040	30
SR435PI(PE)050	40
SR435PI(PE)060	50
SR435PI(PE)076	66
SR435PI(PE)103	93
SR435PI(PE)125	115
SR435PI(PE)150	140

#### Bright Zinc Plated Steel Type Part Numbers

Complete Set Assembled Chain Type	End Brackets Set
SR435...	A435P□□□KM□**

Complete Set Unassembled Chain Type	End Brackets Set
SR435...	A435P□□□K□**

\*Available on request in stainless steel  
\*\* 1=Pos.1; 2=Pos.2; 3=Pos.3  
See end brackets mounting variations page 31.

### Serie Protection

## SR435PI

## SR435PE

Nylon Protection Cable Chain with openable covers

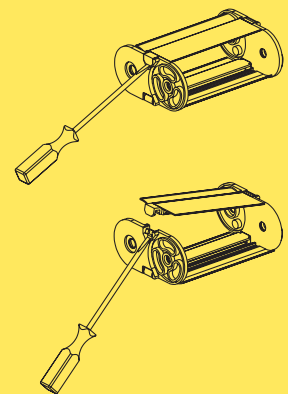

How to open the cover.

Special tool to remove the connecting pivots:  
Part Number PZ010.



For further information please consult Brevetti Stendalto's Technical Office

# Serie Protection

## SR445PI/SR445PE Nylon Protection Cable Chain with openable covers

### Inner height (D) 45 mm

Sideband & Frame construction with large anti-friction single-pin.

Covers are openable from inner radius (SR445PI) or from outer radius (SR445PE).

Vertical separators are available.

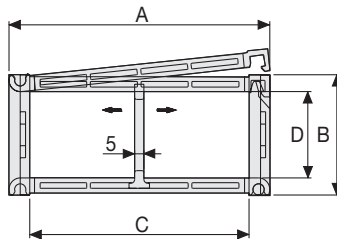

### Separator

- Unassembled	Part.no S445C
- Assembled	Part.no S445CMC

### Pin

Part.no PG445

### Technical characteristics when self-supported

Speed	10 m/s
Acceleration	50 m/s <sup>2</sup>

For higher requirements please consult our technical dept.

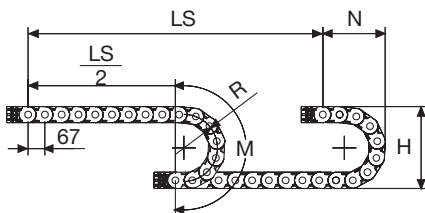

Length of chain (L)

Half travel distance ( $\frac{LS}{2}$ )

plus length of curve (M)

$$L = \frac{LS}{2} + M$$

A	B	C	D	R	Weight/m	Chain
mm	mm	mm	mm	mm	kg	Part Number
72	64	50	45	100-125-150-200-250-300	1,83	SR445PI(PE)050□□□*
83	64	61	45	100-125-150-200-250-300	1,87	SR445PI(PE)061□□□*
97	64	75	45	100-125-150-200-250-300	2,05	SR445PI(PE)075□□□*
103	64	81	45	100-125-150-200-250-300	2,10	SR445PI(PE)081□□□*
117	64	95	45	100-125-150-200-250-300	2,23	SR445PI(PE)095□□□*
122	64	100	45	100-125-150-200-250-300	2,26	SR445PI(PE)100□□□*
129	64	107	45	100-125-150-200-250-300	2,31	SR445PI(PE)107□□□*
139	64	117	45	100-125-150-200-250-300	2,38	SR445PI(PE)117□□□*
147	64	125	45	100-125-150-200-250-300	2,49	SR445PI(PE)125□□□*
158	64	136	45	100-125-150-200-250-300	2,60	SR445PI(PE)136□□□*
172	64	150	45	100-125-150-200-250-300	2,71	SR445PI(PE)150□□□*
197	64	175	45	100-125-150-200-250-300	2,93	SR445PI(PE)175□□□*
222	64	200	45	100-125-150-200-250-300	3,17	SR445PI(PE)200□□□*
233	64	211	45	100-125-150-200-250-300	3,26	SR445PI(PE)211□□□*
247	64	225	45	100-125-150-200-250-300	3,39	SR445PI(PE)225□□□*
274	64	252	45	100-125-150-200-250-300	3,64	SR445PI(PE)252□□□*
283	64	261	45	100-125-150-200-250-300	3,71	SR445PI(PE)261□□□*
334	64	312	45	100-125-150-200-250-300	4,13	SR445PI(PE)312□□□*
356	64	334	45	100-125-150-200-250-300	4,35	SR445PI(PE)334□□□*
384	64	362	45	100-125-150-200-250-300	4,59	SR445PI(PE)362□□□*

\*Complete the code by inserting the value of the radius (R): Ex. SR445PI(PE)050 □ □ □ □

R	H	N	M
mm	mm	mm	mm
100	264	200	450
125	314	225	530
150	364	250	605
200	464	300	765
250	564	350	920
300	664	400	1080



### Self-Supporting Capacity Diagram

The maximum length of the self-supporting capacity ( $\frac{LS}{2}$ ) in relationship to the weight of the cables and hoses contained per linear metre.

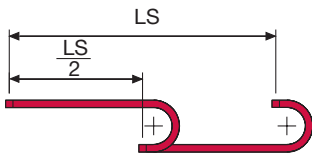
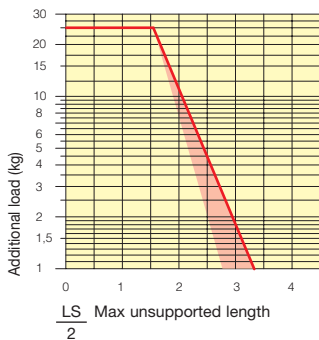

The red marking in the diagram area considers the difference of weight between various widths of chain.

For applications with  $\frac{LS}{2}$  and weights not included in the area of the diagram showing self-supporting capacity, verify the possible use of support rollers (see page 30).

### End Brackets

The end brackets set allows the two ends of the chain to be attached to the equipment.

#### Nylon Type

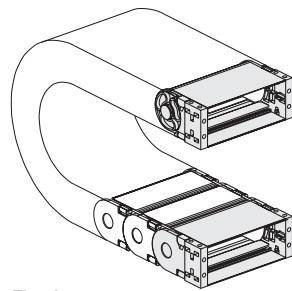
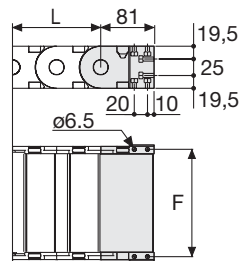

Fig. A  
The chain can be fixed frontally, inner or outer radius. (Fig A)



Chain Type	F mm
SR445PI(PE)050	63
SR445PI(PE)061	74
SR445PI(PE)075	88
SR445PI(PE)081	94
SR445PI(PE)095	108
SR445PI(PE)100	113
SR445PI(PE)107	120
SR445PI(PE)117	130
SR445PI(PE)125	138
SR445PI(PE)136	149
SR445PI(PE)150	163
SR445PI(PE)175	188
SR445PI(PE)200	213
SR445PI(PE)211	224
SR445PI(PE)225	238
SR445PI(PE)252	265
SR445PI(PE)261	274
SR445PI(PE)312	325
SR445PI(PE)334	347
SR445PI(PE)362	375

#### Nylon Type Part Numbers

Complete Set Assembled Chain Type	End Brackets Set
SR445...	AN445P□□□*KM

Complete Set Unassembled Chain Type	End Brackets Set
SR445...	AN445P□□□*K

\* Complete the code by inserting the value of the quote C.

#### Bright Zinc Plated Steel Type\*

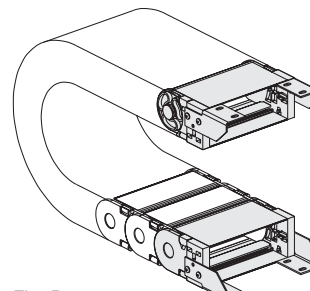
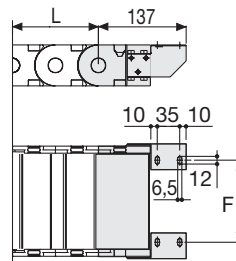

Fig. B  
Chain fixed outside the radius. (Fig B)  
See end brackets mounting variations page 31.



Chain Type	F mm
SR445PI(PE)050	28
SR445PI(PE)061	39
SR445PI(PE)075	53
SR445PI(PE)081	59
SR445PI(PE)095	73
SR445PI(PE)100	78
SR445PI(PE)107	85
SR445PI(PE)117	95
SR445PI(PE)125	103
SR445PI(PE)136	114
SR445PI(PE)150	128
SR445PI(PE)175	153
SR445PI(PE)200	178
SR445PI(PE)211	189
SR445PI(PE)225	203
SR445PI(PE)252	230
SR445PI(PE)261	239
SR445PI(PE)312	290
SR445PI(PE)334	312
SR445PI(PE)362	340

#### Bright Zinc Plated Steel Type Part Numbers

Complete Set Assembled Chain Type	End Brackets Set
SR445...	A445P□□□KM□**

Complete Set Unassembled Chain Type	End Brackets Set
SR445...	A445P□□□K□**

\*Available on request in stainless steel  
\*\* 1=Pos.1; 2=Pos.2; 3=Pos.3  
See end brackets mounting variations page 31.

### Serie Protection

## SR445PI SR445PE

Nylon Protection Cable Chain  
with openable covers

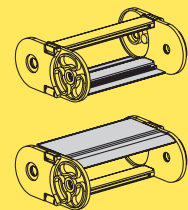

On request available with covers on only internal radius or external radius.

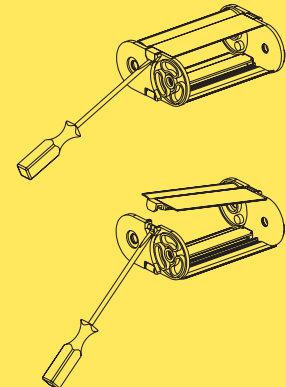

How to open the cover.

#### Protection version



Protection version see page 118

# Serie Protection

## SR445AI/SR445AE Nylon Protection Cable Chain with openable aluminium covers

### Inner height (D) 45 mm

Sideband & Frame construction with large anti-friction single-pin.

Covers are openable from inner radius (SR445AI) or from outer radius (SR445AE).

Vertical separators are available.

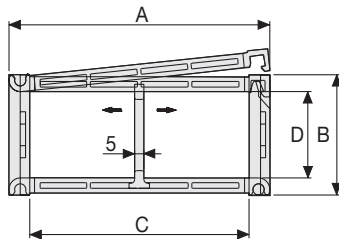

### Separator

- Unassembled	Part.no S445C
- Assembled	Part.no S445CMC

### Pin

Part.no PG445

### Technical characteristics when self-supported

Speed	10 m/s
Acceleration	50 m/s <sup>2</sup>

For higher requirements please consult our technical dept.

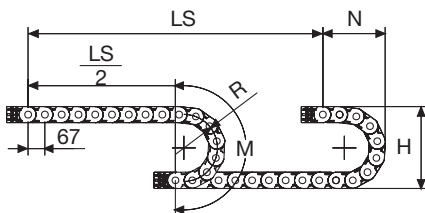

Length of chain (L)

Half travel distance ( $\frac{LS}{2}$ )

plus length of curve (M)

$$L = \frac{LS}{2} + M$$

A	B	C	D	R	Weight/m	Chain
mm	mm	mm	mm	mm	kg	Part Number
72	64	50	45	100-125-150-200-250-300	2,13	SR445AI(AE)050□□□*
83	64	61	45	100-125-150-200-250-300	2,24	SR445AI(AE)061□□□*
97	64	75	45	100-125-150-200-250-300	2,49	SR445AI(AE)075□□□*
103	64	81	45	100-125-150-200-250-300	2,59	SR445AI(AE)081□□□*
117	64	95	45	100-125-150-200-250-300	2,79	SR445AI(AE)095□□□*
122	64	100	45	100-125-150-200-250-300	2,85	SR445AI(AE)100□□□*
129	64	107	45	100-125-150-200-250-300	2,95	SR445AI(AE)107□□□*
139	64	117	45	100-125-150-200-250-300	3,08	SR445AI(AE)117□□□*
147	64	125	45	100-125-150-200-250-300	3,24	SR445AI(AE)125□□□*
158	64	136	45	100-125-150-200-250-300	3,41	SR445AI(AE)136□□□*
172	64	150	45	100-125-150-200-250-300	3,61	SR445AI(AE)150□□□*
197	64	175	45	100-125-150-200-250-300	3,97	SR445AI(AE)175□□□*
222	64	200	45	100-125-150-200-250-300	4,35	SR445AI(AE)200□□□*
233	64	211	45	100-125-150-200-250-300	4,51	SR445AI(AE)211□□□*
247	64	225	45	100-125-150-200-250-300	4,73	SR445AI(AE)225□□□*
274	64	252	45	100-125-150-200-250-300	5,13	SR445AI(AE)252□□□*
283	64	261	45	100-125-150-200-250-300	5,26	SR445AI(AE)261□□□*
334	64	312	45	100-125-150-200-250-300	6,00	SR445AI(AE)312□□□*
356	64	334	45	100-125-150-200-250-300	6,33	SR445AI(AE)334□□□*
384	64	362	45	100-125-150-200-250-300	6,73	SR445AI(AE)362□□□*

\*Complete the code by inserting the value of the radius (R): Ex. SR445AI(AE)050 □ □ □ □

R	H	N	M
mm	mm	mm	mm
100	264	200	450
125	314	225	530
150	364	250	605
200	464	300	765
250	564	350	920
300	664	400	1080

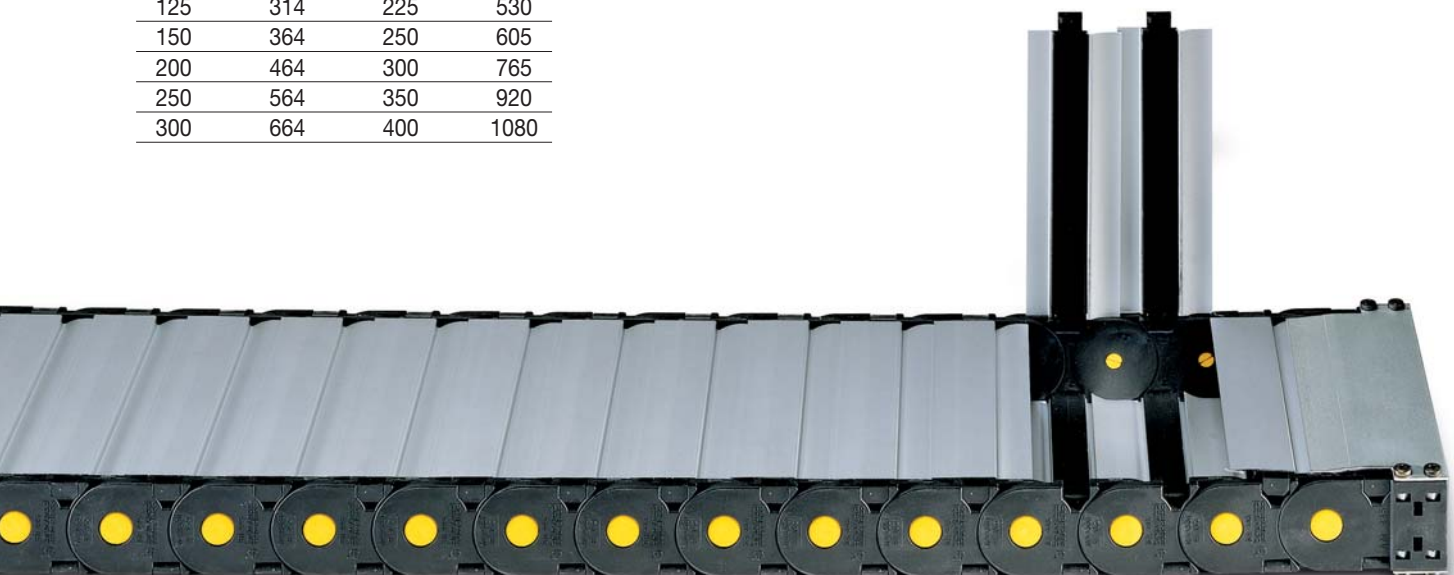

### Self-Supporting Capacity Diagram

The maximum length of the self-supporting capacity ( $\frac{LS}{2}$ ) in relationship to the weight of the cables and hoses contained per linear metre.

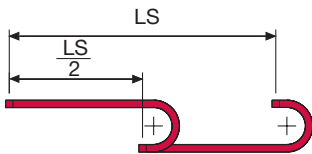
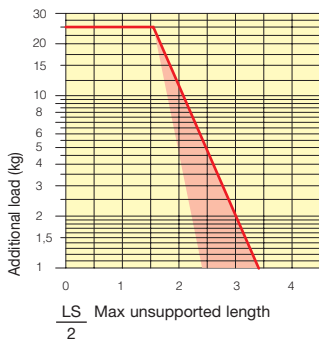

The red marking in the diagram area considers the difference of weight between various widths of chain.

For applications with  $\frac{LS}{2}$  and weights not included in the area of the diagram showing self-supporting capacity, verify the possible use of support rollers (see page 30).

### End Brackets

The end brackets set allows the two ends of the chain to be attached to the equipment.

#### Nylon Type

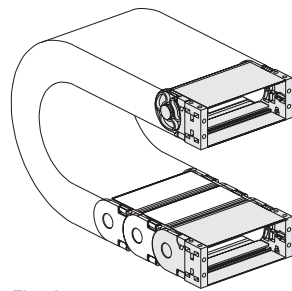
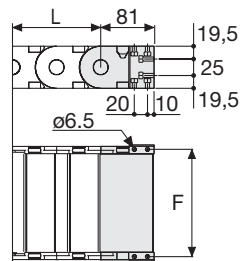

Fig. A  
The chain can be fixed frontally, inner or outer radius. (Fig A)



Chain Type	F mm
SR445AI(AE)050	63
SR445AI(AE)061	74
SR445AI(AE)075	88
SR445AI(AE)081	94
SR445AI(AE)095	108
SR445AI(AE)100	113
SR445AI(AE)107	120
SR445AI(AE)117	130
SR445AI(AE)125	138
SR445AI(AE)136	149
SR445AI(AE)150	163
SR445AI(AE)175	188
SR445AI(AE)200	213
SR445AI(AE)211	224
SR445AI(AE)225	238
SR445AI(AE)252	265
SR445AI(AE)261	274
SR445AI(AE)312	325
SR445AI(AE)334	347
SR445AI(AE)362	375

#### Nylon Type Part Numbers

Complete Set Assembled	
Chain	End Brackets
Type	Set
SR445...	AN445A□□□*KM

Complete Set Unassembled	
Chain	End Brackets
Type	Set
SR445...	AN445A□□□*K

\* Complete the code by inserting the value of the quote C.

#### Bright Zinc Plated Steel Type\*

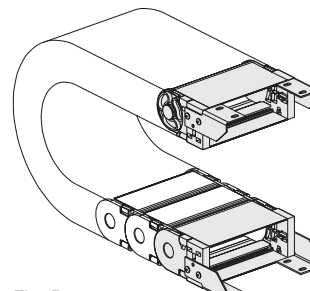
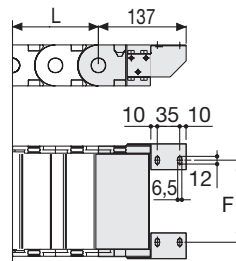

Fig. B  
Chain fixed outside the radius. (Fig B)  
See end brackets mounting variations page 31.



Chain Type	F mm
SR445AI(AE)050	28
SR445AI(AE)061	39
SR445AI(AE)075	53
SR445AI(AE)081	59
SR445AI(AE)095	73
SR445AI(AE)100	78
SR445AI(AE)107	85
SR445AI(AE)117	95
SR445AI(AE)125	103
SR445AI(AE)136	114
SR445AI(AE)150	128
SR445AI(AE)175	153
SR445AI(AE)200	178
SR445AI(AE)211	189
SR445AI(AE)225	203
SR445AI(AE)252	230
SR445AI(AE)261	239
SR445AI(AE)312	290
SR445AI(AE)334	312
SR445AI(AE)362	340

#### Bright Zinc Plated Steel Type Part Numbers

Complete Set Assembled	
Chain	End Brackets
Type	Set
SR445...	A445A□□□KM□**

Complete Set Unassembled	
Chain	End Brackets
Type	Set
SR445...	A445A□□□K□**

\*Available on request in stainless steel  
\*\* 1=Pos.1; 2=Pos.2; 3=Pos.3

See end brackets mounting variations page 31.

### Serie Protection

## SR445AI SR445AE

Nylon Protection Cable Chain with openable aluminium covers



For further information please consult Brevetti Stendalto's Technical Office

# Serie Protection

## SR475PI/SR475PE Nylon Protection Cable Chain with openable covers

### Inner height (D) 75,5 mm

Sideband & Frame construction with large anti-friction single-pin.  
Covers are openable from inner radius (475PI) or from outer radius (475PE).  
Vertical and horizontal modular separator system is available.

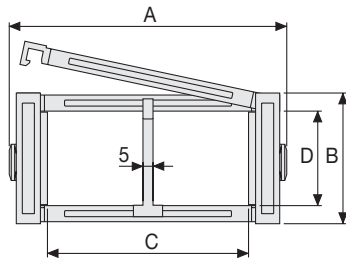

### Separator

- Unassembled	Part.no S309S
- Assembled	Part.no S309SMC

### Pin

Part.no PG475

### Technical characteristics when self-supported

Speed	8 m/s
Acceleration	40 m/s <sup>2</sup>

For higher requirements please consult our technical dept.

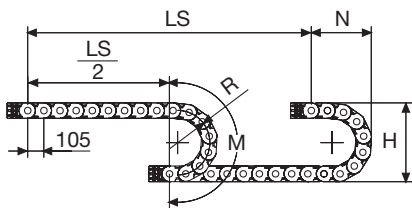

Length of chain (L)

Half travel distance ( $\frac{LS}{2}$ )  
plus length of curve (M)

$$L = \frac{LS}{2} + M$$

A	B	C	D	R	Weight/m	Chain
mm	mm	mm	mm	mm	kg	Part Number
112	100,5	74	75,5	180-200-250-300-350-400	4,60	SR475PI(PE)074□□□*
132	100,5	94	75,5	180-200-250-300-350-400	4,80	SR475PI(PE)094□□□*
157	100,5	119	75,5	180-200-250-300-350-400	5,10	SR475PI(PE)119□□□*
164	100,5	126	75,5	180-200-250-300-350-400	5,15	SR475PI(PE)126□□□*
187	100,5	149	75,5	180-200-250-300-350-400	5,40	SR475PI(PE)149□□□*
227	100,5	189	75,5	180-200-250-300-350-400	5,80	SR475PI(PE)189□□□*
262	100,5	224	75,5	180-200-250-300-350-400	6,20	SR475PI(PE)224□□□*
288	100,5	250	75,5	180-200-250-300-350-400	6,50	SR475PI(PE)250□□□*
312	100,5	274	75,5	180-200-250-300-350-400	6,75	SR475PI(PE)274□□□*
338	100,5	300	75,5	180-200-250-300-350-400	7,05	SR475PI(PE)300□□□*
362	100,5	324	75,5	180-200-250-300-350-400	7,30	SR475PI(PE)324□□□*
388	100,5	350	75,5	180-200-250-300-350-400	7,55	SR475PI(PE)350□□□*
412	100,5	374	75,5	180-200-250-300-350-400	7,85	SR475PI(PE)374□□□*
536	100,5	498	75,5	180-200-250-300-350-400	9,20	SR475PI(PE)498□□□*

\*Complete the code by inserting the value of the radius (R): Ex. SR475PI(PE)119 □ □ □ □

R	H	N	M
mm	mm	mm	mm
180	460,5	335	775
200	500,5	355	840
250	600,5	405	995
300	700,5	460	1155
350	800,5	505	1310
400	900,5	560	1470





### Self-Supporting Capacity Diagram

The maximum length of the self-supporting capacity ( $\frac{LS}{2}$ ) in relationship to the weight of the cables and hoses contained per linear metre.

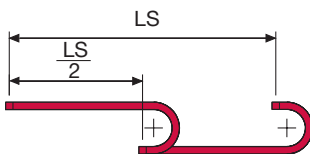
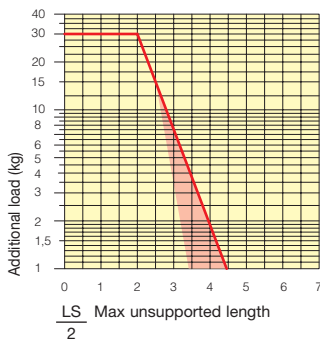

The red marking in the diagram area considers the difference of weight between various widths of chain.

For applications with  $\frac{LS}{2}$  and weights not included in the area of the diagram showing self-supporting capacity, verify the possible use of support rollers (see page 30).

### Bright Zinc Plated Steel End Brackets\*

The end brackets set allows the two ends of the chain to be attached to the equipment.

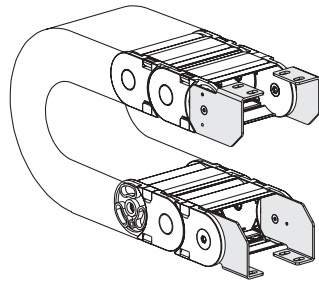
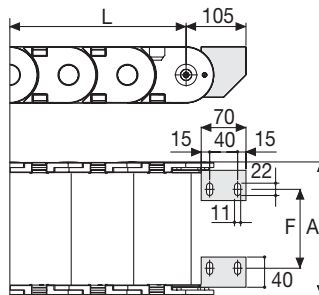

Fig. A  
Chain fixed outside the radius. (Fig A)  
See end brackets mounting variations page 31.



Chain Type	F mm
SR475PI(PE)074	35
SR475PI(PE)094	55
SR475PI(PE)119	80
SR475PI(PE)126	87
SR475PI(PE)149	110
SR475PI(PE)189	150
SR475PI(PE)224	185
SR475PI(PE)250	211
SR475PI(PE)274	235
SR475PI(PE)300	261
SR475PI(PE)324	285
SR475PI(PE)350	311
SR475PI(PE)374	335
SR475PI(PE)498	459

### Bright Zinc Plated Steel Type Part Numbers

Complete Set Assembled	Chain	End Brackets
Type	Set	Set
SR475...	A475P	□□□KM□**

Complete Set Unassembled	Chain	End Brackets
Type	Set	Set
SR475...	A475P	□□□K□**

\*Available on request in stainless steel  
\*\* 1=Pos.1; 2=Pos.2; 3=Pos.3  
See end brackets mounting variations page 31.

### Serie Protection

## SR475PI SR475PE

Nylon Protection Cable Chain  
with openable covers

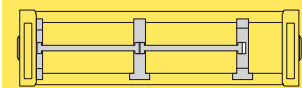

Separation System  
To choose the separators see page. 176

3

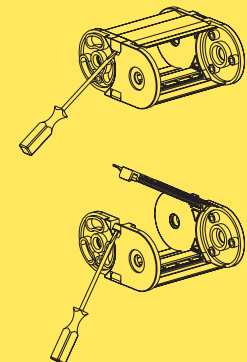

How to open the cover.

For further information please consult Brevetti Stendalto's Technical Office

# Serie Protection

## SR660

### Nylon Protection Cable Chain with openable covers

#### Inner height (D) 36 mm

Double share Sideband & Frame construction with large anti-friction single-pin. Covers are openable from inner radius.

Vertical separators are available.

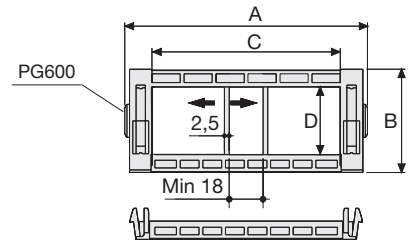
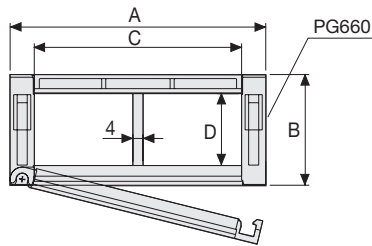

#### Separator

- Unassembled Part.no S660
- Assembled Part.no S660MC

#### Separator

- Unassembled Part.no S600
- Assembled Part.no S600MC

#### Technical characteristics when self-supported

Speed	6 m/s
Acceleration	30 m/s <sup>2</sup>

For higher requirements please consult our technical dept.

A	B	C	D	R	Weight/m	Chain
mm	mm	mm	mm	mm	kg	Part Number
79	55	50	36	100-150-200-250	1,90	SR660050□□□*
129	55	100	36	100-150-200-250	2,40	SR660100□□□*
179	55	150	36	100-150-200-250	3,00	SR66015□□**

\*Complete the code by inserting the value of the radius (R): Ex. SR660050 [1][5][0]

\*\*Complete the code by inserting the value of the radius (R): Ex. SR66015 [1]

Where: 0=100; 1=150; 2=200; 3=250

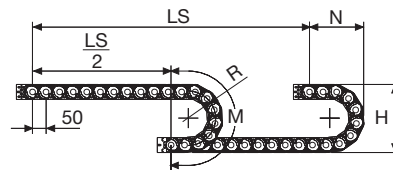

R	H	N	M
mm	mm	mm	mm
100	255	180	415
150	355	230	575
200	455	280	730
250	555	330	885

Length of chain (L)

Half travel distance ( $\frac{LS}{2}$ )  
plus length of curve (M)

$$L = \frac{LS}{2} + M$$



### Self-Supporting Capacity Diagram

The maximum length of the self-supporting capacity ( $\frac{LS}{2}$ ) in relationship to the weight of the cables and hoses contained per linear metre.

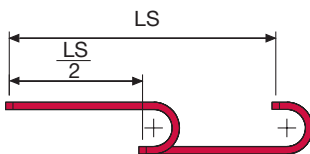
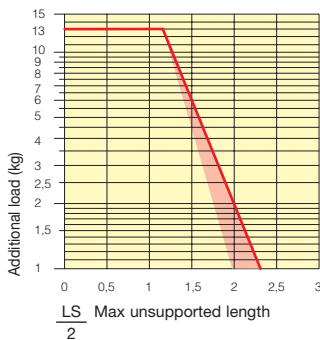

The red marking in the diagram area considers the difference of weight between various widths of chain.

For applications with  $\frac{LS}{2}$  and weights not included in the area of the diagram showing self-supporting capacity, verify the possible use of support rollers (see page 30).

### End Brackets

The end brackets set allows the two ends of the chain to be attached to the equipment.

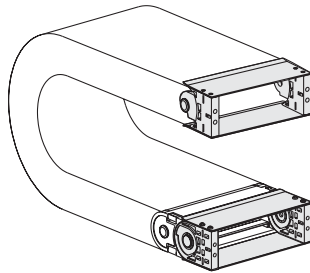
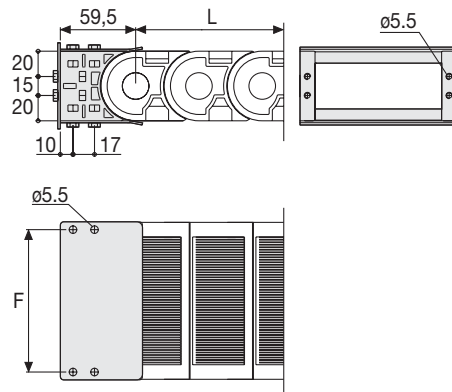

Fig. A  
The chain can be fixed frontally, inner or outer radius. (Fig A)



Chain Type	F mm
SR660 C=50	62
SR660 C=100	112
SR600 C=150	162

### Nylon Type Part Numbers

Complete Set Assembled	
Chain Type	End Brackets Set
SR660 C=50	AN660050KM
SR660 C=100	AN660100KM
SR600 C=150	AL600KM

Complete Set Unassembled	
Chain Type	End Brackets Set
SR660 C=50	AN660050K
SR660 C=100	AN660100K
SR600 C=150	AL600K

### Serie Protection

## SR660

Nylon Protection Cable Chain  
with openable covers

3

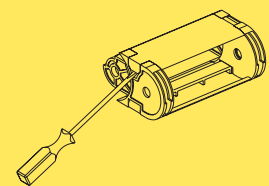
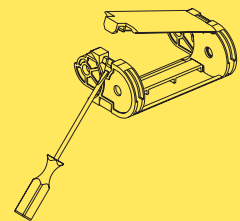

How to open the cover.

Special tool to remove the connecting pivots:  
Part Number PZ010.



For further information please consult Brevetti Stendalto's Technical Office

# Serie Protection

## SR770

### Nylon Protection Cable Chain with openable covers

#### Inner height (D) 51 mm

Double share Sideband & Frame construction with large anti-friction single-pin. Covers are openable from inner radius.

Vertical separators are available.

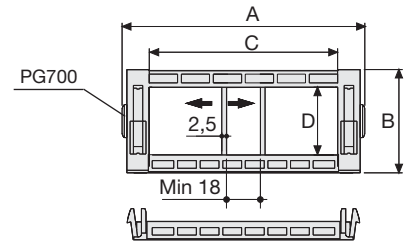
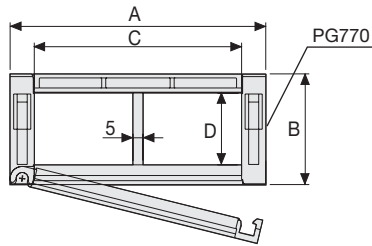

#### Separator

- Unassembled Part.no S770
- Assembled Part.no S770MC

#### Separator

- Unassembled Part.no S700
- Assembled Part.no S700MC

#### Technical characteristics when self-supported

Speed	6 m/s
Acceleration	30 m/s <sup>2</sup>

For higher requirements please consult our technical dept.

A	B	C	D	R	Weight/m	Chain
mm	mm	mm	mm	mm	kg	Part Number
120	78	85	51	150-200-250-300	3,30	SR770085□□□*
135	78	100	51	150-200-250-300	3,90	SR770100□□□*
185	78	150	51	150-200-250-300	4,10	SR770150□□□*
235	78	200	51	150-200-250-300	4,50	SR770200□□□*
285	78	250	51	150-200-250-300	5,00	SR770250□□□**

\*Complete the code by inserting the value of the radius (R): Ex. SR770085 [7][5][0]

\*\*Complete the code by inserting the value of the radius (R): Ex. SR770250 [7]

Where: 0=150; 1=200; 2=250; 3=300

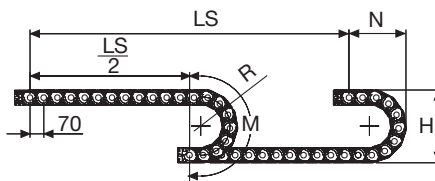

R	H	N	M
mm	mm	mm	mm
150	378	260	615
200	478	310	770
250	578	365	930
300	678	410	1085

Length of chain (L)

Half travel distance ( $\frac{LS}{2}$ )  
plus length of curve (M)

$$L = \frac{LS}{2} + M$$



### Self-Supporting Capacity Diagram

The maximum length of the self-supporting capacity ( $\frac{LS}{2}$ ) in relationship to the weight of the cables and hoses contained per linear metre.

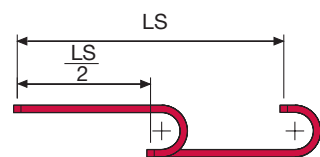
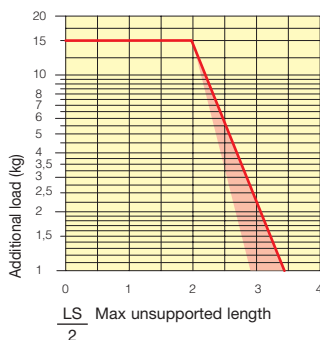

The red marking in the diagram area considers the difference of weight between various widths of chain.

For applications with  $\frac{LS}{2}$  and weights not included in the area of the diagram showing self-supporting capacity, verify the possible use of support rollers (see page 30).

### End Brackets

The end brackets set allows the two ends of the chain to be attached to the equipment.

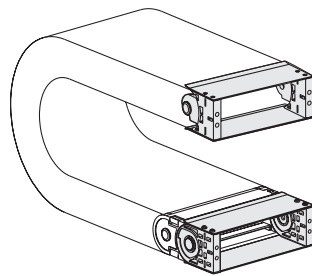
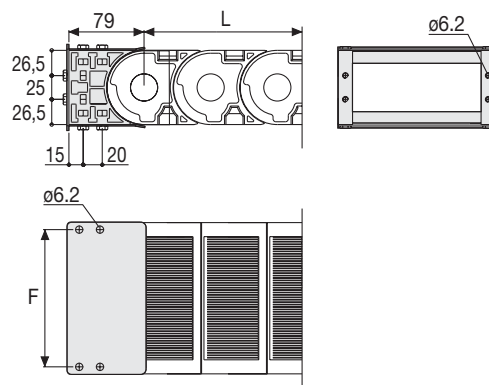

Fig. A  
The chain can be fixed frontally, inner or outer radius. (Fig A)



Chain Type	F mm
SR770 C=85	100
SR770 C=100	115
SR770 C=150	165
SR770 C=200	215
SR700 C=250	265

### Nylon Type Part Numbers

Complete Set Assembled Chain Type	End Brackets Set
SR770...	AN770□□□*KM
SR700 C=250	AL700KM

Complete Set Unassembled Chain Type	End Brackets Set
SR770...	AN770□□□*K
SR700 C=250	AL700K

\* Complete the code by inserting the value of the quote C.

### Serie Protection

## SR770

Nylon Protection Cable Chain with openable covers

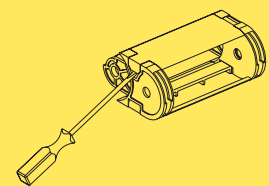
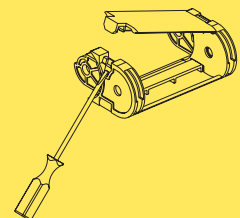

How to open the cover.

Special tool to remove the connecting pivots:  
Part Number PZ010.



For further information please consult Brevetti Stendalto's Technical Office

# Serie Protection

## SR306CI/SR306CE Nylon Protection Cable Chain with openable aluminium covers

### Inner height (D) 37 mm

Strong double share Sideband & Frame construction with large anti-friction triple-pin.

Covers are openable from inner radius (SR306CI) or from outer radius (SR306CE).

Vertical separators are available.

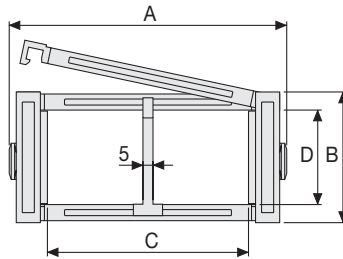

### Separator

- Unassembled	Part.no S306SM
- Assembled	Part.no S306SMMC

### Pin

Part.no PG307

### Technical characteristics when self-supported

Speed	8 m/s
Acceleration	40 m/s <sup>2</sup>

For higher requirements please consult our technical dept.

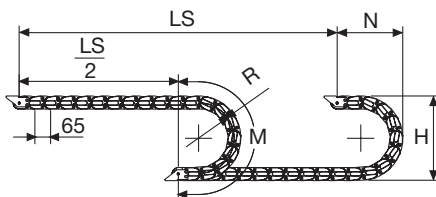

Length of chain (L)

Half travel distance ( $\frac{LS}{2}$ )

plus length of curve (M)

$$L = \frac{LS}{2} + M$$

A	B	C	D	R	Weight/m	Chain
mm	mm	mm	mm	mm	kg	Part Number
79	55	43	37	107-150-200-250-300	1,85	SR306CI(CE)043□□□*
90	55	54	37	107-150-200-250-300	1,90	SR306CI(CE)054□□□*
104	55	68	37	107-150-200-250-300	2,04	SR306CI(CE)068□□□*
110	55	74	37	107-150-200-250-300	2,09	SR306CI(CE)074□□□*
124	55	88	37	107-150-200-250-300	2,20	SR306CI(CE)088□□□*
129	55	93	37	107-150-200-250-300	2,22	SR306CI(CE)093□□□*
136	55	100	37	107-150-200-250-300	2,27	SR306CI(CE)100□□□*
146	55	110	37	107-150-200-250-300	2,33	SR306CI(CE)110□□□*
154	55	118	37	107-150-200-250-300	2,42	SR306CI(CE)118□□□*
165	55	129	37	107-150-200-250-300	2,50	SR306CI(CE)129□□□*
179	55	143	37	107-150-200-250-300	2,61	SR306CI(CE)143□□□*
204	55	168	37	107-150-200-250-300	2,80	SR306CI(CE)168□□□*
229	55	193	37	107-150-200-250-300	3,00	SR306CI(CE)193□□□*
240	55	204	37	107-150-200-250-300	3,08	SR306CI(CE)204□□□*
254	55	218	37	107-150-200-250-300	3,19	SR306CI(CE)218□□□*
281	55	245	37	107-150-200-250-300	3,40	SR306CI(CE)245□□□*
290	55	254	37	107-150-200-250-300	3,47	SR306CI(CE)254□□□*
341	55	305	37	107-150-200-250-300	3,84	SR306CI(CE)305□□□*
363	55	327	37	107-150-200-250-300	4,01	SR306CI(CE)327□□□*
391	55	355	37	107-150-200-250-300	4,22	SR306CI(CE)355□□□*

\*Complete the code by inserting the value of the radius (R): Ex. SR306CI(CE)110 □ □ □ □

R	H	N	M
mm	mm	mm	mm
107	269	205	470
150	355	245	605
200	455	295	760
250	555	345	920
300	655	395	1075

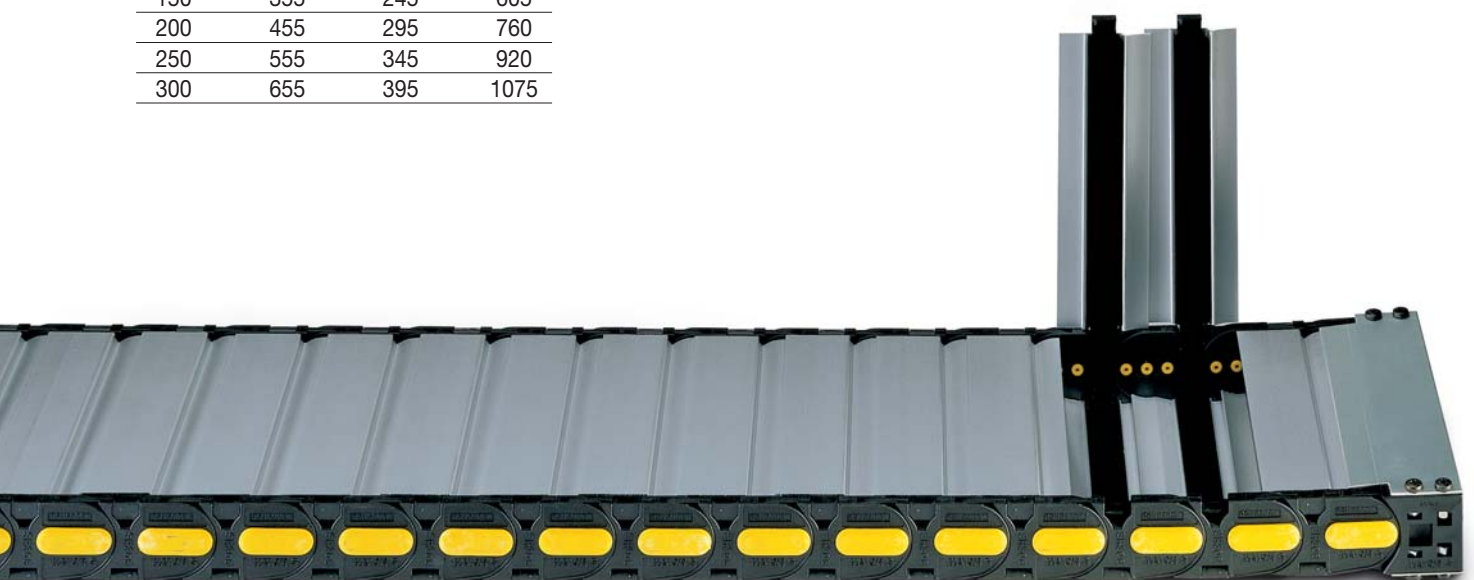

### Self-Supporting Capacity Diagram

The maximum length of the self-supporting capacity ( $\frac{LS}{2}$ ) in relationship to the weight of the cables and hoses contained per linear metre.

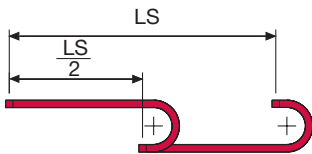
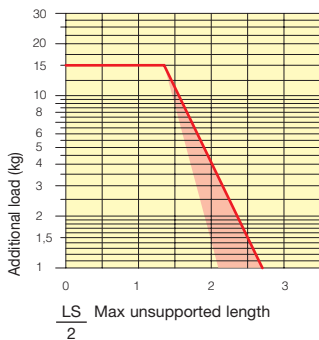

The red marking in the diagram area considers the difference of weight between various widths of chains assembled with nylon frames every second pitch.

For applications with  $\frac{LS}{2}$  and weights not included in the area of the diagram showing self-supporting capacity, verify the possible use of support rollers (see page 30).

### End Brackets

The end brackets set allows the two ends of the chain to be attached to the equipment.

#### Nylon Type

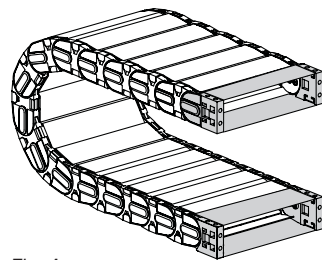

Fig. A  
The chain can be fixed frontally, inner or outer radius. (Fig A)

#### Bright Zinc Plated Steel Type\*

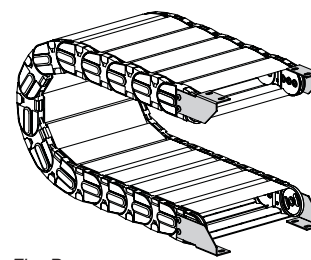
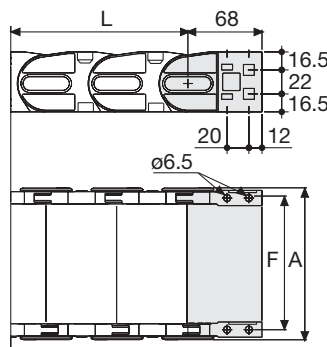

Fig. B  
Chain fixed outside the radius. (Fig B)  
See end brackets mounting variations page 31.



Chain Type	F mm
SR306CI(CE)043	61
SR306CI(CE)054	72
SR306CI(CE)068	86
SR306CI(CE)074	92
SR306CI(CE)088	106
SR306CI(CE)093	111
SR306CI(CE)100	118
SR306CI(CE)110	128
SR306CI(CE)118	136
SR306CI(CE)129	147
SR306CI(CE)143	161
SR306CI(CE)168	186
SR306CI(CE)193	211
SR306CI(CE)204	222
SR306CI(CE)218	236
SR306CI(CE)245	263
SR306CI(CE)254	272
SR306CI(CE)305	323
SR306CI(CE)327	345
SR306CI(CE)355	373

#### Nylon Type Part Numbers

Complete Set Assembled Chain	End Brackets Set
SR306	AN306C□□□KM

Complete Set Unassembled Chain	End Brackets Set
SR306	AN306C□□□K

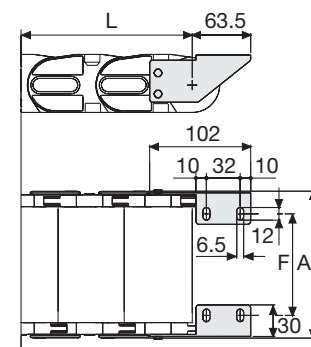

Chain Type	F mm
SR306CI(CE)043	36
SR306CI(CE)054	47
SR306CI(CE)068	61
SR306CI(CE)074	67
SR306CI(CE)088	81
SR306CI(CE)093	86
SR306CI(CE)100	93
SR306CI(CE)110	103
SR306CI(CE)118	111
SR306CI(CE)129	122
SR306CI(CE)143	136
SR306CI(CE)168	161
SR306CI(CE)193	186
SR306CI(CE)204	197
SR306CI(CE)218	211
SR306CI(CE)245	238
SR306CI(CE)254	247
SR306CI(CE)305	298
SR306CI(CE)327	320
SR306CI(CE)355	348

#### Bright Zinc Plated Steel Type Part Numbers

Complete Set Assembled Chain	End Brackets Set
SR306	A306CU□□□KM□**

Complete Set Unassembled Chain	End Brackets Set
SR306	A306CU□□□K□**

\*Available on request in stainless steel  
\*\* 1=Pos.1; 2=Pos.2; 3=Pos.3  
See end brackets mounting variations page 31.

### Serie Protection

## SR306CI SR306CE

Nylon Protection Cable Chain with openable aluminium covers



# Serie Protection

## SR308CI/SR308CE Nylon Protection Cable Chain with openable aluminium covers

### Inner height (D) 57 mm

Strong double share Sideband & Frame construction with large anti-friction triple-pin.

Covers are openable from inner radius (SR308CI) or from outer radius (SR308CE).

Vertical separators are available.

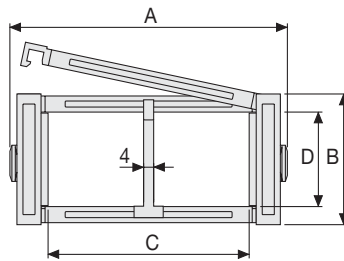

### Separator

- Unassembled	Part.no S308C
- Assembled	Part.no S308CMC

### Pin

Part.no PG308

### Technical characteristics when self-supported

Speed	8 m/s
Acceleration	40 m/s <sup>2</sup>

For higher requirements please consult our technical dept.

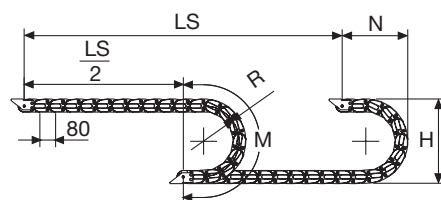

Length of chain (L)

Half travel distance ( $\frac{LS}{2}$ )

plus length of curve (M)

$$L = \frac{LS}{2} + M$$

A	B	C	D	R	Weight/m	Chain
mm	mm	mm	mm	mm	kg	Part Number
82	75	38	57	180-200-230-280-400	2,90	SR308CI(CE)038□□□*
93	75	49	57	180-200-230-280-400	3,01	SR308CI(CE)049□□□*
107	75	63	57	180-200-230-280-400	3,19	SR308CI(CE)063□□□*
113	75	69	57	180-200-230-280-400	3,27	SR308CI(CE)069□□□*
127	75	83	57	180-200-230-280-400	3,43	SR308CI(CE)083□□□*
132	75	88	57	180-200-230-280-400	3,48	SR308CI(CE)088□□□*
139	75	95	57	180-200-230-280-400	3,56	SR308CI(CE)095□□□*
149	75	105	57	180-200-230-280-400	3,67	SR308CI(CE)105□□□*
157	75	113	57	180-200-230-280-400	3,77	SR308CI(CE)113□□□*
168	75	124	57	180-200-230-280-400	3,91	SR308CI(CE)124□□□*
182	75	138	57	180-200-230-280-400	4,06	SR308CI(CE)138□□□*
207	75	163	57	180-200-230-280-400	4,36	SR308CI(CE)163□□□*
232	75	188	57	180-200-230-280-400	4,65	SR308CI(CE)188□□□*
243	75	199	57	180-200-230-280-400	4,78	SR308CI(CE)199□□□*
257	75	213	57	180-200-230-280-400	4,94	SR308CI(CE)213□□□*
284	75	240	57	180-200-230-280-400	5,25	SR308CI(CE)240□□□*
293	75	249	57	180-200-230-280-400	5,37	SR308CI(CE)249□□□*
344	75	300	57	180-200-230-280-400	5,95	SR308CI(CE)300□□□*
366	75	322	57	180-200-230-280-400	6,20	SR308CI(CE)322□□□*
394	75	350	57	180-200-230-280-400	6,11	SR308CI(CE)350□□□*

\*Complete the code by inserting the value of the radius (R): Ex. SR308CI(CE)105 □ □ □ □

R	H	N	M
mm	mm	mm	mm
180	435	300	725
200	475	320	790
230	535	350	885
280	635	400	1040
400	875	520	1420

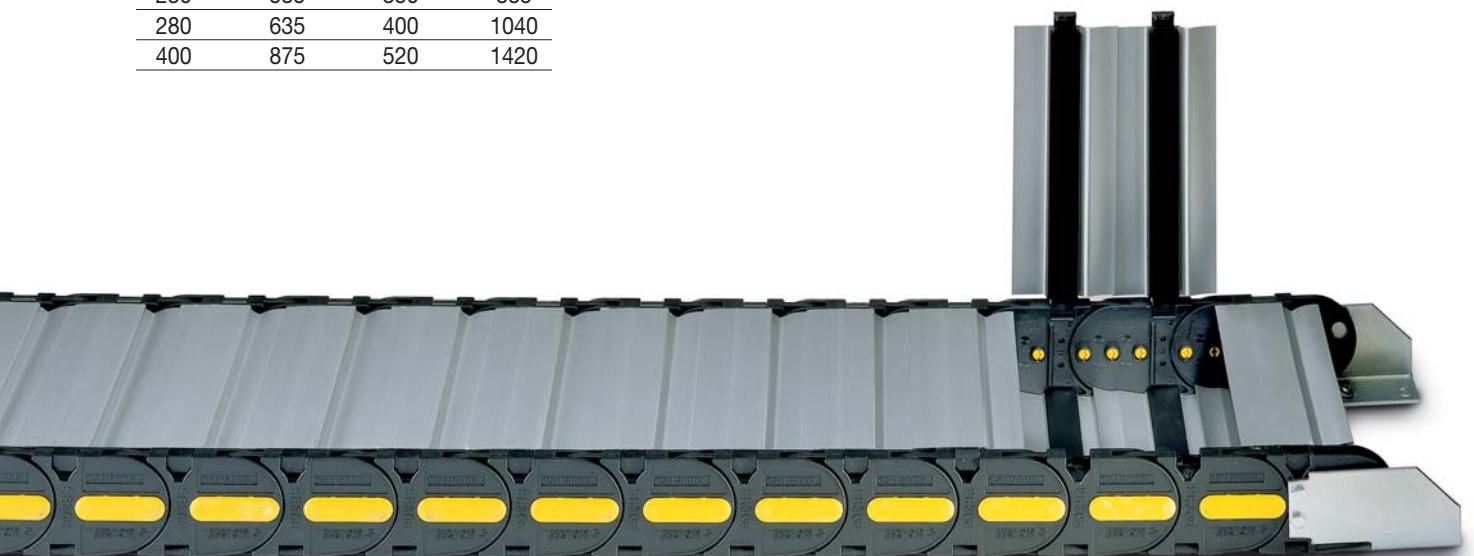



### Self-Supporting Capacity Diagram

The maximum length of the self-supporting capacity ( $\frac{LS}{2}$ ) in relationship to the weight of the cables and hoses contained per linear metre.

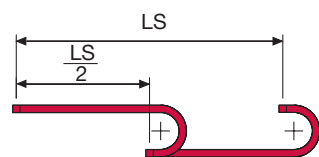
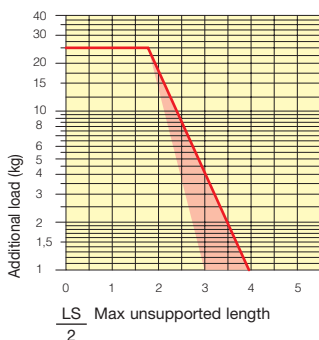

The red marking in the diagram area considers the difference of weight between various widths of chains assembled with nylon frames every second pitch.

For applications with  $\frac{LS}{2}$  and weights not included in the area of the diagram showing self-supporting capacity, verify the possible use of support rollers (see page 30).

### End Brackets

The end brackets set allows the two ends of the chain to be attached to the equipment.

#### Nylon Type

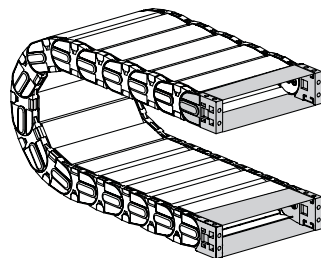

Fig. A  
The chain can be fixed frontally, inner or outer radius. (Fig A)

#### Bright Zinc Plated Steel Type\*

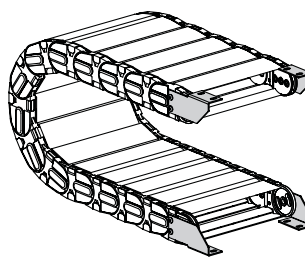
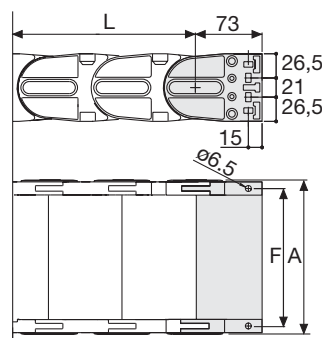

Fig. A  
Chain fixed outside the radius. (Fig A)  
See end brackets mounting variations page 31.



Chain Type	F mm
SR308CI(CE)038	62
SR308CI(CE)049	73
SR308CI(CE)063	87
SR308CI(CE)069	93
SR308CI(CE)083	107
SR308CI(CE)088	112
SR308CI(CE)095	119
SR308CI(CE)105	129
SR308CI(CE)113	137
SR308CI(CE)124	148
SR308CI(CE)138	162
SR308CI(CE)163	187
SR308CI(CE)188	212
SR308CI(CE)199	223
SR308CI(CE)213	237
SR308CI(CE)240	264
SR308CI(CE)249	273
SR308CI(CE)300	324
SR308CI(CE)322	346
SR308CI(CE)350	374

#### Nylon Type Part Numbers

Complete Set Assembled Chain Type	End Brackets Set
SR308	AN308C□□□KM

Complete Set Unassembled Chain Type	End Brackets Set
SR308	AN308C□□□K

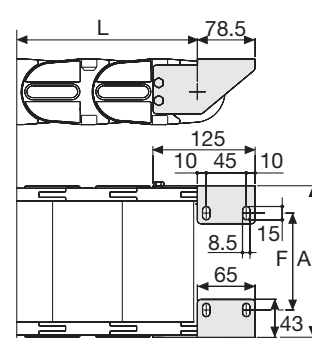

Chain Type	F mm
SR308CI(CE)038	20
SR308CI(CE)049	31
SR308CI(CE)063	45
SR308CI(CE)069	51
SR308CI(CE)083	65
SR308CI(CE)088	70
SR308CI(CE)095	77
SR308CI(CE)105	87
SR308CI(CE)113	95
SR308CI(CE)124	106
SR308CI(CE)138	120
SR308CI(CE)163	145
SR308CI(CE)188	170
SR308CI(CE)199	181
SR308CI(CE)213	195
SR308CI(CE)240	222
SR308CI(CE)249	231
SR308CI(CE)300	282
SR308CI(CE)322	304
SR308CI(CE)350	332

#### Bright Zinc Plated Steel Type Part Numbers

Complete Set Assembled Chain Type	End Brackets Set
SR308	A308CU□□□KM□**

Complete Set Unassembled Chain Type	End Brackets Set
SR308	A308CU□□□K□**

\*Available on request in stainless steel  
\*\* 1=Pos.1; 2=Pos.2; 3=Pos.3  
See end brackets mounting variations page 31.

### Serie Protection

## SR308CI SR308CE

Nylon Protection Cable Chain with openable aluminium covers



For further information please consult Brevetti Stendalto's Technical Office

# Serie Protection

## SR309C

### Nylon Protection Cable Chain with openable covers

#### Inner height (D) 72 mm

Strong double share Sideband & Frame construction with large anti-friction triple-pin.

Covers are openable from outer radius  
Vertical and horizontal separator systems are available.

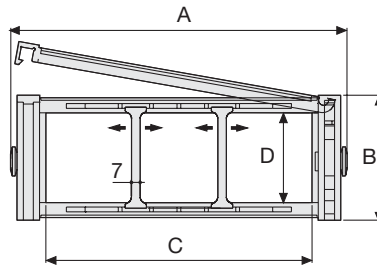

#### Separator

- Unassembled Part.no S309PO  
- Assembled Part.no S309POMC

#### Pin

Part.no PG309

#### Technical characteristics when self-supported

Speed	8 m/s
Acceleration	40 m/s <sup>2</sup>

For higher requirements please consult our technical dept.

A	B	C	D	R	Weight/m	Chain
mm	mm	mm	mm	mm	kg	Part Number
256	100	200	72	200-250-300-350-400-500	5,7	SR309C200□□□*
356	100	300	72	200-250-300-350-400-500	6,8	SR309C300□□□*
456	100	400	72	200-250-300-350-400-500	7,9	SR309C400□□□*

\*Complete the code by inserting the value of the radius (R): Ex. SR309C200 □ □ □ □

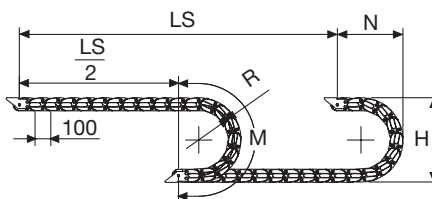

R	H	N	M
mm	mm	mm	mm
200	500	350	830
250	600	400	985
300	700	455	1145
350	800	500	1300
400	900	555	1460
500	1100	650	1770

Length of chain (L)

Half travel distance ( $\frac{LS}{2}$ )  
plus length of curve (M)

$$L = \frac{LS}{2} + M$$



### Self-Supporting Capacity Diagram

The maximum length of the self-supporting capacity ( $\frac{LS}{2}$ ) in relationship to the weight of the cables and hoses contained per linear metre.

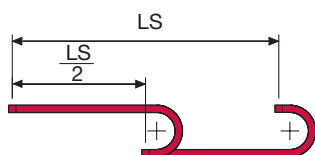
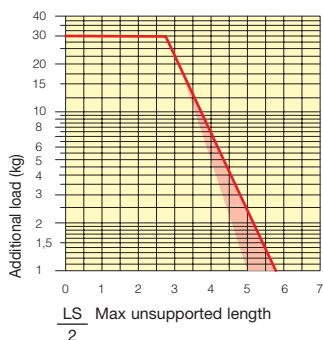

The red marking in the diagram area considers the difference of weight between various widths of chain.

For applications with  $\frac{LS}{2}$  and weights not included in the area of the diagram showing self-supporting capacity, verify the possible use of support rollers (see page 30).

### End Brackets

The end brackets set allows the two ends of the chain to be attached to the equipment.

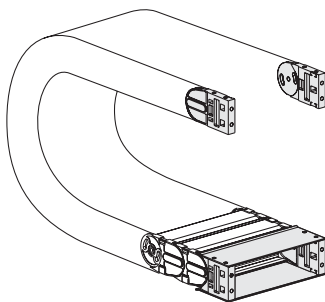
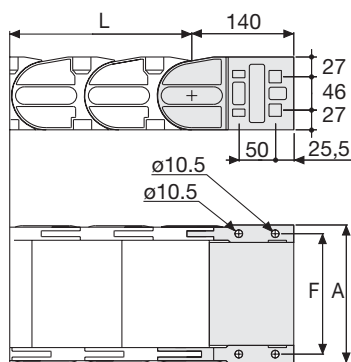

Fig. A  
The chain can be fixed frontally, inner or outer radius. (Fig A)



Chain Type	F mm
SR309C200	229
SR309C300	329
SR309C400	429

### Nylon Type Part Numbers

Complete Set Assembled	
Chain Type	End Brackets Set
SR309C200	AN309C200KM
SR309C300	AN309C300KM
SR309C400	AN309C400KM

Complete Set Unassembled	
Chain Type	End Brackets Set
SR309C200	AN309C200K
SR309C300	AN309C300K
SR309C400	AN309C400K

### Serie Protection

## SR309C

Nylon Protection Cable Chain  
with openable covers

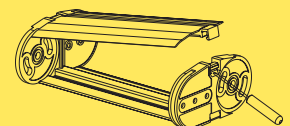
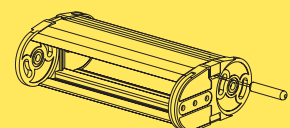

How to open the cover.

For further information please consult Brevetti Stendalto's Technical Office

# Serie Protection

## SR309CI/SR309CE Nylon Protection Cable Chain with openable aluminium covers

### Inner height (D) 75,5 mm

Strong double share Sideband & Frame construction with large anti-friction triple-pin.

Covers are openable from inner radius (SR309CI) or from outer radius (SR309CE).

Vertical separators are available.

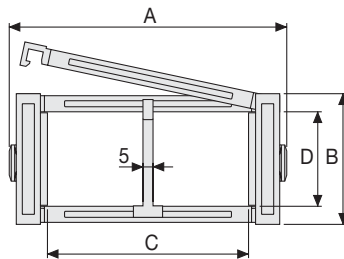

### Separator

- Unassembled	Part.no S309S
- Assembled	Part.no S309SMC

### Pin

Part.no PG309

### Technical characteristics when self-supported

Speed	8 m/s
Acceleration	40 m/s <sup>2</sup>

For higher requirements please consult our technical dept.

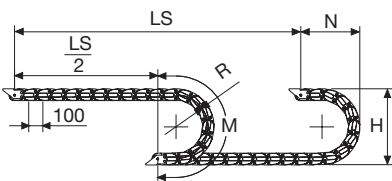

Length of chain (L)

Half travel distance ( $\frac{LS}{2}$ )

plus length of curve (M)

$$L = \frac{LS}{2} + M$$

A	B	C	D	R	Weight/m	Chain
mm	mm	mm	mm	mm	kg	Part Number
120	100	64	75,5	200-250-300-350-400-500	4,84	SR309CI(CE)064□□□*
140	100	84	75,5	200-250-300-350-400-500	5,12	SR309CI(CE)084□□□*
165	100	109	75,5	200-250-300-350-400-500	5,47	SR309CI(CE)109□□□*
172	100	116	75,5	200-250-300-350-400-500	5,58	SR309CI(CE)116□□□*
195	100	139	75,5	200-250-300-350-400-500	5,90	SR309CI(CE)139□□□*
235	100	179	75,5	200-250-300-350-400-500	6,47	SR309CI(CE)179□□□*
270	100	214	75,5	200-250-300-350-400-500	6,97	SR309CI(CE)214□□□*
296	100	240	75,5	200-250-300-350-400-500	7,35	SR309CI(CE)240□□□*
320	100	264	75,5	200-250-300-350-400-500	7,68	SR309CI(CE)264□□□*
346	100	290	75,5	200-250-300-350-400-500	8,04	SR309CI(CE)290□□□*
370	100	314	75,5	200-250-300-350-400-500	8,39	SR309CI(CE)314□□□*
396	100	340	75,5	200-250-300-350-400-500	8,74	SR309CI(CE)340□□□*
420	100	364	75,5	200-250-300-350-400-500	9,09	SR309CI(CE)364□□□*
544	100	488	75,5	200-250-300-350-400-500	10,86	SR309CI(CE)488□□□*

\*Complete the code by inserting the value of the radius (R): Ex. SR309CI(CE)116 [2] [3] [0]

R	H	N	M
mm	mm	mm	mm
200	500	350	830
250	600	400	985
300	700	455	1145
350	800	500	1300
400	900	555	1460
500	1100	650	1770

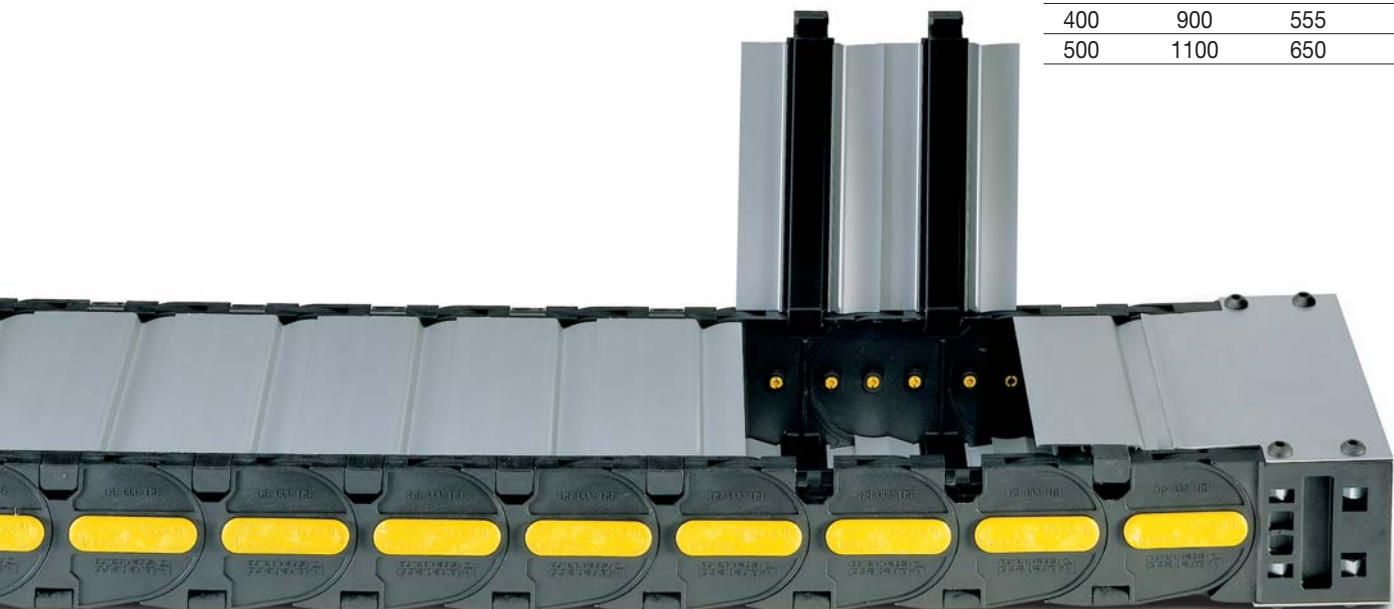

### Self-Supporting Capacity Diagram

The maximum length of the self-supporting capacity ( $\frac{LS}{2}$ ) in relationship to the weight of the cables and hoses contained per linear metre.

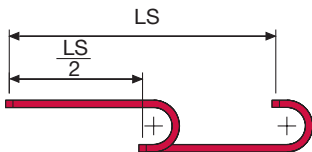
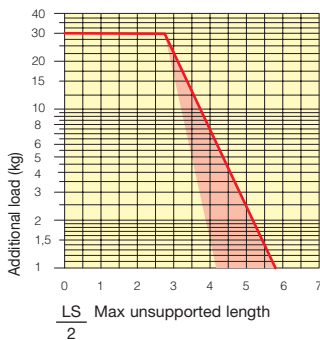

The red marking in the diagram area considers the difference of weight between various widths of chains assembled with nylon frames every second pitch.

For applications with  $\frac{LS}{2}$  and weights not included in the area of the diagram showing self-supporting capacity, verify the possible use of support rollers (see page 30).

### End Brackets

The end brackets set allows the two ends of the chain to be attached to the equipment.

#### Nylon Type

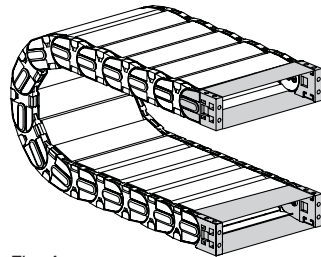

Fig. A  
The chain can be fixed frontally, inner or outer radius. (Fig A)

#### Bright Zinc Plated Steel Type\*

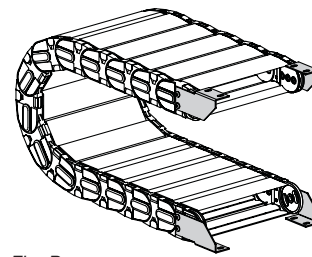
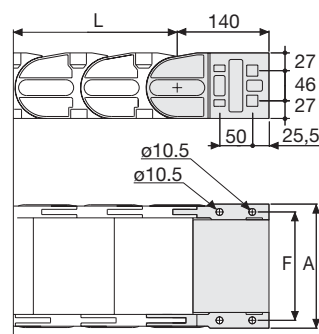

Fig. B  
Chain fixed outside the radius. (Fig B)  
See end brackets mounting variations page 31.



Chain Type	F mm
SR309CI(CE)064	92
SR309CI(CE)084	112
SR309CI(CE)109	137
SR309CI(CE)116	144
SR309CI(CE)139	167
SR309CI(CE)179	207
SR309CI(CE)214	242
SR309CI(CE)240	268
SR309CI(CE)264	292
SR309CI(CE)290	318
SR309CI(CE)314	342
SR309CI(CE)340	368
SR309CI(CE)364	392
SR309CI(CE)488	516

#### Nylon Type Part Numbers

Complete Set Assembled Chain Type	End Brackets Set
SR309	AN309C□□□KM

Complete Set Unassembled Chain Type	End Brackets Set
SR309	AN309C□□□K

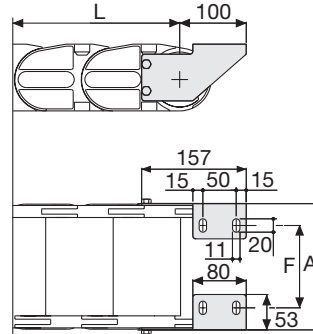

Chain Type	F mm
SR309CI(CE)064	50
SR309CI(CE)084	70
SR309CI(CE)109	95
SR309CI(CE)116	102
SR309CI(CE)139	125
SR309CI(CE)179	165
SR309CI(CE)214	200
SR309CI(CE)240	226
SR309CI(CE)264	250
SR309CI(CE)290	276
SR309CI(CE)314	300
SR309CI(CE)340	326
SR309CI(CE)364	350
SR309CI(CE)488	474

#### Bright Zinc Plated Steel Type Part Numbers

Complete Set Assembled Chain Type	End Brackets Set
SR309	A309CU□□□KM□**

Complete Set Unassembled Chain Type	End Brackets Set
SR309	A309CU□□□K□**

\*Available on request in stainless steel  
\*\* 1=Pos.1; 2=Pos.2; 3=Pos.3  
See end brackets mounting variations page 31.

### Serie Protection

## SR309CI SR309CE

Nylon Protection Cable Chain with openable aluminium covers



For further information please consult Brevetti Stendalto's Technical Office

# Nylon Cable Chains Sliding Series

Series SR326SI-SR326SE	page 136
Series SR326B	page 138
Series SR326F	page 140
Series SR328SI-SR328SE	page 142
Series SR328B	page 144
Series SR328F	page 146
Series SR319SE	page 148
Series SR319B	page 150
Series SR478MI-SR478ME	page 152 <b>New</b>
Series SR478PI-SR478PE	page 154 <b>New</b>
Series M60PI-M60PE	page 156 <b>New</b>
Series M80PI-M80PE	page 158 <b>New</b>
Channel guide for long travel distance	
For Series SR326-SR328-M60	page 160
For Series SR475-SR478-SR319-M80	page 162

*Inner surface of chain  
completely smooth*

*Special End Brackets on  
moving end of chain*

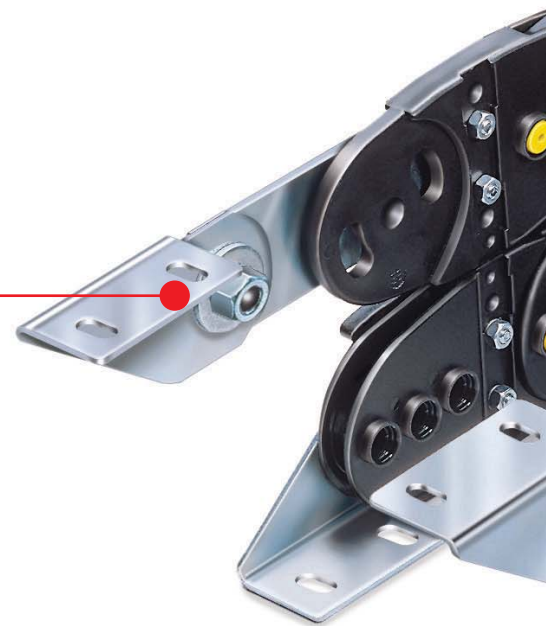

*Triple connecting Pivot Pin which offers high integrity in high performance applications*

*Nylon separator. Cables can be laid apart from each other*

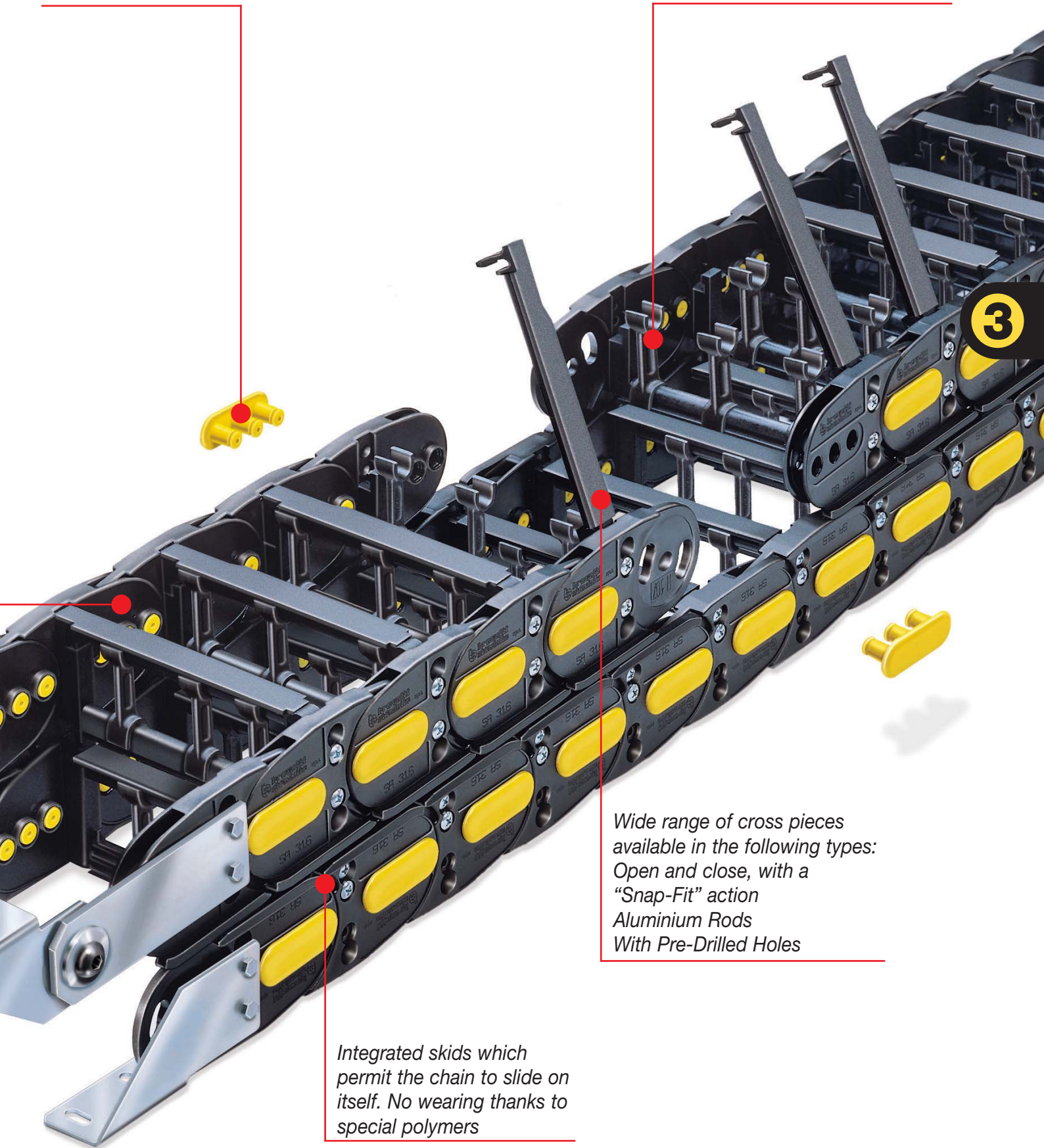

*Wide range of cross pieces available in the following types:  
Open and close, with a "Snap-Fit" action  
Aluminium Rods  
With Pre-Drilled Holes*

*Integrated skids which permit the chain to slide on itself. No wearing thanks to special polymers*

# Serie Sliding

## SR326SI/SR326SE Nylon Sliding Cable Chain with openable frames

### Inner height (D) 37 mm

Strong double share Sideband & Frame construction with large anti-friction triple-pin. The chain incorporates large sliding-skid surfaces to offer durability, even with high speed/loads. Frames openable from inner radius (..SI) and outer radius (..SE). As standard the chain comes with frames every second link, on request with frames every link. Modular separator systems are available.

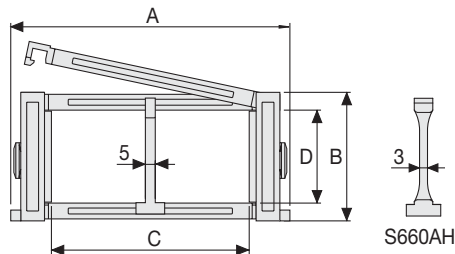

### Separator

- Unassembled Part.no S660A
- Assembled Part.no S660AMC

### Strong-hold separator

for C > 200 mm

- Unassembled Part.no S660AH
- Assembled Part.no S660AHMC

### Pin

Part.no PG307

### Technical characteristics

Speed	2 m/s
Acceleration	4 m/s <sup>2</sup>

For higher requirements please consult our technical dept.

A	B	C	D	R	Weight/m	Chain
mm	mm	mm	mm	mm	kg	Part Number
106	59	61	37	107-150-200-250-300	1,33	SR326SI(SE)061□□□*
117	59	72	37	107-150-200-250-300	1,33	SR326SI(SE)072□□□*
131	59	86	37	107-150-200-250-300	1,40	SR326SI(SE)086□□□*
137	59	92	37	107-150-200-250-300	1,41	SR326SI(SE)092□□□*
151	59	106	37	107-150-200-250-300	1,46	SR326SI(SE)106□□□*
156	59	111	37	107-150-200-250-300	1,46	SR326SI(SE)111□□□*
163	59	118	37	107-150-200-250-300	1,48	SR326SI(SE)118□□□*
173	59	128	37	107-150-200-250-300	1,49	SR326SI(SE)128□□□*
181	59	136	37	107-150-200-250-300	1,54	SR326SI(SE)136□□□*
192	59	147	37	107-150-200-250-300	1,57	SR326SI(SE)147□□□*
206	59	161	37	107-150-200-250-300	1,61	SR326SI(SE)161□□□*
231	59	186	37	107-150-200-250-300	1,68	SR326SI(SE)186□□□*
256	59	211	37	107-150-200-250-300	1,75	SR326SI(SE)211□□□*
267	59	222	37	107-150-200-250-300	1,79	SR326SI(SE)222□□□*
281	59	236	37	107-150-200-250-300	1,83	SR326SI(SE)236□□□*
308	59	263	37	107-150-200-250-300	1,91	SR326SI(SE)263□□□*
317	59	272	37	107-150-200-250-300	1,93	SR326SI(SE)272□□□*
368	59	323	37	107-150-200-250-300	2,06	SR326SI(SE)323□□□*
390	59	345	37	107-150-200-250-300	2,10	SR326SI(SE)345□□□*
418	59	373	37	107-150-200-250-300	2,21	SR326SI(SE)373□□□*

\*Complete the code by inserting the value of the radius (R): Ex. SR326SI(SE)118 □ □ □ □  
Chain equipped with nylon frame every pitch: complete the code by inserting the letter D.  
Ex. SR326SI(SE)118150 □

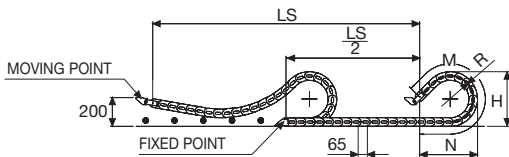

Length of chain (L)

Half travel distance ( $\frac{LS}{2}$ )

plus length of curve (M)

$$L = \frac{LS}{2} + M$$

R	H	N	M
mm	mm	mm	mm
107	273	290	650
150	359	440	1025
200	459	610	1460
250	559	785	1900
300	659	955	2340





### End Brackets

The end brackets set allows the two ends of the chain to be attached to the equipment. One set comprises two movable end brackets to install at the moving point and two standard steel end brackets to install at the fixed point.

**Bright Zinc Plated Steel Movable Type\* (moving point)**      **Bright Zinc Plated Steel Type\* (fixed point)**

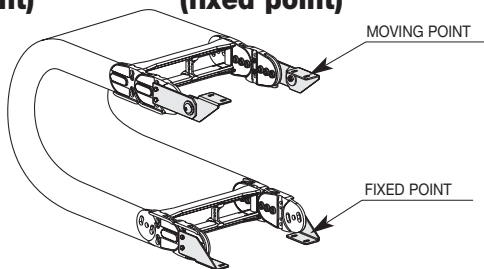
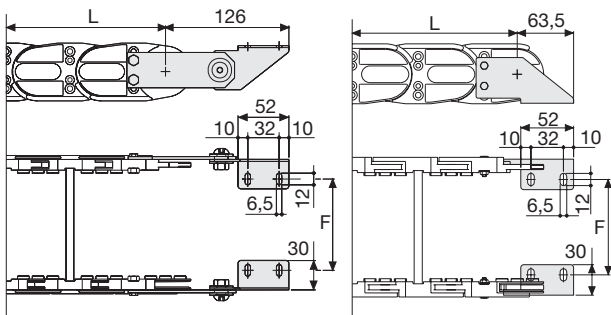

Fig. A  
Chain fixed outside the radius. (Fig A)



Chain Type	F mm
SR326SI(SE)061	58
SR326SI(SE)072	69
SR326SI(SE)086	83
SR326SI(SE)092	89
SR326SI(SE)106	103
SR326SI(SE)111	108
SR326SI(SE)118	115
SR326SI(SE)128	125
SR326SI(SE)136	133
SR326SI(SE)147	144
SR326SI(SE)161	158
SR326SI(SE)186	183
SR326SI(SE)211	208
SR326SI(SE)222	219
SR326SI(SE)236	233
SR326SI(SE)263	260
SR326SI(SE)272	269
SR326SI(SE)323	320
SR326SI(SE)345	342
SR326SI(SE)373	370

### Bright Zinc Plated Steel Type Part Numbers

Complete Set Assembled	
Chain	End Brackets
Type	Set
SR326SI(SE)...	A326KM

Complete Set Unassembled	
Chain	End Brackets
Type	Set
SR326SI(SE)...	A326K

\*Available on request in stainless steel

### Serie Sliding

## SR326SI SR326SE

Nylon Sliding Cable Chain  
with openable frames

3

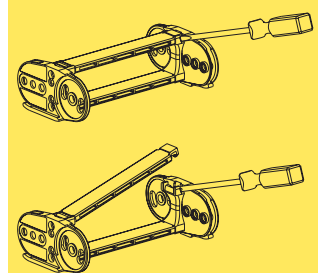

How to open the cover.

Special tool to remove the connecting pivots:  
Part Number PZ036.



For further information please consult Brevetti Stendalto's Technical Office

# Serie Sliding

# SR326B

## Nylon Sliding Cable Chain with un-screwable aluminium rods

### Inner height (D) 30 mm

Strong double share Sideband & Frame construction with large anti-friction triple-pin. The chain incorporates large sliding-skid surfaces to offer durability, even with high speed/loads. The Alu-rod frames are un-screwable from inner and outer radius. As standard the chain comes with frames every second link, on request with frames every link. Separator systems are available.

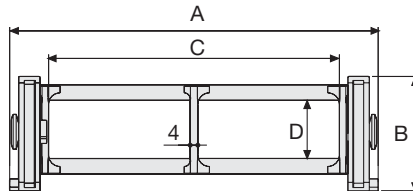

### Separator

- Unassembled	Part.no S2000F
- Assembled	Part.no S2000FMC

### Pin

Part.no PG307

### Technical characteristics

Speed	2 m/s
Acceleration	4 m/s <sup>2</sup>

For higher requirements please consult our technical dept.

A	B	C	D	R	Weight/m	Chain
mm	mm	mm	mm	mm	kg	Part Number
115	59	75	30	107-150-200-250-300	1,75	SR326B075□□□*
140	59	100	30	107-150-200-250-300	1,80	SR326B100□□□*
190	59	150	30	107-150-200-250-300	1,90	SR326B150□□□*
240	59	200	30	107-150-200-250-300	2,05	SR326B200□□□*
290	59	250	30	107-150-200-250-300	2,15	SR326B250□□□*
340	59	300	30	107-150-200-250-300	2,25	SR326B300□□□*
C+40	59	.....	30	107-150-200-250-300		SR326B □□□□□**

\*Complete the code by inserting the value of the radius (R): Ex. SR326B100 [1] [5] [0]

\*\*Complete the code by inserting the value of the quote C and the radius (R): Ex. SR326B [1] [2] [3] [1] [5] [0]

Chain equipped with aluminium rods every pitch: complete the code by inserting the letter D.

Ex. SR326B100150 [D]

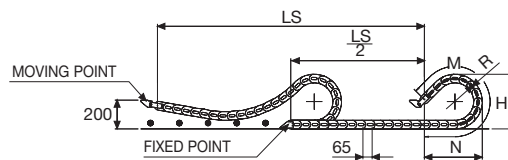

R	H	N	M
mm	mm	mm	mm
107	273	290	650
150	359	440	1025
200	459	610	1460
250	559	785	1900
300	659	950	2340

Length of chain (L)

Half travel distance ( $\frac{LS}{2}$ )

plus length of curve (M)

$$L = \frac{LS}{2} + M$$



### End Brackets

The end brackets set allows the two ends of the chain to be attached to the equipment. One set comprises two movable end brackets to install at the moving point and two standard steel end brackets to install at the fixed point.

**Bright Zinc Plated Steel Movable Type\* (moving point)**      **Bright Zinc Plated Steel Type\* (fixed point)**

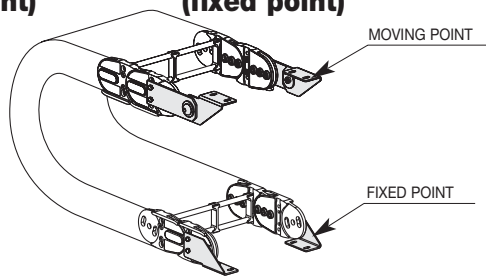
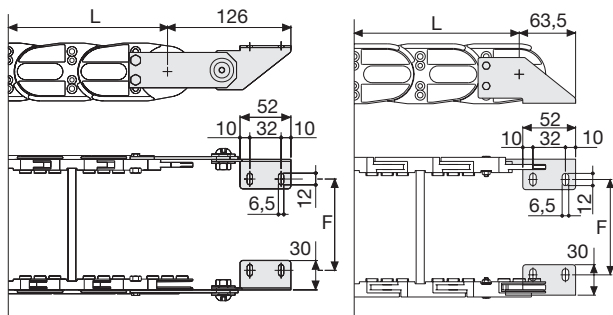

Fig. A  
Chain fixed outside the radius. (Fig A)



Chain Type	F mm
SR326B075	67
SR326B100	92
SR326B150	142
SR326B200	192
SR326B250	242
SR326B300	292
Special dimension F=A-48	

### Bright Zinc Plated Steel Type Part Numbers

Complete Set Assembled	
Chain	End Brackets
Type	Set
SR326B...	A326KM

Complete Set Unassembled	
Chain	End Brackets
Type	Set
SR326B...	A326K

\* Available on request in stainless steel

### Serie Sliding

## SR326B

Nylon Sliding Cable Chain with un-screwable aluminium rods

3

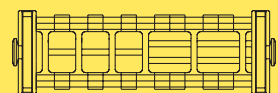

Supplementary movable separators.

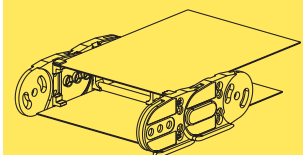

Steel laminar cover.

Special tool to remove the connecting pivots:  
Part Number PZ036.



For further information please consult Brevetti Stendalto's Technical Office

# Serie Sliding

## SR326F

### Nylon Sliding Cable Chain with un-screwable split cross pieces with holes

Strong double share Sideband & Frame construction with large anti-friction triple-pin. Un-screwable nylon split cross pieces with different hole combinations. The chain incorporates large sliding-skid surfaces to offer durability even, with high speed/loads. As standard the chain comes with frames every link.

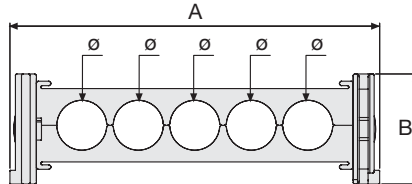

Pin
Part.no PG307

#### Technical characteristics

Speed	2 m/s
Acceleration	4 m/s <sup>2</sup>

For higher requirements please consult our technical dept.

A	B	N.	Ø	R	Weight/m	Chain
mm	mm	holes	mm	mm	kg	Part Number
89	59	2	22	107-150-200-250-300	1,95	SR326001□□□*
155	59	6	17	107-150-200-250-300	2,20	SR326002□□□*
193	59	6+2	17+20	107-150-200-250-300	2,45	SR326003□□□*
214	59	6	25	107-150-200-250-300	2,70	SR326004□□□*
113	59	3	23	107-150-200-250-300	2,10	SR326005□□□*

\*Complete the code by inserting the value of the radius (R): Ex. SR326001 [1] [5] [0]

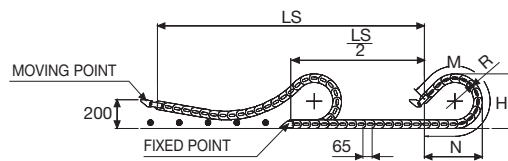

R	H	N	M
mm	mm	mm	mm
107	273	290	650
150	359	440	1025
200	459	610	1460
250	559	785	1900
300	659	955	2340

Length of chain (L)

Half travel distance ( $\frac{LS}{2}$ )  
plus length of curve (M)

$$L = \frac{LS}{2} + M$$



### End Brackets

The end brackets set allows the two ends of the chain to be attached to the equipment. One set comprises two movable end brackets to install at the moving point and two standard steel end brackets to install at the fixed point.

**Bright Zinc Plated Steel Movable Type\* (moving point)**      **Bright Zinc Plated Steel Type\* (fixed point)**

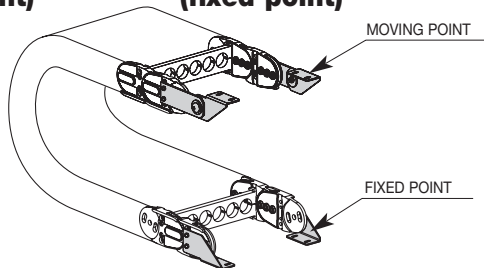
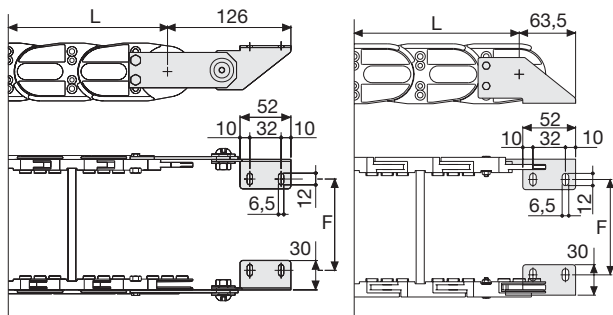

Fig. A  
Chain fixed outside the radius. (Fig A)



Chain Type	F mm
SR326001	41
SR326002	107
SR326003	145
SR326004	166
SR326005	65

### Bright Zinc Plated Steel Type Part Numbers

Complete Set Assembled	
Chain	End Brackets
Type	Set
SR32600...	A326KM

Complete Set Unassembled	
Chain	End Brackets
Type	Set
SR32600...	A326K

\*Available on request in stainless steel

### Serie Sliding

## SR326F

**Nylon Sliding Cable Chain with un-screwable nylon split cross pieces with holes**



3

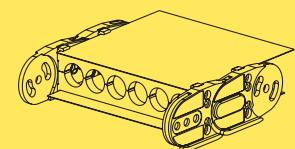

Steel laminar cover.

Special tool to remove the connecting pivots:  
Part Number PZ036.



For further information please consult Brevetti Stendalto's Technical Office

# Serie Sliding

# SR328SI/SR328SE

## Nylon Sliding Cable Chain with openable frames

### Inner height (D) 57 mm

Strong double share Sideband & Frame construction with large anti-friction triple-pin. The chain incorporates large sliding-skid surfaces to offer durability, even with high speed/loads. Frames openable from inner radius (..SI) and outer radius (..SE). As standard the chain comes with frames every second link, on request with frames every link. Modular separator systems are available.

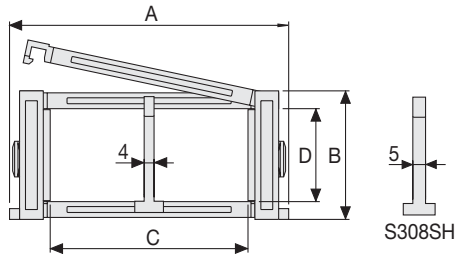

### Separator

- Unassembled Part.no S308C
- Assembled Part.no S308CMC

### Strong-hold separator

for C > 200 mm

- Unassembled Part.no S308SHF
- Assembled Part.no S308SHFMC

### Pin

Part.no PG328TP

### Technical characteristics

Speed	3,5 m/s
Acceleration	8 m/s <sup>2</sup>

For higher requirements please consult our technical dept.

A	B	C	D	R	Weight/m	Chain
mm	mm	mm	mm	mm	kg	Part Number
119	79	61	57	150-180-200-230-280-400	2,70	SR328SI(SE)061□□□*
130	79	72	57	150-180-200-230-280-400	2,73	SR328SI(SE)072□□□*
144	79	86	57	150-180-200-230-280-400	2,76	SR328SI(SE)086□□□*
150	79	92	57	150-180-200-230-280-400	2,78	SR328SI(SE)092□□□*
164	79	106	57	150-180-200-230-280-400	2,82	SR328SI(SE)106□□□*
169	79	111	57	150-180-200-230-280-400	2,82	SR328SI(SE)111□□□*
176	79	118	57	150-180-200-230-280-400	2,82	SR328SI(SE)118□□□*
186	79	128	57	150-180-200-230-280-400	2,86	SR328SI(SE)128□□□*
194	79	136	57	150-180-200-230-280-400	2,89	SR328SI(SE)136□□□*
205	79	147	57	150-180-200-230-280-400	2,89	SR328SI(SE)147□□□*
219	79	161	57	150-180-200-230-280-400	2,94	SR328SI(SE)161□□□*
244	79	186	57	150-180-200-230-280-400	3,01	SR328SI(SE)186□□□*
269	79	211	57	150-180-200-230-280-400	3,06	SR328SI(SE)211□□□*
280	79	222	57	150-180-200-230-280-400	3,08	SR328SI(SE)222□□□*
294	79	236	57	150-180-200-230-280-400	3,14	SR328SI(SE)236□□□*
321	79	263	57	150-180-200-230-280-400	3,20	SR328SI(SE)263□□□*
330	79	272	57	150-180-200-230-280-400	3,20	SR328SI(SE)272□□□*
381	79	323	57	150-180-200-230-280-400	3,31	SR328SI(SE)323□□□*
403	79	345	57	150-180-200-230-280-400	3,36	SR328SI(SE)345□□□*
431	79	373	57	150-180-200-230-280-400	3,49	SR328SI(SE)373□□□*

\*Complete the code by inserting the value of the radius (R): Ex. SR328SI(SE)118 □ □ □ □  
 Chain equipped with nylon frame every pitch: complete the code by inserting the letter D.  
 Ex. SR328SI(SE)118150 □

3

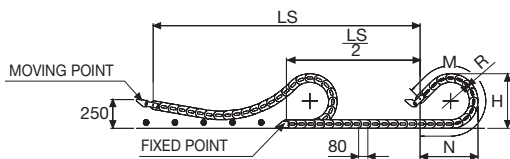

Length of chain (L)  
 Half travel distance ( $\frac{LS}{2}$ )  
 plus length of curve (M)

$$L = \frac{LS}{2} + M$$

R	H	N	M
mm	mm	mm	mm
150	375	425	955
180	435	530	1220
200	475	600	1395
230	535	700	1655
280	635	875	2095
400	875	1285	3145

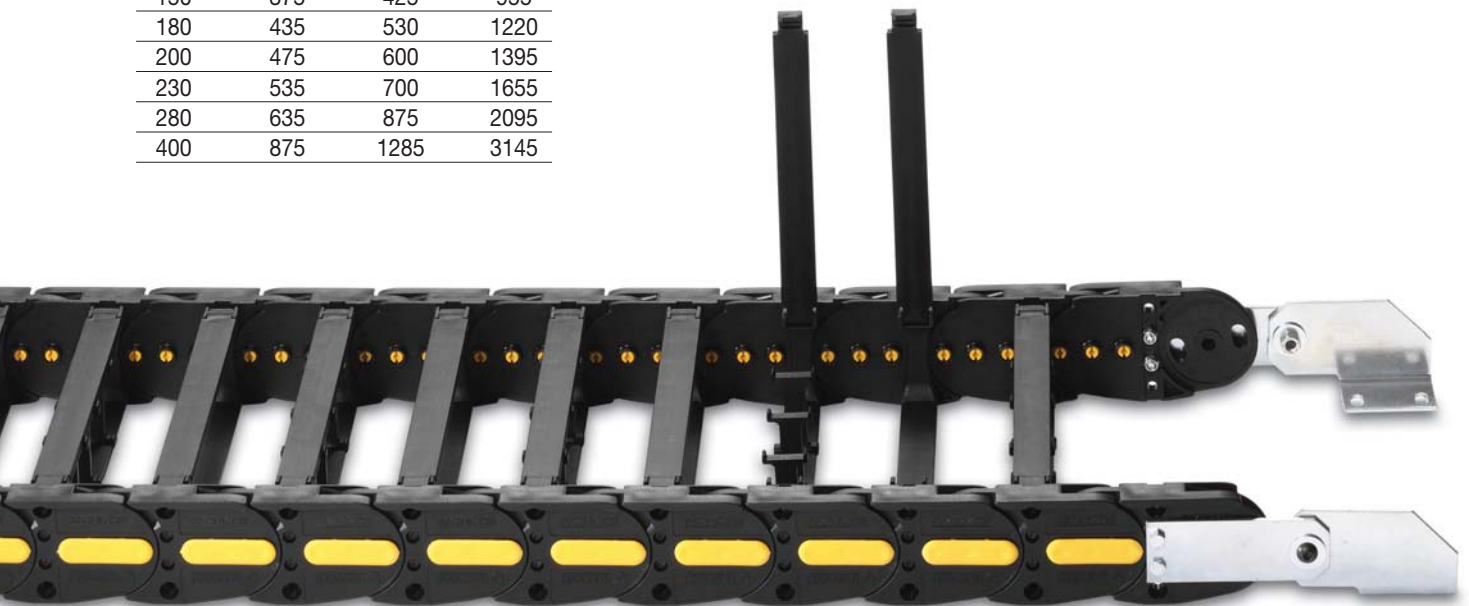

Version with frames mounted on every pitch.

### End Brackets

The end brackets set allows the two ends of the chain to be attached to the equipment. One set comprises two movable end brackets to install at the moving point and two standard steel end brackets to install at the fixed point.

**Bright Zinc Plated Steel Movable Type\* (moving point)**      **Bright Zinc Plated Steel Type\* (fixed point)**

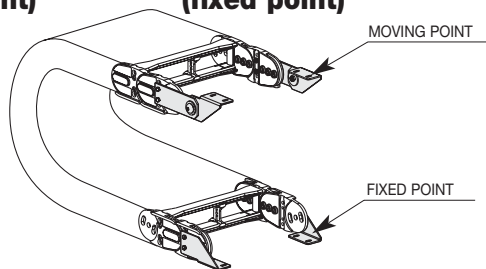
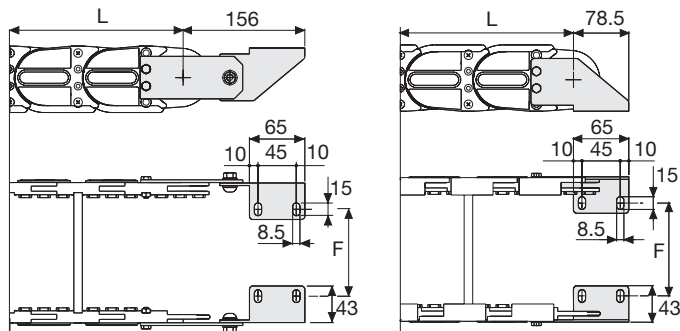

Fig. A  
Chain fixed outside the radius. (Fig A)



Chain Type	F mm
SR328SI(SE)061	44
SR328SI(SE)072	55
SR328SI(SE)086	69
SR328SI(SE)092	75
SR328SI(SE)106	89
SR328SI(SE)111	94
SR328SI(SE)118	101
SR328SI(SE)128	111
SR328SI(SE)136	119
SR328SI(SE)147	130
SR328SI(SE)161	144
SR328SI(SE)186	169
SR328SI(SE)211	194
SR328SI(SE)222	205
SR328SI(SE)236	219
SR328SI(SE)263	246
SR328SI(SE)272	255
SR328SI(SE)323	306
SR328SI(SE)345	328
SR328SI(SE)373	356

### Bright Zinc Plated Steel Type Part Numbers

Complete Set Assembled	
Chain	End Brackets
Type	Set
SR328SI(SE)...	A328KM

Complete Set Unassembled	
Chain	End Brackets
Type	Set
SR328SI(SE)...	A328K

\*Available on request in stainless steel

### Serie Sliding

## SR328SI SR328SE

Nylon Sliding Cable Chain  
with openable frames

3

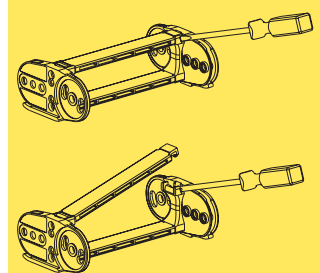

How to open the cover.

Special tool to remove the connecting pivots:  
Part Number PZ038.



For further information please consult Brevetti Stendalto's Technical Office

# Serie Sliding

## SR328B

### Nylon Sliding Cable Chain with un-screwable aluminium rods

#### Inner height (D) 48 mm

Strong double share Sideband & Frame construction with large anti-friction triple-pin. The chain incorporates large sliding-skid surfaces to offer durability, even with high speed/loads. The Alu-rod frames are un-screwable from inner and outer radius. As standard the chain comes with frames every second link, on request with frames every link. Separator systems are available.

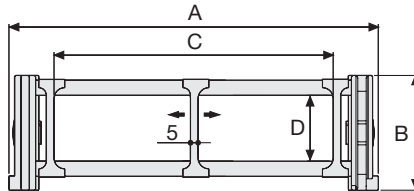

#### Separator

- Unassembled	Part.no S3000F
- Assembled	Part.no S3000FMC

#### Pin

Part.no PG328TP

#### Technical characteristics

Speed	3,5 m/s
Acceleration	8 m/s <sup>2</sup>

For higher requirements please consult our technical dept.

A	B	C	D	R	Weight/m	Chain
mm	mm	mm	mm	mm	kg	Part Number
162	79	100	48	150-180-200-230-280-400	2,50	SR328B100□□□*
212	79	150	48	150-180-200-230-280-400	2,60	SR328B150□□□*
262	79	200	48	150-180-200-230-280-400	2,75	SR328B200□□□*
312	79	250	48	150-180-200-230-280-400	2,90	SR328B250□□□*
362	79	300	48	150-180-200-230-280-400	3,00	SR328B300□□□*
C+62	79	.....	48	150-180-200-230-280-400		SR328B □□□□□**

\*Complete the code by inserting the value of the radius (R): Ex. SR328B100 1 5 0

\*\*Complete the code by inserting the value of the quote C and the radius (R): Ex. SR328B 1 2 3 1 5 0  
Chain equipped with aluminium rods every pitch: complete the code by inserting the letter D.  
Ex. SR328B100150 D

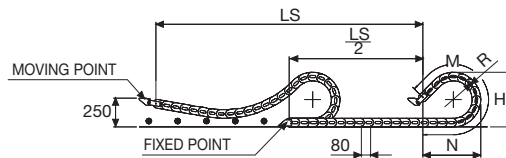

R	H	N	M
mm	mm	mm	mm
150	375	425	955
180	435	530	1220
200	475	600	1395
230	535	700	1655
280	635	875	2095
400	875	1285	3145

Length of chain (L)

Half travel distance ( $\frac{LS}{2}$ )

plus length of curve (M)

$$L = \frac{LS}{2} + M$$





### End Brackets

The end brackets set allows the two ends of the chain to be attached to the equipment. One set comprises two movable end brackets to install at the moving point and two standard steel end brackets to install at the fixed point.

**Bright Zinc Plated Steel Movable Type\* (moving point)**      **Bright Zinc Plated Steel Type\* (fixed point)**

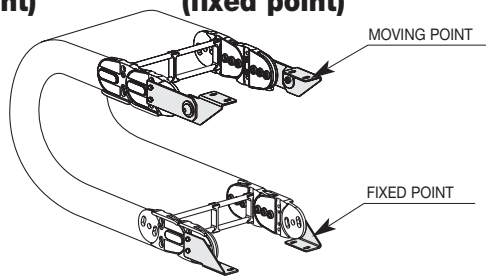
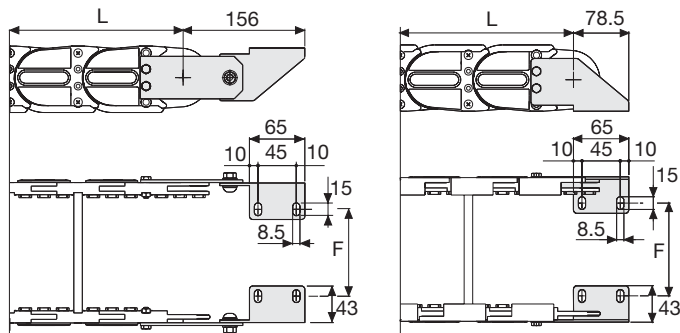

Fig. A  
Chain fixed outside the radius. (Fig A)



Chain Type	F mm
SR328B100	87
SR328B150	137
SR328B200	187
SR328B250	237
SR328B300	287
Special dimension F=A-75	

### Bright Zinc Plated Steel Type Part Numbers

Complete Set Assembled	
Chain	End Brackets
Type	Set
SR328B...	A328KM

Complete Set Unassembled	
Chain	End Brackets
Type	Set
SR328B...	A328K

\*Available on request in stainless steel

### Serie Sliding

## SR328B

Nylon Sliding Cable Chain with un-screwable aluminium rods

3

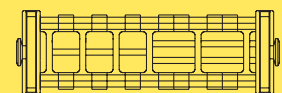

Supplementary movable separators.

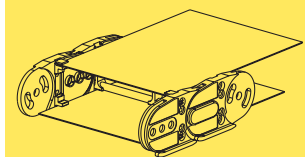

Steel laminar cover.

Special tool to remove the connecting pivots:  
Part Number PZ038.



For further information please consult Brevetti Stendalto's Technical Office

# Serie Sliding

# SR328F

## Nylon Cable Chain

### with un-screwable split cross pieces with holes

Strong double share Sideband & Frame construction with large anti-friction triple-pin. Un-screwable nylon split cross pieces with different hole combinations. The chain incorporates large sliding-skid surfaces to offer durability even, with high speed/loads. As standard the chain comes with frames every link.

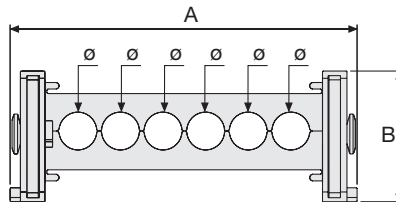

Pin
Part.no PG328TP

### Technical characteristics

Speed	3,5 m/s
Acceleration	8 m/s <sup>2</sup>

For higher requirements please consult our technical dept.

A	B	N.	Ø	R	Weight/m	Chain
mm	mm	holes	mm	mm	kg	Part Number
139	79	2	34	150-180-200-230-280-400	2,50	SR328001□□□*
227	79	6	25	150-180-200-230-280-400	2,85	SR328002□□□*
254	79	5	34	150-180-200-230-280-400	3,00	SR328003□□□*
292	79	6	34	150-180-200-230-280-400	3,10	SR328004□□□*
139	79	2+1	28-23	150-180-200-230-280-400	2,50	SR328005□□□*

\*Complete the code by inserting the value of the radius (R): Ex. SR328001 1 5 0

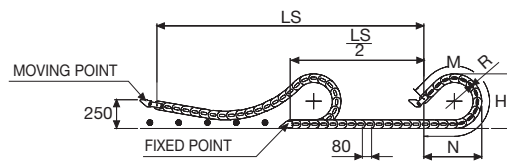

R	H	N	M
mm	mm	mm	mm
150	375	425	955
180	435	530	1220
200	475	600	1395
230	535	700	1655
280	635	875	2095
400	875	1285	3145

Length of chain (L)

Half travel distance ( $\frac{LS}{2}$ )  
plus length of curve (M)

$$L = \frac{LS}{2} + M$$



### End Brackets

The end brackets set allows the two ends of the chain to be attached to the equipment. One set comprises two movable end brackets to install at the moving point and two standard steel end brackets to install at the fixed point.

**Bright Zinc Plated Steel Movable Type\* (moving point)**      **Bright Zinc Plated Steel Type\* (fixed point)**

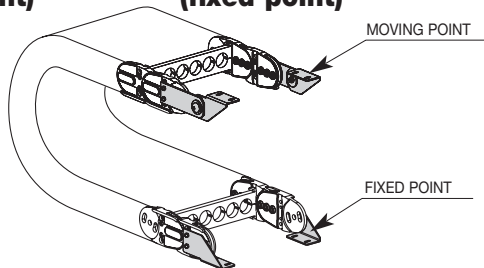
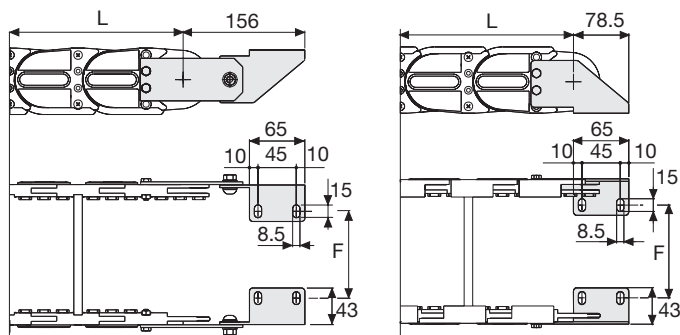

Fig. A  
Chain fixed outside the radius. (Fig A)



Chain Type	F mm
SR328001	64
SR328002	152
SR328003	179
SR328004	217
SR328005	64

### Bright Zinc Plated Steel Type Part Numbers

Complete Set Assembled	
Chain	End Brackets
Type	Set
SR32800...	A328KM

Complete Set Unassembled	
Chain	End Brackets
Type	Set
SR32800...	A328K

\*Available on request in stainless steel

### Serie Sliding

## SR328F

**Nylon Sliding Cable Chain with un-screwable nylon split cross pieces with holes**



3

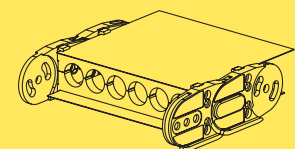

Steel laminar cover.

Special tool to remove the connecting pivots:  
Part Number PZ038.



For further information please consult Brevetti Stendalto's Technical Office

# Serie Sliding

## SR319SE Nylon Sliding Cable Chain with openable frames

### Inner height (D) 75,5 mm

Strong double share Sideband & Frame construction with large anti-friction triple-pin. The chain incorporates large sliding-skid surfaces to offer durability, even with high speed/loads. Frames openable from outer radius). As standard the chain comes with frames every second link, on request with frames every link. Modular separator systems are available

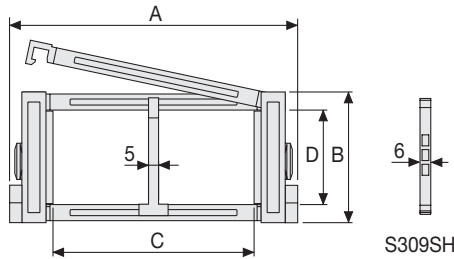

### Separator

- Unassembled Part.no S309S
- Assembled Part.no S309SMC

### Strong-hold separator

for C > 250 mm

- Unassembled Part.no S309SH
- Assembled Part.no S309SHMC

### Pin

Part.no PG319

### Technical characteristics

Speed	4 m/s
Acceleration	13 m/s <sup>2</sup>

For higher requirements please consult our technical dept.

A	B	C	D	R	Weight/m	Chain
mm	mm	mm	mm	mm	kg	Part Number
128	107	64	75,5	200-250-300-350-400-500	4,47	SR319SE064□□□*
148	107	84	75,5	200-250-300-350-400-500	4,53	SR319SE084□□□*
173	107	109	75,5	200-250-300-350-400-500	4,61	SR319SE109□□□*
180	107	116	75,5	200-250-300-350-400-500	4,64	SR319SE116□□□*
203	107	139	75,5	200-250-300-350-400-500	4,71	SR319SE139□□□*
243	107	179	75,5	200-250-300-350-400-500	4,84	SR319SE179□□□*
278	107	214	75,5	200-250-300-350-400-500	4,95	SR319SE214□□□*
304	107	240	75,5	200-250-300-350-400-500	5,04	SR319SE240□□□*
328	107	264	75,5	200-250-300-350-400-500	5,11	SR319SE264□□□*
354	107	290	75,5	200-250-300-350-400-500	5,19	SR319SE290□□□*
378	107	314	75,5	200-250-300-350-400-500	5,27	SR319SE314□□□*
404	107	340	75,5	200-250-300-350-400-500	5,34	SR319SE340□□□*
428	107	364	75,5	200-250-300-350-400-500	5,43	SR319SE364□□□*
552	107	488	75,5	200-250-300-350-400-500	5,85	SR319SE488□□□*

\*Complete the code by inserting the value of the radius (R): Ex. SR319SE116 □ □ □ □  
Chain equipped with nylon frame every pitch: complete the code by inserting the letter D.  
Ex. SR319SE116250 □

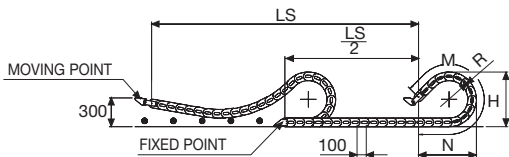

Length of chain (L)

Half travel distance ( $\frac{LS}{2}$ )

plus length of curve (M)

$$L = \frac{LS}{2} + M$$

R	H	N	M
mm	mm	mm	mm
200	507	595	1345
250	607	765	1780
300	707	940	2220
350	807	1110	2655
400	907	1280	3095
500	1107	1625	3970



### End Brackets

The end brackets set allows the two ends of the chain to be attached to the equipment. One set comprises two movable end brackets to install at the moving point and two standard steel end brackets to install at the fixed point.

**Bright Zinc Plated Steel Movable Type\* (moving point)**      **Bright Zinc Plated Steel Type\* (fixed point)**

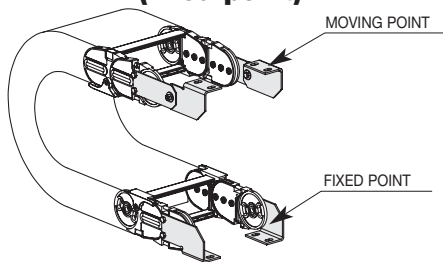
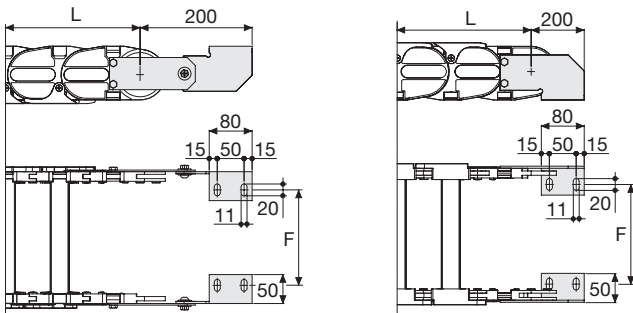

Fig. A  
Chain fixed outside the radius. (Fig A)



Chain Type	F mm
SR319SE064	40
SR319SE084	60
SR319SE109	85
SR319SE116	92
SR319SE139	115
SR319SE179	155
SR319SE214	190
SR319SE240	216
SR319SE264	240
SR319SE290	266
SR319SE314	290
SR319SE340	316
SR319SE364	340
SR319SE488	464

### Bright Zinc Plated Steel Type Part Numbers

Complete Set Assembled	
Chain Type	End Brackets Set
SR319SE...	A319KM

Complete Set Unassembled	
Chain Type	End Brackets Set
SR319SE...	A319K

\*Available on request in stainless steel

### Serie Sliding

## SR319SE

Nylon Sliding Cable Chain with openable frames

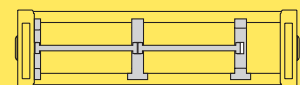

Separation System  
To choose the separators see page. 176

3

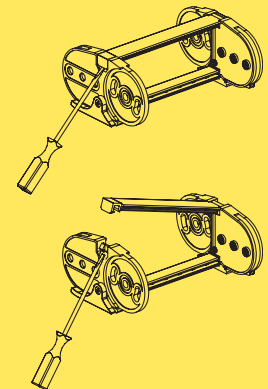

How to open the cover.

For further information please consult Brevetti Stendalto's Technical Office

# Serie Sliding

## SR319B

### Nylon Sliding Cable Chain with un-screwable aluminium rods

#### Inner height (D) 70 mm

Strong double share Sideband & Frame construction with large anti-friction triple-pin. The chain incorporates large sliding-skid surfaces to offer durability, even with high speed/loads. The Alu-rod frames are un-screwable from inner and outer radius. As standard the chain comes with frames every second link, on request with frames every link. Separator systems are available.

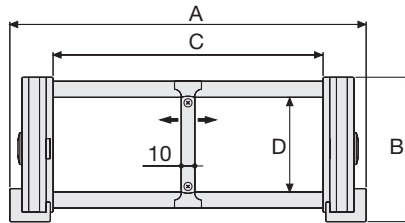

#### Separator

- Unassembled	Part.no S309C
- Assembled	Part.no S309CMC

#### Pin

Part.no PG319

#### Technical characteristics

Speed	4 m/s
Acceleration	13 m/s <sup>2</sup>

For higher requirements please consult our technical dept.

A	B	C	D	R	Weight/m	Chain
mm	mm	mm	mm	mm	kg	Part Number
164	107	100	70	200-250-300-350-400-500	4,25	SR319PSB100 □*
214	107	150	70	200-250-300-350-400-500	4,45	SR319PSB150 □*
264	107	200	70	200-250-300-350-400-500	4,60	SR319PSB200 □*
314	107	250	70	200-250-300-350-400-500	4,75	SR319PSB250 □*
364	107	300	70	200-250-300-350-400-500	4,90	SR319PSB300 □*
464	107	400	70	200-250-300-350-400-500	5,25	SR319PSB400 □*
C+64	107	.....	70	200-250-300-350-400-500		SR319PSB □□□ □**

\*Complete the code by inserting the value of the radius (R): Ex. SR319PSB150 □

Where: 2=200; 3=250; 4=300; 5=350; 6=400; 7=500

\*\*Complete the code by inserting the value of the quote C and the radius (R): Ex. SR319PSB □ □ □ □ □

Chain equipped with aluminium rods every pitch: complete the code by inserting the letter D.

Ex. SR319PSB1502 □

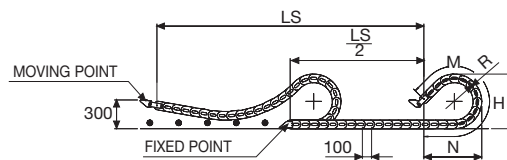

R	H	N	M
mm	mm	mm	mm
200	507	595	1345
250	607	765	1780
300	707	940	2220
350	807	1110	2655
400	907	1280	3095
500	1107	1625	3970

Length of chain (L)

Half travel distance ( $\frac{LS}{2}$ )

plus length of curve (M)

$$L = \frac{LS}{2} + M$$



### End Brackets

The end brackets set allows the two ends of the chain to be attached to the equipment. One set comprises two movable end brackets to install at the moving point and two standard steel end brackets to install at the fixed point.

**Bright Zinc Plated Steel Movable Type\* (moving point)**      **Bright Zinc Plated Steel Type\* (fixed point)**

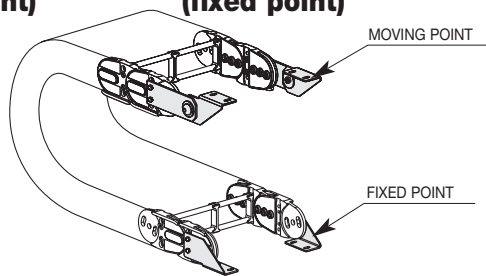
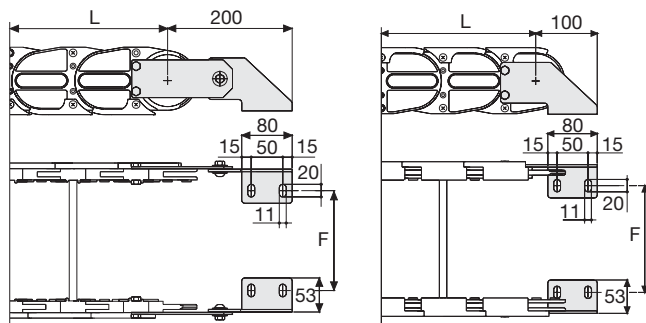

Fig. A  
Chain fixed outside the radius. (Fig A)



Chain Type	F mm
SR319PSB100	76
SR319PSB150	126
SR319PSB200	176
SR319PSB250	226
SR319PSB300	276
SR319PSB400	376
Special dimension F=A-88	

### Bright Zinc Plated Steel Type Part Numbers

Complete Set Assembled	
Chain	End Brackets
Type	Set
SR319PSB...	A319KM

Complete Set Unassembled	
Chain	End Brackets
Type	Set
SR319PSB...	A319K

\*Available on request in stainless steel

### Serie Sliding

## SR319B

Nylon Sliding Cable Chain with un-screwable aluminium rods

3

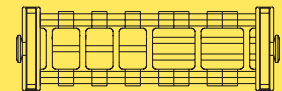

Supplementary movable separators.

### Version with aluminium draw plates



On request available with aluminium draw plates

Example Part Number:  
SR319T□□□\*□□□\*\*

\* Inner width (C)  
\*\* Bending radius (R)

For further information please consult Brevetti Stendalto's Technical Office

# SR478MI/SR478ME

## Nylon Cable Chain with openable frames

### Inner height (D) 75,5 mm

Sideband & Frame construction with large anti-friction single-pin. Covers are openable from inner radius (..MI) or from outer radius (..ME). As standard the chain comes with frames every second link, on request with frames every link. Modular separator systems are available

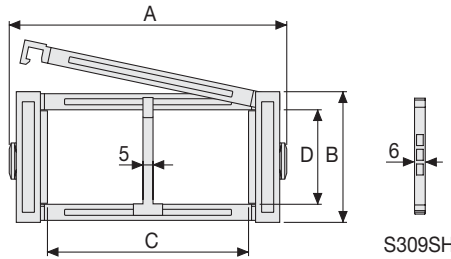

### Separator

- Unassembled Part.no S309S
- Assembled Part.no S309SMC

### Strong-hold separator

for C > 250 mm

- Unassembled Part.no S309SH
- Assembled Part.no S309SHMC

### Pin

Part.no PG475

### Technical characteristics

Speed	3 m/s
Acceleration	8 m/s <sup>2</sup>

For higher requirements please consult our technical dept.

3

A	B	C	D	R	Weight/m	Chain
mm	mm	mm	mm	mm	kg	Part number
112	106,5	74	75,5	150-180-200-250-300-350-400	3,70	SR478MI(ME)074□□□*
132	106,5	94	75,5	150-180-200-250-300-350-400	3,80	SR478MI(ME)094□□□*
157	106,5	119	75,5	150-180-200-250-300-350-400	3,85	SR478MI(ME)119□□□*
164	106,5	126	75,5	150-180-200-250-300-350-400	3,90	SR478MI(ME)126□□□*
187	106,5	149	75,5	150-180-200-250-300-350-400	3,95	SR478MI(ME)149□□□*
227	106,5	189	75,5	150-180-200-250-300-350-400	4,05	SR478MI(ME)189□□□*
262	106,5	224	75,5	150-180-200-250-300-350-400	4,15	SR478MI(ME)224□□□*
288	106,5	250	75,5	150-180-200-250-300-350-400	4,25	SR478MI(ME)250□□□*
312	106,5	274	75,5	150-180-200-250-300-350-400	4,30	SR478MI(ME)274□□□*
338	106,5	300	75,5	150-180-200-250-300-350-400	4,37	SR478MI(ME)300□□□*
362	106,5	324	75,5	150-180-200-250-300-350-400	4,45	SR478MI(ME)324□□□*
388	106,5	350	75,5	150-180-200-250-300-350-400	4,55	SR478MI(ME)350□□□*
412	106,5	374	75,5	150-180-200-250-300-350-400	4,60	SR478MI(ME)374□□□*
536	106,5	498	75,5	150-180-200-250-300-350-400	5,00	SR478MI(ME)498□□□*

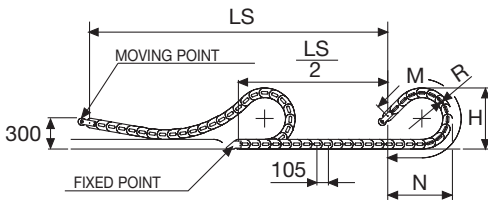

\*Complete the code by inserting the value of the radius (R): Ex. SR478MI(ME)119 □ □ □  
 Chain equipped with nylon frame every pitch: complete the code by inserting the letter D.  
 SR478MI(ME)119150 □

Length of chain (L)  
 Half travel distance ( $\frac{LS}{2}$ )  
 plus length of curve (M)

$$L = \frac{LS}{2} + M$$

R	H	N	M
mm	mm	mm	mm
150	406,5	365	805
180	466,5	420	960
200	506,5	495	1135
250	606,5	670	1570
300	706,5	845	2010
350	806,5	1015	2445
400	906,5	1190	2885



Version with frames mounted on every pitch.



### End Brackets

The end brackets set allows the two ends of the chain to be attached to the equipment. One set comprises two movable end brackets to install at the moving point and two standard steel end brackets to install at the fixed point.

**Bright Zinc Plated Steel Movable Type\* (fixed point)**      **Bright Zinc Plated Steel Type\* (moving point)**

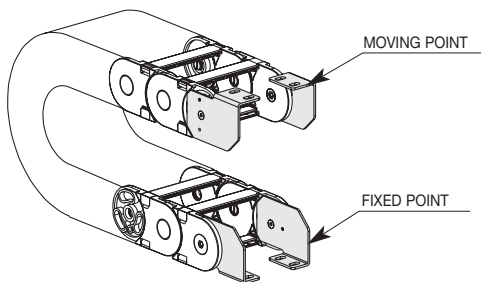
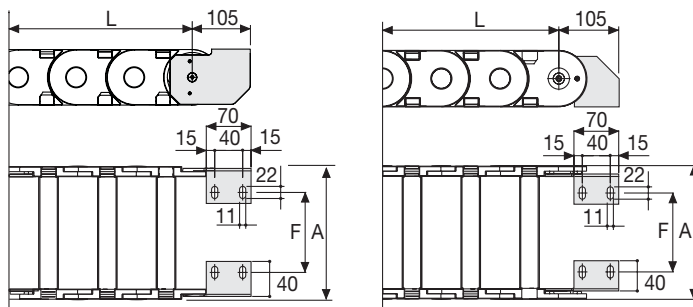

Fig. A  
Chain fixed outside the radius. (Fig A)



Chain Type	F mm
SR478MI(ME)074	35
SR478MI(ME)094	55
SR478MI(ME)119	80
SR478MI(ME)126	87
SR478MI(ME)149	110
SR478MI(ME)189	150
SR478MI(ME)224	185
SR478MI(ME)250	211
SR478MI(ME)274	235
SR478MI(ME)300	261
SR478MI(ME)324	285
SR478MI(ME)350	311
SR478MI(ME)374	335
SR478MI(ME)498	459

### Bright Zinc Plated Steel Type Part Numbers

Complete Set Assembled	
Chain	End Brackets
Type	Set
SR478MI/ME...	A478KM

Complete Set Unassembled	
Chain	End Brackets
Type	Set
SR478MI/ME...	A478K

Tiewrap Clamp	
Part Number	
Assembled	CFC478 □□□ *KM
Unassembled	CFC478 □□□ *K

\* Complete the code by inserting the value of the quote C.

### Serie Sliding

## SR478MI SR478ME

Nylon Cable Chain  
with openable frames

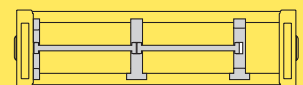

Separation System  
To choose the separators see  
page. 176

3

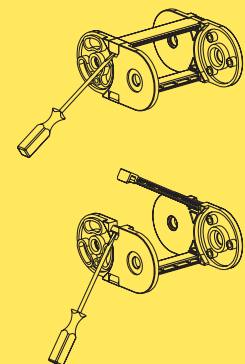

How to open the cover.

For further information please  
consult Brevetti Stendalto's  
Technical Office

# SR478PI/SR478PE

## Nylon Cable Chain with openable frames

### Inner height (D) 75,5 mm

Sideband & Frame construction with large anti-friction single-pin.  
Covers are openable from inner radius (478PI) or from outer radius (478PE).  
Vertical and horizontal modular separator system are available.

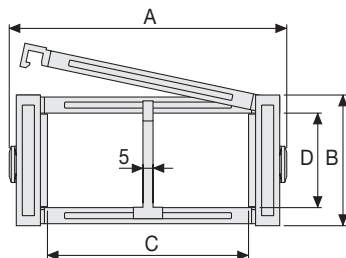

### Separator

- Unassembled	Part.no S309S
- Assembled	Part.no S309SMC

### Pin

Part.no PG475

### Technical characteristics

Speed	3 m/s
Acceleration	8 m/s <sup>2</sup>

For higher requirements please consult our technical dept.

3

A	B	C	D	R	Weight/m	Chain
mm	mm	mm	mm	mm	kg	Part number
112	106,5	74	75,5	180-200-250-300-350-400	4,60	SR478PI(PE)074□□□*
132	106,5	94	75,5	180-200-250-300-350-400	4,80	SR478PI(PE)094□□□*
157	106,5	119	75,5	180-200-250-300-350-400	5,10	SR478PI(PE)119□□□*
164	106,5	126	75,5	180-200-250-300-350-400	5,15	SR478PI(PE)126□□□*
187	106,5	149	75,5	180-200-250-300-350-400	5,40	SR478PI(PE)149□□□*
227	106,5	189	75,5	180-200-250-300-350-400	5,80	SR478PI(PE)189□□□*
262	106,5	224	75,5	180-200-250-300-350-400	6,20	SR478PI(PE)224□□□*
288	106,5	250	75,5	180-200-250-300-350-400	6,50	SR478PI(PE)250□□□*
312	106,5	274	75,5	180-200-250-300-350-400	6,75	SR478PI(PE)274□□□*
338	106,5	300	75,5	180-200-250-300-350-400	7,05	SR478PI(PE)300□□□*
362	106,5	324	75,5	180-200-250-300-350-400	7,30	SR478PI(PE)324□□□*
388	106,5	350	75,5	180-200-250-300-350-400	7,55	SR478PI(PE)350□□□*
412	106,5	374	75,5	180-200-250-300-350-400	7,85	SR478PI(PE)374□□□*
536	106,5	498	75,5	180-200-250-300-350-400	9,20	SR478PI(PE)498□□□*

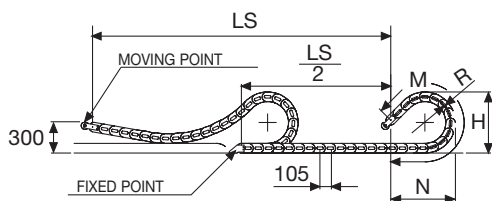

\*Complete the code by inserting the value of the radius (R): Ex. SR478PI(PE)119 □ □ □ □

Length of chain (L)

Half travel distance ( $\frac{LS}{2}$ )

plus length of curve (M)

$$L = \frac{LS}{2} + M$$

R	H	N	M
mm	mm	mm	mm
180	466,5	420	960
200	506,5	495	1135
250	606,5	670	1570
300	706,5	845	2010
350	806,5	1015	2445
400	906,5	1190	2885



## End Brackets

The end brackets set allows the two ends of the chain to be attached to the equipment. One set comprises two movable end brackets to install at the moving point and two standard steel end brackets to install at the fixed point.

**Bright Zinc Plated Steel Movable Type\* (fixed point)**      **Bright Zinc Plated Steel Type\* (moving point)**

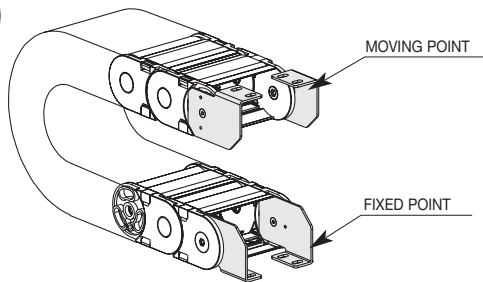
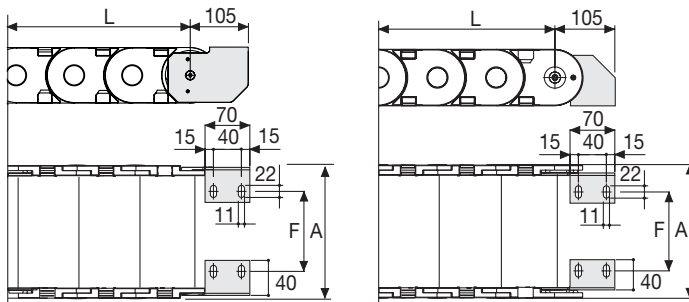

Fig. A  
Chain fixed outside the radius. (Fig A)



Chain Type	F mm
SR478PI(PE)074	35
SR478PI(PE)094	55
SR478PI(PE)119	80
SR478PI(PE)126	87
SR478PI(PE)149	110
SR478PI(PE)189	150
SR478PI(PE)224	185
SR478PI(PE)250	211
SR478PI(PE)274	235
SR478PI(PE)300	261
SR478PI(PE)324	285
SR478PI(PE)350	311
SR478PI(PE)374	335
SR478PI(PE)498	459

## Bright Zinc Plated Steel Type Part Numbers

Complete Set Assembled	
Chain	End Brackets
Type	Set
SR478PI/PE...	A478P□□□KM

Complete Set Unassembled	
Chain	End Brackets
Type	Set
SR478PI/PE...	A478P□□□K

Tiewrap Clamp	
Codice	
Assembled	CFC478□□□*KM
Unassembled	CFC478□□□*K

\* Complete the code by inserting the value of the quote C.

## Serie Sliding

**SR478PI**  
**SR478PE**  
Nylon Cable Chain  
with openable frames

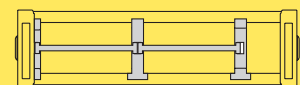

Separation System  
To choose the separators see  
page. 176

3

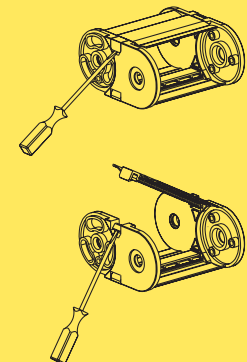

How to open the cover.

For further information please  
consult Brevetti Stendalto's  
Technical Office

## M60PI/M60PE Nylon Cable Chain with openable frames

### Inner height (D) 60,5 mm

Sideband & Frame construction with large anti-friction single-pin.

Frames openable from inner radius (..PI) and outer radius (..PE).

As standard the chain comes with frames every second link, on request with frames every link.

Vertical separators are available

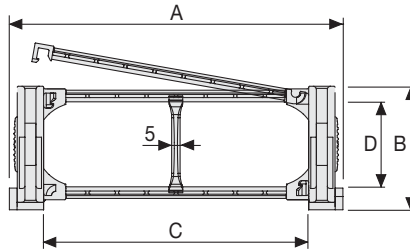

### Separator

- Unassembled Part.no S60

- Assembled Part.no S60MC

### Strong-hold separator

for C > 250 mm

- Unassembled Part.no S60H

- Assembled Part.no S60HMC

### Pin

Part.no PGE60-PNI60S

### Technical characteristics

Speed	5 m/s
Acceleration	13 m/s <sup>2</sup>

For higher requirements please consult our technical dept.

3

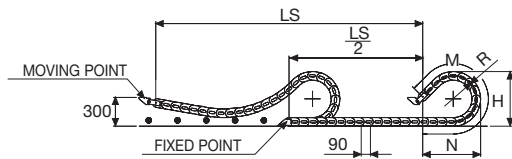

Length of chain (L)

Half travel distance ( $\frac{LS}{2}$ )

plus length of curve (M)

$$L = \frac{LS}{2} + M$$

R	H	N	M
mm	mm	mm	mm
150	390	450	1010
200	490	740	1660
250	590	1070	2400
300	690	1405	3140
400	890	2075	4620

A	B	C	D	R	Weight/m	Chain
mm	mm	mm	mm	mm	kg	Part number
165	90	115	60,5	150-200-250-300-400	4,87	M60PI(PE)115 □□□*
185	90	135	60,5	150-200-250-300-400	4,96	M60PI(PE)135 □□□*
210	90	160	60,5	150-200-250-300-400	5,02	M60PI(PE)160 □□□*
217	90	167	60,5	150-200-250-300-400	5,04	M60PI(PE)167 □□□*
240	90	190	60,5	150-200-250-300-400	5,11	M60PI(PE)190 □□□*
280	90	230	60,5	150-200-250-300-400	5,27	M60PI(PE)230 □□□*
315	90	265	60,5	150-200-250-300-400	5,41	M60PI(PE)265 □□□*
341	90	291	60,5	150-200-250-300-400	5,49	M60PI(PE)291 □□□*
365	90	315	60,5	150-200-250-300-400	5,57	M60PI(PE)315 □□□*
391	90	341	60,5	150-200-250-300-400	5,67	M60PI(PE)341 □□□*
415	90	365	60,5	150-200-250-300-400	5,76	M60PI(PE)365 □□□*
441	90	391	60,5	150-200-250-300-400	5,84	M60PI(PE)391 □□□*
465	90	415	60,5	150-200-250-300-400	5,93	M60PI(PE)415 □□□*
589	90	539	60,5	150-200-250-300-400	6,58	M60PI(PE)539 □□□*

\*Complete the code by inserting the value of the radius (R): Ex. M60PI(PE)115 □ □ □ □

Chain equipped with nylon frame every pitch: complete the code by inserting the letter D.

M60PI(PE)115250 □



### End Brackets

The end brackets set allows the two ends of the chain to be attached to the equipment. One set comprises two movable end brackets to install at the moving point and two standard steel end brackets to install at the fixed point.

#### Bright Zinc Plated Steel Movable Type\* (fixed point)

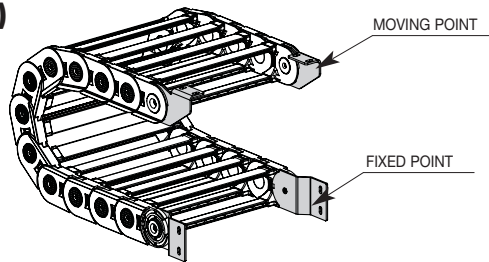
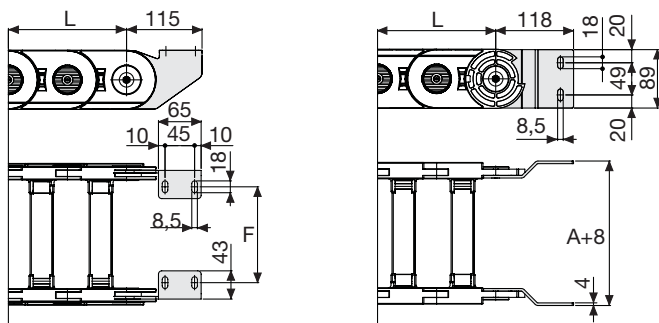

Fig. A  
Chain fixed outside the radius. (Fig A)



Chain Type	F mm
M60PI(PE)115	95
M60PI(PE)135	115
M60PI(PE)160	140
M60PI(PE)167	147
M60PI(PE)190	170
M60PI(PE)230	210
M60PI(PE)265	245
M60PI(PE)291	271
M60PI(PE)315	295
M60PI(PE)341	321
M60PI(PE)365	345
M60PI(PE)391	371
M60PI(PE)415	395
M60PI(PE)539	519

### Bright Zinc Plated Steel Type Part Numbers

Complete Set Assembled	
Chain	End Brackets
Type	Set
M60PI/PE...	A60PKM

Complete Set Unassembled	
Chain	End Brackets
Type	Set
M60PI/PE...	A60PK

\*Available on request in stainless steel

### Serie Sliding

## M60PI

## M60PE

Nylon Cable Chain with openable frames

3

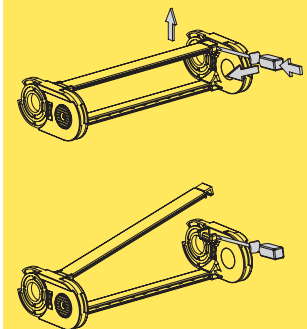

How to open the cover.

For further information please consult Brevetti Stendalto's Technical Office

## M80PI/M80PE Nylon Cable Chain with openable frames

### Inner height (D) 80,5 mm

Sideband & Frame construction with large anti-friction single-pin.

Frames openable from inner radius (..PI) and outer radius (..PE).

As standard the chain comes with frames every second link, on request with frames every link.

Vertical separators are available

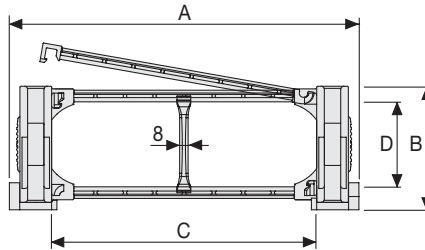

### Separator

- Unassembled Part.no S80
- Assembled Part.no S80MC

### Strong-hold separator

for C > 250 mm

- Unassembled Part.no S80H
- Assembled Part.no S80HMC

### Pin

Part.no PGE80-PNI80

### Technical characteristics

Speed	5 m/s
Acceleration	13 m/s <sup>2</sup>

For higher requirements please consult our technical dept.

A	B	C	D	R	Weight/m	Chain
mm	mm	mm	mm	mm	kg	Part number
195	117	115	80,5	200-250-300-400-500-700	8,60	M80PI(PE)115 □□□*
215	117	135	80,5	200-250-300-400-500-700	8,67	M80PI(PE)135 □□□*
240	117	160	80,5	200-250-300-400-500-700	8,73	M80PI(PE)160 □□□*
247	117	167	80,5	200-250-300-400-500-700	8,75	M80PI(PE)167 □□□*
270	117	190	80,5	200-250-300-400-500-700	8,80	M80PI(PE)190 □□□*
310	117	230	80,5	200-250-300-400-500-700	8,93	M80PI(PE)230 □□□*
345	117	265	80,5	200-250-300-400-500-700	9,05	M80PI(PE)265 □□□*
371	117	291	80,5	200-250-300-400-500-700	9,11	M80PI(PE)291 □□□*
395	117	315	80,5	200-250-300-400-500-700	9,17	M80PI(PE)315 □□□*
421	117	341	80,5	200-250-300-400-500-700	9,25	M80PI(PE)341 □□□*
445	117	365	80,5	200-250-300-400-500-700	9,33	M80PI(PE)365 □□□*
471	117	391	80,5	200-250-300-400-500-700	9,40	M80PI(PE)391 □□□*
495	117	415	80,5	200-250-300-400-500-700	9,47	M80PI(PE)415 □□□*
619	117	539	80,5	200-250-300-400-500-700	10,00	M80PI(PE)539 □□□*

\*Complete the code by inserting the value of the radius (R): Ex. M80PI(PE)115 □ □ □ □  
Chain equipped with nylon frame every pitch: complete the code by inserting the letter D.  
M80PI(PE)115250 □

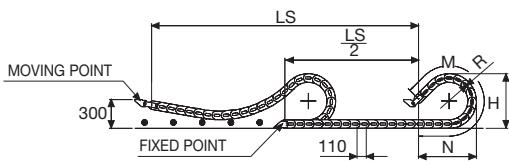

Length of chain (L)

Half travel distance ( $\frac{LS}{2}$ )

plus length of curve (M)

$$L = \frac{LS}{2} + M$$

R	H	N	M
mm	mm	mm	mm
200	517	790	1730
250	617	1120	2480
300	717	1460	3220
400	917	2120	4700
500	1117	2780	6180
700	1517	4120	9150



### End Brackets

The end brackets set allows the two ends of the chain to be attached to the equipment. One set comprises two movable end brackets to install at the moving point and two standard steel end brackets to install at the fixed point.

### Bright Zinc Plated Steel Movable Type\* (fixed point)

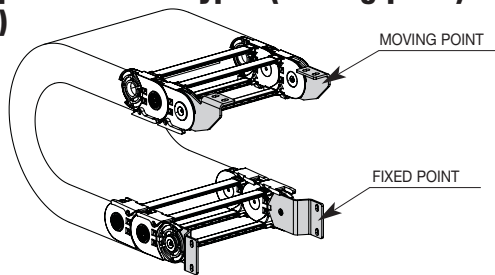
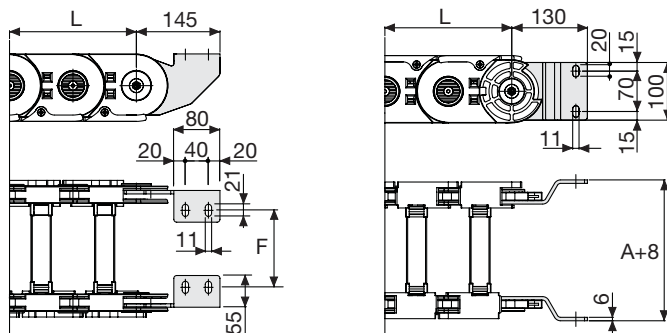

Fig. A  
Chain fixed outside the radius. (Fig A)



Chain Type	F mm
M80PI(PE)115	92
M80PI(PE)135	112
M80PI(PE)160	137
M80PI(PE)167	144
M80PI(PE)190	167
M80PI(PE)230	207
M80PI(PE)265	242
M80PI(PE)291	268
M80PI(PE)315	292
M80PI(PE)341	318
M80PI(PE)365	342
M80PI(PE)391	368
M80PI(PE)415	392
M80PI(PE)539	516

### Bright Zinc Plated Steel Type Part Numbers

Complete Set Assembled	
Chain	End Brackets
Type	Set
M80PI/PE...	A80PKM

Complete Set Unassembled	
Chain	End Brackets
Type	Set
M80PI/PE...	A80PK

\*Available on request in stainless steel

### Serie Sliding

## M80PI

## M80PE

Nylon Cable Chain with openable frames

3

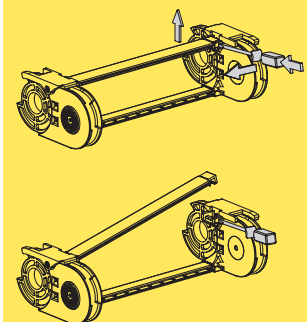

How to open the cover.

For further information please consult Brevetti Stendalto's Technical Office

# Serie Sliding

# Guide Channel

## SR445-SR660A-SR770A-SR326-SR328-M60

Special guide channel allows the use of the chain for long travel distance.  
Available in galvanised steel and, on request, in stainless steel.

### Single Chain Application

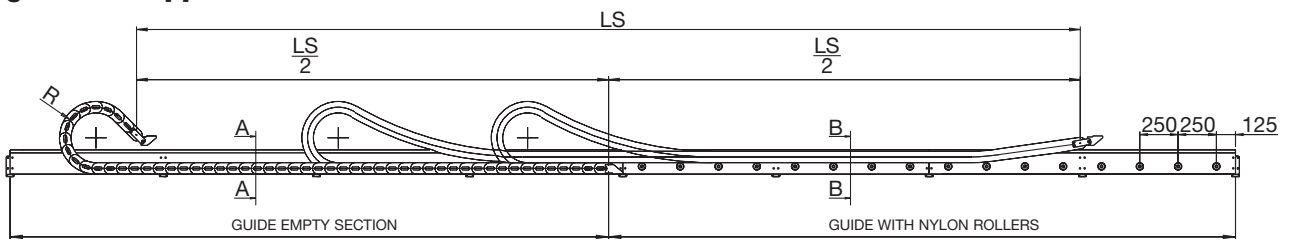

### Double Chain Application

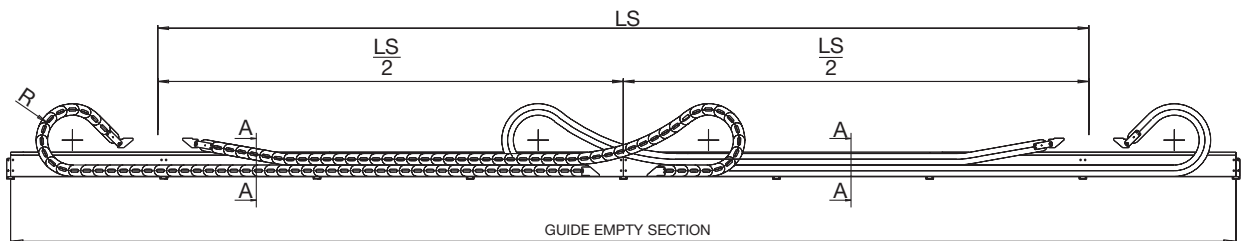

Channel guide is available in assembling kit composed by:  
side walls 2 m standard length  
joining and support plates  
fixing screws  
base  
sliding device (nylon wheel/steel or plastic plate)

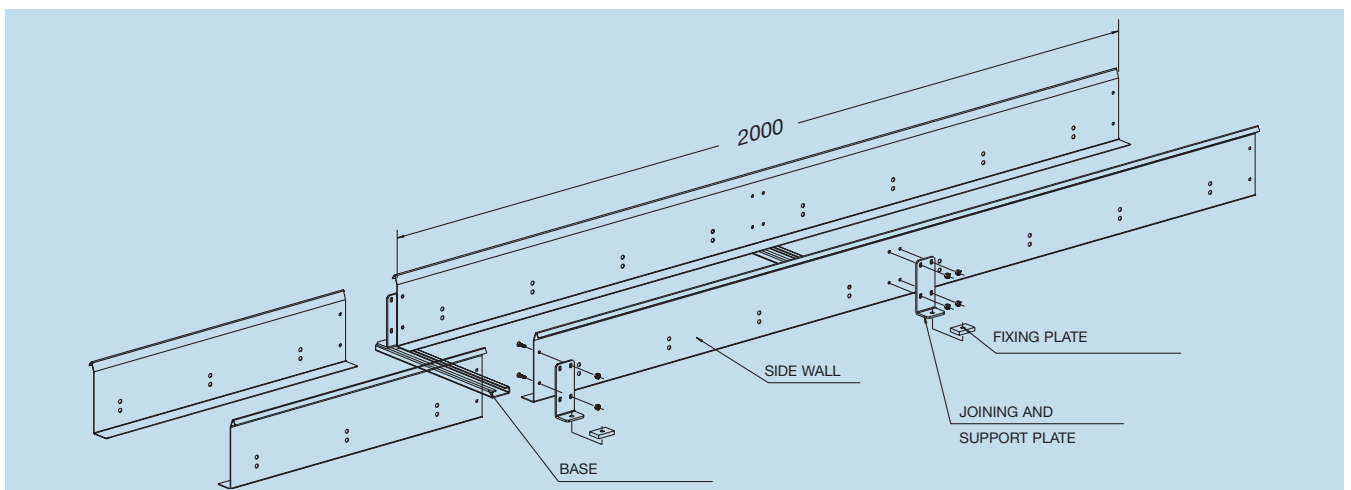



### Empty Guide Section

Section A-A

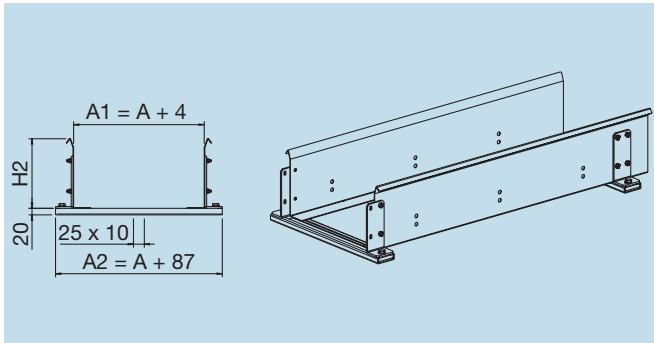

#### Part Number

**CS326...**

How to order

Chain part number **SR326B100150**

Guide channel part number **CS326B100**

### Serie Sliding

Chain	H2 mm	H1 mm
SR445	160	64
SR660	160	59
SR326	160	59
SR770A	160	79
SR328	160	79
M60	180	90

### Guide with Nylon Rollers

Section B-B

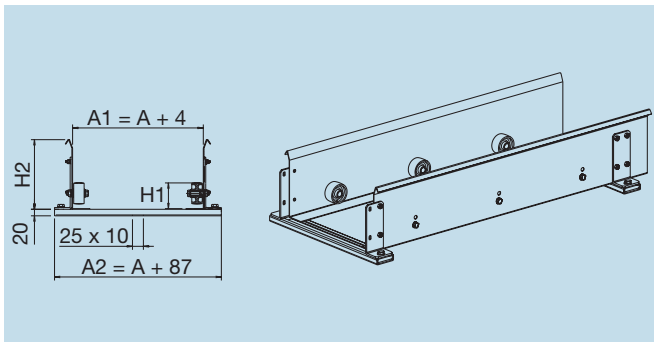

#### Part Number

**CR326...**

How to order

Chain part number **SR326B100150**

Guide channel part number **CR326B100**

### Guide with Steel Sliding Plate

Section B-B

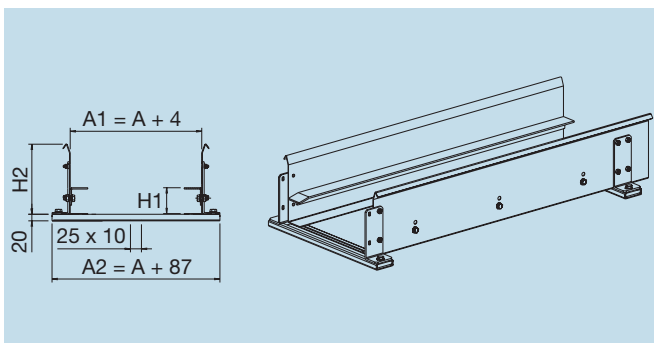

#### Part Number

**CA326...**

How to order

Chain part number **SR326B100150**

Guide channel part number **CA326B100**

### Guide with Plastic Sliding Plate

Section B-B

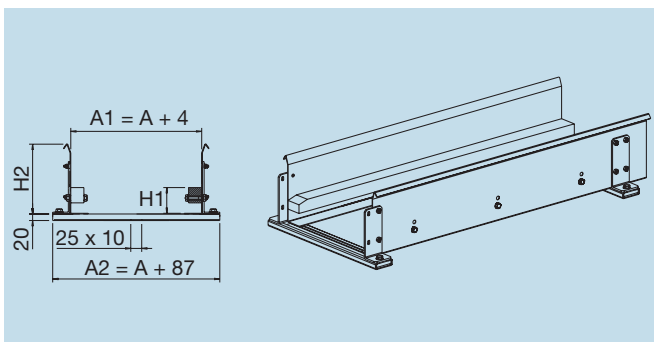

#### Part Number

**CP326...**

How to order

Chain part number **SR326B100150**

Guide channel part number **CP326B100**

For further information please consult Brevetti Stendalto's Technical Office

# Serie Sliding

## Guide Channel SR475-SR478-SR319-M80

Special guide channel allows the use of the chain for long travel distance  
Available in galvanised steel and, on request, in stainless steel.

### Single Chain Application

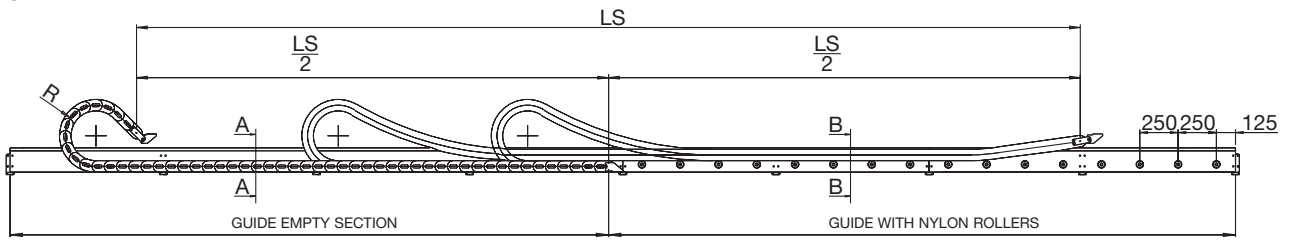

### Double Chain Application

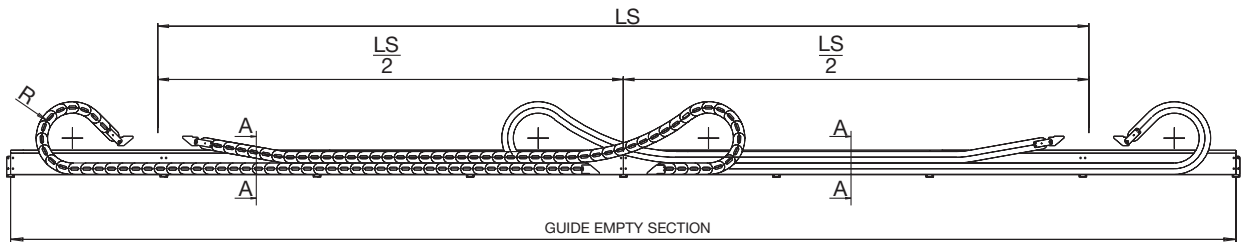

Channel guide is available in assembling kit composed by:  
side walls 2 m standard length  
joining and support plates  
fixing screws  
base  
sliding device (nylon wheel/steel or plastic plate)

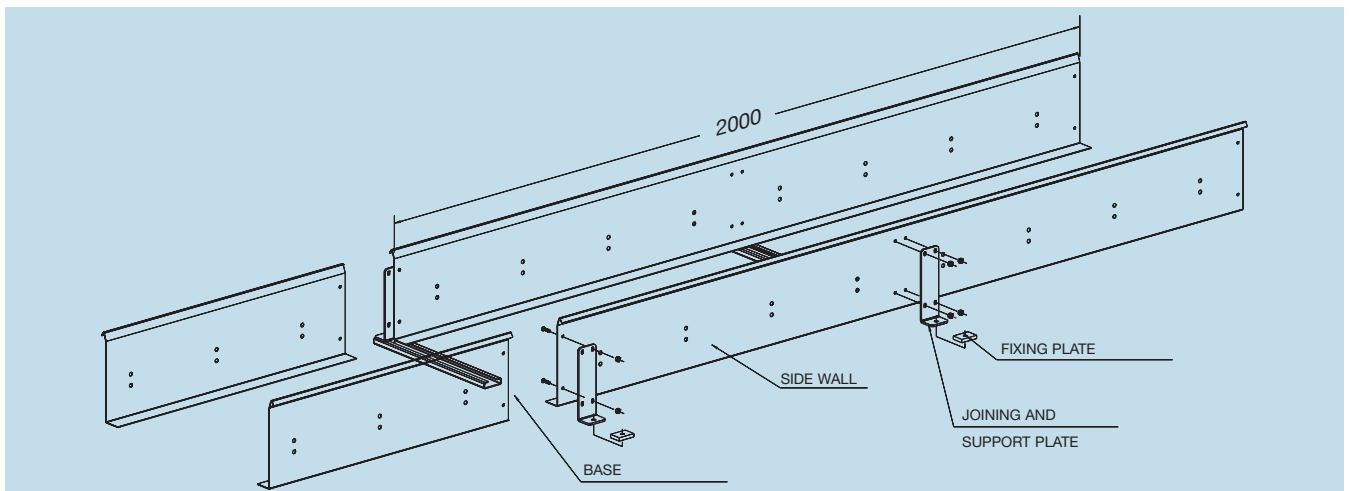

### Empty Guide Section

Section A-A

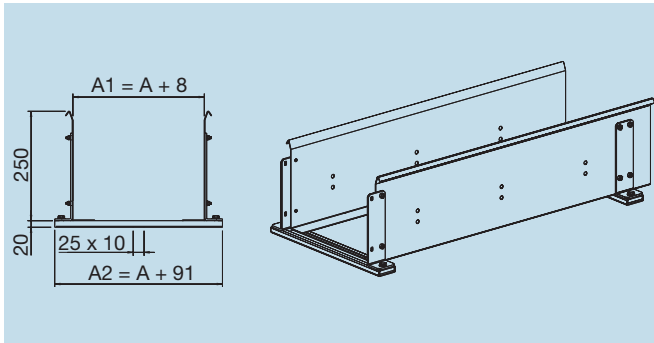

#### Part Number

**CS319...**

How to order

Chain part number **SR319PSB100200**

Guide channel part number **CS319B100**

### Serie Sliding

Chain	H1 mm
SR475	100
SR478	107
SR319	107
M80	117

### Guide with Nylon Rollers

Section B-B

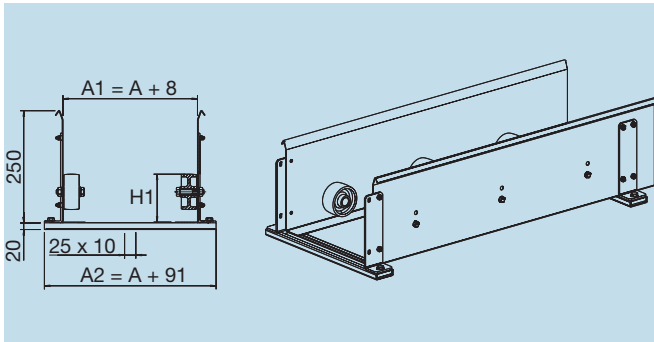

#### Part Number

**CR319...**

How to order

Chain part number **SR319PSB100200**

Guide channel part number **CR319B100**

### Guide with Steel Sliding Plate

Section B-B

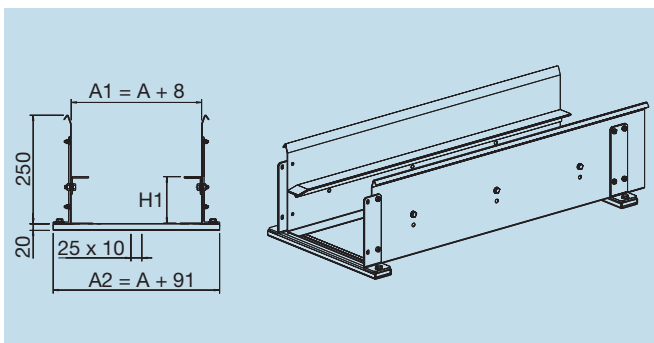

#### Part Number

**CA319...**

How to order

Chain part number **SR319PSB100200**

Guide channel part number **CA319B100**

### Guide with Plastic Sliding Plate

Section B-B

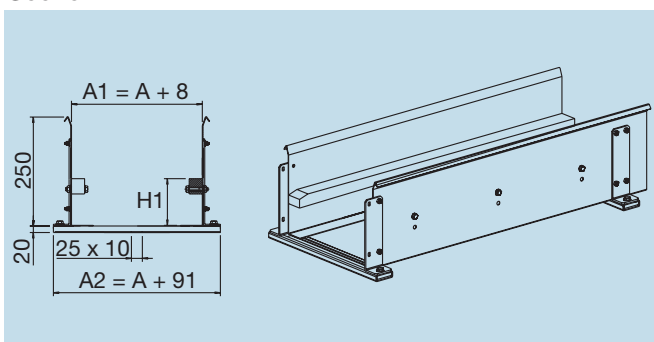

#### Part Number

**CP319...**

How to order

Chain part number **SR319PSB100200**

Guide channel part number **CP319B100**

For further information please consult Brevetti Stendalto's Technical Office



# Nylon Cable Chains Robot Series

Series SR495	page 166
Series SR500	page 168
Series SR510TN	page 170
Series SR515TN	page 170
Series SR545	page 172
Series SR599	page 174

*Quickly removable  
covers for easy  
installation of the  
cables/hoses*

---

*Internal separations  
for the subdivisions of  
the cables/hoses*

---

*Double pin; high strength  
in every condition*

**3**

*Support guide for a correct  
functioning of the chain*

*Inner surface without edges*

*Special end brackets  
will ensure a perfect  
fitting of the chain*

# Serie Robot

## SR495

### Circular Nylon Cable Chain with removable frames

#### Inner height (D) 35 mm

Double share Sideband & Frame construction with large anti-friction single-pin.

Frames removable from inner radius.

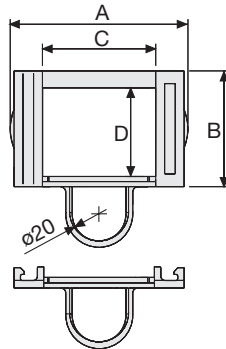

#### Pin

Part.no PG305

#### Technical characteristics

Speed	180°/s
Acceleration	180°/s <sup>2</sup>

For higher requirements please consult our technical dept.

A	B	C	D	R	Weight/pitch	Chain
mm	mm	mm	mm	mm	kg	Part Number
69	45	45	35	100	0,100	SR495

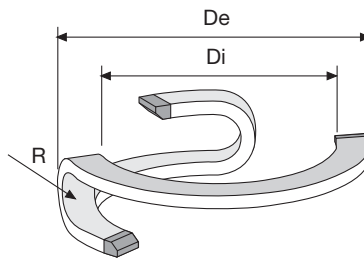

R	Di	De
mm	mm	mm
100	600	755

#### Length of Chain

Chain	Degrees	No
Part Numbers	of Rotation	of Pitches
SR495	90	13
SR495	180	18
SR495	270	22
SR495	360	26





# Serie Robot

## SR500 Circular Nylon Cable Chain with removable frames

### Inner height (D) 30 mm

Double share Sideband & Frame construction with large anti-friction single-pin.  
Frames removable from inner radius.

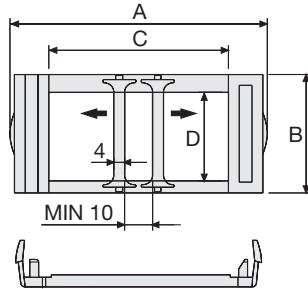

### Separator

- Unassembled	Part.no S500
- Assembled	Part.no S500MC

### Pin

Part.no PG355

### Technical characteristics

Speed	180°/s
Acceleration	180°/s <sup>2</sup>

For higher requirements please consult our technical dept.

A	B	C	D	R	Weight/pitch	Chain
mm	mm	mm	mm	mm	kg	Part Number
93	43	65	30	100	0,135	SR5001
93	43	65	30	150	0,135	SR5002

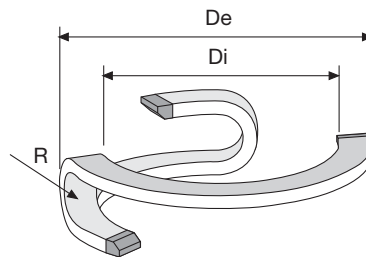

R	Di	De
mm	mm	mm
100	630	830
150	630	830

### Length of Chain

Chain	Degrees	No
Part Numbers	of Rotation	of Pitches
SR5001	90	12
SR5001	180	16
SR5001	270	20
SR5001	360	24
SR5002	90	14
SR5002	180	18
SR5002	270	23
SR5002	360	27





### Steel End Brackets

The end brackets set, containing two steel plates screwed to the links, allows the two ends of the chain to be attached to the equipment. The end brackets are installed in one position offering the possibility of attaching the chain externally. (Fig. A)

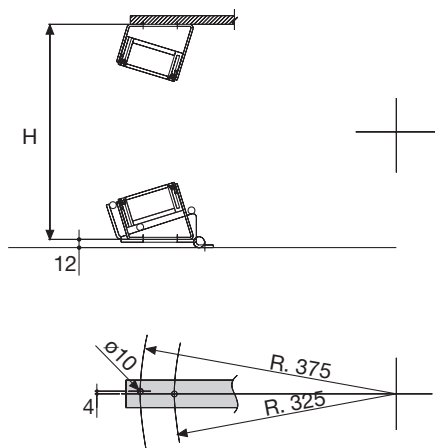

Fig. A

### Support Guide

For correct functioning of the chain it is necessary that the installation is done in a specific position.

For this reason Brevetti Stendalto has observed and created a support guide which can do this. (Fig. B)

For particular applications it is possible to create support guides with attachment plates and special dimensions.

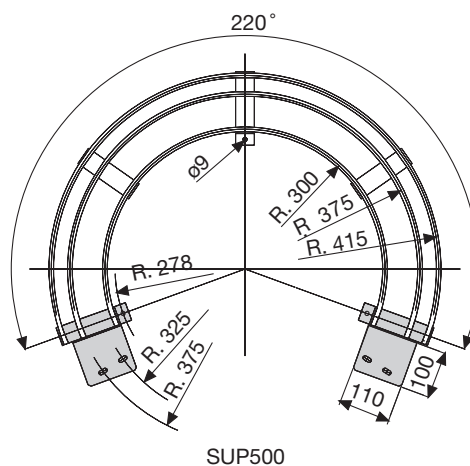

Fig. B

Chain Type	H
SR5001	330
SR5002	410

For applications with rotations exceeding 200° it is necessary to use the appropriate accessories for supporting the cable chain. (see page 28).

### Steel End Brackets Part Numbers

#### Complete Set Assembled

Chain Type	End Brackets Set
SR500...	A500KM

#### Complete Set Unassembled

Chain Type	End Brackets Set
SR500...	A500K

### Serie Robot

## SR500

Circular Nylon Cable Chain with removable frames

# Serie Robot

## SR510TN-SR515TN Circular Nylon Cable Chain with openable frames

### Inner height (D) 46 mm

Double share Sideband & Frame construction with large anti-friction twin-pin.

Frames openable from inner radius.

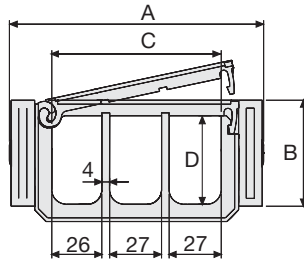

### Pin SR510TN

Part.no PG511

### Pin SR515TN

Part.no PG515-B515

### Technical characteristics

Speed	180°/s
Acceleration	180°/s <sup>2</sup>

For higher requirements please consult our technical dept.

A	B	C	D	R	Weight/pitch	Chain
mm	mm	mm	mm	mm	kg	Part Number
132	55	88	46	125	0,200	SR510TN
132	55	88	46	175	0,200	SR515TN

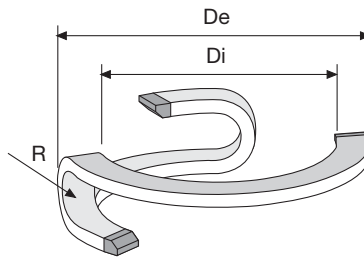

Chain Part Number	R mm	Di mm	De mm
SR510TN	125	940	1220
SR515TN	175	1060	1340

### Length of Chain

Chain Part Numbers	Degrees of Rotation	No of Pitches
SR510TN	90	13
SR510TN	180	17
SR510TN	270	22
SR510TN	360	27
SR515TN	90	13
SR515TN	180	23
SR515TN	270	29
SR515TN	360	35

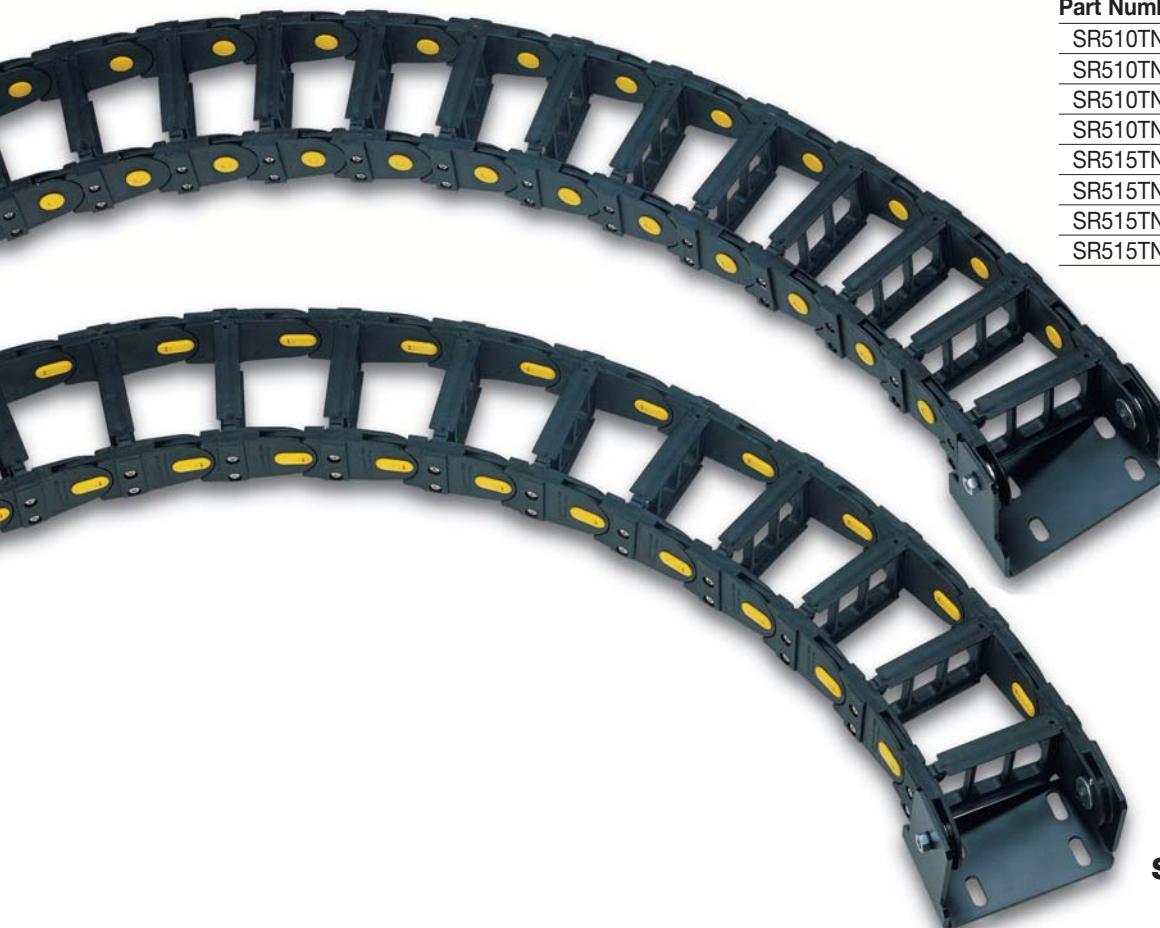

SR515TN

SR510TN

### Steel End Brackets

The end brackets set, containing two steel plates screwed to the links, allows the two ends of the chain to be attached to the equipment. The end brackets are installed in one position offering the possibility of attaching the chain externally. (Fig. A)

#### SR510TN

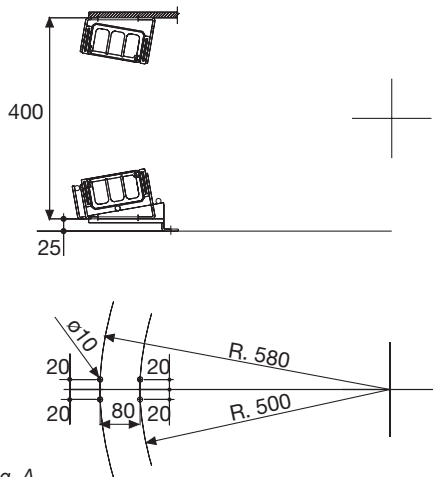

Fig. A

### Support Guide

For correct functioning of the chain it is necessary that the installation is done in a specific position.

For this reason Brevetti Stendalto has observed and created a support guide which can do this. (Fig. B)

For particular applications it is possible to create support guides with attachment plates and special dimensions.

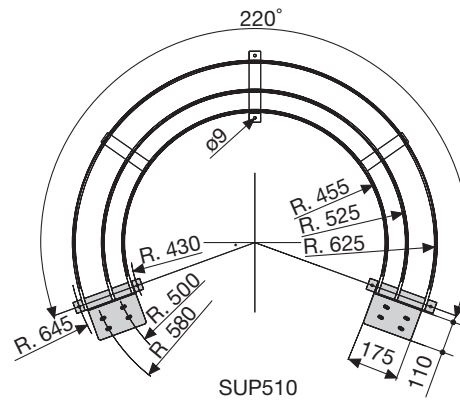

Fig. B

#### SR515TN

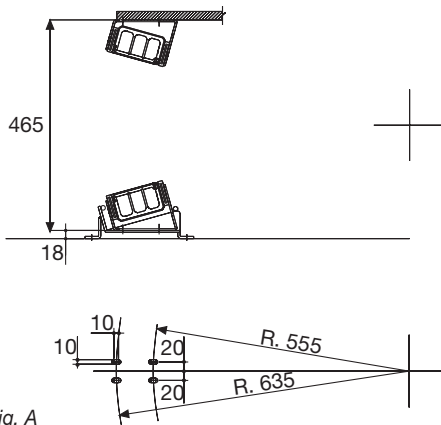

Fig. A

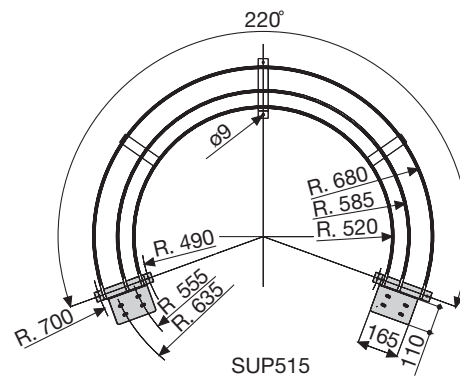

Fig. B

### Steel End Brackets Part Numbers

#### Complete Set Assembled

Chain Type	End Brackets Set
SR510TN	A510TNKM
SR515TN	A515TNKM

#### Complete Set Unassembled

Chain Type	End Brackets Set
SR510TN	A510TNK
SR515TN	A515TNK

For applications with rotations exceeding 200° it is necessary to use the appropriate accessories for supporting the cable chain. (see page 28).

### Serie Robot

## SR510TN

## SR515TN

**Circular Nylon Cable Chain with openable frames**

# Serie Robot

## SR545

### Circular Nylon Cable Chain with openable frames

#### Inner height (D) 46 mm

Double share Sideband & Frame construction with large anti-friction single-pin.

Frames openable from inner radius.

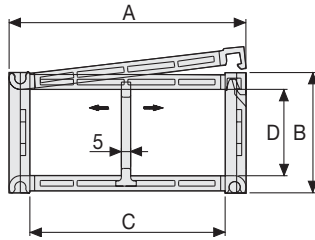

#### Pin

Part.no PG545

#### Technical characteristics

Speed	180°/s
Acceleration	180°/s <sup>2</sup>

For higher requirements please consult our technical dept.

A	B	C	D	R	Weight/pitch	Chain
mm	mm	mm	mm	mm	kg	Part Number
123	62	100	46	100	0,200	SR545SI100100

R	Di	De
mm	mm	mm
100	485	760

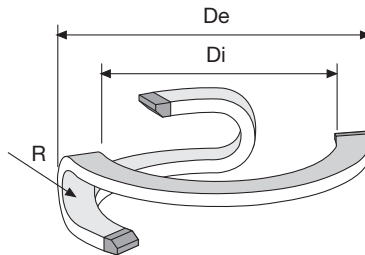

#### Length of Chain

Chain	Degrees	No
Part Numbers	of Rotation	of Pitches
SR545	90	14
SR545	180	18
SR545	270	22
SR545	360	27



## Steel End Brackets

The end brackets set, containing two steel plates screwed to the links, allows the two ends of the chain to be attached to the equipment. The end brackets are installed in one position offering the possibility of attaching the chain externally. (Fig. A)

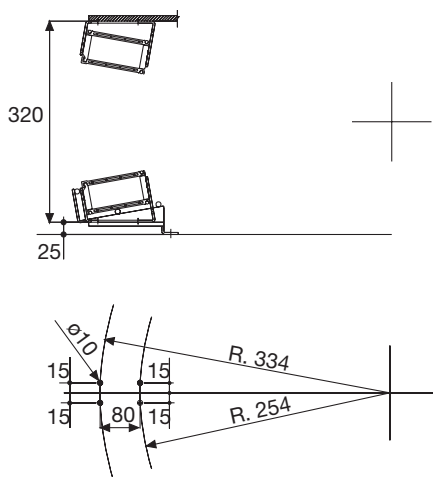

Fig. A

## Support Guide

For correct functioning of the chain it is necessary that the installation is done in a specific position.

For this reason Brevetti Stendalto has observed and created a support guide which can do this. (Fig. B)

For particular applications it is possible to create support guides with attachment plates and special dimensions.

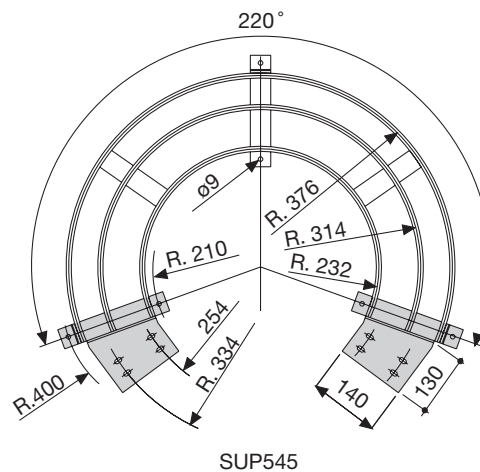

Fig. B

## Steel End Brackets Part Numbers

### Complete Set Assembled

Chain Type	End Brackets Set
SR545	A545KM

### Complete Set Unassembled

Chain Type	End Brackets Set
SR545	A545K

For applications with rotations exceeding 200° it is necessary to use the appropriate accessories for supporting the cable chain. (see page 28).

Serie Robot

## SR545

Circular Nylon Cable Chain  
with openable frames

# Serie Robot

## SR599

### Circular Nylon Cable Chain with un-screwable aluminium frames

#### Inner height (D) 59 mm

Strong double share Sideband & Frame construction with three single-pins in steel for high torsion resistance. Alu-frames are un-screwable from inner and outer radius.

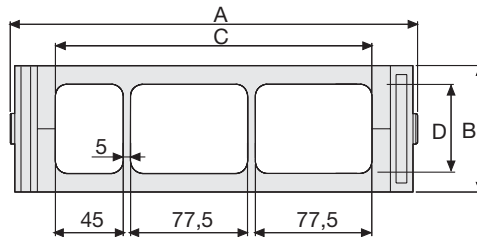

#### Technical characteristics

Speed	180°/s
Acceleration	180°/s <sup>2</sup>

For higher requirements please consult our technical dept.

A	B	C	D	R	Weight/pitch	Chain
mm	mm	mm	mm	mm	kg	Part Number
272	85	210	59	220	0,900	SR599

3

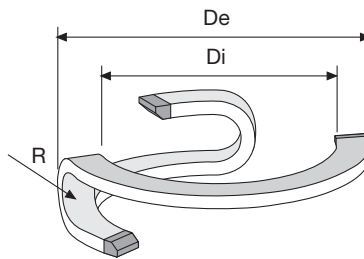

R	Di	De
mm	mm	mm
220	1400	2000

#### Length of Chain

Chain Part Numbers	Degrees of Rotation	No of Pitches
SR599	90	14
SR599	180	19
SR599	270	23
SR599	360	28



Version with horizontal separators

### Steel End Brackets

The end brackets set, containing two steel plates screwed to the links, allows the two ends of the chain to be attached to the equipment. The end brackets are installed in one position offering the possibility of attaching the chain externally. (Fig. A)

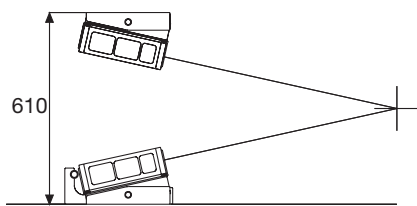

Fig. A

### Support Guide

For correct functioning of the chain it is necessary that the installation is done in a specific position.

For this reason Brevetti Stendalto has observed and created a support guide which can do this. (Fig. B)

For particular applications it is possible to create support guides with attachment plates and special dimensions.

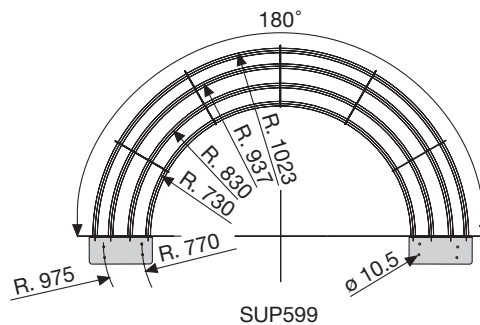

Fig. B

### Steel End Brackets Part Numbers

#### Complete Set Assembled

Chain Type	End Brackets Set
SR599	A599KM

#### Complete Set Unassembled

Chain Type	End Brackets Set
SR599	A599NK

For applications with rotations exceeding 200° it is necessary to use the appropriate accessories for supporting the cable chain. (see page 28).

### Serie Robot

## SR599

**Circular Nylon Cable Chain with un-screwable aluminium frames**

# Separation System

A complete new interior separation system is now available for 10 medium and larger chains. The modular system is based on a range of 12 horizontal separators which are fitted into the vertical separators to create required interior cable separation.

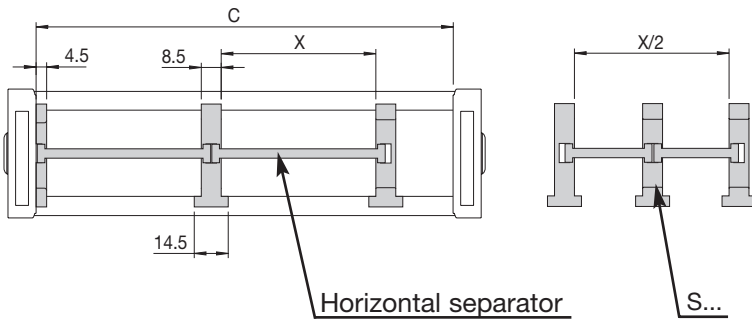

Horizontal Separator Part Number	X mm	X/2
SO01016	16	
SO01025	25	
SO01029	29	
SO01041	41	SO01016 + S... + SO01016
SO01050	50	SO01016 + S... + SO01025
SO01059	59	SO01025 + S... + SO01025
SO01066	66	SO01029 + S... + SO01029
SO01074	74	SO01025 + S... + SO01041
SO01091	91	SO01041 + S... + SO01041
SO01108	108	SO01059 + S... + SO01041
SO01120	120	
SO01140	140	SO01091 + S... + SO01041

## SR445MI/ME

Vertical separator and Vertical-side separator with max 4 slots separation.

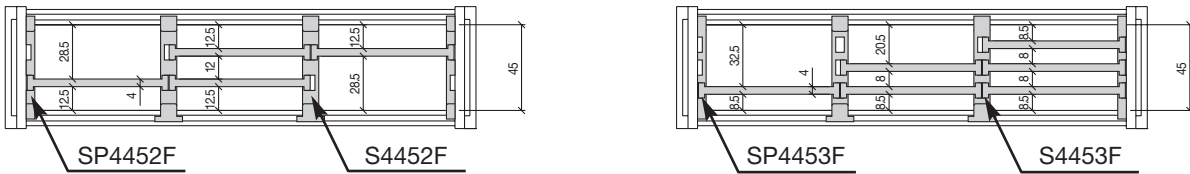

## SR660A - SR306SI/SE

Vertical separator and Vertical-side separator with 2 slots separation.

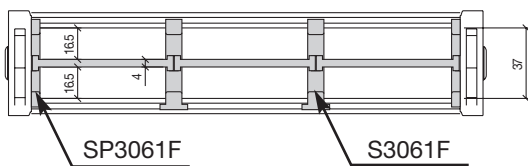

## SR770A

Vertical separator and Vertical-side separator with max. 4 slots separation.

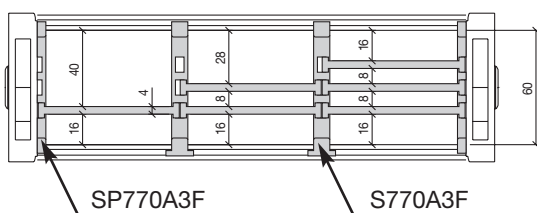



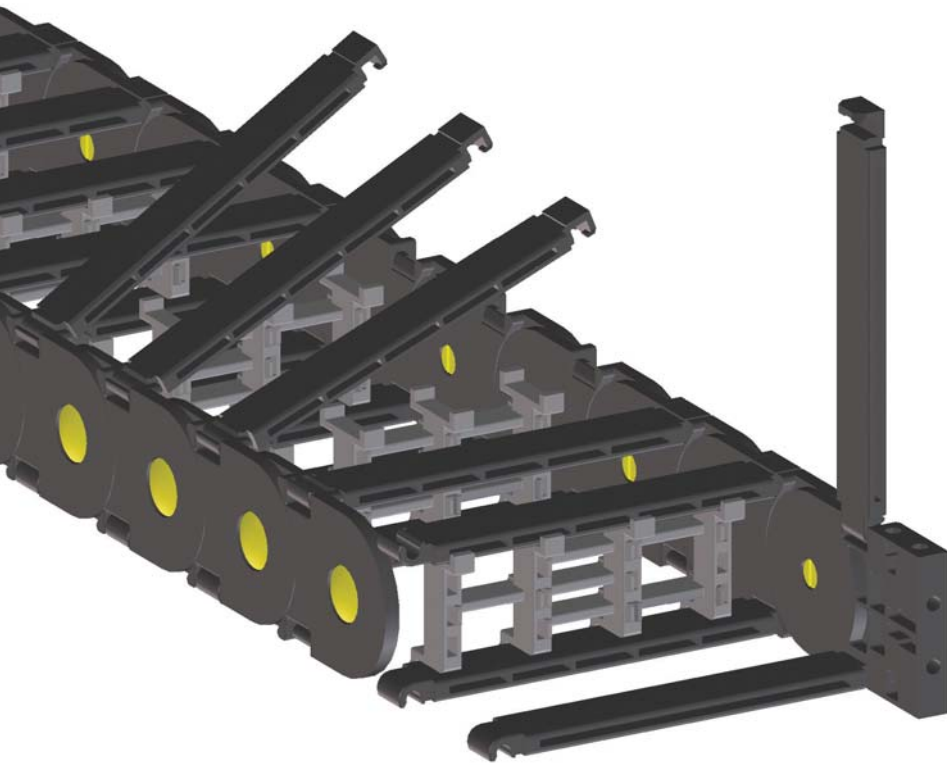

### SR307SI/SE

Vertical separator and Vertical-side separator with max. 4 slots separation.

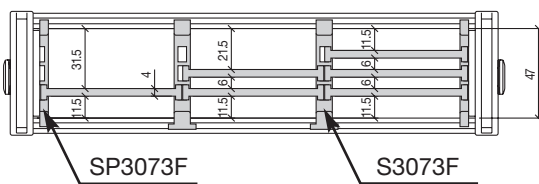

### SR308SI/SE

Vertical separator and Vertical-side separator with max. 4 slots separation.

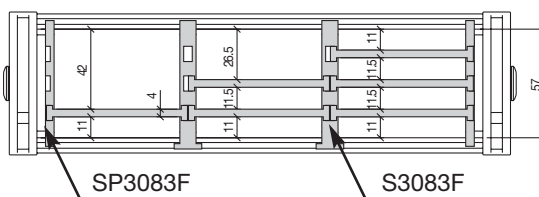

### SR309SI/SE - SR475MI/ME

Vertical separator and Vertical-side separator with max. 6 slots separation.

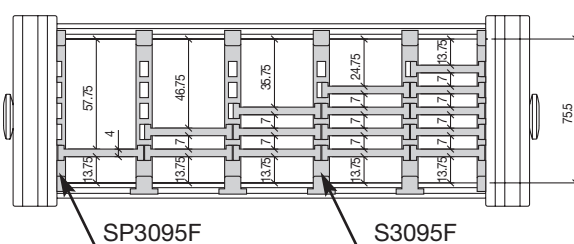

For further information please  
consult Brevetti Stendalto's  
Technical Office

# Steel Cable Chains Steel Series

Series BS2000	page 180
Series BS3000	page 182
Series BS3500	page 184
Series BS3500C	page 186
Series BS4000	page 188
Series BS4500	page 190
Cable drag chains in steel for long travel distance	page 192
Special offshore applications	page 193

*Completely enclosed design  
to protect chain contents from  
steel and wood chips, dust, etc.*



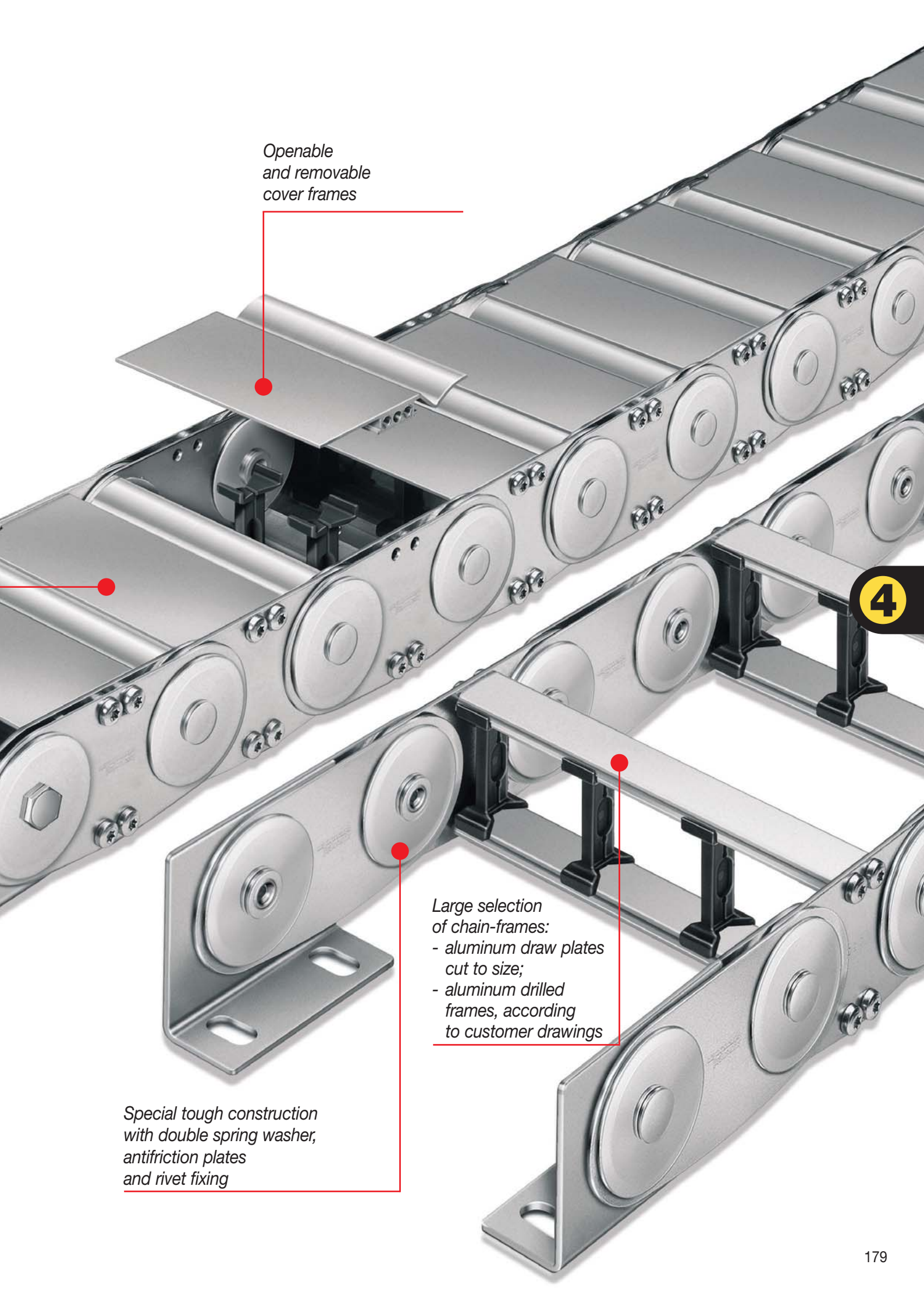

Openable  
and removable  
cover frames

4

Large selection  
of chain-frames:  
- aluminum draw plates  
cut to size;  
- aluminum drilled  
frames, according  
to customer drawings

Special tough construction  
with double spring washer,  
antifriction plates  
and rivet fixing

# Serie Steel

## BS2000

### Cable Chains in Bright Zinc Plated Steel

#### Inner height (D) 32 mm

Double share link construction. Single-rievt fixing and standard large washer and nylon anti-friction disk to assure durable smooth movement. Alu-draw frames (T) or Alu-drilled plates (TL) are un-screwable from both sides. As standard the frames every second link, on request every link. Vertical and horizontal separator systems are available. Also available in Stainless Steel.

#### Technical characteristics when self-supported

Speed	0,5 m/s
Acceleration	2 m/s <sup>2</sup>

For higher requirements please consult our technical dept.

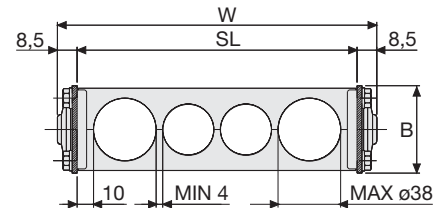
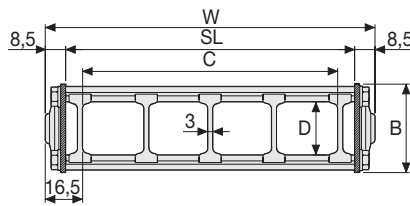

#### Separator

- Unassembled	Part.no S306CO
- Assembled	Part.no S306COMC

#### Aluminium Draw Plates with Separators in Nylon

W	B	C	D	R	Weight/m	Chain
mm	mm	mm	mm	mm	kg	Part Number
112	53	79	32	075-115-150-205-250-305	4,90	2000NT079□□□*
137	53	104	32	075-115-150-205-250-305	5,00	2000NT104□□□*
187	53	154	32	075-115-150-205-250-305	5,30	2000NT154□□□*
237	53	204	32	075-115-150-205-250-305	5,60	2000NT204□□□*
287	53	254	32	075-115-150-205-250-305	5,80	2000NT254□□□*
337	53	304	32	075-115-150-205-250-305	6,10	2000NT304□□□*
C+33	53	....	32	075-115-150-205-250-305		2000NT □□□□□**

\*Complete the code by inserting the value of the radius (R): Ex. 2000NT154 □□□□□

\*\*Complete the code by inserting the value of the quote C and the radius (R): Ex. 2000NT □□□□□□□□  
Chain equipped with aluminium draw plates every pitch: complete the code by inserting the letter D. Ex. 2000NT154250 □

#### Aluminium Split Cross Piece Created by Design

W	B	R	Chain
mm	mm	mm	Part Number
SL+17	53	075-115-150-205-250-305	2000NTL □□□□□□***

\*\*\*Complete the code by inserting the value SL and the radius (R): Ex. 2000NTL □□□□□□□□□□

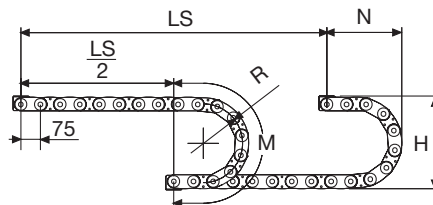

R	H*	N	M
mm	mm	mm	mm
075	214	180	390
115	294	220	515
150	364	255	625
205	474	310	795
250	564	360	940
305	674	410	1110

\* The total space taken in height may vary in relationship to the pre-set up to 10 mm/m.

Length of chain (L)

Half travel distance ( $\frac{LS}{2}$ )  
plus length of curve (M)

$$L = \frac{LS}{2} + M$$



### Self-Supporting Capacity Diagram

The maximum length of the self-supporting capacity ( $\frac{LS}{2}$ ) in relationship to the weight of the cables and hoses contained per linear metre.

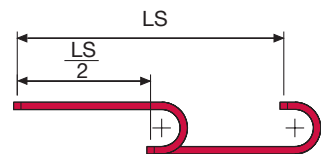
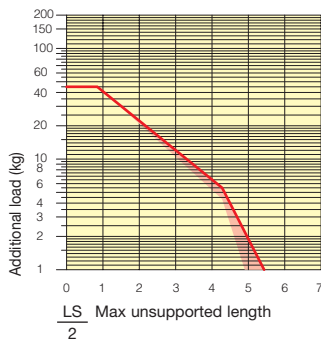

The red marking in the diagram area considers the difference of weight between various widths of chains assembled with aluminium draw plates every second pitch.

For applications with  $\frac{LS}{2}$  and weights not included in the area of the diagram showing self-supporting capacity, verify the possible use of support rollers (see page 30).

### Bright Zinc Plated Steel End Brackets

The end brackets set, containing four steel plates screwed to the links allows the two ends of the chain to be attached to the equipment.

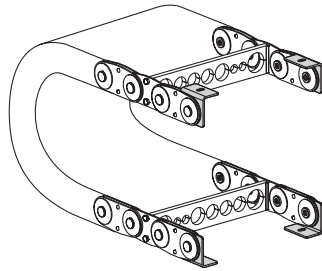
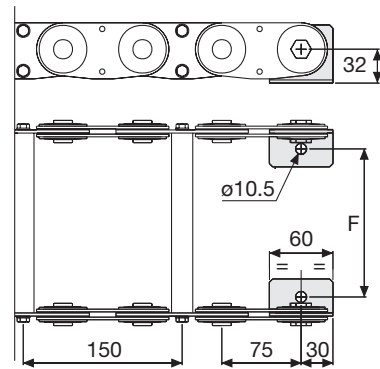

Fig. A  
The chain can be fixed frontally, inner or outer radius. (Fig A)



Chain Type	F mm
BS2000NT079	65
BS2000NT104	90
BS2000NT154	140
BS2000NT204	190
BS2000NT254	240
BS2000NT304	290

Special dimension F=W-47

### Bright Zinc Plated Steel Type Part Numbers

Complete Set Assembled	
Chain Type	End Brackets Set
BS2000...	A2000NKM

Complete Set Unassembled	
Chain Type	End Brackets Set
BS2000...	A2000NK

### Serie Steel

## BS2000

Cable Chain  
in Bright Zinc Plated Steel

4

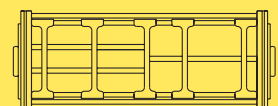

Supplementary movable separators.

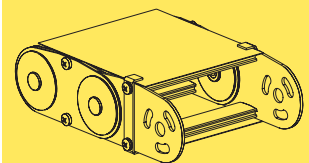

Steel laminar cover.

For further information please consult Brevetti Stendalto's Technical Office

# Serie Steel

## BS3000

### Cable Chains in Bright Zinc Plated Steel

#### Inner height (D) 52 mm

Double share link construction. Single-rievt fixing and standard large washer and nylon anti-friction disk to assure durable smooth movement. Alu-draw frames (T) or Alu-drilled plates (TL) are un-screwable from both sides. As standard the frames every second link, on request every link. Vertical and horizontal separator systems are available. Also available in Stainless Steel.

#### Technical characteristics when self-supported

Speed	0,5 m/s
Acceleration	2 m/s <sup>2</sup>

For higher requirements please consult our technical dept.

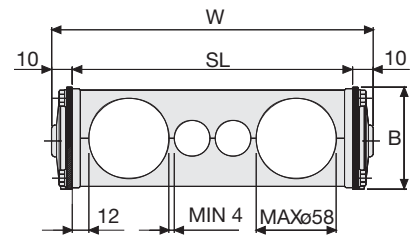
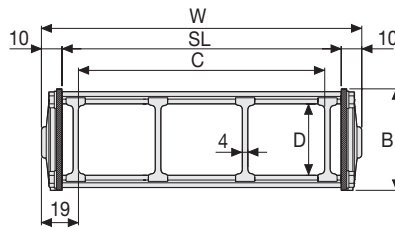

#### Separator

- Unassembled	Part.no S308CO
- Assembled	Part.no S308COMC

#### Aluminium Draw Plates with Separators in Nylon

W	B	C	D	R	Weight/m	Chain
mm	mm	mm	mm	mm	kg	Part Number
144	74	106	52	150-220-250-305-400-535	7,40	3000NT106□□□*
194	74	156	52	150-220-250-305-400-535	7,60	3000NT156□□□*
244	74	206	52	150-220-250-305-400-535	7,80	3000NT206□□□*
294	74	256	52	150-220-250-305-400-535	8,00	3000NT256□□□*
344	74	306	52	150-220-250-305-400-535	8,20	3000NT306□□□*
C+38	74	....	52	150-220-250-305-400-535		3000NT □□□□□**

\*Complete the code by inserting the value of the radius (R): Ex. 3000NT156 □□□□

\*\*Complete the code by inserting the value of the quote C and the radius (R): Ex. 3000NT □□□□□□□□  
Chain equipped with aluminium draw plates every pitch: complete the code by inserting the letter D.  
Ex. 3000NT156250 □□

#### Aluminium Split Cross Piece Created by Design

W	B	R	Chain
mm	mm	mm	Part Number
SL+20	74	150-220-250-305-400-535	3000NTL □□□□□□ ***

\*\*\*Complete the code by inserting the value SL and the radius (R): Ex. 3000NTL □□□□□□□□□□

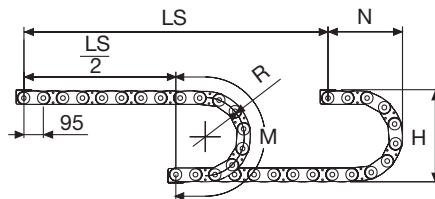

R	H*	N	M
mm	mm	mm	mm
150	388	290	670
220	528	360	890
250	588	385	980
305	698	440	1150
400	888	540	1450
535	1158	675	1880

\* The total space taken in height may vary in relationship to the pre-set up to 10 mm/m.

Length of chain (L)

Half travel distance ( $\frac{LS}{2}$ )  
plus length of curve (M)

$$L = \frac{LS}{2} + M$$



### Self-Supporting Capacity Diagram

The maximum length of the self-supporting capacity ( $\frac{LS}{2}$ ) in relationship to the weight of the cables and hoses contained per linear metre.

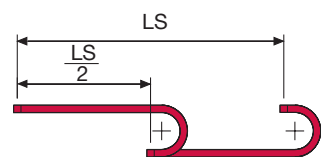
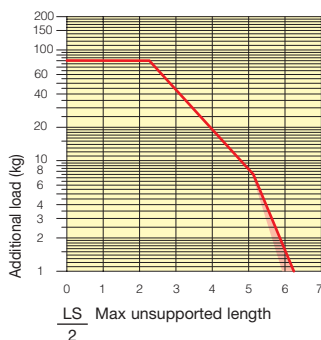

The red marking in the diagram area considers the difference of weight between various widths of chains assembled with aluminium draw plates every second pitch.

For applications with  $\frac{LS}{2}$  and weights not included in the area of the diagram showing self-supporting capacity, verify the possible use of support rollers (see page 30).

### Bright Zinc Plated Steel End Brackets

The end brackets set, containing four steel plates screwed to the links allows the two ends of the chain to be attached to the equipment.

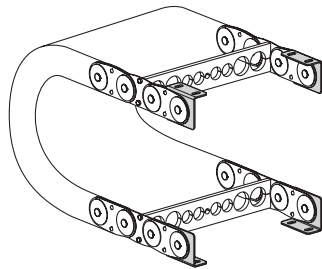
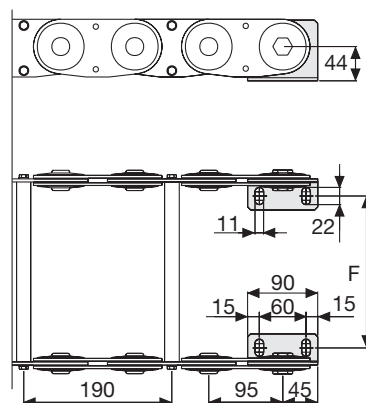

Fig. A  
The chain can be fixed frontally, inner or outer radius. (Fig A)



Chain Type	F mm
BS3000NT106	88
BS3000NT156	138
BS3000NT206	188
BS3000NT256	238
BS3000NT306	288

Special dimension F=W-56

### Bright Zinc Plated Steel Type Part Numbers

Complete Set Assembled	
Chain Type	End Brackets Set
BS3000...	A3000NKM

Complete Set Unassembled	
Chain Type	End Brackets Set
BS3000...	A3000NK

### Serie Steel

## BS3000 Cable Chain in Bright Zinc Plated Steel

4

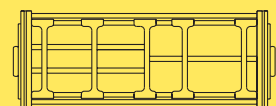

Supplementary movable separators.

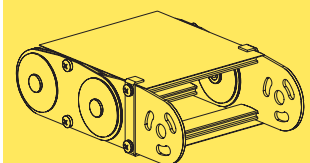

Steel laminar cover.

For further information please consult Brevetti Stendalto's Technical Office

# Serie Steel

## BS3500

### Cable Chains in Bright Zinc Plated Steel

#### Inner height (D) 65 mm

Double share link construction. Single-rivet fixing and standard large washer and nylon anti-friction disk to assure durable smooth movement. Alu-draw frames (T) or Alu-drilled plates (TL) are un-screwable from both sides. As standard the frames every second link, on request every link. Vertical and horizontal separator systems are available. Also available in Stainless Steel.

#### Technical characteristics when self-supported

Speed	0,5 m/s
Acceleration	2 m/s <sup>2</sup>

For higher requirements please consult our technical dept.

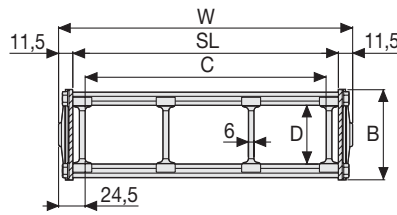

#### Separator

- Unassembled Part.no ST3500F
- Assembled Part.no ST3500FMC

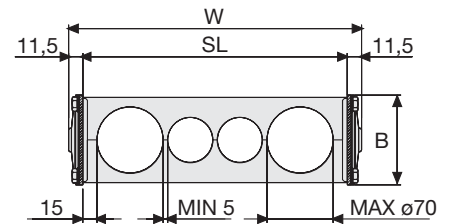

#### Aluminium Draw Plates with Separators in Nylon

W	B	C	D	R	Weight/m	Chain
mm	mm	mm	mm	mm	kg	Part Number
153	95	104	65	200-250-300-350-400-450-500-600	12,00	3500NT104□□□*
203	95	154	65	200-250-300-350-400-450-500-600	12,30	3500NT154□□□*
253	95	204	65	200-250-300-350-400-450-500-600	12,70	3500NT204□□□*
303	95	254	65	200-250-300-350-400-450-500-600	13,00	3500NT254□□□*
353	95	304	65	200-250-300-350-400-450-500-600	13,30	3500NT304□□□*
453	95	404	65	200-250-300-350-400-450-500-600	14,00	3500NT404□□□*
C+49	95	....	65	200-250-300-350-400-450-500-600		3500NT □□□□□**

\*Complete the code by inserting the value of the radius (R): Ex. 3500NT154 [2] [5] [0]

\*\*Complete the code by inserting the value of the quote C and the radius (R): Ex. 3500NT [7] [2] [3] [2] [5] [0]  
Chain equipped with aluminium draw plates every pitch: complete the code by inserting the letter D.  
Ex. 3500NT154250 [D]

#### Aluminium Split Cross Piece Created by Design

W	B	R	Chain
mm	mm	mm	Part Number
SL+23	95	200-250-300-350-400-450-500-600	3500NTL □□□□□***

\*\*\*Complete the code by inserting the value SL and the radius (R): Ex. 3500NTL [7] [5] [0] [2] [5] [0]

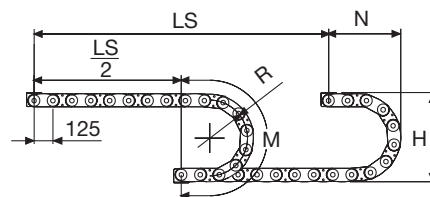

Length of chain (L)  
Half travel distance ( $\frac{LS}{2}$ )  
plus length of curve (M)

$$L = \frac{LS}{2} + M$$

R	H*	N	M
mm	mm	mm	mm
200	512	375	880
250	612	425	1040
300	712	480	1200
350	812	525	1350
400	912	575	1510
450	1012	625	1670
500	1112	675	1825
600	1312	775	2140

\* The total space taken in height may vary in relationship to the pre-set up to 10 mm/m.





### Self-Supporting Capacity Diagram

The maximum length of the self-supporting capacity ( $\frac{LS}{2}$ ) in relationship to the weight of the cables and hoses contained per linear metre.

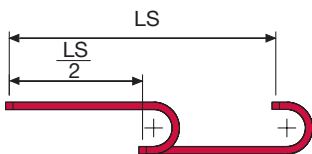
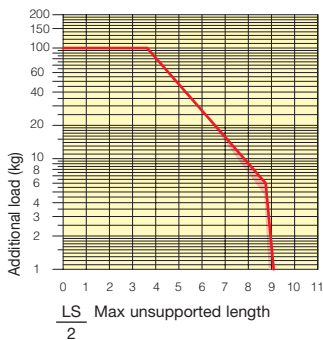

The red marking in the diagram area considers the difference of weight between various widths of chains assembled with aluminium draw plates every second pitch.

For applications with  $\frac{LS}{2}$  and weights not included in the area of the diagram showing self-supporting capacity, verify the possible use of support rollers (see page 30).

### Bright Zinc Plated Steel End Brackets

The end brackets set, containing four steel plates screwed to the links allows the two ends of the chain to be attached to the equipment.

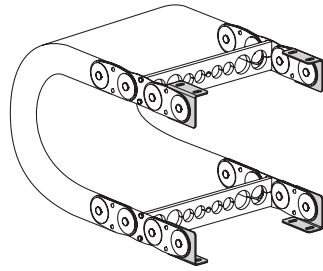
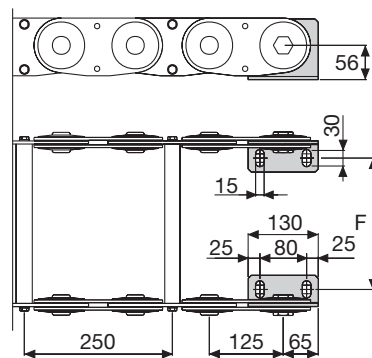

Fig. A  
The chain can be fixed frontally, inner or outer radius. (Fig A)



Chain Type	F mm
BS3500NT104	80
BS3500NT154	130
BS3500NT204	180
BS3500NT254	230
BS3500NT304	280
BS3500NT404	380

Special dimension F=W-73

### Bright Zinc Plated Steel Type Part Numbers

Complete Set Assembled	
Chain Type	End Brackets Set
BS3500...	A3500NKM

Complete Set Unassembled	
Chain Type	End Brackets Set
BS3500...	A3500NK

### Serie Steel

## BS3500

Cable Chain  
in Bright Zinc Plated Steel

4

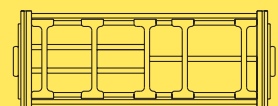

Supplementary movable separators.

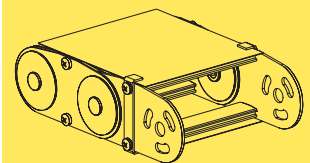

Steel laminar cover.

For further information please consult Brevetti Stendalto's Technical Office

# Serie Steel

## BS3500C

### Cable Chains in Bright Zinc Plated Steel

#### Inner height (D) 65 mm

Double share link construction.  
Single-rievet fixing and standard large washer and nylon anti-friction disk to assure smooth and durable movement.  
The strong Alu-covers are un-screwable from both sides.  
Vertical and horizontal separator systems are available.

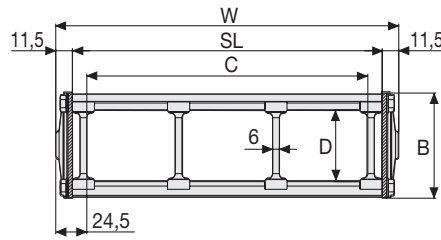

#### Separator

- Unassembled	Part.no ST3500F
- Assembled	Part.no ST3500FMC

#### Technical characteristics when self-supported

Speed	0,5 m/s
Acceleration	2 m/s <sup>2</sup>

For higher requirements please consult our technical dept.

#### Aluminium Draw Plates with Separators in Nylon

W	B	C	D	R	Weight/m	Chain
mm	mm	mm	mm	mm	kg	Part Number
153	95	104	65	200-250-300-350-400-450-500-600	13,80	3500NC104□□□*
203	95	154	65	200-250-300-350-400-450-500-600	14,80	3500NC154□□□*
253	95	204	65	200-250-300-350-400-450-500-600	15,80	3500NC204□□□*
303	95	254	65	200-250-300-350-400-450-500-600	16,80	3500NC254□□□*
353	95	304	65	200-250-300-350-400-450-500-600	17,80	3500NC304□□□*
453	95	404	65	200-250-300-350-400-450-500-600	19,80	3500NC404□□□*
C+49	95	....	65	200-250-300-350-400-450-500-600		3500NC □□□□□**

\*Complete the code by inserting the value of the radius (R): Ex. 3500NC154 [2] [5] [0]

\*\*Complete the code by inserting the value of the quote C and the radius (R): Ex. 3500NC [1] [2] [3] [2] [5] [0]

4

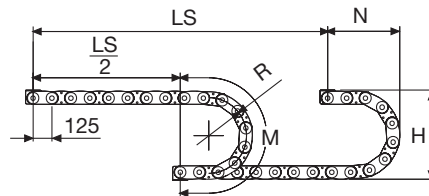

Length of chain (L)  
Half travel distance ( $\frac{LS}{2}$ )  
plus length of curve (M)

$$L = \frac{LS}{2} + M$$

R	H*	N	M
mm	mm	mm	mm
200	512	375	880
250	612	425	1040
300	712	480	1200
350	812	525	1350
400	912	575	1510
450	1012	625	1670
500	1112	675	1825
600	1312	775	2140

\* The total space taken in height may vary in relationship to the pre-set up to 10 mm/m.

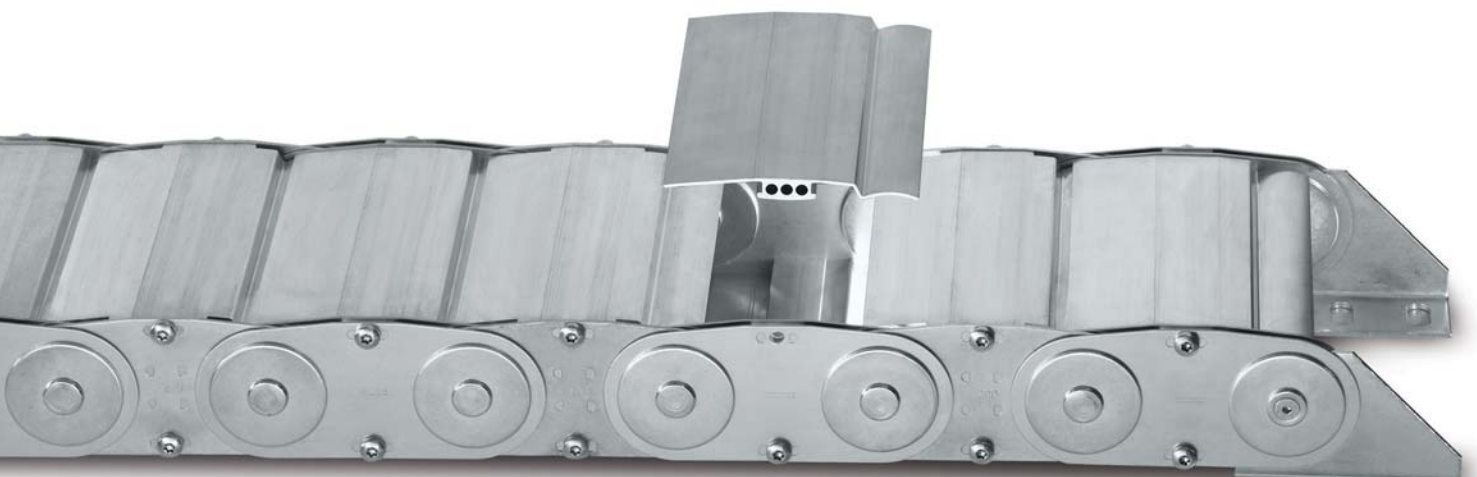

### Self-Supporting Capacity Diagram

The maximum length of the self-supporting capacity ( $\frac{LS}{2}$ ) in relationship to the weight of the cables and hoses contained per linear metre.

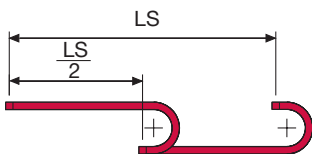
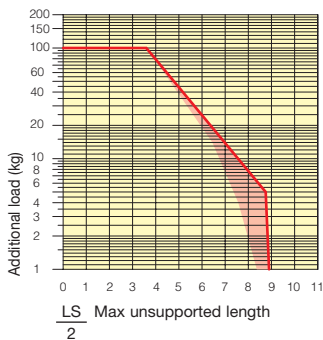

The red marking in the diagram area considers the difference of weight between various widths of chain.

For applications with  $\frac{LS}{2}$  and weights not included in the area of the diagram showing self-supporting capacity, verify the possible use of support rollers (see page 30).

### Bright Zinc Plated Steel End Brackets

The end brackets set, containing four steel plates screwed to the links allows the two ends of the chain to be attached to the equipment.

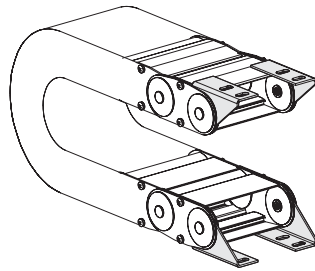
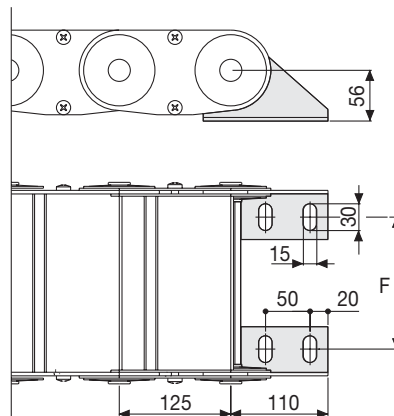

Fig. A  
Chain fixed outside the radius. (Fig A)



Chain Type	F mm
BS3500NC104	80
BS3500NC154	130
BS3500NC204	180
BS3500NC254	230
BS3500NC304	280
BS3500NC404	380

Special dimension F=W-73

### Bright Zinc Plated Steel Type Part Numbers

Complete Set Assembled	
Chain	End Brackets
Type	Set
BS3500C...	A3500NCKM □**

Complete Set Unassembled	
Chain	End Brackets
Type	Set
BS3500C...	A3500NCK

\*\* 1=Pos.1; 2=Pos.2; 3=Pos.3  
See end brackets mounting variations page 31.

Serie Steel

## BS3500C

Cable Chain  
in Bright Zinc Plated Steel

# Serie Steel

# BS4000

## Cable Chains in Bright Zinc Plated Steel

### Inner height (D) 112,5 mm

Double share link construction. Triple-rivet fixing and standard large washer and nylon anti-friction disk to assure smooth and durable movement. Un-screwable Alu-draw frames (T) are standard mounted and every link. Alu-drilled plates (TL) are mounted every second link with an Alu-draw frames every other link. Separator systems available. Also available in Stainless Steel.

### Technical characteristics when self-supported

Speed	0,5 m/s
Acceleration	2 m/s <sup>2</sup>

For higher requirements please consult our technical dept.

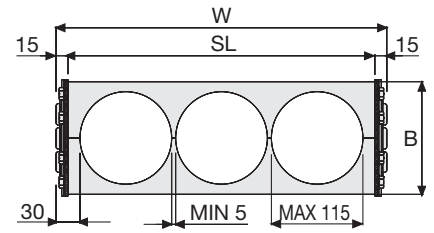
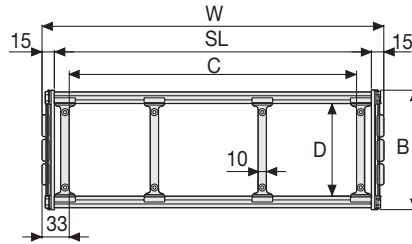

### Separator

- Unassembled Part.no S310TC
- Assembled Part.no S310TMC

### Aluminium Draw Plates with Separators in Nylon

W	B	C	D	R	Weight/m	Chain
mm	mm	mm	mm	mm	kg	Part Number
216	145	150	112,5	250-300-350-400-450-500-550-600-700-750-850-1000	20,60	4000T150□□□□*
266	145	200	112,5	250-300-350-400-450-500-550-600-700-750-850-1000	21,70	4000T200□□□□*
316	145	250	112,5	250-300-350-400-450-500-550-600-700-750-850-1000	23,10	4000T250□□□□*
366	145	300	112,5	250-300-350-400-450-500-550-600-700-750-850-1000	24,40	4000T300□□□□*
466	145	400	112,5	250-300-350-400-450-500-550-600-700-750-850-1000	27,20	4000T400□□□□*
566	145	500	112,5	250-300-350-400-450-500-550-600-700-750-850-1000	29,90	4000T500□□□□*
C+66	145	....	112,5	250-300-350-400-450-500-550-600-700-750-850-1000		4000T □□□□□□**

\*Complete the code by inserting the value of the radius (R): Ex. 4000T150 [2][5][0]

\*\*Complete the code by inserting the value of the quote C and the radius (R): Ex. 4000T [7][2][8][2][5][0]

### Aluminium Split Cross Piece Created by Design

W	B	R	Chain
mm	mm	mm	Part Number
SL+30	145	250-300-350-400-450-500-550-600-700-750-850-1000	4000TL □□□□□□***

\*\*\*Complete the code by inserting the value SL and the radius (R): Ex. 4000TL [7][5][0][2][5][0]

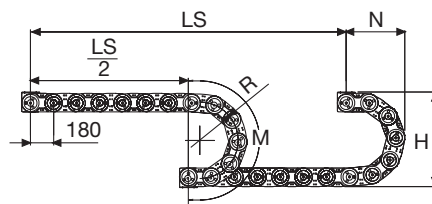

R	H*	N	M
mm	mm	mm	mm
250	670	510	1150
300	770	555	1305
350	870	605	1460
400	970	655	1620
450	1070	710	1780
500	1170	755	1930
550	1270	805	2090
600	1370	855	2245
700	1570	955	2560
750	1670	1010	2720
850	1870	1105	3030
1000	2170	1255	3500

\* The total space taken in height may vary in relationship to the pre-set up to 10 mm/m.

Length of chain (L)  
 Half travel distance ( $\frac{LS}{2}$ )  
 plus length of curve (M)

$$L = \frac{LS}{2} + M$$



### Self-Supporting Capacity Diagram

The maximum length of the self-supporting capacity ( $\frac{LS}{2}$ ) in relationship to the weight of the cables and hoses contained per linear metre.

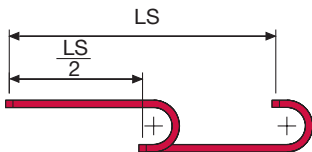
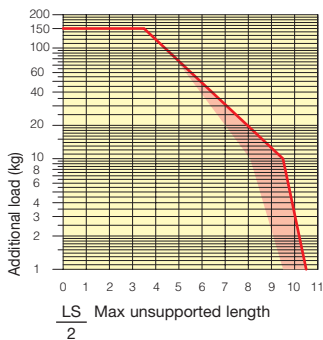

The red marking in the diagram area considers the difference of weight between various widths of chains assembled with aluminium draw plates every second pitch.

For applications with  $\frac{LS}{2}$  and weights not included in the area of the diagram showing self-supporting capacity, verify the possible use of support rollers (see page 30).

### Bright Zinc Plated Steel End Brackets

The end brackets set, containing four steel plates screwed to the links allows the two ends of the chain to be attached to the equipment.

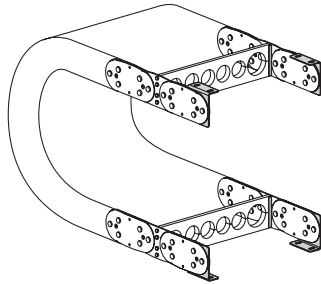
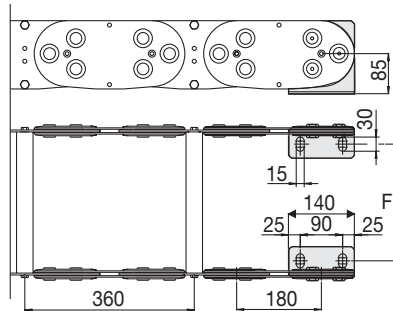

Fig. A  
Chain fixed outside the radius. (Fig A)  
See end brackets mounting variations page 31.



Chain Type	F mm
BS4000T150	136
BS4000T200	186
BS4000T250	236
BS4000T300	286
BS4000T400	386
BS4000T500	486

Special dimension F=W-80

### Bright Zinc Plated Steel Type Part Numbers

Complete Set Assembled	
Chain Type	End Brackets Set
BS4000...	A4000KM □**

Complete Set Unassembled	
Chain Type	End Brackets Set
BS4000...	A4000K

\*\* 1=Pos.1; 2=Pos.2; 3=Pos.3  
See end brackets mounting variations page 31.

### Serie Steel

## BS4000

Cable Chain  
in Bright Zinc Plated Steel

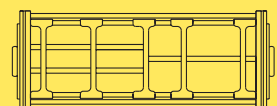

Supplementary movable separators.

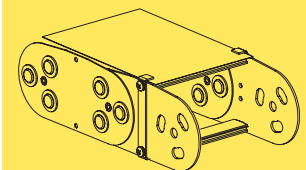

Steel laminar cover.

For further information please consult Brevetti Stendalto's Technical Office

# Serie Steel

# BS4500

## Cable Chains in Bright Zinc Plated Steel

### Inner height (D) 182 mm

Double share link construction.  
Triple-ribose fixing and standard large washer and nylon anti-friction disk to assure smooth and durable movement. Un-screwable Alu-draw frames (T) are standard mounted and every link. Alu-drilled plates (TL) are mounted every second link with an Alu-draw frames every other link. Separator systems available. Also available in Stainless Steel.

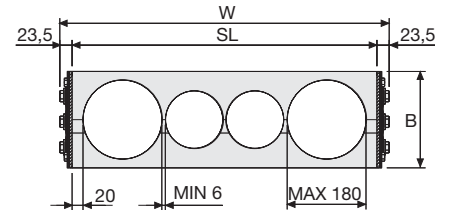
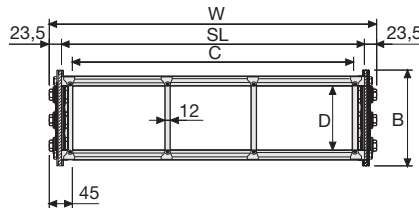

### Separator

- Unassembled Part.no ST4500C
- Assembled Part.no ST4500CMC

### Aluminium Draw Plates with Separators in Nylon

W	B	C	D	R	Weight/m	Chain
mm	mm	mm	mm	mm	kg	Part Number
390	220	300	182	400-600-800-1000-1250-1500	46,5	4500T300□□□□*
440	220	350	182	400-600-800-1000-1250-1500	47,5	4500T350□□□□*
490	220	400	182	400-600-800-1000-1250-1500	48,5	4500T400□□□□*
540	220	450	182	400-600-800-1000-1250-1500	49,0	4500T450□□□□*
590	220	500	182	400-600-800-1000-1250-1500	49,5	4500T500□□□□*
690	220	600	182	400-600-800-1000-1250-1500	51,0	4500T600□□□□*
C+90	220	....	182	400-600-800-1000-1250-1500		4500T□□□□□□**

\*Complete the code by inserting the value of the radius (R): Ex. 4500T300 □□□□

\*\*Complete the code by inserting the value of the quote C and the radius (R): Ex. 4500T □□□□□□

### Technical characteristics when self-supported

Speed	0,5 m/s
Acceleration	2 m/s <sup>2</sup>

For higher requirements please consult our technical dept.

4

### Aluminium Split Cross Piece Created by Design

W	B	R	Chain
mm	mm	mm	Part Number
SL+47	220	400-600-800-1000-1250-1500	4500TL □□□□□□***

\*\*\*Complete the code by inserting the value SL and the radius (R): Ex. 4500TL □□□□□□

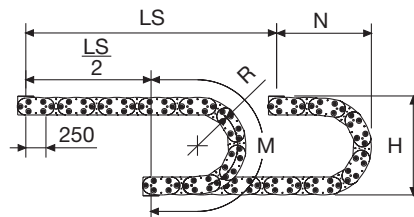

Length of chain (L)  
Half travel distance ( $\frac{LS}{2}$ )  
plus length of curve (M)

$$L = \frac{LS}{2} + M$$

R	H*	N	M
mm	mm	mm	mm
400	1060	770	1760
600	1460	970	2390
800	1860	1170	3020
1000	2260	1370	3650
1250	2760	1620	4430
1500	3260	1870	5220

\* The total space taken in height may vary in relationship to the pre-set up to 10 mm/m.

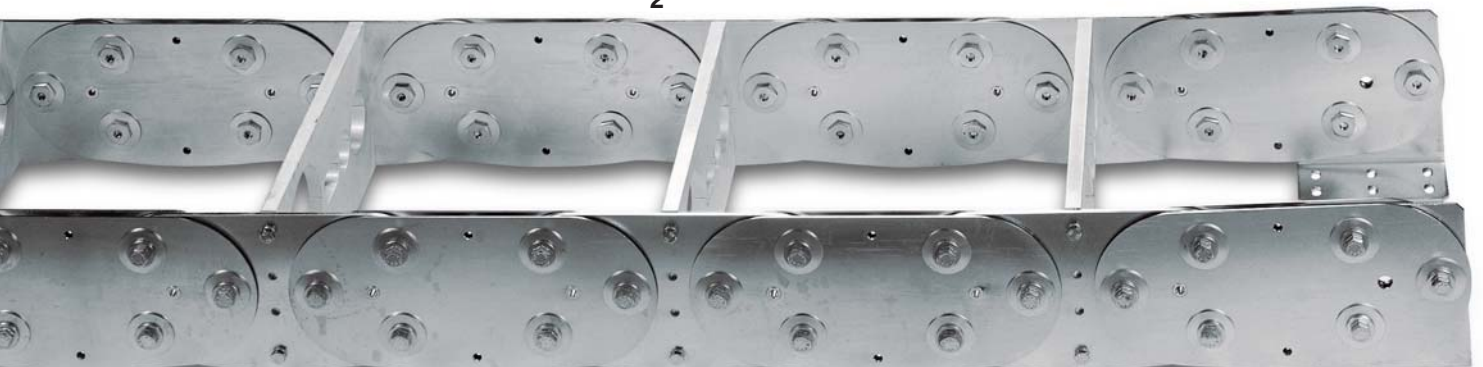

### Self-Supporting Capacity Diagram

The maximum length of the self-supporting capacity ( $\frac{LS}{2}$ ) in relationship to the weight of the cables and hoses contained per linear metre.

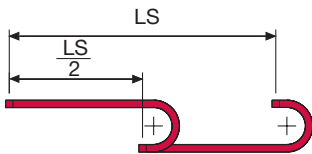
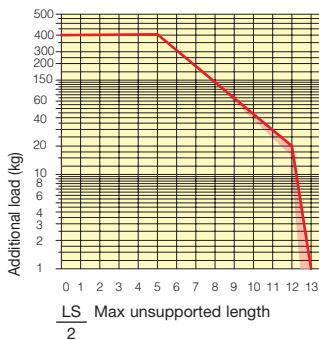

The red marking in the diagram area considers the difference of weight between various widths of chains assembled with aluminium draw plates every second pitch.

For applications with  $\frac{LS}{2}$  and weights not included in the area of the diagram showing self-supporting capacity, verify the possible use of support rollers (see page 30).

### Bright Zinc Plated Steel End Brackets

The end brackets set, containing four steel plates screwed to the links allows the two ends of the chain to be attached to the equipment.

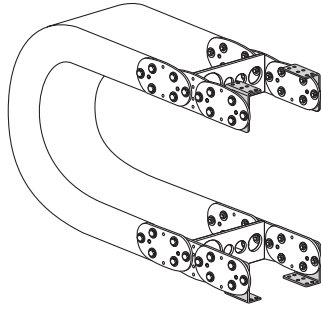
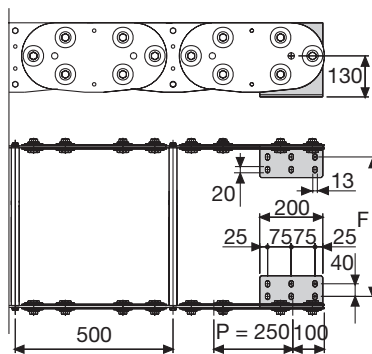

Fig. A  
Chain fixed outside the radius. (Fig A)  
See end brackets mounting variations page 31.



Chain Type	F mm
BS4500T300	285
BS4500T350	335
BS4500T400	385
BS4500T450	435
BS4500T500	485
BS4500T600	585

Special dimension F=W-105

### Bright Zinc Plated Steel Type Part Numbers

Complete Set Assembled	
Chain Type	End Brackets Set
BS4500...	A4500KM □ **

Complete Set Unassembled	
Chain Type	End Brackets Set
BS4500...	A4500K

\*\* 1=Pos.1; 2=Pos.2; 3=Pos.3  
See end brackets mounting variations page 31.

### Serie Steel

## BS4500

Cable Chain  
in Bright Zinc Plated Steel

4

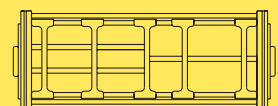

Supplementary movable separators.

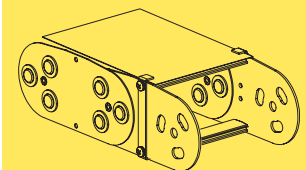

Steel laminar cover.

For further information please consult Brevetti Stendalto's Technical Office

# Cable Drag Chains in Steel for Long Travel Distance

The use of cable chains in applications with particularly long travel distances offers many benefits. The possibilities of the combined transportation of high power cables, signal cables and hydraulic hoses, together with ease of use and no need for maintenance, are the unquestionable advantages of the system. Specific applications, characterised by particularly aggressive conditions in the environment, require cable chains in steel. Brevetti Stendalto has offered for many years, with positive results their own system based on the use of two steel drag chains and a travelling internal supporting frame. The chains are arranged in a closed loop configuration, having

a fixed bracket and a movable towing bracket. A secondary similar closed loop, made of steel wire rope, drives the supporting frame along the entire travel at a suitable speed, thus ensuring a continuous support to relieve all stresses. In addition to this a trough is arranged to contain and guide the chain system along the total travel. The chains are fitted with wheels on ball bearings, to keep to a minimum the friction on the supporting frame. The supporting frame can be made both in galvanised steel, or if requested, in stainless steel.

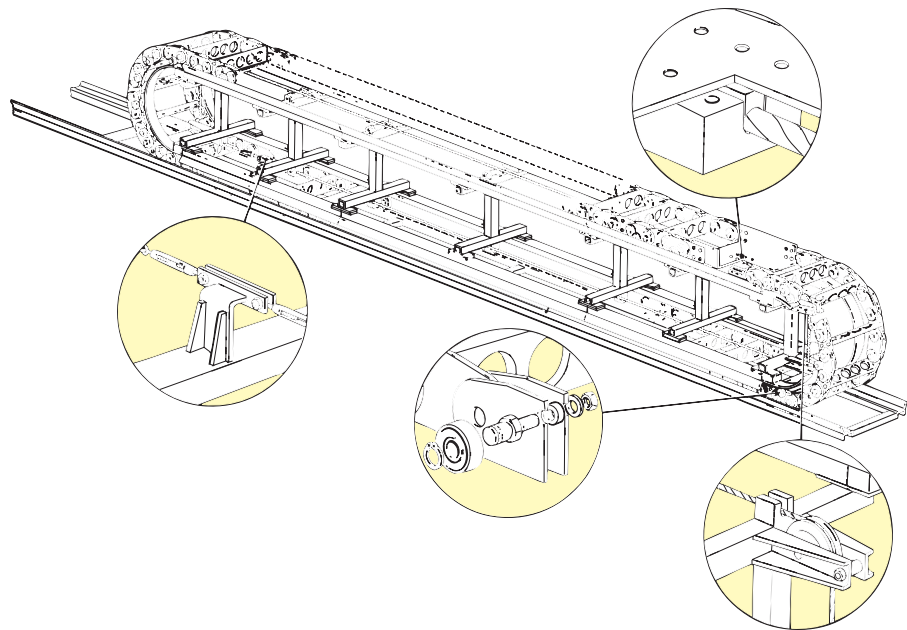

*BS3500 chains with supporting frame applied to De Icing equipment at München airport (Germany). The length of the travel distance is 90m and it's velocity is 90m per minute.*





# Special off-shore Applications

The Brevetti Stendalto steel cable chains have been used in Off-shore applications for many years. The high standard of quality required and the special materials needed are characteristics in these kinds of applications.

On request cable chains of special dimensions which have been personalised according to the clients needs are being used.



Platform "Oseberg"

A: BS4500 chain in stainless steel 316L

B: BS4500 chain in stainless steel 316L for rotations of  $\pm 180^\circ$



Platform "Tiffany"

Specially designed chains in stainless steel 316L  
 Length of travel distance: 27m  
 Total weight of the chains: 13 Ton.

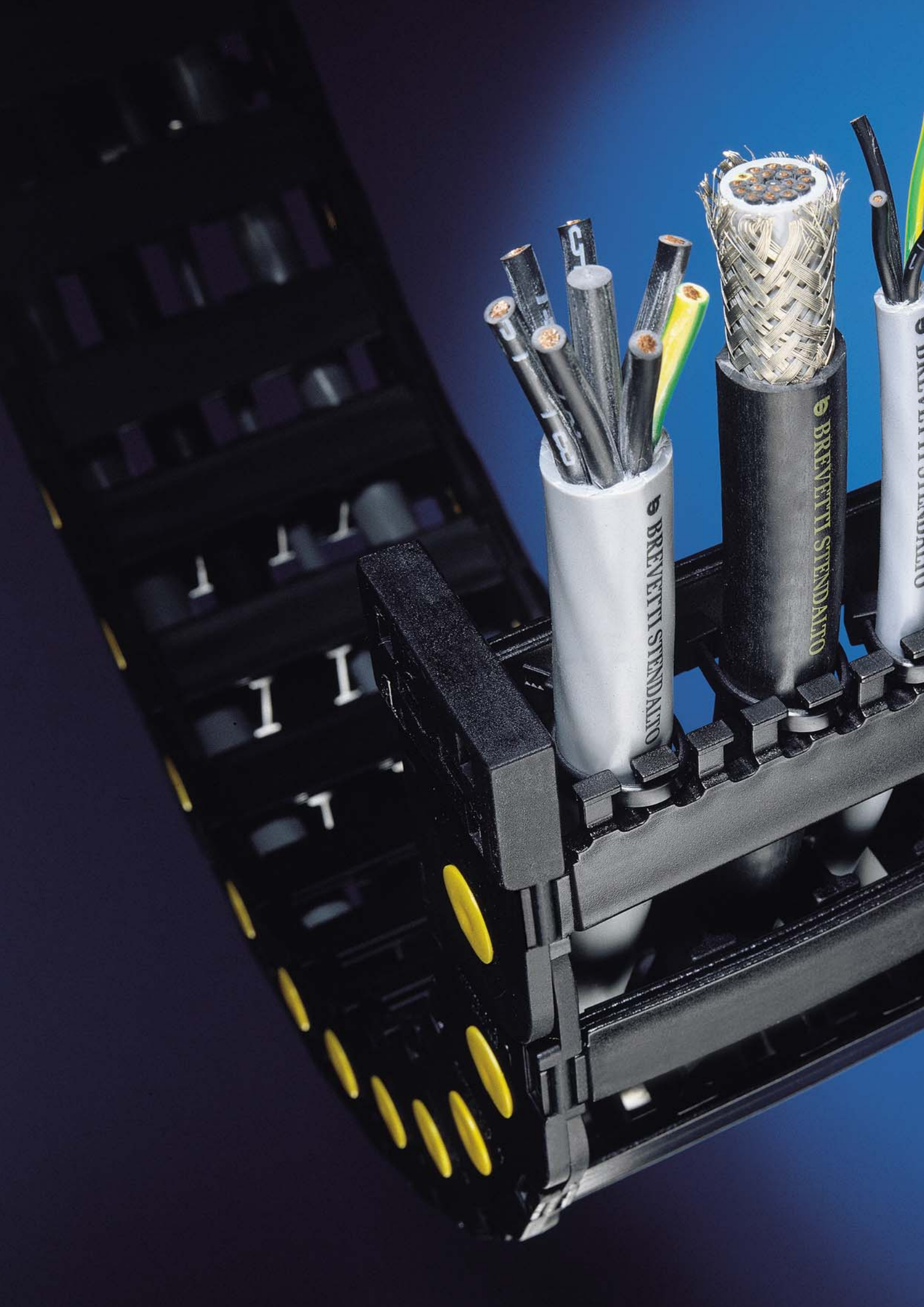

# Flexible Cables for Cable Chains

## Characteristics

Brevetti Stendalto, aware of the continuous development of the high technology production processes, offers a number of flexible and high flexible cables, constructed according to the most recent technologies. These high flexible cables enable a continuous operation for multi-shift-work under conditions of extreme bending stress<sup>(1)</sup>, for example industrial robots, machine tools and for the working of wood, automation systems etc.

The protection control according to the DIN VDE rules, gives a certificate showing the high standard of quality of the Brevetti Stendalto cables.

The wide choice of products composed of different types of cables, allows us to answer to the growing demand from all parts of the technical department.

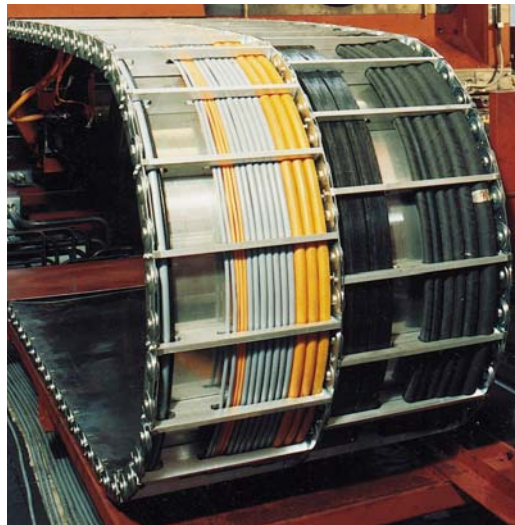

<sup>(1)</sup> The Brevetti Stendalto cables have been tested with accelerations exceeding  $20 \text{ m/s}^2$  and speed of 6 m/s.

# Flexible Cables

## Installation

For correct installation of cables in the cable chain, it is important to follow the guidelines listed below:

- 1- The cables have to be installed and unrolled from the drum carefully to avoid damage. It is therefore important to follow the indications in Fig.1. The coil should not be unrolled from the centre, but it should be placed on a support or on a turning plane and then be unrolled starting from the external ends.
- 2- Check the minimum allowed bending radius of the chosen cable and compare it with the bending radius of the chain. For a correct installation, the last mentioned should be larger compared to the bending radius of the cable.
- 3- There must be at least 10%-20% free space between the cable diameters and the internal dimensions of the chain. Install the cables/hoses symmetrically in the chain with the larger and heavier towards the outside and the smaller and lighter in the centre. Further, it is necessary to separate the cables using the separators, available for all the chains, or the split cross pieces with holes done in the appropriate sizes according to the external diameter of the cable.

(Fig. 2) It is important, when having high velocities and accelerations, to avoid the superimposing of the cables. Avoid contact between the different cables and hoses internally in the chain.

- 4- The cables/hoses must be placed and installed in such a way so that they can move freely side ways during the movement of the chain and also so that in the bending curve they do not cause any tension or traction on the cable chain.
- 5- The cables/hoses must be installed and fixed using the appropriate accessories (see pages 198/199), at the extremities of the movement of the chain (the mobile point). For chains that work in the self-supported state it is suggested that the fixed extremity of the chain (fixed point) should be fixed, however this shouldn't be done on applications with long travel distances, where the chain slides on itself in the guide channel.
- 6- Verify the installation of the cables in the chains with Brevetti Stendalto's technical office or request a personalised project by filling in the appropriate module (page 201).

Fig. 1

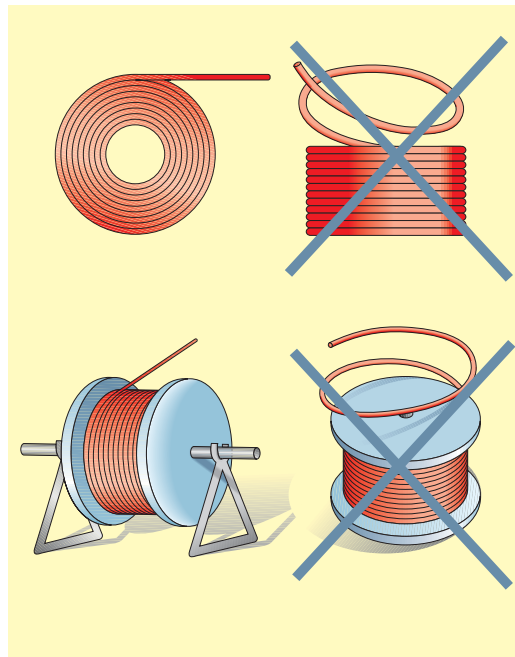
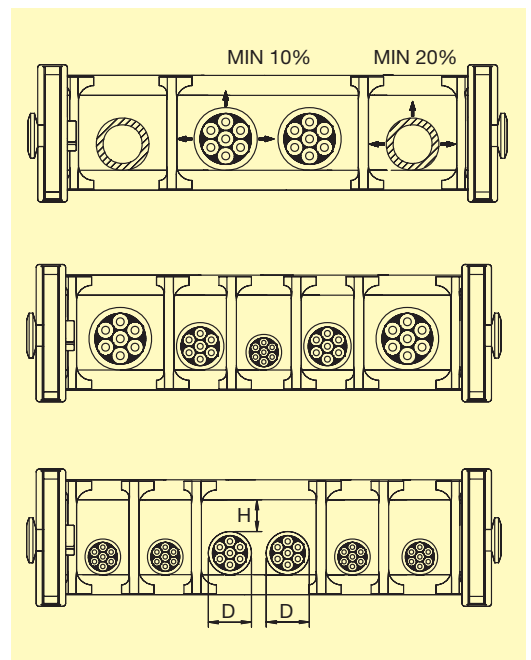
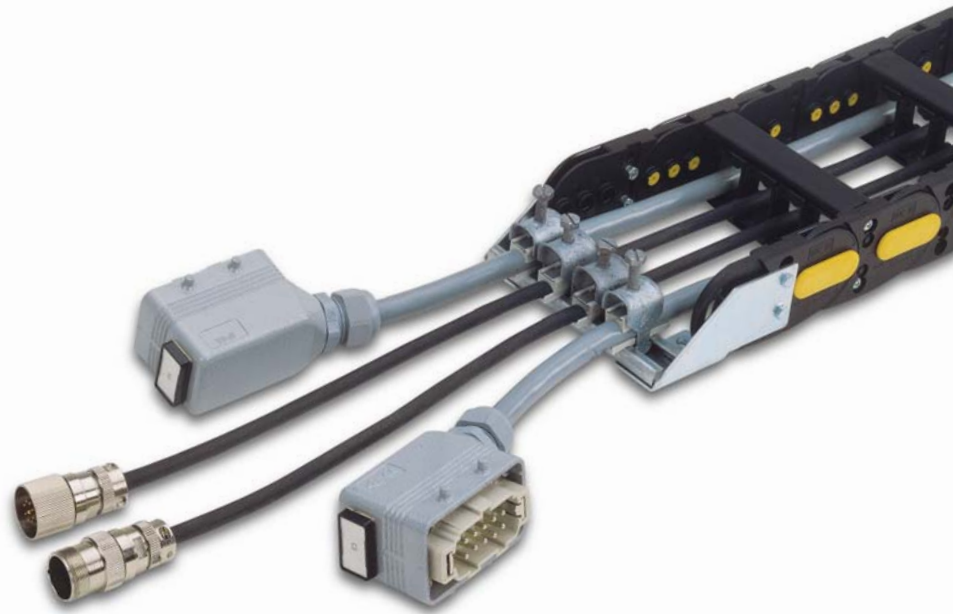

Fig. 2



## Ready to Install Chains with Electrical Cables

On request chain ready to be used with cables and plugs connected. Please contact our sales departments for further information.



## With Hydraulic Hoses

On request chain ready to be used with hydraulic hoses. Please contact our sales departments for further information.



## Custom-Built Packaging

For very large chains, example offshore applications, harbour cranes, steel mills, Brevetti Stendalto offers on request custom-built

packaging, for save transport and facilitated assembling on-site.

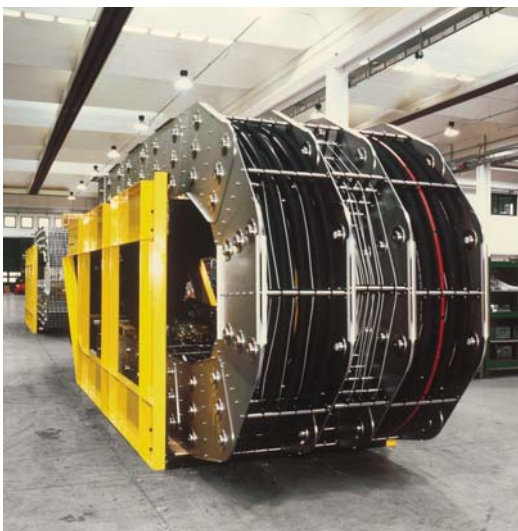

# Flexible Cables

## Tiewrap Clamp in Nylon

To allow easy fixing of the cables at the chain's end brackets, Brevetti Stendalto offers strong nylon tiewrap clamps.

The tiewrap is mounted on to a steel profile to assure a strong support.

This fixing system is available for our Heavy, Sliding and Protection series.

Order code:

Chain type: SR306SE168107

Tiewrap code for steel end brackets: SFC306SE168

Tiewrap code for nylon end brackets: SFCN306SE168



## Steel Cable Clamps

The steel cable clamps connect the cable to the extremities of the chain.

The plastic counter pressure cradle with the integrated screw tighten and fix the cable.

The smooth surface and the design of the cradles guarantee high stability and avoid any damage to the cables.

Special versions are available on request.

Fixing set is composed by the following parts:

- steel clamps with pressure cradle
- counter pressure cradle
- doublesided cradle for double and triple clamps
- steel mounting rails



Fig. A

C-profile rail

Part.no	Length mm
6000001	Standard 800 mm; available on request with different length

Single clamp in galvanised steel with 1 plastic pressure cradle and 1 counter pressure cradle

Part.no	Diameter mm	L	H
6000614C	06-14	18	62
6001418C	14-18	22	66
6001822C	18-22	26	70
6002226C	22-26	30	74
6002630C	26-30	34	78
6003034C	30-34	38	82
6003438C	34-38	42	86
6003842C	38-42	46	90

Double clamp in galvanised steel set complete with 1 plastic pressure cradle, 1 double sided cradle and 1 counter pressure cradle

Part.no	Diameter mm	L	H
6020614C	06-14	18	78
6021418C	14-18	22	86
6021822C	18-22	26	94
6022226C	22-26	30	103
6022630C	26-30	34	112
6023034C	30-34	38	120
6023438C	34-38	42	129
6023842C	38-42	46	138

Triple clamp in galvanised steel set complete with 1 plastic pressure cradle, 2 double sided cradles and 1 counter pressure cradle

Part.no	Diameter mm	L	H
6031012C	10-12	16	87
6031214C	12-14	18	93
6031416C	14-16	20	99
6031618C	16-18	22	105
6031820C	18-20	24	111
6032022C	20-22	26	117
6032224C	22-24	28	123
6032426C	24-26	30	129
6032628C	26-28	34	135
6032830C	28-30	38	141

Counter pressure cradle

Part.no	Diameter mm
6100612	06-12
6101214	12-14
6101618	16-18
6101822	18-22
6102226	22-26
6102630	26-30
6103034	30-34
6103438	34-38
6103842	38-42

Doublesided cradle

Part.no	Diameter mm
6201012	10-12
6201214	12-14
6201416	14-16
6201618	16-18
6202022	20-22
6202224	22-24
6202426	24-26
6202830	28-30
6203034	30-34
6203438	34-38
6203842	38-42

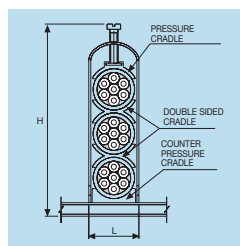
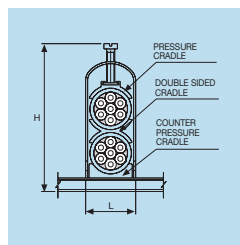
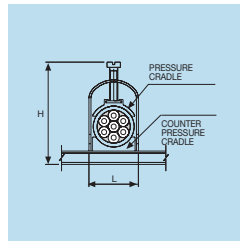
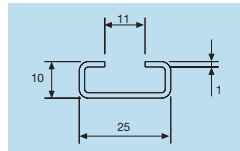





# Enquiry Form

Date	<b>Fax: +39 039 834250</b> <b>e-mail: tekno@brevettistendalto.it</b>
To:  <b>Brevetti Stendalto S.p.a.</b> <b>viale Stucchi 66/8</b> <b>20052 Monza (MI)</b>	Sender:

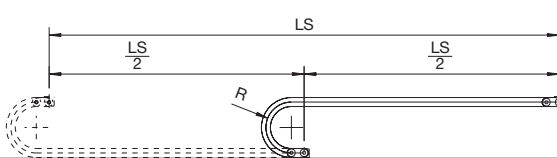
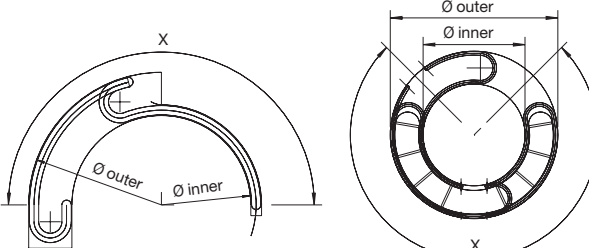
 <p> <input type="checkbox"/> Horizontal movement     <input type="checkbox"/> Vertical movement         </p> <p>           Travel distance (LS) _____ mm            Bending radius (R) _____ mm            Speed _____ m/s            Acceleration _____ m/s<sup>2</sup>            Travel frequency _____ Mov./h     _____ day/year            Environment _____                Humidity _____                Temperature _____                Installation in/outside _____                Clean/dirty _____         </p> <p>Remarks: _____</p> <p>_____</p> <p>_____</p> <p>_____</p> <p>Suggested chain _____</p> <p style="text-align: center;"><b>CABLES/HOSES</b></p> <table border="1" style="width:100%; border-collapse: collapse; text-align: center;"> <thead> <tr> <th>N°</th> <th>outer diameter</th> <th>weight per meter</th> <th>min. bending radius</th> </tr> </thead> <tbody> <tr><td> </td><td>mm</td><td>Kg/m</td><td>mm</td></tr> <tr><td> </td><td>mm</td><td>Kg/m</td><td>mm</td></tr> <tr><td> </td><td>mm</td><td>Kg/m</td><td>mm</td></tr> <tr><td> </td><td>mm</td><td>Kg/m</td><td>mm</td></tr> <tr><td> </td><td>mm</td><td>Kg/m</td><td>mm</td></tr> <tr><td> </td><td>mm</td><td>Kg/m</td><td>mm</td></tr> <tr><td> </td><td>mm</td><td>Kg/m</td><td>mm</td></tr> <tr><td> </td><td>mm</td><td>Kg/m</td><td>mm</td></tr> <tr><td> </td><td>mm</td><td>Kg/m</td><td>mm</td></tr> <tr><td> </td><td>mm</td><td>Kg/m</td><td>mm</td></tr> </tbody> </table> <p> <input type="checkbox"/> Request for quotation     <input type="checkbox"/> Request for technical drawing         </p>	N°	outer diameter	weight per meter	min. bending radius		mm	Kg/m	mm		mm	Kg/m	mm		mm	Kg/m	mm		mm	Kg/m	mm		mm	Kg/m	mm		mm	Kg/m	mm		mm	Kg/m	mm		mm	Kg/m	mm		mm	Kg/m	mm		mm	Kg/m	mm	 <p> <input type="checkbox"/> circular movement with 1 chain     <input type="checkbox"/> circular movement with 2 chains         </p> <p>           Rotation _____ degrees            Inner Ø _____ mm            Outer Ø _____ mm            Movable point     <input type="checkbox"/> Inner Ø     <input type="checkbox"/> Outer Ø            Movement with     <input type="checkbox"/> housing                                          <input type="checkbox"/> towing arm         </p> <p>           Speed _____ m/s            Acceleration _____ m/s<sup>2</sup>            Travel frequency _____ Mov./h     _____ day/year            Environment _____                Humidity _____                Temperature _____                Installation in/outside _____                Clean/dirty _____         </p> <p>Remarks _____</p> <p>_____</p> <p>_____</p> <p>Suggested chain _____</p> <p style="text-align: center;"><b>CABLES/HOSES</b></p> <table border="1" style="width:100%; border-collapse: collapse; text-align: center;"> <thead> <tr> <th>N°</th> <th>outer diameter</th> <th>weight per meter</th> <th>min. bending radius</th> </tr> </thead> <tbody> <tr><td> </td><td>mm</td><td>Kg/m</td><td>mm</td></tr> <tr><td> </td><td>mm</td><td>Kg/m</td><td>mm</td></tr> <tr><td> </td><td>mm</td><td>Kg/m</td><td>mm</td></tr> <tr><td> </td><td>mm</td><td>Kg/m</td><td>mm</td></tr> <tr><td> </td><td>mm</td><td>Kg/m</td><td>mm</td></tr> <tr><td> </td><td>mm</td><td>Kg/m</td><td>mm</td></tr> <tr><td> </td><td>mm</td><td>Kg/m</td><td>mm</td></tr> <tr><td> </td><td>mm</td><td>Kg/m</td><td>mm</td></tr> <tr><td> </td><td>mm</td><td>Kg/m</td><td>mm</td></tr> <tr><td> </td><td>mm</td><td>Kg/m</td><td>mm</td></tr> </tbody> </table>	N°	outer diameter	weight per meter	min. bending radius		mm	Kg/m	mm		mm	Kg/m	mm		mm	Kg/m	mm		mm	Kg/m	mm		mm	Kg/m	mm		mm	Kg/m	mm		mm	Kg/m	mm		mm	Kg/m	mm		mm	Kg/m	mm		mm	Kg/m	mm
N°	outer diameter	weight per meter	min. bending radius																																																																																						
	mm	Kg/m	mm																																																																																						
	mm	Kg/m	mm																																																																																						
	mm	Kg/m	mm																																																																																						
	mm	Kg/m	mm																																																																																						
	mm	Kg/m	mm																																																																																						
	mm	Kg/m	mm																																																																																						
	mm	Kg/m	mm																																																																																						
	mm	Kg/m	mm																																																																																						
	mm	Kg/m	mm																																																																																						
	mm	Kg/m	mm																																																																																						
N°	outer diameter	weight per meter	min. bending radius																																																																																						
	mm	Kg/m	mm																																																																																						
	mm	Kg/m	mm																																																																																						
	mm	Kg/m	mm																																																																																						
	mm	Kg/m	mm																																																																																						
	mm	Kg/m	mm																																																																																						
	mm	Kg/m	mm																																																																																						
	mm	Kg/m	mm																																																																																						
	mm	Kg/m	mm																																																																																						
	mm	Kg/m	mm																																																																																						
	mm	Kg/m	mm																																																																																						



# Overview of Products Range

		Inner width		Inner height		External width		External height		Pitch		Bending radius	
page		from mm	to mm	from mm	to mm	from mm	to mm	mm	mm	from mm	to mm		
<b>Serie Light</b> 	40	SR200	12	35	12	-	18	41	15	17	18	40	
	42	SR250	15	-	18	-	23	-	22	30	40	-	
	44	SR30090/91/92	18	38	18,5	-	29	49	23,5	30	33	100	
	46	SR325LI/LE	40	103	25	-	57	120	38	45	50	150	
	48	SR325A	40	103	25,5	-	57	120	37	45	50	150	
	50	SR325	40	103	25,5	-	55	118	37	45	50	150	
	52	SR339	40	76	39	-	60	96	50	35	50	100	
<b>Serie Medium</b> 	60	SR300A	15	75	18	-	27	87	23	30	40	120	
	62	SR300	14	36	18	-	30	52	23	30	40	120	
	64	SR305A	30	50	24	-	54	74	30	35	50	150	
	66	SR305	30	50	20	-	52	72	30	35	50	150	
	68	SR355A	45	95	31	-	74	124	43	40	75	200	
	70	SR355	45	95	30	-	74	124	45	40	75	200	
	72	SR400	40	60	25	-	62	82	35	40	50	150	
	74	SR435MI/ME	40	150	35	-	60	170	48	50	60	200	
	76	SR445MI/ME	50	362	45	-	72	384	64	67	75	300	
	78	SR660A	50	362	37	-	75	387	55	50	100	250	
	80	SR770A	45	357	60	-	80	392	78	70	150	300	
82	SR475MI/ME	74	374	75,5	-	110	410	100,5	105	150	400		
<b>Serie Heavy</b> 	88	SR306	43	355	30	37	79	391	55	65	75	300	
	94	SR307	42	354	40	47	80	392	64	70	75	250	
	100	SR308	38	350	48	57	82	394	75	80	150	400	
	106	SR309	64	400	70	75,5	120	456	100	100	200	500	
	110	SR310	200	600	112	-	260	660	150	145	200	750	
<b>Serie Protection</b> 	114	SR435PI/PE	40	150	35	-	60	170	48	50	75	200	
	116	SR445PI/PE	50	362	45	-	72	384	64	67	100	300	
	118	SR445AI/AE	50	362	45	-	72	384	64	67	100	300	
	120	SR475PI/PE	74	374	75,5	-	110	410	100,5	105	180	400	
	122	SR660	50	150	36	-	79	179	55	50	100	250	
	124	SR770	85	250	51	-	120	285	78	70	150	300	
	126	SR306CI/CE	43	355	37	-	79	391	55	65	107	300	
	128	SR308CI/CE	38	350	57	-	82	394	75	80	180	400	
	130	SR309C	200	400	72	-	256	456	100	100	200	500	
	132	SR309CI/CE	64	488	75,5	-	120	544	100	100	200	500	
<b>Serie Sliding</b> 	136	SR326	61	373	30	37	89	416	59	65	107	300	
	142	SR328	61	373	48	57	116	428	79	80	150	400	
	148	SR319	64	400	70	75,5	128	464	107	100	200	500	
	152	SR478MI/ME	74	498	75,5	-	112	536	106,5	105	150	400	
	154	SR478PI/PE	74	498	75,5	-	112	536	106,5	105	150	400	
	156	M60	115	539	60,5	-	165	589	90	90	150	400	
158	M80	115	539	80,5	-	195	619	117	110	200	700		
<b>Serie Robot</b> 	166	SR495	45	-	35	-	69	-	45	-	100	-	
	168	SR500	65	-	30	-	93	-	43	-	100	150	
	170	SR510TN	88	-	46	-	132	-	55-77	-	125	-	
	170	SR515TN	88	-	46	-	132	-	55-77	-	175	-	
	172	SR545	62	-	46	-	123	-	62	-	100	-	
	174	SR599	210	-	59	-	272	-	85	-	220	-	
<b>Serie Steel</b> 	180	BS2000	79	304	32	38	112	337	53	75	75	305	
	182	BS3000	106	306	52	58	142	342	74	95	150	535	
	184	BS3500	104	404	65	70	153	453	95	125	200	600	
	186	BS3500C	104	404	65	-	153	453	95	125	200	600	
	188	BS4000	150	500	112,5	115	216	566	145	180	250	1000	
	190	BS4500	300	600	182	180	390	690	220	250	400	1500	

•= standard; O=on request

Self supported length		Max. travel length	Snap open cover		Enclosed design	Vertical separator	Horizontal separator	Ver./horiz. separator	Drilled frame	Diameter	
max m	kg		int. radius	est. radius						int. mm	est. mm
0,90	0,1	-	-	-	-	-	-	-	-	-	-
1,30	0,1	-	-	-	-	-	-	-	-	-	-
1,45	0,1	o	-	-	-	-	-	-	-	-	-
1,90	0,5	o	•	•	-	o	-	-	-	-	-
1,90	0,5	o	-	•	-	o	-	-	-	-	-
1,75	0,5	o	-	-	-	o	-	-	-	-	-
2,20	1	o	-	-	-	o	-	-	-	-	-
1,70	0,1	-	•	-	-	-	-	-	-	-	-
1,55	0,1	o	-	-	-	-	-	-	-	-	-
1,40	1	-	•	-	-	o	-	-	-	-	-
1,90	1	o	-	-	-	o	-	-	-	-	-
2,30	1	-	•	-	-	o	-	-	-	-	-
2,30	1	o	-	-	-	o	-	-	-	-	-
1,60	1	-	•	-	-	o	-	-	-	-	-
2,20	1	o	•	•	-	o	-	-	-	-	-
3,70	1	o	•	•	-	o	o	o	-	-	-
2,45	1	o	•	-	-	o	o	o	-	-	-
3,80	1	o	•	-	-	o	o	o	-	-	-
4,75	1	o	•	•	-	o	o	o	-	-	-
3,10	1	-	•	•	o	o	o	o	o	-	-
3,90	1	-	•	•	o	o	o	o	o	-	-
4,95	1	-	•	•	o	o	o	o	o	-	-
6,50	1	-	•	•	o	o	o	o	o	-	-
7,00	1	-	•	•	o	o	o	o	o	-	-
2,10	1	-	•	•	•	o	o	o	-	-	-
3,35	1	-	•	•	•	o	o	o	-	-	-
3,35	1	-	•	•	•	o	o	o	-	-	-
4,45	1	-	•	•	•	o	o	o	-	-	-
2,30	1	-	•	-	•	o	o	o	-	-	-
3,45	1	-	•	-	•	o	o	o	-	-	-
2,70	1	-	•	•	•	o	o	o	-	-	-
4,00	1	-	•	•	•	o	o	o	-	-	-
5,80	1	-	-	•	•	o	o	o	-	-	-
6,00	1	-	•	•	•	o	o	o	-	-	-
-	-	•	•	•	o	o	o	o	o	-	-
-	-	•	•	•	o	o	o	o	o	-	-
-	-	•	•	•	-	o	o	o	o	-	-
-	-	•	•	•	-	o	o	o	-	-	-
-	-	•	•	•	-	o	o	o	-	-	-
-	-	•	•	•	-	o	o	o	-	-	-
-	-	-	•	-	-	-	-	-	-	600	755
-	-	-	•	-	-	o	-	-	-	630	830
-	-	-	•	-	-	•	-	-	-	940	1220
-	-	-	•	-	-	•	-	-	-	1060	1340
-	-	-	•	-	-	•	o	o	-	485	760
-	-	-	•	•	-	•	o	o	-	1400	2000
5,40	1	-	-	-	o	o	o	o	•	-	-
6,20	1	-	-	-	o	o	o	o	•	-	-
9,10	1	-	-	-	o	o	o	o	•	-	-
8,90	1	-	-	-	•	o	o	o	-	-	-
10,50	1	-	-	-	o	o	o	o	•	-	-
13,00	1	-	-	-	o	o	o	o	•	-	-

**7**

All rights reserved. No part of this publication may be reproduced, translated or transmitted in any form or by any means.  
All informations contained in this publication should be taken only as a guide for the use of Brevetti Stendalto products; no responsibility can be accepted for any error or omission. Brevetti Stendalto S.p.A. reserved the rights, without notice, to change design and construction of any products.  
Printed in June 2007