

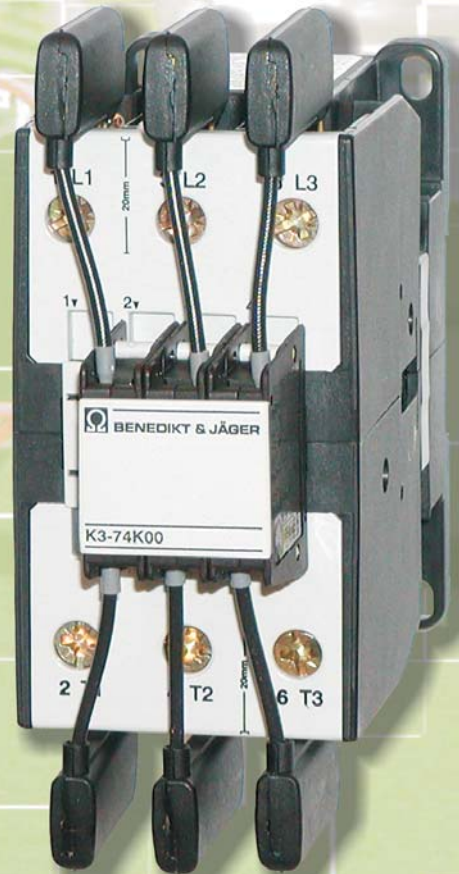







Contactors Motor-Starters

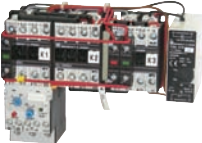

D677E121

Index		Page
	General	2
	Approvals	3
	Technical Information	5
	Mounting Information	6
	Mini Contactors	7
	Mini Contactors	8
	Interface Contactors	8
	Mini Reversing Contactors	14
	Technical Information	15
	Dimensions	20
	Contactor Relays	21
	Contactor Relays	22
	Technical Information	24
	Dimensions	26
	Contactors	27
	Contactors Overview	28
	Contactors, 3-pole	30
	Contactors, 4-pole	32
	Capacitor Switching Contactors	33
	Accessories	34
	Technical Information	43
Dimensions	64	
	Starters	73
	Star-Delta Starters	74
	Reversing Contactors	78
	Pole Changing Starters	80
	Technical Information	82
	Dimensions	89
	D.O.L. Starters	93
	D.O.L. Starters	94
	Enclosures	95
	Accessories	95
	Technical Information	96
	Dimensions	98
	Overload Relays	101
	Thermal Overload Relays	102
	Accessories	103
	Technical Information	106
	Dimensions	111
	Modular Contactors	115
	Contactors	116
	Accessories	117
	Technical Information	118
	Dimensions	122
	Representatives and Suppliers	122
	Alphabetical Index	125

Detailed Table of Contents may be found at beginning of each section

Technical data, dimension sketches, illustrations and weights given in our list and printed matter, are subject to change without notice.

General

Test Authorities, Registration Mark, Approvals

Low voltage switchgear from Benedict GmbH is built and tested to national and international specifications. All devices suit all important specifications without any test obligation, like VDE, BS and also relative to IEC Recommendations and to European Standards like IEC 947 and EN 60947.

It is for this reason of our Low voltage switchgear is used all over the world. In order to provide special versions, limitations to the max. voltages, currents and power ratings or special markings are sometimes necessary.

Quality Control System

Since November 1991 Benedict GmbH has been certified according to the quality control system **ÖNORM EN ISO 29001**. The target of the ISO-certification is, to grant the customer the quality of the performance of his supplier, who is audited in accordance with this standard.

CE-Marking



The manufacturer has to sign his products with the CE-Marking. With the CE-Marking the manufacturer confirms the accordance with the different EEC Directives. The CE-Marking is absolutely necessary to sell the products in the EEC.

Below you find the EEC Directives concerning our products.

Low Voltage Directive 2006/95/EC

EMC Directive 2004/108/EC

RoHS + WEEE 2002/95/EC + "002/96/EC

Country	North America	Switzerland	Russia	China
State deputy or private examination (state admitted)	UL Canada, USA	SEV	GOST	CCC
Label marking of examination boards	Listed Component			
Duty of approvals	all switchgear	all switchgear	all switchgear	all switchgear

Explanations for choice and supply of low voltage switchgear in Canada and USA

Marking of auxiliary contacts

At several devices in UL-data are two voltages for auxiliary contacts mentioned (e. g.: 600 volts at same potential, 150 volts at different potentials). That means, if the voltage is higher than 150 volts, the control voltage applied to input terminals must be at the same potential.

Low voltage switchgear for auxiliary circuits (e. g. contactor relays, control units, auxiliary contacts in general) usually approved for "Heavy Duty" or "Standard Duty" UL and besides these marked with the admissible max. voltage or with short codes (see table).

Marking of auxiliary contacts according to CSA and UL	Max. rated values per pole				Contact Rating Code Designation
	Voltage V	Current Make A	Break A	Cont. Current A	
Heavy Duty (HD or HVY DTY)	AC 120	60	6	10	A150
	AC 240	30	3	10	A300
	AC 480	15	1,5	10	A600
	AC 600	12	1,2	10	A600
	DC 125	2,2	2,2	10	N150
	DC 250	1,1	1,1	10	N300
	DC 600	0,4	0,4	10	N600
Standard Duty (SD or STD DTY)	AC 120	30	3	5	B150
	AC 240	15	1,5	5	B300
	AC 480	7,5	0,75	5	B600
	AC 600	6	0,6	5	B600
	DC 125	1,1	1,1	5	P150
	DC 250	0,55	0,55	5	P300
	DC 600	0,2	0,2	5	P600
-	AC 120	15	1,5	2,5	C150
	AC 240	7,5	0,75	2,5	C300
	AC 480	3,75	0,375	2,5	C600
	AC 600	3	0,3	2,5	C600
	DC 125	0,55	0,55	2,5	Q150
	DC 250	0,27	0,27	2,5	Q300
	DC 600	0,1	0,1	2,5	Q600
-	AC 120	3,6	0,6	1	D150
	AC 240	1,8	0,3	1	D300
	DC 125	0,22	0,22	1	R150
	DC 250	0,11	0,11	1	R300
-	AC 120	1,8	0,3	0,5	E150

Discernment at UL-Standards

Recognized Component Industrial Control Equipment

UL issues yellow "Guide cards" with Guide- and File-No.

Devices have permission to be marked with on the label

Devices as components approved for "factory wiring": devices for employment in control panels, when they are selected, mounted and wired according to the charging conditions by skilled worker.

Valid UL-Standards: UL 508 "Standard for Industrial Control Equipment" (partly limited)

Are devices approved as "Listed Equipment" the approval is also valid for using as "Recognized Component"

Listed Industrial Control Equipment

UL issues white "Guide cards" with Guide- and File-No.







Devices have to be marked with the "UL-Listing Mark"

Devices approved for "field wiring",

- a) devices for employment in control panels, when they are mounted and wired by skilled worker.
- b) devices for retail in USA

Valid UL-Standards: UL 508 "Standard for Industrial Control Equipment" (unlimited)

Approvals





Country	North America		Switzerland	Europe	Russia GOST	China	CENELEC CB-Certificates
Type	UL 		SEV 				
Mini Contactors, Reversing Contactors K1 and Accessories							
K1-07D..(=)	o	-	-	o	o	-	o
K1-07L..(=)	-	o	-	o	o	-	o
K1-07F..(=)	-	o	-	o	-	-	-
K1-09D..(=)	o	-	-	o	o	o	o
K1-09L..(=)	-	o	-	o	o	o	o
K1-09F..(=)	-	o	-	o	-	o	-
K1-12D..(=)	o	-	-	o	-	o	-
K1W09D01(=)	o	-	-	o	-	o	-
K1W12D01(=)	o	-	-	o	-	o	-
K1W09L01(=)	-	o	-	o	-	o	-
HK..., HKM..	o	-	-	o	-	-	o
RC-K1	o	-	-	o	-	-	-
Contactor Relays Series K3 and KG3							
K3-07A..(=)	o	-	-	o	-	-	-
K3-07D..(=)	o	-	-	o	-	-	-
KG3-07..	o	-	-	o	-	-	o
Contactors Series K3							
K3-10N..(=)	o	-	o	o	o	o	o
K3-14N..(=)	o	-	o	o	o	o	o
K3-18N..(=)	o	-	o	o	o	o	o
K3-22N..(=)	o	-	o	o	o	o	o
K3-24A..(=)	o	-	o	o	o	o	o
K3-32A..(=)	o	-	o	o	o	o	o
K3-40A..(=)	o	-	o	o	o	o	o
K3-50A..(=)	o	-	o	o	o	o	o
K3-62A..(=)	o	-	o	o	o	o	o
K3-74A..(=)	o	-	o	o	o	o	o
K3-90A..(=)	o	-	-	o	-	o	-
K3-115A..(=)	o	-	-	o	-	o	-
K3-151A..(=)	o	-	-	o	-	-	-
K3-176A..(=)	o	-	-	o	-	-	-
K3-210A..(=)	x	-	-	o	-	-	-
K3-260A..(=)	x	-	-	o	-	-	-
K3-316A..(=)	x	-	-	o	-	-	-
K3-450A..(=)	o	-	-	o	-	-	-
K3-550A..(=)	o	-	-	o	-	-	-
K3-700A..(=)	o	-	-	o	-	-	-
K3-860A..(=)	o	-	-	o	-	-	-
K3-1000A..(=)	-	-	-	o	-	-	-
K3-1200A..(=)	o	-	-	o	-	-	-
Contactors DC-operated Series KG3							
KG3-10.., -14..	o	-	-	o	-	-	o
KG3-18.., -22..	o	-	-	o	-	-	o
KG3-24.., -32..	o	-	-	o	-	-	o
KG3-40..	o	-	-	o	-	-	o
Capacitor Contactors Series K3							
K3-18NK..	o	-	-	o	o	o	o
K3-24K..	o	-	-	o	o	o	o
K3-32K..	o	-	-	o	o	o	o
K3-50K..	o	-	-	o	o	o	o
K3-62K..	o	-	-	o	o	o	o
K3-74K..	o	-	-	o	o	o	o
K3-90K..	o	-	-	o	-	o	-
K3-115K..	o	-	-	o	-	o	-
Aux. contacts							
HN.., HTN..	o	-	-	o	o	o	o
HA..	o	-	-	o	o	-	o
HB..	o	-	-	o	o	o	o
K2-DK, K2-SK	o	-	-	o	-	-	-
HKA.., HKT..	o	-	-	o	-	-	-
HKF22	-	-	-	o	-	-	-

o In standard version approved

x In test

- Not provided for test till now

Approvals

Country	North America		Switzerland	Europe	Russia GOST	China	CENELEC CB-Certificates
Type	UL 		SEV 				
Accessories							
K2-T..E, -A	-	-	-	o	-	-	-
K2-TP	o	-	-	o	-	-	-
K2-L	o	-	-	o	-	-	-
K2-IN.	o	-	-	o	-	-	-
K2-UN.	o	-	-	o	-	-	-
K2-IM	-	-	-	o	-	-	-
K2-E	o	-	-	o	-	-	-
VG-K2	-	-	-	o	-	-	-
RC-K3	o	-	-	o	-	-	-
Reversing Contactors , Serie KW3							
KW3-10	o	-	-	o	-	-	-
KW3-14	o	-	-	o	-	-	-
KW3-18	o	-	-	o	-	-	-
KW3-22	o	-	-	o	-	-	-
KW3-24	o	-	-	o	-	-	-
KW3-32	o	-	-	o	-	-	-
KW3-40	o	-	-	o	-	-	-
D.O.L. Starters							
P1..	o	-	-	o	-	-	-
Thermal Overload Relays							
U3/32	o	-	-	o	o	-	o
U3/42	o	-	-	o	o	-	o
U3/74	o	-	-	o	o	-	o
U12/16E	o	-	-	o	o	-	o
U12/16A	-	-	-	o	o	-	o
U12/16EM	-	-	-	o	o	-	o
U12/16EQ	-	-	-	o	o	-	o
U32	o	-	-	o	o	-	o
U60	o	-	-	o	o	-	o
U85	o	-	-	o	o	-	o
U180	x	-	-	o	-	-	-
U320	x	-	-	o	-	-	-
U840	-	-	-	o	-	-	-
U1250	-	-	-	o	-	-	-
Modular Contactors							
R20	o	-	o	o	o	-	o
R25	o	-	o	o	o	-	o
R40	o	-	o	o	o	-	o
R63	o	-	o	o	o	-	o
K1R	-	-	-	o	o	-	o
RH11	o	-	-	o	o	-	o

o In standard version approved



x In test

- Not provided for test till now

- and - Guide- and File-No.

These data are important for UL-inspecting engineers.

Devices

	Guide-No.				File-No.
					
	Kanada	USA	Kanada	USA	
Contactors	NLDX7	NLDX	NLDX8	NLDX2	E41502
Reversing Contactors	NLDX7	NLDX	-	-	E41502
Control Relays, Accessories	NKCR7	NKCR	NKCR8	NKCR2	E66273
Thermal Overload Relays	NKCR7	NKCR	-	-	E66273
Cam Switches	NLRV7	NLRV	-	-	
Circuit Breakers as Manual Motor Controller	NLRV7	NLRV	-	-	E129916
Circuit Breakers as Combination Motor Controller	NKJH7	NKJH	-	-	E197641
Bus Bar Assemblies	NLRV7	NLRV	-	-	E129916
Accessories	NKCR7	NKCR	-	-	E66273

Technical Information

Degree of protection acc. to IEC 60947-1

Protection ratings are prefixed by the internationally agreed letters IP followed by two digits.

1st digit: Pertains to solid objects
2nd digit: Pertains to water.

1 st digit	Short description	Definition
1	Protected against solid objects greater than 50 mm	Excludes solid objects exceeding 50 mm in diameter and protects against contact with live and moving parts by a large body surface such as a hand (but not against deliberate access).
2L	Protected against solid objects greater than 12,5 mm and against contact by standard test finger	Excludes solid objects exceeding 12,5 mm in diameter and protects against contact with live and moving parts by a standard test finger or similar objects not exceeding 80 mm in length.
3	Protected against solid objects greater than 2,5 mm	Excludes solid objects exceeding 2,5 mm in diameter or thickness.
4	Protected against solid objects greater than 1 mm	Excludes solid objects exceeding 1 mm in diameter or thickness.
5	Dust protected	Prevents ingress of dust in quantities and locations that would interfere with the intended operation of the equipment.
6	Dust tight	Prevents ingress of dust.

2 nd digit	Short description	Definition
1	Protected against dripping water	Dripping water (vertically falling drops) shall have no harmful effect.
2	Protected against dripping water when tilted up to 15°	Vertically dripping water shall have no harmful effect when the enclosure is tilted at any angle up to 15° from its normal position.
3	Protected against spraying water	Water falling as a spray at an angle up to 60° from the vertical shall have no harmful effect.
4	Protected against splashing water	Water splashed against the enclosure from any direction shall have no harmful effect.
5	Protected against water jets	Water protected by a nozzle against the enclosure from any direction shall have no harmful effect.
6	Protected against heavy seas	Water from heavy seas or water projected in powerful jets shall not enter the enclosure in harmful quantities.
7	Protected against the effects of immersion	Ingress of water in a harmful quantity shall not be possible when the enclosure is immersed in water under standard conditions of pressure and time.
8	Protected against submersion	No ingress of water.

Terminal markings acc. to EN50011

Auxiliary contacts of AC contactors and contacts of contactor relays and thermal overload relays are particularly marked. The terminal markings of normally-open contacts are printed as positive figures, they of normally-closed contacts as negative figures.

This gives a clear indication of the function of the contacts.

The figure below illustrates the determination of terminal markings for contactors with auxiliary contact blocks.

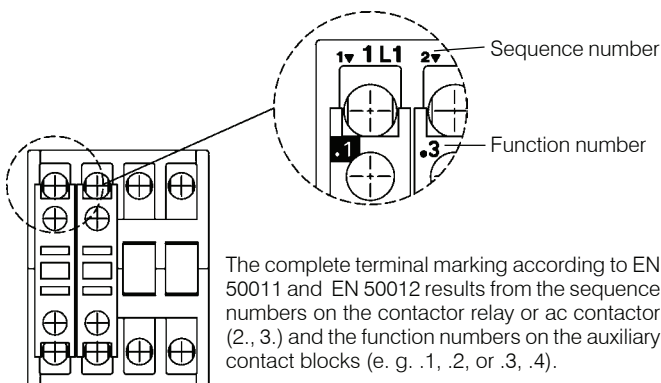

Resistance to climatic conditions acc. to IEC60068

Open-type devices are climate-resistant in the constant climate according to IEC60068-2-3 (this is a climate with an ambient temperature of 40°C and an atmospheric humidity of 90 to 95%).

Enclosed devices are climate-resistant in an alternating climate according to IEC 68-2-30 (this is a moist alternating climate with a 24-hour cycle between climates with an ambient temperature of 25°C, and an atmospheric humidity of 95 to 100% and an ambient temperature of 40°C, and an atmospheric humidity of 90 to 96% in the presence of condensation during rises in temperature).

Data are valid up to an altitude of 2000m above sea level.

Short circuit protection

Back up fuses should be used to protect contactors and starters against short circuits. For starters the device with the smaller admissible fuse at the main and at the control circuit (contactor or thermal overload) determines the fuse size.

After a short circuit devices have to be checked for correct operation. Disconnect power before proceeding with any work on the equipment!

Technical Information

Mounting positions of contactors

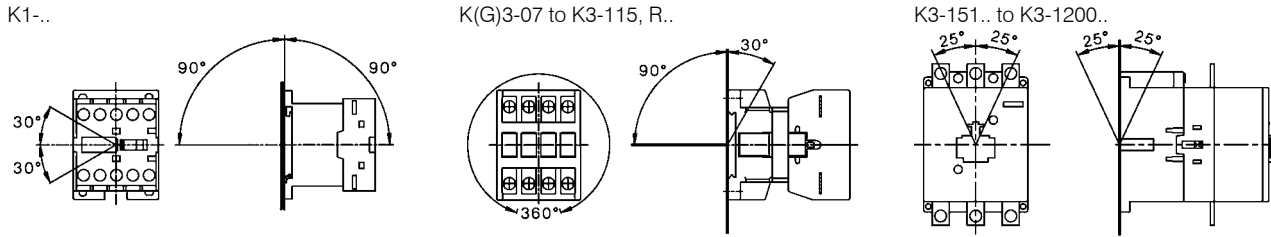

Terminal screws

Devices Type	Kind of connection				Screw driver	Tightening torque	
	Screw with washer	Screw with clamp box	Screw w. nut			Nm	lb. inch
Mini Contactors, all conductors							
K1..	M3,5	-	-	-	Pz2	0,8 - 1,4	7 - 12
Contactors Relays, all conductors							
K(G)3-07..	M3,5	-	-	-	Pz2	0,8 - 1,4	7 - 12
Contactors							
Main conductor							
K(G)3-10.. to K3-22..	M3,5	-	-	-	Pz2	0,8 - 1,4	7 - 12
K(G)3-24.. to K3-40..	-	M5	-	-	Pz2	2,5 - 3	22 - 26
K3-50.. to K3-74..	-	M6	-	-	Pz3	3,5 - 4,5	31 - 40
K3-90, K3-115	-	-	M8	-	4mm hex socket	4 - 6,5	35 - 57
K3-116.. to K3-176..	-	-	-	M8		17	150
K3-210.. to K3-316..	-	-	-	M10		35	315
K3-450.. to K3-700..	-	-	-	M12		60	540
K3-860..	-	-	-	M14		75	675
K3-1000.., K3-1200..	-	-	-	M12		60	540
Auxiliary conductor							
K(G)3-10 to K3-22	M3,5	-	-	-	Pz2	0,8 - 1,4	7 - 12
Coil conductor							
K(G)3-10 to K3-1200	M3,5	-	-	-	Pz2	0,8 - 1,4	7 - 12
Accessories							
HK, HKM	M3,5	-	-	-	Pz2	0,8 - 1,4	7 - 12
HA, HN, K2-..., HB..	M3,5	-	-	-	Pz2	0,8 - 1,4	7 - 12
Thermal Overload Relays							
Main conductor							
U12/16	M4	-	-	-	Pz2	1,2 - 1,8	11 - 16
U3/32	M3,5	-	-	-	Pz2	0,8 - 1,4	7 - 12
U3/42	M5	-	-	-	Pz2	2,5 - 3	22 - 26
U3/74	-	M6	-	-	Pz3	3,5 - 4,5	31 - 40
UAT21	-	M4	-	-	Size 3, 4	1,2 - 1,8	11 - 16
UAT22	-	M4	-	-	Size 3, 4	1,2 - 1,8	11 - 16
UAT23	-	M5	-	-	Size 3, 4, 5	2,5 - 3	22 - 26
Auxiliary conductor							
All devices	M3,5	-	-	-	Pz2	0,8 - 1,4	7 - 12
Contactors for Distribution Boards							
Conductors							
R20, R25	-	M3,5	-	-	Pz1	0,8 - 1,4	7 - 12
R40, R63	-	M5	-	-	Pz2	2,5 - 3	22 - 26
K1R	M3,5	-	-	-	Pz2	0,8 - 1,4	7 - 12
Coil conductor							
R20, R25	-	M3	-	-	Pz1	0,6 - 1,2	5 - 11
R40, R63	-	M3	-	-	Pz2	0,6 - 1,2	5 - 11
K1R	M3,5	-	-	-	Pz2	0,8 - 1,4	7 - 12



Mini Contactor Relays 4-pole
Auxiliary Contact Blocks

8

Interface Contactor Relays

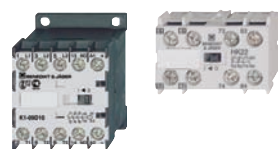

Mini Contactors
Auxiliary Contact Blocks

10



Mini Contactors With Fast On Tab Connectors

12



Mini Contactors With Solder Pins

12

Coil voltages

12



Mini Reversing Contactors
Auxiliary Contact Blocks

14



Technical Data

16



Dimensions

20

Mini Contactor Relays 4-pole

AC Operated

Ratings		Therm.	Contacts ²⁾		Distinc. Number	Additional Contact	Type	Coil voltage ¹⁾											
AC15	Rated Current I _{th} A	400V A	NO	NC	acc. to EN50011	Blocks Type	24	24V 50/60Hz	230	220-230V 50Hz	24VS	24V 50/60Hz w. protection ³⁾	230VS	220-230V 50Hz w. protection ³⁾	24VM	24V 50/60Hz 24V= DC	230VM	220-240V 50/60Hz 220V= DC	
230V A	400V A																		

4-pole, With Screw Terminals



3	2	10	4	-	40E	1 HK..	K1-07D40	...	10	0,16
3	2	10	3	1	31E	1 HK..	K1-07D31	...	10	0,16
3	2	10	2	2	22E	1 HK..	K1-07D22	...	10	0,16

Auxiliary Contact Blocks For Contactor Relays



Ratings		Thermal	Contacts ²⁾		Type	Pack pcs.	Weight kg/pc.
AC15	Rated Current A	Rated Current A	NO	NC			
230V A	400V A						
3	2	10	1	1	HK11	10	0,04
3	2	10	-	2	HK02	10	0,04
3	2	10	2	-	HK20	10	0,04
3	2	10	4	-	HK40	10	0,04
3	2	10	2	2	HK22	10	0,04
3	2	10	-	4	HK04	10	0,04

Aux. Contact Blocks

HK11

HK02

HK20

HK40

HK22

HK04

Wiring Diagrams

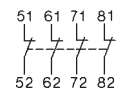
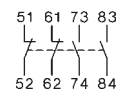
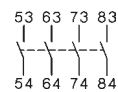

Distinc. Number according to EN50011 for Contactor Relay with Auxiliary Contact Block

K1-07D40	51E	42E	60E	80E	62E	44E
K1-07D31	42Y	33Y	51Y	71Y	53Y	35Y
K1-07D22	33Y	24Y	42Y	62Y	44Y	26Y

Preferable combinations with distinctive letter "E" according to DIN EN 50011

1) Other coil voltages see page 12
 2) Contacts suitable for electronic circuits, according to EN947-5-4 for rated voltage 24V DC (test ratings 17V DC, 5mA) Positively guided contacts
 3) with built-in coil suppressor (varistor)

DC Solenoid Operated

Type	Coil voltage ¹⁾		Contacts ²⁾		Distinc. Number acc. to EN50011	Additional Contact Blocks Type	Pack pcs.	Weight kg/pc.	Wiring Diagrams
	24	24VS	NO	NC					

24V= DC
24V= DC with protection ²⁾

4-pole, With Screw Terminals, Coil 2,5W



K1-07D40= ...	4	-	40E	1 HK..	10	0,19	
K1-07D31= ...	3	1	31E	1 HK..	10	0,19	
K1-07D22= ...	2	2	22E	1 HK..	10	0,19	

4-pole, With Screw Terminals, Coil 1,5W, 19 to 30V DC with suppressor ³⁾



K1-07D40= 24VR	4	-	-	-	10	0,20	
K1-07D31= 24VR	3	1	-	-	10	0,20	
K1-07D22= 24VR	2	2	-	-	10	0,20	

1) Other coil voltages on request

2) Contacts suitable for electronic circuits, according to EN947-5-4 for rated voltage 24V DC (test ratings 17V DC, 5mA) Positively guided contacts

3) with integrated coil suppressor (Transient Voltage Suppressor Diode)

Mini Contactors

AC Operated

Power Ratings		Rated Current	Aux. Contacts ²⁾		Type	Coil voltage ¹⁾	
AC2, AC3	AC1		Built-in	Additional			
380V						24	24V 50/60Hz
400V	660V					230	220-230V 50Hz
415V	690V	690V				24VS	24V 50/60Hz w. protection ³⁾
kW	kW	A				230VS	220-230V 50Hz w. protection ³⁾
						24VM	24V 50/60Hz 24V= DC
						230VM	220-240V 50/60Hz 220V= DC
							Pack Weight
							pcs. kg/pc.

3-pole, With Screw Terminals



Rated Current	Rated Voltage	Rated Power	Built-in	Additional	Type	Pack pcs.	Weight kg/pc.
4	4	20	1	-	1 HKM..	K1-09D10 ...	10 0,16
5,5	5,5	20	1	-	1 HKM..	K1-12D10 ...	10 0,16
4	4	20	-	1	1HK..	K1-09D01 ...	10 0,16
5,5	5,5	20	-	1	1HK..	K1-12D01 ...	10 0,16

4-pole, With Screw Terminals

Rated Current	Rated Voltage	Rated Power	Built-in	Additional	Type	Pack pcs.	Weight kg/pc.
4	4	20	-	-	1HK..	K1-09D00-40 ...	10 0,16
5,5	5,5	20	-	-	1HK..	K1-12D00-40 ...	10 0,16

Auxiliary Contact Blocks for Contactors K1-..

Rated Current	Rated Voltage	Thermal Rated Current	Contacts ²⁾		Type	Pack pcs.	Weight kg/pc.
A	A	A	NO	NC			
3	2	10	1	1	HKM11	10	0,04
3	2	10	-	2	HKM02	10	0,04
3	2	10	2	2	HKM22	10	0,04

Aux. Contact Blocks

HKM11

HKM02

HKM22

HK11

HK02

HK40

HK22

Wiring Diagrams

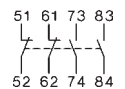
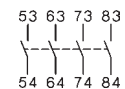
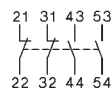

Contactors with Auxiliary Contact Block

Contacts according to EN50012

K1-..D10	21	12	32	-	-	-	-
----------	----	----	----	---	---	---	---

Contacts according to DIN EN50005

K1-..D01	-	-	-	12	03	41	23
K1-..D00-40	-	-	-	11	02	40	22

Prefer combinations according to EN50012

Suppressor Units for Contactors K1-..



Voltage Range V		Type	Pack pcs.	Weight kg/pc.
12 - 48V AC/DC	1600nF / 22 Ohm	RC-K1 24	10	0,01
48 - 127V AC/DC	680nF / 270 Ohm	RC-K1 110	10	0,01
110 - 250V AC/DC	220nF / 2200 Ohm	RC-K1 230	10	0,01

1) Other coil voltages see page 12

2) Contacts suitable for electronic circuits, according to EN947-5-4 for rated voltage 24V DC (test ratings 17V DC, 5mA) Positively guided contacts



3) with built-in coil suppressor (varistor)

DC Solenoid Operated

Type

Coil voltage ¹⁾
24 24V= DC
24VS 24V= DC with protection ³⁾



Aux. Contacts ²⁾
 Built in Additional
 in
 
 NO NC

Additional Overload Relay
 see page102
 Type

Pack pcs. Weight kg/pc.

Wiring Diagrams



3-pole, With Screw Terminals, Coil 2,5W

K1-09D10= . . .	1	-	1 HKM..	U12/16..K1	10	0,19
K1-12D10= . . .	1	-	1 HKM..	U12/16..K1	10	0,19

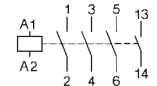

K1-09D01= . . .	-	1	1 HK..	U12/16..K1	10	0,19
K1-12D01= . . .	-	1	1 HK..	U12/16..K1	10	0,19

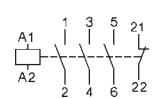

4-pole, With Screw Terminals, Coil 2,5W

K1-09D00-40= . . .	-	-	-	U12/16..K1	10	0,19
K1-12D00-40= . . .	-	-	-	U12/16..K1	10	0,19

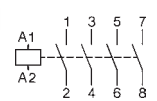

3-pole, With Screw Terminals, Coil 1,5W, 19 to 30V DC with suppressor ³⁾

K1-09D10=24VR	1	-	-	U12/16..K1	10	0,20
---------------	---	---	---	------------	----	------

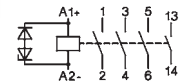

K1-09D01= 24VR	-	1	-	U12/16..K1	10	0,20
----------------	---	---	---	------------	----	------

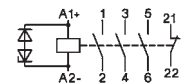

1) Other coil voltages on request

2) Contacts suitable for electronic circuits, according to EN947-5-4 for rated voltage 24V DC (test ratings 17V DC, 5mA) Positively guided contacts

3) with integrated coil suppressor (Transient Voltage Suppressor Diode)

Power Ratings		Rated Current	Aux. Contacts ²⁾		Type	Coil voltage ¹⁾	
			Built in	Additional			
AC2, AC3		AC1				24	24V 50/60Hz
380V						230	220-230V 50Hz
400V	660V					24VS	24V 50/60Hz w. protection ²⁾
415V	690V	690V				230VS	220-230V 50Hz w. protection ²⁾
kW	kW	A	NO	NC	Type	24VM	24V 50/60Hz 24V DC
						230VM	220-240V 50/60Hz 220V DC
						↓	Pack Weight pcs. kg/pc.

3-pole, with Fast On Tab Connectors 1 x 6,3mm or 2 x 2,8mm



4	4	16	1	-	1 HKM..	K1-09F10 ...	10	0,16
4	4	16	-	1	1 HK..	K1-09F01 ...	10	0,16

3-pole, with Solder Pins Ø1,15 for Printed Circuit Applications



4	4	16	1	-	-	K1-09L10 ...	10	0,16
4	4	16	-	1	-	K1-09L01 ...	10	0,16

4-pole, with Solder Pins Ø1,15 for Printed Circuit Applications

4	4	16	-	-	-	K1-09L00-40 ...	10	0,16
---	---	----	---	---	---	------------------------	----	------

Coil voltages for AC operated contactors

Suffix to contactor type e.g. K1-09D10 24	Voltage Marking at the coil		Rated Control Voltage U _s range			
	for 50Hz	for 60Hz	for 50Hz		for 60Hz	
	V	V	min. V	max. V	min. V	max. V
12	12	12	11	12	12	12
24	24	24	22	24	24	24
42	42	42	38,5	42	42	42
48	48	48	48	50	48	52
90	100	100	90	100	100	105
95	95-100	105-110	95	100	105	110
100	100	110-115	100	105	110	115
105	105-110	115-120	105	110	115	120
110	110-115	120-125	110	115	120	125
180	200	200	185	200	200	210

Suffix to contactor type e.g. K1-09D10 230	Voltage Marking at the coil		Rated Control Voltage U _s range			
	for 50Hz	for 60Hz	for 50Hz		for 60Hz	
	V	V	min. V	max. V	min. V	max. V
200	200	200-220	195	205	200	220
210	205-215	220-230	205	215	220	230
220	210-220	220-240	210	220	220	240
230	220-230	230-250	220	230	230	250
240	230-240		230	240	250	260
400	380-400	400-440	380	400	400	440
500	475-500	520-545	475	500	520	545
550	525-550	600	525	550	570	600

Standard voltages in bold type letters

Operating range of magnet-coils: 0,85 x U_s (min. value of rated control voltage) up to 1,1 x U_s (max. value of rated control voltage)

Coil not exchangeable

1) Other coil voltages see page 12

2) Contacts suitable for electronic circuits, according to EN947-5-4 for rated voltage 24V DC (test ratings 17V DC, 5mA) Positively guided contacts



3) with built-in coil suppressor (varistor)

DC Solenoid Operated

Type

Coil voltage ¹⁾
24 24V= DC
24VS 24V= DC with
 protection ³⁾



Aux. Contacts ²⁾
 Built in Additional
 in
 
 NO NC

Additional
 Overload
 Relay
 see
 page102
 Type

Pack Weight
 pcs. kg/pc.

Wiring Diagrams

3-pole, with Fast On Tab Connectors 1 x 6,3mm or 2 x 2,8mm



K1-09F10= . . . 1 - 1 HKM.. U12/16..K1 10 0,19

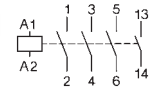

K1-09F01= . . . - 1 1 HK.. U12/16..K1 10 0,19

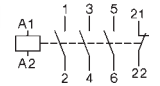

3-pole, with Solder Pins Ø1,15 for Printed Circuit Applications



K1-09L10= . . . 1 - - - 10 0,19

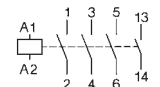

K1-09L01= . . . - 1 - - 10 0,19

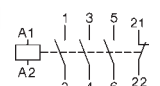

4-pole, with Solder Pins Ø1,15 for Printed Circuit Applications

K1-09L00-40= . . . - - - - 10 0,19

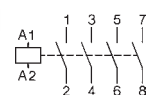



1) Other coil voltages on request

2) Contacts suitable for electronic circuits, according to EN947-5-4 for rated voltage 24V DC (test ratings 17V DC, 5mA) Positively guided contacts

3) with integrated coil suppressor (Transient Voltage Suppressor Diode)

Mini Reversing Contactors, Mechanical Interlocked

AC Operated

Power Ratings		Rated Current	Aux. Contacts ²⁾ Built-in	Additional on left hand side Contactor	Additional on right hand side Contactor	Type	Coil voltage ¹⁾	
AC2, AC3		AC1					24	24V 50/60Hz
380V							230	220-230V 50Hz
400V	660V						24VS	24V 50/60Hz w. protection ³⁾
415V	690V	690V			K1		230VS	220-230V 50Hz w. prot. ³⁾
kW	kW	A	NO	NC	Type		24VM	24V 50/60Hz 24V DC
							230VM	220-240V 50/60Hz 220V DC
							↓	Pack Weight pcs. kg/pc.

3-pole, with Screw Terminals

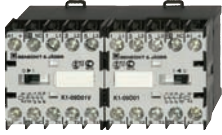

4	4	20	-	1	HKM11V	HKM11X	K1W09D01MC ...	1	0,32
5,5	5,5	20	-	1	HKM11V	HKM11X	K1W12D01MC ...	1	0,32
4	4	20	1	-	-	HKM..	K1W09D10MC ...	1	0,32
5,5	5,5	20	1	-	-	HKM..	K1W12D10MC ...	1	0,32

4-pole, with Screw Terminals



4	4	20	-	-	-	HKM..	K1W09D00-40MC ..	1	0,32
5,5	5,5	20	-	-	-	HKM..	K1W12D00-40MC ..	1	0,32

3-pole, with Solder Pins Ø1,15 for Printed Circuit Applications



4	4	16	-	1	-	-	K1W09L01MC ...	1	0,32
4	4	16	1	-	-	-	K1W09L10MC ...	1	0,32

Auxiliary Contact Blocks for Mini Reversing Contactors K1-..

Ratings		Thermal Rated Current	Contacts ²⁾		Type	Pack pcs.	Weight kg/pc.
AC15	400V	A					
230V			NO	NC			
A	A	A					
3	2	10	1	1	HKM11V	10	0,04
3	2	10	1	1	HKM11X	10	0,04



Aux. Contact Blocks

HKM11V

HKM11X

Wiring Diagrams



Reversing Starter Connector



For Reversing Starter Types, incl. Coil Connector

Type

Pack pcs. Weight kg/pc.

K1W09D..MC, K1W12D..MC

K1W-VB

1 0,01

1) Other coil voltages see page 12

2) Contacts suitable for electronic circuits, according to EN947-5-4 for rated voltage 24V DC (test ratings 17V DC, 5mA) Positively guided contacts

3) with built-in coil suppressor (varistor)

DC Solenoid Operated

Type

24
24VS
↓
Coil voltage ¹⁾
24V= DC
24V= DC with
protection ²⁾

Additional
Overload
Relay
see
page102
Type

Pack Weight
pcs. kg/pc.

Wiring Diagrams

3-pole, with Screw Terminals

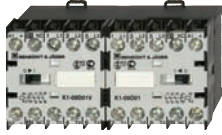

K1W09D01MC= . . .	U12/16..K1	1	0,32
K1W12D01MC= . . .	U12/16..K1	1	0,32
K1W09D10MC= . . .	U12/16..K1	1	0,32
K1W12D10MC= . . .	U12/16..K1	1	0,32

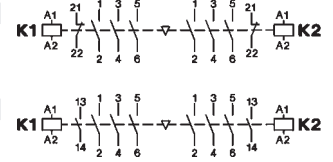

4-pole, with Screw Terminals

K1W09D00-40MC= . .	U12/16..K1	1	0,32
K1W12D00-40MC= . .	U12/16..K1	1	0,32

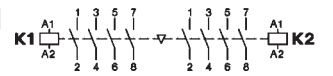

3-pole, with Solder Pins Ø1,15 for Printed Circuits Applications



K1W09L01MC= . . .	-	1	0,32
K1W09L10MC= . . .	-	1	0,32

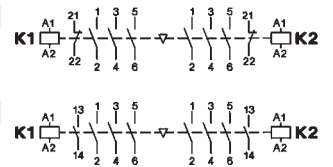

1) Other coil voltages on request

2) with integrated coil suppressor (Transient Voltage Suppressor Diode)

Mini Contactors

Data according to IEC 947-4-1, VDE 0660, EN 60947-4-1

Main Contacts	Type	K1-09D..	K1-09F..	K1-09L..	K1-12D..	
Rated insulation voltage U_i	V AC	690 ¹⁾	690 ¹⁾	690 ²⁾	690 ¹⁾	
Making capacity I_{eff}	at $U_e = 690V$ AC	A	165	165	165	
Breaking capacity I_{eff} $\cos\phi = 0,65$	400V AC	A	100	100	100	
	500V AC	A	90	90	90	
	690V AC	A	80	80	80	
Utilization category AC1 Switching of resistive load						
Rated operational current $I_e (=I_{th})$ at 40°C, open	A	20	16	16	20	
Rated operational power of three-phase resistive loads 50-60Hz, $\cos\phi = 1$	230V	kW	7,9	6	6	7,9
	240V	kW	8,3	6,5	6,5	8,3
	400V	kW	13,8	11	11	13,8
	415V	kW	14,3	11,5	11,5	14,3
Rated operational current $I_e (=I_{the})$ at 60°C, enclosed	A	16	12	12	16	
Rated operational power of three-phase resistive loads 50-60Hz, $\cos\phi = 1$	230V	kW	6,3	4,5	4,5	6,3
	240V	kW	6,7	5	5	6,7
	400V	kW	11	8	8	11
	415V	kW	11,5	8,5	8,5	11,5
Minimum cross-section of conductor at load with $I_e (=I_{th})$	mm ²	2,5	2,5	-	2,5	
Utilization category AC2 and AC3 Switching of three-phase motors						
Rated operational current I_e open and enclosed	220V	A	12	12	12	15
	230V	A	11,5	11,5	11,5	14,5
	240V	A	11	11	11	14
380-400V	A	9	9	9	12	
	415-440V	A	8	8	8	11
	500V	A	7	7	7	9
	660-690V	A	5	5	5	6,5
	Rated operational power of three-phase motors 50-60Hz	220-240V	kW	3	3	3
	380-440V	kW	4	4	4	5,5
	500-690V	kW	4	4	4	5,5
Utilization category AC4 Switching of squirrel cage motors, inching						
Rated operational current I_e open and enclosed	220V	A	12	12	12	15
	230V	A	11,5	11,5	11,5	14,5
	240V	A	11	11	11	14
380-400V	A	9	9	9	12	
	415-440V	A	8	8	8	11
	500V	A	7	7	7	9
	660-690V	A	5	5	5	6,5
	Rated operational power of three-phase motors 50-60Hz	220-240V	kW	3	3	3
380-440V		kW	4	4	4	5,5
500-690V		kW	4	4	4	5,5

1) Suitable at 690V for: earthed-neutral systems, overvoltage category I to IV, pollution degree 3 (standard-industry): $U_{imp} = 8kV$.
Data for other conditions on request.

2) Suitable at 690V for pollution degree 2, $U_{imp} = 6kV$.
Pollution degree 3 $U_i = 690V$ non-tracking of the printed circuit CTI ≥ 600
Pollution degree 3 $U_i = 500V$ non-tracking of the printed circuit CTI ≥ 400
Pollution degree 3 $U_i = 400V$ non-tracking of the printed circuit CTI ≥ 100

Mini Contactors

Data according to IEC 947-4-1, VDE 0660, EN 60947-4-1

Main Contacts			Type	K1-09D..	K1-09F..	K1-09L..	K1-12D..
Utilization category DC1							
Switching of resistive load	1 pole	24V	A	20	16	16	20
Time constant L/R ≤1ms		60V	A	20	16	16	20
Rated operational current I _e		110V	A	5	5	5	5
		220V	A	0,6	0,6	0,6	0,6
	3 poles in series	24V	A	20	20	20	20
		60V	A	20	20	20	20
		110V	A	20	20	20	20
		220V	A	16	16	16	16
Utilization category DC3 and DC5							
Switching of shunt motors and series motors	1 pole	24V	A	20	16	16	20
Time constant L/R ≤15ms		60V	A	5	5	5	5
Rated operational current I _e		110V	A	1	1	1	1
		220V	A	0,15	0,15	0,15	0,15
	3 poles in series	24V	A	20	16	16	20
		60V	A	20	16	16	20
		110V	A	20	16	16	20
		220V	A	2	2	2	2
Maximum ambient temperature							
Operation with thermal overload relay	open	°C		-40 to +60 (+90) ¹⁾			
	enclosed	°C		-40 to +40			
	open	°C		-25 to +60			
	enclosed	°C		-25 to +40			
Storage		°C		-50 to +90			
Short circuit protection for contactors without thermal overload relay							
Coordination-type "1" according to IEC 947-4-1 Contact welding without hazard of persons max. fuse size							
	gL (gG)	A		40	40	40	40
Coordination-type "2" according to IEC 947-4-1 Light contact welding accepted max. fuse size							
	gL (gG)	A		25	25	25	25
Contact welding not accepted max. fuse size							
	gL (gG)	A		10	10	10	10
For contactors with thermal overload relay the device with the smaller admissible backup fuse (contactor or thermal overload relay) determines the fuse size.							
Cable cross-sections for contactors without thermal overload relay							
main connector	solid or stranded	mm ²		0,5 - 2,5	Fast on	Solder connector	0,5 - 2,5
	flexible	mm ²		0,5 - 2,5	1x 6,3 x 0,8	Ø 1,15	0,5 - 2,5
Cables per clamp	flexible with multicore cable end	mm ²		0,5 - 1,5	or	-	0,5 - 1,5
		mm ²		2	2x 2,8 x 0,8	-	2
	solid or stranded	AWG		18 - 14			18 - 14
Frequency of operations z							
Contactors without thermal overload relay							
	without load	1/h		10000	10000	10000	10000
	AC3, I _e	1/h		600	600	600	700
	AC4, I _e	1/h		120	120	120	150
	DC3, I _e	1/h		600	600	600	700
Mechanical life	AC operated	S x 10 ⁶		5	5	5	5
	DC operated	S x 10 ⁶		15	15	15	15
Short time current							
	10s-current	A		96	96	96	120
Power loss per pole							
	at I _e /AC3 400V	W		0,15	0,15	0,15	0,25
Resistance to shock according to IEC 68-2-27							
Shock time 20ms sine-wave							
AC operated	NO	g		5	5	5	5
	NC	g		5	5	5	5
DC operated	NO	g		8	8	8	8
	NC	g		6	6	6	6

1) With reduced control voltage range 0,9 up to 1,0 x U_s and with reduced rated current I_e /AC1 according to I_e /AC3

Mini Contactors

Data according to IEC 947-5-1, VDE 0660, EN 60947-5-1

Auxiliary Contacts			Type	K1-07D.. K1-09D.. K1-12D..	K1-07D..= K1-09D..= K1-12D..=	K1-07D..= 24VR K1-09D..= 24VR	K1-09F..(=)	K1-07L..(=) K1-09L..(=)	HK..
Rated insulation voltage U_i			V AC	690 ¹⁾	690 ¹⁾	690 ¹⁾	690 ¹⁾	690 ²⁾	690 ¹⁾
Thermal rated current I_{th} to 690V									
Ambient temperature			40°C A	10	10	10	10	10	10
			60°C A	6	6	6	6	6	6
Power loss per pole			at I_{th} W	0,5	0,5	0,5	0,5	0,5	0,5
Utilization category AC15									
Rated operational current I_e			220-240V A	3	3	3	3	3	3
			380-415V A	2	2	2	2	2	2
			440V A	1,6	1,6	1,6	1,6	1,6	1,6
			500V A	1,2	1,2	1,2	1,2	1,2	1,2
			660-690V A	0,6	0,6	0,6	0,6	0,6	0,6
Utilization category DC13									
Rated operational current I_e			60V A	2	2	2	2	2	2
			110V A	0,4	0,4	0,4	0,4	0,4	0,4
			220V A	0,1	0,1	0,1	0,1	0,1	0,1
Maximum ambient temperature									
Operation			open °C	-40 to +60 (+90) ³⁾					
			enclosed °C	-40 to +40					
Storage			°C	-40 to +90					
Short circuit protection									
short-circuit current 1kA, contact welding not accepted max. fuse size			gL (gG) A	20	20	20	20	20	20
For contactors with thermal overload relay the device with the smaller admissible control fuse (contactor or thermal overload relay) determines the fuse size.									
Power consumption of coils									
AC operated			inrush VA	25	-	-	25	25	-
			sealed VA	4 - 5	-	-	4 - 5	4 - 5	-
			W	1,2	-	-	1,2	1,2	-
DC operated			inrush W	-	2,5	1,5	2,5	2,5	-
			sealed W	-	2,5	1,5	2,5	2,5	-
Operation range of coils									
in multiples of control voltage U_s				0,85 - 1,1	0,8 - 1,1	19 - 30V DC	0,85 - 1,1	0,85 - 1,1	-
Switching time at control voltage $U_s \pm 10\%$ ^{4) 5)}									
AC operated			make time ms	15 - 25	-	-	15 - 25	15 - 25	-
			release time ms	8 - 25	-	-	8 - 25	8 - 25	-
			arc duration ms	10 - 15	-	-	10 - 15	10 - 15	-
DC operated			make time ms	-	15 - 19	15 - 19	15 - 19	15 - 19	-
			release time ms	-	8 - 25	8 - 25	8 - 25	8 - 25	-
			arc duration ms	-	10 - 15	10 - 15	10 - 15	10 - 15	-
Cable cross-section									
all connectors			solid mm ²	0,5 - 2,5	0,5 - 2,5	0,5 - 2,5	Fast on	Solder connector	0,5 - 2,5
			flexible mm ²	0,5 - 2,5	0,5 - 2,5	0,5 - 2,5	1x 6,3 x 0,8	Ø 1,15	0,5 - 2,5
			flexible with multicore cable end mm ²	0,5 - 1,5	0,5 - 1,5	0,5 - 1,5	or		0,5 - 1,5
							2x 2,8 x 0,8		
Clamps per pole				2	2	2	-	-	2
			solid or stranded AWG	18 - 14	18 - 14	18 - 14			18 - 14

1) Suitable at 690V for: earthed-neutral systems, overvoltage category I to IV, pollution degree 3 (standard-industry): $U_{imp} = 8kV$.
Data for other conditions on request.

2) Suitable at 690V for pollution degree 2, $U_{imp} = 6kV$.
Pollution degree 3 $U_i = 690V$ non-tracking of the printed circuit CTI ≥ 600
Pollution degree 3 $U_i = 500V$ non-tracking of the printed circuit CTI ≥ 400
Pollution degree 3 $U_i = 400V$ non-tracking of the printed circuit CTI ≥ 100

3) With reduced control voltage range 0,9 up to 1,0 x U_s and with reduced thermal rated current I_{th} to I_e /AC15

4) Summary switching time = release time + arc duration

5) Release time of NC make time of NO increase when suppressor units for voltage peak protection are used (Varistor, RC-units, Diode units).

Mini Contactors for North America

Data according to UL508

Main Contacts (cULus)		Type	K1-09D.. K1W09D01	K1-09F..	K1-09L..	K1-07D..	K1-12D.. K1W12D01	HK..
Rated operational current "General Use"		A	15	15	20	10	20	10
Rated operational power of three-phase motors at 60Hz (3ph)	110-120V	hp	1½	1½	1½	-	2	-
	200-208V	hp	3	3	3	-	3	-
	220-240V	hp	3	3	3	-	3	-
	440-480V	hp	5	5	5	-	7½	-
	550-600V	hp	7½	7½	7½	-	10	-
Rated operational power of AC motors at 60Hz (1ph)	110-120V	hp	½	½	½	-	¾	-
	200-208V	hp	1	1	1	-	1½	-
	220-240V	hp	1½	1½	1½	-	2	-
Fuse / Short-circuit current		A/kA	30/5	30/5	30/5	-	30/5	-
Rated voltage		V AC	600	600	600 ¹⁾	600	600	600
Auxiliary Contacts (cULus)								
	heavy pilot duty	AC	A600	A600	A600	A600	A600	A600
	standard pilot duty	DC	Q600	Q600	Q600	Q600	Q600	Q600

1) Pollution degree	CTI - PWB	U _i
2	≥ 100	600V
3	≥ 400	480V
3	100 - 400	240V

Mini Contactors

Dimensions

AC and DC operated
with screw terminals

K1-07D..
K1-09D..
K1-12D..

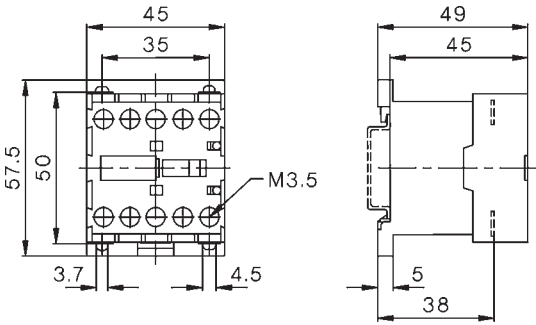

with fast on terminals

K1-07F..
K1-09F..

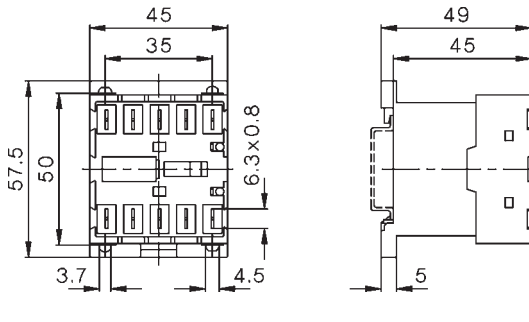

AC and DC operated
with solder connections

K1-07L..
K1-09L..

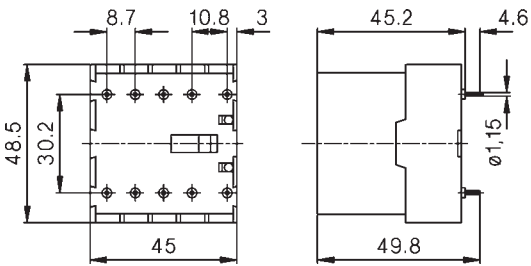

Auxiliary Contact Blocks

HK..

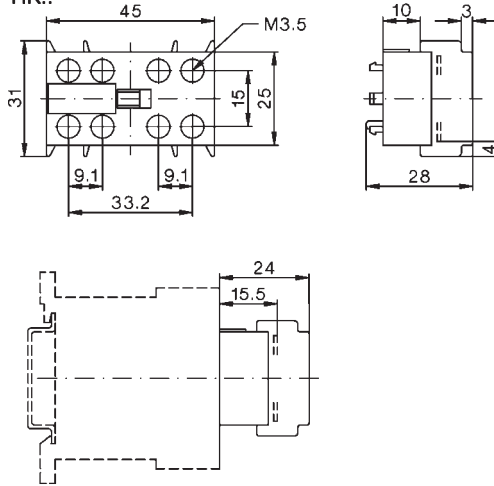

Reversing Contactors

K1W09D..MC
K1W12D..MC

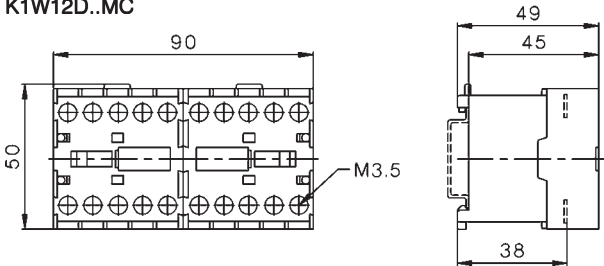

K1W09L..MC

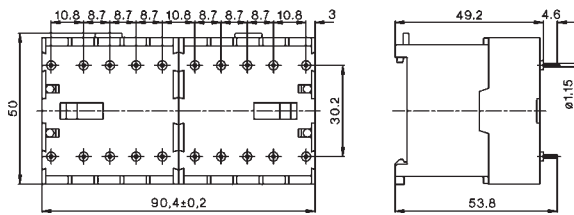

K1W09D..MC + U12/16E K1
K1W12D..MC + U12/16E K1

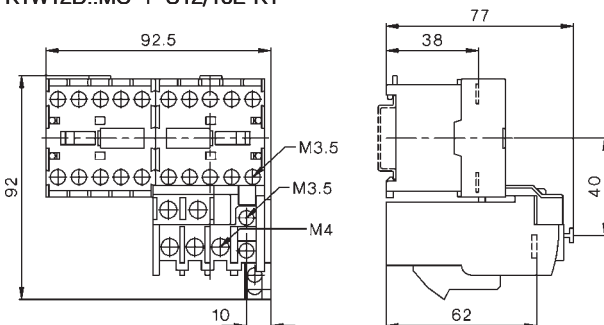



Contactor Relays 4-pole, AC Operated

22



Auxiliary Contact Blocks 1-pole

22



Contactor Relays 4-pole, DC Operated

23



Technical Data

24



Dimensions

26

Contactor Relays

AC Operated

Ratings	Therm. Rated Current	Built-in	Distinc. Number acc. to	Additional Contact Blocks	Type	Coil voltage ¹⁾	
						24	110
AC15	400V					24V 50/60Hz	
230V	A					110V 50Hz	110-120V 60Hz
A	A	I_{th} A	NO NC	EN50011	Type	220-240V 50Hz	230-264V 60Hz
						380-415V 50Hz	400-440V 60Hz
							Pack Weight
							pcs. kg/pc.

4-pole, contacts suitable for electronic circuits according to EN947-5-4²⁾

4	2	10	4	-	40E	max. 4	K3-07ND40	...	1	0,22
4	2	10	3	1	31E	HN..	K3-07ND31	...	1	0,22
4	2	10	2	2	22E		K3-07ND22	...	1	0,22
4	2	10	-	4	04E		K3-07ND04	...	1	0,22



Auxiliary Contact Blocks ³⁾

Ratings	Thermal	Contacts ²⁾	Type				Pack	Weight
AC15	Rated	Rated	NO	NC	EM	LB	pcs.	kg/pc.
230V	400V	Current						
A	A	A						

1-pole, contacts suitable for electronic circuits according to EN947-5-4²⁾

3	2	10	1	-	-	-	HN10	10	0,02
3	2	10	-	1	-	-	HN01	10	0,02
3	2	10	-	-	1	-	HN10U	10	0,02
3	2	10	-	-	-	1	HN01U	10	0,02



1-pole, for high switching capacity

6	3	25	1	-	-	-	HA10	10	0,03
6	3	25	-	1	-	-	HA01	10	0,03

Accessories see page 34 - 38

1) Other coil voltages see page 40

2) Contacts suitable for electronic circuits, according to EN947-5-4 for rated voltage 24V DC (test ratings 17V DC, 5mA) Positively guided contacts

3) Technical Data see page 62

DC Operated

Type	Coil voltage ¹⁾		Contacts		Distinc. Number acc. to	Additional Contact Blocks	Pack pcs.	Weight kg/pc.	Wiring Diagrams
	24	60	Built-in						
	24V DC	60V DC							
	110	110V DC							
	220	220V DC							
	↓		NO	NC	EN50011	Type			

3W Coil power, for high switching capacity ³⁾



KG3-07A40 . . .	4	-	40E	max. 4	1	0,53	A40, D40
KG3-07A31 . . .	3	1	31E	HN..	1	0,53	A1 13 23 33 43 A2 14 24 34 44
KG3-07A22 . . .	2	2	22E	oder	1	0,53	
KG3-07A04 . . .	-	4	04E	HA..	1	0,53	

3W Coil power, for electronic circuits ²⁾³⁾

KG3-07D40 . . .	4	-	40E	max. 4	1	0,53	A31, D31
KG3-07D31 . . .	3	1	31E	HN..	1	0,53	A1 13 21 33 43 A2 14 22 34 44
KG3-07D22 . . .	2	2	22E		1	0,53	A22, D22
KG3-07D04 . . .	-	4	04E		1	0,53	A1 13 21 31 43 A2 14 22 32 44

with double winding coil, for electronic circuits ²⁾³⁾



K3-07ND40= . . .	4	-	40E	max. 3	1	0,25	ND40=
K3-07ND31= . . .	3	1	31E	HN..	1	0,25	A1 (A3) (86) 13 23 33 43 A2 (85) 14 24 34 44
K3-07ND22= . . .	2	2	22E		1	0,25	
K3-07ND04= . . .	-	4	04E		1	0,25	

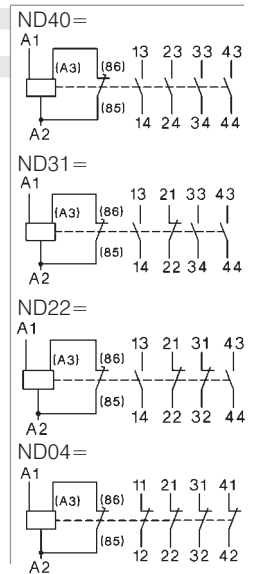
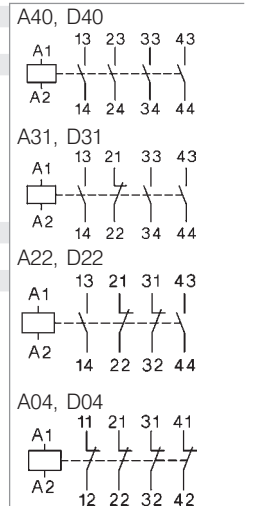

1) Other coil voltages on request

2) Contacts suitable for electronic circuits, according to EN947-5-4 for rated voltage 24V DC (test ratings 17V DC, 5mA) Positively guided contacts

3) with integrated coil suppressor (Transient Voltage Suppressor Diode)

Contactors Relays

Data according to IEC 947-5-1, VDE 0660, EN 60947-5-1

			K3-07ND	K3-07ND=	KG3-07A	KG3-07D
Rated insulation voltage U_i ¹⁾	V AC	Type	690	690	690	690
Thermal rated current I_{th} to 690V						
Ambient temperature	40°C	A	10	10	20	10
	60°C	A	6	6	16	6
Frequency of operations z	1/h		10000	10000	10000	10000
Mechanical life	$S \times 10^6$		10	10	10	50
Utilization category AC15						
Rated operational current I_e	220-240V	A	4	4	12	4
	380-415V	A	2	2	4	2
	440V	A	1,6	1,6	4	1,6
	500V	A	1,2	1,2	3	1,2
	660-690V	A	0,6	0,6	1	0,6
Utilization category DC13						
Rated operational current I_e	24-60V	A	3,5	3,5	8	3,5
per pole	110V	A	0,5	0,5	1	0,5
	220V	A	0,1	0,1	0,1	0,1
Power consumption of coils						
AC operated	inrush	VA	30 - 45	-	-	-
	sealed	VA	7 - 10	-	-	-
		W	2,6 - 3	-	-	-
DC operated	inrush	W	-	75	3	3
	sealed	W	-	2	3	3
Operation range of coils						
in multiples of control voltage U_s			0,85 - 1,1	0,8 - 1,1	0,8 - 1,1	0,8 - 1,1
Switching time at control voltage $U_s \pm 10\%$						
make time	ms		8 - 16	8 - 16	65 - 85	65 - 85
release time	ms		5 - 13	5 - 13	20 - 30 ³⁾	20 - 30 ³⁾
Maximum ambient temperature						
Operation	open	°C	-40 to +60 (+90) ²⁾			
	enclosed	°C	-40 to +40			
Storage		°C	-40 to +90			
Short circuit protection						
short-circuit current 1kA, contact welding not accepted						
max. fuse size	gL (gG)	A	20	20	25	20
Cable cross-section						
Connector	solid	mm ²	0,75 - 6			
	flexible	mm ²	1 - 4			
	flexible with multicore cable end	mm ²	0,75 - 4			
Magnet coil	solid	mm ²	0,75 - 2,5			
	flexible	mm ²	0,75 - 2,5			
	flexible with multicore cable end	mm ²	0,5 - 1,5			
Clamps per pole			2			
Connector	solid	AWG	18 - 10			
	flexible	AWG	18 - 10			
Clamps per pole			2			
Magnet coil	solid	AWG	14 - 12			
	flexible	AWG	18 - 12			
Clamps per pole			2			
Data according to UL508						
Rated operational current "General Use"	A		10	10	20	10
Rated operational voltage	max.	V AC	600	600	600	600
Auxiliary Contacts	heavy pilot duty		A600	A600	A600	A600

1) Suitable at 690V for: earthed-neutral systems, overvoltage category I to IV, pollution degree 3 (standard-industry): $U_{imp} = 8kV$.
Data for other conditions on request.

2) With reduced control voltage range 0,9 up to 1,0 x U_s and with reduced thermal rated current I_{th} according to I_e /AC15 3) with built-in coil suppressor

Contactor Relays

Position of Terminals

AC operated

DC operated with double wound coil

K3-07ND22

K3-07ND31

K3-07ND40

K3-07ND04

K3-07ND22=

K3-07ND31=

K3-07ND40=

K3-07ND04=

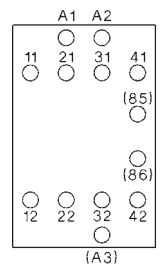
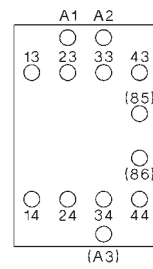
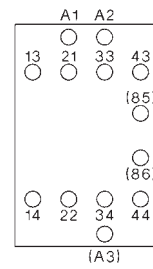
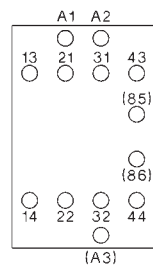
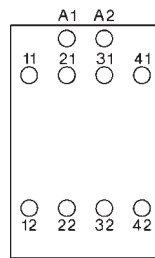
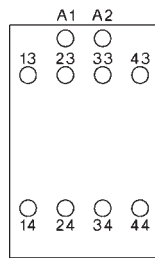
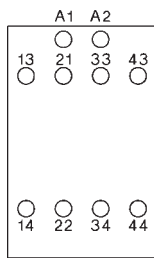
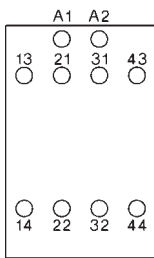

DC solenoid operated

KG3-07A22
KG3-07D22

KG3-07A31
KG3-07D31

KG3-07A40
KG3-07D40

KG3-07A04
KG3-07D04

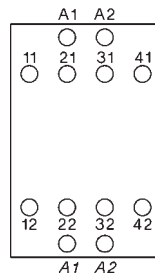
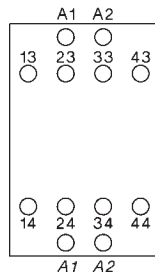
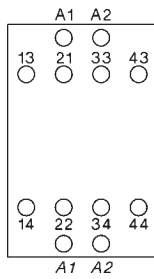
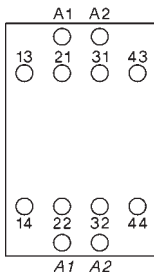

Contactors Relays

Dimensions

AC operated

K3-07ND..

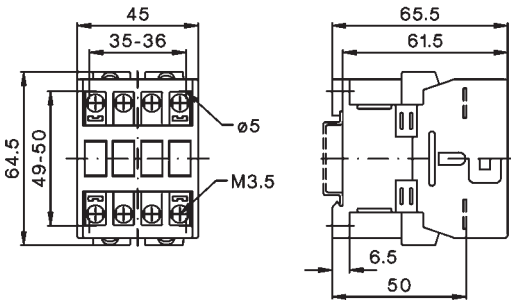

DC solenoid operated

KG3-07..

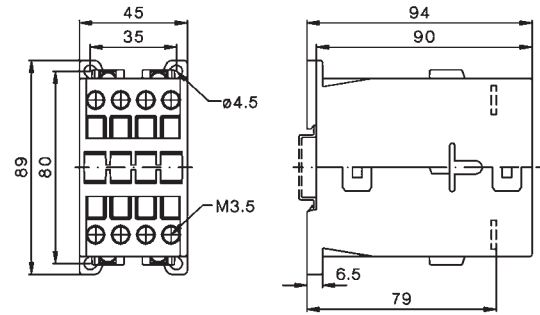

DC operated with double winding coil

K3-07ND.. =

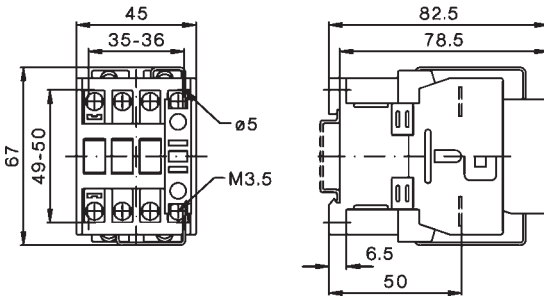





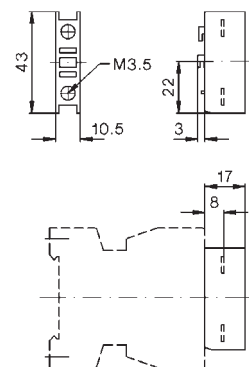



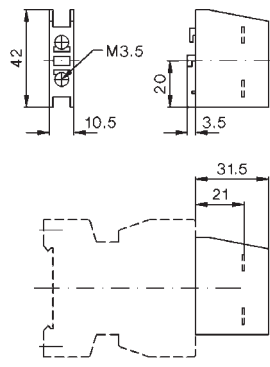







Auxiliary contact blocks

HN10, HN01

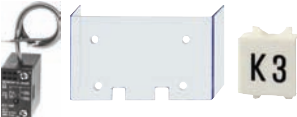

HA10, HA01



	Contactor overview	28
	Contactors 3-pole, AC Operated	30
	Contactors 3-pole, DC Operated	31
	Contactors 4-pole	32
	Capacitor Switching Contactors	33
	Auxiliary Contact Blocks Snap-on Momentary Contacts Additional Fourth Poles for Contactors	34
	Pneumatic Timers Electronic Timers On-delay Electronic Timers Off-delay	35
	Mechanical Interlocks Latches Additional Terminals, Parallel Connectors	36
	Indicator Units Fuse Holders Suppressor Units	37
	Interface Terminal Covers Mounting Parts, Marking System	38
	Control Voltages	40
	Spare Coils AC-operated Feeder Groups	40
	Spare Coils DC-operated Spare Contacts	41
	Technical Data	44
	Dimensions	64







Contactors 3-pole

- Up to 1200A AC3
- Up to 1350A AC1
- DIN-rail mounting up to AC3 115A
- International Approvals
- Data according to IEC 947 / EN 60947













Ratings		10A	14A	18A	22A	24A	32A	40A	50A	62A	74A	90A	115A
AC3 400V	Motor	10A	14A	18A	22A	24A	32A	40A	50A	62A	74A	90A	115A
	380-400V 660-690V	4kW 5,5kW	5,5kW 7,5kW	7,5kW 10kW	11kW 10kW	11kW 15kW	15kW 18,5kW	18,5kW 18,5kW	22kW 30kW	30kW 37kW	37kW 45kW	45kW 55kW	55kW 55kW
AC1 690V at 40°C		25A	25A	32A	32A	50A	65A	80A	110A	120A	130A	160A	200A
Type	K3-	10ND10	14ND10	18ND10	22ND10	24A00	32A00	40A00	50A00	62A00	74A00	90A00	115A00
Auxiliary contacts		1NO	1NO	1NO	1NO	-	-	-	-	-	-	-	-
Type	K3-	10ND01	14ND01	18ND01	22ND01								
Auxiliary contacts		1NC	1NC	1NC	1NC								
Cable cross-section													
Solid	mm ²		0,75 - 6				1,5 - 25			4 - 50		10 - 120	
Flexible	mm ²		1 - 4				2,5 - 16			10 - 35		10 - 95	
Auxiliary contact													
I _{th} 40°C	A		16				-			-		-	
AC15 230V	A		12				-			-		-	
400V	A		4				-			-		-	
Power consumption of coils	Inrush VA hold VA Operation range of coils		33 - 45 7 - 10 0,85 - 1,1				90 - 115 9 - 13 0,85 - 1,1			140 - 165 13 - 18 0,85 - 1,1		280 5 0,85 - 1,1	
Mounting		35mm DIN-rail or base										2x DIN-rail or base	
Additional aux. contact blocks	Front mounting Type	HN10 1NO f. low level switching	HN01 1NC f. low level switching	HA10 1NO 25A I _{th}	HA01 1NC 25A I _{th}	max. 4 HN.. or 4 HA..						max. 7 HN.. or 7 HA..	
Additional aux. contact blocks	Side mounting Type	-	-	-	-	HB11 1NO+1NC f. low level switching	HB02 2NC f. low level switching	max. 2 HB..					
Overload Relay (thermal)	Single phase protection Temperature compensation Trip and alarm contacts												
Type		U3/32					U3/74					U85	
		U12/16..K3		U3/42									
Number of Setting Ranges from		16 0,12 - 30A	16 0,12 - 32A	4 10 - 42A	5 20 - 74A					2 60 - 120A			
Busbar sets		-	-	-	-					-			



150A	175A	210A	260A	315A	450A	550A	700A	860A	1000A	1200A
75kW 90kW	90kW 110kW	110kW 160kW	132kW 210kW	160kW 250kW	250kW 375kW	300kW 475kW	400kW 630kW	500kW 700kW	580kW 850kW	680kW 1000kW
230A	250A	350A	450A	500A	600A	760A	1000A	1100A	1200A	1350A
151A00	176A00	210A00	260A00	316A00	450A22	550A22	700A22	860A22	1000A12	1200A12
-	-	-	-	-	2NO+2NC	2NO+2NC	2NO+2NC	2NO+2NC	1NO+2NC	1NO+2NC
2 x 16-120 2 x 16-120	busbar 30x6	busbar 30x6	busbar 30x6	busbar 30x6	busbar 30x5	busbar 40x6	busbar 50x8	busbar 50x8	busbar 50x10	busbar 50x10
-	-	-	-	-	-	10	3	2	10	3
350 5 0,85 - 1,1	350 5	360 5	360 5 0,85 - 1,1	360 5	800-950 9-11	800-950 9-11	1350-1600 21-25 0,85 - 1,1	1350-1600 21-25	2400 70 0,85-1,1	2400 70
base										
	HKT11 1NO+1NC	HKT22 2NO+2NC	max. 1 pc.							
	HKF22 2NO+2NC	max. 1 pc.								
	HKB11 1NO+1NC	max. 2 pcs.								
	HKA11 1NO+1NC	max. 2 pcs.								
	U180		U320		U800					
1 120 - 180A integrated		2 144 - 320A integrated		3 240 - 800A						
				SU840/550	SU840/860					

Contactors 3-pole

AC Operated







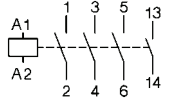
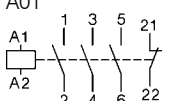

Ratings		Rated Current	Aux. Contacts		Type	Coil voltage ¹⁾	Pack pcs.	Weight kg/pc.
AC2, AC3			Built-in	Additional see page 34				
380V								
400V	660V	AC1				24		
415V	690V	690V				110		
kW	kW	A	NO	NC	Typ	230		
						400		
						▼		
								
4	5,5	25	1	-	max. 4	K3-10ND10 ...	1	0,23
4	5,5	25	-	1	HN.. or HA..	K3-10ND01 ...	1	0,23
5,5	7,5	25	1	-		K3-14ND10 ...	1	0,23
5,5	7,5	25	-	1		K3-14ND01 ...	1	0,23
7,5	10	32	1	-		K3-18ND10 ...	1	0,23
7,5	10	32	-	1		K3-18ND01 ...	1	0,23
11	10	32	1	-		K3-22ND10 ...	1	0,23
11	10	32	-	1		K3-22ND01 ...	1	0,23
								
11	15	50	-	-	max. 4	K3-24A00 ...	1	0,48
15	18,5	65	-	-	HN.. or HA..	K3-32A00 ...	1	0,48
18,5	18,5	80	-	-	and 2HB..	K3-40A00 ...	1	0,48
								
22	30	110	-	-	max. 4 (3) ²⁾	K3-50A00 ...	1	0,85
30	37	120	-	-	HN.. or HA..	K3-62A00 ...	1	0,85
37	45	130	-	-	and 2HB..	K3-74A00 ...	1	0,85
								
45	55	160	-	-	max. 7	K3-90A00 ... ³⁾	1	2,2
55	55	200	-	-	HN.. or HA.. and 2HB..	K3-115A00 ... ³⁾	1	2,2
								
75	110	230	-	-	1 HKT..	K3-151A00 ... ³⁾	1	4
90	132	250	-	-	and 2 HKA11	K3-176A00 ... ³⁾	1	4
								
110	160	350	-	-		K3-210A00 ... ³⁾	1	7,2
132	210	450	-	-		K3-260A00 ... ³⁾	1	7,2
160	250	500	-	-		K3-316A00 ... ³⁾	1	7,2
								
250	375	600	2	2	1 HKF22	K3-450A22 ...	1	13
300	475	760	2	2		K3-550A22 ...	1	13,5
								
400	630	1000	2	2		K3-700A22 ...	1	26,5
500	700	1100	2	2		K3-860A22 ...	1	27,6
								
580	850	1200	1	2	2 HKB11	K3-1000A12 ...	1	49
680	1000	1350	1	2		K3-1200A12 ...	1	53

1) Coil voltage range and other coil voltages see page 39

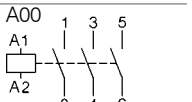
2) max. 3 HN.. or HA.. for DC-operated Contactors

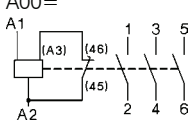
3) with integrated coil suppressor

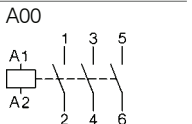
DC Operated

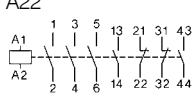
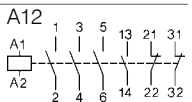
Type	Coil voltage ¹⁾	Coil power	Additional Overload Relay see page 102	Type	Pack pcs.	Weight kg/pc.	Wiring Diagram
	24 24V DC						
	48 48V DC	inrush/hold					
	110 110V DC	W/W					
	KG3-10A10 ... ³⁾	3/3	U3/32	1	0,53	A10	
	KG3-10A01 ... ³⁾	3/3	U12/16E U12/16EQ	1	0,53		
	KG3-14A10 ... ³⁾	3/3	UAT21	1	0,53		
	KG3-14A01 ... ³⁾	3/3		1	0,53		
	KG3-18A10 ... ³⁾	3/3		1	0,53	A01	
	KG3-18A01 ... ³⁾	3/3		1	0,53		
	KG3-22A10 ... ³⁾	3/3		1	0,53		
	KG3-22A01 ... ³⁾	3/3		1	0,53		
	KG3-24A00 ... ³⁾	4/4	U3/32	1	0,57	A00	
	KG3-32A00 ... ³⁾	4/4	U3/42	1	0,57		
	KG3-40A00 ... ³⁾	4/4	UAT..	1	0,57		
	K3-50A00= ...	200/6	U3/74	1	0,9	A00=	
	K3-62A00= ...	200/6		1	0,9		
	K3-74A00= ...	200/6		1	0,9		
	K3-90A00 ... ²⁾³⁾	280/5	U85	1	2,2	A00	
	K3-115A00 ... ²⁾³⁾	280/5		1	2,3		
	K3-151A00 ... ²⁾³⁾	350/5	U180	1	4		
	K3-176A00 ... ²⁾³⁾	350/5		1	4		
	K3-210A00 ... ²⁾³⁾	360/5	U320	1	7,2		
	K3-260A00 ... ²⁾³⁾	360/5		1	7,2		
	K3-316A00 ... ²⁾³⁾	360/5		1	7,2		
	K3-450A22 ... ²⁾	800/10	U800	1	13	A22	
	K3-550A22 ... ²⁾	800/10	+SU840/550	1	13,5		
	K3-700A22 ... ²⁾	1500/20	U800	1	26,5		
	K3-860A22 ... ²⁾	1500/20	+SU840/860	1	27,6		
	K3-1000A12= ...	2100/60		1	49	A12	
	K3-1200A12= ...	2100/60		1	53		

1) Other coil voltages on request

2) Contactors K3-90A00 ... to K3-860A22 ... are AC and DC operated

K3-90A00 **230** to K3-860A22 **230** can be used at **220VDC** and 220-240V 50/60Hz

3) with integrated coil suppressor

Contactors 3-pole

DC Operated



Ratings		Rated Current	Aux. Contacts		Type	Coil voltage ¹⁾		Pack Weight pcs. kg/pc.	Wiring Diagram
AC2	AC3		Built-in	Additional		24	60		
380V		AC1		see page 34		24V= DC			
400V	660V	690V	NO NC	Type		60V= DC			
415V	690V					110V= DC		220V= DC	
kW	kW	A							
4	5,5	25	1	-	max. 3				
4	5,5	25	-	1	HN..				
					or				
					HA..				
5,5	7,5	25	1	-					
5,5	7,5	25	-	1					
7,5	10	32	1	-					
7,5	10	32	-	1					
11	10	32	1	-					
11	10	32	-	1					
11	15	50	-	-	max. 4				
15	18,5	65	-	-	HN.. or				
18,5	18,5	80	-	-	HA..				
					+ 2HB..				

Type	Coil voltage ¹⁾	Pack Weight pcs. kg/pc.	Wiring Diagram
K3-10ND10= ...	24V= DC	1 0,25	A10=
K3-10ND01= ...	60V= DC	1 0,25	
K3-14ND10= ...	110V= DC	1 0,25	A01=
K3-14ND01= ...	220V= DC	1 0,25	
K3-18ND10= ...	24V= DC	1 0,25	
K3-18ND01= ...	60V= DC	1 0,25	
K3-22ND10= ...	110V= DC	1 0,25	
K3-22ND01= ...	220V= DC	1 0,25	
K3-24A00= ...	24V= DC	1 0,55	... A00=
K3-32A00= ...	60V= DC	1 0,55	
K3-40A00= ...	110V= DC	1 0,55	

Contactors 4-pole

AC Operated



Ratings		Rated Current	Aux. Contacts		Type	Coil voltage ²⁾		Pack Weight pcs. kg/pc.	Wiring Diagram
AC2	AC1		Built-in	Additional		24	110		
380V		AC1		see page 34		24V 50/60Hz			
400V		690V	NO NC	Type		110V 50/60Hz			
415V	400V					230 220-240V 50Hz		400 380-415V 50Hz	
kW	kW	A							
4	17,5	25	-	-	max. 4				
5,5	17,5	25	-	-	HN.. or				
					HA..				
7,5	22	32	-	-					
11	22	32	-	-					
11	31	45	-	-	max. 4				
15	34,5	50	-	-	HN..				
18,5	34,5	50	-	-	or				
					HA..				
22	55	80	-	-	max. 6				
30	69	100	-	-	HN.. or				
					HA..				
55	139	200	-	-	1HKT..				
75	159	230	-	-	+				
90	173	250	-	-	2xHKA11				
110	242	350	-	-					
132	310	450	-	-					
160	346	500	-	-					

Type	Coil voltage ²⁾	Pack Weight pcs. kg/pc.	Wiring Diagram
K3-10NA00-40 ...	24V 50/60Hz	1 0,22	A00-40
K3-14NA00-40 ...	110V 50/60Hz	1 0,22	
K3-18NA00-40 ...	230 220-240V 50Hz	1 0,22	
K3-22NA00-40 ...	400 380-415V 50Hz	1 0,22	
K2-23A00-40 ...	24V 50/60Hz	1 0,65	
K2-30A00-40 ...	110V 50/60Hz	1 0,65	
K2-37A00-40 ...	230 220-240V 50Hz	1 0,65	
K2-45A00-40 ...	400 380-415V 50Hz	1 1,1	
K2-60A00-40 ...	24V 50/60Hz	1 1,1	
K3-116A00-40 ... ³⁾	110V 50/60Hz	1 4,7	
K3-151A00-40 ... ³⁾	230 220-240V 50Hz	1 4,7	
K3-176A00-40 ... ³⁾	400 380-415V 50Hz	1 4,7	
K3-210A00-40 ... ³⁾	24V 50/60Hz	1 8	
K3-260A00-40 ... ³⁾	110V 50/60Hz	1 8	
K3-316A00-40 ... ³⁾	230 220-240V 50Hz	1 8	

Latch for Contactors 4-pole see page 36

1) Other coil voltages on request

2) Coil voltage range and non-standard coil voltages see page 39

3) with integrated coil suppressor

Capacitor Switching Contactors

for use with reactive or non-reactive capacitor banks



Rated Operational Power at 50/60Hz Ambient Temperature						Aux. Contacts Built-in Add.		Type	Coil voltage ¹⁾ 220-240V 50Hz	Pack pcs.	Weight kg/pc.
50°C			60°C			NO	NC		230 ↓		
380V 400V kVAr	415V 440V kVAr	660V 690V kVAr	380V 400V kVAr	415V 440V kVAr	660V 690V kVAr						
0-12,5	0-13	0-20	0-12,5	0-13	0-20	1	-	1 ²⁾	K3-18NK10 ...	1	0,34
0-12,5	0-13	0-20	0-12,5	0-13	0-20	-	1	1 ²⁾	K3-18NK01 ...	1	0,34
10-20	10,5-22	17-33	10-20	10,5-22	17-33	-	-	3 ³⁾	K3-24K00 ...	1	0,62
10-25	10,5-27	17-41	10-25	10,5-27	17-41	-	-	3 ³⁾	K3-32K00 ...	1	0,62
20-33,3	23-36	36-55	20-33,3	23-36	36-55	-	-	3 ³⁾	K3-50K00 ...	1	1,0
20-50	23-53	36-82	20-50	23-53	36-82	-	-	3 ³⁾	K3-62K00 ...	1	1,0
20-75 ⁴⁾	23-75 ⁴⁾	36-120 ⁴⁾	20-60	23-64	36-100	-	-	3 ³⁾	K3-74K00 ...	1	1,0
33-80	36-82	57-120	33-75	36-77	57-120	-	-	6 ⁵⁾	K3-90K00 ...	1	2,3
33-100 ⁶⁾	36-103 ⁶⁾	57-148 ⁶⁾	33-90 ⁶⁾	36-93 ⁶⁾	57-148 ⁶⁾	-	-	6 ⁵⁾	K3-115K00 ...	1	2,3

Specification: Contactors K3-.K are suitable for switching low-inductive and low loss capacitors in capacitor banks (IEC70 and 831, VDE 0560) without and with reactors.

Capacitor switching contactors are fitted with early make contacts and damping resistors, to reduce the value of make current $< 70 \times I_g$.

Operating Conditions: Capacitor switching contactors are protected against contact welding for a prospective making current of $200 \times I_g$.

Technical Data acc. to IEC 947-4-1, IEC 947-5-1, EN 60947-4-1, EN 60947-5-1, VDE 0660

Type		K3-18K	K3-24K	K3-32K	K3-50K	K3-62K	K3-74K	K3-90K	K3-115K	
Max. frequency of operations z	1/h	120	120	120	120	120	80	80	80	
Contact life	non reactive capacitor banks	$S \times 10^3$	250	150	150	150	120	120	120	
	reactive capacitor banks	$S \times 10^3$	400	300	300	300	200	200	200	
Rated operational current I_g AC6b	at 50°C	A	0-18	14-28	14-36	30-48	30-72	30-108	50-115	50-144
	at 60°C	A	0-18	14-28	14-36	30-48	30-72	30-87	50-108	50-130
Rated operational current I_{th} AC1	at 50°C	A	32	45	60	100	110	120	155	190
	at 60°C	A	32	40	55	90	100	110	145	170
Overload factor acc. to EN 61921: 30% min.	at 50°C	%	78	60	67	108	53	11	35	32
	at 60°C	%	78	43	53	88	39	26	34	31
Fuses gL (gG)	from / to	A	35 / 63	50 / 80	63 / 100	80 / 160	125 / 160	160/200	160/200	160/250

Typical Circuit Diagram

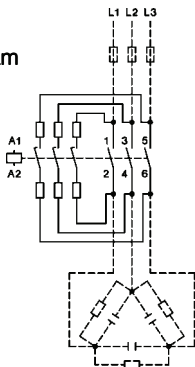

Wiring Diagram for Quick Discharge Resistors

Make sure that the current of the discharge resistors is not higher than the rated current (AC1) of the auxiliary contacts

Mounting instructions:

In the area of capacitor switching contactors, difficulty inflammable and self-extinguishing materials shall be used only, because abnormal temperatures within the area of the resistor spirals cannot be excluded.

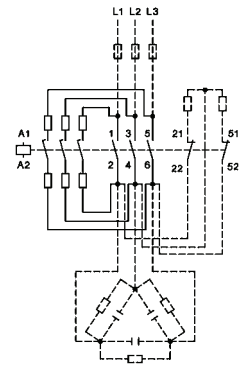

1) Coil voltage range and non-standard coil voltages see page 39

2) 1 HN.. or HA.. snap-on

3) 2HB.. for side mounting and 1 HN.. or HA.. snap-on

4) Consider the max. thermal current of the contactor K3-74A: I_{th} 130A

5) 2 HB.. on the left or right side and 4 HN.. or HA.. snap-on

6) Consider the min. cross-section of conductor at max. load

Auxiliary Contact Blocks for contactors K(G)3-07.. to K3-115.., type HN.. for low level switching ¹⁾



Rated AC15 230V A	Operational Current		Contacts	Type	Pack	Weight
	AC15 400V A	AC1 690V A				
3	2	10	NO	HN10	10	0,02
3	2	10	NC	HN01	10	0,02
3	2	10	EM	HN10U	10	0,02
3	2	10	LB	HN01U	10	0,02
6	3	25	NO	HA10	10	0,03
6	3	25	NC	HA01	10	0,03

Auxiliary Contact Block for contactors K3-24.. to K3-115.., for low level switching ¹⁾



Rated AC15 230V A	Operational Current		Contacts	Type	Pack	Weight
	AC15 400V A	AC1 690V A				
3	2	10	NO	HB11	10	0,02
3	2	10	NC	HB02	10	0,02

mounting:
1 HB.. on left side
and 1 HB.. on right side

Auxiliary Contact Blocks for contactors K3-116.. to K3-1200



Rated AC15 230V A	Operational Current		Contacts	Type	Pack	Weight
	AC15 400V A	AC1 690V A				
3	2	10	NO	HKT11	1	0,04
3	2	10	NC	HKT22	1	0,05
3	2	10	NO	HKA11	1	0,05
6	3	16	2 ²⁾	HKF22	1	0,12
6	3	16	1	HKB11	1	0,17

For contactors

Snap-on Momentary Contacts for K(G)3-07.. to K3-115.. for low level switching ¹⁾



Rated AC15 230V A	Operational Current		Contacts	Type	Pack	Weight
	AC15 400V A	AC1 690V A				
3	2	10	NO	HTN10	10	0,02
3	2	10	NC	HTN01	10	0,02

Specification

Terminal Blocks for contactors K(G)3-07.. to K3-115.. and K2-..



Specification	Thermal Current I _{th} A	Type	Pack pcs.	Weight kg/pc.
2 terminals interconnected	26	K2-DK	10	0,02
2 terminals insulated	26	K2-SK	10	0,02

¹⁾Contacts suitable for electronic circuits, according to IEC60947-5-4 for rated voltage 24V DC (test ratings 17V DC, 5mA) Positively guided contacts
Technical data see page 62

²⁾Contact travel of make contacts adjustable, see page 63

Pneumatic Timer for contactors K(G)3-07.. to K(G)3-40.. and K2-07 to K2-16

Timer must be snapped onto the contactor, mechanically operated by the contactor and occupies 4 add-on spaces. The contacts of the timer switch delayed to the contacts of the contactor.



Function	Time Range s	Contacts				Type	Pack	Weight
		NO	NC	NO	NC		pcs.	kg/pc.
On-delay	0,1 - 40	1	1	-	-	K2-TP40DE	1	0,09
On-delay	10 - 180	1	1	-	-	K2-TP180DE	1	0,09
Off-delay	0,1 - 40	-	-	1	1	K2-TP40IA	1	0,09
Off-delay	10 - 180	-	-	1	1	K2-TP180IA	1	0,09

Electronic Timer On-delay for contactors K(G)3-07.. to K3-115.. and K2-..

Timer will be connected with the contactor coil, can be snapped onto the contactor and occupies 2 add-on spaces. Contactor switches On-delay.



Operational Voltage V	Time Range s	Rated Current AC15 A	Type	Pack pcs.	Weight kg/pc.
24 - 60V AC/DC	1 - 30	0,75	K2-TE30 60	1	0,08
100 - 250V AC/DC	1 - 30	0,75	K2-TE30 250	1	0,08
24 - 60V AC/DC	10 - 180	0,75	K2-TE180 60	1	0,08
100 - 250V AC/DC	10 - 180	0,75	K2-TE180 250	1	0,08
24 - 60V AC/DC	30 - 600	0,75	K2-TE600 60	1	0,08
100 - 250V AC/DC	30 - 600	0,75	K2-TE600 250	1	0,08

Wiring Diagram

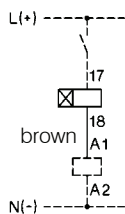

Timing Chart

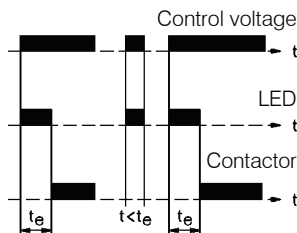

Operation Range

Time repeat accuracy
Recovery time (typical)

$0,8 - 1,1 \times U_s$
 $\leq 1\%$
50ms

Voltage Drop after the time delay t_e
(Control voltage 24V: use contactor with 20V-coil)
Max. inrush current (peak value)

< 3V
25A < 10ms

Duty Cycle

Ambient temperature
Short circuit protection

100%
-40° - +60°C
2A

Electronic Timer Off-delay for contactors K(G)3-07.. to K3-74.. and K2-..

Timer will be connected with the contactor coil, can be snapped onto the contactor and occupies 2 add-on spaces. Contactor switches Off-delay.



Operational Voltage V	Time Range s	Rated Current AC15 A	Type	Pack pcs.	Weight kg/pc.
24 - 60V AC	1 - 30	0,75	K2-TA30 60	1	0,08
100 - 120V AC	1 - 30	0,3	K2-TA30 120	1	0,08
200 - 250V AC	1 - 30	0,15	K2-TA30 250	1	0,08
24 - 60V AC	10 - 180	0,75	K2-TA180 60	1	0,08
100 - 120V AC	10 - 180	0,3	K2-TA180 120	1	0,08
200 - 250V AC	10 - 180	0,15	K2-TA180 250	1	0,08
24 - 60V AC	30 - 600	0,75	K2-TA600 60	1	0,08
100 - 120V AC	30 - 600	0,3	K2-TA600 120	1	0,08
200 - 250V AC	30 - 600	0,15	K2-TA600 250	1	0,08

Wiring Diagram

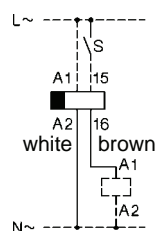

Timing Chart

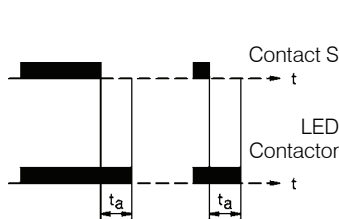

Operation Range

Time repeat accuracy
Min. start time
Recovery time (typical)

$0,8 - 1,1 \times U_s$
 $\leq 1\%$
15ms
15ms

Voltage Drop
Max. inrush current (peak value)

< 0,7V
25A < 10ms

Duty Cycle

Ambient temperature
Short circuit protection

100%
-40° - +40°C
2A

Utilization Category AC15

24 - 60V	100 - 120V	200 - 250V
0,75A	0,3A	0,15A

Interface for contactors K3-07.. to K3-74.. and K2-07.. to K2-60..



Input Voltage U _e	Power Consumption	Rated Current I _e AC15	250V AC	400V AC	Type	Pack pcs.	Weight kg/pc.
24V DC	0,35W	0,75A	0,5A		K2-IM	1	0,03

Amplifier element for contactor control by programmable controller

Fuse Holders for contactors K(G)3-07.. to K3-115.. and K2-..



Specifications	Rated Voltage	Type	Pack pcs.	Weight kg/pc.
Fuse holder for fuse 5x20mm (max. 6,3A) Fuses are not included.	250V AC	K2-F	1	0,02

Rectifier with Fuse Holder for contactors K(G)3-07.. to K3-115.. and K2-..

Specifications	Rated Voltage	Type	Pack pcs.	Weight kg/pc.
with built-in rectifier 1A	250V AC	K2-RF1	1	0,03
with built-in rectifier 3A	250V AC	K2-RF3	1	0,03

Latch for contactors K(G)3-07.. to K3-74.. and K2-..

with NC aux. contact
power consumption max. 30VA

Type	Coil voltage	Pack pcs.	Weight kg/pc.
24	22-26V 50/60Hz		
110	100-120V 50/60Hz		
230	210 -250V 50/60Hz		
400	360-440V 50/60Hz		
↓			

For Contactors

K3-07 to K3-22, K2-07 to K2-16	K2-L22 . . .	1	0,08
K3-24 to K3-40, K2-23 to K2-37, KG3-10 to KG3-40	K2-L40 . . .	1	0,08
K3-50 to K3-74, K2-45 to K2-60	K2-L74 . . .	1	0,08

Technical data see page 62
Latch for Contactors K3-200 to K3-860 on request

Indicator Units for contactors K(G)3-07.. to K3-115.. and K2-..



Specifications	Voltage Range	Type	Pack pcs.	Weight kg/pc.
Coil Current Indicator , green (LED)	24 - 660V AC/DC	K2-ING	10	0,02
Coil Current Indicator , red (LED)	24 - 660V AC/DC	K2-INR	10	0,02
To connect in series with the contactor coil. In case of coil interruption the indication goes out. Voltage drop appr. 2 volts				
Voltage Indicator , clear (glow-disc. I.)	220 - 415V AC/DC	K2-UN	10	0,02
Voltage Indicator , red (LED)	24 - 120V AC/DC	K2-UNR	10	0,02
To connect parallel to the contactor coil. In case of applied voltage the indication also lights at coil interruption.				

Snap-On Adapter



For Type	Specification	Type	Pack pcs.	Weight kg/pc.
K2-DK, K2-SK, K2-TE, K2-TA K2-IM, K2-F, K2-RF K2-IN., K2-UN.	for snap-on mounting of accessories on 35mm DIN-rail acc. DIN EN 50022	K2-SM	10	0,009

Additional 4th Poles for contactors K3-315.. to K3-1200



For Contactors	Thermal Current I _{th} A	Type	Pack pcs.	Weight kg/pc.
K3-315, K3-450, K3-550	325	NP325	1	0,7
K3-315, K3-450, K3-550	500	NP500	1	1,3
K3-450, K3-550	760	NP760	1	1,4
K3-700, K3-860	500	NP501	1	1,3
K3-700, K3-860	1000	NP1000	1	1,6
K3-1000, K3-1200	1000	NP1001	1	1,6

Mechanical Interlocks



Interlocks contactor with contactor Type	Type	Mounting	Type	Pack pcs.	Weight kg/pc.
K3-07 to K3-40 KG3-07 to KG3-22 KG3-24 to KG3-40 K2-07 to K2-37	K3-07 to K3-40 KG3-07 to KG3-22 KG3-24 to KG3-40 K2-07 to K2-37	horizontal	LG10889 ¹⁾	10	0,006
K3-24 to K3-74 K2-23 to K2-60	K3-50 to K3-74 K2-45 to K2-60	horizontal	LG10890 ¹⁾	1	0,010
K3-90, K3-115 K65 to K110	K3-90, K3-115 K65 to K110	horizontal	LG11478 ¹⁾ LG8511	1	0,010 0,076
K3-116 to K3-316	K3-116 to K3-316	horizontal	LG11223H	1	0,06
K3-315 to K3-550 K3-315 to K3-550 K3-450, K3-550 K3-450, K3-550	K3-315 to K3-550 K3-315 to K3-550 K3-700, K3-860 K3-700, K3-860	horizontal vertical horizontal vertical	LG10400H LG10400V LG10399H LG10399V	1 1 1 1	0,8 0,8 1,6 0,9
K3-700, K3-860 K3-700, K3-860 K3-700, K3-860 K3-700, K3-860	K3-700, K3-860 K3-700, K3-860 K3-1000, K3-1200 K3-1000, K3-1200	horizontal vertical horizontal vertical	LG10402H LG10402V LG10401H LG10401V	1 1 1 1	1,5 0,9 1,9 1,6
K3-1000, K3-1200 K3-1000, K3-1200	K3-1000, K3-1200 K3-1000, K3-1200	horizontal vertical	LG10403H LG10403V	1 1	1,8 1,5

1) clamps for mounting incl.

Terminal Covers for terminal protection according to DIN 57106, VBG 4

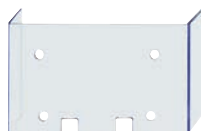

For Contactors	Specification	Type	Pack pcs.	Weight kg/pc.
K65 to K110 (spare part)	for 6 terminals	LG9333	1	0,045
K3-151, K3-176 3-pole	for 3 terminals	LG10404	1	0,12
K3-116 to K3-176 4-pole	for 4 terminals	LG104044	1	0,14
K3-210, K3-260, K3-316	for 3 terminals	LG11457	1	0,14
K3-200	for 3 terminals	LG10405	1	0,18
K3-315, K3-450	for 3 terminals	LG10406	1	0,28
K3-550	for 3 terminals	LG10407	1	0,34
K3-700	for 3 terminals	LG10408	1	0,39
K3-860	for 3 terminals	LG10409	1	0,49

Additional Terminals



For Contactors	Cable Cross-sections to clamp mm ² solid or flex. with multi- stranded flexible core cable end			Type	Pack pcs.	Weight kg/pc.
Additional Terminal Single Pole, with fingertouch protection						
K(G)3-10 to K(G)3-22 K2-09 to K2-16	0,75 - 10	0,75 - 6	0,75 - 6	LG9339	6	0,009
K3-151 to K3-176	16 - 120 + 16 - 95			LG11224	1	0,10
Additional Terminal Single Pole, set with 3 pieces						
K3-50 to K3-74, K2-45, K2-60	4 - 35	6 - 25	4 - 25	LG9030	1	0,052
K3-50 to K3-74 K2-45, K2-60	10 - 70	16 - 50	10 - 35	LG9031	1	0,170

Parallel Connectors

For Contactors	Cable Cross-sections to clamp	mm ² solid or stranded	flexible	flex. with multi-core cable end	Type	Pack pcs.	Weight kg/pc.
----------------	-------------------------------	-----------------------------------	----------	---------------------------------	------	-----------	---------------



Parallel Connectors, 3 Poles Parallel

Current-carrying capacity: 2,5 x AC1-value of the contactor

K(G)3-10 to K(G)3-22	terminal hole for screw M5	Type	Pack pcs.	Weight kg/pc.
K2-09 to K2-16		LG9241	50	0,004
K2-23 to K2-37	4 - 35 6 - 25 4 - 25	LG5587	10	0,022

Parallel Connectors, 4 Poles Parallel

Current-carrying capacity: 3,2 x AC1-value of the contactor

K(G)3-10 to K(G)3-22	terminal hole for screw M5	Type	Pack pcs.	Weight kg/pc.
K2-09 to K2-16		LG7360	10	0,006

Suppressor Units



Voltage Range V	Mounting	Type	Pack pcs.	Weight kg/pc.
-----------------	----------	------	-----------	---------------

RC-units for contactors K3-07 - K3-74

12 - 48V AC/DC	to snap	1600nF / 22 Ohm	RC-K3N 24	10	0,01
48 - 127V AC/DC	on the	680nF / 270 Ohm	RC-K3N 110	10	0,01
110 - 230V AC/DC	contactor	220nF / 2200 Ohm	RC-K3N 230	10	0,01
230 - 415V AC/DC		120nF / 4700 Ohm	RC-K3N 400	10	0,01

Mounting Parts



Description	For Type	Specification	Type	Pack pcs.	Weight kg/pc.
Clamp, no distance	K3-07 to K3-115 K2-07 to K2-37	To join contactors without distance, 2 pieces required	P426-1	50	0,001
Clamp, 7mm distance	K3-07 to K3-115 K2-07 to K2-37	To join contactors with 7mm distance, 2 pieces required	P418-1	10	0,002
Clamp, 12mm distance	K3-07 to K3-115 K2-07 to K2-37	To join contactors with 12mm distance, 2 pieces required	P807-1	10	0,002
Clamp asymmetric	K3-07 to K3-40 with K3-50 - K3-74	To join contactors with 12mm distance, 2 pieces required	P785-1	10	0,002

Marking System for contactors K3-07.. to K3-115.., K2-.. and aux. contact blocks HN and HA



Description	Specification	Type	Pack pcs.	Weight kg/100pc
Marking Plate	2-section without marking, divisible	P487-1	100	0,025
Marking Plate	3-section without marking, divisible	P971-1	100	0,038
Marking Plate	4-section without marking, divisible	P245-1	100	0,050
Marking Plate	marked, choice of K1...K32	P245-K..	100	0,013

Coil voltages for AC operated contactors

Type-suffix for coil-types K6/.. to K45/...
for contactor-types K3-07.. to K3-74

Suffix to contactor type	to coil type	Voltage Marking		Rated Control Voltage U _s			
		at the coil for 50Hz V	for 60Hz V	range for 50Hz min. max. V V		for 60Hz min. max. V V	
6	41.6	6		6	6,6	6,6	7,3
6,6	41.6,6	6,6		6,6	7,3	7,3	8
7,3	41.7,3	7,3		7,3	8	8	9
8	41.8	8		8	9	9	10
9	41.9	9		9	10	10	11
10	41.10	10		10	11	11	12
11	41.11	11	12	11	12	12	13,2
12	41.12	12		12	13,2	13,2	14,5
13,2	41.13	13,2		13,2	14,5	14,5	16
14,5	41.14	14,5		14,5	16	16	18
16	41.16	16		16	18	18	20
18	41.18	18		18	20	20	22
20	41.20	20		20	22	22	24
24	4.24	24	24	22	24	24	27
25	41.25	25		24	27	27	30
27	41.27	27	32	27	30	30	33
31	41.32	32	36	30	33	33	36
33	41.33	36	36	33	36	36	39
36	41.36	36	42	36	39	39	42
40	41.40	42	42	39	42	42	47
42	4.42	42	48	42	47	47	52
48	41.48	48	48	44	48	48	52
55	41.55	55	60	52	58	58	65
60	41.60	60		58	65	65	72
65	41.65	65		65	72	72	80
75	41.75	75		72	80	80	90
85	41.85	85		80	90	90	100
90	41.90	100	100	90	100	100	110
110	4.110	110	110-120	100	110	110	122
115	41.115	115	125	110	122	122	135
127	41.127	127		122	135	135	150
140	41.140	140		135	150	150	165
150	41.150	150		150	165	165	180
165	41.165	165	180-208	165	180	180	208
180	41.180	180-210 ¹⁾	200-240 ¹⁾	180	210 ¹⁾	200	240 ¹⁾
200	41.200	200-230 ¹⁾	220-240	200	230 ¹⁾	220	240
230	4.230	220-240	230-264	220	240	230	264
254	41.254	254	277	240	264	264	290
270	41.270	270		264	290	290	315
300	41.300	300		290	315	315	345
320	41.320	320		315	345	345	380
345	41.345	345-400 ¹⁾	380-440 ¹⁾	345	400 ¹⁾	380	440 ¹⁾
400	4.400	380-415	400-440	380	415	400	460
415	41.415	415-440	440-480	400	440	440	480
440	41.440	440-480	480-500	440	480	480	530
480	41.480	480-500	530-580	480	530	530	580
500	41.500	500-550	550-600	500	550	550	600
550	41.550	550-600	600	550	600	600	(650)

Standard voltages in bold type letters

Type-suffix for coil-types K85/... and K110/...
for contactor-types K85 to K110

Suffix to contactor type	to coil type	Voltage Marking		Rated Control Voltage U _s			
		at the coil for 50Hz V	for 60Hz V	range for 50Hz min. max. V V		for 60Hz min. max. V V	
20	4.20	20	24	20	22	24	26
24	4.24	24		24	27	29	32
42	4.42	42		42	47	50	56
110	4.110	110-120		110	122	132	146
230	4.230	220-240	277	220	240	264	288
400	4.400	380-415	460-480	380	415	455	498

Type-suffix for coil-types K3-1200/...
for contactor-types K3-1000.. to K3-1200..

110	4.110	110-115	-	110	115	110	115
230	4.230	220-230	-	220	230	220	230
400	4.400	380-400	-	380	400	380	400
440	4.440	440	-	440	440	440	440

Coil voltages for AC and DC operated contactors

Type-suffix for coil-types K3-115/.. to K3-860/...
for contactor-types K3-90.. to K3-860..

Suffix to contactor type	to coil type	Voltage Marking		Rated Control Voltage U _s			
		at the coil for 50/60Hz V	for DC V	range for 50Hz min. max. V V		for 60Hz min. max. V V	
24	4.24	24	24	22	24	22	24
48	4.48	48	48	44	48	44	48
110	4.110	110-120	110	110	120	110	120
230	4.230	220-240	220	220	240	220	240
400	4.400	380-415	-	380	415	380	415

Operating range of magnet-coils: 0,85 x U_s (min. value of rated control voltage) up to 1,1 x U_s (max. value of rated control voltage)

With reduced control voltage range 0,9 up to 1,0 x U_s at ambient temperature 60 - 90°C

1) Operating range of magnet-coils: 0,85 x U_s (min. value of rated control voltage) up to 1,05 x U_s (max. value of rated control voltage)

Spare Coils for AC operated contactors



		Type	Coil voltage ¹⁾	Pack pcs.	Weight kg/pc.
		4.24	24V 50Hz		
		4.42	42V 50Hz		
		4.110	110V 50Hz		
		41.180	180V 50Hz, 220V 60Hz		
		4.230	220-240V 50Hz		
		4.400	380-415V 50Hz		
For Contactors		↓			
K3-07N.. up to K3-22N..		K10N/ . . .EUR		1	0,053
K3-07.. up to K3-22..		K3-6/ . . .		10	0,040
K2-07.. up to K2-16..		K6/ . . .		10	0,040
K3-24.. up to K3-40..		K24/ . . .		1	0,085
K2-23.. up to K2-37..		K23/ . . .		1	0,085
K3-50.. up to K3-74.., K2-45.., K2-60..		K45/ . . .		1	0,110
K65.., K85..		K85/ . . .		1	0,215
K110..		K110/ . . .		1	0,220
		Type	Coil voltage ¹⁾	Pack pcs.	Weight kg/pc.
		4.110	110V 50Hz, 110-115V 60Hz		
		4.230	220-230V 50Hz		
		4.400	380-400V 50Hz		
For Contactors		▼			
K3-150.., K3-175..		K3-175/ . . .		1	0,38
K3-1000.., K3-1200..	without feeder group ²⁾	K3-1200/ . . .		1	3,12

Spare Coils for AC and DC operated contactors



		Type	Coil voltage ¹⁾	Pack pcs.	Weight kg/pc.
		4.24	24V 50/60Hz / 24V DC		
		4.110	110-120V 50/60Hz / 110V DC		
		4.230	220-240V 50/60Hz / 220V DC		
		4.400	380-415V 50/60Hz		
For Contactors		▼			
K3-90.., K3-115..	with feeder group	K3-115/ . . .		1	0,30
K3-151.., K3-176..	with feeder group	K3-176/ . . .		1	0,68
K3-210.., K3-316..	with feeder group	K3-316/ . . .		1	0,68
K3-450.., K3-550..	without feeder group ²⁾	K3-550/ . . .		1	1,63
K3-700.., K3-860..	without feeder group ²⁾	K3-860/ . . .		1	2,44

Spare Feeder Groups for contactors K3-450.. to K3-860..

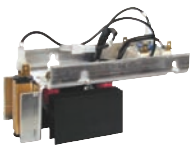

		Type	Coil voltage ¹⁾	Pack pcs.	Weight kg/pc.
In case of changing control voltage, change coil and feeder group too		110	110-120V 50/60Hz / 110V DC		
		230	220-240V 50/60Hz / 220V DC		
		400	380-415V 50/60Hz		
For Contactors		↓			
K3-450.., K3-550..	for coils K3-550/4...	K3-550/FG . . .		1	0,33
K3-700.., K3-860..	K3-860/4..	K3-860/FG . . .		1	0,54

1) Coil voltage range and non-standard coil voltages see page 39

2) In case of changing control voltage, change coil and feeder group too

Spare Coils for DC operated contactors



For Contactors		Aux. Contact Block for double winding coil	Type	Coil voltage ¹⁾	Pack pcs.	Weight kg/pc.
			47.24	24V DC		
			47.110	110V DC		
			47.220	220V DC		
			↓			
K3-07N..= up to K3-22N..=	HN01U	K10N/ ...			1	0,052
K3-07..= up to K3-22..=	HN01U	K3-6/ ...			1	0,042
K2-07..= up to K2-16..=	HN01U	K6/ ...			1	0,042
K3-24..= up to K3-40..=	HN01X	K24/ ...			1	0,090
K2-23..= up to K2-37..=	HN01X	K23/ ...			1	0,090
K3-50..= up to K3-74..=, K2-45..=, K2-60..=	HN01Z	K45/ ...			1	0,115
K65..=, K85..=	-	K85/ ...			1	0,220
K110..=	-	K110/ ...			1	0,225
For Contactors			Type	Coil voltage ¹⁾	pcs.	kg/pc.
			43.110	110V DC		
			43.220	220V DC		
			▼			
K3-1000..=, K3-1200..=	without feeder group ²⁾	K3-1200/ ...			1	3,12

Wiring Diagrams for Coil Circuit

AC operated,

K3-07..
up to **K110..**



DC operated
with double winding coil

K3-07..=
up to **K3-22..=**

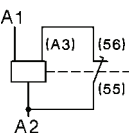

DC operated

KG3..

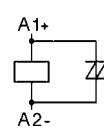

AC and DC operated
with double winding coil
K3-90A00, K3-115A00
K3-151A00, K3-176A00
K3-210A00 to K3-316A00

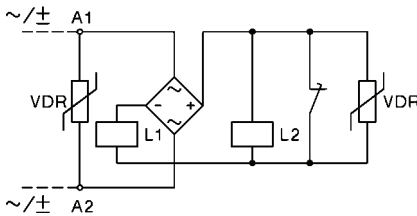

K3-24..=
to
K3-74..=

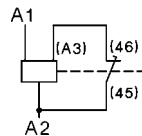

AC and DC operated
with series resistor
K3-200A21
K3-315A21

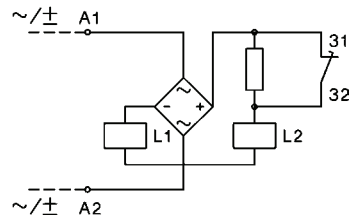

AC and DC operated
with series resistor
K3-450.. up to K3-860..

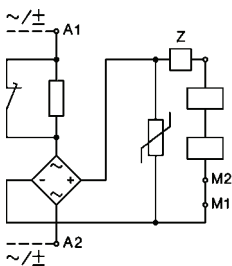

DC operated
with DC coil
K3-1000.., K3-1200..

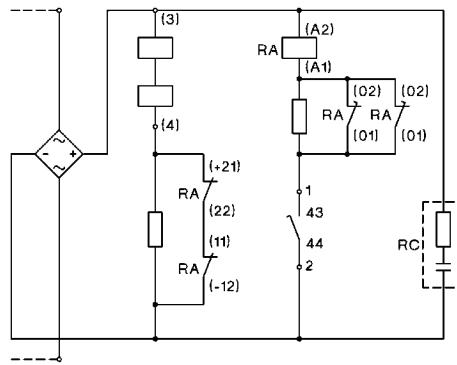

AC operated
with DC coil
K3-1000.., K3-1200..

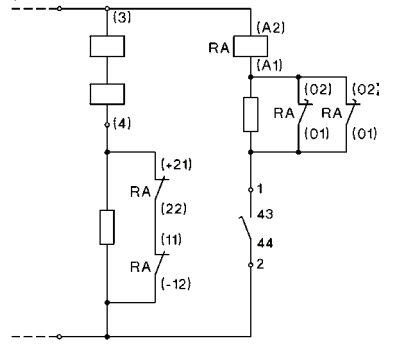

Adjustable dropout operating time for K3-450.. to K3-860..
150-200ms: Wiring see above (delivery standard)
500-1000ms: Jumper device "Z"
approx. 20ms: Special wiring see package folder

Contactors K3-1000.., K3-1200..
For control voltages up to 125V
NC contacts 21-22 and 11-12 are connected parallel,
for higher voltages contacts are connected in series (delivery standard).

1) Other coil voltages on request

2) In case of changing control voltage, change coil and feeder group too

Spare Contacts



Main Contacts for Contactors	Type	Pack pcs.	Weight kg/pc.
K85..	EK85/1	3	0,235
K110..	EK110/1	3	0,275
K3-150..	EK3-150/10	1	0,32
K3-151..	EK3-151/10	1	0,16
K3-175..	EK3-175/10	1	0,32
K3-176..	EK3-176/10	1	0,16
K3-200..	EK3-200/10	1	0,18
K3-210..	EK3-210/10	1	
K3-260..	EK3-260/10	1	
K3-315..	EK3-315/10	1	0,34
K3-316..	EK3-316/10	1	
K3-450..	EK3-450/10	1	0,35
K3-550..	EK3-550/10	1	0,35
K3-700..	EK3-700/10	1	0,85
K3-860..	EK3-860/10	1	1,0
K3-1000..	EK3-1000/10	1	1,4
K3-1200..	EK3-1200/10	1	1,4

Approximate Values for three-phase Motors

Motor Full Load Currents

Approximate values of motor F.L.C. and minimum "slow blow" respectively "gL" short-circuit fuse

Motor rating kW	Range according to BS for 415V F.L.C.				220-230V Value of Motor of fusing at motor start			240V Value of Motor of fusing at motor start			380-400V Value of Motor of fusing at motor start			415V Value of Motor of fusing at motor start			500V Value of Motor of fusing at motor start			660-690V Value of Motor of fusing at motor start		
	PS~hp	hp	cosφ	%	D.O.L. A	YD A	F.L.C. A	D.O.L. A	YD A	F.L.C. A	D.O.L. A	YD A	F.L.C. A	D.O.L. A	YD A	F.L.C. A	D.O.L. A	YD A	F.L.C. A	D.O.L. A	YD A	F.L.C. A
0,06	0,08	-	0,7	59	0,38	1	1	0,35	1	1	0,22	1	1	-	-	-	0,16	1	1	-	-	-
0,09	0,12	-	0,7	60	0,55	2	2	0,5	2	2	0,33	1	1	-	-	-	0,24	1	1	-	-	-
0,12	0,16	-	0,7	61	0,76	2	2	0,68	2	2	0,42	2	2	-	-	-	0,33	1	1	-	-	-
0,18	0,24	-	0,7	61	1,1	2	2	1	2	2	0,64	2	2	-	-	-	0,46	1	1	-	-	-
0,25	0,34	-	0,7	62	1,4	4	2	1,38	4	2	0,88	2	2	-	-	-	0,59	2	2	-	-	-
0,37	0,5	-	0,72	64	2,1	4	4	1,93	4	4	1,22	4	2	-	-	-	0,85	2	2	0,7	2	2
0,55	0,75	-	0,75	69	2,7	4	4	2,3	4	4	1,5	4	2	-	-	-	1,2	4	2	0,9	2	2
0,75	1	1	0,8	74	3,3	6	4	3,1	6	4	2	4	4	2	4	4	1,48	4	2	1,1	2	2
1,1	1,5	1,5	0,83	77	4,9	10	6	4,1	6	6	2,6	4	4	2,5	4	4	2,1	4	4	1,5	4	2
1,5	2	2	0,83	78	6,2	10	10	5,6	10	10	3,5	6	4	3,5	6	4	2,6	4	4	2	4	4
2,2	3	3	0,83	81	8,7	16	10	7,9	16	10	5	10	6	5	10	6	3,8	6	6	2,9	6	4
2,5	3,4	-	0,83	81	9,8	16	16	8,9	16	10	5,7	10	10	-	-	-	4,3	6	6	-	-	-
3	4	4	0,84	81	11,6	20	16	10,6	20	16	6,6	16	10	6,5	16	10	5,1	10	10	3,5	6	4
3,7	5	5	0,84	82	14,2	25	20	13	25	16	8,2	16	10	7,5	16	10	6,2	16	10	-	-	-
4	5,5	-	0,84	82	15,3	25	20	14	25	20	8,5	16	10	-	-	-	6,5	16	10	4,9	10	6
5,5	7,5	7,5	0,85	83	20,6	35	25	18,9	35	25	11,5	20	16	11	20	16	8,9	16	10	6,7	16	10
7,5	10	10	0,86	85	27,4	35	35	24,8	35	35	15,5	25	20	14	25	16	11,9	20	16	9	16	10
8	11	-	0,86	85	28,8	50	35	26,4	35	35	16,7	25	20	-	-	-	12,7	20	16	-	-	-
11	15	15	0,86	87	39,2	63	50	35,3	50	50	22	35	25	21	35	25	16,7	25	20	13	25	16
12,5	17	-	0,86	87	43,8	63	50	40,2	63	50	25	35	35	-	-	-	19	35	25	-	-	-
15	20	20	0,86	87	52,6	80	63	48,2	80	63	30	50	35	28	35	35	22,5	35	25	17,5	25	20
18,5	25	25	0,86	88	64,9	100	80	58,7	80	63	37	63	50	35	50	50	28,5	50	35	21	35	25
20	27	-	0,86	88	69,3	100	80	63,4	80	80	40	63	50	-	-	-	30,6	50	35	-	-	-
22	30	30	0,87	89	75,2	100	80	68	100	80	44	63	50	40	63	50	33	50	50	25	35	35
25	34	-	0,87	89	84,4	125	100	77,2	100	100	50	80	63	-	-	-	38	63	50	-	-	-
30	40	40	0,87	90	101	125	125	92,7	125	100	60	80	63	55	80	63	44	63	50	33	50	35
37	50	50	0,87	90	124	160	160	114	160	125	72	100	80	66	100	80	54	80	63	42	63	50
40	54	-	0,87	90	134	160	160	123	160	160	79	100	100	-	-	-	60	80	63	-	-	-
45	60	60	0,88	91	150	200	160	136	200	160	85	125	100	80	100	100	64,5	100	80	49	63	63
51	70	-	0,88	91	168	200	200	154	200	200	97	125	100	-	-	-	73,7	100	80	-	-	-
55	75	-	0,88	91	181	250	200	166	200	200	105	160	125	-	-	-	79	125	100	60	80	63
59	80	80	0,88	91	194	250	250	178	250	200	112	160	125	105	160	125	85,3	125	100	-	-	-
75	100	100	0,88	91	245	315	250	226	315	250	140	200	160	135	200	160	106	160	125	82	125	100
90	125	125	0,88	92	292	400	315	268	315	315	170	250	200	165	200	200	128	160	160	98	125	125
110	150	150	0,88	92	358	500	400	327	400	400	205	250	250	200	250	250	156	200	200	118	160	125
129	175	175	0,88	92	420	500	500	384	500	400	242	315	250	230	315	250	184	250	200	-	-	-
132	180	-	0,88	92	425	500	500	393	500	500	245	315	250	-	-	-	186	250	200	140	200	160
147	200	200	0,88	93	472	630	630	432	630	500	273	315	315	260	315	315	207	250	250	-	-	-
160	220	-	0,88	93	502	630	630	471	630	630	295	400	315	-	-	-	220	315	250	170	200	200
184	250	250	0,88	93	590	800	630	541	630	630	340	400	400	325	400	400	259	315	315	-	-	-
200	270	-	0,88	93	626	800	800	589	800	630	370	500	400	-	-	-	278	315	315	215	250	250
220	300	300	0,88	93	700	1000	800	647	800	800	408	500	500	385	500	400	310	400	400	-	-	-
250	340	-	0,88	93	803	1000	1000	736	1000	800	460	630	500	-	-	-	353	500	400	268	315	315
257	350	350	0,88	93	826	1000	1000	756	1000	800	475	630	630	450	630	500	363	500	400	-	-	-
295	400	400	0,88	93	948	1250	1000	868	1000	1000	546	800	630	500	630	630	416	500	500	-	-	-
315	430	-	0,88	93	990	1250	1250	927	1250	1000	580	800	630	-	-	-	445	630	500	337	400	400
355	483	-	0,89	95	-	-	-	-	-	-	636	800	800	-	-	-	483	630	630	366	500	400
400	545	-	0,89	96	-	-	-	-	-	-	710	1000	800	-	-	-	538	630	630	410	500	500

The motor F.L.C. be valid for standard internal and surface cooled three-pole motors with 1500 min⁻¹. The fuses values be valid for the motor F.L.C. shown in the table and D.O.L.-start: starting current max. 6x motor F.L.C., starting time max. 5s; star-delta-start: starting current max. 2x motor F.L.C., starting time max. 15s. For

motors with higher F.L.C., higher starting current and/or longer starting time, larger short-circuit fuses are required. The maximum admissible value is dependent on the switchgear respectively thermal overload relay.

Approximate values of motor F.L.C. according to CSA and UL

Motor rating hp	Motor F.L.C. at 110-120V			Motor F.L.C. at 220-240V ¹⁾			Motor F.L.C. at 440-480V			Motor F.L.C. at 550-600V		
	1-phase A	2-phase A	3-phase A	1-phase A	2-phase A	3-phase A	1-phase A	2-phase A	3-phase A	1-phase A	2-phase A	3-phase A
1/2	9.8	4.0	4.4	4.9	2.0	2.2	2.5	1.0	1.1	2.0	0.8	0.9
3/4	13.8	4.8	6.4	6.9	2.4	3.2	3.5	1.2	1.6	2.8	1.0	1.3
1	16.0	6.4	8.4	8.0	3.2	4.2	4.0	1.6	2.1	3.2	1.3	1.7
1-1/2	20.0	9.0	12.0	10.0	4.5	6.0	5.0	2.3	3.0	4.0	1.8	2.4
2	24.0	11.8	13.6	12.0	5.9	6.8	6.0	3.0	3.4	4.8	2.4	2.7
3	34.0	16.6	19.2	17.0	8.3	9.6	8.5	4.2	4.8	6.8	3.3	3.9
5	56.0	26.4	30.4	28.0	13.2	15.2	14.0	6.6	7.6	11.2	5.3	6.1
7-1/2	80.0	38.0	44.0	40.0	19.0	22.0	21.0	9.0	11.0	16.0	8.0	9.0
10	100.0	48.0	56.0	50.0	24.0	28.0	26.0	12.0	14.0	20.0	10.0	11.0
15	135.0	72.0	84.0	68.0	36.0	42.0	34.0	18.0	21.0	27.0	14.0	17.0
20	-	94.0	108.0	88.0	47.0	54.0	44.0	23.0	27.0	35.0	19.0	22.0
25	-	118.0	136.0	110.0								

Contactors

Data according to IEC 947-4-1, EN 60947-4-1, VDE 0660

Main Contacts	Type	K(G)3-10	K(G)3-14	K(G)3-18	K(G)3-22	K(G)3-24	K(G)3-32	K(G)3-40	K3-50	K3-62	K3-74
Rated insulation voltage U_i ¹⁾	V AC	690	690	690	690	690	690	690	690	690	690
Making capacity I_{eff} at $U_e = 690V$ AC	A	200	200	200	200	400	500	500	700	900	900
Breaking capacity I_{eff} 400V AC	A	180	180	200	200	380	400	400	600	800	800
K2-09 to K3-22 $\cos\phi = 0,65$ 500V AC	A	150	150	180	180	300	370	370	500	700	700
K3-24 to K3-1200 $\cos\phi = 0,35$ 690V AC	A	100	100	150	150	260	340	340	400	500	500
1000V AC	A	-	-	-	-	-	-	-	-	-	-
Utilization category AC1											
Switching of resistive load											
Rated operational current $I_e (=I_{th})$ at 40°C, open	690V A	25	25	32	32	50	65	80	110	120	130
Rated operational power of three-phase resistive loads 50-60Hz, $\cos\phi = 1$	220V kW	9,5	9,5	12,2	12,2	19,0	24,7	30,4	41,9	45,7	49,5
	230V kW	9,9	9,9	12,7	12,7	19,9	25,9	31,8	43,8	47,7	51,7
	240V kW	10,4	10,4	13,3	13,3	20,8	27,0	33,2	45,7	49,8	54,0
	380V kW	16,4	16,4	21,0	21,0	32,9	42,7	52,6	72,3	78,9	85,5
	400V kW	17,3	17,3	22,1	22,1	34,6	45,0	55,4	76,1	83,0	90,0
	415V kW	17,9	17,9	23,0	23,0	35,9	46,7	57,4	79,0	86,2	93,3
	440V kW	19,0	19,0	24,4	24,4	38,1	49,5	60,9	83,7	91,3	99,0
	500V kW	21,6	21,6	27,7	27,7	43,3	56,2	69,2	95,2	103,8	112,5
	660V kW	28,5	28,5	36,5	36,5	57,1	74,2	91,3	125,6	137,0	148,4
	690V kW	29,8	29,8	38,2	38,2	59,7	77,6	95,5	131,3	143,2	155,2
	1000V kW	-	-	-	-	-	-	-	-	-	-
Rated operational current $I_e (=I_{the})$ at 60°C, enclosed	690V A	25	25	32	32	40	55	65	90	100	110
Rated operational power of three-phase resistive loads 50-60Hz, $\cos\phi = 1$	220V kW	9,5	9,5	12,2	12,2	15,2	20,9	24,7	34,3	38,1	41,9
	230V kW	9,9	9,9	12,7	12,7	15,9	21,9	25,9	35,8	39,8	43,8
	240V kW	10,4	10,4	13,3	13,3	16,6	22,8	27,0	37,4	41,5	45,7
	380V kW	16,4	16,4	21,0	21,0	26,3	36,2	42,7	59,2	65,7	72,3
	400V kW	17,3	17,3	22,1	22,1	27,7	38,1	45,0	62,3	69,2	76,1
	415V kW	17,9	17,9	23,0	23,0	28,7	39,5	46,7	64,6	71,8	79,0
	440V kW	19,0	19,0	24,4	24,4	30,4	41,9	49,5	68,5	76,1	83,7
	500V kW	21,6	21,6	27,7	27,7	34,6	47,6	56,2	77,9	86,5	95,2
	660V kW	28,5	28,5	36,5	36,5	45,7	62,8	74,2	102,8	114,2	125,6
	690V kW	29,8	29,8	38,2	38,2	47,7	65,7	77,6	107,4	119,4	131,3
	1000V kW	-	-	-	-	-	-	-	-	-	-
Minimum cross-section of conductor at load with $I_e (=I_{th})$	mm ²	4	4	6	6	10	16	25	35	50	50
Utilization category AC2 and AC3											
Switching of three-phase motors											
Rated operational current I_e open and enclosed	220V A	12	15	18	22	24	30	40	50	63	74
	230V A	11,5	14,5	18	22	24	30	40	50	62	74
	240V A	11	14	18	22	24	32	40	50	62	74
	380-400V A	10	14	18	22	24	32	40	50	62	74
	415V A	9	14	18	22	23	30	40	50	62	74
	440V A	9	14	18	22	23	30	40	50	62	74
	500V A	7	9	9	9	17,5	21	21	33	42	42
	660-690V A	6,5	8,5	8,5	8,5	17	20	20	31	40	40
	1000V A	-	-	-	-	-	-	-	-	-	-
Rated operational power of three-phase motors 50-60Hz	220-230V kW	3	4	5	6	6	8,5	11	12,5	18,5	22
	240V kW	3	4	5	7	7	9	11,5	13,5	19	23
	380-400V kW	4	5,5	7,5	11	11	15	18,5	22	30	37
	415V kW	4,5	6	8,5	12	12	16	20	24	33	40
	440V kW	4,5	6	8,5	12	12	16	20	24	33	40
	500V kW	5,5	7,5	10	10	15	18,5	18,5	30	37	45
	660-690V kW	5,5	7,5	10	10	15	18,5	18,5	30	37	45
	1000V kW	-	-	-	-	-	-	-	-	-	-

1) Suitable at 690V for: earthed-neutral systems, overvoltage category I to IV, pollution degree 3 (standard-industry): $U_{imp} = 8kV$.
Data for other conditions on request.

Contactors

Data according to IEC 947-4-1, EN 60947-4-1, VDE 0660

Type	K3-90	K3-115	K3-151	K3-176	K3-210	K3-260	K3-316	K3-450	K3-550	K3-700	K3-860	K3-1000	K3-1200
V~	1000	1000	1000	1000	1000	1000	1000	1000	1000	690	690	690	690
A	1100	1200	1500	2000	2100	2600	3200	4500	5500	7000	8600	10000	12000
A	950	1100	1200	1500	1600	2100	2600	4500	5500	7000	8000	8000	10000
A	850	1000	1200	1500	1600	2100	2600	4500	5500	7000	8000	8000	10000
A	600	600	1000	800	1200	1900	2300	3200	4400	5600	6900	7000	8000
A	-	-	500	600	700	850	1000	-	-	-	-	-	-
A	160	200	230	250	350	450	500	700	760	1000	1100	1200	1350
kW	60	76	87	95	133	171	190	266	289	381	419	457	514
kW	63	79	91	99	139	179	199	279	302	398	438	478	537
kW	66	83	95	103	145	187	207	291	315	415	457	498	561
kW	105	131	151	164	230	296	329	460	500	658	724	789	888
kW	110	138	159	173	242	311	346	485	526	692	762	831	935
kW	115	143	165	179	251	323	359	503	546	718	790	862	970
kW	121	152	175	190	266	342	381	533	579	762	838	914	1028
kW	138	173	199	216	303	389	453	606	658	866	952	1039	1169
kW	182	228	262	285	400	514	571	800	868	1143	1257	1371	1543
kW	191	239	274	298	418	537	597	836	908	1195	1314	1434	1613
kW	221	277	318	346	433	546	606	692	866	-	-	-	-
A	145	170	180	200	280	360	400	550	600	800	875	960	1080
kW	55	64	68	76	106	137	152	209	228	304	333	365	411
kW	57	67	71	79	111	143	159	219	239	318	348	382	430
kW	59	70	74	83	116	150	166	228	249	332	363	399	448
kW	95	111	118	131	184	237	263	362	395	526	575	631	710
kW	100	117	124	138	193	249	277	381	415	554	606	665	748
kW	104	122	129	143	201	259	287	395	431	575	628	690	776
kW	110	129	137	152	213	274	304	419	457	609	666	731	823
kW	125	147	155	173	242	312	346	476	519	692	757	831	935
kW	165	194	205	228	320	412	457	628	685	914	1000	1097	1234
kW	173	202	215	239	334	430	478	657	717	956	1045	1147	1290
kW	166	187	277	346	388	499	554	692	866	-	-	-	-
mm ²	95	120	95	120	240	2x150	2x(30x6)	2x(40x5)	2x(50x5)	2x(60x5)	2x(60x6)	2x(60x6)	2x(60x8)
A	90	115	150	175	210	260	315	450	550	700	860	1000	1200
A	90	115	150	175	210	260	315	450	550	700	860	1000	1200
A	90	115	150	175	210	260	315	450	550	700	860	1000	1200
A	90	115	150	175	210	260	315	450	550	700	860	1000	1200
A	90	115	150	175	210	260	315	450	550	700	860	1000	1200
A	90	115	150	175	210	260	315	450	550	700	860	1000	1200
A	60	60	150	175	210	260	315	450	550	700	860	1000	1200
A	58	58	120	140	150	180	240	400	500	630	700	860	1000
A	58	58	60	70	85	100	125	200	250	-	-	-	-
kW	25	33	40	50	60	75	90	132	175	225	280	325	390
kW	27	35	45	55	65	80	100	140	185	235	290	335	400
kW	45	55	75	90	110	132	160	250	300	400	500	580	680
kW	49	63	80	95	115	140	180	257	315	415	515	600	710
kW	49	63	85	100	125	150	190	270	335	450	530	630	750
kW	55	55	90	100	132	160	210	300	375	500	600	720	850
kW	55	55	110	132	160	210	250	375	500	630	700	850	1000
kW	55	55	75	90	110	132	160	280	355	-	-	-	-

Contactors

Data according to IEC 947-4-1, EN 60947-4-1, VDE 0660

Main Contacts	Type	K(G)3-10	K(G)3-14	K(G)3-18	K(G)3-22	K(G)3-24	K(G)3-32	K(G)3-40	K3-50	K3-62	K3-74
Utilization category AC4											
Switching of squirrel cage motors, inching											
Rated operational current I_e open and enclosed	220V A	12	15	18	18	24	30	40	50	63	63
	230V A	11,5	14,5	18	18	24	30	40	50	62	62
	240V A	11	14	18	18	24	32	40	50	62	62
	380-400V A	10	14	18	18	24	32	40	50	62	62
	415V A	9	14	18	18	23	30	37	45	60	60
	440V A	9	14	18	18	23	30	37	45	55	55
	500V A	9	12	16	16	17,5	21	21	33	42	42
	660V A	7	9	9	9	17	20	20	31	40	40
	690V A	6,5	8,5	8,5	8,5	17	20	20	31	40	40
	1000V A	-	-	-	-	-	-	-	-	-	-
Rated operational power of three-phase motors 50-60Hz	220-230V kW	3	4	5	5	6	8,5	11	12,5	18,5	18,5
	240V kW	3	4	5	5	7	9	11,5	13,5	19	19
	380-400V kW	4	5,5	7,5	7,5	11	15	18,5	22	30	30
	415V kW	4,5	6	8,5	8,5	12	16	20	24	33	33
	440V kW	4,5	6	8,5	8,5	12	16	20	24	33	33
	500V kW	5,5	7,5	10	10	15	18,5	18,5	30	37	37
	660-690V kW	5,5	7,5	10	10	15	18,5	18,5	30	37	37
	1000V kW	-	-	-	-	-	-	-	-	-	-
Utilization category AC5a											
Switching of gas discharge lamps											
Rated operational current I_e per pole at 220/230V											
Fluorescent lamps, uncompensated and serial compensated parallel compensated dual-connection	A	20	20	25	25	40	52	64	88	96	104
	A	7	9	9	9	18	22	22	30	40	45
	A	22,5	22,5	28	28	45	58	72	98	108	117
Metal halide lamps ¹⁾ , uncompensated parallel compensated	A	12	15	19	19	30	39	48	66	72	78
	A	7	9	9	9	18	22	22	30	40	45
Mercury-vapour lamps ²⁾ , uncompensated parallel compensated	A	22,5	25	28	28	45	58	72	99	108	117
	A	7	9	9	9	18	22	22	30	40	45
Mixed light lamps ³⁾	A	20	20	25	25	40	52	64	88	96	104
Utilization category AC5b											
Switching of incandescent lamps⁴⁾											
Rated operational current I_e per pole at 220/230V											
	A	12,5	12,5	12,5	12,5	25	31	31	43	56	56

1) Metal halide lamps and sodium-vapour lamps (high- and low-pressure lamps)

2) High-pressure lamps

3) Blended lamps, containing a mercury high-pressure unit and a tungsten helix in a fluorescent glass bulb (daylight lamps)

4) Current inrush approx. 16 x I_e

Contactors

Data according to IEC 947-4-1, EN 60947-4-1, VDE 0660

Type	K3-90	K3-115	K3-151	K3-176	K3-210	K3-260	K3-316	K3-450	K3-550	K3-700	K3-860	K3-1000	K3-1200
A	85	98	55	63	85	100	120	150	180	230	280	340	400
A	85	98	55	63	85	100	120	150	180	230	280	340	400
A	85	98	55	63	85	100	120	150	180	230	280	340	400
A	85	85	55	63	85	100	120	150	180	230	280	340	400
A	85	85	55	63	85	100	120	150	180	230	280	340	400
A	85	85	55	63	85	100	120	150	180	230	280	340	400
A	85	85	-	-	-	-	-	-	-	-	-	-	-
A	60	60	-	-	-	-	-	-	-	-	-	-	-
A	57,5	57,5	-	-	-	-	-	-	-	-	-	-	-
A	-	-	-	-	-	-	-	-	-	-	-	-	-
kW	25	30	15	18,5	25	30	37	45	51	68	80	110	132
kW	27	32	15,5	19	26	31	38	47	53	71	83	115	137
kW	45	45	25	30	45	55	63	75	90	120	150	185	220
kW	49	49	25	33	45	55	65	80	100	132	160	200	230
kW	49	49	30	34	48	55	67	85	100	132	160	200	230
kW	55	55	25	30	55	65	75	100	110	150	185	220	257
kW	55	55	25	30	55	65	75	100	110	150	185	220	257
kW	-	-	-	-	-	-	-	-	-	-	-	-	-
A	100	120	120	140	180	220	280	360	450	570	700	850	1000
A	55	70	85	100	130	160	200	300	360	460	550	660	800
A	112	144	120	140	180	220	280	360	450	570	700	850	1000
A	85	90	95	110	140	180	230	300	380	490	610	750	890
A	55	70	75	85	110	140	170	260	300	400	480	580	700
A	112	144	120	140	180	220	280	360	450	570	700	850	1000
A	55	70	75	85	110	140	170	260	300	400	480	580	700
A	100	120	100	120	160	200	250	320	400	500	600	700	800
A	69	75	100	120	160	190	220	260	315	440	500	560	630

Contactors

Data according to IEC 947-4-1, EN 60947-4-1, VDE 0660

Main Contacts		Type	K(G)3-10	K(G)3-14	K(G)3-18	K(G)3-22	K(G)3-24	K(G)3-32	K(G)3-40	K3-50	K3-62	K3-74
Utilization category AC6a												
Transformer primary switching												
at inrush		n	30	30	30	30	30	30	30	30	30	30
Rated operational current I_e	400V	A	4,5	5,5	7,5	7,5	10,5	13,5	13,5	20	27	33
Rated operational power	220-230V	kVA	1,8	2,2	3	3	4,2	5,4	5,4	8	10,7	13
dependent on inrush n	240V	kVA	1,9	2,3	3,1	3,1	4,3	5,6	5,6	8,3	11,2	13,5
	380-400V	kVA	3,1	3,8	5,2	5,2	7,3	9,3	9,3	13,5	18,5	22,5
For different inrush-factors x	415-440V	kVA	3,4	4,2	5,7	5,7	8	10,2	10,2	15	20,5	25
use the following formula:	500V	kVA	3,9	4,8	6,5	6,5	9	11,5	11,5	17	23	28
$P_x = P_n \cdot (n/x)$	660-690V	kVA	5,4	6,5	9	9	12,5	16	16	24	32	39
Utilization category AC6b												
Switching of three-phase capacitors												
Maximum inrush current (peak value)												
as multiple k of the												
capacitor rated current												
		k	35	25	20	20	25	25	25	25	25	20
Rated operational current I_e	500V	A	8	12	15,5	15,5	23	32	32	45	60	70
Rated operational power	220-230V	kVAr	3	4,5	6	6	8,5	12	12	17	24	28
($\sin\phi \rightarrow 1$)	240V	kVAr	3,5	5	6,5	6,5	9,5	13	13	18,5	25	29
	380-400V	kVAr	5	7,5	10	10	15	20	20	29	39	46
For different multiples x	415-440V	kVAr	5,5	8	11	11	16	22	22	32	43	50
use the following formula:	500V	kVAr	7	10	13	13	20	26	26	39	50	58
$P_x = P_k \cdot (k/x)$	660-690V	kVAr	7	10	13	13	20	26	26	40	50	58
Switching of reactive capacitor banks												
Rated operational current I_e	690V	A	8	13	18	20	28	36	42	48	72	108 ¹⁾
Rated operational power	220-230V	kVAr	2,9	5	7	7,5	11	14	16	20	28	33
	240V	kVAr	3,1	5,4	7	8	11	14	17	20	28	36
	380-400V	kVAr	5	9	12,5	13	20	25	27,5	33,3	50	75 ¹⁾
	415-440V	kVAr	5,5	9,5	13	14	22	27	30	36	53	75 ¹⁾
	500V	kVAr	6	11	15	17	25	30	36	40	60	75
	660-690V	kVAr	8	15	20	22	33	41	48	55	82	100
	1000V	kVAr	-	-	-	-	-	-	-	-	-	-
Utilization category DC1												
Switching of resistive load												
Time constant $L/R \leq 1\text{ms}$												
Rated operational current I_e	1 pole	24V A	20	25	32	32	50	65	80	110	120	130
		60V A	20	25	32	32	50	65	80	110	120	130
		110V A	6	6	6	6	10	10	10	12	12	12
		220V A	0,8	0,8	0,8	0,8	1,4	1,4	1,4	1,4	1,4	1,4
	3 poles in series	24V A	20	25	32	32	50	65	80	110	120	130
		60V A	20	25	32	32	50	65	80	110	120	130
		110V A	20	25	32	32	50	65	80	110	120	130
		220V A	16	20	20	20	30	35	35	63	80	80
Utilization category DC3 and DC5												
Switching of shunt motors and series motors												
Time constant $L/R \leq 15\text{ms}$												
Rated operational current I_e	1 pole	24V A	20	25	32	32	50	65	80	110	120	130
		60V A	6	6	6	6	30	30	30	60	60	60
		110V A	1,2	1,2	1,2	1,2	1,8	1,8	1,8	1,8	1,8	1,8
		220V A	0,2	0,2	0,2	0,2	0,2	0,2	0,2	0,25	0,25	0,25
	3 poles in series	24V A	20	25	32	32	50	65	80	110	120	130
		60V A	20	25	32	32	40	40	40	80	80	80
		110V A	20	20	20	20	40	40	40	80	80	80
		220V A	2,5	2,5	2,5	2,5	4	4	4	5	5	5

1) Consider resistive load (I_{th}). see page 44



Contactors

Data according to IEC 947-4-1, EN 60947-4-1, VDE 0660

Type	K3-90	K3-115	K3-151	K3-176	K3-210	K3-260	K3-316	K3-450	K3-550	K3-700	K3-860	K3-1000	K3-1200
n	30	30	30	30	30	30	30	30	30	30	30	30	30
A	38	50	65	80	90	120	142	203	248	315	390	450	540
kVA	15	20	25	30	34	45	54	77	95	120	148	170	200
kVA	15,5	20,5	27	33	37	50	59	80	100	130	160	185	220
kVA	26	34	45	55	60	80	95	140	170	210	270	310	370
kVA	29	38	46	57	63	85	100	145	175	220	280	320	380
kVA	33	43	55	69	75	100	120	170	210	270	330	380	460
kVA	45	60	56	69	100	135	160	200	250	320	350	500	600
k	20	20	20	20	25	20	20	20	20	20	20	20	20
A	87	100	120	155	195	225	255	300	370	440	520	680	760
kVAr	33	38	45	60	75	90	100	115	145	170	200	260	290
kVAr	36	42	52	62	78	94	104	120	150	175	205	270	300
kVAr	57	65	80	100	130	155	170	200	250	300	350	450	500
kVAr	60	70	95	110	135	165	175	210	260	310	360	465	520
kVAr	70	80	100	130	170	194	220	260	320	380	450	590	660
kVAr	70	80	100	130	170	194	220	260	320	380	450	590	660
A	115	144	115	140	200	225	250	330	420	550	600	680	760
kVAr	45	55	43	53	76	85	95	125	160	209	228	260	290
kVAr	45	55	45	55	80	90	100	130	170	220	240	280	310
kVAr	80	100	75	90	130	145	160	210	270	350	390	440	480
kVAr	100	120	80	100	140	160	170	230	290	380	420	470	530
kVAr	105	125	95	120	170	190	210	280	350	450	500	570	640
kVAr	120	148	125	150	200	230	260	350	450	600	650	700	800
kVAr	160	200	155	200	300	340	400	500	650	-	-	-	-
A	160	200	-	-	-	-	-	-	-	-	-	-	-
A	160	200	-	-	-	-	-	-	-	-	-	-	-
A	20	25	-	-	-	-	-	-	-	-	-	-	-
A	2	2,5	-	-	-	-	-	-	-	-	-	-	-
A	160	200	200	250	350	400	450	600	760	1000	1100	1200	1350
A	160	200	200	250	350	400	450	600	760	1000	1100	1200	1350
A	160	200	150	170	250	280	315	400	480	560	630	800	900
A	100	160	80	100	150	180	200	250	315	400	450	500	600
A	160	200	-	-	-	-	-	-	-	-	-	-	-
A	85	110	-	-	-	-	-	-	-	-	-	-	-
A	2	2,5	-	-	-	-	-	-	-	-	-	-	-
A	0,5	0,5	-	-	-	-	-	-	-	-	-	-	-
A	160	200	-	-	-	-	-	-	-	-	-	-	-
A	100	110	-	-	-	-	-	-	-	-	-	-	-
A	100	110	-	-	-	-	-	-	-	-	-	-	-
A	7	8	-	-	-	-	-	-	-	-	-	-	-

Contactors



Data according to IEC 947-4-1, EN 60947-4-1, VDE 0660

Main Contacts			Type	K(G)3-10	K(G)3-14	K(G)3-18	K(G)3-22	K(G)3-24	K(G)3-32	K(G)3-40	K3-50	K3-62	K3-74
Maximum ambient temperature													
Operation	open	°C						-40 to +60 (+90) ¹⁾					
	enclosed	°C						-40 to +40					
with thermal overload relay	open	°C						-25 to +60					
	enclosed	°C						-25 to +40					
Storage		°C						-50 to +90					
Short circuit protection													
for contactors without thermal overload relay													
Coordination-type "1" according to IEC 947-4-1													
Contact welding without hazard of persons													
max. fuse size	gL (gG)	A		63	63	63	63	80	80	80	160	160	160
Coordination-type "2" according to IEC 947-4-1													
Light contact welding accepted													
max. fuse size	gL (gG)	A		25	35	35	35	50	50	50	100	125	125
Contact welding not accepted													
max. fuse size	gL (gG)	A		16	16	16	16	25	35	35	50	63	63
For contactors with thermal overload relay the device with the smaller admissible backup fuse (contactor or thermal overload relay) determines the fuse size.													
Cable cross-sections													
for contactors without thermal overload relay													
1 cable per clamp													
main connector	solid or stranded	mm ²			0,75 - 6					1,5 - 25			4 - 50
	flexible	mm ²			1 - 4					2,5 - 16			10 - 35
	flexible with multicore cable end	mm ²			0,75 - 4					1,5 - 16			6 - 35
2 cables per clamp													
	solid or stranded	mm ²			6+(1-6) / 4+(0,75-4)			16+(2,5-16) / 10+(4-16)			50+4 / 35+6 / 25+(6-16)		
	flexible	mm ²			2,5+(0,75-2,5) / 1,5+(0,75-1,5)			6+(4-16) / 4+(2,5-16)			16+(6-16) / 10+(6-16)		
					6+(1,5-4) / 4+(1-4)			16+(2,5-6) / 10+(4-10)			50+(4-10) / 35+(4-16)		
					2,5+(0,75-2,5) / 1,5+(0,75-1,5)			6+(4-16) / 4+(2,5-16)			25+(4-25) / 16+(4-16)		
1 cable per clamp													
main connector	solid	AWG			18 - 10					16 - 10			12 - 10
	flexible	AWG			18 - 10					14 - 4			10 - 0
2 cables per clamp													
	solid	AWG			10+(16-10) / 12+(18-12)			10+(16-10) / 12+(18-12)					10+(12-10) / 12+12
					14+(18-14) / 16+(18-16)			14+(18-14) / 16+(18-16)					
	flexible	AWG			10+(14-10) / 12+(18-12)			4+(18-12) / 6+(18-8)					1+(12-10) / 2+(8-12)
					14+(18-14) / 16+(18-16)			8+(18-8) / 10+(18-12)					3+(12-8) / 4+(10-6)
Frequency of operations z													
Contactors without thermal overload relay													
	without load	1/h			10000					7000			7000
	AC3, I _e	1/h			600					600			400
	AC4, I _e	1/h			120					120			120
	DC3, I _e	1/h			600					600			400
Mechanical life													
AC operated	S x 10 ⁶				10					10			10
DC operated	S x 10 ⁶				10					10			10
DC-solenoid operated (KG3)	S x 10 ⁶				50					50			-
Short time current													
	10s-current	A		96	120	144	176	184	240	296	360	504	592
	120s-current	A		28	35	42	51	53	69	85	104	145	171
Power loss per pole													
contact resistance	at I _e /AC3 400V	W		0,21	0,35	0,5	0,75	0,7	1,3	2	2,2	3,9	5,5
		mOhm		2,1	1,8	1,5	1,5	1,2	1,2	1,2	1	1	1
Resistance to shock acc. to IEC 68-2-27													
Shock time 20ms sine-wave	NO	g		10	10	10	10	8	8	8	8	8	8
	NC	g		6	6	6	6	-	-	-	-	-	-

1) With reduced control voltage range 0,9 up to 1,0 x U_s and with reduced rated current I_e/AC1 according to I_e/AC3

Contactors

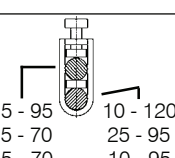
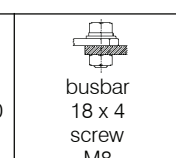
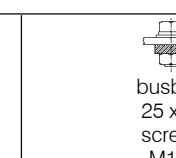
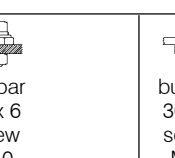
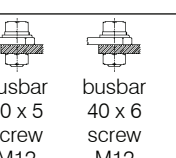
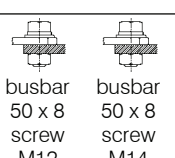
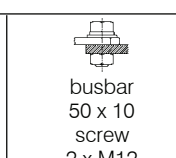
Data according to IEC 947-4-1, EN 60947-4-1, VDE 0660

Type	K3-90	K3-115	K3-151	K3-176	K3-210	K3-260	K3-316	K3-450	K3-550	K3-700	K3-860	K3-1000	K3-1200	
°C	-40 to +60 (+90) ¹⁾								-25 to +55 (+70) ²⁾					
°C	-40 to +40								-25 to +40					
°C	-25 to +60								-25 to +55					
°C	-25 to +40								-25 to +40					
°C	-50 to +90								-55 to +80					
A	250	250	250	315	400	450	500	630	630	800	1000	1000	1250	
A	160	200	200	250	315	400	400	500	560	-	-	-	-	
A	100	125	160	200	250	315		-	-	-	-	-	-	
mm ² mm ² mm ²	 0,5 - 95 0,5 - 70 0,5 - 70	 10 - 120 25 - 95 10 - 95	 busbar 18 x 4 screw M8	 busbar 25 x 6 screw M10	 busbar 30 x 5 screw M12	 busbar 40 x 6 screw M12	 busbar 50 x 8 screw M12	 busbar 50 x 8 screw M14	 busbar 50 x 10 screw 2 x M12					
mm ² mm ² mm ²	0,5 - 95 + 10 - 120 0,5 - 70 + 25 - 95													
AWG AWG	18 - 10 18 - 3/0	- 8 - 4/0												
AWG AWG	- 18 - 3/0 + 8 - 4/0													
1/h 1/h 1/h 1/h	3000 300 120 300		1200 - - -		1200 - - -			1200 - - -				300 - - -		
S x 10 ⁶ S x 10 ⁶ S x 10 ⁶	5 5 -		10 10 -		5 5 -			5 5 -				5 ³⁾ 5 ³⁾ -		
A A	680 196	880 254	1200 346	1400 404	1800 520	2200 751	2600 900	3600 1039	4400 1270	5600 1617	6900 1992	8000 2309	9600 2771	
W mOhm	4,8 0,6	7,9 0,5	9 0,4	11 0,35	8 0,18	11 0,16	14,9 0,15	26,3	33,3	49	59,2	60	72	
g g g	7 5	7 5	- -	- -	- -	- -	- -	- -	- -	- -	- -	- -	- -	

1) With reduced control voltage range 0,9 up to 1,0 x U_s and with reduced rated current I_b/AC1 according to I_b/AC3

2) With reduced control voltage range 1,0 x U_s and with reduced rated current I_b/AC1 according to I_b/AC3

3) After each 1x10⁶ operations magnetic core and built-in auxiliary contact block must be changed

Contactors

Data according to IEC 947-4-1, EN 60947-4-1, VDE 0660

Auxiliary Contacts			Type	K(G)3-10	K(G)3-14	K(G)3-18	K(G)3-22	K(G)3-24	K(G)3-32	K(G)3-40	K3-50	K3-62	K3-74
Rated insulation voltage U_i ¹⁾			V~	690				-		-			
Thermal rated current I_{th} to 690V													
Ambient temperature			40°C	A	10	(16) ⁵⁾			-			-	
			60°C	A	6	(12) ⁵⁾			-			-	
Utilization category AC15													
Rated operational current I_e			220-240V	A	3	(12) ⁵⁾			-			-	
			380-415V	A	2	(4) ⁵⁾			-			-	
			440V	A	1,6	(4) ⁵⁾			-			-	
			500V	A	1,2	(3) ⁵⁾			-			-	
			660-690V	A	0,6	(1) ⁵⁾			-			-	
Utilization category DC13													
Rated operational current I_e			60V	A	3,5	(8) ⁵⁾			-			-	
			110V	A	0,5	(1) ⁵⁾			-			-	
			220V	A	0,1				-			-	
Short circuit protection short-circuit current 1kA, contact welding not accepted max. fuse size			gL (gG)	A	25				-		-		
Control Circuit													
Power consumption of coils													
AC operated			inrush	VA	33-45				90-115		140-165		
			sealed	VA	7-10				9-13		13-18		
				W	2,6-3				2,7-4		5,4-7		
DC operated			inrush	W	75				140		200		
double winding coil			sealed	W	2				2		6		
DC solenoid operated (KG3)			inrush	W	3				4		-		
			sealed	W	3				4		-		
Operation range of coils in multiples of control voltage U_s													
			AC operated		0,85-1,1				0,85-1,1		0,85-1,1		
			DC operated		0,8-1,1				0,8-1,1		0,8-1,1		
Switching time at control voltage $U_s \pm 10\%$ ^{2) 3)}													
AC operated			make time	ms	8-16				10-25		12-28		
			release time	ms	5-13				8-15		8-15		
			arc duration	ms	10-15				10-15		10-15		
DC operated			make time	ms	8-12				10-20		12-23		
double winding coil			release time	ms	8-13				10-15		10-18		
			arc duration	ms	10-15				10-15		10-15		
DC solenoid operated (KG3)			make time	ms	65 - 85				65 - 85		-		
			release time	ms	20 - 30 ⁴⁾				20 - 30 ⁴⁾		-		
			arc duration	ms	10-15				10-15		-		
Cable cross-section													
Auxiliary connector			solid	mm ²	0,75-6				-		-		
			flexible	mm ²	1-4				-		-		
			flexible with multicore cable end	mm ²	0,75-4				-		-		
Magnet coil			solid	mm ²	0,75-2,5				0,75-2,5		0,75-2,5		
			flexible	mm ²	0,5-2,5				0,5-2,5		0,5-2,5		
			flexible with multicore cable end	mm ²	0,5-1,5				0,5-1,5		0,5-1,5		
Clamps per pole					2				2		2		
Auxiliary connector			solid	AWG	18 - 10				-		-		
			flexible	AWG	18 - 10				-		-		
Magnet coil			solid	AWG	14 - 12				14 - 12		14 - 12		
			flexible	AWG	18 - 12				18 - 12		18 - 12		
Clamps per pole					2				2		2		

1) Suitable for: earthed-neutral systems, overvoltage category I to IV, pollution degree 3 (standard-industry): $U_{imp} = 8kV$. Data for other conditions on request

2) Total breaking time = release time + arc duration

3) Values for delay of the release time of the make contact and the make time of the break contact will be increased, if magnet coils are protected against voltage peaks (varistor, RC-unit, diode-unit)

4) with built-in coil suppressor 5) for contactors KG3-..A.. only

Contactors

Data according to IEC 947-4-1, EN 60947-4-1, VDE 0660

Type	K3-90	K3-115	K3-151	K3-176	K3-210	K3-260	K3-316	K3-450	K3-550	K3-700	K3-860	K3-1000	K3-1200
V~	-	-	-	-	-	-	-	690	-	690	-	690	-
A	-	-	-	-	-	-	-	10	-	10	-	10	-
A	-	-	-	-	-	-	-	-	-	-	-	-	-
-	-	-	-	-	-	-	-	-	-	-	-	-	-
A	-	-	-	-	-	-	-	3	-	3	-	3	-
A	-	-	-	-	-	-	-	2	-	2	-	2	-
A	-	-	-	-	-	-	-	1,5	-	1,5	-	1,5	-
A	-	-	-	-	-	-	-	1,5	-	1,5	-	1,5	-
A	-	-	-	-	-	-	-	1	-	1	-	1	-
A	-	-	-	-	-	-	-	-	-	-	-	-	-
A	-	-	-	-	-	-	-	1	-	1	-	1	-
A	-	-	-	-	-	-	-	0,5	-	0,5	-	0,5	-
A	-	-	-	-	-	-	-	-	-	-	-	-	-
A	-	-	-	-	-	-	-	10	-	10	-	10	-
VA	165-220	-	350	-	360	-	-	800-950	-	1350-1600	-	2400	-
VA	2,5-5	-	5	-	5	-	-	9-11	-	21-25	-	70	-
W	2,5-5	-	5	-	5	-	-	9-11	-	21-25	-	70	-
W	250	-	350	-	360	-	-	700-850	-	1300-1550	-	2100	-
W	5	-	5	-	5	-	-	8-10	-	18-22	-	60	-
W	-	-	-	-	-	-	-	-	-	-	-	-	-
W	-	-	-	-	-	-	-	-	-	-	-	-	-
ms	0,85-1,1 0,8-1,1	-	0,85-1,1 0,85-1,1	-	0,85-1,1 0,85-1,1	-	-	0,85-1,1 0,85-1,1	-	0,85-1,1 0,85-1,1	-	0,85-1,1 0,85-1,1	-
ms	20-35	-	30-60	-	40-60	-	-	50-100	-	50-100	-	50-100	-
ms	60-70	-	30-80	-	15-45	-	-	150-200 / 500-1000 ¹⁾	-	25-50	-	25-50	-
ms	10-15	-	-	-	-	-	-	-	-	-	-	-	-
ms	20-35	-	30-60	-	40-60	-	-	-	-	-	-	-	-
ms	60-70	-	30-80	-	15-45	-	-	-	-	-	-	-	-
ms	10-15	-	-	-	-	-	-	-	-	-	-	-	-
ms	-	-	-	-	-	-	-	-	-	-	-	-	-
ms	-	-	-	-	-	-	-	-	-	-	-	-	-
ms	-	-	-	-	-	-	-	-	-	-	-	-	-
mm ²	-	-	-	-	-	-	-	0,75-2,5	-	0,75-2,5	-	0,75-2,5	-
mm ²	-	-	-	-	-	-	-	0,75-2,5	-	0,75-2,5	-	0,75-2,5	-
mm ²	-	-	-	-	-	-	-	-	-	-	-	-	-
mm ²	0,75-2,5	-	1-2,5	-	1-2,5	-	-	1-2,5	-	1-2,5	-	1-2,5	-
mm ²	0,5-2,5	-	1-2,5	-	1-2,5	-	-	1-2,5	-	1-2,5	-	1-2,5	-
mm ²	0,5-1,5	-	-	-	-	-	-	-	-	-	-	-	-
mm ²	2	-	2	-	2	-	-	2	-	2	-	2	-
AWG	-	-	-	-	-	-	-	16 - 12	-	16 - 12	-	16 - 12	-
AWG	-	-	-	-	-	-	-	16 - 12	-	16 - 12	-	16 - 12	-
AWG	14 - 12	-	16 - 12	-	16 - 12	-	-	16 - 12	-	16 - 12	-	16 - 12	-
AWG	18 - 12	-	16 - 12	-	16 - 12	-	-	16 - 12	-	16 - 12	-	16 - 12	-
AWG	2	-	2	-	2	-	-	2	-	2	-	2	-

1) Normal or delayed drop is adjustable

Contactors

Data according to IEC 947-4-1, EN 60947-4-1, VDE 0660

Main Contacts	Type	K2-09	K2-12	K2-16	K2-23	K2-30	K2-37	K2-45	K2-60	K85	K110
Rated insulation voltage $U_i^{(1)}$	V~	690	690	690	690	690	690	690	690	750	750
Making capacity I_{eff} at $U_e = 690V$ AC	A	200	200	200	400	500	500	700	900	1100	1200
Breaking capacity I_{eff}	400V~ A	180	180	200	380	400	400	600	800	950	1100
	K2-09 to K2-16 $\cos\phi = 0,65$ 500V AC A	150	150	180	300	370	370	500	700	850	1100
	K2-23 to K3-1200 $\cos\phi = 0,35$ 690V AC A	100	100	150	260	340	340	400	500	600	600
	1000V~ A	-	-	-	-	-	-	-	-	-	-
Utilization category AC1											
Switching of resistive load											
Rated operational current $I_e (=I_{th})$ at 40°C, open	A	25	25	25	45	50	50	80	100	150	170
Rated operational power of three-phase resistive loads 50-60Hz, $\cos\phi = 1$	220V kW	9,5	9,5	9,5	17	19	19	30	38	57	64
	230V kW	10	10	10	18	20	20	31,5	40	59	67
	240V kW	10,5	10,5	10,5	18,5	20,5	20,5	33	41	62	70
	380V kW	16,5	16,5	16,5	29,5	33	33	52	65	98	111
	400V kW	17,5	17,5	17,5	31	34,5	34,5	55	69	103	117
	415V kW	18	18	18	32	36	36	57	71	107	122
	440V kW	19	19	19	34	38	38	61	76	114	129
	500V kW	21,5	21,5	21,5	39	43	43	69	86	130	147
	660V kW	28,5	28,5	28,5	51	57	57	91	114	171	194
	690V kW	29,5	29,5	29,5	53,5	60	60	95	119	179	203
Rated operational current $I_e (=I_{the})$ at 60°C, enclosed	A	20	25	25	35	40	40	63	80	100	125
Rated operational power of three-phase resistive loads 50-60Hz, $\cos\phi = 1$	220V kW	7,5	9,5	9,5	13	15	15	24	30	38	47
	230V kW	8	10	10	13,5	16	16	25	31,5	40	49
	240V kW	8	10,5	10,5	14,5	16,5	16,5	26	33	41	52
	380V kW	13	16,5	16,5	23	26	26	41	52	65	82
	400V kW	13,5	17,5	17,5	24	27,5	27,5	43	55	69	86
	415V kW	14	18	18	25	28,5	28,5	45	57	71	89
	440V kW	15	19	19	26,5	30	30	48	61	71	95
	500V kW	17	21,5	21,5	30	34	34	54	69	86	116
	660V kW	22,5	28,5	28,5	40	45	45	72	91	114	142
	690V kW	23,5	29,5	29,5	42	48	48	75	95	119	149
Minimum cross-section of conductor at load with $I_e (=I_{th})$	mm ²	4	4	4	10	10	10	25	35	50	70
Utilization category AC2 and AC3											
Switching of three-phase motors											
Rated operational current I_e open and enclosed	220V A	12	15	18	23	30	37	45	63	85	110
	230V A	11,5	14,5	17,5	23	30	37	45	61	85	110
	240V A	11	14	17	23	30	37	45	60	85	110
	380-400V A	10	12	16	23	30	37	45	60	85	110
	415-440V A	9	12	16	23	30	37	45	60	85	110
	500V A	9	12	16	23	30	30	45	55	85	110
	660V A	7	9	9	17,5	21	21	33	42	60	60
	690V A	6,5	8,5	8,5	17	20	20	31	40	58	58
Rated operational power of three-phase motors 50-60Hz	220-230V kW	3	4	5	6	8,5	11	12,5	18,5	25	33
	240V kW	3	4	5	7	9	11,5	13,5	19	27	35
	380-400V kW	4	5,5	7,5	11	15	18,5	22	30	45	55
	415V kW	4,5	6	8,5	12	16	20	24	33	49	63
	440V kW	4,5	6	8,5	12	16	20	24	33	49	63
	500V kW	5,5	7,5	10	15	18,5	18,5	30	37	55	55
	660-690V kW	5,5	7,5	7,5	15	18,5	18,5	30	37	55	55

1) Suitable at 690V for: earthed-neutral systems, overvoltage category I to IV, pollution degree 3 (standard-industry): $U_{imp} = 8kV$.
Data for other conditions on request.

Contactors

Data according to IEC 947-4-1, EN 60947-4-1, VDE 0660

Main Contacts	Type	K2-09	K2-12	K2-16	K2-23	K2-30	K2-37	K2-45	K2-60	K85	K110
Utilization category AC4											
Switching of squirrel cage motors, inching											
Rated operational current I_e	220V A	12	15	16	23	30	37	45	63	85	98
open and enclosed	230V A	11,5	14,5	16	23	30	37	45	61	85	98
	240V A	11	14	16	23	30	37	45	60	85	98
	380-400V A	10	12	16	23	30	37	45	60	85	85
	415V A	9	12	16	21	28	37	45	60	85	85
	440V A	9	12	16	21	28	37	45	60	85	85
	500V A	9	12	16	17	23	23	45	55	85	85
	660V A	7	9	9	13	17	17	33	42	60	60
	690V A	6,5	8,5	8,5	12,5	16,5	16,5	31	40	57,5	57,5
Rated operational power of three-phase motors 50-60Hz	220-230V kW	3	4	5	6	8,5	11	12,5	18,5	25	30
	240V kW	3	4	5	7	9	11,5	13,5	19	27	32
	380-400V kW	4	5,5	7,5	11	15	18,5	22	30	45	45
	415-440V kW	4,5	6	8,5	11	15	20	24	33	49	49
	500V kW	5,5	7,5	10	11	15	15	30	37	55	55
	660-690V kW	5,5	7,5	7,5	11	15	15	30	37	55	55
Utilization category AC5a											
Switching of gas discharge lamps											
Rated operational current I_e per pole at 220/230V											
Fluorescent lamps, uncompensated	A	20	20	20	35	40	40	65	85	100	120
Fluorescent lamps, compensated	A	7	9	9	18	22	22	30	40	55	70
Fluorescent lamps, dual-connection	A	22,5	22,5	22,5	41	45	45	72	90	112	144
Metal-halide lamps ¹⁾ , uncompensated	A	12	15	15	28	30	30	50	62	85	90
Metal-halide lamps ¹⁾ , compensated	A	7	9	9	18	22	22	30	40	55	70
Mercury-vapour lamps ²⁾ , uncompensated	A	22,5	25	25	41	45	45	72	90	112	144
Mercury-vapour lamps ²⁾ , compensated	A	7	9	9	18	22	22	30	40	55	70
Mixed light lamps ³⁾	A	20	20	20	35	40	40	65	85	100	120
Utilization category AC5b											
Switching of incandescent lamps⁴⁾											
Rated operational current I_e per pole at 220/230V											
	A	12,5	12,5	12,5	25	31	31	43	56	69	75
Utilization category AC6a											
Transformer primary switching											
at inrush											
Rated operational current I_e	400V n	30	30	30	30	30	30	30	30	30	30
	A	4,5	5,5	7,5	10,5	13,5	13,5	20	27	38	50
Rated operational power dependent on inrush n	220-230V kVA	1,8	2,2	3	4,2	5,4	5,4	8	10,7	15	20
	240V kVA	1,9	2,3	3,1	4,3	5,6	5,6	8,3	11,2	15,5	20,5
	380-400V kVA	3,1	3,8	5,2	7,3	9,3	9,3	13,5	18,5	26	34
For different inrush-factors x use the following formula: $P_x = P_n * (n/x)$	415-440V kVA	3,4	4,2	5,7	8	10,2	10,2	15	20,5	29	38
	500V kVA	3,9	4,8	6,5	9	11,5	11,5	17	23	33	43
	660-690V kVA	5,4	6,5	9	12,5	16	16	24	32	45	60
Utilization category DC1											
Switching of resistive load											
Time constant $L/R \leq 1ms$											
Rated operational current I_e	1 pole 24V A	20	25	25	45	50	50	80	100	150	170
	60V A	20	25	25	45	50	50	80	100	150	170
	110V A	6	6	6	10	10	10	12	12	20	25
	220V A	0,8	0,8	0,8	1,4	1,4	1,4	1,4	1,4	2	2,5
	3 poles in series 24V A	20	25	25	45	50	50	80	100	150	170
	60V A	20	25	25	45	50	50	80	100	150	170
	110V A	20	25	25	45	50	50	80	100	150	170
	220V A	16	20	20	30	35	35	63	80	100	160

1) Metal halide lamps and sodium-vapour lamps (high- and low-pressure lamps)

2) High-pressure lamps

3) Blended lamps, containing a mercury high-pressure unit and a tungsten helix in a fluorescent glass bulb (daylight lamps)

4) Current inrush approx. $16 \times I_e$

5) With central compensation pay attention to the current inrush (capacitor switching contactors)

Contactors

Data according to IEC 947-4-1, EN 60947-4-1, VDE 0660

Main Contacts	Type	K2-09	K2-12	K2-16	K2-23	K2-30	K2-37	K2-45	K2-60	K85	K110	
Utilization category DC3 and DC5												
Switching of shunt motors and series motors												
Time constant L/R ≤ 15ms												
Rated operational current I _e	1 pole	24V A	20	25	25	45	50	50	80	100	150	170
		60V A	6	6	6	30	30	30	60	60	85	110
		110V A	1,2	1,2	1,2	1,8	1,8	1,8	1,8	1,8	2	2,5
		220V A	0,2	0,2	0,2	0,2	0,2	0,2	0,25	0,25	0,5	0,5
3 poles in series	24V A	20	25	25	45	50	50	80	100	150	170	
		60V A	20	25	25	40	40	40	80	80	100	110
		110V A	20	20	20	40	40	40	80	80	100	110
		220V A	2,5	2,5	2,5	4	4	4	5	5	7	8
Maximum ambient temperature												
Operation	open	°C		-40 to +60 (+90) ¹⁾								
	enclosed	°C		-40 to +40								
with thermal overload relay	open	°C		-25 to +60								
	enclosed	°C		-25 to +40								
Storage	°C		-50 to +90									
Short circuit protection												
for contactors without thermal overload relay												
Coordination-type "1" according to IEC 947-4-1												
Contact welding without hazard of persons												
max. fuse size	gL (gG)	A	63	63	63	80	80	80	160	160	250	250
Coordination-type "2" according to IEC 947-4-1												
Light contact welding accepted												
max. fuse size	gL (gG)	A	25	35	35	50	50	50	100	125	160	200
Contact welding not accepted												
max. fuse size	gL (gG)	A	16	16	16	25	35	35	50	63	100	125
For contactors with thermal overload relay the device with the smaller admissible backup fuse (contactor or thermal overload relay) determines the fuse size.												
Cable cross-sections												
for contactors without thermal overload relay												
main connector	solid or stranded	mm ²	0,75 - 4			1,5-10 + 1,5-6			4 - 35 ²⁾		10 - 70 ²⁾	
		flexible	0,75 - 2,5			1,5-6 + 1,5-4			6 - 25 ²⁾		10 - 70 ²⁾	
flexible with multicore cable end		mm ²	0,5 - 2,5			1,5-6 + 1,5-4			4 - 25		10 - 35	
		Cables per clamp	2			1+1			1		1	
main connector	solid	AWG	14 - 10			14 - 10 + 14 - 10			10		10	
		flexible	18 - 10			14 - 8 + 14 - 10			10 - 2		6 - 0	
Cables per clamp			2			1+1			1		1	
Frequency of operations z												
Contactors without thermal overload relay												
	without load	1/h	10000			7000			7000		3000	
	AC3, I _e	1/h	600			600			400		300	
	AC4, I _e	1/h	120			120			120		120	
	DC3, I _e	1/h	600			600			400		300	
Mechanical life												
AC operated		S x 10 ⁶	10			10			10		5	
DC operated with economy resistor		S x 10 ⁶	10			10			10		5	
Short time current												
	10s-current	A	96	120	144	184	240	296	360	504	680	880
Power loss per pole												
	at I _e /AC3 400V	W	0,21	0,26	0,4	0,63	1,1	1,7	1,8	3,6	4,3	6,0
Resistance to shock acc. to IEC 68-2-27												
Shock time 20ms sine-wave	NO	g	10	10	10	8	8	8	8	8	7	7
	NC	g	6	6	6	5	5	5	-	-	5	5

1) With reduced control voltage range 0,9 up to 1,0 x U_s and with reduced rated current I_e/AC1 according to I_e/AC3

2) Maximum cable cross-section with prepared conductor

Contactors

Data according to IEC 947-4-1, EN 60947-4-1, VDE 0660

Auxiliary Contacts	Type	K2-09	K2-12	K2-16	K2-23	K2-30	K2-37	K2-45	K2-60	K85	K110
Rated insulation voltage U_i ¹⁾	V AC		690			690		-			690
Thermal rated current I_{th} to 690V											
Ambient temperature	40°C A		16			16		-			16
	60°C A		12			12		-			12
Utilization category AC15											
Rated operational current I_e	220-240V A		12			12		-			12
	380-415V A		4			4		-			6
	440V A		4			4		-			6
	500V A		3			3		-			4
	660-690V A		1			1		-			2
Utilization category DC13											
Rated operational current I_e	60V A		8			8		-			8
	110V A		1			1		-			1
	220V A		0,1			0,1		-			0,1
Short circuit protection short-circuit current 1kA, contact welding not accepted max. fuse size gL (gG) A For contactors with thermal overload relay the device with the smaller admissible control fuse (contactor or thermal overload relay) determines the fuse.			25			-		-			25
Control Circuit											
Power consumption of coils											
AC operated	inrush VA		33-45			90-115		140-165		280-350	350-420
	sealed VA		7-10			9-13		13-18		16-23	23-29
	W		2,6-3			2,7-4		5,4-7		4-6	6-7,3
DC operated	inrush W		75			140		200		170	320
with economic circuit	sealed W		2			2		6		2	4
Operation range of coils in multiples of control voltage U_s											
	AC operated		0,85-1,1			0,85-1,1		0,85-1,1		0,85-1,1	0,85-1,1
	DC operated		0,8-1,1			0,8-1,1		0,8-1,1		0,8-1,1	0,8-1,1
Switching time at control voltage $U_s \pm 10\%$ ^{2) 3)}											
AC operated	make time ms		8-16			10-25		12-28		13-30	13-30
	release time ms		5-13			8-15		8-15		8-15	8-15
	arc duration ms		10-15			10-15		10-15		10-15	10-15
DC operated	make time ms		8-12			10-20		12-23		20-30	20-30
with AC magnet system	release time ms		8-13			10-15		10-18		10-18	10-18
	arc duration ms		10-15			10-15		10-15		10-15	10-15
Cable cross-section											
Auxiliary connector	solid mm ²		0,75-4			-		-		0,75-2,5	0,75-2,5
	flexible mm ²		0,75-2,5			-		-		0,75-2,5	0,75-2,5
	flexible with multicore cable end mm ²		0,5-2,5			-		-		0,5-1,5	0,5-1,5
Magnet coil	solid mm ²		0,75-2,5			0,75-2,5		0,75-2,5		0,75-2,5	0,75-2,5
	flexible mm ²		0,5-2,5			0,5-2,5		0,5-2,5		0,5-2,5	0,5-2,5
	flexible with multicore cable end mm ²		0,5-1,5			0,5-1,5		0,5-1,5		0,5-1,5	0,5-1,5
Clamps per pole			2			2		2		2	2

1) Suitable for: earthed-neutral systems, overvoltage category I to IV, pollution degree 3 (standard-industry): $U_{imp} = 8kV$. Data for other conditions on request

2) Total breaking time = release time + arc duration

3) Values for delay of the release time of the make contact and the make time of the break contact will be increased, if magnet coils are protected against voltage peaks (varistor, RC-unit, diode-unit)

Contactors for North America

Data according to UL508

Main Contacts (cULus)		Type	K(G)3-10	K(G)3-14	K(G)3-18	K(G)3-22	K(G)3-24	K(G)3-32	K(G)3-40	K3-50	K3-62	K3-74
Rated operational current "General Use"		A	25	25	30	30	50	65	80	110	120	130
Motor DOL 3-phase at 60Hz												
Rated operational current		600V A	10	14	18	22	22	27	34	44	52	66
Rated operational power		110-120V hp	1½	2	2	3	5	5	7½	10	10	10
		200V hp	3	3	5	5	7½	10	10	15	20	25
		220-240V hp	3	3	7½	7½	10	10	15	20	25	30
		277V hp	3	5	7½	7½	7½	10	15	20	25	30
		380-415V hp	5	5	10	10	10	15	20	25	30	40
		440-480V hp	5	7½	10	15	15	20	25	30	40	50
		550-600V hp	7½	10	15	20	20	25	30	40	50	50
Motor DOL 1-phase at 60Hz												
Rated operational current		600V A	10	14	18	22	22	27	34	44	52	66
Rated operational power of AC motors at 60Hz (1ph)		110-120V hp	½	¾	1	1½	1½	2	3	3	5	7½
		200V hp	1	1,5	2	3	3	5	7½	7½	10	15
		220-240V hp	1½	2	3	3	5	5	7½	10	15	15
		277V hp	2	3	3	5	5	7½	10	10	15	15
		380-415V hp	3	3	5	5	5	7½	10	15	20	20
		440-480V hp	3	5	5	7½	7½	10	15	20	25	25
		550-600V hp	3	5	7½	10	10	15	20	25	30	30
Motor DOL 3-phase according to ANSI A17.5												
Rated operational current		600V A	-	-	-	-	15	22	-	27	37	-
Rated operational power of 3-phase motors for elevators (500.000 operations)		110-120V hp	-	-	-	-	2	3	-	3	5	-
		200V hp	-	-	-	-	3	5	-	7½	10	-
		220-240V hp	-	-	-	-	5	7½	-	7½	10	-
		440-480V hp	-	-	-	-	10	15	-	20	25	-
		550-600V hp	-	-	-	-	10	20	-	25	30	-
Rated current 2 series contacts		600V A	-	-	-	-	22	27	-	44	52	66
Fuse Class RK5 / Short-circuit current		A/kA	50/5	50/5	70/5	90/5	90/5	125/5	175/5	200/5	250/5	300/5
Fuse Class T / Short-circuit current Rated voltage		A/kA V	45/100 600	50/100 600	70/100 600	90/100 600	110/100 600	150/100 600	150/100 600	175/100 600	175/100 600	175/100 600
Auxiliary Contacts (cULus)			A600	A600	A600	A600	-	-	-	-	-	-

Main Contacts (cULus)		Type	K2-09	K2-12	K2-16	K2-23	K2-30	K2-45	K2-60	K85	K110
Rated operational current "General Use"		A	25	25	25	40	40	72	90	125	150
Motor DOL 3-phase at 60Hz											
Rated operational power		110-120V hp	1½	2	2	3	5	-	-	15	-
		200V hp	2	3	3	5	7½	10	15	-	30
		220-240V hp	3	3	5	7½	10	15	20	35	40
		440-480V hp	5	7½	10	15	20	30	40	65	75
		550-600V hp	7½	10	15	20	25	40	50	85	100
Motor DOL 1-phase at 60Hz											
Rated operational power		110-120V hp	½	¾	1	1½	2	3	5	8	10
		200V hp	1	2	2	3	3	5	7½	-	20
		220-240V hp	1½	2	3	3	5	7½	10	20	20
Fuse / Short-circuit current		A/kA	30/5	40/5	50/5	60/5	110/5	175/5	175/5	-	300/5
Rated voltage		V	600	600	600	600	600	600	600	600	600
Auxiliary Contacts (cULus)			A600	A600	A600	A600	A600	-	-	A600	A600

Contactors for North America

Data according to UL508

Type	K3-90	K3-115	K3-151	K3-176	K3-210	K3-260	K3-316	K3-450	K3-550	K3-700	K3-860	K3-1000	K3-1200
A	160	200	180	220	250	300	350	420	520	700	810	-	1215
A	85	99	125	150	190	240	300	300	400	550	700	-	1000
hp	15	20	-	-	-	-	-	-	-	-	-	-	-
hp	25	35	40	50	60	75	100	125	150	200	250	-	450
hp	35	40	50	60	75	100	125	125	150	250	300	-	450
hp	-	-	-	-	-	-	-	-	-	-	-	-	-
hp	50	60	-	-	-	-	-	-	-	-	-	-	-
hp	65	75	100	125	150	200	250	250	350	500	600	-	900
hp	85	100	125	150	200	250	300	250	350	500	600	-	900
A	86	103	125	150	-	-	-	-	-	-	-	-	-
hp	8	10	15	25	-	-	-	-	-	-	-	-	-
hp	15	20	-	-	-	-	-	-	-	-	-	-	-
hp	20	25	25	30	40	50	50	-	-	-	-	-	-
hp	20	25	-	-	-	-	-	-	-	-	-	-	-
hp	30	40	-	-	-	-	-	-	-	-	-	-	-
hp	40	50	-	-	-	-	-	-	-	-	-	-	-
hp	50	60	-	-	-	-	-	-	-	-	-	-	-
A	-	-	-	-	-	-	-	-	-	-	-	-	-
hp	-	-	-	-	-	-	-	-	-	-	-	-	-
hp	-	-	-	-	-	-	-	-	-	-	-	-	-
hp	-	-	-	-	-	-	-	-	-	-	-	-	-
hp	-	-	-	-	-	-	-	-	-	-	-	-	-
A	-	-	-	-	-	-	-	-	-	-	-	-	-
A/kA	300/10	300/10	300/10	350/10	400/18	500/18	500/18	1200/18	1200/18	2000/30	2000/30	-	2000/42
A/kA	300/100 ³⁾	300/100 ³⁾	-	-	-	-	-	-	-	-	-	-	-
V	600	600	600	600	600	600	600	600	600	600	600	-	600
	-	-	-	-	-	-	-	A600	A600	A600	A600	-	A600

Main Contacts (cULus)	Type	K3-18NK	K3-24K	K3-32K	K3-50K	K3-62K	K3-74K	K3-90K	K3-115K
Rated operational power of 3-phase capacitor banks at 60Hz (3ph)	110-120V kVAr	0-3,5	3-5,5	3-7	6,5-10	6,5-15	6,5-18 ¹⁾	10-24	10-28 ²⁾
	200V kVAr	0-6	4,5-10	4,5-12,5	10-16,7	10-25	10-32 ¹⁾	17-40	17-46 ²⁾
	220-240V kVAr	0-7	5,5-11	5,5-15	12,5-20	12,5-30	12,5-36 ¹⁾	20-47	20-56 ²⁾
	440-480V kVAr	0-15	11,5-25	11,5-30	25-40	25-60	25-72 ¹⁾	40-95	40-114 ²⁾
	550-600V kVAr	0-18	14,5-30	14,5-35	31-50	31-75	31-90 ¹⁾	50-120	50-143 ²⁾
Fuse Class RK5 / Short-circuit current	A/kA	70/5	90/5	125/5	200/5	250/5	300/5	300/10	300/10
Fuse Class T / Short-circuit current	A/kA	80/100	110/100	150/100	175/100	175/100	175/100	300/100 ³⁾	300/100 ³⁾
Rated voltage	V	600	600	600	600	600	600	600	600
Auxiliary Contacts (cULus)		A600	-	-	-	-	-	-	-

1) Consider the max. thermal current of the contactor K3-74A: I_{th} 130A

2) Consider the min. cross-section of conductor at max. load

3) Class T and Class RK1

Contactors

Data according to IEC 947-4-1, EN 60947-4-1, VDE 0660

Contact Life

For selection of the suitable contactor-type according to supply voltage, power rating and application (utilization category AC1, AC3 or AC4) use contact life characteristic diagram.

For the most common supply voltages four scales of power ratings P_n are provided for each utilization category.

Select contactor-type according to utilization category **AC3** (breaking current $I_a = I_n$) using the **motor rating** scales to the right, according to utilization category **AC4** (breaking current $I_a = 6 \times I_n$) using the **motor rating** scales to the left. ¹⁾

Select contactor-type according to utilization category **AC1** (breaking current $I_a = I_n/AC1$) using the **breaking current** scale. ¹⁾

For contactors frequently used under AC3/AC4-mixed service conditions calculate contact life with the formula:

$$M = \frac{AC3}{1 + \frac{\%AC4}{100} \times \left(\frac{AC3}{AC4} - 1 \right)}$$

M = Contact life (switching cycles) for AC3/AC4-mixed operations
 AC3 = Contact life (switching cycles) for AC3 operations (normal switching conditions).
 Breaking current I_a = rated motor current I_n .
 AC4 = Contact life (switching cycles) for AC4 operations (inching).
 Breaking current I_a = multiples of rated motor current I_n .
 %AC4 = Percents of AC4-operations related to the total cycles.

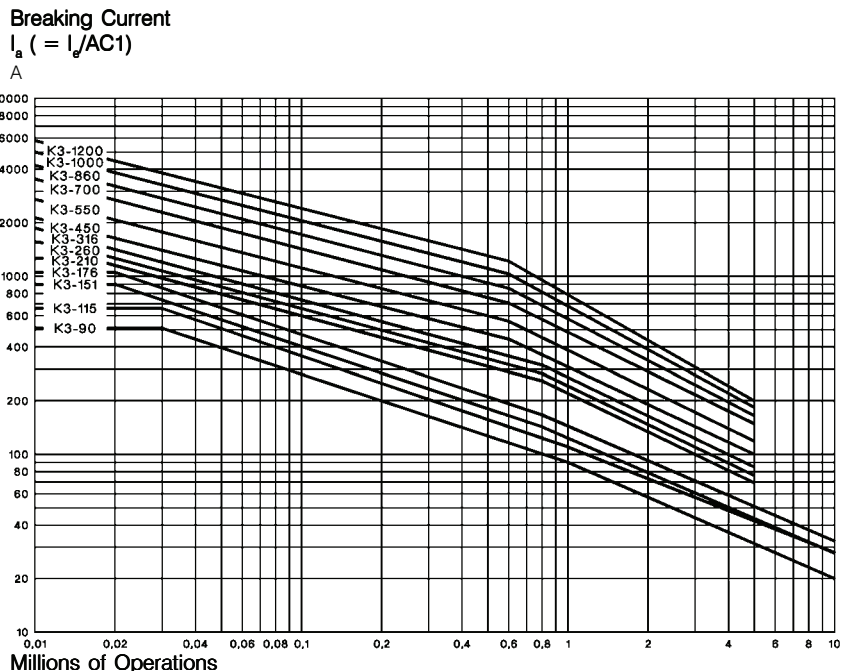
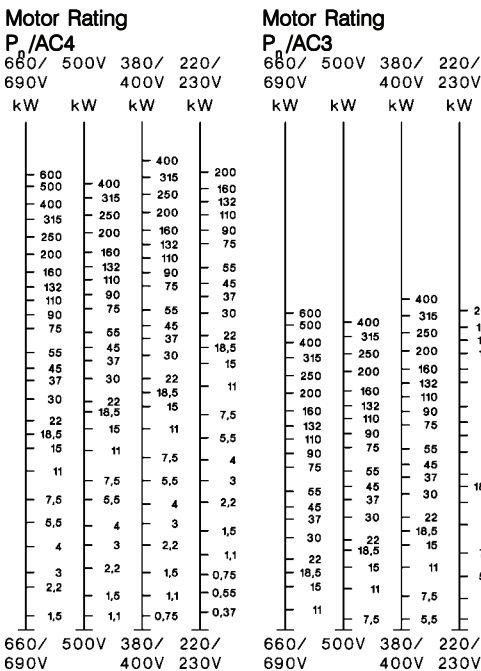
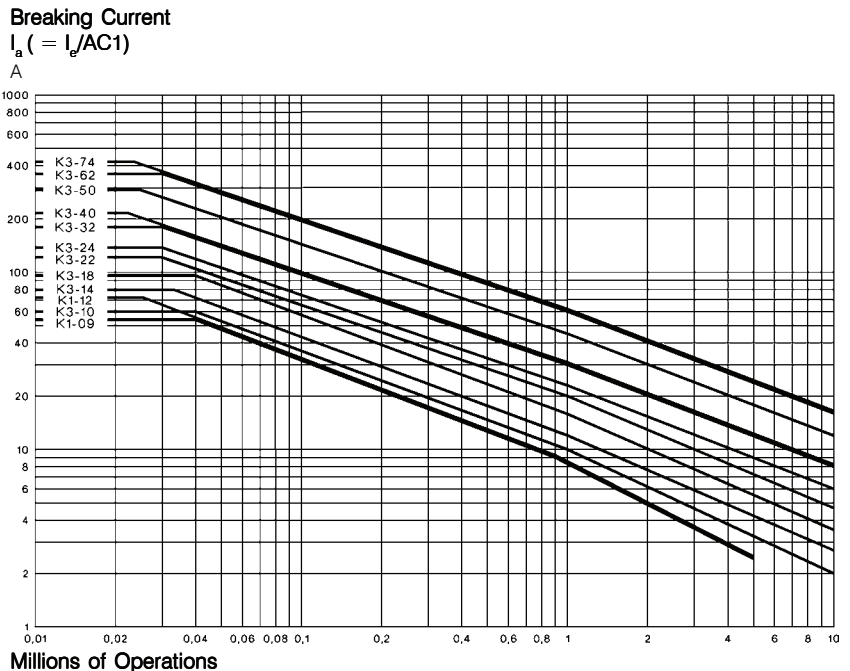
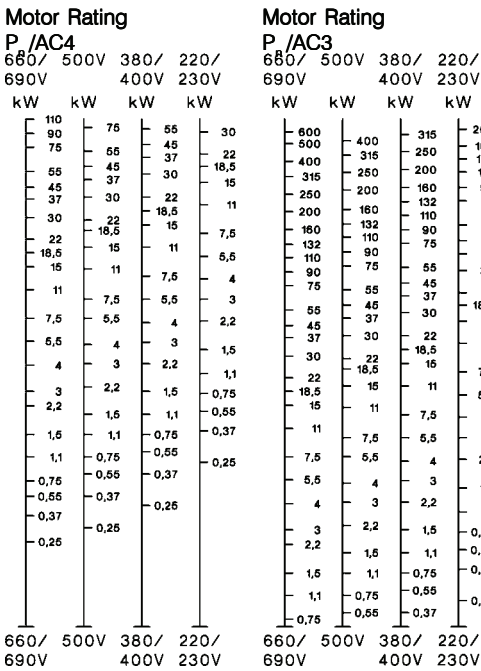

1) Pay attention to the approved rated values of the selected contactor according to the national approvals

Contactors

Utilization Categories

For easier choice of devices and in order to make the comparison of different products simpler are utilization categories for contactors and motor-starters according to IEC 947-4-1 and VDE 0660 Part 102, for

control circuit devices and switching elements according to IEC 947-5-1 and VDE 0660 Part 200 determined. The table offers different utilization categories, typical applications and assorted test conditions.

Type of current	Category	Typical applications	Rated operational current	Test conditions for the number of on-load operating cycles						Test conditions for making and breaking capacities					
				Make			Break			Make			Break		
				I_e/I_e	U/U_e	$\cos\phi$	I_e/I_e	U/U_e	$\cos\phi$	I_e/I_e	U/U_e	$\cos\phi$	I_e/I_e	U/U_e	$\cos\phi$
Alternating Current	AC1	Non-inductive or slightly inductive loads resistance furnaces	all values	1	1	0,95	1	1	0,95	1,5	1,05	0,8	1,5	1,05	0,8
	AC2	Slip-ring motors: starting, switching off	all values	2,5	1	0,65	2,5	1	0,65	4	1,05	0,65	4	1,05	0,65
	AC3	Squirrel-cage motors: starting, switching off motors during running	17A < I_e/I_e < 17A > 100A < I_e/I_e > 100A	6	1	0,65	1	0,17	0,65	10	1,05	0,45	8	1,05	0,45
				6	1	0,35	1	0,17	0,35	10	1,05	0,45	8	1,05	0,45
				6	1	0,35	1	0,17	0,35	10	1,05	0,35	8	1,05	0,35
	AC4	Squirrel-cage motors: starting, plugging, inching	17A < I_e/I_e < 17A > 100A < I_e/I_e > 100A	6	1	0,65	6	1	0,65	12	1,05	0,45	10	1,05	0,45
				6	1	0,35	6	1	0,35	12	1,05	0,45	10	1,05	0,45
				6	1	0,35	6	1	0,35	12	1,05	0,35	10	1,05	0,35
	AC5a	Switching of electric discharge lamp controls	all values	-	-	-	-	-	-	3	1,05	0,45	3	1,05	0,45
	AC5b	Switching of incandescent lamps	all values	-	-	-	-	-	-	1,5	1,05	1)	4	1,05	1)
	AC6a	Switching of transformers	I_e/I_e < 100A < I_e/I_e > 100A	-	-	-	-	-	-	4,5	1,05	0,45	3,6	1,05	0,45
				-	-	-	-	-	-	4,5	1,05	0,35	3,6	1,05	0,35
	AC6b	Switching of capacitors	-	-	-	-	-	-	-	2)			2)		
	AC7a	Slightly inductive loads in household appliances and similar applications	all values	-	-	-	-	-	-	1,5	1,05	0,8	1,5	1,05	0,8
	AC7b	Motor loads for household applications	I_e/I_e < 100A < I_e/I_e > 100A	-	-	-	-	-	-	8	1,05	0,45	6	1,05	0,45
-				-	-	-	-	-	8	1,05	0,35	6	1,05	0,35	
AC8a	Hermetic refrigerant compressor motor control with manual resetting of overload releases	I_e/I_e < 100A < I_e/I_e > 100A	-	-	-	-	-	-	6	1,05	0,45	6	1,05	0,45	
			-	-	-	-	-	-	6	1,05	0,35	6	1,05	0,35	
AC8b	Hermetic refrigerant compressor motor control with automatic resetting of overload releases	I_e/I_e < 100A < I_e/I_e > 100A	-	-	-	-	-	-	6	1,05	0,45	6	1,05	0,45	
			-	-	-	-	-	-	6	1,05	0,35	6	1,05	0,35	
AC12	Control of resistive loads and solid state loads with isolation by opto couplers	all values	-	-	-	-	-	-	1	1	0,9	1	1	0,9	
AC13	Control of solid state loads with transformer isolation	all values	-	-	-	-	-	-	10	1,1	0,65	1,1	1,1	0,65	
AC14	Control of small electromagnetic loads ($\leq 72VA$)	-	-	-	-	-	-	-	6	1,1	0,7	6	1,1	0,7	
AC15	Control of electromagnetic load ($> 72VA$)	-	10	1	0,7	1	1	0,4	10	1,1	0,3	10	1,1	0,3	
Direct Current				Make I_e/I_e	U/U_e	L/R [ms]	Break I_e/I_e	U/U_e	L/R [ms]	Make I_e/I_e	U/U_e	L/R [ms]	Break I_e/I_e	U/U_e	L/R [ms]
	DC1	Non-inductive or slightly inductive loads resistance furnaces	all values	1	1	1	1	1	1	1,5	1,05	1	1,5	1,05	1
	DC3	Shunt-motors: starting, plugging, inching dynamic braking of d.c. motors	all values	2,5	1	2	2,5	1	2	4	1,05	2,5	4	1,05	2,5
	DC5	Series-motors: starting, plugging, inching dynamic braking of d.c. motors	all values	2,5	1	7,5	2,5	1	7,5	4	1,05	15	4	1,05	15
	DC6	Switching of incandescent lamps	all values	-	-	-	-	-	-	1,5	1,05	1)	4	1,05	1)
	DC12	Control of resistive loads and solid state loads with isolation by opto couplers	all values	-	-	-	-	-	-	1	1	1	1	1	1
	DC13	Control of electromagnets	all values	1	1	≤ 300	1	1	≤ 300	1,1	1,1	≤ 300	1,1	1,1	≤ 300
DC14	Control of electromagnetic loads having economy resistors in circuit	all values	-	-	-	-	-	-	10	1,1	15	10	1,1	15	

U_e Rated operational voltage, U Voltage before make, U_r Recovery voltage, I_e Rated operational current, I_c Current make, I_b Current broken

1) Test with incandescent lamps

2) Test conditions according to standard

Accessories

Data according to IEC 947-4-1, EN 60947-4-1, VDE 0660

Type		HN	HTN	HA	HB	HKT HKA	HKF HKB	K2-DK K2-SK	K2-TP	K2-L ²⁾
Rated insulation voltage U_i ¹⁾	V AC	690	690	690	690	690	690	690	690	690
Thermal rated current I_{th} to 690V										
Ambient temperature	max. 40°C	A	10	10	25	10	16	26	10	10
	max. 60°C	A	6	6	20	-	-	-	-	6
Frequency of operations z	1/h	3000	-	3000	3000	-	-	-	1200	3000
Mechanical life	S x 10 ⁶	10	10	10	10	-	-	-	1	10
Power loss per pole at $I_e/AC1$	W	0,5	0,5	1,5	0,5	-	-	-		
Utilization category AC15										
Rated operational current I_e	220-240V	A	3	3	6	3	3	-	4	3
	380-400V	A	2	2	3	2	2	-	3	2
	440V	A	1,6	1,6	2	1,5	1,5	-	2	1,6
	500V	A	1,2	1,2	2	1,5	1,5	-	2	1
	660-690V	A	0,6	0,6	1	1	1	-	2	0,5
Utilization category DC13										
Rated operational current I_e	60V	A	2	2	8	2	-	-	2,5	2
	110V	A	0,4	0,4	1	0,4	0,5	0,5	1,5	0,4
	220V	A	0,1	0,1	0,1	0,1	0,2	0,2	0,2	0,1
Short circuit protection short-circuit current 1kA, contact welding not accepted max. fuse size	gL (gG)	A	20	20	25	20	10	10	-	10
For contactors with thermal overload relay or auxiliary contacts the device with the smaller admissible control fuse (contactor or thermal overload relay) determines the fuse size.										
Cable cross-sections										
	solid or stranded	mm ²	0,75-2,5	0,75-2,5	0,75-2,5	0,75-2,5	0,75-2,5	0,75-2,5	1-2,5	0,75-2,5
	flexible	mm ²	0,75-2,5	0,75-2,5	0,75-2,5	0,75-2,5	0,75-2,5	0,75-2,5	0,75-2,5	0,75-2,5
	flexible with multicore cable end	mm ²	0,5-1,5	0,5-1,5	0,5-1,5	0,5-1,5	0,5-1,5	0,5-1,5	0,75-2,5	0,5-1,5
	solid	AWG	14 - 12	14 - 12	14 - 12	14 - 12	14 - 12	14 - 12	14 - 12	14 - 12
	flexible	AWG	18 - 12	18 - 12	18 - 12	18 - 12	18 - 12	18 - 12	18 - 12	18 - 12
Cables per clamp			2	2	2	2	2	2	2	2

Data according to CSA, UL and CUL

Type		HN	HTN	HA	HB..	HKT, HKA HKF	K2-DK K2-SK	K2-TP	K2-L ²⁾
Rated operational current "General Use"	A	10	10	16	10	10	-	10	-
Rated operational voltage	max. V AC	600	600	600	600	600	-	600	600
Auxiliary Contacts		A600	A600	A600	A600	A600	-	A600	Intermittent duty

1) Suitable for: earthed-neutral systems, overvoltage category I to IV, pollution degree 3 (standard-industry): Uimp = 8kV. Data for other conditions on request.

2) Command duration min. 30ms, 10% duty cycle, max. 30 eec.

Contactors and Accessories

Wiring diagrams

Auxiliary contact blocks

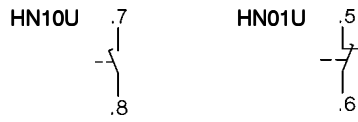
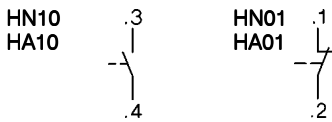

Snap-on momentary contact blocks

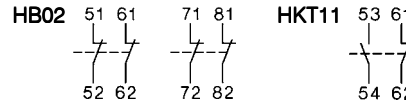
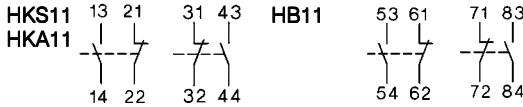
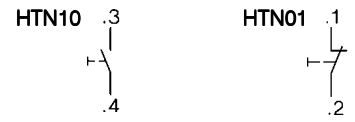

HB11, HB02:
Correct terminal marking
is given by mounting.

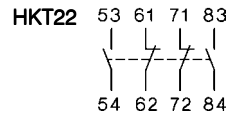
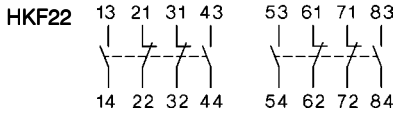

Pneumatic timer

on-delayed

K2-TP..E

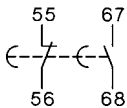

off-delayed

K2-TP..A

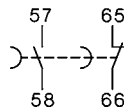

Indicator units

Coil current indicator

K2-ING
K2-INR

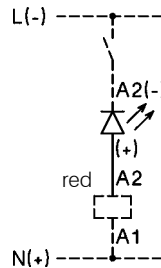

Voltage indicator

K2-UN
K2-UNR

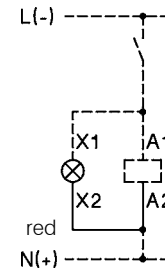

Latch

K2-L..

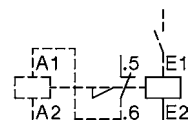

Fuse holder

K2-F



with rectifier

K2-RF1
K2-RF3

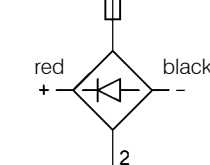

Colours mentioned in
wiring diagram refer to
the outgoing
connection wires
of the device.

Interface

K2-IM

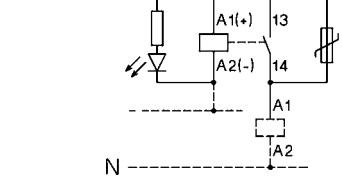

Regulation of switch position of aux. contact block HKF22 for contactors K3-450 to K3-860

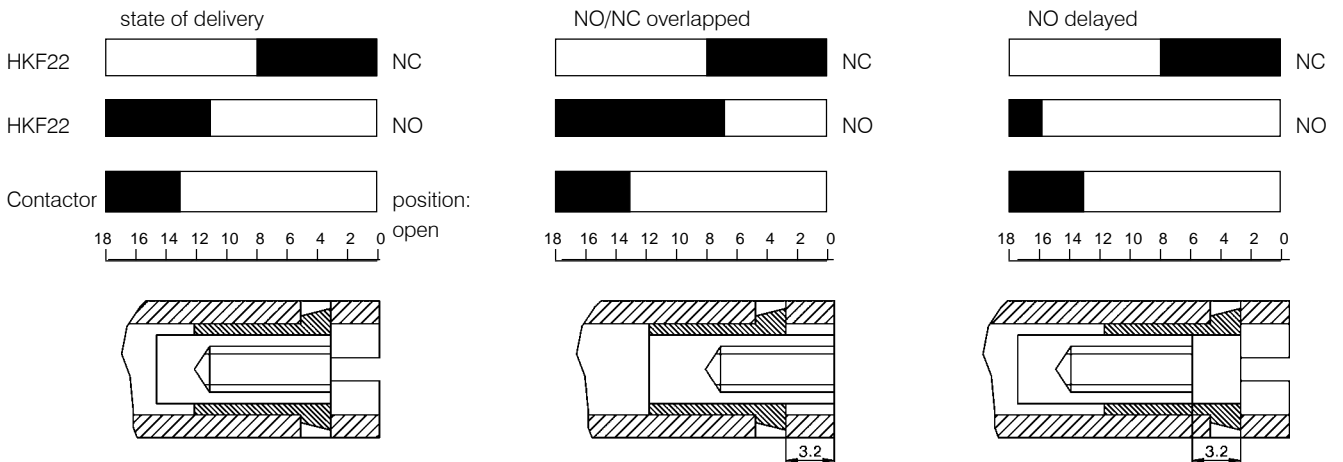

Standard position of regulation screw

Regulation screw position (unscrew by 4 turns)

Regulation screw position (screw by 4 turns)

Contactors

Dimensions

AC operated

K3-10N..
K3-14N..
K3-18N..
K3-22N..

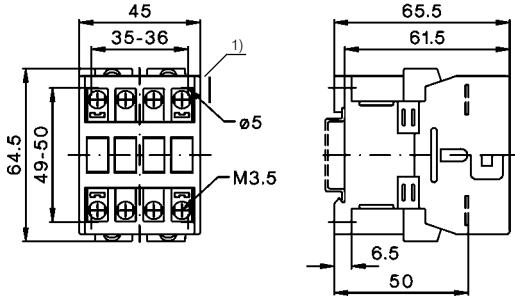

K3-24..
K3-32..
K3-40..

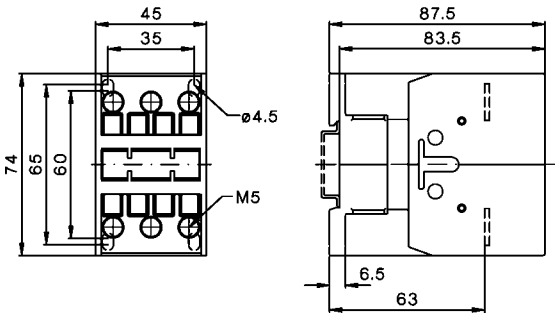

K3-50..
K3-62..
K3-74..

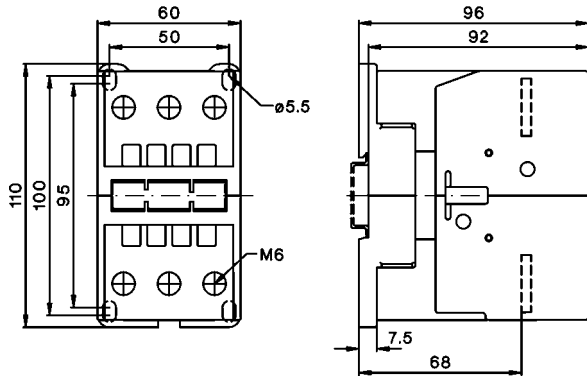

AC and DC operated

K3-90..
K3-115..

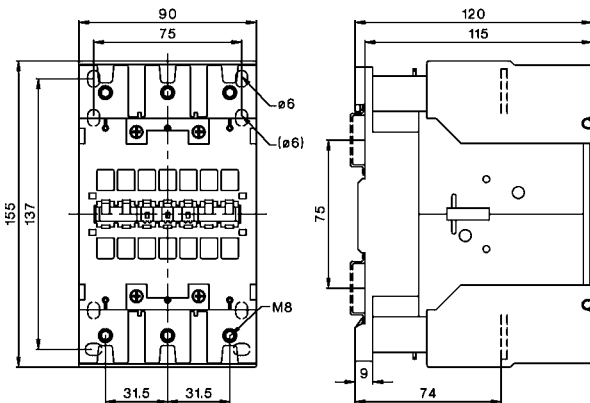

DC operated

KG3-10..
KG3-14..
KG3-18..
KG3-22..

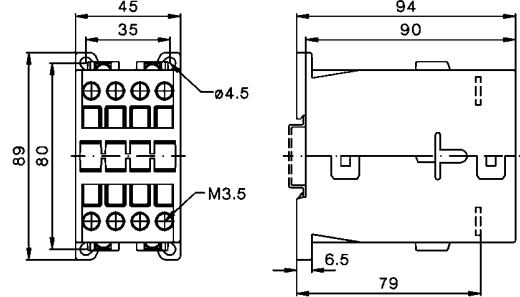

KG3-24..
KG3-32..
KG3-40..

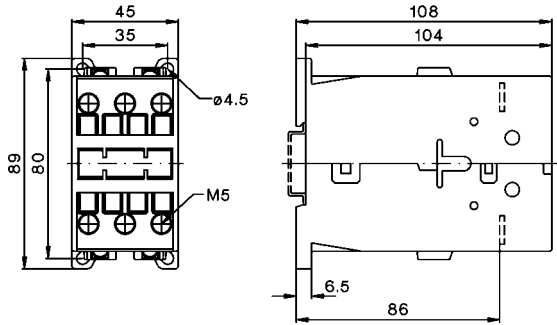

K3-50..=
K3-62..=
K3-74..=

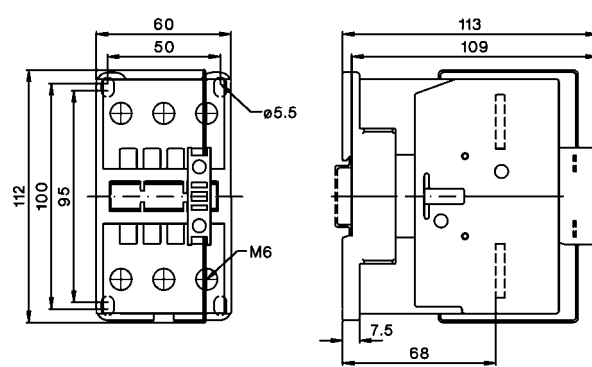

1) Minimum side distance to
conductive parts for coil voltage:
500V $U_{imp}=6kV$ 2mm
660-690V $U_{imp}=8kV$ 4,5mm

Contactors

Dimensions

AC operated, DC operated

K3-151..
K3-176..

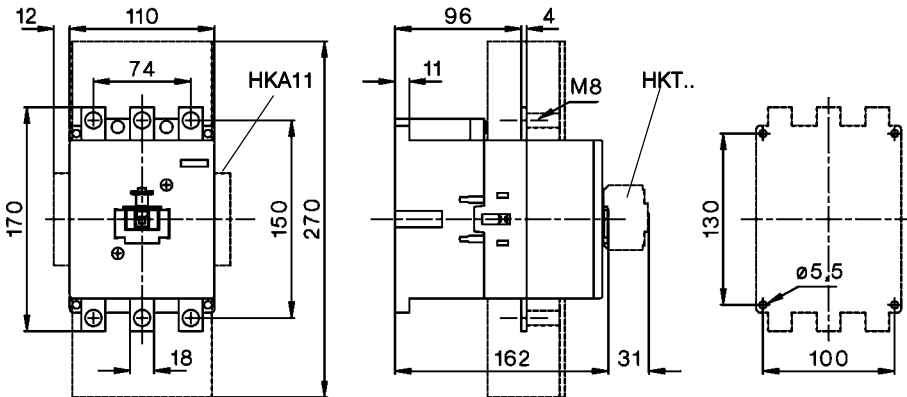

K3-210..
K3-260..
K3-316..

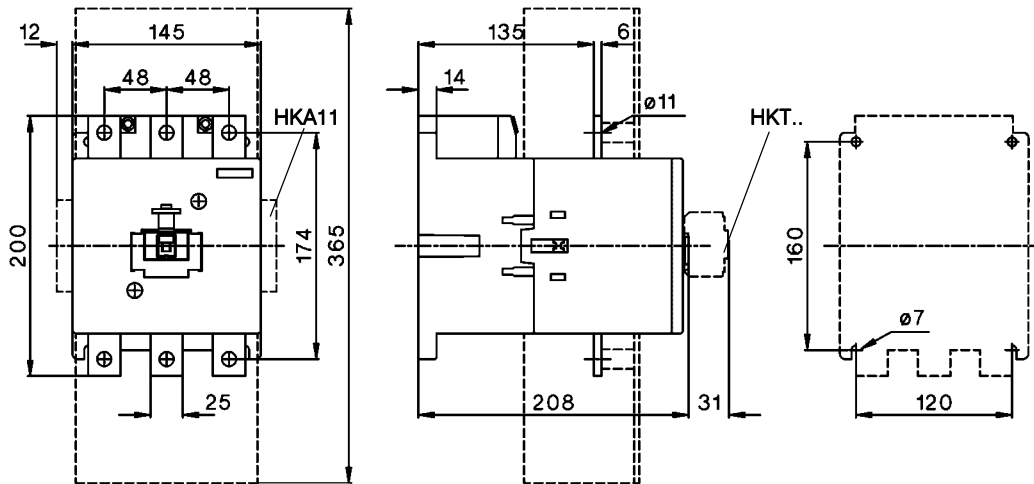

K3-450..
K3-550..

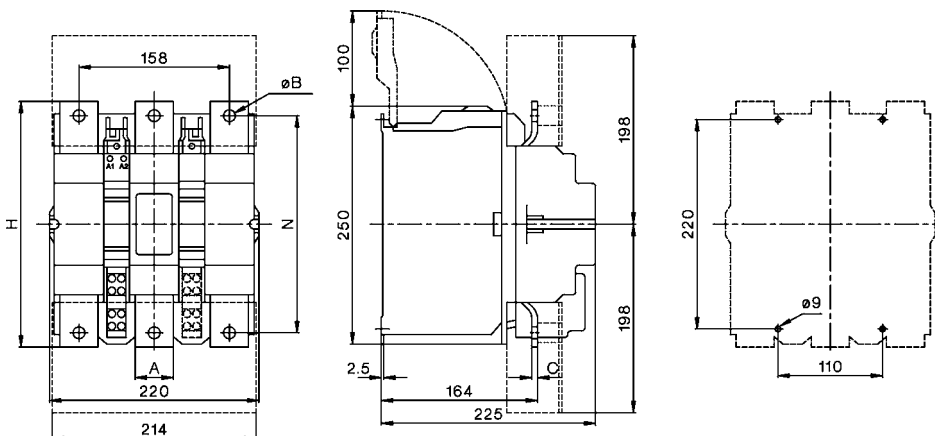

Typ	A	B	C	H	N
K3-450	40	10,5	4	233	206
K3-550	40	12,5	6	258	228

Contactors

Dimensions

AC and DC operated

K3-700..
K3-860..

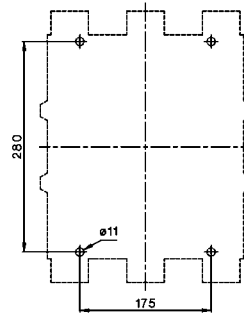
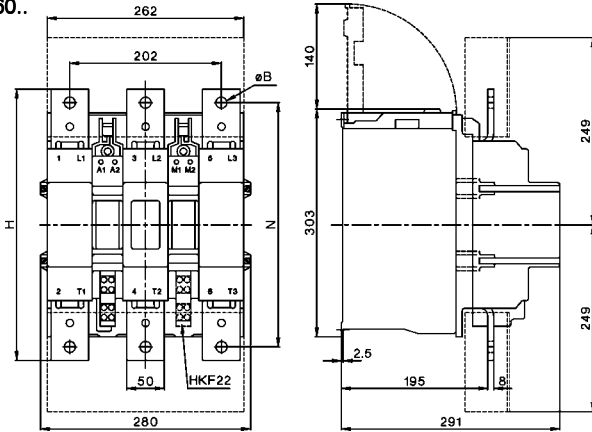

Typ	B	H	N
K3-700	13	310	277
K3-860	15	361	325

K3-1000..
K3-1200..

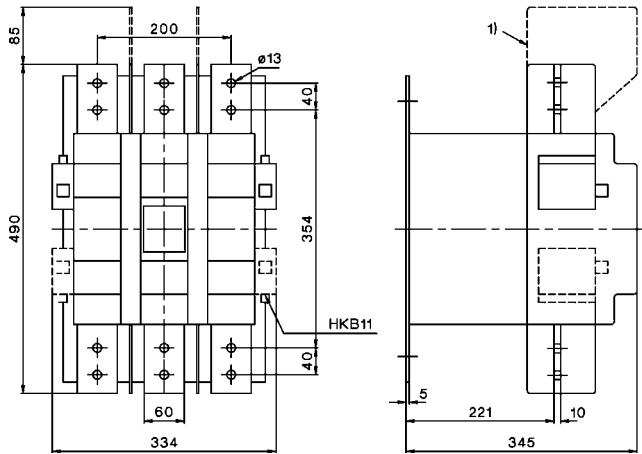

1) for K3-1200 in UL conformity application only

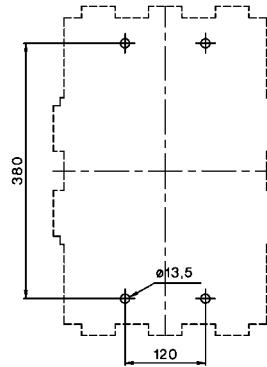

Capacitor switching contactors, AC operated

K3-18NK..

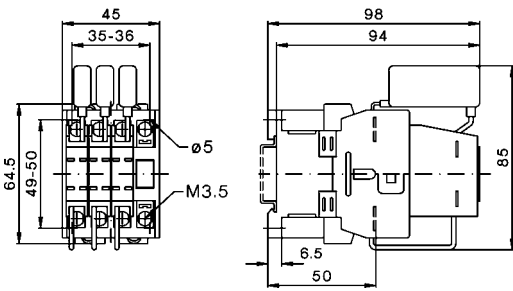

K3-24K..
K3-32K..

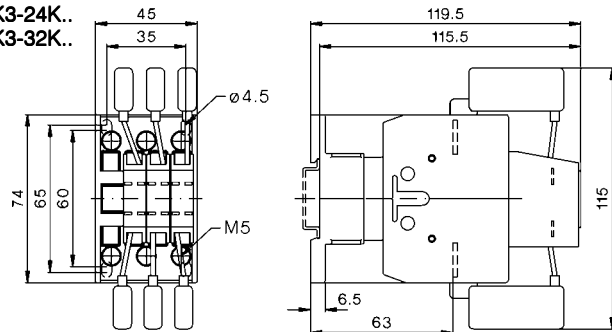

K3-50K..
K3-62K..
K3-74K..

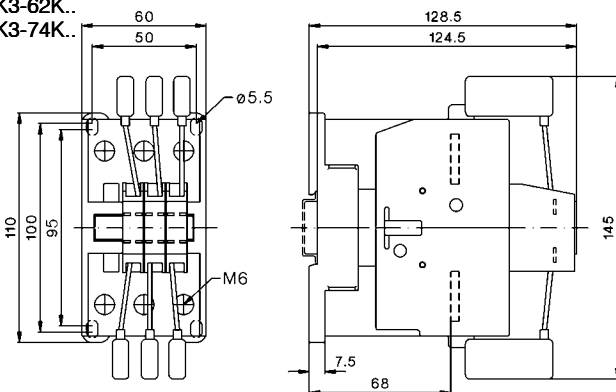

K3-90K..
K3-115K..

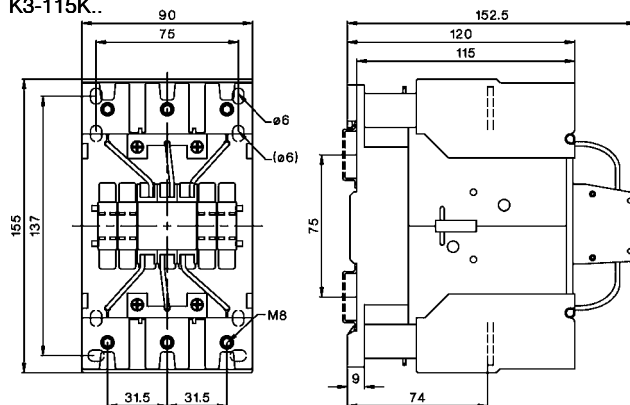

Contactors

Dimensions

Contactors DC operated

K3-10N..=
 K3-14N..=
 K3-18N..=
 K3-22N..=

K3-24..=
 K3-32..=
 K3-40..=

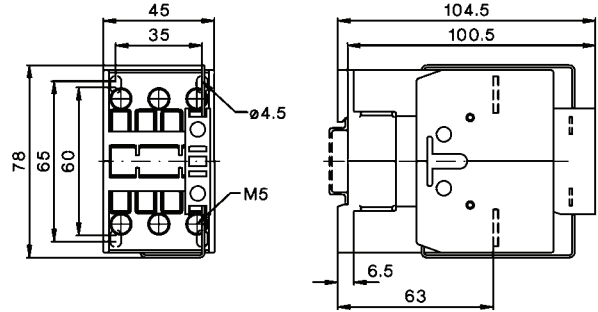
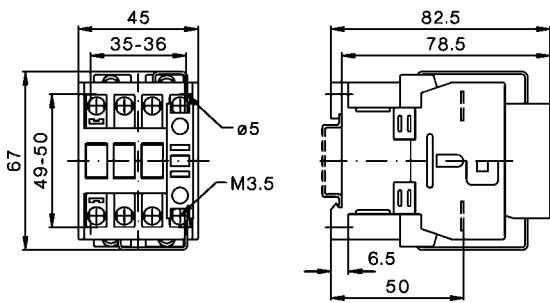

Contactors 4-pole, AC operated

K3-10NA00-40
 K3-14NA00-40
 K3-18NA00-40
 K3-22NA00-40

K2-23A00-40
 K2-30A00-40
 K2-37A00-40

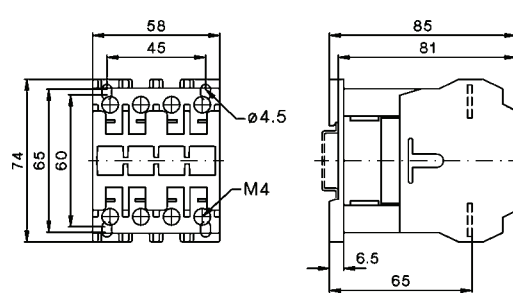
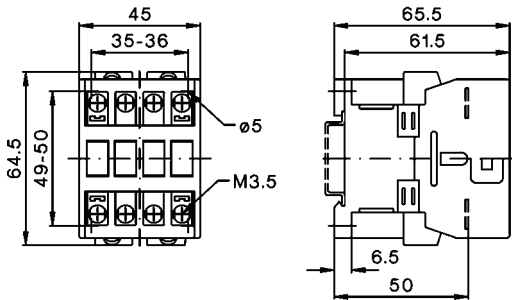

Contactors 4-pole, AC operated

K2-45A00-40
 K2-60A00-40

K3-116A00-40
 K3-151A00-40
 K3-176A00-40

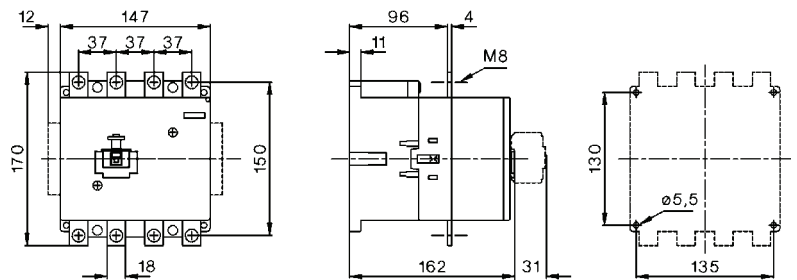
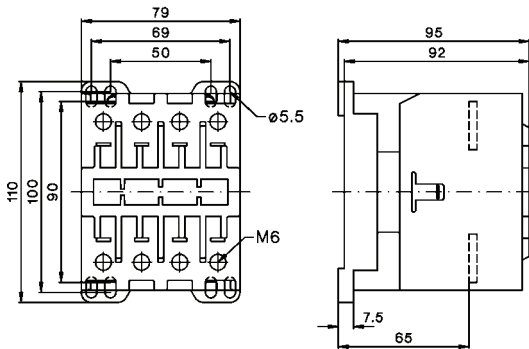

Contactors 4-pole, AC and DC operated

K3-210A00-40
 K3-260A00-40
 K3-316A00-40

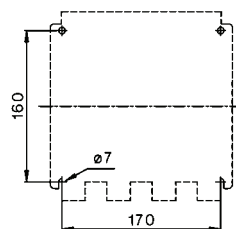
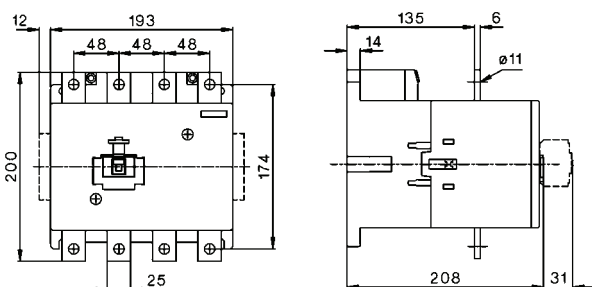

Contactors

Dimensions Accessories

Aux. cont. blocks, terminal blocks

Snap-on momentary cont. blocks

Auxiliary contact blocks

HN10, HN01 K2-SK, K2-DK

HTN10, HTN01

HA10, HA01

HB11, HB02

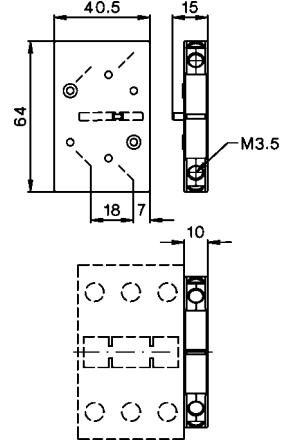
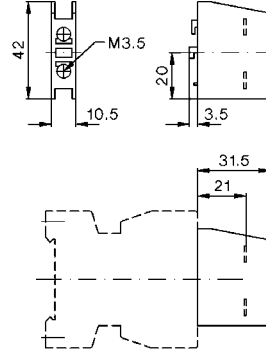
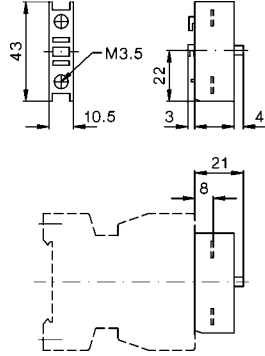
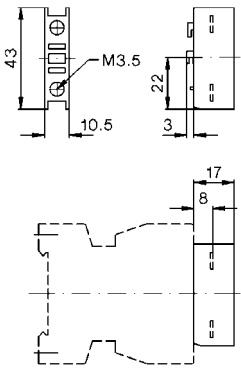

4. pole for contactors K3-200 to K3-1200

Type	A	B	C	D	E	F	G	H
NP175	223	148	26	52	98	5	122	M8
NP350	223	148	26	52	98	5	122	M8
NP325	262	148	26	55	116	5	122	M10
NP500	294	220	53	72	138	5	152	M12
NP760	294	220	53	72	138	5	152	M12
NP501	348	220	53	73	145	5	152	M12
NP1000	348	220	53	73	145	8	152	M12
NP1001	410	220	53	110	157	8	152	M12

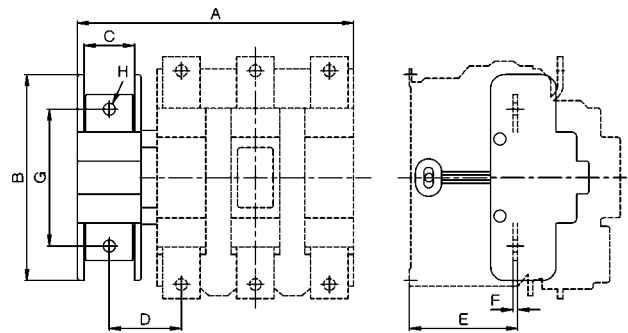

Electronic timer on-delay

K2-TE..

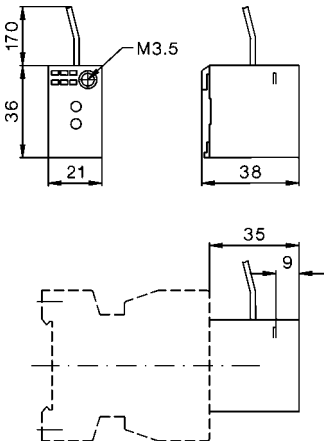

Electronic timer off-delay

K2-TA..

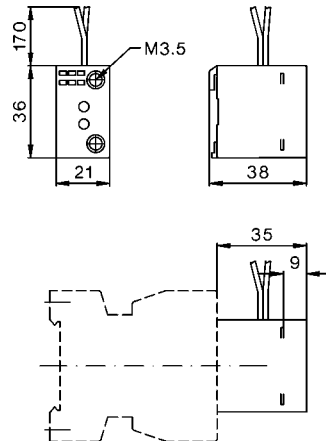

Pneumatic timer

K2-TP

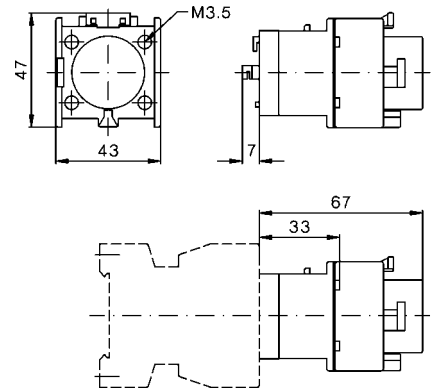

Contactors

Dimensions Accessories

Mechanical interlocks

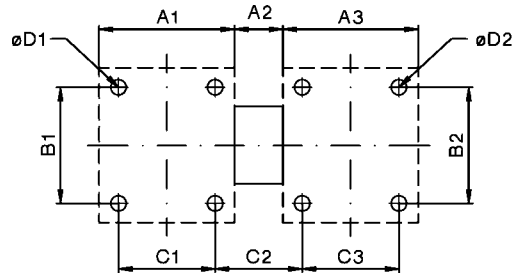

Type	Contactor 1	Contactor 2	A1	A2	A3	B1	B2	C1	C2	C3	D1	D2	
LG10889	K3-07 to K3-40	K3-07 to K3-40	45	7	45	50	50	35	17	35	4,5	4,5	
LG10889	KG3-07 to KG3-22	KG3-07 to KG3-22	45	7	45	80	50	35	17	35	4,5	4,5	
LG10889	KG3-24 to KG3-40	KG3-22 to KG3-40	45	7	45	80	50	35	17	35	4,5	4,5	
LG10890	K3-50 to K3-74	K3-24 to K3-40	60	12	55	100	65	50	22	45	5,5	4,5	
LG10890	K3-50 to K3-74	K3-50 to K3-74	60	12	60	100	100	50	22	50	5,5	5,5	
LG11478	K3-90 bis K3-115	K3-90 bis K3-115	90	12	90	100	100	75	27	75	5,5	5,5	
LG8511	K65 - K110	K65 - K110	90	12	90	100	100	75	27	75	6	6	
LG11223H	K3-151, -176	K3-151, -176	110	30	110	130	130	100	40	100	6	6	3-pole contactor
LG11223H	K3-116,-151, -176	K3-116,-151, -176	147	30	147	130	130	135	42	135	6	6	4-pole contactor
LG11223H	K3-210, -260, -316	K3-210, -260, -316	145	30	145	160	160	120	55	120	6	6	3-pole contactor
LG11223H	K3-210, -260, -316	K3-210, -260, -316	193	30	193	160	160	170	55	170	6	6	4-pole contactor
LG10400H	K3-450, K3-550	K3-450, K3-550	220	42	220	220	220	110	152	110	9	9	
LG10402H	K3-700, -860	K3-700, -860	280	32	280	280	280	175	137	175	11	11	
LG10403H	K3-1000, -1200	K3-1000, -1200	334	46	334	380	380	120	260	120	13,5	13,5	
LG10399H	K3-450, -550	K3-700, -860	220	37	280	220	280	110	144,5	175	9	11	
LG10401H	K3-700, -860	K3-1000, -1200	280	73	334	280	380	175	232,5	120	11	13,5	

LG10400V, LG10402V

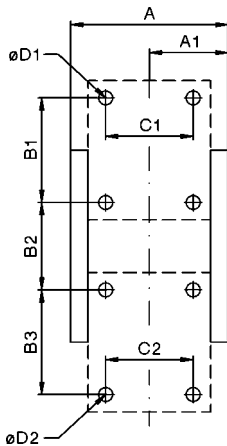

LG10399V

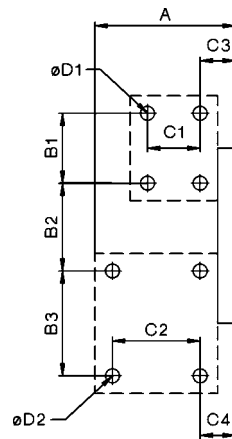

LG10403V, LG10401V

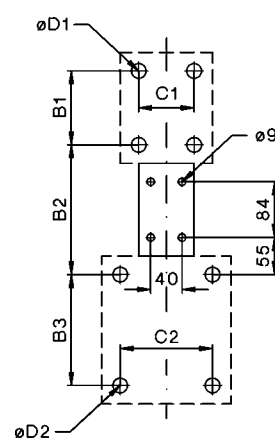

Type	Contactor 1	Contactor 2	A	A1	B1	B2	B3	C1	C2	C3	C4	D1	D2
LG10400V	K3-315 - K3-550	K3-315 - K3-550	250	134	220	94	220	110	110	-	-	9	9
LG10402V	K3-700, -860	K3-700, -860	302	162	280	200	280	175	175	-	-	11	11
LG10403V	K3-1000, -1200	K3-1000, -1200	-	-	380	280	380	120	120	-	-	13,5	13,5
LG10399V	K3-450, -550	K3-700, -860	302	-	220	150	280	110	175	51	74,5	9	11
LG10401V	K3-700, -860	K3-1000, -1200	-	-	280	240	380	175	120	-	-	11	13,5

Contactors

Dimensions Accessories

Latch

K2-L..

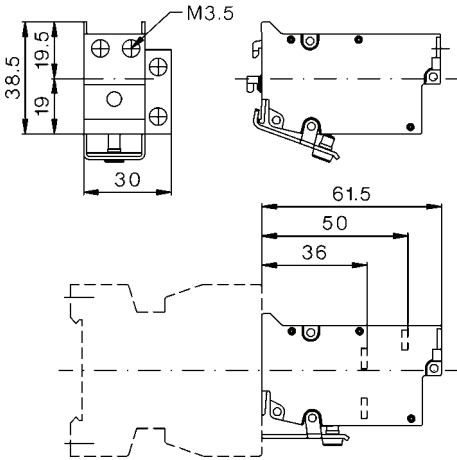

Contactors with additional terminals

LG9339 (2 x 3 pieces)
for K3-10N. to K3-22N.

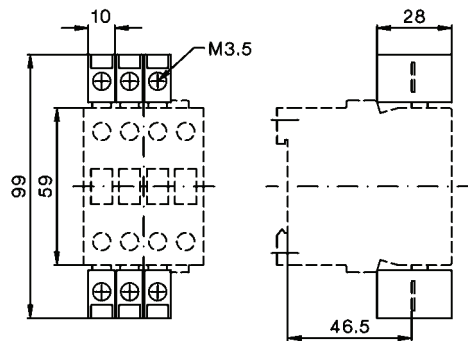

Indicator units

K2-ING, K2-INR
K2-UN, K2-UNR

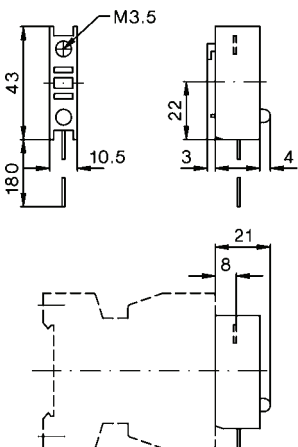

Fuse holder

K2-RF

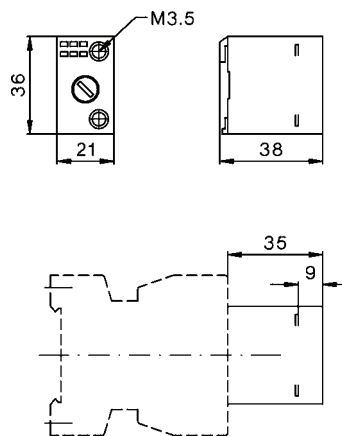

Fuse holder with rectifier

K2-RF1
K2-RF3

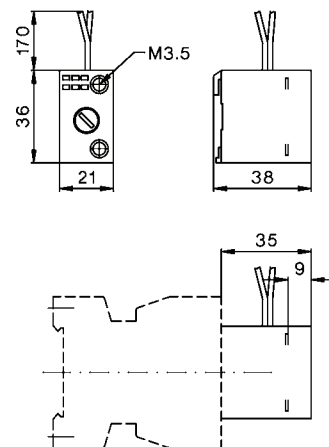

Contactors

Dimensions Accessories

Interface

K2-IM

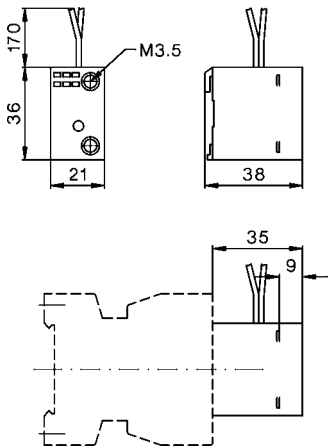

Snap-on adapter

K2-SM

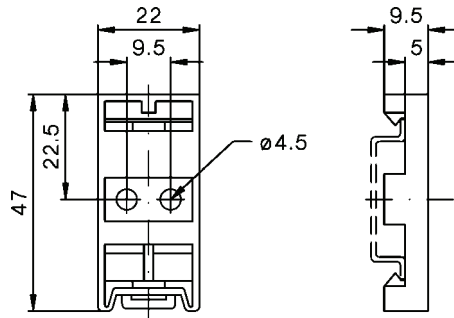

Suppressor units

VG-K2/..

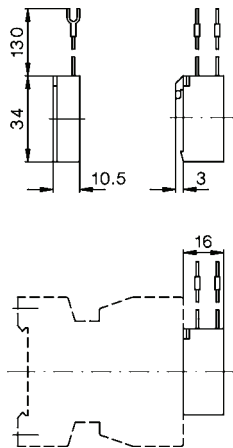

RC-K3N ..

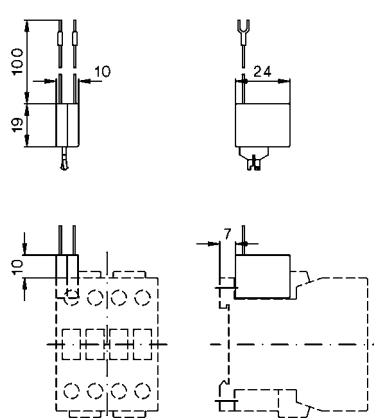

RC-AD.., LG-ADZ.., LG-A03

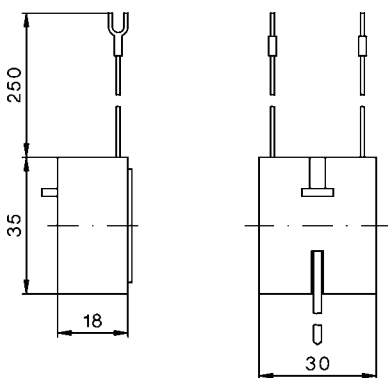

Marking systems

marking label
P487-1 or P245-.

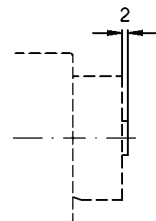

Contactors

Position of terminals

K3-10ND10
K3-14ND10
K3-18ND10
K3-22ND10
K3-18NK10

K3-10ND01
K3-14ND01
K3-18ND01
K3-22ND01
K3-18NK01

K3-24A00, K3-24K00
K3-32A00, K3-32K00
K3-40A00

K3-50A00, K3-50K00
K3-62A00, K3-62K00
K3-74A00, K3-74K00

K3-10NA00-40
K3-14NA00-40
K3-18NA00-40
K3-22NA00-40
K2-23A00-40 bis
K2-60A00-40

K85A22
K110A22

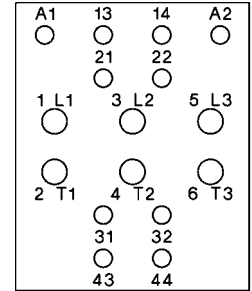
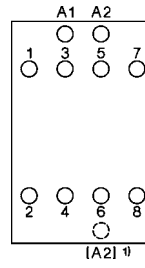
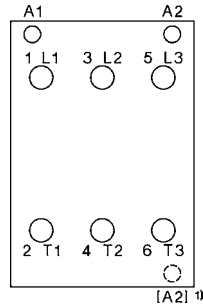
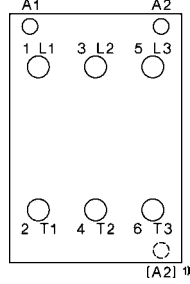
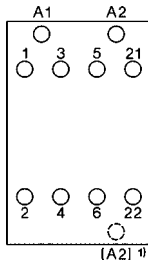
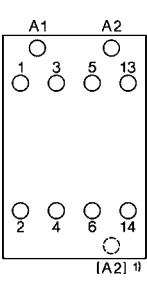

K3-90A00
K3-115A00

K3-151A00
K3-176A00
K3-210A00
K3-260A00
K3-316A00

K3-151A00-40
K3-176A00-40
K3-210A00-40
K3-260A00-40
K3-316A00-40

K3-450A22
K3-550A22
K3-700A22
K3-860A22

K3-1000A12
K3-1200A12

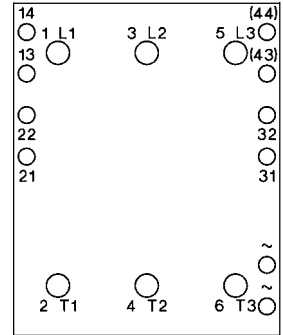
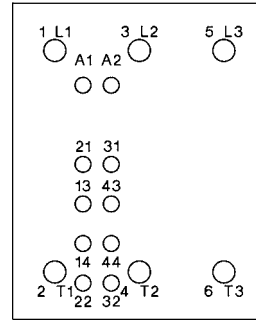
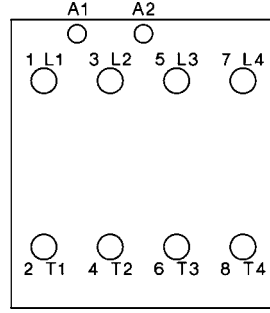
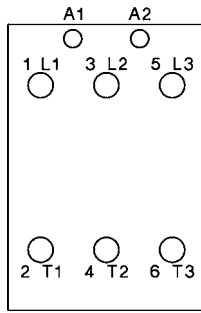
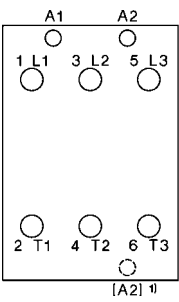

KG3-10A10
KG3-14A10
KG3-18A10
KG3-22A10

KG3-10A01
KG3-14A01
KG3-18A01
KG3-22A01

KG3-10A00-40
KG3-14A00-40
KG3-18A00-40
KG3-22A00-40

KG3-24A00
KG3-32A00
KG3-40A00

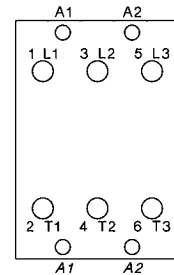
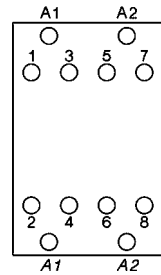
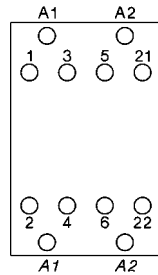
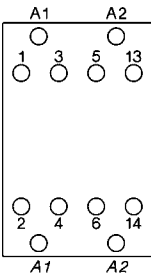

K3-10ND10=
K3-14ND10=
K3-18ND10=
K3-22ND10=

K3-10ND01=
K3-14ND01=
K3-18ND01=
K3-22ND01=

K3-24A00=
K3-32A00=
K3-40A00=

K3-50A00=
K3-62A00=
K3-74A00=

K85A21=
K110A21=

K3-1000A12=
K3-1200A12=

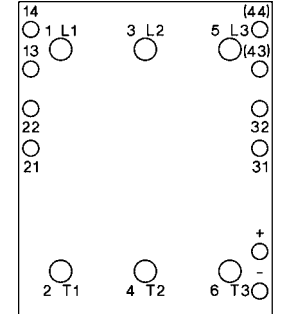
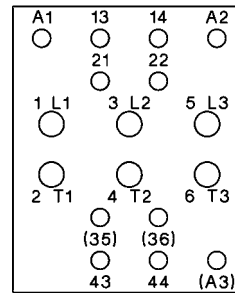
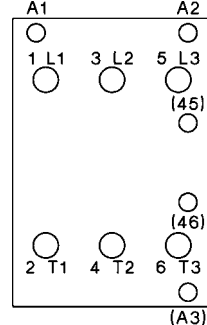
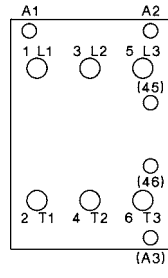
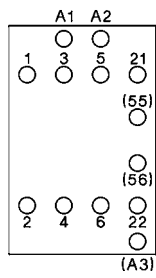
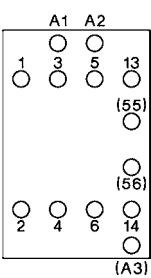

1) Type-suffix "EUR" with additional coil terminal
Ordering example: K3-10A10EUR 230



Star-Delta Starters Open Type 74



Star-Delta Starters Enclosed Enclosure for Star-Delta Starters 76

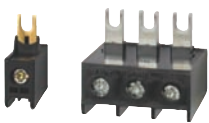

Accessories 77



Reversing Contactors 78



Pole Changing Starters 80



Technical Data 82

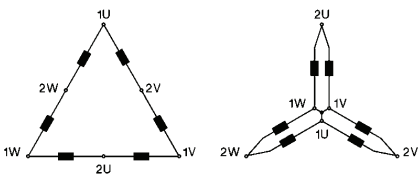

Wiring Diagrams 85

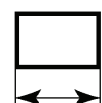

Dimensions 89

Star-Delta Starters Open Type

AC Operated

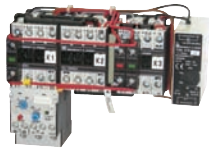

Ratings		Rated Current		Wired to accept	Type	Coil voltage ¹⁾	Pack	Weight
AC3				Overload Relay		220-240V 50Hz	pcs.	kg/pc.
380V				Relay		380-415V 50Hz		
400V	660V	AC3		Type				
415V	500V	690V	400V					
kW	kW	kW	A					
7,5	7,5	11	16	U3/32 U12/16E K3	K3NY15 ...	230 400	1	0,9
15	18,5	15	30		K3NY26 ...		1	0,9
22	30	22	45	U3/42	K3Y40 ...		1	1,4
30	37	30	60		K3Y52 ...		1	1,8
45	55	45	85	U3/74	K3Y80 ...		1	3,5
55	75	55	109		K3Y100 ...		1	3,7
75	90	90	150	U85	K3Y140 ...		1	6,6
110	132	110	205		K3Y200 ...		1	7
132	160	160	240	U180	K3Y240 ...		1	15
160	180	180	300		K3Y300 ...		1	15

Star-delta starters are wired to accept thermal overload relay. The thermal overload relay has to be ordered separately. For full load current setting use the YD-dial of thermal overload relay.

Ordering Example: Star-Delta Starter, open type, rated AC3 at 400V 205A rated control voltage 230V 50Hz - Order Type: K3Y200 230 + U85 120

Thermal Overload Relays

Rated Motor Current A	Type	Pack pcs.	Weight kg/pc.	Wiring Diagram
--------------------------	------	--------------	------------------	----------------

For Star-Delta Starters K3NY15.. to K3Y40..



7 - 10,5	U12/16E 6 K3	1	0,10	
10,5 - 15,5	U12/16E 9 K3	1	0,10	
14 - 19	U12/16E 11 K3	1	0,10	
18 - 24	U12/16E 14 K3	1	0,10	
23 - 31	U12/16E 18 K3	1	0,10	

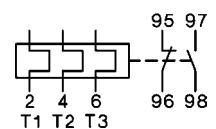

manual reset

For Star-Delta Starters K3NY15.. to K3Y52..



7 - 10,5	U3/32 6	1	0,14	
10,5 - 15,5	U3/32 9	1	0,14	
14 - 19	U3/32 11	1	0,14	
18 - 24	U3/32 14	1	0,14	
23 - 31	U3/32 18	1	0,14	
30 - 41	U3/32 24	1	0,14	
40 - 55	U3/32 32	1	0,14	

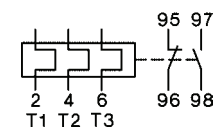

manual and auto reset

For Star-Delta Starters K3Y40.., K3Y52..



24 - 35	U3/42 20	1	0,30	
35 - 48	U3/42 28	1	0,30	
48 - 73	U3/42 42	1	0,30	

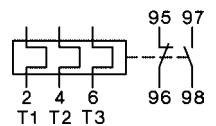

manual and auto reset

1) Coil voltage range and other coil voltages see page 82

Components for Combinations			Electronic Timer	Mechanical Interlock between K2 and K3	Star-Delta Starter Connector	Auxiliary Contacts Built-in for use on Contactor			Free Space for Aux. Contact Blocks on Contactor		
Line Contactor	Delta Contactor	Star Contactor				Line K1	Delta K2	Star K3	Line K1	Delta K2	Star K3
K1 Type	K2 Type	K3 Type	K4 Type	K2 and K3 Type	Type	NO/NC	NO/NC	NO/NC	HN..	HA..	
K3-10ND01 + HN10	K3-10ND01	K3-10ND10 + HN10 + HN01	Y9A	LG10889	K3NY-VB10	-	-	-	3	4	2
K3-18ND01 + HN10	K3-18ND01	K3-14ND10 + HN10 + HN01	Y9A	LG10889	K3NY-VB10	-	-	-	3	4	2
K3-24A00 + HN10 + HN01	K3-24A00 + HN01	K3-24A00 + 2HN10 + HN01	Y9A	LG10889	K3Y-VB24	-	-	-	2	3	1
K3-32A00 + HN10 + HN01	K3-32A00 + HN01	K3-24A00 + 2HN10 + HN01	Y9A	LG10889	K3Y-VB24	-	-	-	2	3	1
K3-50A00 + HN01 + HN10	K3-50A00 + HN01	K3-32A00 + 2HN10 + HN01	Y9A	LG10890	-	-	-	-	2	3	1
K3-62A00 + HN01 + HN10	K3-62A00 + HN01	K3-50A00 + 2HN10 + HN01	Y9A	LG10890	-	-	-	-	2	3	1
K3-90A00 + HN01 + HN10	K3-90A00 + HN01	K3-90A00 + 2HN10 + HN01	Y9AL	LG11478	-	-	-	-	5	6	4
K3-115A00 + HN01 + HN10	K3-115A00 + HN01	K3-90A00 + 2HN10 + HN01	Y9AL	LG11478	-	-	-	-	5	6	4
K3-151A00 + HKT11	K3-151A00 + HKT11	K3-151A00 + HKT22	Y9AL	LG11223H	-	-	1/-	-/1	2	1	1
K3-176A00 + HKT11	K3-176A00 + HKT11	K3-151A00 + HKT22	Y9AL	LG11223H	-	-	1/-	-/1	2	1	1

Applications

The star-delta starting method is only practicable in such cases where the motor windings are connected in delta configuration for normal operation and the torque which is needed during the starting period is not higher than approx. 30% of the rated torque. The starting current drawn from the line will be approx. 2 to 2,7 times the rated motor current.

Time setting

The transition from start (star configuration) to normal operation (delta configuration) should be after the motor achieves practically full rotational speed. The use of star-delta timer Y9A with a dwell period of approx. 25ms provides a careful operation of motor and drive equipment.

Thermal Overload Relays

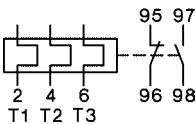
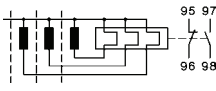
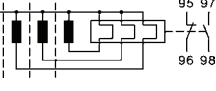
Rated Motor Current A	Type	Pack pcs.	Weight kg/pc.	Wiring Diagram	
				Diagram	Description
For Star-Delta Starters K3Y80.., K3Y100..					
35 - 48	U3/74 28	1	0,40		manual and auto reset
48 - 73	U3/74 42	1	0,40		
70 - 90	U3/74 52	1	0,40		
90 - 112	U3/74 65	1	0,40		
For Star-Delta Starters K3Y140.., K3Y200..					
104 - 156	U85 90	1	0,90		manual eset
140 - 207	U85 120	1	0,90		
For Star-Delta Starters K3Y240.., K3Y300..					
208 - 312	U180 180	1	1,5		manual and auto reset

Star-Delta Starters Enclosed Type

AC Operated

Ratings		Rated Current	Optional Extras	Wired to accept Overload Relay	Type	Coil voltage ¹⁾	Pack pcs.	Weight kg/pc.
AC3						230		
380V						400		
400V	660V	AC3						
415V	500V	690V	400V					
kW	kW	kW	A	Type				



Plastic Enclosed, protected to IP65

15	18,5	15	30	ST	U3/32	K3NY26P . . .	1	1,8
22	30	22	45	ST, H	U3/42	K3Y40P . . .	1	3,8
30	37	30	60	ST, H		K3Y52P . . .	1	4,2
45	55	45	85	ST, H	U3/74	K3Y80P . . .	1	5,9
55	75	55	109	ST, H		K3Y100P . . .	1	8,7

Sheet Steel Enclosed, protected to IP54



15	18,5	15	30	ST, H	U3/32	K3NY26B . . .	1	4,8
22	30	22	45	ST, H	U3/42	K3Y40B . . .	1	4,8
30	37	30	60	ST, H		K3Y52B . . .	1	5,2
45	55	45	85	ST, H	U3/74	K3Y80B . . .	1	15
55	75	55	109	ST, H		K3Y100B . . .	1	15
75	90	90	150	ST, H	U85	K3Y140B . . .	1	22
110	132	110	205	ST, H		K3Y200B . . .	1	22

1) Coil voltage range and other coil voltages see page 82

Type-suffix for optional extras

Start-Stop Push ButtonsT . . .		
Selector SwitchW . . .		
Control Circuit Fuse <250V (1 piece)ST . . .	
>250V (2 pieces)ST . . .	
Run Hour MeterH . . .		

Ordering Example: Star-Delta Starter, steel sheet enclosed, with selector switch and run hour meter rated AC3 at 400V 82A, rated control voltage 230V 50Hz - Order Type: K3Y80BWH 230 + U3/74 52

Enclosures for Star Delta Starter



for Starter	accept Overload Relay	Type	Pack pcs.	Weight kg/pc.
Plastic IP65				
K3Y15, K3Y26	U3/32	K3Y26P-G3	1	1,0
K3Y40, K3Y52	U3/42, U3/32	K3Y40/52P-G3	1	2,4
Sheet Steel IP54				
K3Y15, K3Y26	U3/32	K3Y26B-G3	1	3,4
K3Y40, K3Y52	U3/42, U3/32	K3Y40/52B-G3	1	3,4

Star-Delta Starter Connector



For Star-Delta Starter Types	Type	Pack pcs.	Weight kg/pc.
K3NY15, K3NY26	K3NY-VB10	1	0,02
K3Y40, K3Y52	K3Y-VB24	1	0,03

Additional Terminals



For Star-Delta Starter Types	Cable cross-section mm ²	Type	Pack pcs.	Weight kg/pc.
Line Conn. Line Contactor	Motor Conn. Overload Relay			
Single pole with Fingertouch Protection				
K3Y15, K3Y26	U12/16	0,75 - 10 solid 0,75 - 6 flex.	LG9339	6 0,009
Three-pole with Fingertouch Protection				
	U3/42	4 - 35 strand. 4 - 25 flex.	LG7559	1 0,052

Electronic Timers for Star-Delta Starters



Rated Control Voltage V	Time Range s	Delay Time ms	Rated Current 230V A	Rated Current 400V A	Type	Pack pcs.	Weight kg/pc.
24 - 60V AC	1 - 20	20 - 25	6	4	Y9A 60	1	0,075
110 - 415V AC	1 - 20	20 - 25	6	4	Y9A 415	1	0,075
24 - 60V~	1 - 20	40 - 80	6	4	Y9AL 60	1	0,075
110 - 415V~	1 - 20	40 - 80	6	4	Y9AL 415	1	0,075

Time repeat accuracy	± 1%	Power consumption at	24V	0,2VA
Minimum interval between operations	2s		60V	5VA
Short circuit protection	4A gl (gG)		220-240V	2VA
			380-415V	7VA

Mounting Bar



Specification	Type	Pack pcs.	Weight kg/pc.
For screw mounting of electronic timer Y9..	LG7735	10	0,09

Star-Delta Starters in Special Versions

Starters for Longer Starting Time

For longer starting times the thermal overload relay is mounted on delta-contactor. The motor is not protected in Y-connection. The timer used for this starter-type is the type Y91A, time range is 10 to 60s. Principal wiring diagram see page 86.

Ordering Example: K3YL52 230

Starters with two Thermal Overload Relays on request

Basic circuit diagram see page 86

Reversing Contactors with Mechanical Interlock

AC Operated

Ratings			Rated Current	Wired to accept Overload Relay page 102 Type	Type	Coil voltage ¹⁾ 110V 50Hz 220-240V 50Hz 380-415 50Hz	Pack pcs.	Weight> kg/pc.
AC3 380V 400V 415V kW	500V kW	660V 690V kW						
			AC3 400V A			110 230 400 ↓		

Open Type

4	5,5	5,5	10	U3/32 U12/16E K3	K3NWU10 ...		1	0,6
7,5	10	7,5	18		K3NWU18 ...		1	0,6
11	15	15	24	U3/42	K3WU24 ...		1	1,2
15	18,5	18,5	32		K3WU32 ...		1	1,4
22	30	30	50	U3/74	K3WU50 ...		1	2,5
30	37	37	62		K3WU62 ...		1	2,5
37	45	45	74		K3WU74 ...		1	2,5



Sheet Steel Enclosed, protected to IP54

4	5,5	5,5	10	U3/32	K3WU10B ...		1	3,9
7,5	10	7,5	18		K3WU18B ...		1	4,1
11	15	15	24	U3/42	K3WU24B ...		1	4,5
15	18,5	18,5	32		K3WU32B ...		1	4,7
22	30	30	50	U3/74	K3WU50B ...		1	7,1
30	37	37	62		K3WU62B ...		1	7,1



Reversing Starter Connector



For Reversing Starter Types

	Type	Pack pcs.	Weight kg/pc.
K3WU10, K3WU18	K3NW-VB10	1	0,02
K3WU24, K3WU32	K3W-VB24	1	0,025

1) Other coil voltages see page 39

Components for Combinations		Mechanical Interlock	Reversing Starter Connector	Auxiliary Contacts Built-in for use on Contactor		Free Space for Aux. Contact Blocks on Contactor	
Left Hand Side Contactor	Right Hand Side Contactor			K1 NO/NC	K2 NO/NC	K1 HN.. or HA..	K2
K1 Type	K2 Type	Type	Type				
K3-10ND10 + HN01	K3-10ND10 + HN01	LG10889	K3NW-VB10	-	-	3	3
K3-18ND10 + HN01	K3-18ND10 + HN01	LG10889	K3NW-VB10	-	-	3	3
K3-24A00 + HN10 + HN01	K3-24A00 + HN10 + HN01	LG10889	K3W-VB24	-	-	2	2
K3-32A00 + HN10 + HN01	K3-32A00 + HN10 + HN01	LG10889	K3W-VB24	-	-	2	2
K3-50A00 + HN10 + HN01	K3-50A00 + HN10 + HN01	LG10890	-	-	-	2	2
K3-62A00 + HN10 + HN01	K3-62A00 + HN10 + HN01	LG10890	-	-	-	2	2
K3-74A00 + HN10 + HN01	K3-74A00 + HN10 + HN01	LG10890	-	-	-	2	2
K3-10A10 + HN01	K3-10A10 + HN01	LG10889	K3W-VB10	-	-	3	3
K3-18A10 + HN01	K3-18A10 + HN01	LG10889	K3W-VB10	-	-	3	3
K3-24A00 + HN10 + HN01	K3-24A00 + HN10 + HN01	LG10889	K3W-VB24	-	-	2	2
K3-32A00 + HN10 + HN01	K3-32A00 + HN10 + HN01	LG10889	K3W-VB24	-	-	2	2
K3-50A00 + HN10 + HN01	K3-50A00 + HN10 + HN01	LG10890	-	-	-	2	2
K3-62A00 + HN10 + HN01	K3-62A00 + HN10 + HN01	LG10890	-	-	-	2	2

Reversing Contactors for North America

AC Operated

Ratings			Rated Current	Wired to accept Overload Relay page 102 Type	Type	Coil voltage ¹⁾ 230-240V 50Hz 380-415V 50Hz	Pack pcs.	Weight> kg/pc.
AC3 at 380V	400V	415V						
415V kW	500V kW	690V kW	AC3 400V A					

Open Type

4	5,5	5,5	10	U3/32 U12/16E K3	KNW3-10 . . .	1	0,6
7,5	10	10	18		KNW3-18 . . .	1	0,6
11	15	15	24	U3/42	KW3-24 . . .	1	1,2
15	18,5	18,5	32		KW3-32 . . .	1	1,4
18,5	18,5	18,5	40		KW3-40 . . .	1	1,4



Pole Changing Starters

AC Operated

Ratings			Rated Current	Wired to accept Overload Relay page 102 Type	Type	Coil voltage ¹⁾ 230-240V 50Hz 380-415V 50Hz	Pack pcs.	Weight> kg/pc.
AC3 at 380V	400V	415V						
415V kW	500V kW	690V kW	AC3 400V A					

Open Type

7,5	10	10	18	2 x U3/32 2 x U12/16E K3	K3NPU18 . . .	1	1,0
11	15	15	24		K3NPU24 . . .	1	1,5
15	18,5	18,5	32	2 x U3/32	K3PU32 . . .	1	1,9
22	30	30	50	2 x U3/74	K3PU50 . . .	1	3,9
30	37	37	62		K3PU62 . . .	1	3,9



Sheet Steel Enclosed, protected to IP54

7,5	10	7,5	18	2x U3/32	K3NPU18B . . .	1	1,0
11	15	15	24		K3NPU24B . . .	1	1,5
15	18,5	18,5	32		K3PU32B . . .	1	1,9



1) Other coil voltages see page 40

Ordering Example: Pole Changing Starter, open version, rated AC3 at 400V 28A and 15A, control voltage 230V 50Hz
Order Type: K3PU32 230 + U3/32 32 + U3/32 18

Pole Changing Starters for Star-Delta Operation on request

1) Other coil voltages see page 39

Components for Combinations		Mechanical Interlock	Auxiliary Contacts Built-in for use on Contactor		Free Space for Aux. Contact Blocks on Contactor	
Left Hand Side Contactor	Right Hand Side Contactor		K1 NO/NC	K2 NO/NC	K1 HN.. or HA..	K2
K1 Type	K2 Type	Type				
K3-10ND01	K3-10ND01	LG10889	-	-	4	4
K3-18ND01	K3-18ND01	LG10889	-	-	4	4
K3-24A00 + HN01	K3-24A00 + HN01	LG10889	-	-	3	3
K3-32A00 + HN01	K3-32A00 + HN01	LG10889	-	-	3	3
K3-40A00 + HN01	K3-40A00 + HN01	LG10890	-	-	3	3

Components for Combinations			Free Space for Aux. Contact Blocks on Contactor		
High Speed	Low Speed	Star Contactor	High Speed K1 HN.. or HA..	Low Speed K2	Star K3
K1 Type	K2 Type	K3 Type			
K3-18ND01 + 2 x HN10	K3-18ND01 + HN10	K3-14ND10	2	3	4
K3-24A00 + HN01 + 2 x HN10	K3-24A00 + HN01 + HN10	K3-18ND10	1	2	4
K3-32A00 + HN01 + 2 x HN10	K3-32A00 + HN01 + HN10	K3-24A00 + HN10	1	2	3
K3-50A00 + HN01 + 2 x HN10	K3-50A00 + HN01 + HN10	K3-32A00 + HN10	1	2	3
K3-62A00 + HN01 + 2 x HN10	K3-62A00 + HN01 + HN10	K3-50A00 + HN10	1	2	3
K3-18ND01 + 2 x HN10	K3-18ND01 + HN10	K3-14ND10	2	3	4
K3-24A00 + HN01 + 2 x HN10	K3-24A00 + HN01 + HN10	K3-18ND10	1	2	4
K3-32A00 + HN01 + 2 x HN10	K3-32A00 + HN01 + HN10	K3-24A00 + HN10	1	2	3

Star-Delta Starters

Data according to IEC 947-4-1, VDE 0660, EN 60947-4-1

Type		K3NY15	K3NY26	K3Y40	K3Y52	K3Y80	K3Y100	K3Y140	K3Y200	K3Y240	K3Y300
Main Contacts											
Rated insulation voltage $U_i^{1)}$	V AC	690	690	690	690	690	690	690	690	690	690
Frequency of operations z	AC3, I_e 1/h					15					
Change-over time max. (Y-step)	s					20 (Type K3YL ... 60)					
Utilization category AC3											
Switching of three-phase motors											
Rated operational current I_e	220-230V A	16	30	45	60	85	109	150	205	240	300
	240V A	16	30	45	60	85	109	150	205	240	300
	380-400V A	16	30	45	60	85	109	150	205	240	300
	415-440V A	15	30	45	60	85	109	150	205	240	300
	500V A	15	30	45	60	85	95	150	205	190	240
	660-690V A	13	17	30	36	57	72	103	118	147	180
Rated operational power of three-phase motors	220-230V kW	4	7,5	11	15	22	30	45	55	75	90
	240V kW	5,5	11	15	18,5	22	30	45	55	75	90
	380-400V kW	7,5	15	22	30	45	55	75	110	132	160
	415-440V kW	7,5	15	22	30	45	55	75	110	140	170
	500V kW	7,5	18,5	30	37	55	75	90	132	132	180
	660-690V kW	11	15	22	30	45	55	90	110	132	180
Cable cross-sections											
Line	solid or stranded mm ²	1,5 - 6 ²⁾		1,5 - 16		10 - 70 ³⁾		10 - 120		busbar	
	flexible mm ²	1,5 - 4 ²⁾		1,5 - 16		16 - 50 ³⁾		10 - 95		18x5	
	flexible with multicore cable end mm ²	1,5 - 4 ²⁾		1,5 - 16		10 - 35		10 - 95		M8	
Motor	solid or stranded mm ²	1,5 - 6		1,5 - 16		4 - 35 ³⁾		10 - 120		busbar	
	flexible mm ²	1,5 - 4		1,5 - 16		6 - 25 ³⁾		10 - 95		18x5	
	flexible with multicore cable end mm ²	1,5 - 4		1,5 - 16		4 - 25		10 - 95		M8	
Power consumption of the combination											
	inrush and change-over VA	55		130		183		560		700	
	sealed VA	20		26		36		10		10	
	W	6		8		14		10		10	

Coil Voltage Ranges and Non Standard Voltages for Star-Delta Starters

K3NY15.. to K3Y100..

Suffix to Star-Delta Starter type e.g. K3Y80 400	Rated Control Voltage U_s range for 50Hz		range for 60Hz	
	min. V	max. V	min. V	max. V
24	24	24	24	27
42	42	47	47	52
110	100	110	110	122
180	180	210	200	240
230	220	240	230	264
400	380	415	400	415

K3Y140, to K3Y300..

Suffix to Star-Delta Starter type e.g. K3Y300 230	Rated Control Voltage U_s range for 50Hz		range for 60Hz		for DC V
	min. V	max. V	min. V	max. V	
24	24	24	24	24	24
48	48	48	48	48	48
110	110	120	110	120	110
230	220	240	220	240	220
400	380	415	380	415	-

Standard voltages in bold type letters

1) Suitable for: earthed-neutral systems, overvoltage category I to IV, pollution degree 3 (standard-industry): $U_{imp} = 8kV$. Data for other conditions on request.
 2) Additional terminals see page 77
 3) Maximum cable cross-section with prepared conductor

Reversing Starters

Data according to IEC 947-4-1, VDE 0660, EN 60947-4-1

Type		K3NWU10	K3NWU18	K3WU24	K3WU32	K3WU50	K3WU62	K3WU74
Main Contacts								
Rated insulation voltage $U_i^{1)}$	V AC	690	690	690	690	690	690	690
Utilization category AC3								
Switching of three-phase motors								
Rated operational current I_e								
	220V A	12	18	23	30	45	63	
	230V A	11,5	18	24	32	50	62	74
	240V A	11	18	24	32	50	62	74
	380-400V A	10	18	24	32	50	62	74
	415-440V A	9	18	23	30	50	62	74
	500V A	9	16	23	30	45	60	74
	660-690V A	6,5	8,5	17	20	31	40	40
Rated operational power of three-phase motors 50-60Hz								
	220-230V kW	3	5	6	8,5	12,5	18,5	
	240V kW	3	5	7	9	13,5	19	23
	380-400V kW	4	7,5	11	15	22	30	37
	415-440V kW	4,5	8,5	12	16	24	33	40
	500V kW	5,5	10	15	18,5	30	37	45
	660-690V kW	5,5	10	15	18,5	30	37	45
Cable cross-sections								
Line								
	solid or stranded mm ²	0,75 - 6		1,5 - 25		4 - 50		
	flexible mm ²	1 - 4		2,5 - 16		6 - 35		
	flexible with multicore cable end mm ²	0,75 - 4		1,5 - 16		6 - 35		
Cables per clamp		1		1		1		
Power consumption of the combination								
	inrush and change-over VA	33 - 45		90 - 115		140 - 185		
	sealed VA	7 - 10		9 - 13		13 - 18		
	W	2,6 - 3		2,7 - 4		5,4 - 7		

Technical Data according to UL508

Main Contacts (cULus)	Type	KNW3-10	KNW3-18	KW3-24	KW3-32	KW3-40
Rated operational power of three-phase motors at 60Hz (3ph)						
	110-120V hp	1½	2	5	5	7½
	200V hp	3	5	7½	10	10
	220-240V hp	3	7½	10	10	15
	277V hp	3	7½	7½	10	15
	380-415V hp	5	10	10	15	20
	440-480V hp	5	10	15	20	25
	550-600V hp	7½	15	20	25	30
Fuse / Short-circuit current	A/kA	30/5	50/5	90/5	125/5	175/5
Rated voltage	V	600	600	600	600	600
Auxiliary Contacts (cULus)		A600	A600	A600	A600	A600
Cable cross-sections for main connectors						
	solid AWG	18 - 10		16 - 10		
	flexible AWG	18 - 10		14 - 4		
Cables per clamp		1		1		

1) Suitable for: earthed-neutral systems, overvoltage category I to IV, pollution degree 3 (standard-industry): Uimp = 8kV. Data for other conditions on request.

Pole Changing Starters

Data according to IEC 947-4-1, VDE 0660, EN 60947-4-1

Type		K3NPU18	K3NPU24	K3PU32	K3PU50	K3PU62
Main Contacts						
Rated insulation voltage $U_i^{1)}$	V AC	690	690	690	690	690
Utilization category AC3						
Switching of three-phase motors						
Rated operational current I_e						
	220V A	18	23	30	45	63
	230V A	17,5	23	30	45	60
	240V A	17	23	30	45	60
	380-400V A	16	23	30	45	60
	415V A	16	23	30	45	60
	440V A	16	23	30	45	60
	500V A	16	23	30	45	55
	660V A	9	17,5	21	33	42
	690V A	8,5	17	20	31	40
Rated operational power of three-phase motors 50-60Hz						
	220-230V kW	5	6	8,5	12,5	18,5
	240V kW	5	7	9	13,5	19
	380-400V kW	7,5	11	15	22	30
	415-440V kW	8,5	12	16	24	33
	500V kW	10	15	18,5	30	37
	660-690V kW	7,5	15	18,5	30	37
Cable cross-sections						
Line	solid or stranded mm ²	0,75 - 6	1,5 - 25		4 - 50	
	flexible mm ²	1 - 4	2,5 - 16		6 - 35	
	flexible with multicore cable end mm ²	0,75 - 4	1,5 - 16		6 - 35	
	cables per clamp	1	1		1	
Power consumption of the combination						
	inrush and change-over VA	55	128		178	
	sealed VA	20	26		31	
	W	6	8		11	

1) Suitable for: earthed-neutral systems, overvoltage category I to IV, pollution degree 3 (standard-industry): $U_{imp} = 8kV$. Data for other conditions on request.

Star-Delta Starters

Wiring Diagrams Main Circuit

Terminal markings of contactors and relays according to DIN EN 50012
 Connections shown in main and circuits as broken lines are not included.

K3NY15 to K3Y100
 with thermal overload relay U3/.. or U12/16

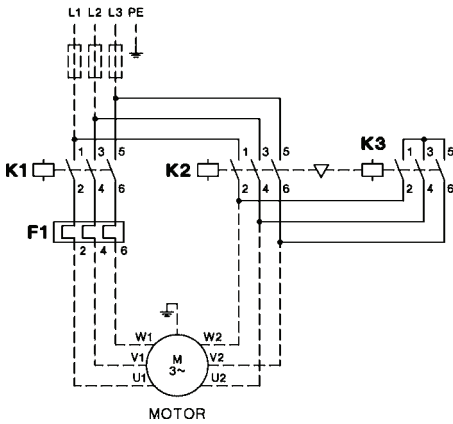

K3Y140 to K3Y300
 with thermal overload relay U85 or U180

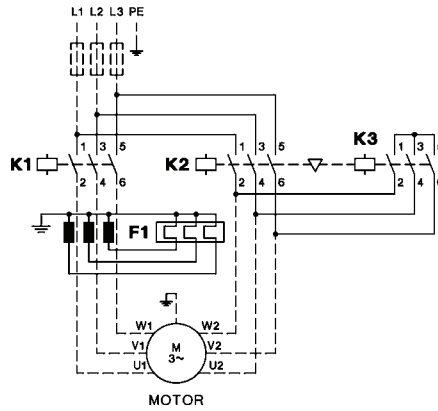

Wiring Diagrams Control Circuit

K3NY15 to K3Y52
 operating with control switch

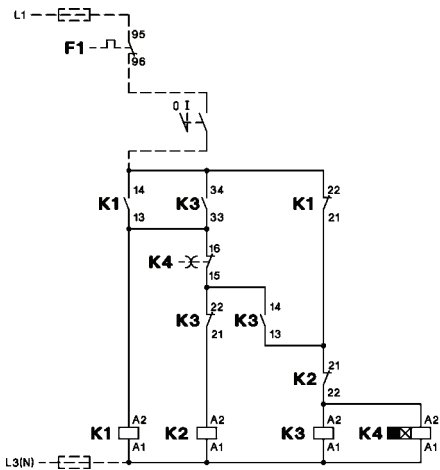

K3Y15 to K3Y52
 operating with push buttons

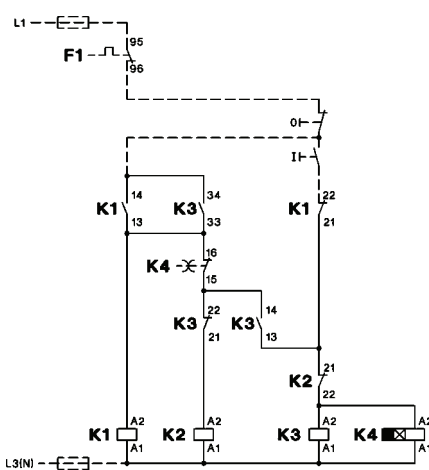

K3Y80 to K3Y200
 operating with control switch

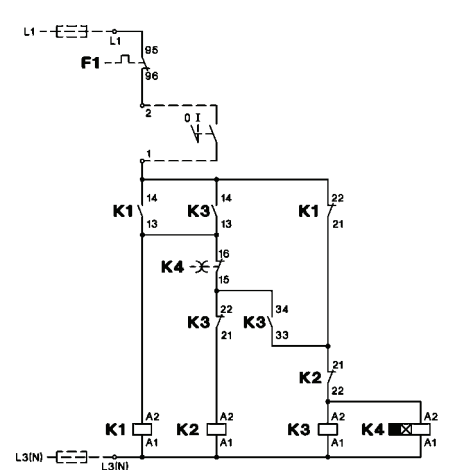

K3Y80 to K3Y200
 operating with push buttons

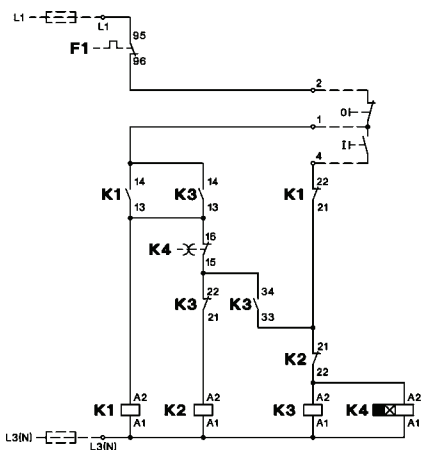

K3Y240 to K3Y300
 operating with control switch

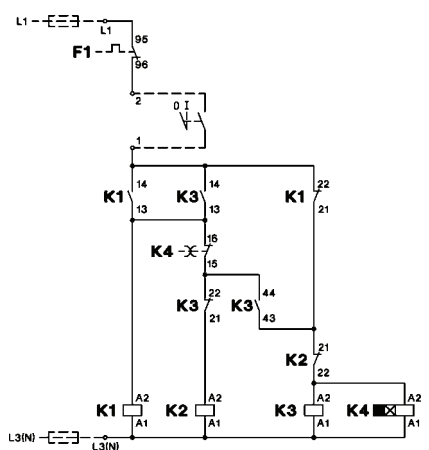

K3Y240 to K3Y300
 operating with push buttons

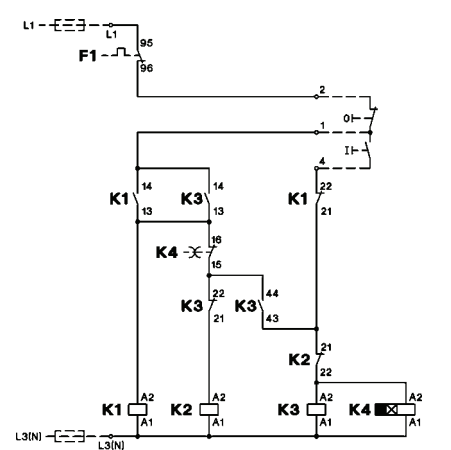

Star-Delta Starters

Wiring Diagrams Main Circuit

Terminal markings of contactors and relays according to DIN EN 50012
 Connections shown in main and control circuits as broken lines are not included.

K3YL..
 Typical circuit diagram

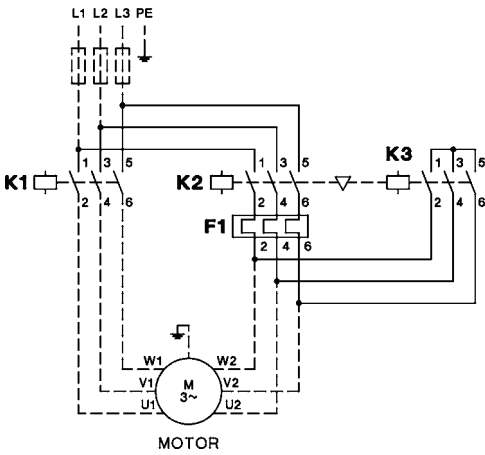

K3Y.. with 2 Thermal Overload Relays
 Typical circuit diagram

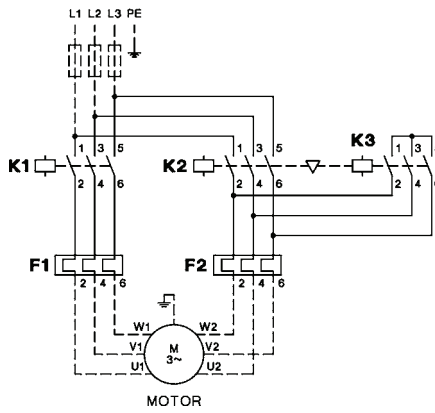

Wiring Diagrams Control Circuit

with selector switch
 K3Y..W
 Typical circuit diagram
 operating with control switch

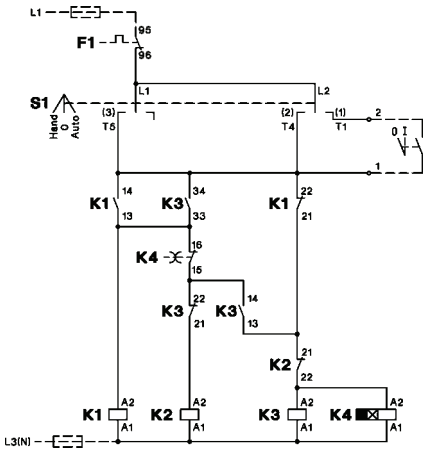

Typical circuit diagram
 operating with push buttons

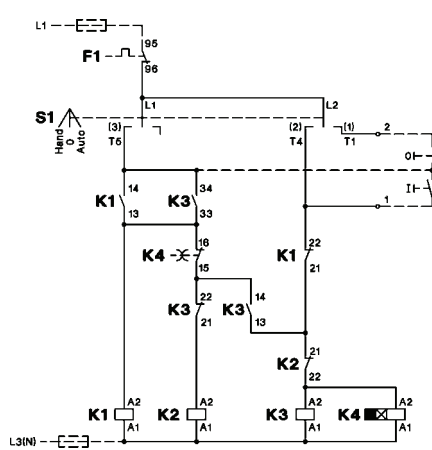

with push buttons
 K3Y..T
 Typical circuit diagram

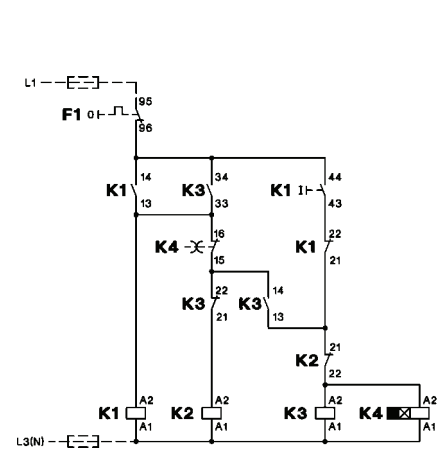

Reversing Contactors

Wiring Diagrams Main Circuit

Terminal markings of contactors and relays according to DIN EN 50012
 Connections shown in main and control circuits as broken lines are not included.

K3NWU10 to K3WU74
 with thermal overload relay U3/32, U3/42 or U3/74

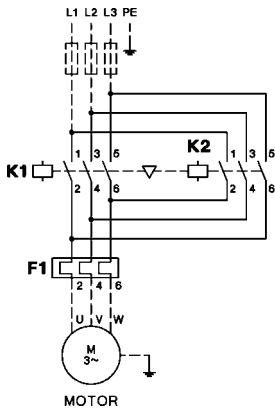

Wiring Diagrams Control Circuit

K3NWU10 to K3WU32
 operating with control switch

operating with push buttons
 Reversing over off-position

Reversing direct

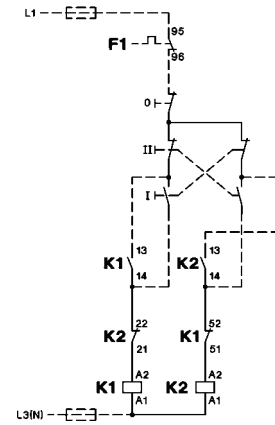
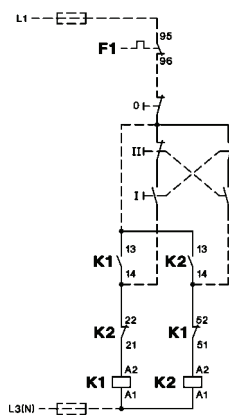
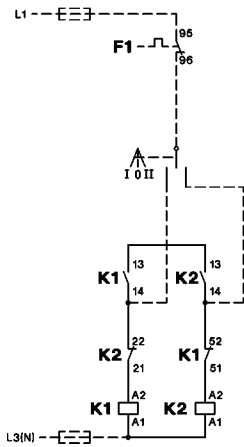

K3WU50, K3WU62, K3WU74
 operating with control switch

operating with push buttons

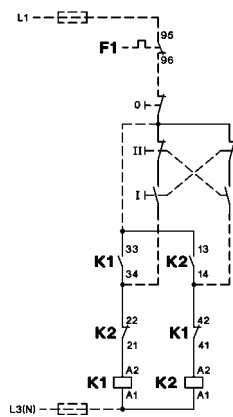
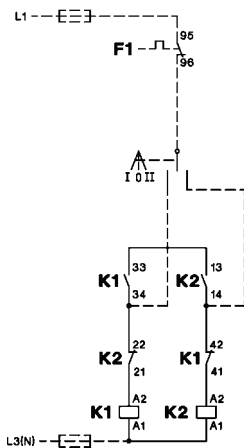

Pole Changing Starters

Wiring Diagrams

Terminal markings of contactors and relays according to DIN EN 50012
 Connections shown in main and control circuits as broken lines are not included.

Main Circuit

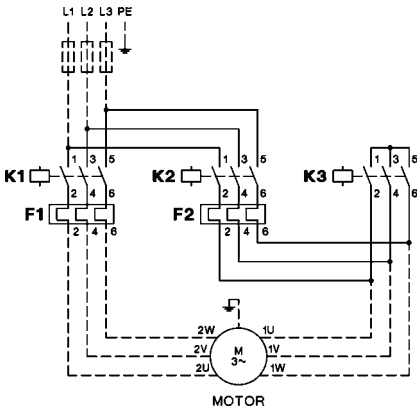

Principal Control Circuit Wiring Diagram operating with control switch

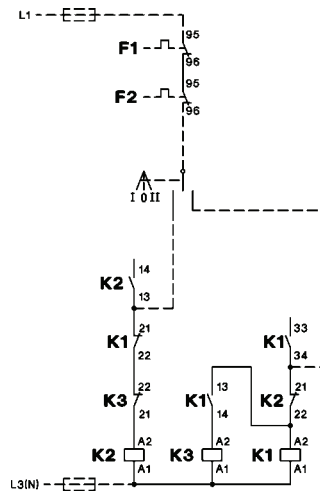

operating with push buttons

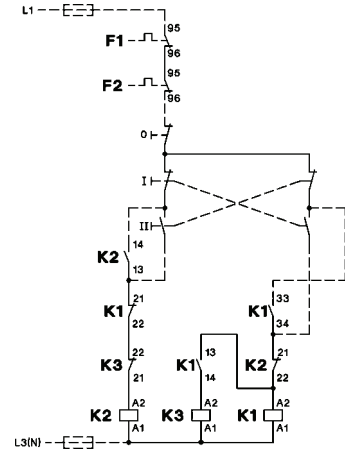

	Low speed	High speed
Operation	Delta	Double-Star
Speed relation	1	2
Power relation	1	1,5 - 1,8

	Low speed	High speed
Operation	Star	Double-Star
Speed relation	1	2
Power relation	0,3	1

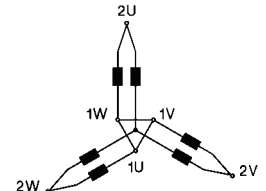
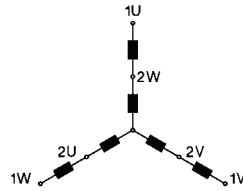
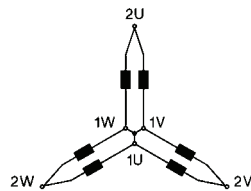
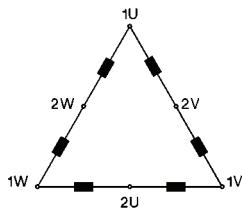

Star-Delta Starters

Dimensions

Star-Delta Starters, AC operated, open type

K3NY15 + U3/32
K3NY26

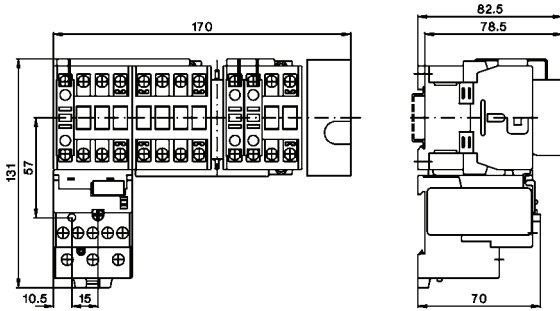

K3NY15 + U12/16E G3
K3NY26

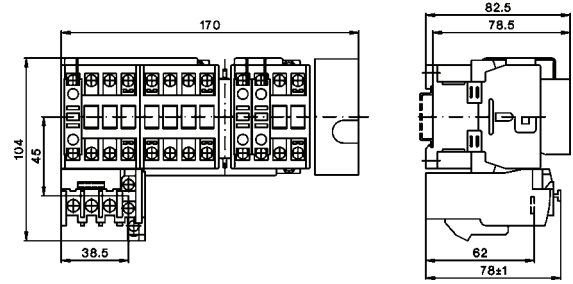

K3Y40 + U3/32
K3Y52 + U3/32

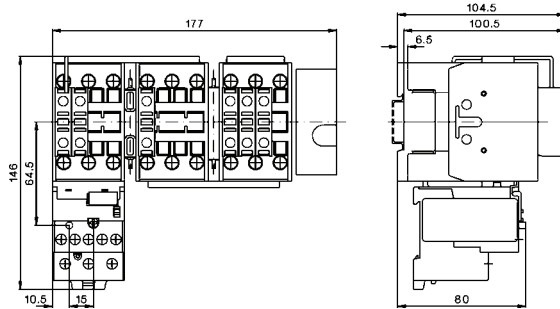

K3Y40 + U3/42
K3Y52 + U3/42

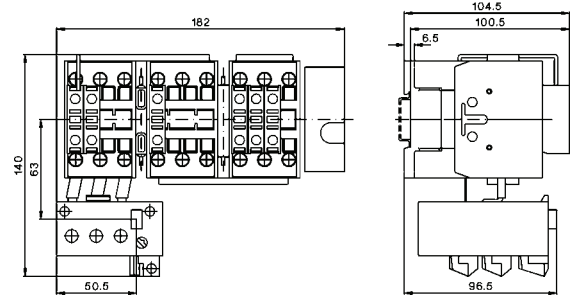

K3Y80 + U3/74

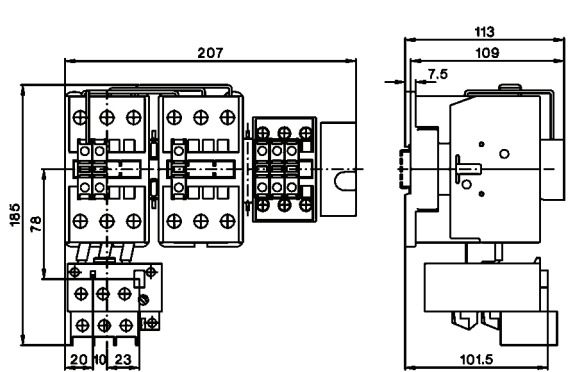

K3Y100 + U3/74

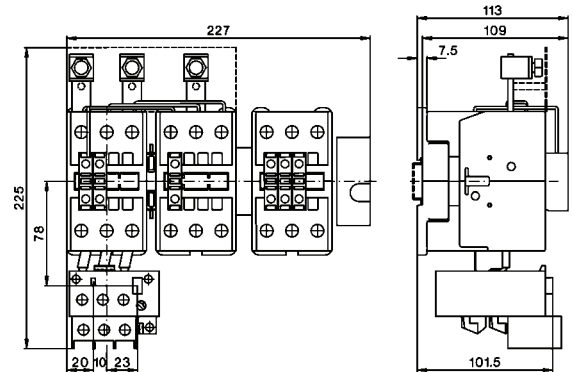

K3Y140 + U85
K3Y200

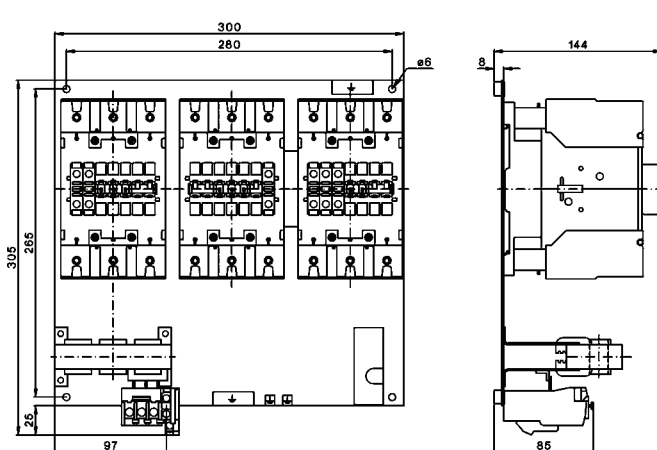

K3Y240 + U180 + SU180/176
K3Y300

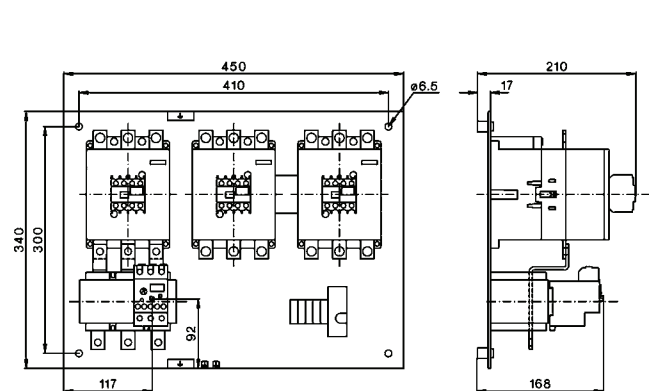

Star-Delta Starters

Dimensions

Star-Delta Starters, plastic enclosed, protected to IP65

K3NY26P

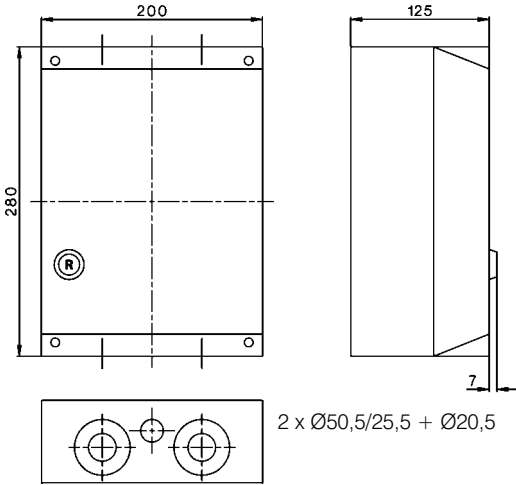

K3Y40P to K2Y100P

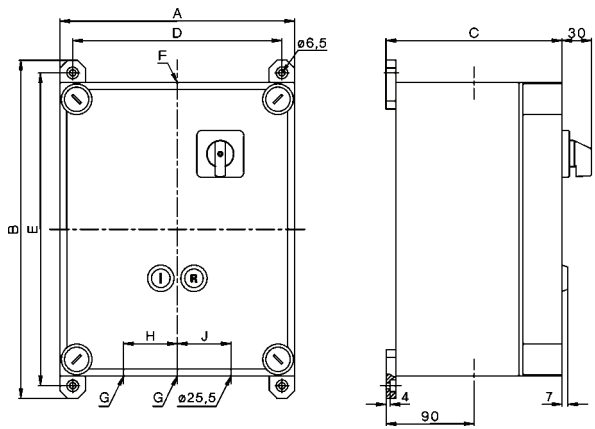

Type	A	B	C	D	E	Ø F	Ø G	H	J	
K3Y40P	300	346	180	272	320	6,5	32,5	32,5	60	60
K3Y52P	300	346	180	272	320	6,5	32,5	32,5	60	60
K3Y80P	300	446	180	272	420	6,5	40,5	40,5	70	70
K3Y100P	300	446	180	272	420	6,5	50,5	40,5	70	70

Star-Delta Starters, sheet steel enclosed, protected to IP54

K3Y26B to K3Y52B

Type	Ø F	Ø G
K3NY26B	25,5	25,5
K3Y40B	32,5	32,5
K3Y52B	32,5	32,5

Mounting by included fixing link

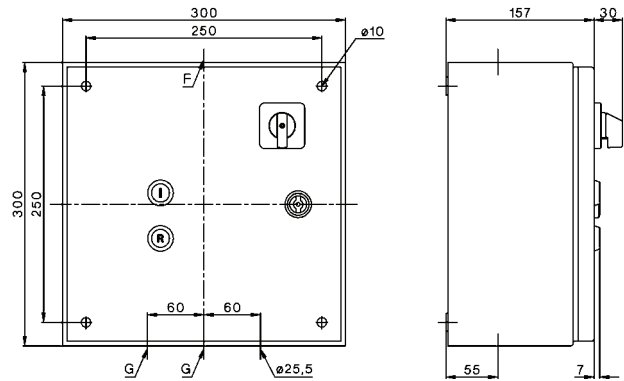
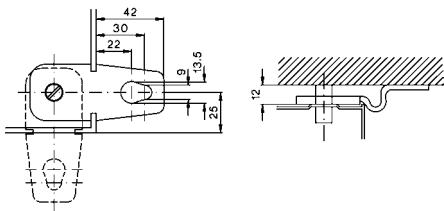

K3Y80B to K2Y200B

Type	A	B	C	D	E	L	M
K3Y80B	380	380	210	340	340	8,7	65
K3Y100B	380	380	210	340	340	8,7	65
K3Y140B	380	600	210	560	340	8,7	65
K3Y200B	380	600	210	560	340	8,7	65

Type	Ø F	Ø G	H	J	K
K3Y80B	40,5	40,5	70	70	60
K3Y100B	50,5	40,5	80	70	60
K3Y140B	50,5	50,5	80	80	70
K3Y200B	50,5	50,5	80	80	70

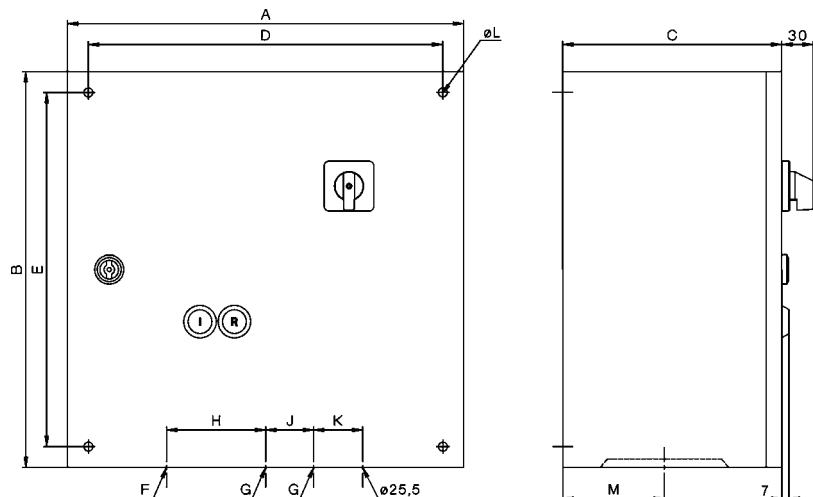

Reversing Contactors

Dimensions

Reversing Starters, AC operated, open type

K3NWU10 + U3/32
K3NWU18

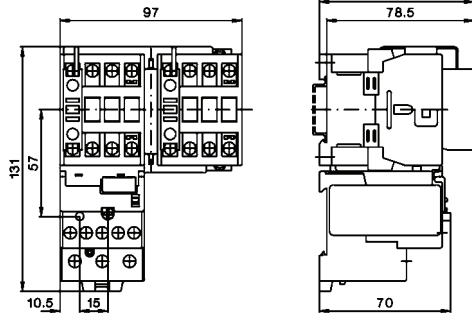

K3NWU10 + U12/16E G3
K3NWU18

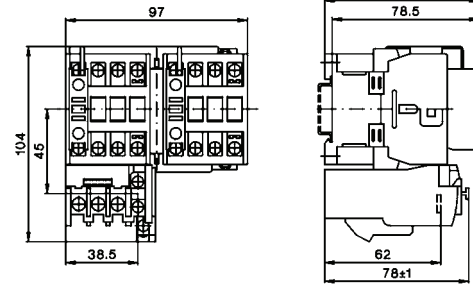

K3WU24 + U3/32
K3WU32
K3WU40

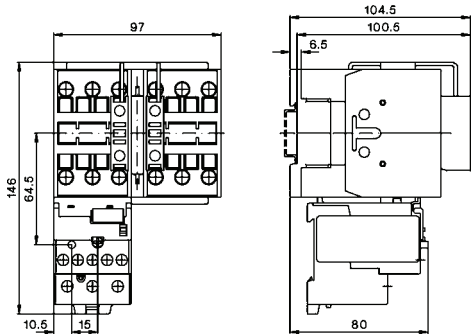

K3WU24 + U3/42
K3WU32
K3WU40

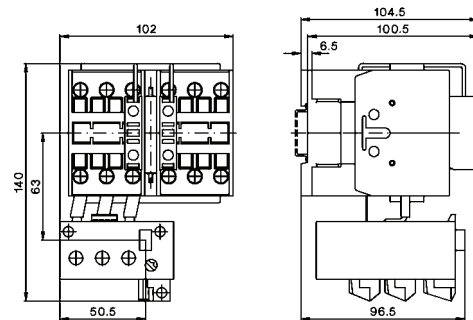

K3WU50 + U3/74
K3WU62
K3WU74

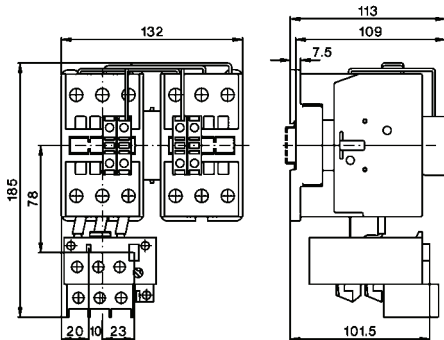

Reversing Contactors, sheet steel enclosed, protected to IP54

Type	A	B	C	D	E	F	G	H	K
K3NWU18B	300	300	150	250	250	30	30	Ø25,5	41
K3WU24B	300	300	150	250	250	30	30	Ø32,5	41
K3WU32B	300	300	150	250	250	30	30	Ø32,5	41
K3WU50B	300	300	150	250	250	40	40	Ø32,5	59
K3WU62B	300	300	150	250	250	40	40	Ø32,5	59

Mounting by included fixing link

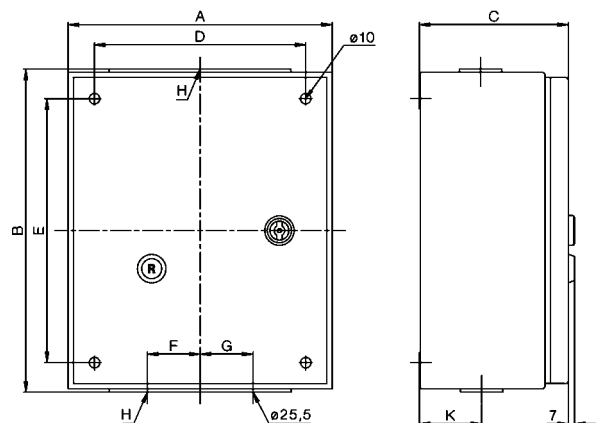
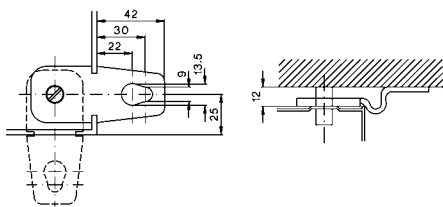

Pole Changing Starters

Dimensions

Pole Changing Starters, AC operated, open type

K3NPU18 + 2x U3/32

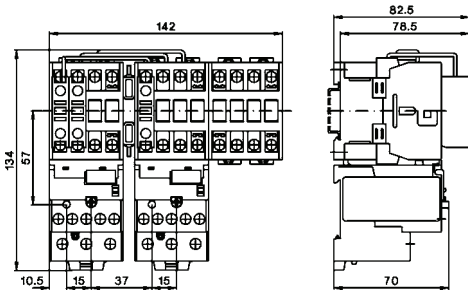

K3NPU18 + 2x U12/16

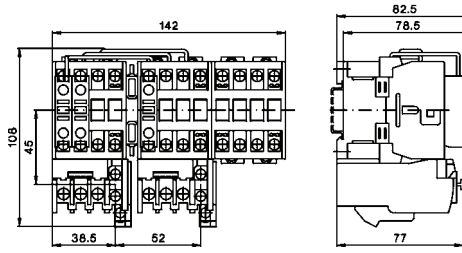

K3PU24 + 2x U3/32
K3PU32

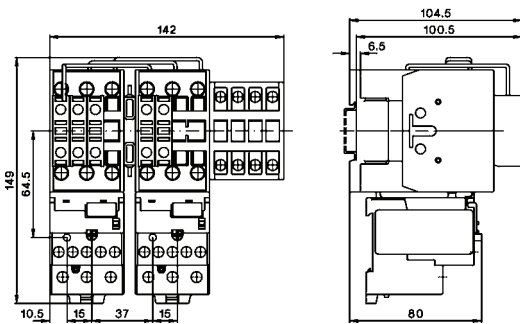

K3PU50 + 2x U3/74
K3PU62

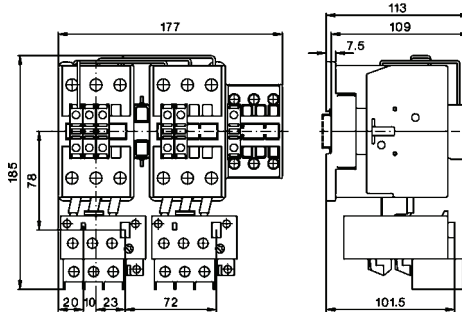

Pole Changing Starters, sheet steel enclosed, protected to IP54

K3NPU18B to K3PU32B

Type	Ø F	Ø G
K3NPU18B	25,5	25,5
K3PU24B	32,3	32,5
K3PU32B	32,3	32,5

Mounting by included fixing link

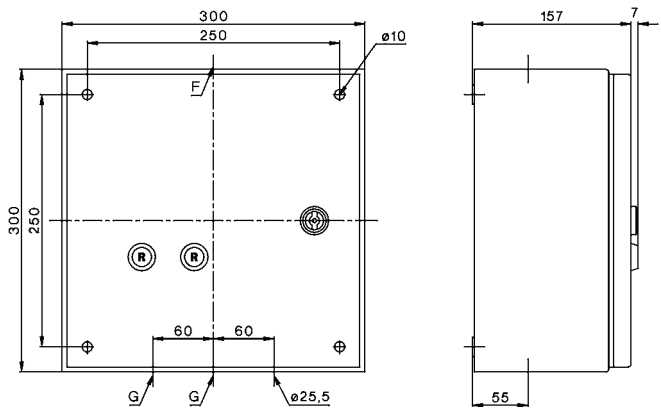
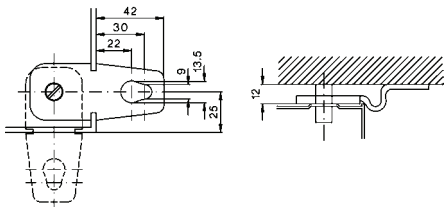



D.O.L. Starters With Start-Stop Buttons

94



D.O.L. Starters With Selector Switch

94



D.O.L. Starters With Selector Switch And Pneumatic Switch For Use In Moist Rooms

94



Enclosures

95



Accessories

95

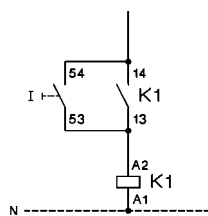

Wiring Diagrams

96

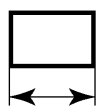

Dimensions

98

D.O.L. Starters In Plastic Enclosure

Ratings	Included	Free	Wired	Protec-	Conduit	Type	Coil voltage ¹⁾	Pack	Weight
AC3 at	Contactors	Space	to	tion	Entries			pcs.	kg/pc.
380V		f. Aux.	accept	Degree			220-240V 50Hz 230-264V 60Hz		
400V		Cont.	Overload				380-415V 50Hz 400-440V 60Hz		
415V		HN..	Relay						
kW	Type	pcs.	Type						

D.O.L. Starters with Start-Stop/Reset Push Buttons



4	K3-10ND10	2	U12/16 K3	IP65	Ø 20,5mm	P1T10 ...	1	0,6
7,5	K3-18ND10	2	U12/16 K3	IP65	Ø 20,5mm	P1T18 ...	1	0,6
11	K3-22ND10	2	U12/16 K3	IP65	Ø 20,5mm	P1T22 ...	1	0,6

D.O.L. Starters with Selector Switch



4	K3-10ND10	2	U12/16 K3	IP65	Ø 20,5mm	P1W10 ...	1	0,6
7,5	K3-18ND10	2	U12/16 K3	IP65	Ø 20,5mm	P1W18 ...	1	0,6
11	K3-22ND10	2	U12/16 K3	IP65	Ø 20,5mm	P1W22 ...	1	0,6

D.O.L. Starters with Selector Switch and Pneumatic Switch for moist rooms



7,5	K3-18ND10	2	U12/16 K3	IP65	Ø 20,5mm	P1W18P ...	1	0,6
------------	-----------	---	-----------	------	----------	-------------------	---	-----

Push button and tube on request

Ordering Example: D.O.L. Starter with selector switch, plastic enclosed, rated AC3 at 400V 15,5A, rated control voltage 230V 50Hz - **Order Type: P1W18 230 + U12/16E 18 K3**

Thermal Overload Relays



Setting range	Type	Pack	Weight
A		pcs.	kg/pc.
0,12 - 0,18	U12/16E 0,18 K3	1	0,10
0,18 - 0,27	U12/16E 0,27 K3	1	0,10
0,27 - 0,4	U12/16E 0,4 K3	1	0,10
0,4 - 0,6	U12/16E 0,6 K3	1	0,10
0,6 - 0,9	U12/16E 0,9 K3	1	0,10
0,8 - 1,2	U12/16E 1,2 K3	1	0,10
1,2 - 1,8	U12/16E 1,8 K3	1	0,10
1,8 - 2,7	U12/16E 2,7 K3	1	0,10
2,7 - 4	U12/16E 4 K3	1	0,10
4 - 6	U12/16E 6 K3	1	0,10
6 - 9	U12/16E 9 K3	1	0,10
8 - 11	U12/16E 11 K3	1	0,10
10 - 14	U12/16E 14 K3	1	0,10
13 - 18	U12/16E 18 K3	1	0,10
17 - 23	U12/16E 23 K3	1	0,10
22 - 30	U12/16E 30 K3	1	0,13

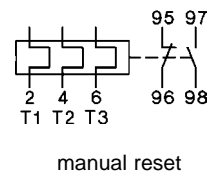

Overload Relays with Quick Tripping Characteristic see page 103

Technical data see contactors page 44 and thermal overload relays page 107

1) Non-standard coil voltages see page 39

Enclosures for Contactors



Suitable for contactor	Protection Degree	Conduit Entries		Type	Pack pcs.	Weight kg/pc.
		Top	Bottom			
K3-07.. to K3-22.. K3-24.. ¹⁾ to K3-40.. ¹⁾	IP65	2 x Ø 20,5mm	2 x Ø 20,5mm	P1	1	0,35

Enclosures for D.O.L. Starters with reset button



Suitable for contactor	Protection Degree	Conduit Entries		Type	Pack pcs.	Weight kg/pc.
		Top	Bottom			
K3-10.. to K3-22.. +U12/16.. K3	IP65	2 x Ø 20,5mm	2 x Ø 20,5mm	P1R	1	0,35

Indicator Units



Specifications	Voltage Range	Type	Pack pcs.	Weight kg/pc.
Coil Current Indicator , green (LED)	24 - 660V AC/DC	K2-ING	10	0,02
Coil Current Indicator , red (LED)	24 - 660V AC/DC	K2-INR	10	0,02
To be connected in series with the contactor coil. In case of coil interruption the indicator goes out. Voltage drop approx. 2 volts				
Voltage Indicator , clear (glow-disc. I.)	220 - 415V AC/DC	K2-UN	10	0,02
Voltage Indicator , red (LED)	24 - 120V AC/DC	K2-UNR	10	0,02
To be connected parallel to the contactor coil. In case of applied voltage the indicator also lights at coil interruption.				
Lens Caps For Indicator Units				
Lens cap transparent		LG9743T	10	0,005
Lens cap red		LG9743R	10	0,005
Lens cap green		LG9743GR	10	0,005
Mounting instructions see page 100				

Heating Element



Specifications	Voltage Range	Type	Pack pcs.	Weight kg/pc.
	Power Consumption			
To avoid condensed water on places where high humidity is given together with alterations of ambient temperature	380 - 415V, 1,5W	K2-HR	10	0,02
	220 - 240V, 1,5W	K2-HR 230	10	0,02

Additional Terminals, Start Contact



Specification	Cable Cross-sections to clamp mm ²			Type	Pack pcs.	Weight kg/pc.
	solid or stranded	flexible	flexib. w. multi-core cable end			
Neutral Terminal	2 x 0,75-4	2 x 0,75-2,5	2 x 0,5-2,5	LG9744	10	0,009
Earth Terminal	2,5-16	1,5-10	1,5-10	LG9750	10	0,052
Mounting instructions see page 100						
Start Contact	for contactor K3-10 to K3-22	to be snapped on top of the auxiliary contact		LG9319-K3	10	0,03

¹⁾ without auxiliary contact blocks

D.O.L. Starters

Wiring Diagrams Main Circuit

All fuses F0 shown in the main circuits are not included.
Terminal markings according to EN 50012

P1...
with overload relay U12/16.. K3

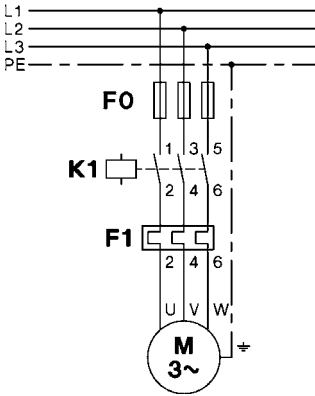

Wiring for single phase motors

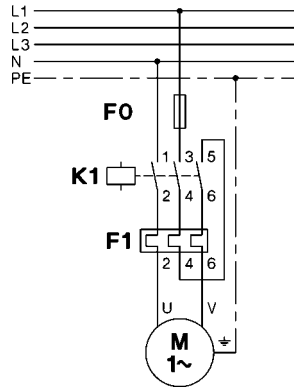

Wiring Diagrams Control Circuit

D.O.L. Starters P1 with standard coil voltages (see page 94) are supplied with connectors between main circuit and control circuit.

Coil connectors

Coils for **380-415V 50Hz** and **400-440V 60Hz**: The starter is supplied with control circuit connectors between terminals 1 (L1) and 5 (L3).
Coils for **220-240V 50Hz** and **230-264V 60Hz**: The starter is supplied with control circuit connectors between terminals 95 and 5 (L3). Connect neutral wire to terminal A1.
Coils for **other voltages**: Without connectors between supply and control circuit. Connect supply to terminals A1 and 95.

Separate coil supply

Coils for **380-415V 50Hz** and **400-440V 60Hz**: Remove connectors A1-1 and 95-5, connect supply to terminals A1 and 95.
Coils for **220-240V 50Hz** and **230-264V 60Hz**: Remove connectors 95-5 connect supply to terminals A1 and 95.
Coils for **other voltages**: Connect supply to terminals A1 and 95.

Coil phase to phase (380-415V 50Hz)

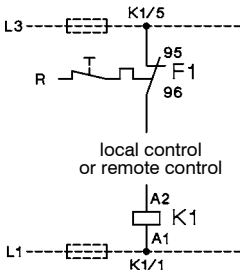

Coil phase to neutral (220-240V 50Hz)

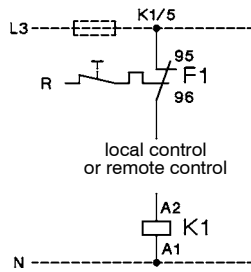

Coil phase to phase

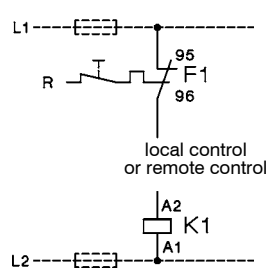

Coil phase to neutral

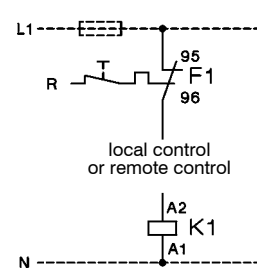

D.O.L. Starters with remote control

P1..
Remote 2-wire (switch) control

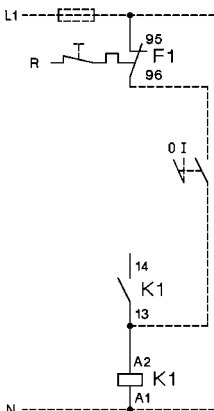

Remote 3-wire (push button) control

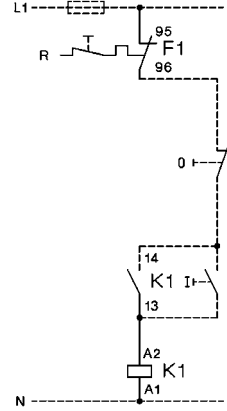

Remote start-stop control
(3 control stations)

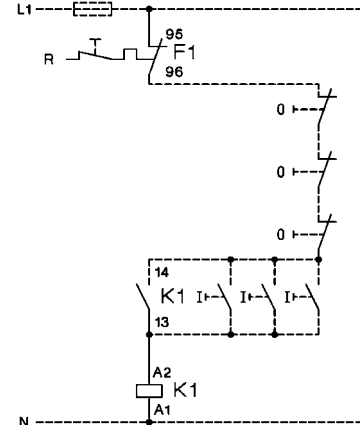

D.O.L. Starters

Wiring Diagrams Control Circuits

Typical circuit diagram (for separate coil supply, control circuit connected between L1 and N)
Terminal markings according to EN 50012

D.O.L. Starters with Start-Stop/Reset Push Buttons

P1T10, P1T18, P1T22
with overload relay U12/16.. K3

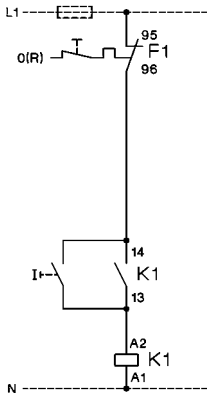

P1T10, P1T18, P1T22
with external push buttons

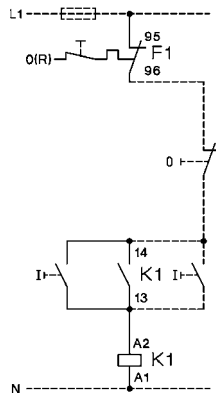

D.O.L. Starters with Selector Switch

P1W10, P1W18, P1W22
with external control switch

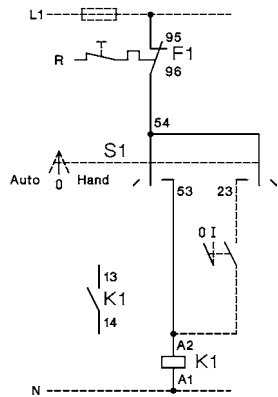

P1W10, P1W18, P1W22
with external push buttons

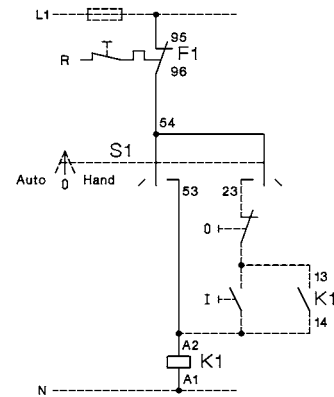

D.O.L. Starters with Selector Switch and Pneumatic Switch for Swimmingpool Control Gear and for use in Moist Rooms

P1W18P
with overload relay U12/16.. K3

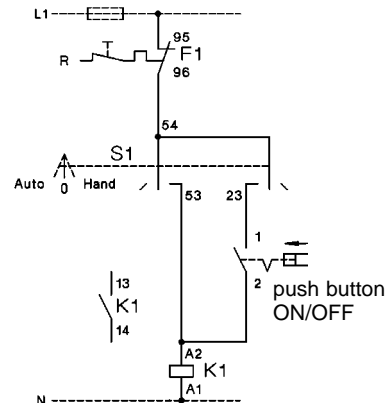

D.O.L. Starters

Dimensions

D.O.L. Starters with Start-Stop/Reset Push Buttons, Plastic Enclosed

P1T..., P1TP..

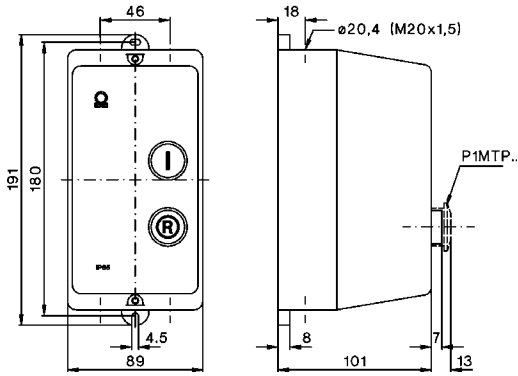

D.O.L. Starters with Selector Switch, Plastic Enclosed

P1W..., P1W18P

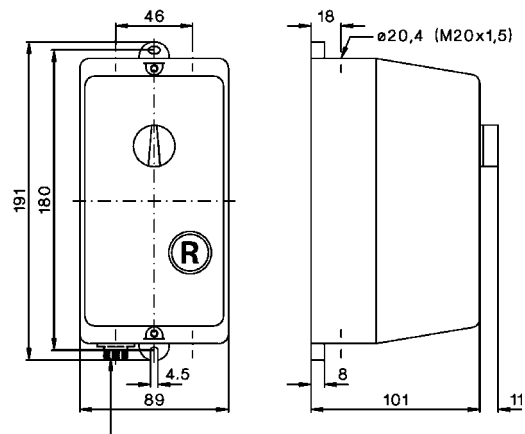

P1W18P: plug-in for air tube inside diameter 3mm

Rear Conduit Entries

knockouts
4 x Ø 23

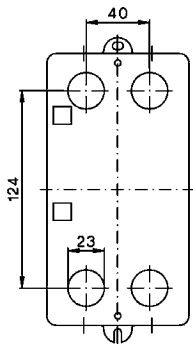

Enclosures

Dimensions

Enclosures for Contactors

P1

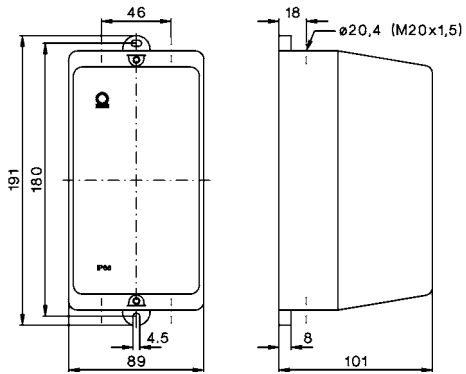

Enclosures for D.O.L. Starters

P1R, P1P

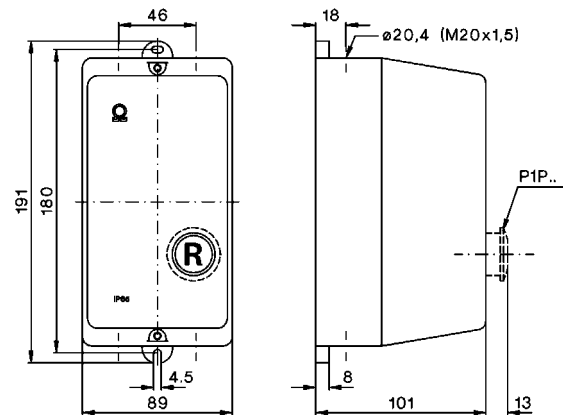

Rear Conduit Entries

knockouts
4 x $\phi 23$

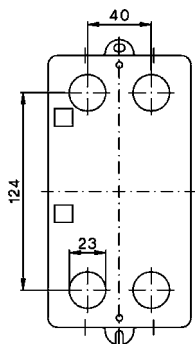

D.O.L. Starters

Mounting and Wiring Instructions

Indicators and Lens Caps for D.O.L. Starters P1

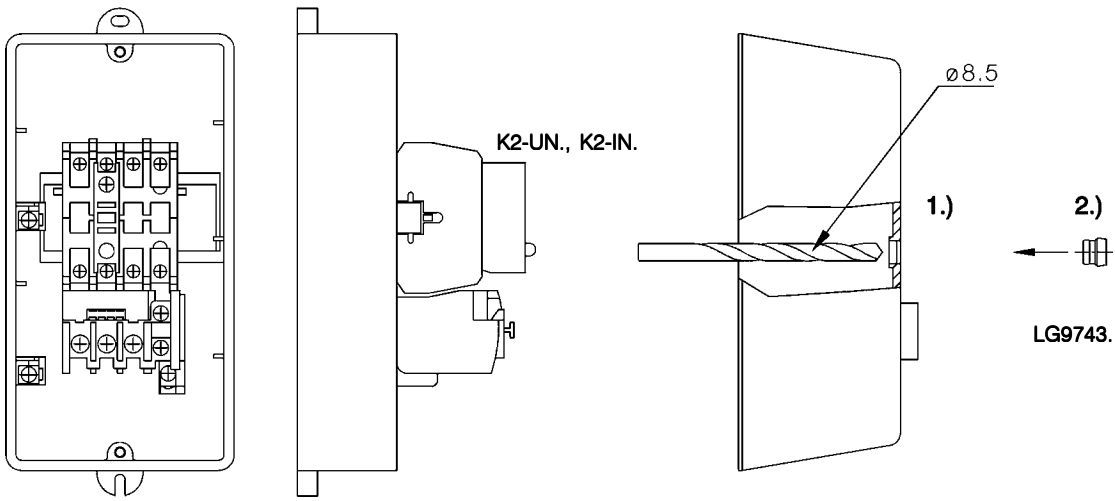

Wiring Examples

Coil Current Indicator

K2-ING
K2-INR

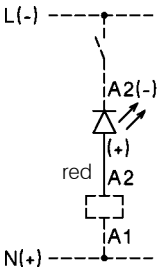

Voltage Indicator

K2-UN
K2-UNR

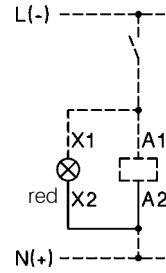

Heating Element

K2-HR

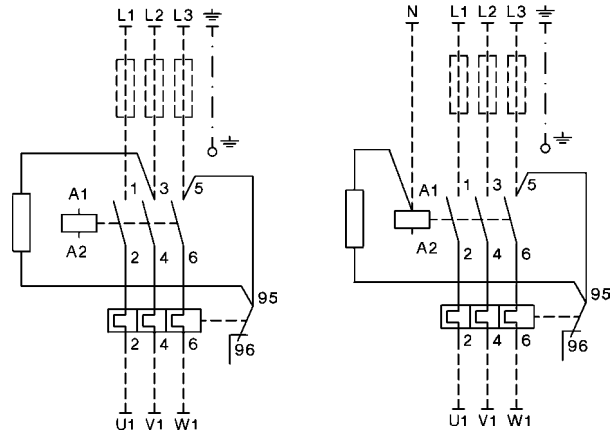

K2-HR 230

Colour mentioned in wiring diagrams refer to the outgoing connection wire of the device.

Earth Terminal LG9750 for K2-23 and K2-30 in Enclosure P1

for K2-23 and K2-30 remove spacing piece

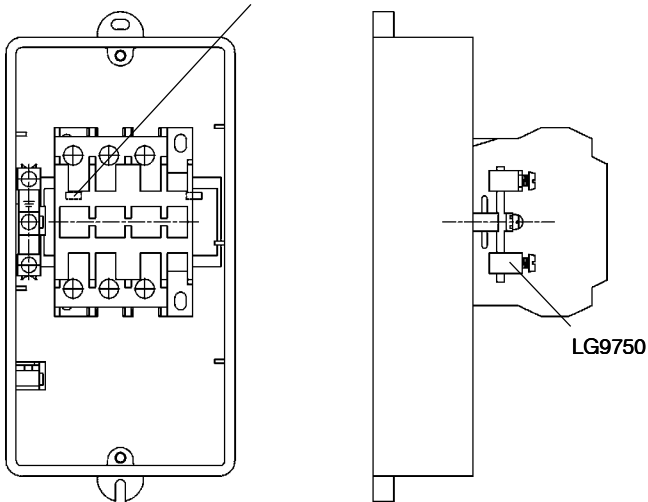

Neutral Terminal LG9744

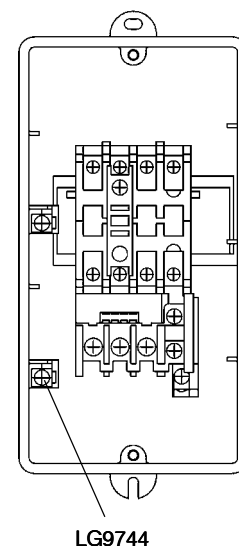



Thermal Overload Relays for Direct Mounting

102



Thermal Overload Relays for Separate Mounting

104



Accessories

105



Technical Data

106

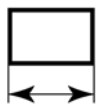

Dimensions

111

Thermal Overload Relays for plug-in mounting

Setting Range
D.O.L. (A) Δ (A)

Type

Pack pcs. Weight kg/pc. Wiring Diagram

With Manual Reset, for contactors K1-..

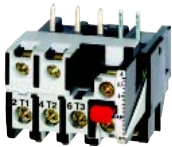

0,12 - 0,18	-		U12/16E 0,18 K1	1	0,10
0,18 - 0,27	-		U12/16E 0,27 K1	1	0,10
0,27 - 0,4	-		U12/16E 0,4 K1	1	0,10
0,4 - 0,6	-		U12/16E 0,6 K1	1	0,10
0,6 - 0,9	-		U12/16E 0,9 K1	1	0,10
0,8 - 1,2	-		U12/16E 1,2 K1	1	0,10
1,2 - 1,8	-		U12/16E 1,8 K1	1	0,10
1,8 - 2,7	-		U12/16E 2,7 K1	1	0,10
2,7 - 4	-		U12/16E 4 K1	1	0,10
4 - 6	7 - 10,5		U12/16E 6 K1	1	0,10
6 - 9	10,5 - 15,5		U12/16E 9 K1	1	0,10
8 - 11	14 - 19		U12/16E 11 K1	1	0,10
10 - 14	18 - 24		U12/16E 14 K1	1	0,10

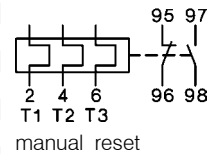

With Auto Reset, for contactors K1-..

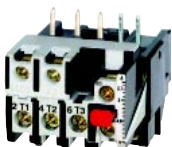

0,12 - 0,18	-		U12/16A 0,18 K1	1	0,10
0,18 - 0,27	-		U12/16A 0,27 K1	1	0,10
0,27 - 0,4	-		U12/16A 0,4 K1	1	0,10
0,4 - 0,6	-		U12/16A 0,6 K1	1	0,10
0,6 - 0,9	-		U12/16A 0,9 K1	1	0,10
0,8 - 1,2	-		U12/16A 1,2 K1	1	0,10
1,2 - 1,8	-		U12/16A 1,8 K1	1	0,10
1,8 - 2,7	-		U12/16A 2,7 K1	1	0,10
2,7 - 4	-		U12/16A 4 K1	1	0,10
4 - 6	7 - 10,5		U12/16A 6 K1	1	0,10
6 - 9	10,5 - 15,5		U12/16A 9 K1	1	0,10
8 - 11	14 - 19		U12/16A 11 K1	1	0,10
10 - 14	18 - 24		U12/16A 14 K1	1	0,10

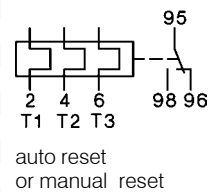

With Quick Tripping Characteristic for EEx e motors and submersible pumps, f. contactors K1-..

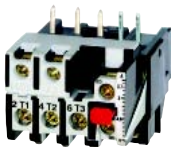

0,4 - 0,6	-		U12/16EQ 0,6 K1	1	0,10
0,6 - 0,9	-		U12/16EQ 0,9 K1	1	0,10
0,8 - 1,2	-		U12/16EQ 1,2 K1	1	0,10
1,2 - 1,8	-		U12/16EQ 1,8 K1	1	0,10
1,8 - 2,7	-		U12/16EQ 2,7 K1	1	0,10
2,7 - 4	-		U12/16EQ 4 K1	1	0,10
4 - 6	7 - 10,5		U12/16EQ 6 K1	1	0,10
6 - 9	10,5 - 15,5		U12/16EQ 9 K1	1	0,10
8 - 11	14 - 19		U12/16EQ 11 K1	1	0,10
10 - 14	18 - 24		U12/16EQ 14 K1	1	0,10

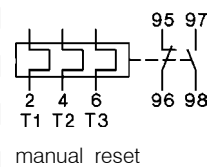

Thermal Overload Relays for plug-in mounting

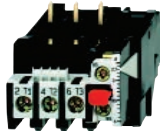

Setting Range
D.O.L. (A) Δ (A)

Type

Pack Weight
pcs. kg/pc.

Wiring Diagram

With Manual Reset, for contactors K(G)3-10.. to K(G)3-22.. ..

0,12 - 0,18	-		U12/16E 0,18 K3	1	0,10
0,18 - 0,27	-		U12/16E 0,27 K3	1	0,10
0,27 - 0,4	-		U12/16E 0,4 K3	1	0,10
0,4 - 0,6	-		U12/16E 0,6 K3	1	0,10
0,6 - 0,9	-		U12/16E 0,9 K3	1	0,10
0,8 - 1,2	-		U12/16E 1,2 K3	1	0,10
1,2 - 1,8	-		U12/16E 1,8 K3	1	0,10
1,8 - 2,7	-		U12/16E 2,7 K3	1	0,10
2,7 - 4	-		U12/16E 4 K3	1	0,10
4 - 6	7 - 10,5		U12/16E 6 K3	1	0,10
6 - 9	10,5 - 15,5		U12/16E 9 K3	1	0,10
8 - 11	14 - 19		U12/16E 11 K3	1	0,10
10 - 14	18 - 24		U12/16E 14 K3	1	0,10
13 - 18	23 - 31		U12/16E 18 K3	1	0,10
17 - 23	30 - 40		U12/16E 23 K3	1	0,10
22 - 30	38 - 52		U12/16E 30 K3	1	0,13

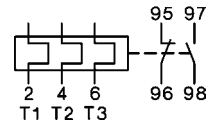

manual reset

Mit flinker Auslösecharakteristik für EEx e Motoren und Unterwasserpumpen



0,4 - 0,6	-		U12/16EQ 0,6 K3	1	0,10
0,6 - 0,9	-		U12/16EQ 0,9 K3	1	0,10
0,8 - 1,2	-		U12/16EQ 1,2 K3	1	0,10
1,2 - 1,8	-		U12/16EQ 1,8 K3	1	0,10
1,8 - 2,7	-		U12/16EQ 2,7 K3	1	0,10
2,7 - 4	-		U12/16EQ 4 K3	1	0,10
4 - 6	7 - 10,5		U12/16EQ 6 K3	1	0,10
6 - 9	10,5 - 15,5		U12/16EQ 9 K3	1	0,10
8 - 11	14 - 19		U12/16EQ 11 K3	1	0,10
10 - 14	18 - 24		U12/16EQ 14 K3	1	0,10

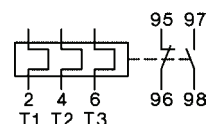

manual reset

For contactors K(G)3-10.. to K(G)3-40A..



0,12 - 0,18	-		U3/32 0,18	1	0,14
0,18 - 0,27	-		U3/32 0,27	1	0,14
0,27 - 0,4	-		U3/32 0,4	1	0,14
0,4 - 0,6	-		U3/32 0,6	1	0,14
0,6 - 0,9	-		U3/32 0,9	1	0,14
0,8 - 1,2	-		U3/32 1,2	1	0,14
1,2 - 1,8	-		U3/32 1,8	1	0,14
1,8 - 2,7	-		U3/32 2,7	1	0,14
2,7 - 4	-		U3/32 4	1	0,14
4 - 6	7 - 10,5		U3/32 6	1	0,14
6 - 9	10,5 - 15,5		U3/32 9	1	0,14
8 - 11	14 - 19		U3/32 11	1	0,14
10 - 14	18 - 24		U3/32 14	1	0,14
13 - 18	23 - 31		U3/32 18	1	0,14
17 - 24	30 - 41		U3/32 24	1	0,14
23 - 32	40 - 55		U3/32 32	1	0,14

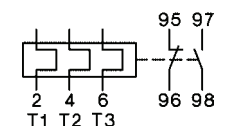

manual and auto reset

For contactors K(G)3-24A.. to K(G)3-40A ..



10 - 14	18 - 24		U3/42 14	1	0,30
14 - 20	24 - 35		U3/42 20	1	0,30
20 - 28	35 - 48		U3/42 28	1	0,30
28 - 42	48 - 73		U3/42 42	1	0,30

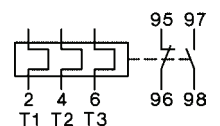

manual and auto reset

Thermal Overload Relays for plug-in mounting



Setting Range		Type	Pack pcs.	Weight kg/pc.	Wiring Diagram
D.O.L. (A)	Δ (A)				
For contactors K3-50A.. to K3-74A..					
20 - 28	35 - 48	U3/74 28	1	0,40	
28 - 42	48 - 73	U3/74 42	1	0,40	
40 - 52	70 - 90	U3/74 52	1	0,40	
52 - 65	90 - 112	U3/74 65	1	0,40	manual and auto reset
60 - 74	104 - 128	U3/74 74	1	0,40	

Thermal Overload Relays for separate mounting

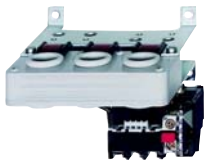

Setting Range		Type	Pack pcs.	Weight kg/pc.	Wiring Diagram
D.O.L. (A)	Δ (A)				
For contactors K3-90, K3-115, K85, K110					
60 - 90	104 - 156	U85 90	1	0,90	
80 - 120	140 - 207	U85 120			
For contactors K3-151.. and K3-176.., busbars included					
120 - 180	208 - 312	U180 180	1	1,5	
For contactors K3-210.. up to K3-316.., busbars included					
144 - 216	250 - 374	U320 216	1	1,8	manual and auto reset
216 - 320	374 - 554	U320 320			
For contactors K3-315.. , K3-450.. , K3-550.. , K3-700.. , K3-860..					
240 - 360	416 - 623	U800 360	1	4,1	
360 - 540	623 - 935	U800 540	1	4,1	
540 - 800	935 - 1385	U800 800	1	4,1	



With Slow Tripping Characteristic for heavy duty starting with long run up times

For separate mounting, suitable for all contactors



0,8 - 1,2	1,2 - 2,1	UAT21 1,2	1	1,0	
1,2 - 1,8	2,1 - 3,1	UAT21 1,8	1	1,0	
1,6 - 2,4	2,8 - 4,2	UAT21 2,4	1	1,0	
2,4 - 3,7	4,2 - 6,4	UAT21 3,7	1	1,0	manual reset
3,7 - 5,7	6,4 - 9,9	UAT21 5,7	1	1,0	
5,3 - 8,2	9,2 - 14,2	UAT21 8,2	1	1,0	
8 - 12	13,9 - 20,1	UAT21 12	1	1,0	
12 - 18	20,1 - 31,2	UAT21 18	1	1,0	
16 - 24	27,7 - 41,6	UAT22 24	1	1,1	
24 - 37	41,6 - 64	UAT23 37	1	1,3	
32 - 49	55,4 - 85	UAT23 49	1	1,3	
48 - 72	83 - 125	UAT23 72	1	1,3	

Accessories

for overload relays for contactors

Type

Pack set Weight kg/set



Busbar Sets

U800	K3-450.., K3-550..	SU840/550	1	1,7
U800	K3-700.., K3-860..	SU840/860		2,1

Cable Cross-section (mm²) **Type**

for overload relay

solid or
stranded flexible

Pack pcs. Weight kg/pc.



Set for Single Mounting on DIN-rail with terminals

U12/16..K3	0,75 - 6	0,75 - 4	U12SM K3	1	0,035
------------	----------	----------	-----------------	---	-------



Additional Terminals with fingertouch protection

U3/32	0,75 - 6	0,75 - 4	U3/32SM	1	0,035
-------	----------	----------	----------------	---	-------



Set for Single Mounting on DIN-rail

U3/42, U3/74	-	-	U3/42G	1	0,030
--------------	---	---	---------------	---	-------

Connecting Wire Set for U3/42, U3/74 with Single Mounting



U3/42, U3/74	150mm lang	10mm ²	LG5830-4	1	0,060
U3/42, U3/74	250mm lang	10mm ²	LG5830-2	1	0,100

Additional Terminals with fingertouch protection



1-pole f. U12/16, U3/32	0,75 - 10	0,75 - 6	LG9339	1	0,009
-------------------------	-----------	----------	---------------	---	-------

3-pole for U3/42	4 - 35	6 - 25	LG7559	1	0,052
------------------	--------	--------	---------------	---	-------

Thermal Overload Relays, tripping times for selection to motors of protection degree EEx e

Relays With Standard Tripping Characteristic

Setting Range		Tripping time depending on the multiple of the current setting from cold condition (tolerance $\pm 20\%$ of the tripping time)					
A	A	I_A/I_N 3	I_A/I_N 4	I_A/I_N 5	I_A/I_N 6	I_A/I_N 7,2	I_A/I_N 8
U3/32 ..		s	s	s	s	s	s
0,12 -	0,18	16,1	9,6	6,8	5,3	4,2	3,7
0,18 -	0,27	16,6	9,7	6,7	5,2	4,1	3,6
0,27 -	0,4	19,4	11,4	7,9	6,1	4,7	4,2
0,4 -	0,6	18,7	10,9	7,6	5,9	4,6	4,0
0,6 -	0,9	19,2	11,2	7,7	5,9	4,6	4,1
0,8 -	1,2	20,8	12,3	8,5	6,6	5,2	4,6
1,2 -	1,8	25,5	14,1	9,8	7,6	5,9	5,2
1,8 -	2,7	26,6	15,6	10,9	8,3	6,5	5,7
2,7 -	4	22,7	13,6	9,5	7,4	5,8	5,1
4 -	6	22,2	13,3	9,3	7,1	5,6	4,9
6 -	9	20,4	11,9	8,2	6,1	4,7	4,0
8 -	11	20,9	11,8	7,9	5,7	4,3	3,5
10 -	14	21,3	11,7	7,4	5,1	3,7	3,0
13 -	18	21,2	12,1	8,0	6,2	4,6	4,1
17 -	24	20,4	12,0	8,6	6,3	4,5	3,7
23 -	32	20,2	10,2	6,7	4,7	3,4	2,8
U3/42		s	s	s	s	s	s
10 -	14	21,8	11,4	7,0	5,0	3,7	2,8
14 -	20	22,4	11,2	6,7	4,5	3,2	2,4
20 -	28	21,8	10,8	6,5	4,5	3,3	2,5
28 -	42	25,2	13,3	8,0	5,5	4,0	3,1
U3/74		s	s	s	s	s	s
20 -	28	21,8	10,8	6,5	4,5	3,3	2,5
28 -	42	25,2	13,3	8,0	5,5	4,0	3,1
40 -	52	18,3	9,2	5,6	3,9	2,8	2,2
52 -	65	17,8	8,7	5,2	3,4	2,5	1,9
U85 ..		s	s	s	s	s	s
60 -	90	19,5	13,5	11,0	10,0	9,5	8,5
80 -	120	18,0	11,0	10,0	9,0	8,5	8,0
U840 ..		s	s	s	s	s	s
260 -	360	23,3	14,1	10,0	7,6	6,1	5,4
340 -	480	23,0	13,8	9,6	7,6	6,1	5,4
440 -	620	20,5	12,4	9,0	7,0	5,5	5,0
560 -	800	21,0	12,5	9,0	7,0	5,6	5,2
U12/16E(A) ..		s	s	s	s	s	s
0,12 -	0,18	18,5	10,4	7,2	5,5	4,3	3,6
0,18 -	0,27	16,7	9,8	6,5	5,0	4,1	3,5
0,27 -	0,4	19,4	12,1	8,2	5,9	4,9	4,2
0,4 -	0,6	18,7	11,2	8,0	6,0	4,9	4,1
0,6 -	0,9	19,7	11,6	8,1	6,1	4,9	4,2
0,8 -	1,2	22,9	13,6	10,0	7,3	6,0	5,2
1,2 -	1,8	22,2	13,2	9,2	7,6	5,8	5,3
1,8 -	2,7	23,0	13,7	9,3	7,6	5,7	5,1
2,7 -	4	24,0	14,4	9,9	7,8	5,9	5,1
4 -	6	24,7	13,8	9,9	7,3	5,6	4,8
6 -	9	22,0	13,4	8	5,7	4,1	3,5
8 -	11	17,4	9,2	5,9	4,1	2,9	2,3
10 -	14	26,4	12,9	7,6	5,2	3,5	2,8
13 -	18	14,7	7,7	4,8	3,2	2,3	1,7
17 -	23	16,2	8,4	5,0	3,6	2,4	1,8
22 -	30	16,8	8,5	5,0	3,6	2,3	1,9

Relays With Quick Tripping Characteristic

preferably for motors with short t_E time and for submersible pumps

Setting Range		Tripping time depending on the multiple of the current setting from cold condition (tolerance $\pm 20\%$ of the tripping time)					
A	A	I_A/I_N 3	I_A/I_N 4	I_A/I_N 5	I_A/I_N 6	I_A/I_N 7,2	I_A/I_N 8
U12/16EQ ..		s	s	s	s	s	s
0,4 -	0,6	13,6	8,4	5,9	4,2	3,3	3,0
0,6 -	0,9	13,8	7,8	5,2	4,1	3,2	2,7
0,8 -	1,2	13,1	7,5	5,2	3,9	3,1	2,7
1,2 -	1,8	14,6	8,7	6,0	4,6	3,6	3,2
1,8 -	2,7	13,5	7,6	5,3	3,9	3,1	2,7
2,7 -	4	11,0	6,0	4,1	2,6	1,7	1,4
4 -	6	9,6	5,3	3,3	2,3	1,6	1,3
6 -	9	10,2	5,4	3,4	2,3	1,6	1,3
8 -	11	12,0	6,2	3,9	2,5	1,8	1,3
10 -	14	12,8	6,6	4,0	2,6	1,8	1,4

All tripping times of overload relays U12/16EQ are shorter than the minimum values of the t_E time for motors of protection degree EEx e acc. to EN 50019 and therefore are suitable for all motors of protection degree EEx e. For these overload relays the selection on basis of tripping curves is thereby not necessary.

When selecting a standard overload, refer to the tripping curve. Determine the values of the starting current ratio I_A/I_N and the time t_E which is marked on the label of the motor. The overload must trip within the t_E time, which means that the tripping curve from cold condition must be (20% due to tolerance) below the co-ordination point I_A/I_N and the time t_E .

I_A = Starting current of motor I_N = Rated current of motor
 t_E = t_E -time of motor

Time t_E /Tripping time

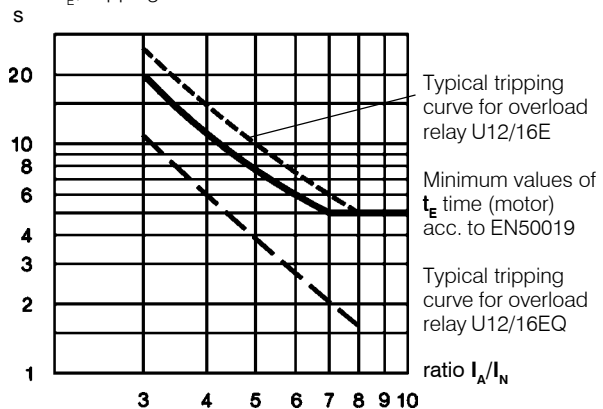

Labels of tripping curves for each setting range, sized 148x105mm (self-adhesive) are available on request.

Order No. D588, specify type and setting range.

Example of selection for thermal overload relay:

Technical data of a motor protection EEx e
 $P_N = 1,5\text{kW}$ $I_N = 3,6\text{A}$ $I_A/I_N = 5$ $t_E \text{ time} = 8\text{s}$

1) U12/16E 4 (2,7 - 4A)

Tripping time at $5 \times I_N = 9,9\text{s}$

$9,9\text{s} + 20\% \text{ tolerance} = 11,9\text{s} > t_{E \text{ Motor}} = 8\text{s}$

The device U12/16E 4 is **not suitable**.

2) U12/16EQ 4 (2,7 - 4A)

Tripping time at $5 \times I_N = 4,1\text{s}$

$4,1\text{s} + 20\% \text{ tolerance} = 4,9\text{s} < t_{E \text{ Motor}} = 8\text{s}$

The device U12/16EQ 4 is therefore suitable for motor protection

Thermal Overload Relays

Fuses for U3/32, U3/42, U3/74, U12/16E, U85, U180, U320 and U800

Type	Setting Range				Max. Fuse Size According to Coordination-type				Fuse UL	SCCR
	DOL	A		A	"2" ¹⁾		"1" ¹⁾			
		A	Δ		quick	slow, gL(gG)	slow, gL(gG)	aM	A	kA
U3/32 (U12/16E)	0,12 -	0,18	-	0,5 ²⁾	0,5 ²⁾	25	-	15	5	
	0,18 -	0,27	-	1,0 ²⁾	1,0 ²⁾	25	-	15	5	
	0,27 -	0,4	-	2	2	25	-	15	5	
	0,4 -	0,6	-	2	2	25	-	15	5	
	0,6 -	0,9	-	4	4	25	-	15	5	
	0,8 -	1,2	-	4	4	25	2	15	5	
	1,2 -	1,8	-	6	6	25	2	15	5	
	1,8 -	2,7	-	10	10	25	4	15	5	
	2,7 -	4	-	16	10	25	4	15	5	
	4 -	6	7 - 10,5	20	16	25	6	15	5	
	6 -	9	10,5 - 15,5	35	25	35	10	25	5	
	8 -	11	14 - 19	35	25	35	16	30	5	
	10 -	14	18 - 24	50	35	63	16	40	5	
13 -	18	23 - 31	50	35	63	20	50	5		
17 -	(23)24	30 - (40)41	63	50	63	25	60	5		
(22)23 -	(30)32	(38)40 - (52)55	80	63	80	35	70	5		
U3/42	10 -	14	18 - 24	50	35	80	16	40	5	
	14 -	20	24 - 35	63	50	80	25	60	5	
	20 -	28	35 - 48	80	63	80	35	80	5	
	28 -	42	48 - 73	100	80	150	50	110	5	
U3/74	20 -	28	35 - 48	100	80	150	35	80	5	
	28 -	42	48 - 73	125	100	150	50	110	5	
	40 -	52	70 - 90	160	100	150	63	200	5	
	52 -	65	90 - 112	160	125	150	80	250	10	
	60 -	74	104 - 128	160	125	150	80	250	10	
U85	60 -	90	104 - 156					300	10	
	80 -	120	140 - 207					-	10	
U180, U320 U800	all ranges all ranges			For short circuit protecting overload relays with current transformer use fuse according to the contactor of the combination.				-	-	

Tripping Characteristics for U3/32, U3/42, U3/74 and U12/16E

Detailed tripping times for each range see table page 106

with three-phase load

Tripping time (Average value of typical tolerance curves from cold condition)

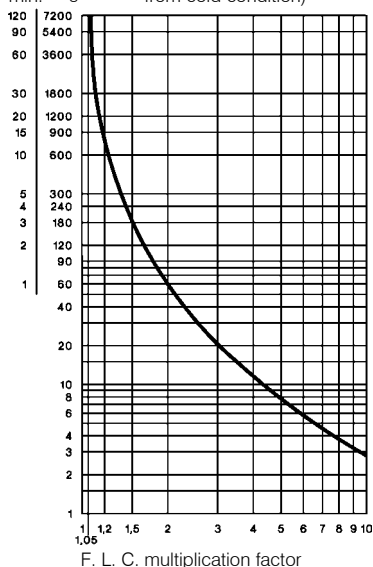

with two-pole load

Tripping time (Typical tolerance curve from cold condition)

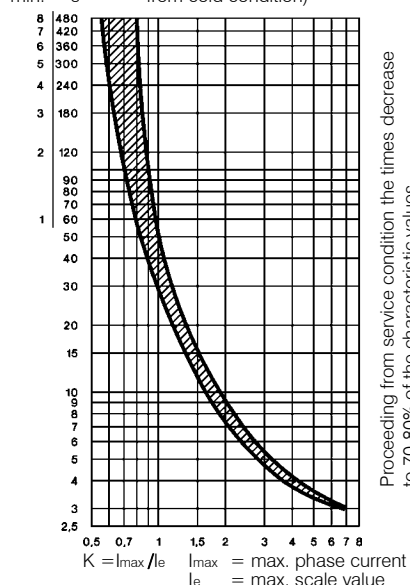

1) Coordination-type according to IEC 947-4-1:
"2": Light contact welding accepted. Thermal overload relay must not be damaged.
"1": Welding of contactor and damage of the thermal overload relay allowed.

2) Miniature fuse

3) Suitable for use on a capability of delivering not more than

Thermal Overload Relays

Tripping Characteristics for U85, U180, U320, and U800

Detailed tripping times for each range of U85 see table page 106

U85 with three-phase load

Tripping time (Average value of typical tolerance curves from cold condition)

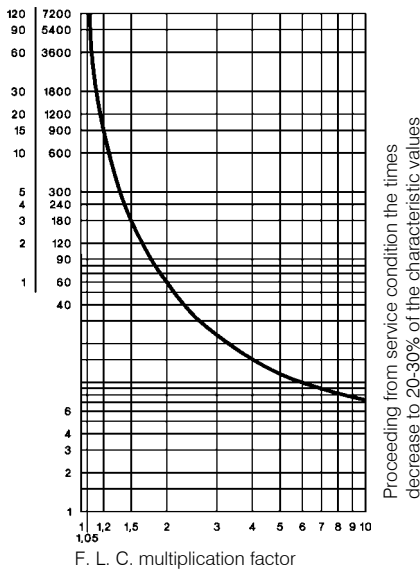

U180, U320 with three-phase load

Tripping time (Average value of typical tolerance curves from cold condition)

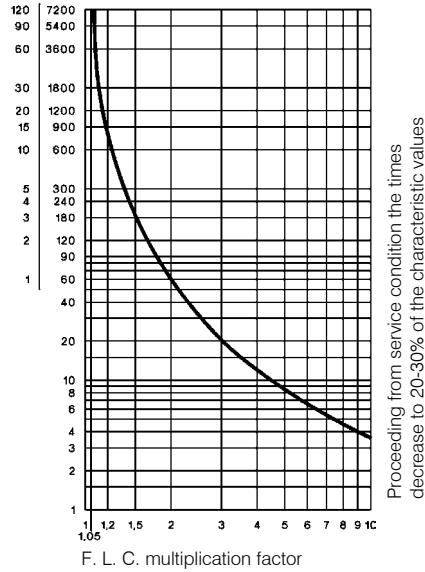

U800 with three-phase load

Tripping time (Average value of typical tolerance curves from cold condition)

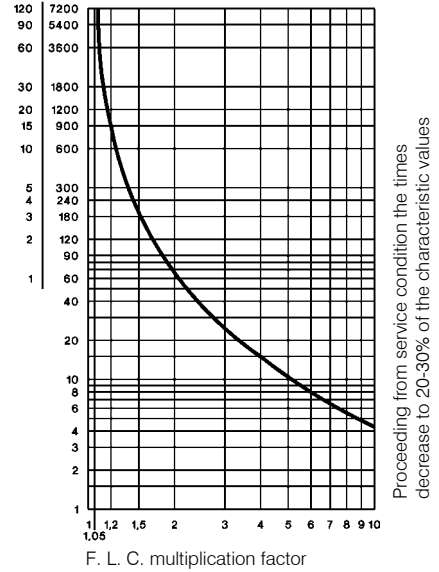

U85 with two-pole load

Tripping time (Typical tolerance curve from cold condition)

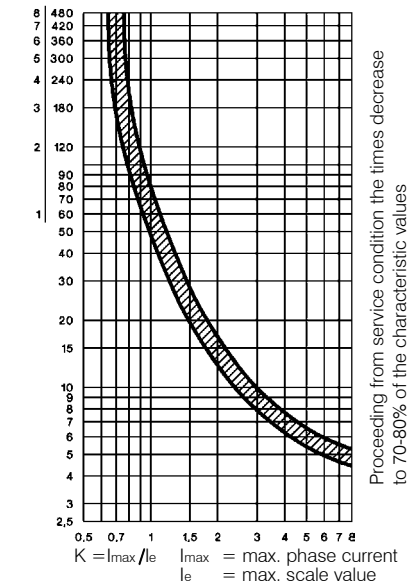

Position of Terminals

U3/32

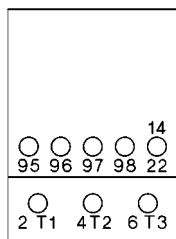

U12/16E, U12/16EM, U12/16EQ

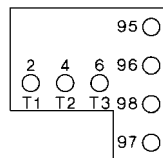

U12/16A

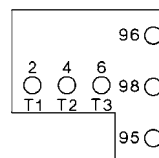

U3/42, U3/74

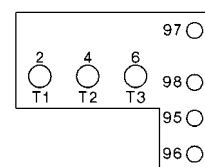

Thermal Overload Relays in Special Version

Fuse for U12/16EQ

Setting Range	Maximum Fuse Acc. to Coordination-type "2" ¹⁾		
	quick A	slow, gL(gG) A	slow, gL(gG) "1" ¹⁾ A
0,4 - 0,6	2	2	25
0,6 - 0,9	4	4	25
0,8 - 1,2	4	4	25
1,2 - 1,8	6	6	25
1,8 - 2,7	10	10	25
2,7 - 4	16	10	25
4 - 6	20	16	25
6 - 9	35	25	35
8 - 11	35	25	35
10 - 14	50	35	63

Fuse for U12/16EM

Setting Range	Maximum Fuse Acc. to Coordination-type "2" ¹⁾		
	380-400V slow, gL(gG) A	500V slow, gL(gG) A	660-690V slow, gL(gG) A
0,12 - 0,18	none	none	on request
0,18 - 0,27	none	none	on request
0,27 - 0,4	none	none	on request
0,4 - 0,6	none	none	on request
0,6 - 0,9	none	none	on request
0,8 - 1,2	none	10	on request
1,2 - 1,8	none	16	on request
1,8 - 2,7	20	20	on request
2,7 - 4	35	35	on request

Tripping Characteristic for U12/16EQ

Detailed tripping times for each range see table page 106

with three-phase load

range 0,4-0,6 to 1,8-2,7A

Tripping time (Typical tolerance curve from cold condition)

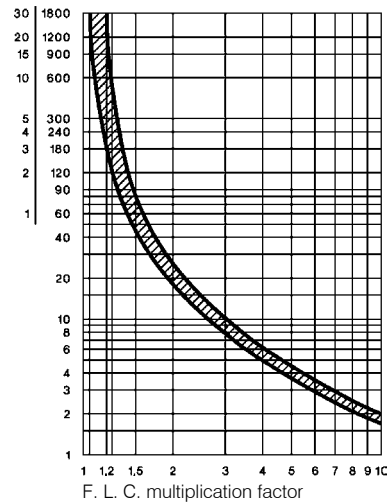

range 2,7-4 to 10-14A

Tripping time (Typical tolerance curve from cold condition)

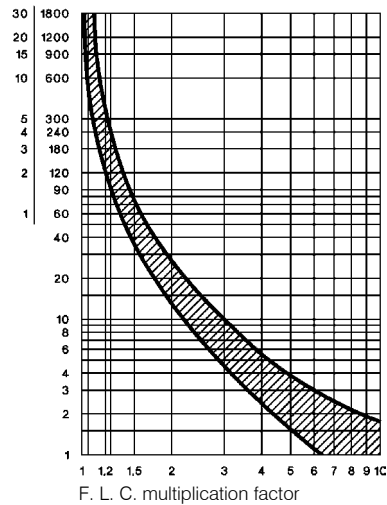

Tripping Characteristic for U12/16EM

with three-phase load

Tripping time (Average value of typical tolerance curves from cold condition)

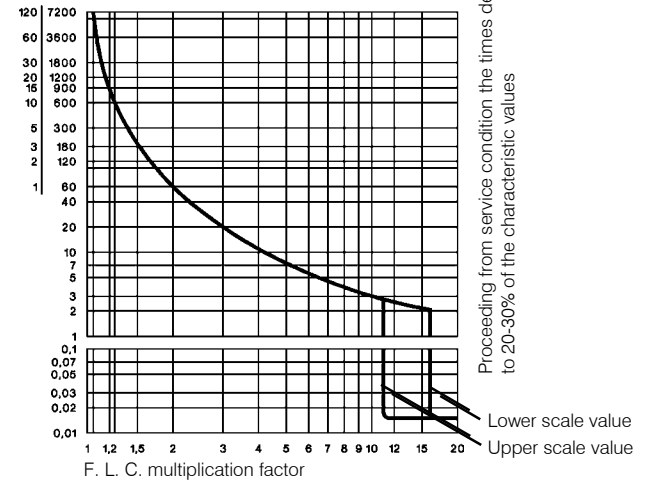

Fuse for UAT21, UAT22, UAT23

For short circuit protecting thermal overload relays with current transformer use fuse according to the contactor of the combination.

Tripping characteristic for UAT21, UAT22, UAT23

with three-phase load

Tripping time in s (Typical tolerance curve from cold condition)

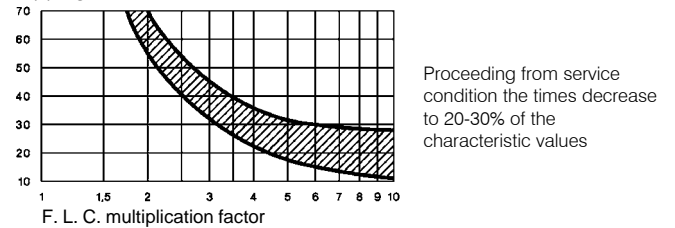

1) Coordination-type according to IEC 947-4-1:
 "2": Light contact welding accepted. Thermal overload relay must not be damaged.
 "1": Welding of contactor and damage of the thermal overload relay allowed.

Thermal Overload Relays

Data according to IEC 947-4-1, IEC 947-5-1, VDE 0660, EN 60947-4-1, EN 60947-5-1

Type		U3/32	U12/16 ⁶⁾	U3/42	U3/74	U85	U180	U320	U800	UAT21	UAT22	UAT23
Rated insulation voltage $U_i^{1)}$	V~	690	690	690	690	750	690	1000	1000	690	690	690
Permissible ambient temperature												
operation	open °C			-25 to +60					-25 to +55	-25 to +60		
storage	°C			-50 to +70					-40 to +70	-50 to +70		
Trip class according to IEC 947-4-110A		10A	10A	10A	10A	20	10A	10A	10	30	30	30
Cable cross-section												
main connector	solid or stranded mm ²	0,75-6	0,75-6+0,75-2,5 ²⁾	0,75-10	4-35 ²⁾	3)	7)	-	7)	0,5-10	0,5-16	0,5-25
	flexible mm ²	1-4	0,75-4+0,5-2,5 ²⁾	0,75-6	6-25 ²⁾					0,5-6	0,5-10	0,5-16
	flexible with multicore cable end mm ²	0,75-4	0,5-2,5+0,5-1,5	0,75-6	4-25					0,5-6	0,5-10	0,5-16
Cables per clamp	number	2	1+1	2	1					1	1	1
auxiliary connector	solid mm ²			0,75-2,5 ²⁾					1-2,5 ²⁾	0,75-2,5 ²⁾		
	flexible mm ²			0,5-2,5 ²⁾					1-2,5 ²⁾	0,5-2,5 ²⁾		
	flexible with multicore cable end mm ²			0,5-1,5					1-2,5 ²⁾	0,5-1,5		
Cables per clamp	number			2					2	2		
Type		U3/32	U12/16A	U12/16E	U12/16EQ	U3/42	U85	U180	U800	UAT21	UAT22	UAT23
Auxiliary contacts												
Rated insulation voltage $U_i^{1)}$												
same potential	V~	690	690	690	690	690	690	690	500	690		
different potential	V~	440	-	440	440	250	440	440	500	440		
Utilization category AC15												
Rated operational current I_e	24V A	3	4	5	5	4	5	3	4 ⁵⁾	5		
	230V A	2	2,5	3	3	2,5	3	2	2,5	3		
	400V A	1	1,5	2	2	1,5	2	1	1,5	2		
	690V A	0,5	0,6	0,6	0,6	0,6	0,6	0,5	0,6	0,6		
Utilization category DC13												
Rated operational current I_e	24V A	1	1,2	1,2	1,2	1,2	1,2	1,2	1,2	1,2		
	110V A	0,15	0,15	0,15	0,15	0,15	0,15	0,15	0,15	0,15		
	220V A	0,1	0,1	0,1	0,1	0,1	0,1	0,1	0,1	0,1		
Short circuit prot. (without welding 1kA)												
highest fuse rating	gL (gG) A	4	4	6	6	6	6	4	6	6		
Type		U3/32	U12/16	U12/16E	U3/42	U3/42	U3/74	U3/74	U3/74	U85		
Setting range		all	to 23A	22 - 30A	to 28A	28 - 42A	to 52A	52 - 65A	52 - 65A	all		
Power loss per current path (max.)												
minimum setting value	W	1,1	1,1	1,7	1,3	1,3	2,0	2,9	1,1			
maximum setting value	W	2,3	2,3	3,7	2,6	3,3	3,7	4,5	2,5			

Data according to cULus

Type		U3/32	U12/16A	U12/16E	U12/16EQ	U3/42	U3/74	U85
Rated insulation voltage	V~	600	600	600	600	600	600	600
Rated current	A	32	23	23	23	42	74	85
Auxiliary contacts								
Rated voltage								
same potential	V AC	600	600	600	600	600	600	600
different potential	V~	150	-	150	150	150	150	150
Switching capacity AC	VA	500	500	500	500	600	600	600
of aux. contacts	A	2	3	4	4	4	4	4

Temperature Compensation

In case of higher ambient temperature use the following formula:
 (Ambient temperature - 20) x 0,125 = correction factor in % of the full load motor current

Example: Ambient temperature 70°C, full load motor current 7A
 (70 - 20) x 0,125 = 6,25%
 Setting value: 7A + 6,25% = 7,44A

1) Suitable for: earthed-neutral systems, overvoltage category I to III, pollution degree 3 (standard-industry): $U_{imp} = 4kV$ (at 440V), 6kV (at 690V).
 Data for other conditions on request.

2) Maximum cable cross-section with prepared conductor

3) Without terminals, suitable for bushing one connector 70mm² (stranded) per phase

4) Switching capacity of the start contact: AC15 300VA, max. 1,5A, DC13 (max. 220V) 30W, max. 1,5A

5) Switching capacity of the make contact: AC15 400VA, max. 1,7A, DC13 (max. 220V) 10W, max. 1A

6) U12/16E 30: Cable cross-section for main connector like type U3/42, one connector only

7) Busbar sets see accessories page 103

Thermal Overload Relays

Dimensions

K3-10N + U3/32

K3-14N

K3-18N

K3-22N

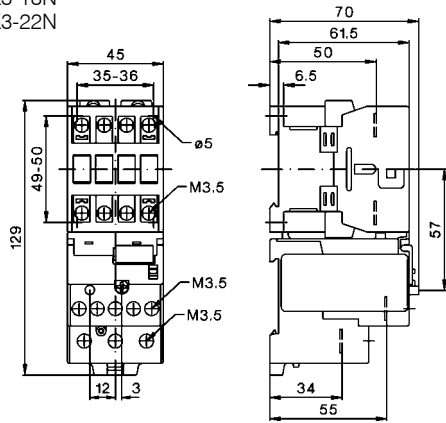

KG3-10 + U3/32

KG3-14

KG3-18

KG3-22

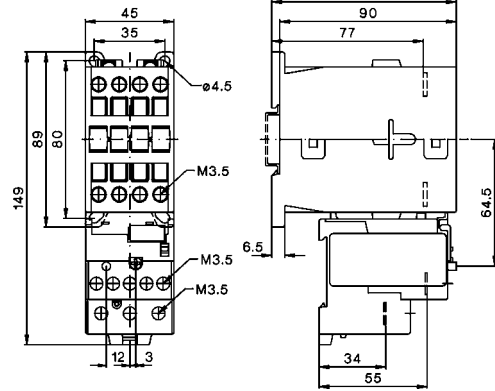

K3-24 + U3/32

K3-32

K3-40

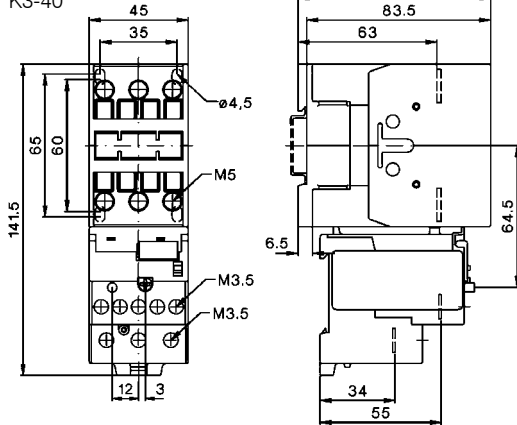

KG3-24 + U3/32

KG3-32

KG3-40

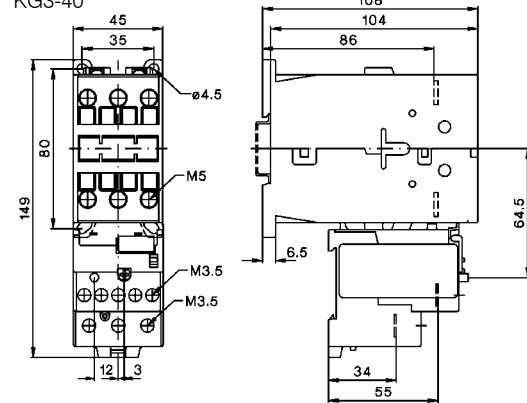

K3-24 + U3/42

K3-32

K3-40

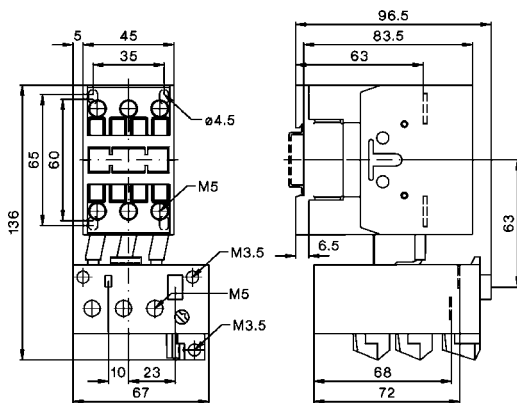

KG3-24 + U3/42

KG3-32

KG3-40

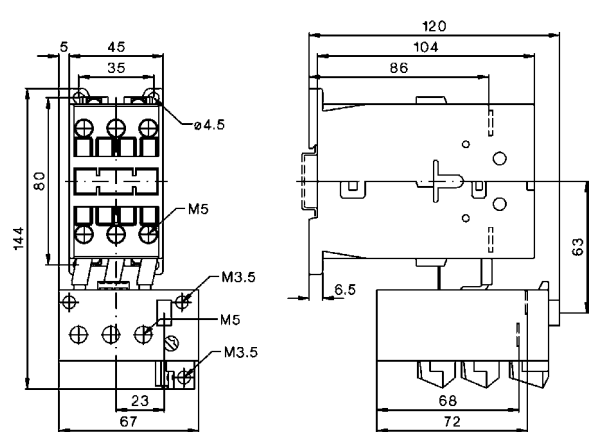

U3/32SM

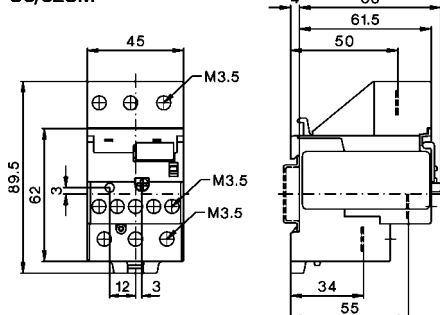

U3/42G + LG5830-

Changing of connecting wire with 1,8Nm

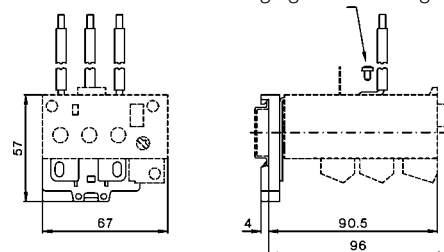

Thermal Overload Relays

Dimensions

K1-09 + U12/16.. K1
K1-12

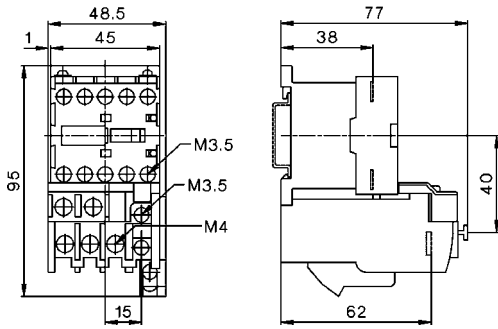

K3-10 + U12/16..K3
K3-14
K3-18
K3-22

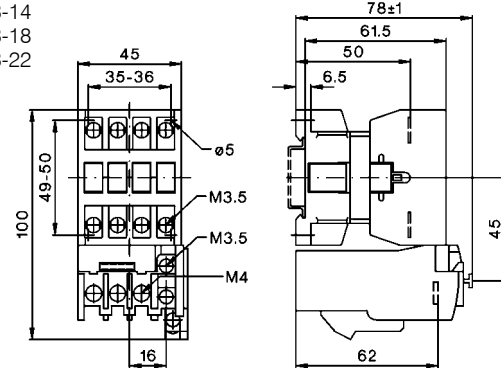

K3-10N + U12/16..K3
K3-14N
K3-18N
K3-22N

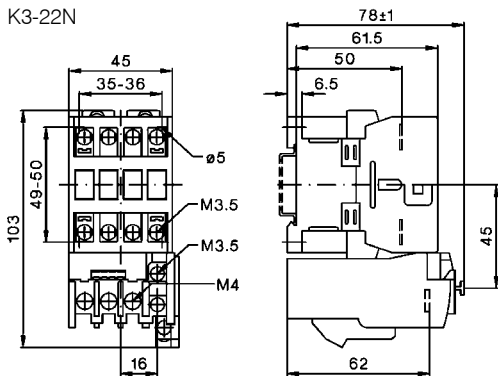

KG3-10 + U12/16..K3
KG3-14
KG3-18
KG3-22

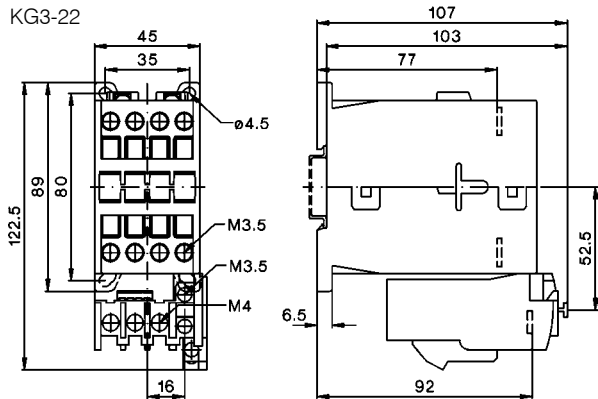

U12SM K3

U12/16..K3 + U12SM K3 for snap-on 35mm DIN-rail according to DIN EN50022 and screw mounting (single mounting)

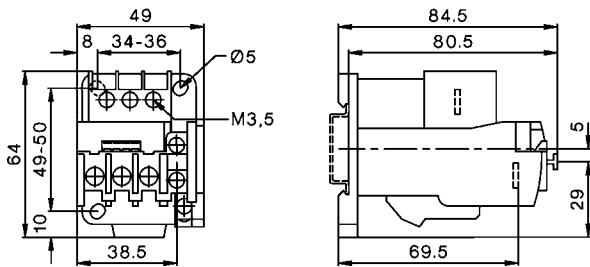

K3-50 + U3/74
K3-62
K3-74

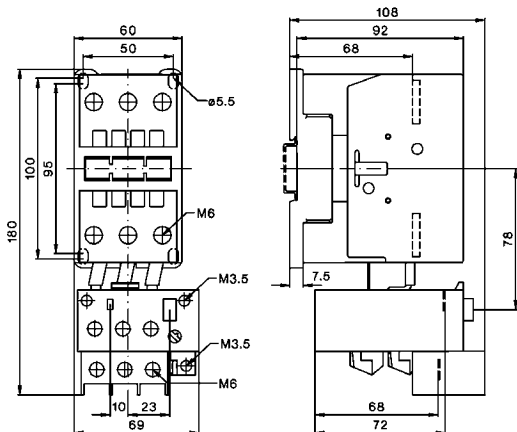

Thermal Overload Relays

Dimensions

K3-90A + U85
K3-115A

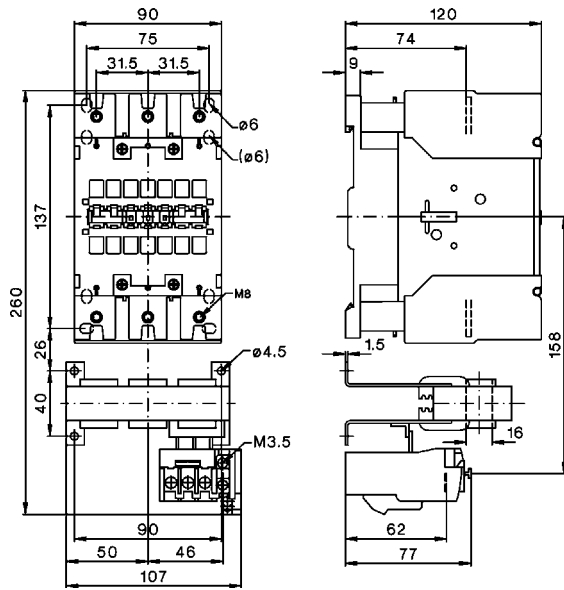

K3-151A00 + U180
K3-176A00

Bohrplan

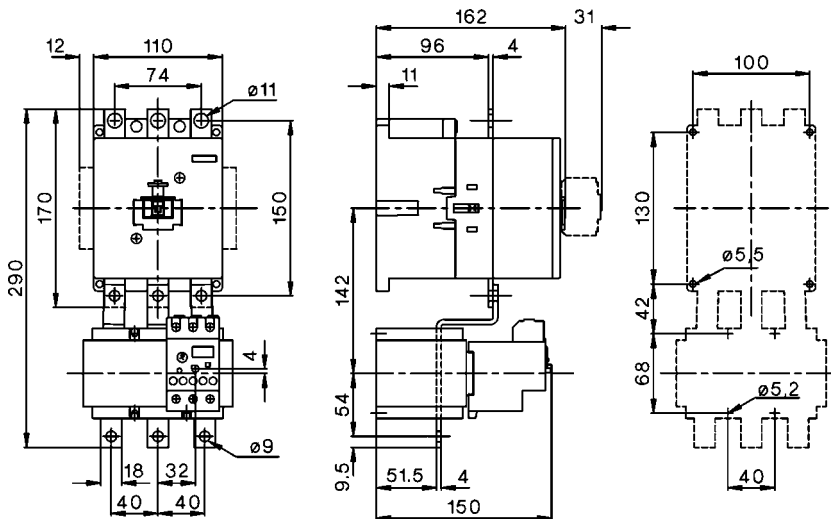

K3-210A00 + U320
K3-260A00
K3-316A00

Bohrplan

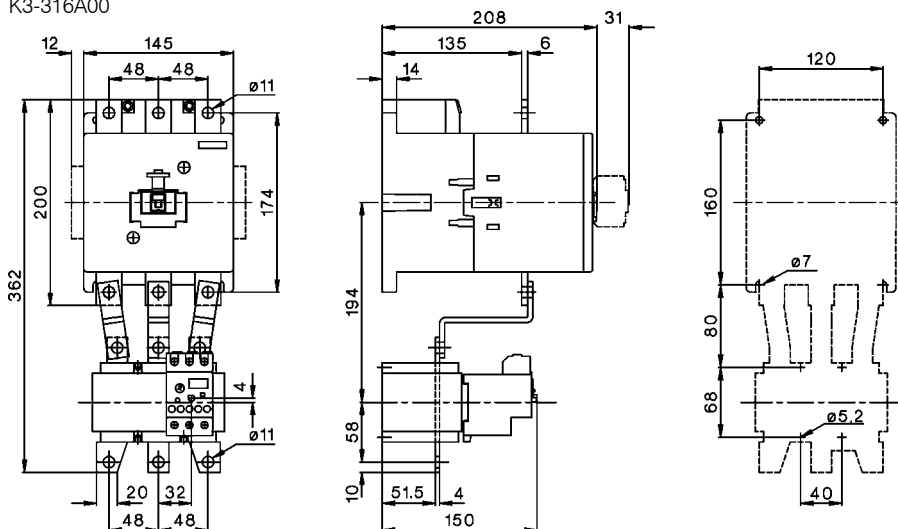

Thermal Overload Relays

Dimensions

U800

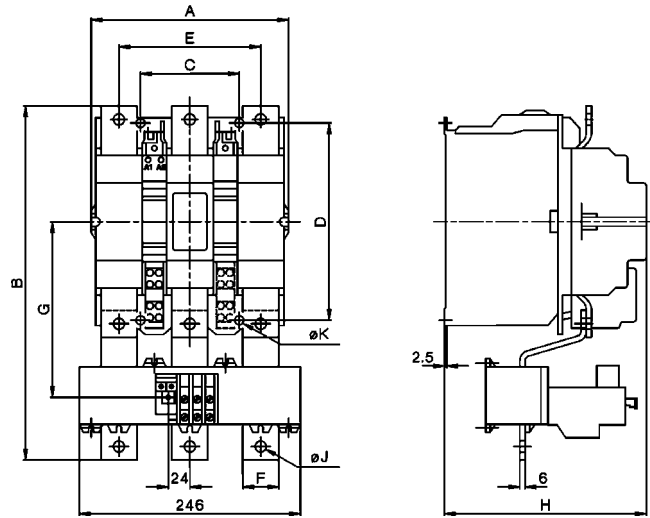
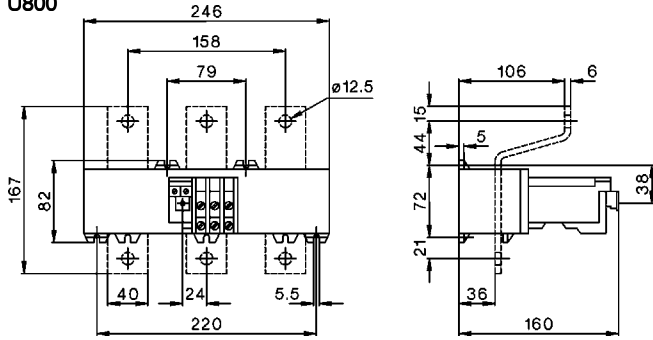

U800 with	A	B	C	D	E	F	G	H	J	K
K3-450	220	372	110	220	158	40	185	225	12,5	9
K3-550	220	395	110	220	158	40	196	225	12,5	9
K3-700	280	487	175	280	202	50	257	291	14,5	11
K3-860	280	540	175	280	202	50	280	291	14,5	11

UAT21

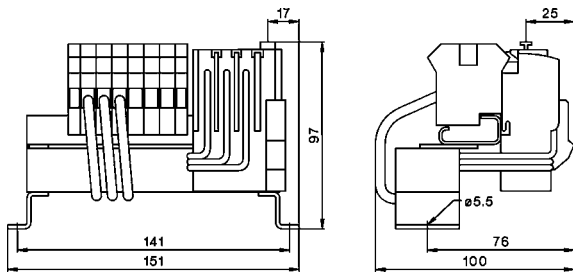

UAT22

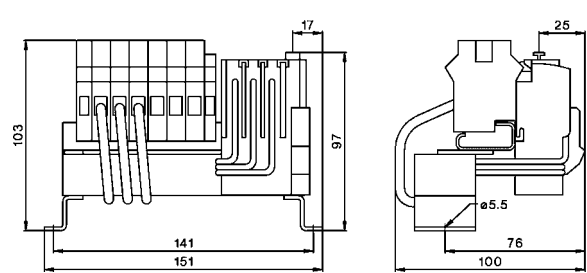

UAT23

Type	Setting Range	A	B
UAT23 37	23-37A	105,5	97,5
UAT23 49	32-49A	94	86
UAT23 72	48-72A	94	86

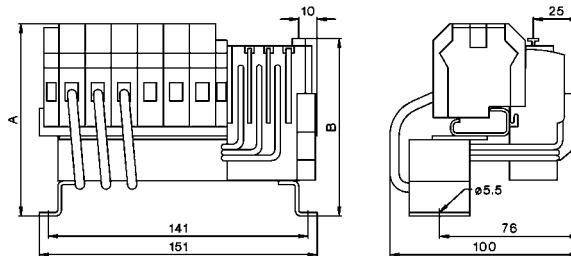



Modular Contactors

116



Auxiliary Contact Block
Accessories

117
117



Day-Night Reloading Contactors

118



Switching Of Lamps

118



Technical Data

120

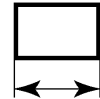

Dimensions

122

Modular Contactors

Rated Current	Heating Power AC1 at		Type	coil voltage	Pack pcs.	Weight kg/pc.	Wiring Diagram
	1-phase	3-phase					
400V	230V	400V	24 230 24VM 230VM ↓	24V 50/60Hz	12	0,12	
	A	kW		kW			

One-pole 1 module (17,5mm)



20	4,6	-	R20-10 24	12	0,12	
20	4,6	-	R20-10 230	12	0,12	

Two-pole 1 module (17,5mm)



20	4,6	-	R20-20 24	12	0,12	
20	4,6	-	R20-20 230	12	0,12	

20	4,6	-	R20-11 24	12	0,12	
20	4,6	-	R20-11 230	12	0,12	

20	4,6	-	R20-02 24	12	0,12	
20	4,6	-	R20-02 230	12	0,12	

25	5,5	-	R25-20 24	12	0,14	
25	5,5	-	R25-20 230	12	0,14	

25	5,5	-	R25-11 24	12	0,14	
25	5,5	-	R25-11 230	12	0,14	

25	5,5	-	R25-02 24	12	0,14	
25	5,5	-	R25-02 230	12	0,14	

Four-pole 2 modules (35mm) ¹



25	5,7	17	R25-40 24	6	0,21	
25	5,7	17	R25-40 230	6	0,21	

25	5,7	17	R25-31 24	6	0,21	
25	5,7	17	R25-31 230	6	0,21	

25	5,7	17	R25-13 24	6	0,21	
25	5,7	17	R25-13 230	6	0,21	

25	5,7	-	R25-22 24	6	0,21	
25	5,7	-	R25-22 230	6	0,21	

25	5,7	17	R25-04 24	6	0,21	
25	5,7	17	R25-04 230	6	0,21	

Four-pole 2 modules(35mm), AC/DC-operated ¹⁾



25	5,7	17	R25-40 24VM	6	0,22	
25	5,7	17	R25-40 230VM	6	0,22	

25	5,7	17	R25-31 24VM	6	0,22	
25	5,7	17	R25-31 230VM	6	0,22	

25	5,7	17	R25-13 24VM	6	0,22	
25	5,7	17	R25-13 230VM	6	0,22	

25	5,7	-	R25-22 24VM	6	0,22	
25	5,7	-	R25-22 230VM	6	0,22	

25	5,7	17	R25-04 24VM	6	0,22	
25	5,7	17	R25-04 230VM	6	0,22	

1) Sealable with Sealing Cover P721, available aux. contact block RH11(see page 117)

2) Sealable with Sealing Cover P721, available aux. contact block RH11-1(see page 117)

Modular Contactors

Rated Current	Heating Power AC1 at	Type	coil voltage	Pack pcs.	Weight kg/pc.	Wiring Diagram
AC1	1-phase 3-phase	24 230	24V 50/60Hz			
400V	230V 400V	↓	220-240V 50Hz, 230-264V 60Hz			
A	kW kW					



Two-pole 2 modules (35mm)

40	9	-	R40-20	24	6	0,23
40	9	-	R40-20	230	6	0,23
63	14,3	-	R63-20	24	6	0,23
63	14,3	-	R63-20	230	6	0,23

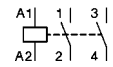

Four-pole 3 modules (52,5mm) ¹⁾



40	9	27,5	R40-40	24	4	0,35
40	9	27,5	R40-40	230	4	0,35
40	9	27,5	R40-31	24	4	0,35
40	9	27,5	R40-31	230	4	0,35
40	9	-	R40-22	24	4	0,35
40	9	-	R40-22	230	4	0,35
40	9	27,5	R40-04	24	4	0,35
40	9	27,5	R40-04	230	4	0,35

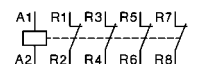
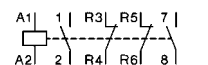
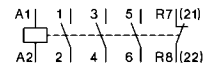
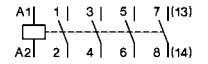

63	14,3	43	R63-40	24	4	0,36
63	14,3	43	R63-40	230	4	0,36
63	14,3	43	R63-31	24	4	0,36
63	14,3	43	R63-31	230	4	0,36
63	14,3	-	R63-22	24	4	0,36
63	14,3	-	R63-22	230	4	0,36
63	14,3	43	R63-04	24	4	0,36
63	14,3	43	R63-04	230	4	0,36

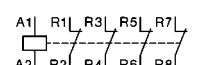
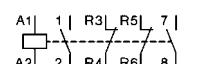
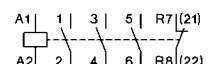
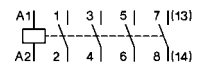

Auxiliary Contact Block ^{1/2} module (8,8mm) for contactor R25 (4p.), R40, R63 (max. 1pc.)



Rated current	Type	Pack pcs.	Weight kg/pc.	Wiring Diagram
AC15 AC15 AC1				
230V 400V 690V				
A A A	for contactor			
3 2 10 R25 ²⁾ , R40, R63	RH11	3	0,026	31 43
3 2 10 R25-...VM	RH11-1	3	0,026	32 44

Accessories



Type	Pack pcs.	Weight kg/pc.
RC-unit 2x for R20.. to R63.. for 12V to 250V AC 220nF / 100 Ohm not for R25-...VM	RC-R 230	2 0,05



Spacing piece ^{1/2} module (8,8mm) for R20.. to R63.. for ambient temperature >40°C	P730	10	0,012
--	------	----	-------

Sealing cover for R25.. (4p.)	P721	10	0,002
Sealing cover for R40..., R63..	P690	10	0,003



1) Sealable with Sealing Cover P690, available aux. contact block RH11
 2) AC-operated R25-..., 4-pole

Day-Night Reloading Contactors

Type Pack pcs. Weight kg/pc. Wiring Diagram

Compact Module, for separate tariff counters 2 modules (35mm)



3-pole 400V 25A **R25-TN 230** 1 0,22

2 Switch positions:
Day (Reloading, contact 11-14 ... closed, remains in position Night, until the next occurs)
Night (Basis operation) contact 11-12 ... closed

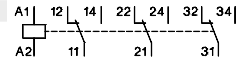

Contactor Module, for double tariff counters 1 module (17,5mm)



2-pole 400V 25A **R25-TN20 230** 1 0,13

4 Switch position:
Day (Reloading, contact 1-2 ... closed, remains in position Night, until the next occurs)
Night (automatic operation, contact 1-2 ... only at night closed)
On (Permanently On)
Off (permanently Off)



Switch Module 1 module (17,5mm)



2-pole 400V 25A **RH25-20** 1 0,13



Modular Contactors

Switching of lamps

Lamp Type	Power W	Current A	Capacitors μF	Max. lamps per pole at 230V 50Hz and max. 60°C			
				R20..	R25..	R40..	R63..
Incandescent lamps	60	0,27	-	22	50	92	129
	100	0,45	-	13	30	55	77
	200	0,91	-	10	15	27	38
	300	1,36	-	4	10	19	26
	500	2,27	-	3	6	11	16
	1000	4,5	-	1	3	6	8
Fluorescent lamps uncompensated or serial compensated	11	0,16	1,3	60	75	210	310
	18	0,37	2,7	25	30	90	140
	24	0,35	2,5	25	30	90	140
	36	0,43	3,4	20	25	70	140
	58	0,67	5,3	14	17	45	70
	65	0,67	5,3	13	16	40	65
Fluorescent lamps dual-connection	11	0,07	-	2 x 100	2 x 110	2 x 220	2 x 250
	18	0,11	-	2 x 50	2 x 55	2 x 130	2 x 200
	24	0,14	-	2 x 40	2 x 44	2 x 110	2 x 160
	36	0,22	-	2 x 30	2 x 33	2 x 70	2 x 100
	58	0,35	-	2 x 20	2 x 22	2 x 45	2 x 70
	65	0,35	-	2 x 15	2 x 16	2 x 40	2 x 60
Fluorescent lamps parallel compensated	11	0,09	2,0	30	43	67	107
	18	0,13	2	20	32	50	80
	24	0,16	3	15	32	50	80
	36	0,27	4	10	32	50	80
	58	0,45	7	6	18	36	46
	65	0,5	7	5	18	36	46
85	0,6	8	4	16	33	44	

Modular Contactors

Switching of lamps

Lamp Type	Power W	Current A	Capacitors µF	Max. lamps per pole at 230V 50Hz and max. 60°C				
				R20..	R25..	R40..	R63..	
Fluorescent lamps with electronic fluorescent lamp ballast	18	0,09	-	40	40	100	150	
	36	0,16	-	20	20	52	75	
	58	0,25	-	15	15	30	55	
	80	0,4	-	7	10	20	30	
	2 x 18	0,17	-	20	20	50	60	
	2 x 28	0,25	-	15	15	37	45	
	2 x 36	0,32	-	10	10	25	30	
	2 x 58	0,49	-	7	7	15	20	
2 x 80	0,7	-	4	4	8	10		
Transformers for metal halid low voltage lamps	20	0,09	-	40	52	110	174	
	50	0,22	-	20	24	50	80	
	75	0,33	-	13	16	35	54	
	100	0,43	-	10	12	27	43	
	150	0,65	-	7	9	19	29	
	200	0,87	-	5	5	14	23	
Mercury-vapour lamps (high-pressure lamps), uncompensated e. g. HQL, HPL	50	0,61	-	16	21	38	55	
	80	0,8	-	12	16	29	40	
	125	1,15	-	8	11	20	28	
	250	2,15	-	4	6	11	15	
	400	3,25	-	3	4	7	10	
	700	5,4	-	1	2	4	6	
	1000	7,5	-	1	1	3	4	
	Mercury-vapour lamps (high-pressure lamps), compensated e. g. HQL, HPL	50	0,28	7	7	18	36	50
80		0,41	8	5	16	31	44	
125		0,65	10	3	13	25	35	
250		1,22	18	2	7	14	19	
400		1,95	25	1	5	10	14	
700		3,45	45	1	3	6	8	
1000		4,8	60	-	2	4	6	
Metal halide lamps uncompensated e. g. HQI, HPI, CDM		35	0,53	-	22	24	57	65
	70	1	-	12	14	30	35	
	150	1,8	-	6	8	17	18	
	250	3	-	4	5	10	12	
	400	3,5	-	3	4	8	10	
	1000	9,5	-	1	1	3	4	
	2000	16,5	-	-	-	2	2	
	400V per pole	2000	10,5	-	-	2	2	
	3500	18	-	-	-	1	1	
	Metal halide lamps compensated e. g. HQI, HPI, CDM	35	0,25	6	8	21	42	58
		70	0,45	12	4	11	21	29
		150	0,75	20	2	7	13	18
250		1,5	33	1	4	9	11	
400		2,1	35	1	4	9	10	
1000		5,8	95	-	1	3	4	
2000		11,5	148	-	-	2	2	
400V per pole		2000	6,6	58	-	-	3	4
3500	11,6	100	-	-	2	3		
Metal halide lamps with electronic fluorescent with electronic fluorescent lamp ballast (e. g.: PCI) 50-125 x I _n lamp for 0,6ms	20	0,1	integrated	9	9	18	20	
	28	0,15	integriert	-	-	-	18	
	35	0,2	integrated	6	6	11	13	
	70	0,36	integrated	5	5	10	12	
	150	0,7	integrated	4	4	8	10	
Sodium-vapour lamps (low pressure lamps), uncompensated	35	1,5	-	7	9	22	30	
	55	1,5	-	7	9	22	30	
	90	2,4	-	4	6	13	19	
	135	3,3	-	3	4	10	14	
	150	3,3	-	3	4	10	14	
	180	3,3	-	3	4	10	14	
	200	3,3	-	3	4	10	14	

Modular Contactors

Switching of lamps

Lamp Type	Power W	Current A	Capacitors μF	Max. lamps per pole at 230V 50Hz and max. 60°C			
				R20..	R25..	R40..	R63..
Sodium-vapour lamps (low pressure lamps), compensated	35	0,31	20	3	6	15	18
	55	0,42	20	2	6	15	18
	90	0,63	30	1	4	10	12
	135	0,94	45	1	3	7	8
	150	1	40	1	3	8	9
	180	1,16	40	1	3	8	9
	200	1,32	25	-	-	10	12
Sodium-vapour lamps (high pressure lamps), uncompensated	150	1,8	-	5	8	17	22
	250	3	-	4	5	10	13
	330	3,7	-	3	4	8	10
	400	4,7	-	2	3	6	8
	1000	10,3	-	1	1	3	4
Sodium-vapour lamps (high pressure lamps), compensated	150	0,83	20	2	7	20	25
	250	1,5	33	1	4	12	15
	330	2	40	1	3	10	13
	400	2,4	48	1	2	8	12
	1000	6,3	106	-	1	4	6
Sodium-vapour lamps (high pressure lamps) with serial electronic (e. g.: PCI) 50-125 x $I_{n\text{lamp}}$ for 0,6ms	20	0,1	integrated	9	9	18	20
	35	0,2	integrated	6	6	11	13
	70	0,36	integrated	5	5	10	12
	150	0,7	integrated	4	4	8	10

Data according to IEC60 947-4-1, IEC 60947-5-1, VDE 0660-5-1

Type	2-pole				4-pole			RH 11
	R20	R25	R40	R63	R25	R40	R63	
Main Contacts ^{5) 6) 7)}								
Rated insulation voltage U_i	V~	440 ²⁾	440 ²⁾	440 ²⁾	440 ²⁾	440 ²⁾	440 ²⁾	440 ²⁾
Rated operation voltage U_e	V~	440	440	440	440	440	440	440
Frequency of operations zAC1, AC3 1/h		300	300	600	600	300	600	600
Mechanical life	S x 10 ⁶	1	1	1	1	1	1	1
Utilization category AC1								
Rated operational current I_e (= I_{th}) open at 60°C	A	20	25	40	63	25	40	63
Contact life	S x 10 ⁶	0,1	0,1	0,1	0,1	0,1	0,1	0,1
Minimum Switch Voltage	V/mA	24/100	24/100	24/100	24/100	24/100	24/100	24/100
Short time current 10s-current	A	72	72	216	240	72	216	240
Power loss per pole at $I_e/AC1$	W	3	3	7	2	3	7	0,5
Utilization category AC3 / AC7b								
Switching of three-phase motors								
Rated operational current I_e	A	-	-	-	-	9	27	30
Rated operational power of three-phase motors	220V kW	-	-	-	-	2,2	7,5	8
50-60Hz	230-240V kW	-	-	-	-	2,5	8	8,5
	380-415V kW	-	-	-	-	4	12,5	15
2-pole motors	230V kW	1,1	1,3	2,6	5	-	-	-
Contact life	S x 10 ⁶	0,15	0,15	0,15	0,15	0,15	0,15	0,15
Power consumption of coils								
AC operated	inrush VA	7 - 9	7 - 9			20 - 25	33 - 45	33 - 45
	sealed VA	2,2 - 4,2	2,2 - 4,2	5 - 7	5 - 7	4 - 6	6 - 8	6 - 8
	W	0,8 - 1,6	0,8 - 1,6			1,5 - 2,5	2,6	2,6
AC and DC-operated	W	-	-			3 - 4	-	-
Operation range of coils								
in multiples of control voltage U_s (-40°--+40°C)		0,85 - 1,1	0,85 - 1,1	0,85 - 1,1	0,85 - 1,1	0,85 - 1,1	0,85 - 1,1	0,85 - 1,1

1) Suitable for: earthed-neutral systems, overvoltage category I to IV, pollution degree 3 (standard-industry): $U_{imp} = 8\text{kV}$.

2) Suitable for: earthed-neutral systems, overvoltage category I to III, pollution degree 3 (standard-industry): $U_{imp} = 4\text{kV}$.

3) Maximum cable cross-section with prepared conductor

5) Rated frequency 50/60Hz

6) Max. occ. switching overvoltage <4kV

7) Duty cycle: 100%

Modular Contactors

Data according to IEC60 947-4-1, IEC 60947-5-1, VDE 0660-5-1

Type	R20	R25 (2p.)	R25 (4p.)	R25-..VM	R40	R63	RH11
Short circuit protection							
max. fuse Coordination-type "1" gL (gG) A	35	35	35	35	63	80	-
Rated short circuit current "I _{sc} " kA	3	3	3	3	3	3	-
"I _q " kA	3	3	10	10	10	10	-
Switching time at control voltage U _s ±10%							
make time ms	7 - 16	7 - 16	9 - 15	17 - 24	11 - 15	11 - 15	-
release time ms	6 - 12	6 - 12	4 - 8	17 - 23	6 - 13	6 - 13	-
arc duration ms	10 - 15	10 - 15	10 - 15	10 - 15	10 - 15	10 - 15	-
Cable cross-sections							
Main connector solid or stranded mm ²	1,5 - 10	1,5 - 10	1,5 - 10	1,5 - 10	2,5 - 25	2,5 - 25	0,5 - 2,5 ³⁾
flexible mm ²	1,5 - 6	1,5 - 6	1,5 - 6	1,5 - 6	2,5 - 16	2,5 - 16	0,5 - 2,5 ³⁾
flexible with multicore cable end mm ²	1,5 - 6	1,5 - 6	1,5 - 6	1,5 - 6	2,5 - 16	2,5 - 16	0,5 - 1,5
Clamps per pole	1	1	1	1	1	1	2
Magnetic coil solid or stranded mm ²	0,75 - 2,5	0,75 - 2,5	0,75 - 2,5	0,75 - 2,5	0,75 - 2,5	0,75 - 2,5	-
flexible mm ²	0,5 - 2,5	0,5 - 2,5	0,5 - 2,5	0,5 - 2,5	0,5 - 2,5	0,5 - 2,5	-
flexible with multicore cable end mm ²	0,5 - 1,5	0,5 - 2,5	0,5 - 1,5	0,5 - 1,5	0,5 - 1,5	0,5 - 1,5	-
Clamps per pole	1	1	1	1	1	1	-
Auxiliary Contacts ^{5) 6) 7)}							
Rated insulation voltage U _i ¹⁾ V AC	-	-	-	-	-	-	440 ²⁾
Thermal rated current I _{th} 40°C A	-	-	-	-	-	-	10
Ambient temperature 60°C A	-	-	-	-	-	-	6
Utilization category AC15							
Rated operational current I _e 220-240V A	-	-	-	-	-	-	3
380-415V A	-	-	-	-	-	-	2
440V A	-	-	-	-	-	-	1,6
Utilization category DC13							
Rated operational current I _e 24-60V A	-	-	-	-	-	-	2
110V A	-	-	-	-	-	-	0,4
per pole 220V A	-	-	-	-	-	-	0,1
Short circuit protection							
short-circuit current 1kA, contact welding not accepted	-	-	-	-	-	-	-
max. fuse size gL (gG) A	-	-	-	-	-	-	10

Data according to UL508

Main Contacts (cULus)	Type	R20	R25 (2p.)	R25 (4p.)	R40	R63	RH11
Rated operational current "General Use"	A	20	25	25	40	63	10
Rated operational power of three-phase motors at 60Hz (3ph)	110-120V hp	-	-	1	2	3	-
	200-208V hp	-	-	2	5	7½	-
	220-240V hp	-	-	3	7½	10	-
	265-277V hp	-	-	3	7½	10	-
Rated operational power of AC motors at 60Hz (1ph)	110-120V hp	½	½	½	1	1½	-
	200-208V hp	1	1	1	2	3	-
	220-240V hp	1½	1 ½	1½	3	5	-
	265-277V hp	1½	2	2	3	5	-
Fuses Suitable for use on a capability of delivering not more than	A	40	40	40	80	80	-
	rms A	5000	5000	5000	5000	5000	-
	V	300	300	300	300	300	300
Rated operation voltage	V~	300	300	300	300	300	300
Auxiliary Contacts (cULus)	heavy pilot duty AC	-	-	-	-	-	C300

2) Suitable for: earthed-neutral systems, overvoltage category I to III, pollution degree 3 (standard-industry): U_{imp} = 4kV.

3) Maximum cable cross-section with prepared conductor 4) AC7b motor 2-pole 230V 1,1kW

5) Rated frequency 50/60Hz

6) Max. occ. switching overvoltage <4kV

7) Duty cycle: 100%

Modular Contactors

Dimensions

R20-.., R25-.. (2-pole)
RC-R 230, RH25-20

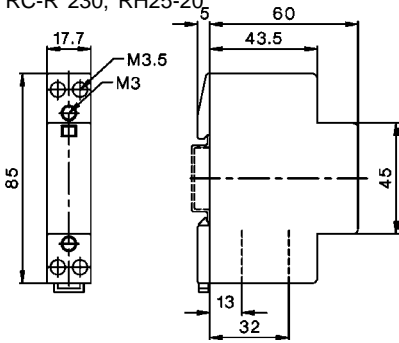

R25-TN

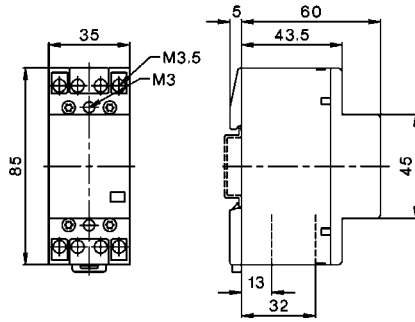

R25-.. (4-pole) (+RH11)
R25-..VM (+RH11-1)

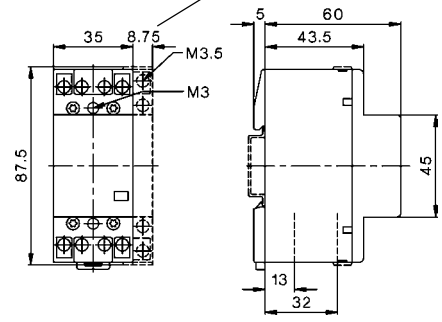

R40-.. (2-pole)
R63-.. (2-pole)

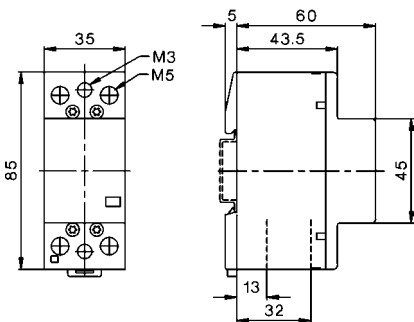

R40-.. (4-pole) (+RH11)
R63-.. (4-pole) (+RH11)

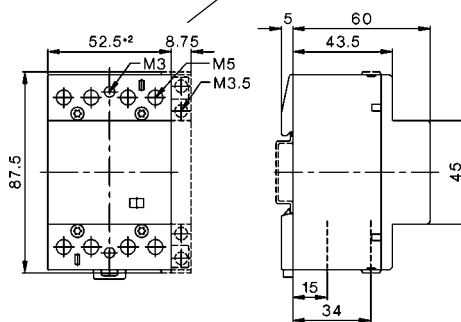

Aux. contact block
RH11, RH11-1

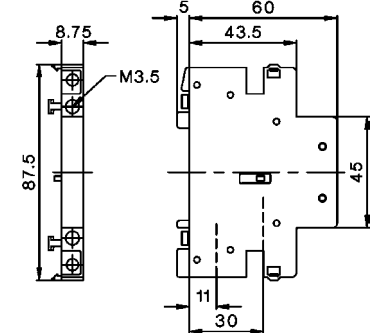

European Representations and Suppliers

Belgium

+32

Teconex
Material Electrique
Rue de Magnee 108
B - 4610 Beyne-Heusay

Tel: 04 / 355 88 26
Fax: 04 / 358 21 97
info@teconex.be
www.teconex.eu

Bulgaria

+359

Schrabul Ltd
Yordan Yovkov Str. 8
BG - 1408 Sofia

Tel: 02 / 958 76 54
Fax: 02 / 958 59 95
schrabul@otel.net

Cyprus

+357

M. Hadjioannou Ltd.
Electrotechnical & Lighting Specialists
Aegeos 8c, Pallouriotissa
CY - Nicosia

Tel: 22 / 348 262
Fax: 22 / 430 107
milton@spidernet.com.cy

Denmark

+45

MTO electric a/s
Andkaervej 26
DK - 7100 Vejle

Tel: 075 / 800 310
Fax: 075 / 800 320
mav@mto-electric.dk
www.mto-electric.dk

Finland

+358

UTU Powel Oy
Palopellonkatu 7
PL 33
FIN - 04251 Kerava

Tel: 09 / 274 64 11
Fax: 09 / 274 64 141
komponentit@urhotuominen.fi
www.urhotuominen.fi

France

+32

Teconex
Material Electrique
Rue de Magnee 108
B - 4610 Beyne-Heusay

Tel: 04 / 355 88 26
Fax: 04 / 358 21 97
info@teconex.be
www.teconex.eu

Germany

+49

Rudolf Kiesewetter
Messtechnik GmbH
Prager Strasse 34
D - 04317 Leipzig
Representation for Postleitzahlgebiet 0

Tel: 0341 / 550 16 06
Fax: 0341 / 550 16 09
info@kiesewetter-mt.de
www.kiesewetter-mt.de

TVB GmbH

Büro für Elektroanlagen u. Geräte
Hartje Rüterweg 88
D - 22399 Hamburg
Representation for Postleitzahlgebiete 1, 2 and 3

Tel: 040 / 608 750 22
Fax: 040 / 608 750 23
info@tvb-hamburg.de
www.tvb-hamburg.de

Wagner GmbH

Werksvertretungen d. Elektroind.
Robert Bosch Straße 35
D - 42489 Wülfrath
Representation for Postleitzahlgebiete 4 and 5

Tel: 02058 / 782 800-0
Fax: 02104 / 752 800-49
info@wagnergmbh.de
www.wagnergmbh.de

Wilhelm Becker

Elektro-Handelsvertretung
Zum Köpperner Tal 17
D - 61381 Friedrichsdorf-Burgholzhausen
Representation for Postleitzahlgebiete 6 and 7

Tel: 06175 / 798 194
Fax: 06175 / 798 195
info@becker-ehv.de
www.becker-ehv.de

SBV - Gawehn GmbH

Industrieververtretungen
Zollnerstraße 2
D - 90579 Langenzenn
Representation for Postleitzahlgebiete 8 and 9

Tel: 09101 / 9099-0
Fax: 09101 / 9099-30
vertrieb@gawehn.com

European Representations and Suppliers

Great Britain	+44
IMO Precision Controls Ltd. 1000 North Circular Road GB - NW2 7JP London	Tel: 020 / 8452 6444 Fax: 020 / 8450 2274 imo@imopc.com www.imopc.com +30
Greece	
Geyer Hellas s.a. Electrical And Electronic Material PO Box 19038 GR - 34100 Drosia-Chalkis	Tel: 22210 / 987 11 Fax: 22210 / 987 12 info@geyer.gr www.geyer.gr
Hungaria	+36
Dial-Comp GmbH Keszkeno u. 46/b. H - 1131 Budapest	Tel: 01 / 236 0427 Fax: 01 / 236 0430 dialcomp@dialcomp.hu www.dialcomp.hu
Italy	+39
SIF Trading Via Per Curnasco 64 I - 24127 Bergamo	Tel: 035 / 258 853 Fax: 035 / 258 011 info@sifmdc.com
Netherlands	+31
Hirsch-Driebergen B.V. Postbus 143 NL - 3970 AC Driebergen	Tel: 0343 / 515 534 Fax: 0343 / 520 314 info@hirsch-driebergen.nl www.hirsch-driebergen.nl
Norway	+47
Gylling Teknikk AS P. O. Box 103 Rudssletta 71 N - 1351 Rud	Tel: 67 / 15 14 00 Fax: 67 / 15 14 01 gylling@gylling.no www.gylling.no
Poland	+48
ASTAT Sp. z o.o. Ul. Dabrowskiego 441 PL - 60-451 Poznan	Tel: 61 / 848 88 71 Fax: 61 / 848 82 76 info@astat.com.pl www.astat.com.pl
Automatech Sp. z o.o. Ul. Ryzowa 84 PL - 05-816 Opacz-Kolonia	Tel: 22 / 723 06 62 Fax: 22 / 723 06 06 biuro.warszawa@automatech.pl www.automatech.pl
Dukat Sp. z o.o. Ul. 20 Stycznia 95/5 PL - 95-200 Pabianice	Tel: 422 / 152 571 Fax: 422 / 152 571 jadwiga@dukatad.pl www.dukatad.pl
Portugal	+351
Jayme da Costa Mecanica e Electricidade, S.A. Rua de Murraceses, 216 P - 4416 - 901 Pedroso	Tel: 22 / 74 70 250 Fax: 22 / 76 40 548 ae@jaymedacosta.pt www.jaymedacosta.pt

Romania	+40
ImSAT International SA Str. Episcop Radu nr. 15A sect. 2, cod 72159 RO - 76548 Bukarest	Tel: 01 / 210 25 81 Fax: 01 / 210 30 35 office@imsatint.ro www.imsatint.ro
Russia	+7
Torgoviy Dom ChEAZ ChEAZ Trading House LLC 16/1ul. Dokukina, Moskau RU-129226 Russia	Tel: 095 / 99 53 100 Fax: 095 / 99 53 200 cheaz@tsr.ru www.cheaz.ru
DIAL Electrolux Ltd. Bld. 1, Block2, Fl. 7 131 Deguninskaia St., Moscow RU-127486 Russia	Tel: 495 / 48 73 350 Fax: 495 / 48 73 654 add. 131 sales@dialectrolux.ru www.dialectrolux.ru
Spain	+34
Cydesa Construcciones y Distribuciones, Eléctricas, S.A. C.Poligono Industrial Sant Antoni Parcela 2 Nave A E - 08620 Sant Vicenc Dels Horts Barcelona	Tel: 93 / 656 59 50 Fax: 93 / 656 65 59 cydesa@cydesa.com www.cydesa.com
Sweden	+46
Wallin & Co AB Götlundagatan 10 Box 420 S - 12404 Bandhagen	Tel: 8 / 860 102 Fax: 8 / 997 050 wallin@alfa.telenordia.se www.wallin-co.se
Switzerland	+41
Benedict Swiss AG Grindelstraße 19 CH - 8303 Bassersdorf	Tel: 44 / 213 66 00 Fax: 44 / 213 66 09 office@benedict-swiss.ch www.benedict-swiss.ch
Serbia and Montenegro	+381
Elektro-Koil d.o.o. Ulica Breza 9/13 SRJ-11136 Belgrad	Tel: 11 / 75 71 906 Fax: 11 / 75 42 931 office@elektrokoil.rs www.elektrokoil.rs
Turkey	+90
Ergun Elektrik Co Ltd. Kazim Dirik Mahallesi Sanayi Caddesi No: 66 Bornova, Izmir 35100 TURKEY	Tel: 01 / 236 0427 Fax: 01 / 236 0430 ergun@ergunelektrik.com www.ergunelektrik.com

Oversea Representations and Suppliers

Australia +61

BRIDEX-ETS PTY LTD
Unit 12
20 Narabang Way
NSW 2085 Berlose
AUS
Tel: 02 / 9986 17 11
Fax: 02 / 9986 17 66
sales@bridex-ets.com.au
www.bridex-ets.com.au

Bolivia +591

Agencias Generales S.A.
Casilla de Correo 530
Av. San Martin
BO - 0253 Cochabamba
Tel: 04 / 425 10 62
Fax: 04 / 425 10 61
agsa@supernet.com.bo
www.agsa.com

Canada +1

Brook Crompton Ltd.
264 Attwell Drive
Toronto, ON
CDN - M9W 5B20 Ontario
Tel: 0416 / 675 38 44
Fax: 0416 / 675 68 85
david.tomlinson@btrinc.com

Egypt +20

Economic Co.
Electrical Commerce & Import
44, Naguib El-Rihani St.
ET - Kairo
Tel: 02 / 592 91 80
Fax: 02 / 590 78 82
economic77@hotmail.com

Hong Kong +852

**Creation Building Services
Materials Limited**
5st Floor, Hing Yip Centre
37 Beech Street, Tai Kok Tsui
HK-Kowloon
Hong Kong - China SAR
Tel: 2408 3333
Fax: 2191 5510
sales@ysh.com.hk
www.ysh.com.hk

Iran +98

Nader Pardaz Co.
Unit 12, 6 Floor, No.12,
Bahar Shiraz St.
Tehran-Iran
Tel: 21/77631517
Tel: 21-77509555
info@naderpardaz.ir
www.naderpardaz.ir

Israel +972

Gino Industries Ltd.
3, Ophir Street
IL - 32235 Haifa
Tel: 03 / 687 92 66
Fax: 03 / 688 26 91
gino-ind@actcom.co.il
www.gino-ind.com

Kenya +254

G.F. Corvin Ltd.
P.O. Box 30747
00100 Nairobi
EAK Kenya
Tel: 02 / 802 908
Fax: 02 / 802 956
moeller@nbi.ispkenya.com

Mexico +52

B&J USA Inc.
120-101 North Tech Drive
Post Office Box 877
Clayton, N.C. 27528
Tel: 919/553 5501
Fax: 919/553 5565
sales@bnj-usa.com
www.bnj-usa.com

New Zealand +64

Eurotec Instruments Ltd.
P.O.Box 14-543 Panmure
750 Gt South Rd, Penrose
NZ - Auckland
Tel: 09 / 579 1990
Fax: 09 / 499 36 96
sales@eurotec.co.nz
www.eurotec.co.nz

Singapore and Malaysia +65

Mecomb Singapore Ltd.
#04-02 Sime Darby Centre
896 Dunearn Road
SGP - 589472 Singapore
Tel: 646 98 833
Fax: 646 71 905
sales.msl@simedarby.com.sg

South Africa +27

Deebar
Mining & Ind. Supplies
P.O. Box 40325
RSA - 2022 Cleveland
Tel: 021 / 873 43 32
Fax: 021 / 825 69 84
sales@deebaar.co.za

Electric Assemblies
Unit 2A Simplex Ind. Park
Engine Road,
RSA - 7441 Cape Town
Tel: 021 / 52 3023
Fax: 021 / 52 2704
davecpt@mweb.co.za

Syria +963

T. S. Boyadjian
Electrical Equipments
Halbouni Street no. 9
P.O. Box 2822
SYR - Damaskus
Tel: 011 / 221 14 45
Fax: 011 / 221 67 45
tsboyadjian@excite.com

Taiwan +886

Vinmajor Enterprise Co., Ltd.
8F-2, No. 306, Section 1
Ta-Tung Road, Hsi-Chih
Taipei Hsien, Taiwan
R.O.C.
Tel: 02 / 2643 6183
Fax: 02 / 8691 6288
vin.major@msa.hinet.net

U.A.E. +971

Doepke International Trading LLC
Carrera Building - Karama
Suite 206, 2nd Floor
P.O.Box:48767 Dubai
Tel: 04 / 33 62 880
Fax: 04 / 33 62 890
doepke@emirates.net.ae
www.doepke.de

USA +1

B&J USA Inc.
120-101 North Tech Drive
Post Office Box 877
Clayton, N.C. 27528
Tel: 919/553 5501
Fax: 919/553 5565
sales@bnj-usa.com
www.bnj-usa.com

Zimbabwe +263

Star Delta Electrix
Cnr 11th Ave and Fife Str.
P.O. Box 3592
ZW - Bulawayo
Tel: 9 / 715 24
Fax: 9 / 776 18
stardb@mweb.co.zw

Star Delta Electrix
Graniteside Way, Harare
P.O. Box 2753
ZW - Harare
Tel: 4 / 754 792/8-28
Fax: 4 / 754 790
stardh@mweb.co.zw

Alphabetical Index

Description	Type	Page	Description	Type	Page
Additional Terminals for Contactors	LG..	37	Electronic Timer Off-delay	K2-TA..	35
for D.O.L. Starters	LG..	97	Electronic Timer On-delay	K2-TE..	35
for Star-Delta Starters	LG..	77	Electronic Timer for Star-Delta Starters	Y9..	77
for Thermal Overload Relays	LG..	105	Enclosures for Contactors	P1	97
Auxiliary Contact Blocks for Contactors K1-07	HK..	8	Enclosures for D.O.L. Starters	P1R	97
for Contactors K1-09, -12	HKM..	10, 14			
for Contactors K3	HA..	22, 34	Feeder Groups for Contactors K3	K3-../FG...	40
for Contactors K3	HB11	34	Fourth Pole for Contactors K3	NP..	37
for Contactors K3	HN..	22, 34	Fuse Holders	K2-F	36
for Contactors K3	HK..	34			
for Contactors R..	RH11	117	Heating Element for D.O.L. Starters	K2-HR	97
Busbar Sets for Thermal Overload Relays	SU840/...	99			
Capacitor Switching Contactors	K3-18K..	33	Indicator Units, Coil Current Indicator	K2-IN..	36, 97
	K3-24K..	33	Indicator Units, Lens Caps for Indicator Units	LG9743..	97
	K3-32K..	33	Indicator Units, Voltage Indicator	K2-UN..	36, 97
	K3-50K..	33	Interface	K2-IM	36
	K3-62K..	33			
	K3-74K..	33	Latch	K2-L..	36
	K3-90K..	33			
	K3-115K..	33	Marking Systems for Contactors	LG.., P...	38
Coil Voltage Ranges for Contactors K1		12	Mechanical Interlock	LG..	37
for Contactors K3		39	Mini Contactor Relays	K1-07D..	8
Contactor Relays, AC Operated	K3-07..	20, 21	Mini Contactors	K1-09..	10
Contactor Relays, DC Operated	KG3-07A..	21		K1-12D..	10
Contactors, AC and DC Operated	K3-10A..	30, 31		K1-09F..	12
	K3-14A..	30, 31		K1-09L..	12
	K3-18A..	30, 31	Mini Reversing Starters	K1W09D..	14
	K3-22A..	30, 31		K1W12D..	14
	K3-24A..	30, 31		K1W09L..	14
	K3-32A..	30, 31	Modular Contactors	R20..	116
	K3-40A..	30, 31		R25..	116
	K3-50A..	30, 31		R40..	116
	K3-62A..	30, 31		R63..	116
	K3-74A..	30, 31	Momentary Contacts for Contactors K2	HTN..	34
	K3-90A..	30, 31	Mounting Bar for Electronic Timer Y9..	LG7735	77
	K3-115A..	30, 31	Mounting Parts for Contactors	K2-..SM, P...	36, 38
	K3-151A..	30, 31			
	K3-176A..	30, 31	Parallel Connectors	LG..	38
	K3-210A..	30, 31	Pneumatic Timer	K2-TP..	35
	K3-260A..	30, 31	Pole Changing Starters Open Type	K3PU..	80
	K3-316A..	30, 31	Pole Changing Starters Steel Sheet Enclosed	K3PU..B	80
	K3-450A..	30, 31			
	K3-550A..	30, 31	Rectifier with Fuse Holder	K2-RF..	36
	K3-700A..	30, 31	Reversing Starters Connector	K1W-VB	14
	K3-860A..	30, 31		K3W-VB..	78
	K3-1000A..	30, 31	Reversing Starters Open Type	K3WU..	78
	K3-1200A..	30, 31		KW3-..	80
Contactors, DC Solenoid Operated	KG3-10A..	31	Reversing Starters Steel Sheet Enclosed	K2WU..B	78
	KG3-14A..	31			
	KG3-18A..	31	Sets for Single Mounting Thermal Overload Relays	U12SM	105
	KG3-22A..	31		U3/32SM	105
	KG3-24A00	32		U3/42G	105
	KG3-32A00	32	Spare Contacts for Contactors	EK../..	42
	KG3-40A00	32	Spare Coils for Contactors	K../4..	40, 41
Contactors 4-pole	K3-10A00-40	32	Star-Delta Starter Connector	K3Y-VB..	77
	K3-14A00-40	32	Star-Delta Starters Open Type	K3Y..	74
	K3-18A00-40	32	Star-Delta Starters Plastic Enclosed Type	K3Y..P	76
	K3-22A00-40	32	Star-Delta Starters Steel Sheet Enclosed Type	K3Y..B	76
	K2-23A00-40	32	Suppressor Units, RC-units	RC-K1	10
	K2-30A00-40	32	RC-units	RC-K3	38
	K2-37A00-40	32	RC-units	RC-R..	117
	K2-45A00-40	32			
	K2-60A00-40	32	Terminal Block (2 term. insulated) f. Contactors K2	K2-SK	34
	K3-116A00-40	32	Terminal Block (2 term. interconn.) f. Contactors K2	K2-DK	34
	K3-151A00-40	32	Terminal Covers for Contactors	LG..	37
	K3-176A00-40	32	Thermal Overload Relays	U12/16A .. K1	102
	K3-210A00-40	32		U12/16E .. K1	102
	K3-260A00-40	32		U12/16EQ .. K1	102
	K3-316A00-40	32		U12/16E .. K3	103
				U12/16EQ .. K3	103
D.O.L. Starters with Start-Stop Push Buttons	P1T, K2U..PT	96		U3/32 ..	74,103
D.O.L. Starters with Selector Switch	P1W, K2U..PW	96		U3/42 ..	74,103
D.O.L. Starters with Selector and Pneumatic Switch	P1W18P	96		U3/74 ..	75,104
				U85 ..	75,104
				U180 ..	75,104
				U320 ..	104
				U800 ..	104
			with Slow Tripping Characteristic	UAT..	104