

Parafoudres

Προστασία

Сетевые протектор

突波保護

Surge

サージ保護

Piekstroombeveiliging

Parafoudres

Сетевые протектор

Überspannungsschutz

Protection

Προστασία

Сетевые протек

gsschutz

突波保護

Protección Sobretensión



Édition 1.0



CITEL



Table of Contents

History	3
General Overview	4



AC Surge Protection

AC Overview	8
DS250VG	11
DS150E	12
DS130	13
DS70R	14
DS40	15
DS215 / DS240	16
DS415 / DS440	17
DS220DC / DS230DC / DS240DC	18
DS210DC	19
DS-HF	20
M Series	21
MSB	22



Photovoltaic Surge Protection

Photovoltaic Overview	23
DS60VGPV	24
DS50VGPV	25
DS50PV/51	26



Telecom & Data Line Surge Protection

Telecom & Data Line Overview	27
DLA / DLA2	28
DLU / DLU2	29
B180 / B280 / B480	30
DD	31
MJ8 / MJ6	32
MJ8-CAT5 / MJ8-C6	33
MJ8-POE	34
CMJ8-POE	35
RAK	36



Coaxial Surge Protection

Coaxial Overview	37
P8AX	38
P8AX-6G	39
PRC	40
CXF60-N	41
CXC / CNP	42



Gas Discharge Tubes

Gas Discharge Tube Overview	43
Gas Discharge Tube Selector	45





CITEL History

Who is Citel - The leading specialist in overvoltage Protection!

Citel is an international group established in 1937 that specializes in the manufacture and sales of Surge Protective Devices (SPD) and Gas Discharge tubes (GDT) to its worldwide customers. These devices protect sensitive electronic equipment and staff from destructive transient over voltages originating from lightning strikes and electrical disturbances.

Citel manufactures two types of products,

- **Gas Discharge Tubes (GDT)** or Surge Arrestor components for Printed Circuit Board (PCB) level applications.
- **Surge Protective Devices (SPD)** or Transient Voltage Surge Suppressor (TVSS) modules and stand alone devices for original equipment manufacturers, integrators and end users.

Citel is unique as both a manufacturer of surge arrestor components and their deployment across a full range of Surge Protective Devices for AC power, DC power, telecom & data line and RF coaxial applications. This core skill provides Citel with an matchless ability to develop high performance products that deliver consistent results for any international standard or specific customer application.

Citel's major customers are found among the top companies within the renewable energy, electric utility, oil & gas, process chemical, telecommunication, water & wastewater treatment, government, military, and commercial/industrial markets.

A long history...

- 1937** - Citel founded as a manufacturer of lighting tubes.
- 1944** - Citel manufactures first Gas Discharge Tube (GDT).
- 1976** - Citel acquired by current ownership group. Manufacture of lighting tubes discontinued.
- 1985** - Citel Incorporated established in Miami, Florida USA.
- 1988** - Citel GmbH established in Düsseldorf, Germany.
- 1992** - Citel acquires GDT competitor Claude from GTE Sylvania.
- 1996** - Citel Shanghai Electronics established in Shanghai, China (Manufacture of GDT, AC & DATA Modules).
- 1998** - Citel-2CP goes public on the Paris Stock Exchange.
- 2000** - Launched the first MOV-GDT Hybrid SPD for AC Type 1 applications based on patented VG technology.
- 2005** - Launched full photovoltaic range for DC Type 1 (DS60PV), Type 2 (DS50PV) and Type 3 (DS210.DC).
- 2006** - Citel-2CP sells seat on the Paris Stock Exchange and is privately held.
- 2007** - Launched Din rail pluggable data-line surge protectors - DLA Series.
- 2008** - Headquarters moved to Sèvres, a district of Paris, France.
- 2008** - Launched P8AX Series coaxial surge protectors with standard waterproof, bulkhead, GDT holder options.
- 2009** - Launched best performing 6 GHz coaxial surge protector - P8AX-6G Series.
- 2009** - Launched smallest 2- and 3-Electrode (4.4mm) Surface Mount GDT with Square Electrodes.
- 2009** - Citel AC & DC Power Line products approved to UL1449 3rd edition.
- 2010** - Citel acquires Cylix Corporation, manufacturer of Data Line Surge Protectors.
- 2010** - Citel Russia established in Moscow, Russia.



General Overview

OVERVIEW OF TRANSIENT OVERVOLTAGES

The users of electronic equipment, telephone and data-processing systems must face the problem of keeping this equipment in operation in spite of transient overvoltages induced by lightning.

There are several reasons:

- The high level of integration of electronic components makes the equipment more vulnerable.
- Interruption of service is unacceptable.
- Data transmission networks cover large areas and are exposed to more disturbances.

THE ORIGIN OF OVERVOLTAGES

Transient overvoltages have three main causes:

- Lightning
- Switching surges
- Electrostatic discharges (ESD)

The overvoltages of different origins differ in amplitude, frequency and duration.

LIGHTNING

Lightning, investigated since Benjamin Franklin's first research in 1749, has paradoxically become a growing threat to our highly electronic society.

Lightning formation

A lightning flash is generated between two zones of opposite charge, typically between two storm clouds or between one cloud and the ground.

The flash may travel several miles, advancing toward the ground in successive leaps: the leader creates a highly ionized channel. When it reaches the ground, the real flash or return stroke takes place.

A current in the tens of thousands of Amperes will then travel from ground to cloud or vice versa via the ionized channel.

Direct effects of lightning

At the moment of discharge there is an impulse current flow that ranges from 1,000 to 200,000 Amperes peak, with a rise time of only a few microseconds. Direct lightning strikes are rarely but devastating events. Typically, protection is provided by a lightning rod or a lightning protection system (LPS) that is designed to capture the lightning discharge current and conduct it safely to ground.

INDIRECT EFFECTS OF LIGHTNING

There are three types of indirect lightning effects:

Impact on overhead line

Overhead utility lines are very exposed and may be struck directly by lightning. These events can be catastrophic and either partially or completely destroy the cables, which then causes high surge voltages that travel naturally along the conductors to line-connected equipment. The extent of the damage depends on the distance between the strike point and the equipment.

Rise in ground potential

The flow of lightning in the ground causes earth potential increases that vary according to the current intensity and the local earth impedance. In an installation that may be connected to several grounds (e.g. link between buildings), a strike will cause a very large potential difference and equipment connected to the affected networks will be destroyed or severely disrupted.

Electromagnetic radiation

The flash may be regarded as an antenna several miles high carrying an impulse current of several tens of kilo-amperes, radiating intense electromagnetic fields (several kV/m at more than 1 km). These fields induce strong overvoltages and overcurrents in lines near or on equipment. The values depend on the distance from the flash and the properties of the link.

SWITCHING SURGES

This term covers phenomena caused by switching electric power sources. Switching surges are caused by:

- Starting motors or transformers
- Neon and sodium light starters
- Switch "bounce" in an inductive circuit
- Operation of fuses and circuit breakers

These phenomena generate transients of several kV with rise times in the order of microseconds, disturbing equipment in networks to which the source of disturbance is connected.

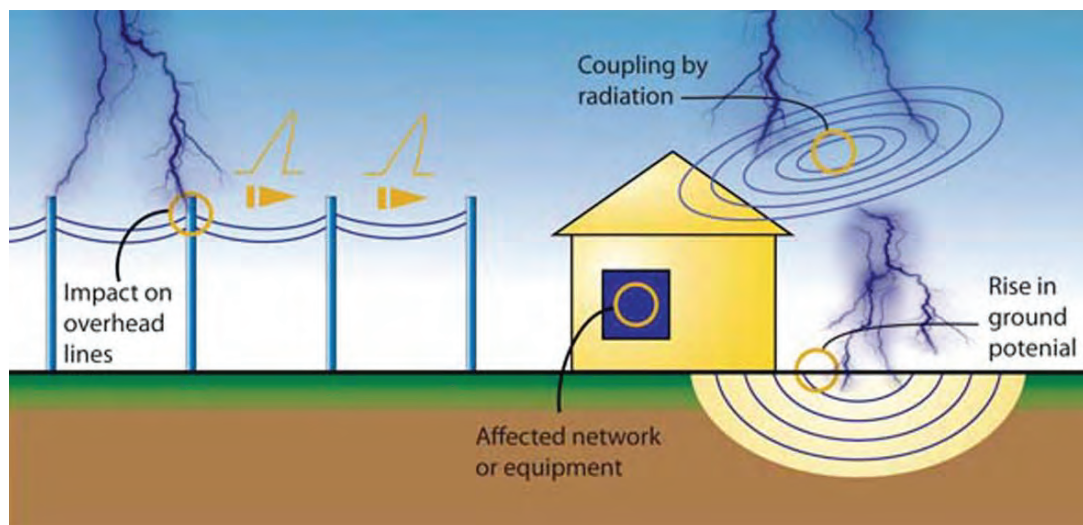



General Overview

Electrostatic overvoltages (ESD)

Electrically, a human being has a capacitance ranging from 100 to 300 picofarads, and can pick up a charge as much as 15 kV i.e. by walking on carpet, then touch some conducting object and can be discharged in a few nanoseconds, with a current of about ten Amperes. All integrated circuits (Complementary Metal Oxide semiconductor(CMOS), etc.) are quite vulnerable to this kind of disturbance, which is generally eliminated by shielding and grounding.

EFFECTS OF OVERVOLTAGES

Overvoltages have many types of effects on electronic equipment in order of decreasing importance:

Destruction

- Voltage breakdown of semiconductor junctions
- Destruction of bonding of components
- Destruction of tracks of PCBs or contacts
- Destruction of triacs/thyristors by dV/dt .

Interference with operation

- Random operation of latches, thyristors, and triacs
- Erasure of memory
- Program errors or crashes
- Data and transmission error

Premature ageing

Components exposed to overvoltages have a shorter life.

SURGE PROTECTION DEVICES

The Surge Protective Device (or SPD: generic name for any device that protects against voltage surges) is a recognized and effective solution to the overvoltage problem for any of power or telecom, data, or signal networks.

The SPD will be applied between the thread (external network) and the possible victim (sensitive equipment) and will be wired between active wires and bonding network. For greatest effectiveness, however, the SPD must be chosen according to the risk and installed in accordance with the international guides or the local electric codes.

STANDARDS

Because of the diversity and importance of transients, standard organizations have created specifications for testing the susceptibility of equipment to overvoltages, and for evaluating the effectiveness and safety of the surge protectors.

The phenomena were first characterized, and a series of standardized waves created (1.2/50 μ s voltage impulse, 8/20 μ s and 10/350 μ s current impulses), then a number of standards defining SPD performance were issued, among them:

Surge Protectors for low-voltage AC installations

- IEC 61643-11 (International)
- UL 1449 3rd Edition-Surge Protective Devices (USA)
- ANSI/IEEE C62.41 (USA)
- EN 61643-11 (Europe)

Surge Protectors for PV installations

- EN 50539-11 (Europe)
- UTE C 61-740-51 (France)
- UL 1449 3rd Edition-DC Rated SPD's (USA)

Guides for AC Surge protector installation

- IEC 60364-4-443 and 5-534 (International)
- IEC 61643-12 (International)
- IEC 62305 series (International)
- IEEE C62-72 (USA)
- NEC art. 280&285 (USA)
- GB 50343 (China)
- HD 4-443 and 5-534 (Europe)

Surge Protectors and recommendations for telecom, data and coaxial line equipment

- IEC 61643-21 (International)
- ITU-T K series recommendations (International)
- UL 497A/B/E (USA)
- FCC Part 68 (USA)



Citel AC Power Surge Protector

Application field



Application in standard electrical cabinets in compliance with international standard.

DS Range from CITEL

A pluggable design

The design of most DS surge protectors is based on the use of a module to plugged into a matching base.

This makes replacement and checking very easy without impairing your protection.

For multipole surge protectors, the possibility of replacing a single pole makes rehabilitating a surge protector less expensive.

The plug-in module is identified with a color label in relation with the type (black=Type 1; red=Type 2; blue=low power Type 2 or Type 3) and are keyed for operating voltage, in order to avoid misapplications.

DIN Rail mounting

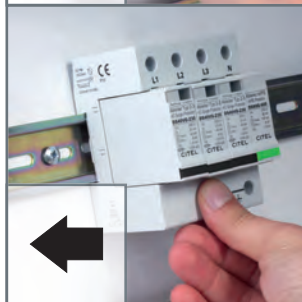

Slide the surge protector into the rail, and press until the unit fits and snaps.

Dismantling

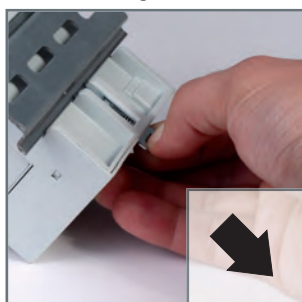

Pull the assembly clamp, and remove the device.



Plug-in Module

All modules are marked with characteristics and major approval stamps.





Citel AC Power Surge Protector



Identified connections

All connections are identified, this facilitates an error-free installation.

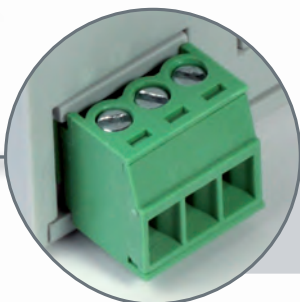

Remote signaling

Less wiring thanks to a single remote signaling connector for all poles.

Signaling

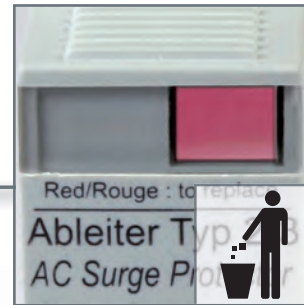

Defective modules are identified by red indicator in the front window. It is then necessary to change them.

Module replacement

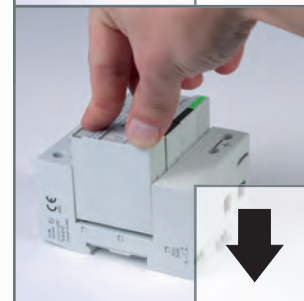
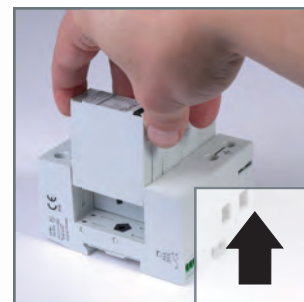

Easy module replacement, requiring no tools, thanks to the pluggable modules.

Module codification

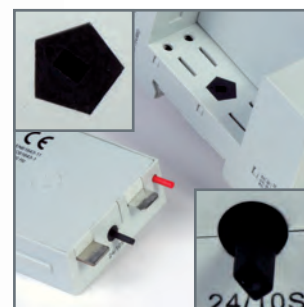

Mistake-free replacement thanks to an explicit and mechanical codification for the different operating voltages.





AC Overview

SURGE PROTECTORS FOR AC POWER LINES

CITEL AC power Surge Protective Devices are designed to meet all surge protection needs for low voltage installations. Designed for mounting on DIN rails, these protectors are easy to install in standardized panels and cabinets, and are equipped with thermal disconnection devices and indicators allowing total operating safety.

CITEL AC power surge protectors offer three levels of surge protection corresponding to different IEC or EN classes. They are available with several protection diagrams and configurations to comply with different installation needs and international standard requirements. CITEL AC power surge protectors offer three types of surge protection corresponding to different IEC or EN classes.

STANDARDS COMPLIANCE

To ensure efficient and reliable performances, all CITEL's AC power surge protectors comply with the leading standards:

- Europe : EN61643-11
- International : IEC61643-11
- USA : UL1449-3rd edition

Those standards are dividing AC surge protectors in "types" but the meaning are different for EN/IEC and for UL.

EN61643-11 and IEC61643-11 standards

These standards, almost equivalent, have defined 3 types of AC surge protectors, depending of the class of tests applied.

Type 1 Surge Protectors

Type 1 surge protectors are designed to be installed where a direct lightning strike risk is high, especially when the building is equipped with external lightning protection system (LPS or lightning rod). In this situation, EN 61643-11 and IEC 61643-11 standards require the Class I test to be applied to surge protectors : this test is characterized by the injection of 10/350µs impulse current in order to simulate the direct lightning strike consequence. Therefore these Type 1 surge protectors must be especially powerful to conduct this high energy impulse current.

Type 2 Surge Protectors

Type 2 surge protectors are designed to be installed at the origin of the installation, in the main switchboard, or close to sensitive terminals, on installations without LPS (lightning rods). These protectors are tested following the Class II test from IEC61643-11 or EN61643-11 standards and based on 8/20µs impulse current injection.

Type 3 Surge Protectors

In case of very sensitive or remote equipment, secondary stage of surge protectors is required : these low energy SPDs could be Type 2 or Type 3. Type 3 SPDs are tested with a combination waveform (1,2/50 µs - 8/20 µs) following Class III test.

Type 1+2+3 Surge Protectors

Some SPDs, especially VG technology, are tested following several classes and have the same protection efficiency as an association of 2 or 3 stages of classical SPDs : they are described as "1+2" or "1+2+3" types.

UL1449 3rd edition

This US standard have defined 5 types of AC surge protectors, depending of their application on the AC network location and their construction.

Application on AC network

Type 1

SPDs permanently connected to AC, upstream or downstream the main breaker. No additional protection (Fuse) required.

Type 2

SPDs permanently connected to AC, only downstream the main breaker. Located on the Main Electrical Board or secondary panel.

Type 3

SPDs installed close the sensitive equipment, more then 10 m away from the Main Electrical Board.

SPD construction

Type 4

« Component assembly ». Type 4 SPD are made with several Type 5 (Components) with a disconnection feature (external or internal).

Type 5

Discrete Components, as MOV, GDT..to be mounted on PCB or connected by wire

Guides for AC surge protector installation :

These following documents give the main information about AC power surge protectors, their selection and their proper installation:

- International : IEC 61643-12 and IEC 62305-4
- Europe : CLC/TS 61643-12
- USA : IEEE C62-72



AC Overview

SURGE PROTECTORS PARAMETERS

AC Surge protectors are defined by some electrical specifications which will help the user to select the right protection specific to their installation:

Operating voltage - U_c

The maximum continuous operating voltage (MCOV) U_c is the maximum AC voltage which may be applied continuously to the SPD.

Temporary overvoltage - U_T

The temporary overvoltage U_T (TOV) is the AC voltage the surge protector can withstand during 5 seconds, without failure.

Discharge currents - I_n and I_{max}

The maximum discharge current (I_{max}), applicable to Type 2 SPD, is the maximum impulse current $8/20 \mu s$ a surge protector can withstand without destruction.

The nominal discharge current (I_n) is the level of impulse current a surge protector Type 1 or Type 2 can withstand repeatedly (15 surges) without destruction.

Impulse current - I_{imp}

The impulse current (I_{imp}), used in Class I test applicable to Type 1 SPDs, is the maximum impulse $10/350 \mu s$ current a surge protector can withstand without destruction. This test simulates the effect, on AC power surge protectors, of a direct lightning strike on an installation.

Open circuit voltage - U_{oc}

This parameter is used only for Class III test, applicable to Type 3 SPD and consists in the injection of a combination wave ($1.2/50 \mu s$ in open circuit - $8/20 \mu s$ in short circuit).

Protection level - U_p

This is the maximum voltage on the surge protector output when subjected to an impulse current equivalent to its nominal discharge current (I_n). Therefore this parameter characterizes the performance of the SPD in limiting the transient overvoltage across its terminal in order to protect the equipment.

SURGE PROTECTOR TECHNOLOGY

CITEL AC surge protectors are based on zinc metal-oxide varistors (MOV), the best compromise between a fast response time ($<25 ns$) and a high discharge current capacity, which are the main parameters to provide efficient protection.

The rating of MOVs is chosen high enough to avoid failure during surge event. Nevertheless the end of life of these varistors must be absolutely monitored thus requiring the systematic use of built-in thermal disconnection devices.

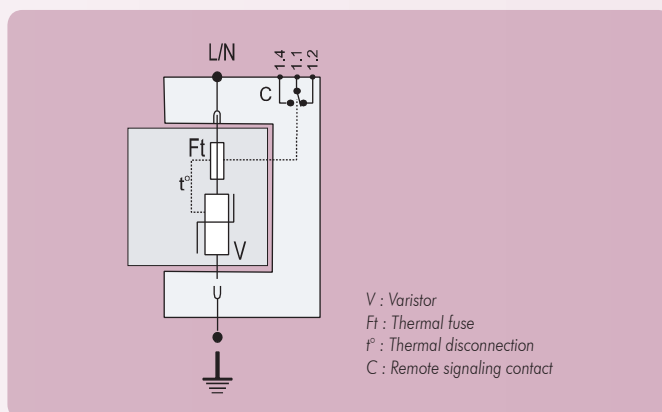

Depending of the needed parameters and the type of AC network to protect, the electrical diagram and the chosen MOVs will be different. MOVs are connected in parallel between Line, Neutral and PE. In some configuration, the protection between Neutral and PE is provided by a dedicated gas tube.

VG TECHNOLOGY BY CITEL

In order to improve the surge protection efficiency, CITEL has developed a patented technology which combines a high energy varistor (MOV) network and specific Gas-filled Spark Gap (GSG): for this reason, the «VG» surge protectors (DS150VG, DS250VG, DUT250VG, DS40VG...) can get higher performance in :

- Protection level,
- Life duration (due to the suppression of leakage current),
- Continuous operation and power quality (no follow current),
- Withstand to temporary overvoltages,
- End of life behavior.



AC Overview

SURGE PROTECTION INSTALLATION

Location

Surge protectors are installed as follows, according to their types :

- Type 1 or «Heavy duty» : at the origin of the installation, in a separate box or on the main electrical panel, for efficient discharge of high lightning currents.
- Type 2 or «Primary» : at the origin of the installation, on the main electrical panel, so as to shunt lightning currents as directly as possible and thereby avoid coupling.
- Type 2 (or Type 3) or «Secondary» : on the secondary panel, near the sensitive equipment, to limit ringing and improve the level of protection.

Wiring

AC surge protectors are connected in parallel on the AC network and must be equipped, in their branch, with external fuses for short-circuit protection (rating and type in the installation sheets).

The main principles to follow for efficient application:

- The total length of connection wires to AC network must be lower than 0.5 m in order not to increase the protection level (Up) provided by the SPD.
- Wiring is made by screw connections. On some models, a distribution bus can be used.
- The protection wire coming from the SPD must be connected to the bonding bar of the electrical panel. Paralleling the protection wire with phases conductors must be avoided.
- The cross sectional wire must be 4 mm² minimum for Type 2 SPD and 10 mm² for Type 1 SPD.
- Local earthing resistance must be in compliance with the electrical rules.

Further information can be found in IEC 61643-12 standard (selection and application principles for low voltage SPD).

MAINTENANCE

DS surge protectors are designed for repetitive operation and do not require specific maintenance. Nevertheless, in case of an extreme event, a controlled end of life could occur and a maintenance operation must be performed .

Signaling

DS surge protectors are equipped with a failure indicator (mechanical or light) linked to the internal thermal disconnecter: in case of safety disconnection, the indicator will switch on and the SPD must be replaced.

Remote Signaling

Most DS surge protectors are available in «remote signaling» versions. This feature, which allows remote checking of the status of the surge protector, is especially important when the products are hard to reach or unsupervised.

The system consists of an auxiliary changeover contact that is activated if the surge protector module changes status.

This lets the user monitor :

- the good operation of the SPD
- the presence of the plug-in modules (if any)
- the end of life (disconnection) of the surge protector.

The remote signaling version allows the choice of signaling system appropriate to the installation (light, buzzer, automation, modem transmission...).

Pluggable design

The design of most CITELE AC surge protectors is based on the use of a pluggable module to be inserted into a matching receptacle. This makes replacement, and checking very easy without impairing the protection function. On multipolar surge protectors, the possibility of replacing a single pole makes rehabilitating a surge protector less expensive.

The plug-in module is identified with a color label in relation with the type (Black = Type 1 ; Red = Type 2 ; Blue = Type 2 low power or Type 3) and are keyed for operating voltage, in order to avoid misapplications.

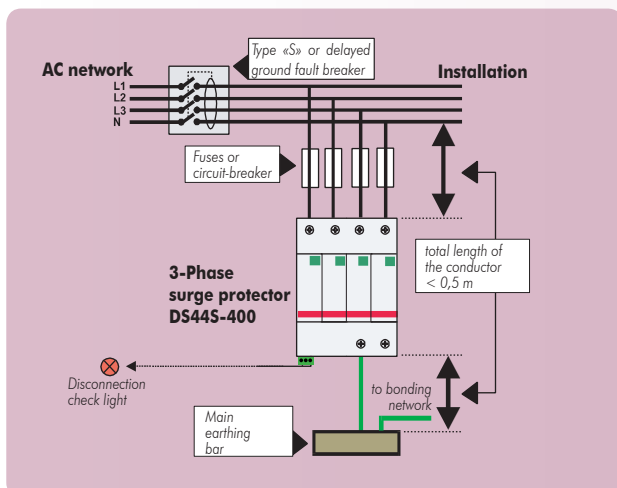

TYPE 1 + 2 + 3 AC POWER SURGE PROTECTOR

**limp
25kA**

DS250VG



- Type 1+2+3 Surge Protector
- limp: 25 kA
- I_{max}: 70 kA
- Low residual voltage
- Remote signaling

DS25x VG-xxx/G

- « » = CT1 configuration (common mode)
- «G» = CT2 configuration (common and differential mode)
- Operating voltage
- «VG» = VG Technology
- Number of protected poles (1,2,3,4)

Dimensions and Diagram

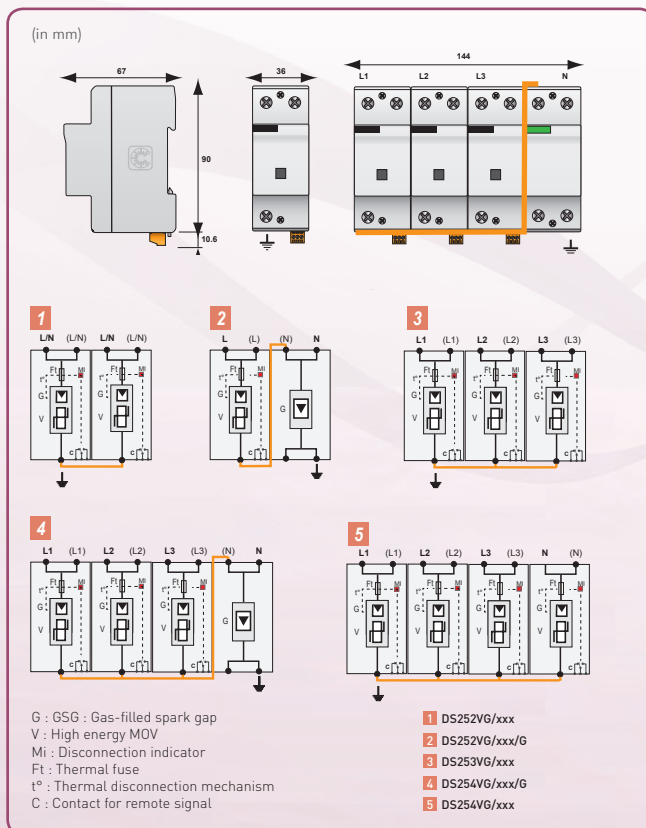

Characteristics

CITEL PART NUMBER	DS25xVG-120	DS25xVG-300
AC Network	120/208V	230/400V
Connection mode	L/N, L/PE	L/N, L/PE
AC system	TT, TN	TT, TN
Max operating voltage	U _c 150 Vac	255 Vac
TOV withstand	U _T 175 Vac	450 Vac
Operating current	I _c none	none
Leakage current at U _c	I _f none	none
Follow current	I _n 30 kA	30 kA
Nominal discharge current 15 x 8/20 μs impulses	I _{max} 70 kA	70 kA
Maximal discharge current max. withstand @ 8/20 μs	limp 25 kA	25 kA
Max. lightning current by pole max. withstand @ 10/350 μs	U _{res} 0,5 kV	0,8 kV
Residual voltage (@ limp)	U _p 1 kV	1,5 kV
Protection Level (@ I _n)	25000 A	25000 A
Admissible short-circuit current	internal	Fuse type gG - 125 A max. (see Note 1)
Thermal disconnector	see diagram	Type «S» or delayed
Fuses	by screw terminal: 6-35 mm ² / by bus	1 mechanical indicator
Installation ground fault breaker	output on changeover contact	on symmetrical rail 35 mm
Dimensions	-40/+85°C	IP 20
Connection	thermoplastic PEI UL94-5VA	
Disconnection indicator	IEC 61643-1 International Low voltage SPD -Class I, II & III Tests	
Remote signaling of disconnection	EN 61643-11 Europe Low voltage SPD -Class I, II & III Tests	
Mounting	UL1449 3rd Edition USA, Canada Type 4, Type 2 Location	
Operative temperature	CSA C22.2 No. 8-M1986 Class 9091 32, Class 9091 92	
Protection class		
Housing material		

Note 1: Rating in compliance with nominal discharge current. In order to increase service continuity, higher rating can be used. For further information, please consult product instructions.

TYPE 1 + 2 AC POWER SURGE PROTECTOR

DS150E

**limp
15kA**



- Type 1+2 AC Surge Protector
- limp: 15 kA
- I_{max}: 140 kA
- Remote signaling

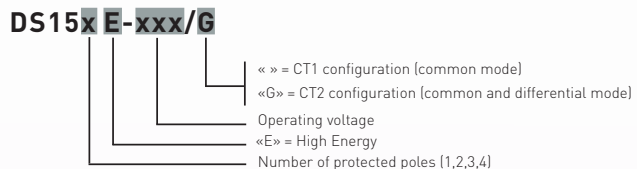

Dimensions and Diagram

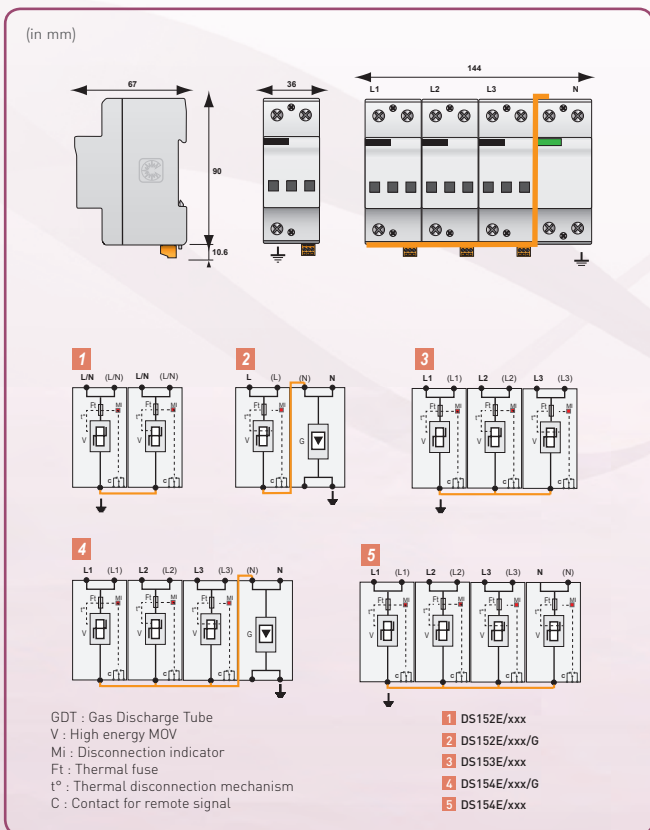

Characteristics

CITEL PART NUMBER*	DS150E-120	DS150E-300	DS150E-400
AC Network	120/208V	230/400 V	230/400V
Connection mode	L/PE	L/N	L/N, L/PE
AC system	TT, TN	TT, TN	IT, TT, TN
Max operating voltage	U _c 150 Vac	300 Vac	400 Vac
TOV withstand	U _T 175 Vac	335 Vac	400 Vac
Operating current	I _c < 2 mA	< 2 mA	< 2 mA
Leakage current at U _c			
Follow current	I _f none	none	none
Nominal discharge current	I _n 70 kA	70 kA	60 kA
15 x 8/20 μs impulses			
Maximal discharge current	140 kA	140 kA	140 kA
max. withstand @ 8/20 μs			
Max. lightning current by pole	limp 15 kA	15 kA	15 kA
max. withstand @ 10/350 μs			
Residual voltage (@ limp)	0,5 kV	0,9 kV	1,5 kV
Protection Level (@I _n)	Up 1 kV	2 kV	2,5 kV
Admissible short-circuit current	25000 A	25000 A	25000 A
Thermal disconnector	internal		
Fuses	Fuse type gG - 125 A max. (see Note 1)		
Installation ground fault breaker	Type «S» or delayed		
Dimensions	see diagram		
Connection	by screw terminal: 6-35 mm ² / by bus		
Disconnection indicator	3 mechanical indicators		
Remote signaling of disconnection	output on changeover contact		
Mounting	on symmetrical rail 35 mm		
Operative temperature	-40/+85°C		
Protection class	IP 20		
Housing material	thermoplastic PEI UL94-5VA		
IEC 61643-1	International	Low voltage SPD - Class I & II Tests	
EN 61643-11	Europe	Low voltage SPD - Class I & II Tests	
UL1449 3rd Edition	USA, Canada	Type 4, Type 2 Location	
CSA C22.2 No. 8-M1986		Class 9091 32, Class 9091 92	

Note 1: Rating in compliance with nominal discharge current. In order to increase service continuity, higher rating can be used. For further information, please consult product instructions.

* Other tension available U_c : 480V

TYPE 1 + 2 PLUGGABLE AC POWER SURGE PROTECTOR

DS130

**limp
12.5kA**

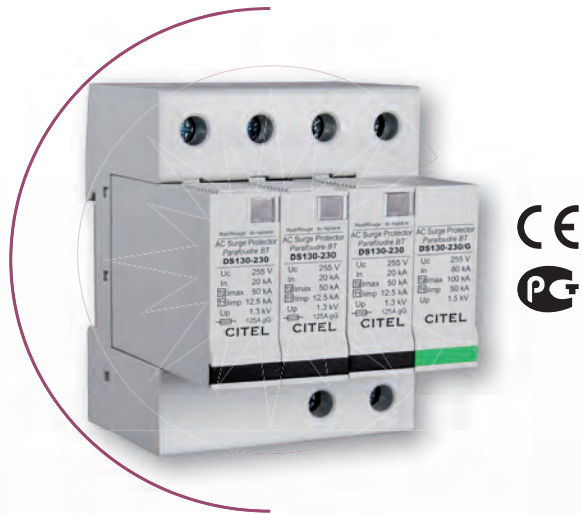

- Type 1 + 2 AC Surge Protector
- In: 20kA
- limp: 12.5kA
- Pluggable module for each phase
- Remote signaling (option)

DS13x S-xxx/G

- « » = CT1 configuration (common mode)
- «G» = CT2 configuration (common and differential mode)
- Operating voltage
- «S» = Remote Signal option
- Number of protected poles (1,2,3,4)

Dimensions and Diagram

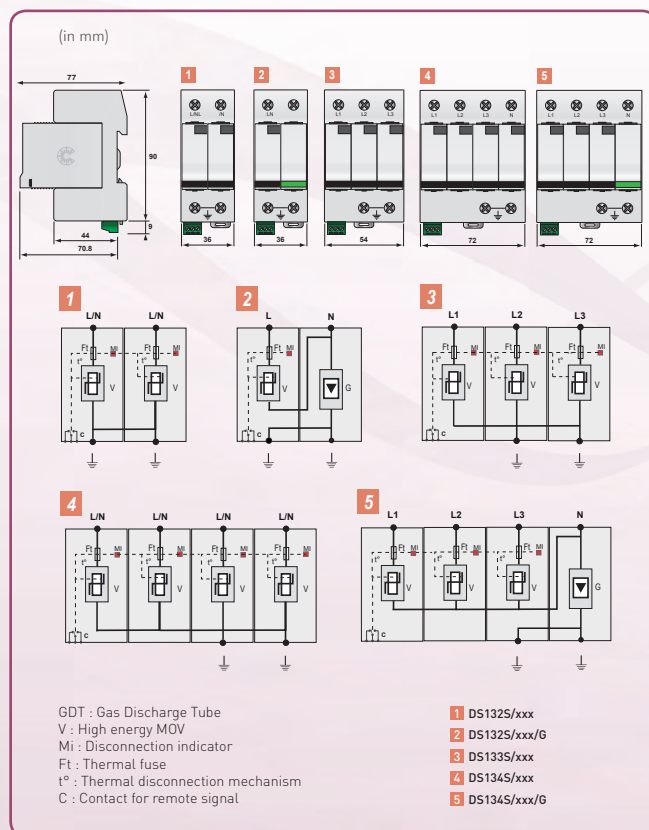

Characteristics

CITEL PART NUMBER	DS131-120	DS131-230	DS131-400
AC Network	120/208V	230/400 V	230/400V
Max operating voltage	Uc 150 Vac	255 Vac	400 Vac
TOV withstand	U _T 175 Vac	335 Vac	400 Vac
Operating current	Ic < 1 mA	< 1 mA	< 1 mA
Leakage current at Uc			
Follow current	If none	none	none
Nominal discharge current	In 20 kA	20 kA	20 kA
15 x 8/20 μs impulses			
Max. lightning current by pole	limp 12.5 kA	12.5 kA	12.5 kA
max. withstand @ 10/350 μs			
Protection Level (@ In)	Up 0.9 kV	1.3 kV	1.7 kV
Admissible short-circuit current	25000 A	25000 A	25000 A
Thermal disconnecter	internal		
Fuses	Fuse type gG - 125 A max.		
Installation ground fault breaker	Type «S» or delayed		
Dimensions	see diagram		
Connection	by screw terminal: 4-25 mm ²		
Disconnection indicator	1 mechanical indicator		
Remote signaling of disconnection	Option DS131S - output on changeover contact		
Mounting	on symmetrical rail 35 mm		
Operative temperature	-40/+85°C		
Protection class	IP 20		
Housing material	thermoplastic UL94-V0		
IEC 61643-1	International	Low voltage SPD - Class I & II Tests	
EN 61643-11	Europe	Low voltage SPD - Class I & II Tests	

Note 1: Rating in compliance with nominal discharge current. In order to increase service continuity, higher rating can be used. For further information, please consult product instructions.

TYPE 2 AC POWER SURGE PROTECTOR

DS70R

**Imax
70kA**

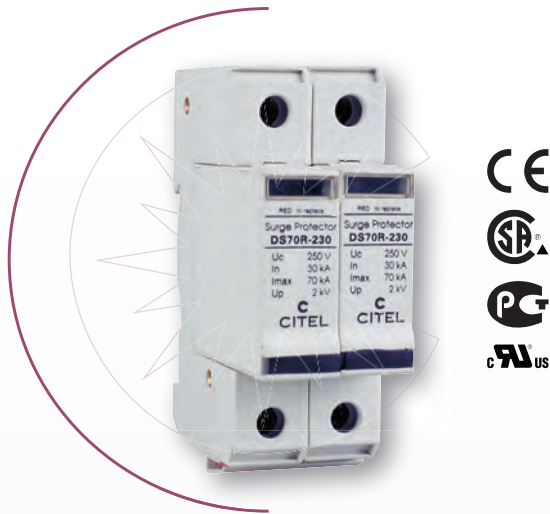

- Re-inforced Type 2 Surge Protector
- In: 30kA
- I_{max}: 70kA
- Pluggable module for each phase
- Remote signaling (option)

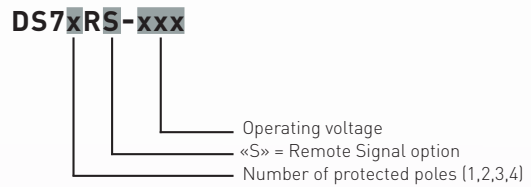

Dimensions and Diagram

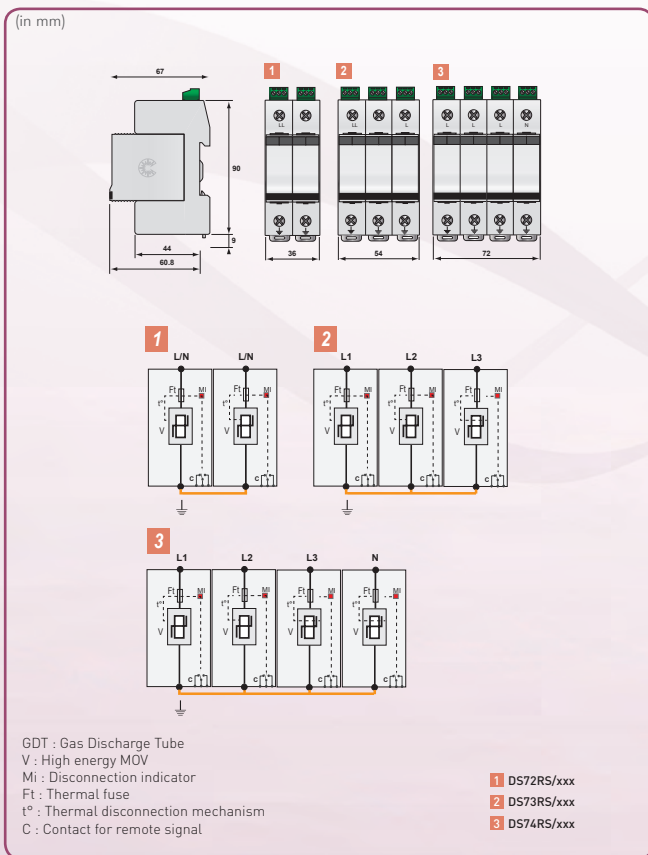

Characteristics

CITEL PART NUMBER	DS71R-120	DS71R-230	DS71R-400
AC Network	120/208V	230/400 V	230/400V
Max operating voltage	U _c 150 Vac	255 Vac	400 Vac
TOV withstand	U _T 175 Vac	335 Vac	400 Vac
Operating current	I _c < 1 mA	< 1 mA	< 1 mA
Leakage current at U _c			
Follow current	I _f none	none	none
Nominal discharge current 15 x 8/20 μs impulses	I _n 30 kA	30 kA	30 kA
Maximal discharge current max. withstand @ 8/20 μs	I _{max} 70 kA	70 kA	70 kA
Protection Level (@ I _n)	U _p 1 kV	1.4 kV	1.8 kV
Residual voltage @ 10 kA	0.7 kV	1 kV	1.4 kV
Residual voltage @ 5 kA	0.6 kV	0.9 kV	1.2 kV
Admissible short-circuit current	25000 A	25000 A	25000 A
Thermal disconnector	internal		
Fuses	Fuse type gG - 100 A max. (see Note 1)		
Installation ground fault breaker	Type «S» or delayed		
Dimensions	see diagram		
Connection	by screw terminal: 4-25 mm ² / by bus		
Disconnection indicator	2 mechanical indicators by pole		
Remote signaling of disconnection	Option DS70RS - output on changeover contact		
Mounting	on symmetrical rail 35 mm		
Operative temperature	-40/+85°C		
Protection class	IP 20		
Housing material	thermoplastic UL94-V0		
IEC 61643-1	International	Low voltage SPD - Class II Test	
EN 61643-11	Europe	Low voltage SPD - Class II Test	
UL1449 3rd Edition	USA, Canada	Type 4, Type 2 Location	
CSA C22.2 No. 8-M1986		Class 9091 32, Class 9091 92	

Note 1: Rating in compliance with nominal discharge current. In order to increase service continuity, higher rating can be used. For further information, please consult product instructions.

TYPE 2 AC POWER SURGE PROTECTOR

DS40

**I_{max}
40kA**

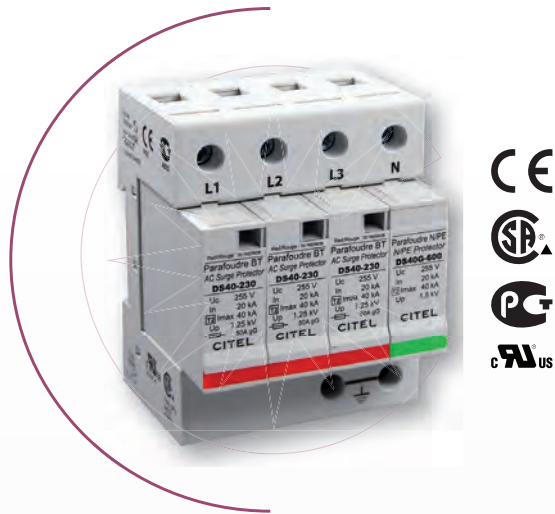

- Type II AC Surge Protector
- I_n: 20kA
- I_{max}: 40kA
- Pluggable module for each phase
- Remote signaling (option)

DS4x S-xx/G

- «x» = CT1 configuration (common mode)
- «G» = CT2 configuration (common and differential mode)
- Operating voltage
- «S» = Remote Signal option
- Number of protected poles (1,2,3,4)

Dimensions and Diagram

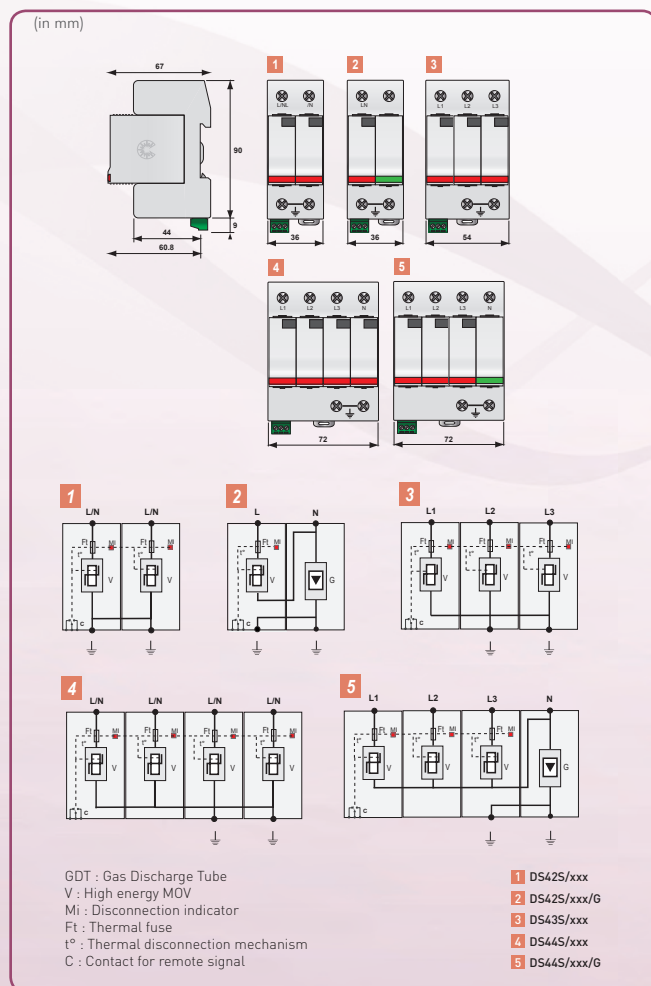

Characteristics

CITEL PART NUMBER*	DS41-120	DS41-230	DS41-400
AC Network	120/208V	230/400 V	230/400V
Max operating voltage	U _c 150 Vac	255 Vac	400 Vac
TOV withstand	U _T 175 Vac	355 Vac	400 Vac
Operating current	I _c < 1 mA	< 1 mA	< 1 mA
Leakage current at U _c	I _f none	none	none
Nominal discharge current 15 x 8/20 μs impulses	I _n 20 kA	20 kA	20 kA
Maximal discharge current max. withstand @ 8/20 μs	I _{max} 40 kA	40 kA	40 kA
Protection Level (@ I _n)	U _p 0.9 kV	1.25 kV	1.8 kV
Residual voltage @ 10 kA	0.7 kV	1.1 kV	1.5 kV
Residual voltage @ 5 kA	0.6 kV	0.9 kV	1.3 kV
Admissible short-circuit current	25000 A	25000 A	25000 A
Thermal disconnecter	internal		
Fuses	Fuse type gG - 50A max. (see Note 1)		
Installation ground fault breaker	Type «S» or delayed		
Dimensions	see diagram		
Connection	by screw terminal: 4-25 mm ² / by bus		
Disconnection indicator	1 mechanical indicator		
Remote signaling of disconnection	Option DS40S - output on changeover contact		
Mounting	on symmetrical rail 35 mm		
Operative temperature	-40/+85°C		
Protection class	IP 20		
Housing material	thermoplastic UL94-V0		
IEC 61643-1	International	Low voltage SPD - Class II Test	
EN 61643-11	Europe	Low voltage SPD - Class II Test	
UL1449 3rd Edition	USA, Canada	Type 4, Type 2 Location	
CSA C22.2 No. 8-M1986		Class 9091 32, Class 9091 92	

Note 1: Rating in compliance with nominal discharge current. In order to increase service continuity, higher rating can be used. For further information, please consult product instructions.

*other tensions available : 60Vac, 280, 320, 480, 600 and 690V

TYPE 2 AC POWER SINGLE-PHASE SURGE PROTECTOR

I_{max}
15-40kA

DS215
DS240



- Compact single phase Type 2 Surge Protector
- In: 5 or 20kA
- I_{max}: 15 or 40kA
- Pluggable module
- Remote signaling (option)

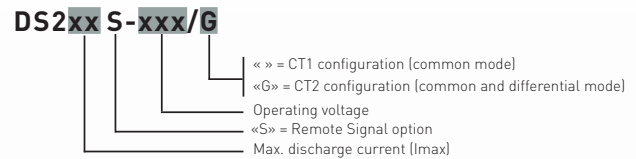

Dimensions and Diagram

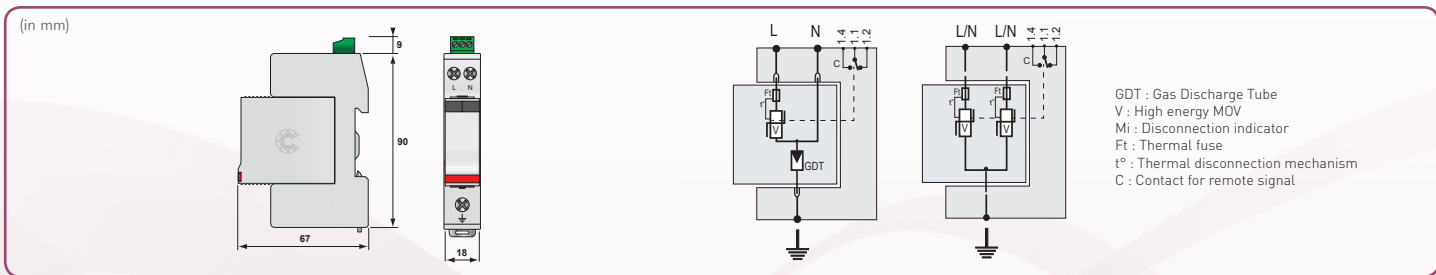

Characteristics

CITEL PART NUMBER	DS240-120	DS240-120/G	DS240-230/G	DS240-400	DS215-120	DS215-120/G	DS215-230/G	DS215-400
AC Network	120V	120V	230V	230V	120V	120V	230V	230V
AC System	TT-TN	TT-TN	TT-TN	TT-TN-IT	TT-TN	TT-TN	TT-TN	TT-TN-IT
Max operating voltage	U _c 150 Vac	150 Vac	255 Vac	400 Vac	150 Vac	150 Vac	255 Vac	400 Vac
TOV withstand	U _T 175 Vac	175 Vac	335 Vac	400 Vac	175 Vac	175 Vac	335 Vac	400 Vac
Operating current	I _c < 1 mA	< 1 mA	< 1 mA	< 1 mA	< 1 mA	<< 1 mA	<< 1 mA	< 1 mA
Leakage current at U _c								
Protection mode(s)	MC**	MC/MD**	MC/MD**	MC**	MC**	MC/MD**	MC/MD**	MC**
Nominal discharge current 15 x 8/20 μs impulses	I _n 20 kA	20 kA	20 kA	20 kA	5 kA	5 kA	5 kA	5 kA
Max. discharge current max. withstand @ 8/20 μs	I _{max} 40 kA	40 kA	40 kA	40 kA	15 kA	15 kA	15 kA	15 kA
Protection Level (@ I _n)	U _p 0.9 kV	1.5/0.9 kV**	1.5/1.25 kV**	1.8 kV	0.6 kV	1.5/0.6 kV**	1.5/0.9 kV**	1.3 kV
Residual voltage @ 5 kA	0.6 kV	0.6 kV	0.9 kV	1.3 kV	0.6 kV	0.6 kV	0.9 kV	1.3 kV
Admissible short-circuit current	10000 A	10000 A	10000 A	10000 A	10000 A	10000 A	10000 A	10000 A
Thermal disconnecter	internal				internal			
Fuses	Fuse type gG - 50A max. *				Fuse type gG - 20A max. *			
Installation ground fault breaker	Type «S» or delayed				Type «S» or delayed			
Dimensions	see diagrams				see diagram			
Connection	by screw terminal: 1.5-10 mm ² (L/N) or 2.5-25 mm ² (PE)				by screw terminal: 1.5-10 mm ² (L/N) or 2.5-25 mm ² (PE)			
Disconnection indicator	2 (or 1) mechanical indicators				2 (or 1) mechanical indicators			
Remote signaling of disconnection	Option DS240S - output on changeover contact				Option DS215S - output on changeover contact			
Mounting	on symmetrical rail 35 mm				on symmetrical rail 35 mm			
Operative temperature	-40/+85°C				-40/+85°C			
Protection class	IP 20				IP 20			
Housing material	thermoplastic UL94-V0				thermoplastic UL94-V0			
IEC 61643-1	International	Low voltage SPD - Test Class II			Low voltage SPD - Test Class II			
EN 61643-11	Europe	Low voltage SPD - Test Class II			Low voltage SPD - Test Class II			
UL1449 3rd Edition	USA, Canada	Type 4, Type 2 Location			Type 4, Type 2 Location			
CSA C22.2 No. 8-M1986		Class 9091 32, Class 9091 92			Class 9091 32, Class 9091 92			

* : Rating in compliance with nominal discharge current. In order to increase service continuity, higher rating can be used. For further information, please consult product instructions.
** : MC= Common mode (L/PE or N/PE) / MD= Differential mode (L/N)

TYPE 2 AC POWER 3-PHASE SURGE PROTECTOR

I_{max}
15-40kA

DS415
DS440



- Compact 3-phase Type 2 Surge Protector
- In: 5 or 20kA
- I_{max}: 15 or 40kA
- Pluggable module
- Remote signaling (option)

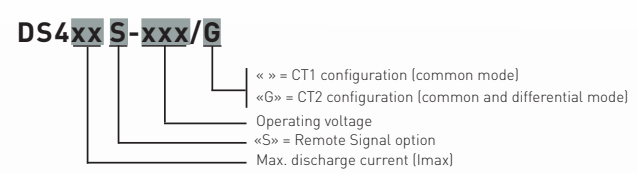

Dimensions and Diagram

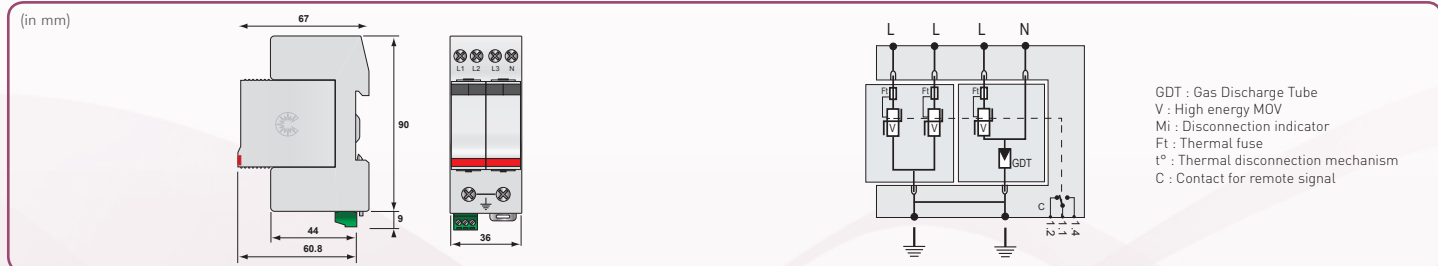

Characteristics

CITEL PART NUMBER	DS440-120	DS440-120/G	DS440-230/G	DS440-400	DS415-120	DS415-120/G	DS415-230/G	DS415-400
AC Network	120/208V	120/208V	230/400V	230/400V	120/208V	120/208V	230/400V	230/400V
AC System	TT-TN	TT-TN	TT-TN	TT-TN	TT-TN	TT-TN (DS415)	TT-TN	TT-TN-IT
Max operating voltage	U _c 150 Vac	150 Vac	255 Vac	400 Vac	150 Vac	150 Vac	255 Vac	400 Vac
TOV withstand	U _T 175 Vac	175 Vac	335 Vac	400 Vac	175 Vac	175 Vac	335 Vac	400 Vac
Operating current Leakage current at U _c	I _c < 1 mA	< 1 mA	< 1 mA	< 1 mA	< 1 mA	<< 1 mA	<< 1 mA	< 1 mA
Protection mode(s)	MC**	MC/MD**	MC/MD**	MC**	MC**	MC/MD**	MC/MD**	MC**
Nominal discharge current 15 x 8/20 μs impulses	I _n 20 kA	20 kA	20 kA	20 kA	5 kA	5 kA	5 kA	5 kA
Max. discharge current max. withstand @ 8/20 μs	I _{max} 40 kA	40 kA	40 kA	40 kA	15 kA	15 kA	15 kA	15 kA
Protection Level (@ I _n)	U _p 0.9 kV	1.5/0.9 kV**	1.5/1.25 kV**	1.8 kV	0.6 kV	1.5/0.6 kV**	1.5/0.9 kV**	1.3 kV
Residual voltage @ 5 kA	0.6 kV	0.6 kV	0.9 kV	1.3 kV	0.6 kV	0.6 kV	0.9 kV	1.3 kV
Admissible short-circuit current	10000 A	10000 A	10000 A	10000 A	10000 A	10000 A	10000 A	10000 A
Thermal disconnecter	Internal				Internal			
Fuses	Fuse Type gG - 50A max. *				Fuse type gG - 20A max. *			
Installation ground fault breaker	Type "S" or delayed				Type "S" or delayed			
Dimensions	see diagrams				see diagram			
Connection	by screw terminal: 1.5-10 mm ² (L/N) or 2.5-25 mm ² (PE)				by screw terminal: 1.5-10 mm ² (L/N) or 2.5-25 mm ² (PE)			
Disconnection indicator	4 (or 3) mechanical indicators				4 (or 3) mechanical indicators			
Remote signaling of disconnection	Option DS440S - output on changeover contact on symmetrical rail 35 mm				Option DS415S - output on changeover contact on symmetrical rail 35 mm			
Mounting	IP 20				IP 20			
Operative temperature	-40/+85°C				-40/+85°C			
Protection class	thermoplastic UL94-V0				thermoplastic UL94-V0			
Housing material	thermoplastic UL94-V0				thermoplastic UL94-V0			
IEC 61643-1	International	Low voltage SPD - Test Class II			Low voltage SPD - Test Class II			
EN 61643-11	Europe	Low voltage SPD - Test Class II			Low voltage SPD - Test Class II			
UL1449 3rd Edition	USA, Canada	Type 4, Type 2 Location			Type 4, Type 2 Location			
CSA C22.2 No. 8-M1986		Class 9091 32, Class 9091 92			Class 9091 32, Class 9091 92			

*: Rating in compliance with nominal discharge current. In order to increase service continuity, higher rating can be used. For further information, please consult product instructions.
**: MC= Common mode (L/PE or N/PE) / MD= Differential mode (L/N)

DC POWER SURGE PROTECTOR

DS220DC / DS230DC / DS240DC

**Imax
20-40kA**

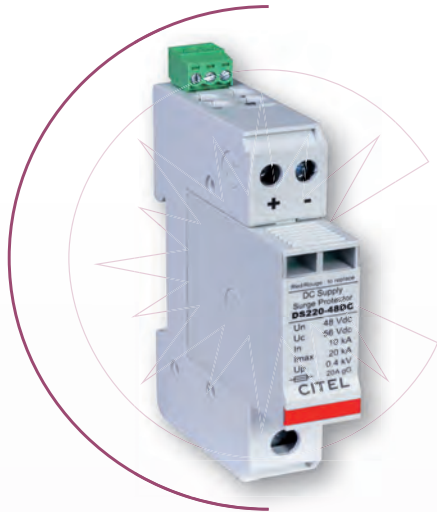

- Compact Type 2 SPD for DC Power Supply
- From 12 to 350 Vdc
- Low Up protection level
- I_{max}: 20 to 40 kA
- Pluggable module
- Remote signaling (option)

DS2x0 S-xxxDC

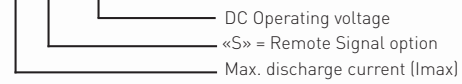

Dimensions and Diagram

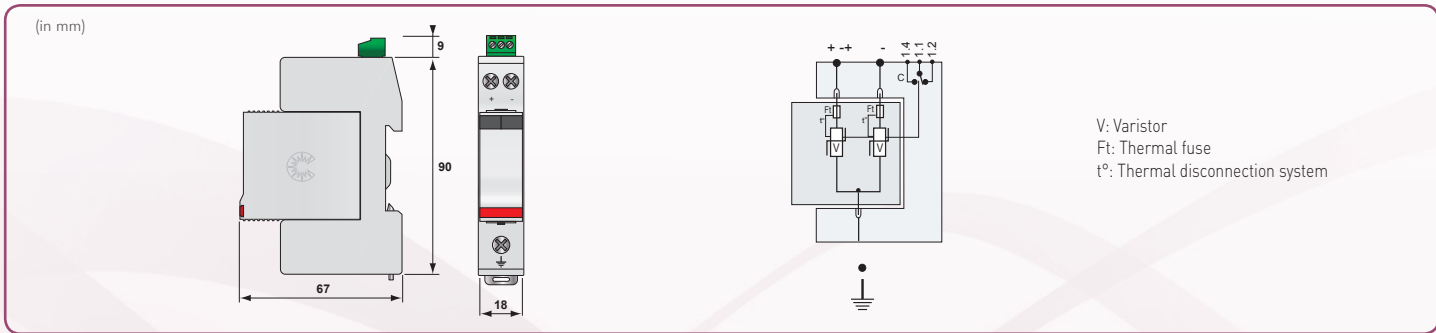

Characteristics

CITEL PART NUMBER	DS220-12DC	DS220-24DC	DS230-48DC	DS240-75DC	DS240-95DC	DS240-110DC	DS240-130DC	DS240-220DC	DS240-280DC	DS240-350DC
Nominal DC voltage	Un 12 Vdc	24 Vdc	48 Vdc	75 Vdc	95 Vdc	110 Vdc	130 Vdc	220 Vdc	280 Vdc	350 Vdc
Maximum operating voltage	Uc 24 Vdc	38 Vdc	65 Vdc	100 Vdc	125 Vdc	150 Vdc	180 Vdc	275 Vdc	350 Vdc	460 Vdc
Nominal discharge current	In 10 kA	10 kA	15 kA	20 kA	20 kA	20 kA	20 kA	20 kA	20 kA	20 kA
Maximal discharge current	I _{max} 20 kA	20 kA	30 kA	40 kA	40 kA	40 kA	40 kA	40 kA	40 kA	40 kA
Protection Level (@ In)	Up 250 V	250 V	300 V	390 V	450 V	500 V	620 V	900 V	1200 V	1400 V
Residual voltage @ 3kA	195 V	195 V	230 V	280 V	310 V	370 V	510 V			
Thermal disconnecter	internal	internal	internal	internal	internal	internal	internal	internal	internal	internal
Protective fuses (if necessary)	20A gG	20A gG	20A gG	50A gG	50A gG	50A gG	50A gG	50A gG	50A gG	50A gG
Dimensions	see drawing									
Wiring to network	by screw terminal - cross section 1,5-10mm ² (active wire) and 2,5-25mm ² (earthing wire)									
Disconnection indicator	2 mechanical indicators									
Replacement module	pluggable module DSM2x0-xxDC									
Remote signaling	option (DS2x0S-xxxDC) - by changeover contact									
Mounting	on symmetrical rail									
Operative temperature	-40/+85°C									
Protection index	IP 20									
Housing material	thermoplastic UL94-V0									
IEC 61643-1	International	Low voltage SPD - Test Class II								
IEC 61643-11	Europe	Low voltage SPD - Test Class II								
UL1449 3rd Edition	USA, Canada	Type 4, Type 2 Location								
CSA C22.2 No. 8-M1986		Class 9091 32, Class 9091 92								

DC POWER SURGE PROTECTOR

DS210DC

**I_{max}
2-6kA**



- Compact Type 3 SPD for DC Power Supply
- Common & differential modes
- From 12 to 130 Vdc
- I_{max}: 2 to 6 kA
- Disconnection & voltage indicator
- Pluggable module

DS210-xxxDC

DC Operating voltage

Dimensions and Diagram

(in mm)

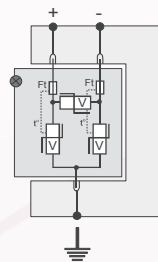
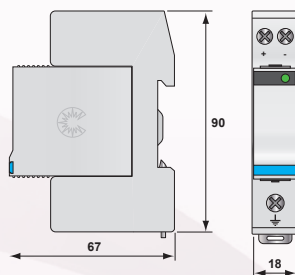

V: Varistor
Ft: Thermal fuse
t°: Thermal disconnection system

Characteristics

CITEL PART NUMBER		DS210-12DC	DS210-24DC	DS210-48DC	DS210-75DC	DS210-95DC	DS210-110DC	DS210-130DC
Nominal DC voltage	Un (dc)	12 Vdc	24 Vdc	48 Vdc	75 Vdc	95 Vdc	110 Vdc	130 Vdc
Maximum AC voltage	Uc	10 Vac	15 Vac	40 Vac	60 Vac	75 Vac	95 Vac	115 Vac
Maximum DC voltage	Uc (dc)	15 Vdc	30 Vdc	56 Vdc	85 Vdc	100 Vdc	125 Vdc	150 Vdc
Nominal discharge current 15 x 8/20 μs impulses	In	1 kA	1 kA	1 kA	2 kA	2 kA	2 kA	2 kA
Maximal discharge current Max withstand 8/20 μs	I _{max}	2 kA	2 kA	2 kA	6 kA	6 kA	6 kA	6 kA
Protection Level (@ In)	Up	85 V	105 V	180 V	250 V	300 V	350 V	400 V
Thermal disconnecter		internal						
Protective fuses (if necessary)		Fuses type gG - 10A						
Dimensions		see drawing						
Wiring to network		by screw terminal - cross section 1,5-10mm ² (active wires) and 2,5-25mm ² (ground)						
Disconnection indicator		green led off						
Replacement module		pluggable module DSM2x0-xxDC						
Mounting		on symmetrical rail 35 mm						
Operative temperature		-40/+85°C						
Protection index		IP 20						
Housing material		thermoplastic UL94-V0						
IEC 61643-1	International	Low voltage SPD - Test Class II						
IEC 61643-11	Europe	Low voltage SPD - Test Class II						
UL1449 3rd Edition	USA, Canada	Type 4, Type 2 Location						
CSA C22.2 No. 8-M1986		Class 9091 32, Class 9091 92						

TYPE 2 + 3 SINGLE-PHASE SURGE PROTECTOR AND RFI FILTER

**Imax
10kA**

DS-HF



- Surge Protector with RFI filtering
- Maximum line current I_L : 16A
- Common and differential mode protection
- Low protection level
- Operating / disconnection indicators
- Imax : 10 kA

Dimensions and Diagram

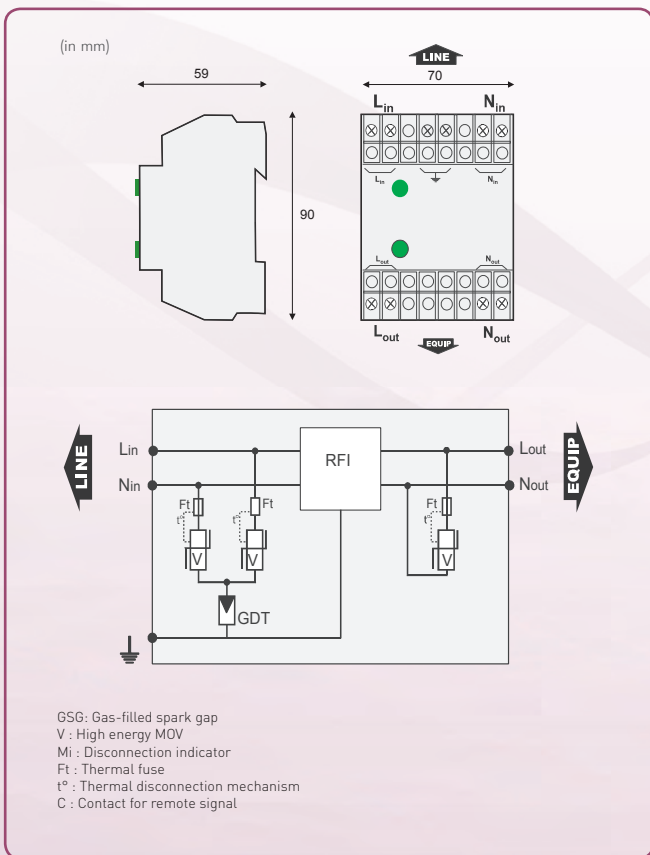

Characteristics

CITEL PART NUMBER	DS-HF	DS-HF-120
AC Network	230 V	230/400V
AC system	TN-TT-IT	TN-TT
Max operating voltage	U _c 255 Vac	150 Vac
TOV withstand	U _T 400 Vac	150 Vac
Operating current	I _c < 1mA	< 1mA
Leakage current at U _c		
Max. line current	I _L 16 A	16 A
Nominal discharge current 15 x 8/20 μs impulses	I _n 3 kA	3 kA
Maximal discharge current max. withstand @ 8/20 μs	I _{max} 10 kA	10 kA
Protection Level (CM/DM)	U _p 1 kV/0.8 kV	0.6 kV/0.5 kV
Combination waveform test class III test	U _{oc} 6 kV	6 kV
RFI filtering	0.1 - 30 Mhz	0.1 - 30 Mhz
Admissible short-circuit current	10000 A	10000 A
Thermal disconnecter	internal	
Fuses	Fuse type gG - 20 A max. (see Note 1)	
Installation ground fault breaker	Type «S» or delayed	
Dimensions	see diagram	
Connection	by screw terminal: 0,75-4 mm ²	
Voltage/operating indicator	green led(s) on	
Disconnection indicator	green led off	
Remote signaling of disconnection	none	
Mounting	on symmetrical rail 35 mm	
Operative temperature	-40/+85°C	
Protection class	IP 20	
Housing material	thermoplastic PEI UL94-5VA	
IEC 61643-1	International	Low voltage SPD - Type I, II & III
EN 61643-11	Europe	Low voltage SPD - Type I, II & III
UL1449 3rd Edition	USA, Canada	Type 4, Type 2 Location
CSA C22.2 No. 8-M1986		Class 9091 32, Class 9091 92

Note 1: Rating in compliance with nominal discharge current. In order to increase service continuity, higher rating can be used. For further information, please consult product instructions.

AC POWER PANEL SURGE PROTECTOR

M Series



- I_{max} from 80 to 200kA (8/20μs)
- All mode of protection
- 200kA Short-circuit Fault Current Rated
- Multi-redundant protection circuit per phase
- Full On-Board Diagnostics - LED indicators, remote & audible alarms
- EMI/RFI Noise Filtering
- NEMA 4/12 enclosure
- UL 1449 3ed. compliant

Dimensions

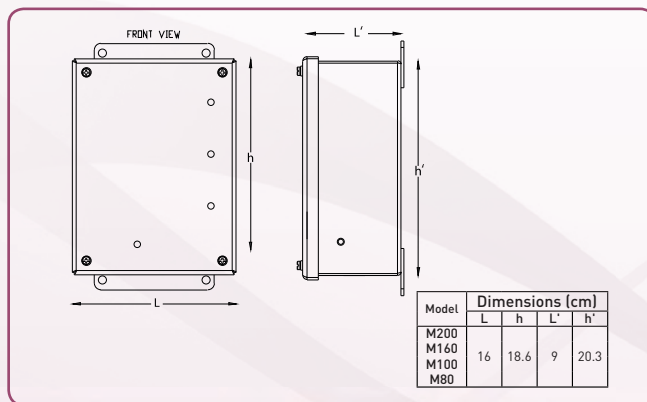

Characteristics

Surge Handling (I _{max}) for :	
M200	200kA/phase
M160	160kA/phase
M100	100kA/phase
M80	80kA/phase
Nominal Discharge Current (I _n)	3 kA & 5 kA
Protection Modes	L-N, L-G, N-G, L-L
LED Indicators	Yes
Audible Alarm	Yes
Remote Signaling	Form C dry contacts
Connecting Wire Size	#10 AWG
Response Time	< 5 nanoseconds
Dimensions	6" x 4" x 3.5"
Enclosure	NEMA 4/12 enclosure
Weight	8 lbs

Configuration

Model	Configuration	UL1449 3kA 8/20μs (VPR)				Energy (10/100us)	MCOV
		L-N	L-G	N-G	L-L		
Mxxx-120T	120/240 Vac, 1 ph, 3 W+G, split phase	800 V	900 V	800 V	1800 V	3,240 J	150V
Mxxx-120Y	120/208 Vac, 3 ph, 4 W+G, wye	800 V	900 V	800 V	1800 V	4,680 J	150V
Mxxx-220Y	220/380 Vac, 3 ph, 4 W+G, wye	1200 V	1200 V	1200 V	2000 V	8,320 J	320V
Mxxx-240Y	240/415 Vac, 3 ph, 4 W+G, wye	1500 V	1200 V	1200 V	2000 V	8,320 J	320V
Mxxx-240DCT	120/240 Vac, 3 ph, 4 W+G, hi-leg	800 V	900 V	800 V	1800 V	6,080 J	150/320V
Mxxx-240D	240 Vac, 3 ph, 3 W+G, delta	-	1200 V	-	2000 V	7,680 J	320V
Mxxx-277Y	277/480 Vac, 3 ph, 4 W+G, wye	1500 V	1200 V	1200 V	2000 V	8,320 J	320V
Mxxx-347Y	347/600 Vac, 3 ph, 4 W+G, wye	1800 V	1800 V	1800 V	3000 V	12,480 J	550V
Mxxx-480D	480 vac, 3 ph, 3 W+G, delta	-	1200 V	-	2000 V	11,520 J	550V

xxx = 200, 160, 100, 80

HARD-WIRED AC SURGE PROTECTOR

MSB

I_{max}
5-10kA

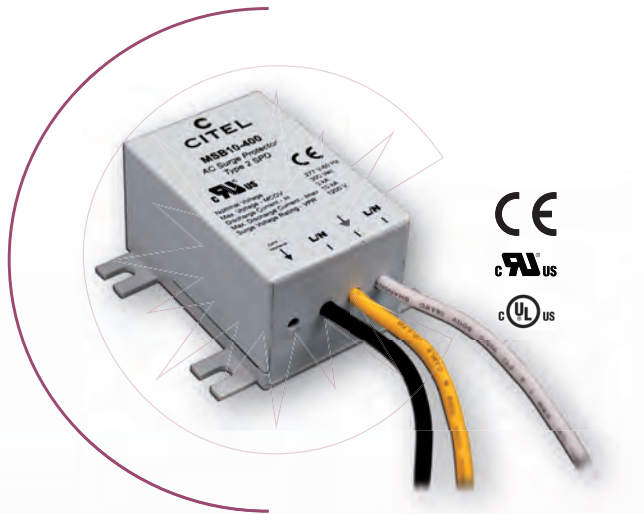

- Compact Type 2 and 3 Surge Protectors
- Wall mounting and hard wired connection
- UL1449 3ed and IP66 (MSB10-400)
- Status indicators
- DC versions available

Dimensions and Diagram

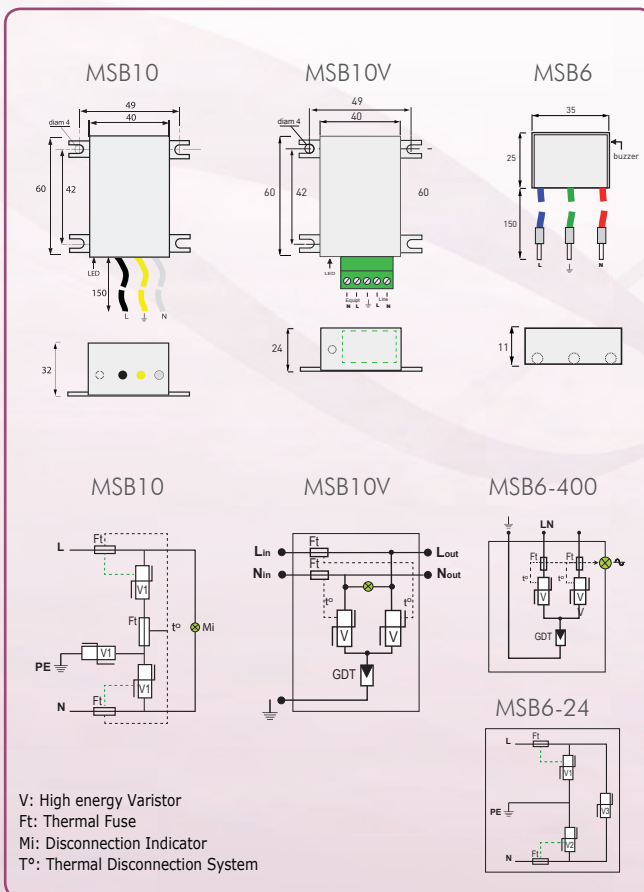

Characteristics

CITEL PART NUMBER	MSB10		MSB10V	MSB6	
	MSB10-400	MSB10-120	MSB10V-400	MSB6-400	MSB6-24
Power supply Network	Un	230 Vac 110-130 Vac	230 Vac	230 Vac	24 Vac
Max operating voltage	Uc	255 Vac 150 Vac	255 Vac	255 Vac	30 Vac
Max. line current	I _L	-	16 A	-	-
Protection Level	Up	1.5 kV 1 kV	1.5 kV	1.5 kV	0.22 kV
Maximal discharge current 1 impulse @ 8/20 μs	I _{max}	10 kA 10 kA	5 kA	5 kA	2 kA
Maximal discharge current 15 impulses @ 8/20 μs	I _n	2.5 kA 2.5 kA	2.5 kA	2.5 kA	0.8 kA
Fail-safe end of life		disconnection disconnection	disconnection	disconnection	-
Disconnection signaling		green light off green light off	green light off	buzzer	-
Wiring		wires wires	screw terminal	wires	wires
Mounting		wall wall	wall	AC outlet	AC outlet

- **MSB10:** Parallel connection to AC line by wires. Wall mounting. UL listed.
- **MSB10V:** In-line connection to AC line through screw terminal. Wall mounting.
- **MSB6:** Ultra compact version to include inside AC outlet. End of life warning by buzzer.



Photovoltaic Overview

SURGE PROTECTION FOR PHOTOVOLTAIC INSTALLATIONS

Photovoltaic plants are often fastidious and cost intensive projects, with a life duration expected for several decades. Many manufacturers of Photovoltaic (PV) modules used to guarantee them a life expectancy greater than 20 years, costs and investment are calculated on this long period. However these systems are often very exposed to lightning phenomena which could drastically reduce the long operating duration required.

Several points must be considered in order to analyze the risk :

1. The larger the field of PV modules, the higher the risk to be disturbed by lightning.
2. Direct effect (strike on the PV modules) and indirect effects (surge voltages on PV modules and on the converters).
3. When the PV system is located in large industrial areas, disturbances by switching surge voltages must be also considered.
4. The risk is in direct relation with the lightning strike density of the area. Some calculations show that the life duration of the PV panels will be lower than 8 years.

EFFICIENT LIGHTNING & SURGE PROTECTION

A professional approach to lightning and surge protection will guarantee your Photovoltaic systems a long life. Some basic but important points must be addressed in order to provide a high level of reliability to your PV system.

Earthing and Bonding

All the metallic frames of the systems must be grounded in order to achieve a global equipotentiality of the installation.

Underground ducts

If possible, the connection line between PV modules and inverter must be underground to limit the direct strike and coupling risks.

AC and DC Surge Protection

Surge Protection of both AC and DC lines must be provided.

In case of direct lightning exposure, the SPDs must be able to partially conduct the lightning currents : Type 1 selection.

On the other hand, the SPD must operate on surge voltages (Type 2).

Do not forget

In order to achieve the best efficiency, surge protection on the other types of conductors such as rotating motor power supply, probes, transmission lines...must be considered.

SURGE PROTECTION FOR PV SYSTEM

SPDs must be first applied to protect the PV inverter, on its AC and DC sides. Extra SPDs must also be used on the AC Distribution Panel and close by the PV modules, especially if these ones are far from the inverter.

The AC side of the installation must be protected by Type 1 or Type 2 AC power SPDs.

Because the DC side of the PV installation is specific by its high DC voltages (up to 1000 Vdc) and its low short-circuit, the SPDs used must be especially designed for this application : CITEC DC surge protectors are in compliance with the relevant test standards as prEN50539-11 (Europe) or UTE C61-740-51 (France). SPDs for DC side are available for Type 1+2 (DS60VGPV) and Type 2 (DS50VGPV and DS50PV) application. Operating voltages up to 1000 Vdc.

The VG versions allows total suppression of operating and leakage current as well as improved life expectancy.

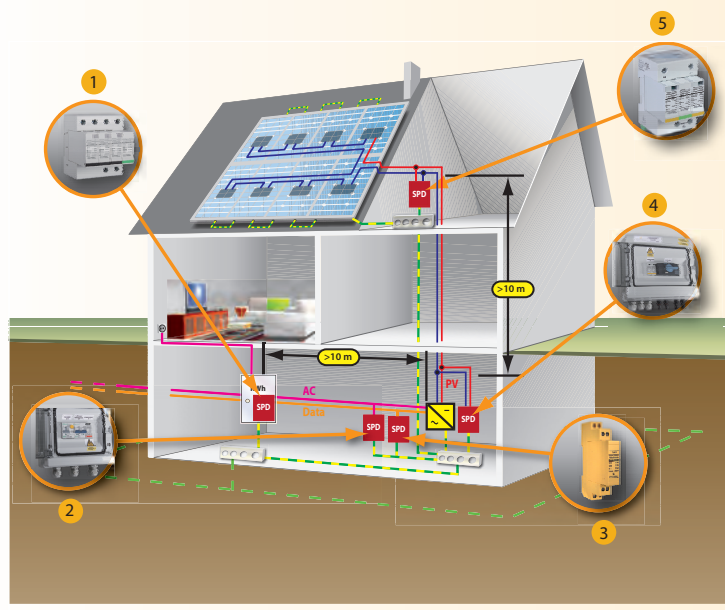

SURGE PROTECTION FOR SOLAR PV SYSTEM

1 AC Distribution Panel

Protects all loads connected to the facility's main distribution panel against transients originating from the AC utility grid or internal switching equipment.

2 Inverter : AC Output

Local protection in front of the inverter to protect against threats from the AC utility and generated internally within the facility.

3 Inverter : Communications Output

Protects inverter, communication equipment and PC workstations against lightning induced transients entering the system via exposed sensor and communication lines.

4 Inverter : DC input

Local protection in front of the inverter to protect against lightning induced transients originating from the solar PV array.

5 Surge protection of PV modules

Protects PV modules, power tracking and blocking diodes from physical damage resulting from lightning induced transients.

TYPE 1 + 2 DC SURGE PROTECTOR FOR PV

limp
12.5kA

DS60VGPV



- Type 1 and 2 Surge protector for Photovoltaic
- VG-Technology
- No leakage, no operating currents
- Improved life expectancy
- limp 12.5 kA/pole @10/350µs
- Common Mode and Differential protection
- Remote Signaling

DS60VGPV-xxx

Network voltage

Dimensions and Diagram

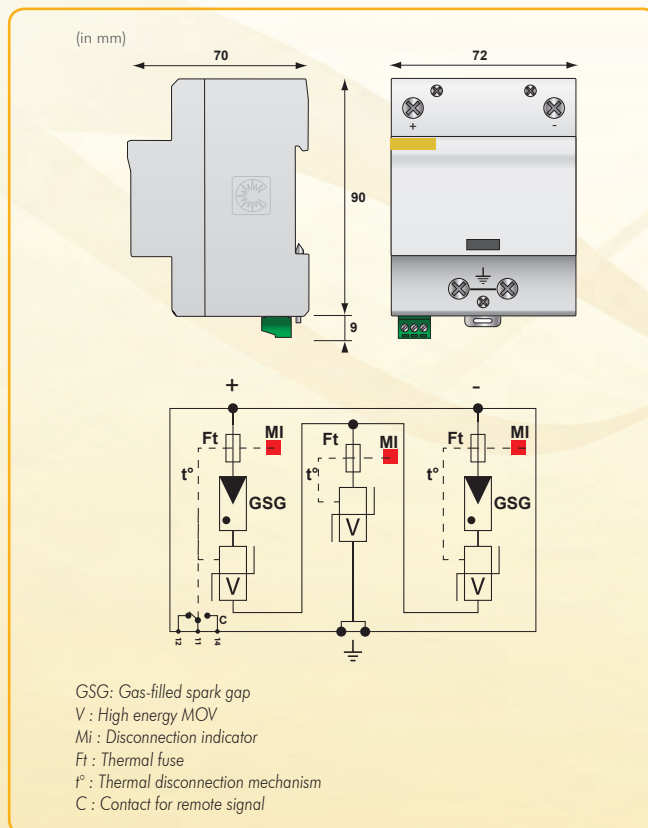

Characteristics

CITEL PART NUMBER	DS60VGPV-500	DS60VGPV-1000
Network voltage	Un dc 500 Vdc	1000 vdc
Protection mode	MC/MD (see Note 1)	MC/MD (see Note 1)
Max operating voltage	Uc dc 600 Vdc	1200 Vdc
IEC/UL nominal discharge current 15 x 8/20 µs impulses	In 20 kA	20 kA
Maximal discharge current max. 10/350 @ 8/20 µs	limp 12.5 kA	12.5 kA
Max. Lightning current by pole max. 8/20 µs	Imax 40 kA	40 kA
Protection Level (@ In)	Up <1.7 kV	<2.8 kV
Residual voltage @ 5 kA	Up <1.4 kV	<2.3 kV
Operating current	Ic	none
Follow current	If	none
Thermal disconnector	internal	
Dimensions	see diagram	
Connection	by screw terminal: 35 mm ² max.	
Disconnection indicator	1 mechanical indicator	
Remote signaling of disconnection	250V/0.5 (AC) - 125V/3A (DC)	
Mounting	on symmetrical rail 35 mm	
Operative temperature	-50/+85°C	
Protection class	IP 20	
Housing material	thermoplastic UL94-V0	
IEC 61643-1	International	Low voltage SPD - Class I and II tests
EN 61643-11	Europe	Low voltage SPD - Class I and II tests
UL1449 3rd Ed. for PV	USA, Canada	Type 4, Type 2 Location
CSA C22.2		Class 90941 32

Note 1: MC = Common Mode (+/PE or -/PE) and MC/MD = Common Mode and Differential Mode (+/-)

TYPE 2 DC SURGE PROTECTOR FOR PV

**Imax
40kA**

DS50VGPV



- Type 2 Surge protector for Photovoltaic
- VG-Technology
- No leakage, no operating currents
- Improved life expectancy
- Impulse currents I_{max}/I_n : 40/20 kA
- Common Mode and Differential protection
- Remote Signaling (option)

DS50VGPVS-xxx

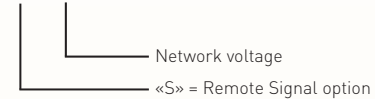

Dimensions and Diagram

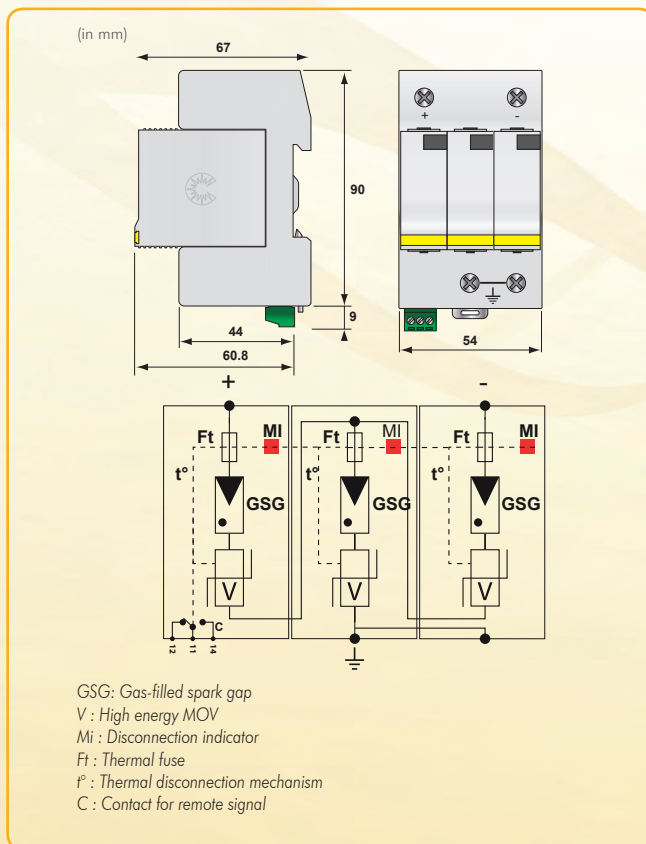

Characteristics

CITEL PART NUMBER	DS50VGPVS-500	DS50VGPVS-1000
Network voltage	Un dc 500 Vdc	1000 vdc
Protection mode	MC/MD (see Note 1)	MC/MD (see Note 1)
Max operating voltage	Uc dc 600 Vdc	1200 Vdc
IEC/UL nominal discharge current 15 x 8/20 μs impulses	In 20 kA	20 kA
Maximal discharge current max. 10/350 @ 8/20 μs	Iimp -	-
Max. Lightning current by pole max. 8/20 μs	I _{max} 40 kA	40 kA
Protection Level (@ I _n)	U _p <2.5 kV	<3.6 kV
Residual voltage @ 5 kA	U _p <1.8 kV	<2.6 kV
Operating current	Ic	none
Follow current	If	none
Thermal disconnector	internal	
Dimensions	see diagram	
Connection	by screw terminal: 25 mm ² max	
Disconnection indicator	1 mechanical indicator	
Remote signaling of disconnection	250V/0.5 (AC) - 125V/3A (DC)	
Mounting	on symmetrical rail 35 mm	
Operative temperature	-50/+85°C	
Protection class	IP 20	
Housing material	thermoplastic UL94-V0	
IEC 61643-1	International	Low voltage SPD - Class II test
EN 61643-11	Europe	Low voltage SPD - Class II test
UL1449 3rd Ed. for PV	USA, Canada	Type 4, Type 2 Location
CSA C22.2		Class 90941 32

Note 1: MC = Common Mode (+/PE or -/PE) and MC/MD = Common Mode and Differential Mode (+/-)

TYPE 2 DC POWER SURGE PROTECTOR FOR PV

**Imax
40kA**

DS50PV/51

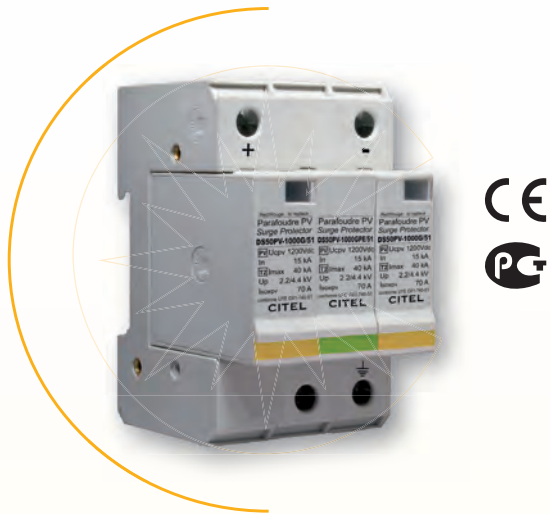

- Type 2 DC surge protector for PV installation
- Impulse currents I_{max}/I_n : 40/15 kA
- Pluggable module
- Remote signaling (option)
- UTE C61740-51 compliant

DS50PVS-xxxG/51

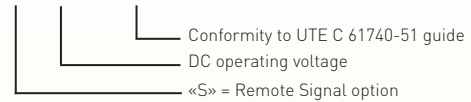

Dimensions and Diagram

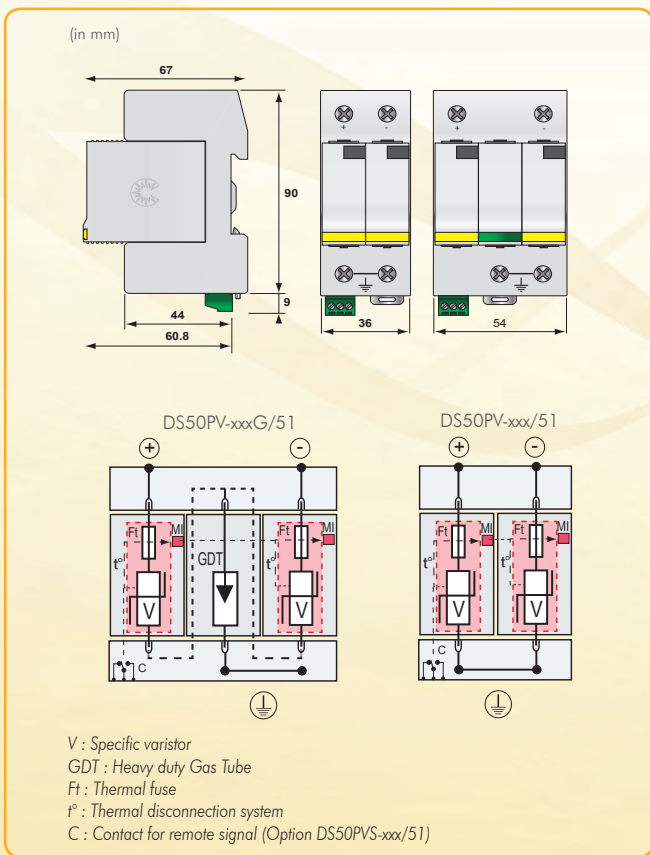

Characteristics

CITEL PART NUMBER		DS50PV-500/51	DS50PV-600/51	DS50PV-800G/51	DS50PV-1000G/51
Maximum PV tension	Uocstc	500 Vdc	600 Vdc	800 Vdc	1000 Vdc
Short circuit current	Iscwpv	70 A	70 A	70 A	70 A
Protection mode (see Note 1)		MC	MC	MC/MD	MC/MD
Max operating voltage	Ucpv	600 Vdc	720 Vdc	960 Vdc	1200 vdc
Leakage current	Ic	< 0.1 mA	< 0.1 mA	none	none
Nominal discharge current 15 x 8/20 μs impulses	I _n	15 kA	15 kA	15 kA	15 kA
Max. discharge current max. withstand 8/20 μs	I _{max}	40 kA	40 kA	40 kA	40 kA
Protection Level CM	U _p MC	2,2 kV	2,8 kV	2 kV	2,2 kV
Protection Level DM		-	-	3,6 kV	4,4 kV
Thermal disconnecter		internal			
Dimensions		see diagram			
Connection		by screw terminal: 4-25 mm ²			
End of life mode		disconnection of the SPD from PV line			
Disconnection indicator		by mechanical indicator			
Remote signaling of disconnection		Option DS50PVS-xxx/51 - output on changeover contact			
Mounting		on symmetrical rail 35 mm			
Operative temperature		-40/+85°C			
Protection class		IP 20			
Housing material		thermoplastic UL94-V0			
UTE C61740-51	France	DC SPD for PV - Class II Test			
prEN 50539-11	Europe	DC SPD for PV - Class II Test			
UL1449 3rd Ed. for PV	USA, Canada	Type 4, Type 2 Location			
CSA C22.2		Class 90941 32			

Note 1: MC = Common Mode (+/PE or -/PE) and MC/MD = Common Mode and Differential Mode (+/-)



Telecom & Data Line Overview

TELECOM & DATA LINE INTRODUCTION

Telecommunication and data transmission devices (PBX, modems, data terminals, sensors, etc...) are increasingly more vulnerable to lightning induced surge voltages. They have become more sensitive, complex and have an increased vulnerability to induced surge voltages due to their possible connection across several different networks. These devices are critical to communications and information processing. As such, it is prudent to insure them against these potentially costly and disruptive events. A telecom & data line surge protector installed in-line, directly in front of a sensitive piece of equipment will increase their useful life and maintain the continuity of the flow of your information.

TECHNOLOGY OF SURGE PROTECTORS

All Citel telecom and data line surge protectors are based on a reliable multistage hybrid circuit that combines heavy duty Gas Discharge Tubes (GDTs) and fast responding Silicon Avalanche Diodes (SADs). This type of circuit provides:

- 5 kA Nominal Discharge Current (15 times without destruction)
- Less than 1 nanosecond response time
- Very low protection level (Up)
- Fail-safe disconnection system
- Low capacitance design minimizing signal losses

INSTALLATION

To be effective, the surge protector must be installed in accordance with the following principles:

- The ground point of the surge protector and of the protected equipment must be bonded.
- The protection is installed at the service entrance of the installation to divert impulse current as soon as possible.
- The surge protector must be installed in close proximity, less than 90 feet (or 30 meters) from protected equipment. If this rule cannot be followed, secondary surge protectors must be installed closer to the equipment.
- The grounding conductor (between the earth output of the protector and the installation bonding circuit) must be as short as possible (less than 1.5 feet or 0.50 meters) and have a cross sectional area of at least 2.5 mm².
- The earth resistance must comply to the local electrical code. No special earthing is necessary.
- Protected and unprotected cables must be kept well apart to limit coupling.

SELECTING A TELECOM & DATA LINE SURGE PROTECTOR

To select the correct surge protector for your installation, the following information is needed:

- Type of line
- Maximum Line Voltage
- Maximum Line Current
- Maximum Data Transmission Speed
- Number of Lines
- Type of Connector (Screw Terminal, RJ connector...)
- Requested mounting (Din Rail, wall mounting)

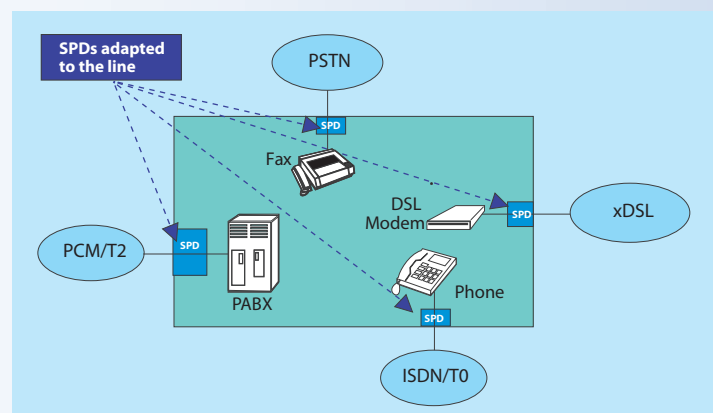

Standards

Test Standards and installation recommendations for communication line surge protectors must comply with the following standards :

- UL 497A : Secondary Protectors for Communications Circuits
- UL 497B : Protectors for Data and Fire-Alarm Circuits
- IEC 61643-21 : Tests of Surge Protectors for telecom Lines
- IEC 61643-22 : Selection/Installation of Surge Protectors
- ITU T K36 rec.

Special Conditions : Lightning Protection Systems

If the structure to be protected is equipped with a LPS (Lightning Protection System), the surge protectors for telecom or data lines that are installed at the buildings service entrance need to be tested to a direct lightning impulse 10/350µs wave form with a minimum surge current of 2.5 kA (D1 category test IEC 61643-21).

1 AND 2-PAIR PLUGGABLE SURGE PROTECTORS FOR DATA/TELECOM

**Imax
20kA**

DLA / DLA2



- Pluggable surge protection for DIN mounting
- I_{max} 20kA / I_n 5kA
- All types of Telephone and Data lines
- Shield wire protection
- 2-pair version (DLA2)

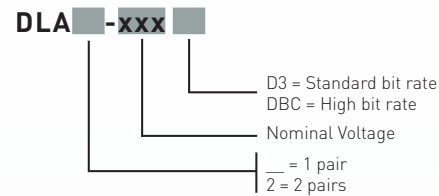

Dimensions and Diagram

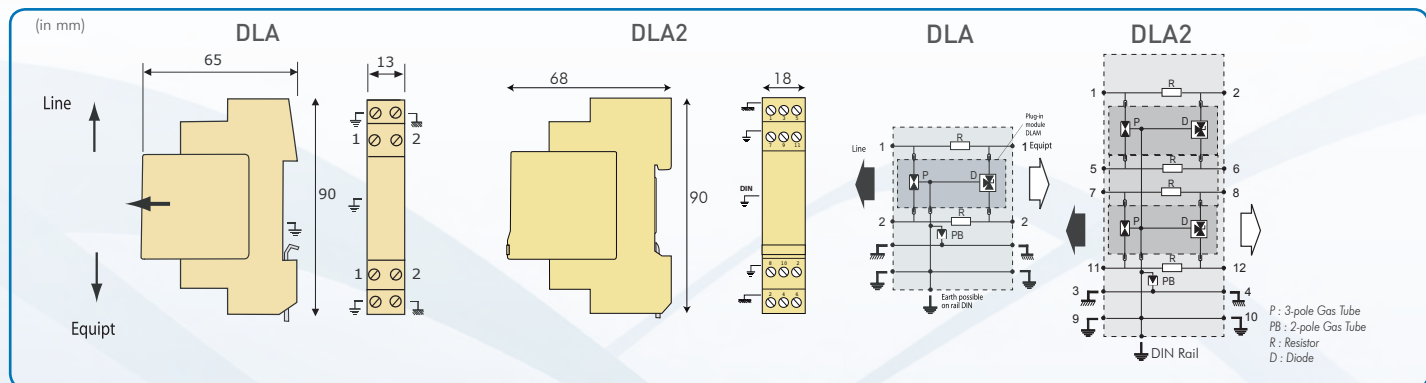

Characteristics

CITEL PART NUMBER	DLA-170, DLA2-170	DLA-48D3, DLA2-48D3	DLA-24D3, DLA2-24D3	DLA-12D3, DLA2-12D3	DLA-06D3, DLA2-06D3	DLA-06DBC, DLA2-06DBC
Typical application	Telephone line ADSL	48V line ISDN-T0	Leased line, 24V line, 4-20mA	Profibus-FMS, Interbus, Fielbus-H1, Batibus, RS232	RS422, RS485	6V line high bitrate, T2-T1 10BaseT, MIC/T2
Configuration	1 pair+shield (DLA) 2 pairs (DLA2)	1 pair+shield (DLA) 2 pairs (DLA2)	1 pair+shield (DLA) 2 pairs (DLA2)	1 pair+shield (DLA) 2 pairs (DLA2)	1 pair+shield (DLA) 2 pairs (DLA2)	1 pair+shield (DLA) 2 pairs (DLA2)
Nominal line voltage	U _n 150 V	48 V	24 V	12 V	6 V	6 V
Max. line voltage	U _c 170 V	53 V	28 V	15 V	8 V	8 V
Max. line current	I _L 300 mA	300 mA	300 mA	300 mA	300 mA	300 mA
Protection level 8/20 μs impulses - 5kA	U _p 220 V	70 V	40 V	30 V	20 V	25 V
Nominal discharge current 8/20 μs impulses - 10 times	I _n 5 kA	5 kA	5 kA	5 kA	5 kA	5 kA
Maximal discharge current 8/20 μs impulses - 1 time	I _{max} 20 kA	20 kA	20 kA	20 kA	20 kA	20 kA
Impulse current 10/350 μs impulses - 2 times	I _{imp} 5 kA	5 kA	5 kA	5 kA	5 kA	5 kA
End of life	short-circuit	short-circuit	short-circuit	short-circuit	short-circuit	short-circuit
Mechanical specifications	Symmetrical DIN rail mounting Dimensions : see drawing Connection by screw - min/max. cross section 0.4/1.5 mm ² Housing material : Thermoplastic UL94V0 Earth connection via DIN rail and screw terminal					

1 AND 2-PAIR SURGE PROTECTORS FOR DATA/TELECOM

**Imax
20kA**

DLU / DLU2



- Cost effective device
- I_{max} 20kA / I_n 5kA
- All types of Telephone and Data lines
- Shield wire protection
- 2-pair version (DLU2)

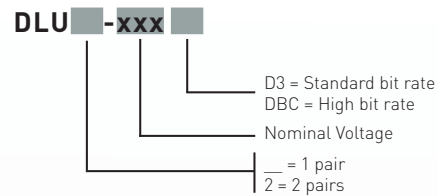

Dimensions and Diagram

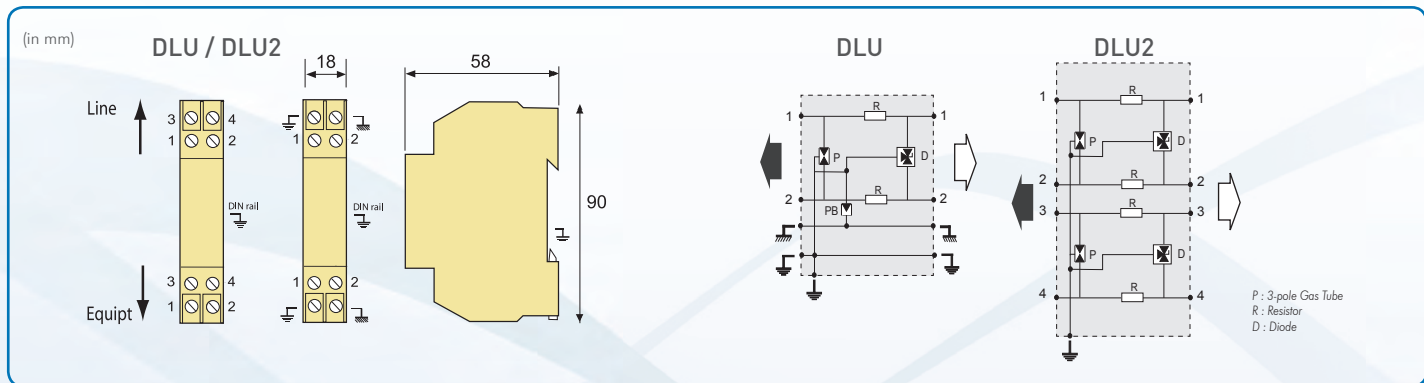

Characteristics

CITEL PART NUMBER	DLU-170, DLU2-170	DLU-48D3, DLU2-48D3	DLU-48DBC, DLU2-48DBC	DLU-24D3, DLU2-24D3	DLU-12D3, DLU2-12D3	DLU-12DBC, DLU2-12DBC	DLU-06D3, DLU2-06D3	DLU-06DBC, DLU2-06DBC
Typical application	Telephone line ADSL	48V line ISDN-T0	Fipway, WorldFIP, Fielbus-H2	Leased line, 24V line, 4-20mA	Profibus-FMS, Inter- bus, Fielbus-H1, Batibus, RS232	Profibus-DP, LONwork	RS422, RS485	6V line high bitrate, T2-T1 10BaseT, MIC/T2
Configuration	1 pair+shield (DLU) 2 pairs (DLU2)	1 pair+shield (DLU) 2 pairs (DLU2)	1 pair+shield (DLU) 2 pairs (DLU2)	1 pair+shield (DLU) 2 pairs (DLU2)	1 pair+shield (DLU) 2 pairs (DLU2)	1 pair+shield (DLU) 2 pairs (DLU2)	1 pair+shield (DLU) 2 pairs (DLU2)	1 pair+shield (DLU) 2 pairs (DLU2)
Nominal line voltage	U _n 150 V	48 V	48 V	24 V	12 V	12 V	6 V	6 V
Max. line voltage	U _c 170 V	53 V	53 V	28 V	15 V	15 V	10 V	10 V
Max. line current	I _L 300 mA	300 mA	300 mA	300 mA	300 mA	300 mA	300 mA	300 mA
Protection level	U _p 220 V	70 V	75 V	40 V	30 V	35 V	20 V	25 V
Nominal discharge current 8/20 μs impulses - 10 times	I _n 5 kA	5 kA	5 kA	5 kA	5 kA	5 kA	5 kA	5 kA
Maximal discharge current 8/20 μs impulses - 1 time	I _{max} 20 kA	20 kA	20 kA	20 kA	20 kA	20 kA	20 kA	20 kA
Impulse current 10/350 μs impulses - 2 times	I _{imp} 5 kA	5 kA	5 kA	5 kA	5 kA	5 kA	5 kA	5 kA
End of life	short-circuit	short-circuit	short-circuit	short-circuit	short-circuit	short-circuit	short-circuit	short-circuit
Mechanical specifications	Symmetrical DIN rail mounting Dimensions : see drawing Connection by screw - min/max. cross section 0.4/1.5 mm ² Housing material : Thermoplastic UL94V0 Earth connection via DIN rail (DLU, DLU2) and screw terminal (DLU)							

1, 2 AND 4-PAIR SURGE PROTECTORS FOR DATALINE/TELECOM

**I_{max}
20kA**

B180, B280, B480

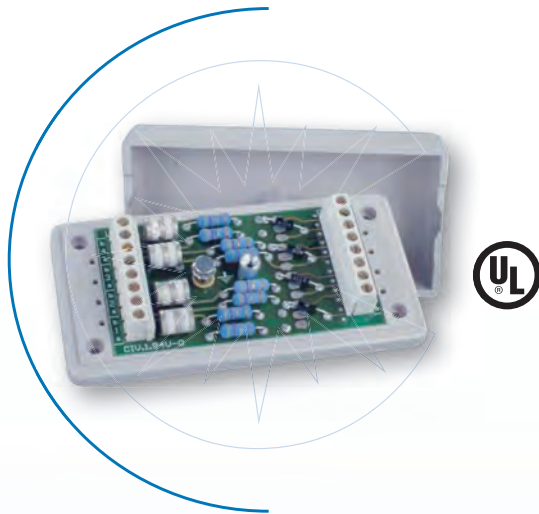

- 1, 2 or 4 pair protection units
- All types of telephone and data lines
- Removable protection circuit board
- Wall or surface mount
- Screw terminal connection

Dimensions and Diagram

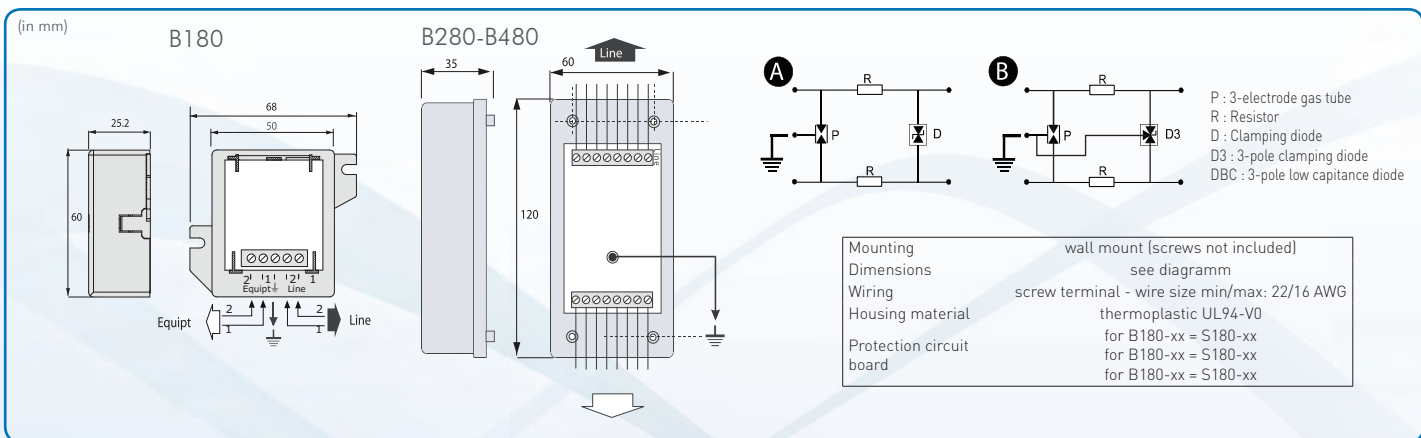

Characteristics

CONFIGURATION		CITEL PART NUMBER				
1-pair unit		B180-T	-	B180-24D3	B180-12D3	B180-06D3
2-pair unit		B280-T	B280-48D3	B280-24D3	B280-12D3	B280-06D3
4-pair unit		B480-T	B480-48D3	B480-24D3	B480-12D3	B480-06D3
Application		Telephone line / ADSL	ISDN-T0 / 48V line	4-20mA	RS232	RS422, T1, RS485, 10 Base T
Configuration protected						
- B180...		1 pair	-	1 pair	2 wires	1 pair
- B280...		2 pairs	1 channel	2 pairs	4 wires	2 pairs
- B480...		4 pairs	2 channels	4 pairs	8 wires	4 pairs / 2x2 pairs
Nominal line voltage	U _n	150V	48V	24V	12V	6V
Max. line voltage	U _c	170V	53V	28V	15V	8V
Protection level	U _p	220V	70V	40V	30V	20V
		<i>8/20µs impulse @ I_n</i>				
Nominal discharge current	I _n	5 kA	5 kA	5 kA	5 kA	5 kA
		<i>8/20µs impulse - 10 times</i>				
Max. discharge current	I _{max}	20 kA	20 kA	20 kA	20 kA	20 kA
		<i>8/20µs impulse - 10 times</i>				
Lightning current	I _{imp}	5 kA	5 kA	5 kA	5kA	5 kA
		<i>8/20µs impulse - 10 times</i>				
Type of diagram		A	B	B	B	B
End of life		short-circuit	short-circuit	short-circuit	short-circuit	short-circuit

D-SUB DATALINE SURGE PROTECTOR

DD

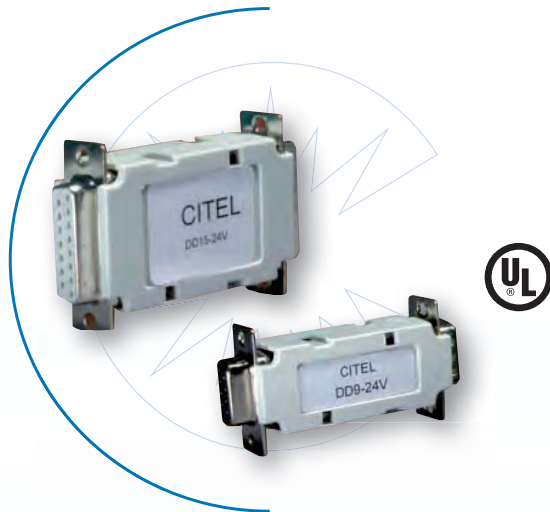

- «D-Sub» Surge Protectors
- For RS232, RS422, RS485 communication lines
- Fast & easy installation
- 9, 15 and 25-pin connectors

Dimensions and Diagram

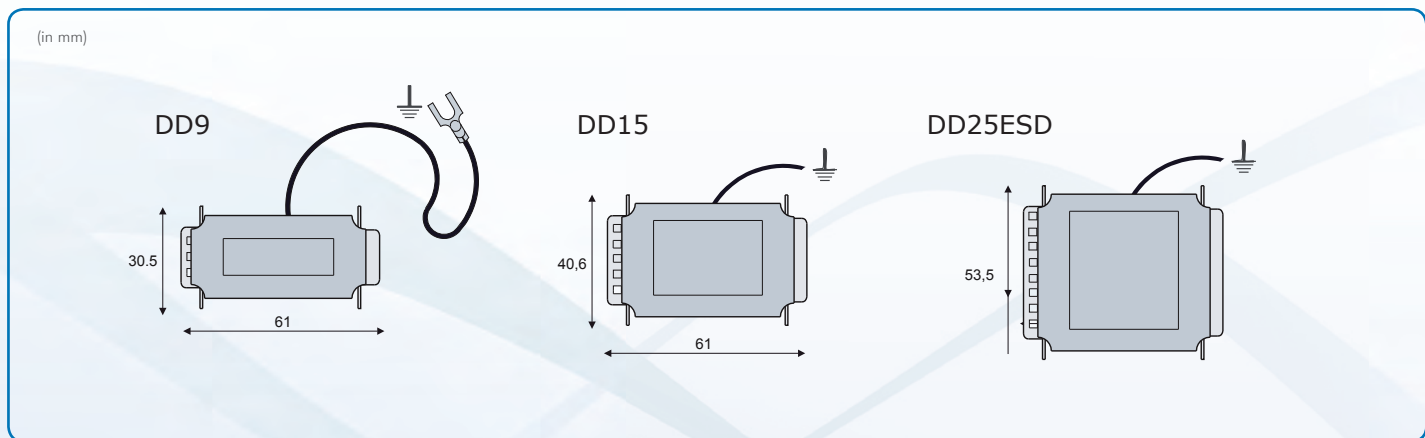

Characteristics

CITEL PART NUMBER	DDxx-6V*	DDxx-24V*
Application	RS422, RS485	RS232, 4-20mA
Connector D-Sub 25	DD25ESD-6V	DD25ESD-24V
Connector D-Sub 15	DD15-6V	DD15-24V
Connector D-Sub 9	DD9-6V	DD9-24V
Max. line voltage	Uc 6 V	15 V
Capacitance	<30 pF	<30 pF
Maximum data rate	<40 Mbps	<40 Mbps
Clamping voltage	Up 7.5 V	18 V
Nominal discharge current	In 400 A	300 A
Connector wiring	all wires transmitted and protected	all wires transmitted and protected
Mounting	on D-sub connector	on D-sub connector
Earthing	by wire	by wire
Housing material	thermoplastic	thermoplastic
Dimensions	see drawings	see drawings

*xx = 9, 15, 25 (pins)

TELECOM AND DATA SURGE PROTECTOR

MJ8 MJ6

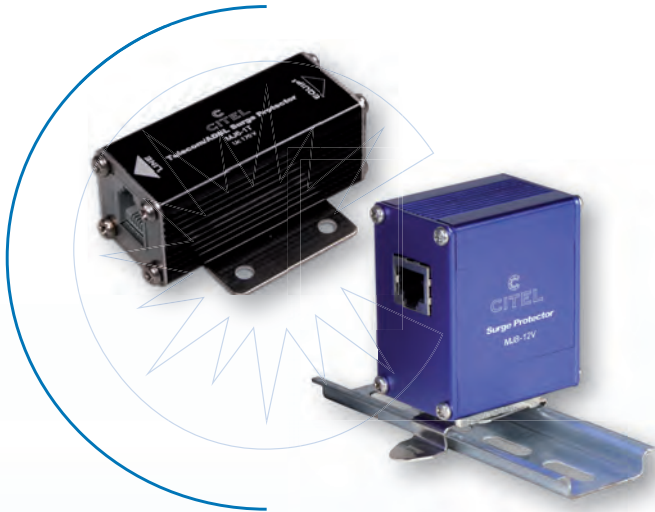

- MJ6 : RJ11 connectors
- MJ8 : Shielded enclosure and RJ45 connectors

Dimensions and Diagram

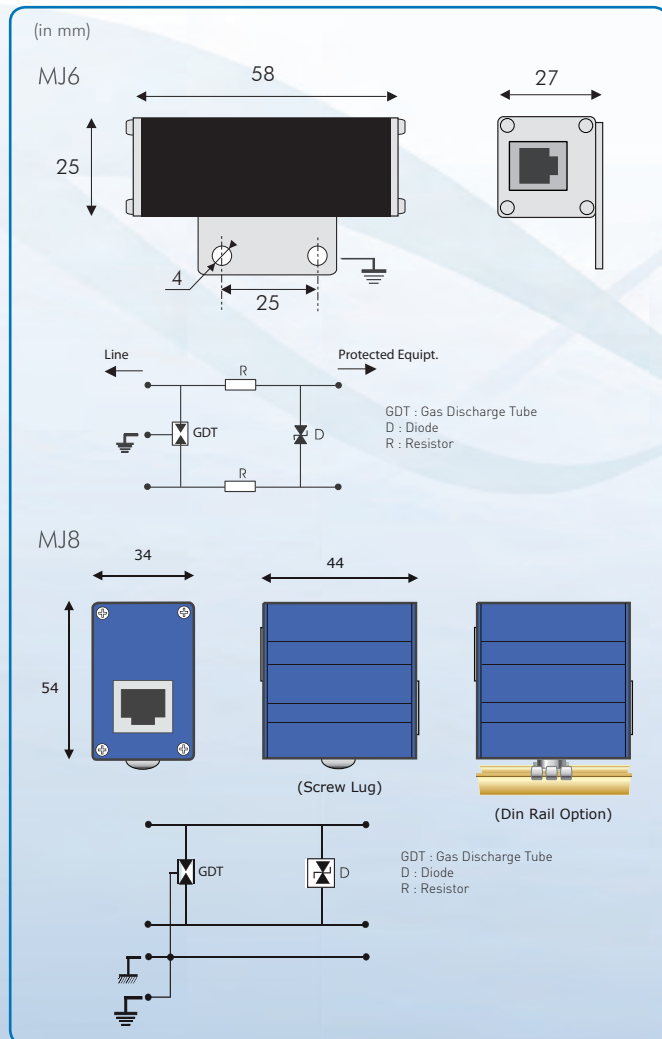

Characteristics

CITEL PART NUMBER	MJ6-1T	MJ8-12V	MJ8-2RN	MJ8-170V
Application	PSTN or ADSL 1-pair surge protection	12 V signal	ISDN	PSTN/ADSL
Max. data rate	30 Mbps	30 Mbps	30 Mbps	30 Mbps
Max. DC Signal	150 Vdc 300 mA	18 Vdc 600 mA	60 Vdc 600 mA	150 Vdc 600 mA
Pin outs	(1-3)	(1-2) (3-6) (4-5) (7-8)	(3-6) (4-5)	(1-2) (3-6) (4-5) (7-8)
Nominal discharge currents (@8/20 μ s)				
- Line/Line	<2500 A		<500 A	
- Line/Ground	2500 A		2000 A	
Connections:				
- Input	RJ11		Shielded RJ45 Connectors	
- Output	RJ11		Shielded RJ45 Connectors	
Pin out	1 pair	4 pairs	2 pairs	4 pairs
Enclosure	Metal			
Ground Connection	Mounting Flange, Ground wire	Screw Lug, Din Rail Clip or Mounting Flange		
Standard Compliance	IEC 61643-21			

CAT-5E AND CAT6 SURGE PROTECTOR

MJ8-CAT5E MJ8-C6



- 10/100/1000 Base T compatible
- Shielded enclosure and RJ45 connectors
- Bi-directional

Dimensions and Diagram

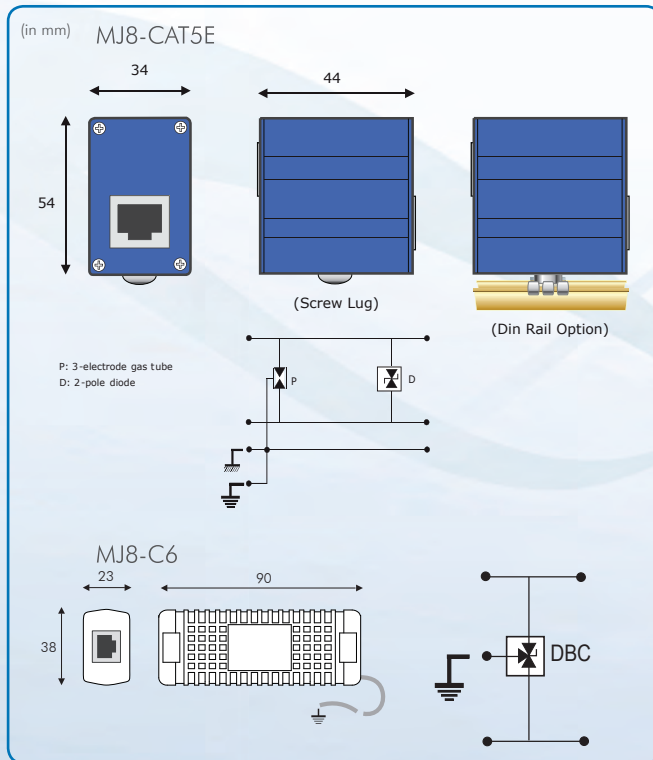

Characteristics

CITEL PART NUMBER	MJ8-CAT5E	MJ8-C6
Application	Ethernet	Ethernet Cat.6
Max. data rate	1000 Mbps	1000 Mbps
Max. DC Signal	8 Vdc 600 mA	6 Vdc
Pin outs	(1-2) (3-6) (4-5) (7-8)	
Nominal discharge currents:		
- Line/Line	<500 A @ 8/20 μ s	<100 A @ 8/20 μ s
- Line/Ground	2000 A @ 8/20 μ s	100 A @ 8/20 μ s
Connections:		
- Input	Shielded RJ45 Connectors	RJ45 Connectors
- Output	Shielded RJ45 Connectors	RJ45 Connectors
Pin out	4 pairs + shielding + ground	4 pairs + ground
Enclosure	Metal	Plastic
Ground Connection	Screw Lug, Din Rail Clip or Mounting Flange	Ground wire
Standard Compliance	IEEE 802-3af and 3av (transmission) IEC 61643-21 (surge withstand)	

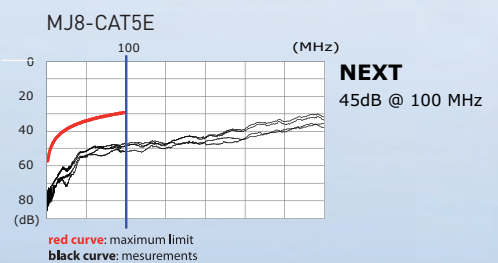
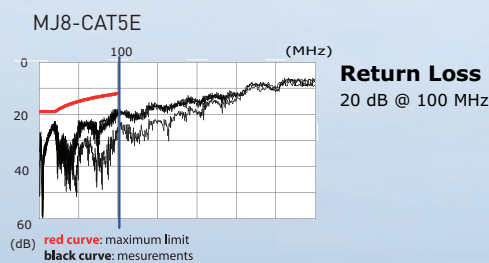
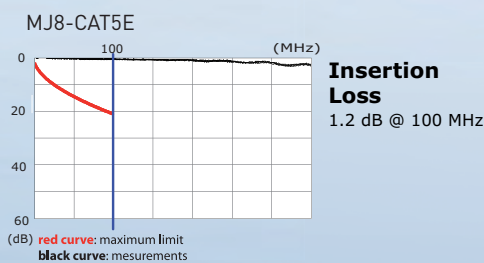

GIGABIT POWER-OVER-ETHERNET (POE) SURGE PROTECTOR

**Imax
2kA**

MJ8-POE

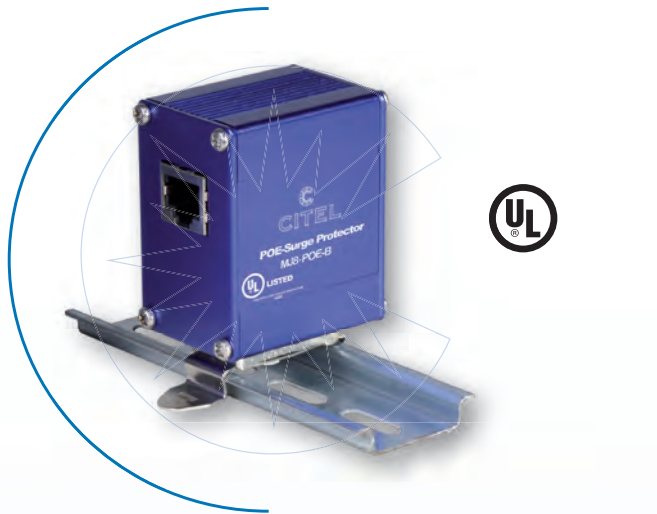

- POE compatible
- Shielded enclosure and connectors
- 2 kA discharge capability

Dimensions and Diagram

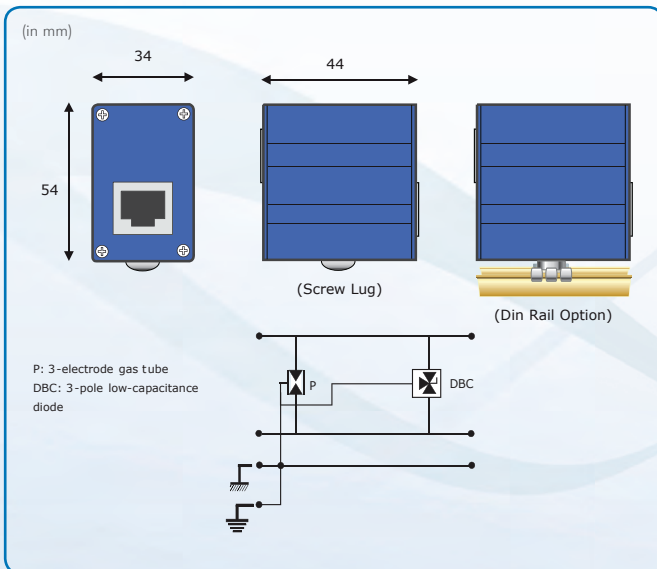

Characteristics

CITEL PART NUMBER	MJ8-POE-A	MJ8-POE-B
Application	PoE and Gigabit Ethernet Networks	
Max. data rate	1000 Mbps	1000 Mbps
Standard Compliance	IEEE 802-3af (transmission) IEC 61000-4-5 (surge withstand)	
Connections:		
- Input	RJ45 shielded	RJ45 shielded
- Output	RJ45 shielded	RJ45 shielded
Pinout	8 wires + shielding	8 wires + shielding
Max. DC Power Supply	60 Vdc - 650 mA	7.5 Vdc (1,2,3,6) - 650 mA 60 Vdc (4,5,7,8) - 650 mA
Nominal discharge currents:		
- Line/Line	<500 A @ 8/20 μ s	<500 A @ 8/20 μ s
- Line/Ground	2000 A @ 8/20 μ s	2000 A @ 8/20 μ s
Enclosure	Metal	
Ground Connection	Screw Lug, Din Rail Clip or Mounting Flange	
Standard Compliance	IEEE 802-3af (transmission)	

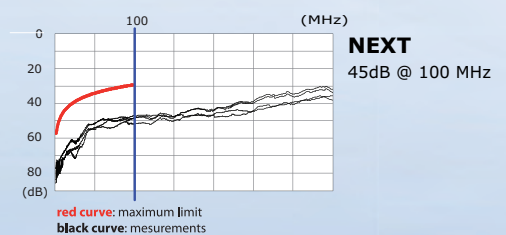
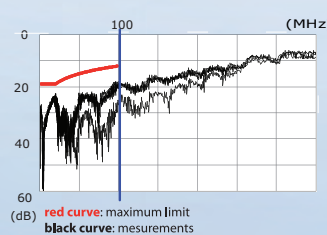
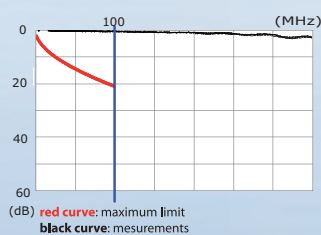

OUTDOOR GIGABIT POWER-OVER-ETHERNET (POE) SURGE PROTECTOR

**I_{max}
2kA**

CMJ8-POE



- Outdoor application and POE compatible
- Shielded RJ45 connectors
- 2 kA discharge capability

Dimensions and Diagram

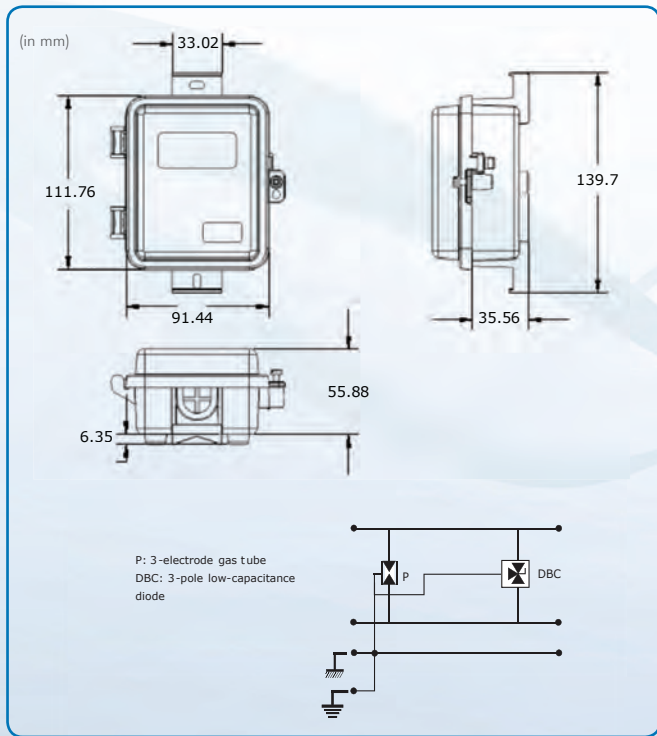

Characteristics

CITEL PART NUMBER	CMJ8-POE-A	CMJ8-POE-B
Application	PoE and Gigabit Ethernet Networks	
Max. data rate	1000 Mbps - CAT 5E	1000 Mbps - CAT 5E
Standard Compliance	IEEE 802-3af (transmission) IEC 61000-4-5 (surge withstand)	
Connections:		
- Input	RJ45 shielded	RJ45 shielded
- Output	RJ45 shielded	RJ45 shielded
Pinout	8 wires + shielding	8 wires + shielding
Max. DC Power Supply	60 Vdc - 650 mA	7.5 Vdc (1,2,3,6) - 650 mA 60 Vdc (4,5,7,8) - 650 mA
Nominal discharge currents:		
- Line/Line	<500 A @ 8/20 μs	<500 A @ 8/20 μs
- Line/Ground	2000 A @ 8/20 μs	2000 A @ 8/20 μs
PCB part #	CMJ8-POE-A/PCB	CMJ8-POE-B/PCB
Protection class	IP65	IP65
Connecting to bonding network	Screw Terminal	Screw Terminal

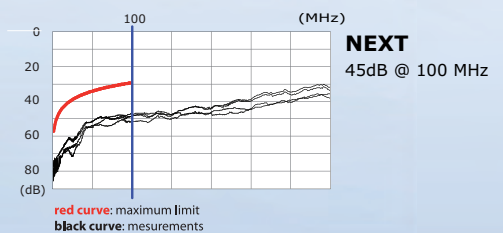
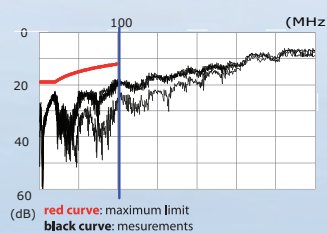
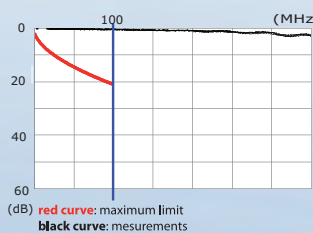

19" PATCH PANEL SURGE PROTECTOR FOR DATA / TELECOM

RAK

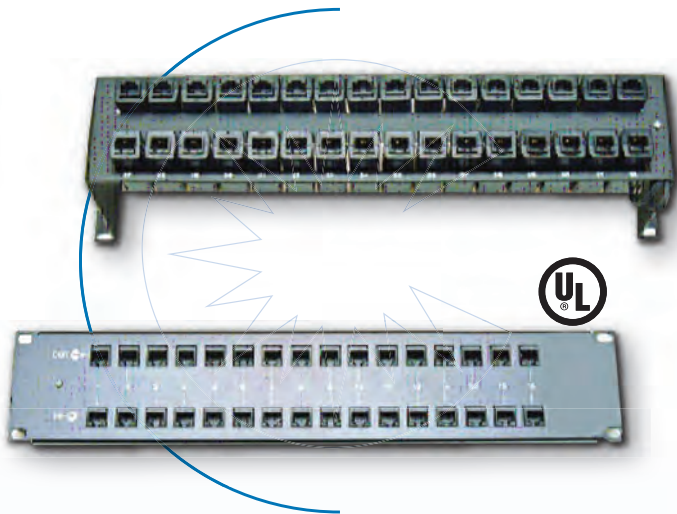

Dimensions and Diagram

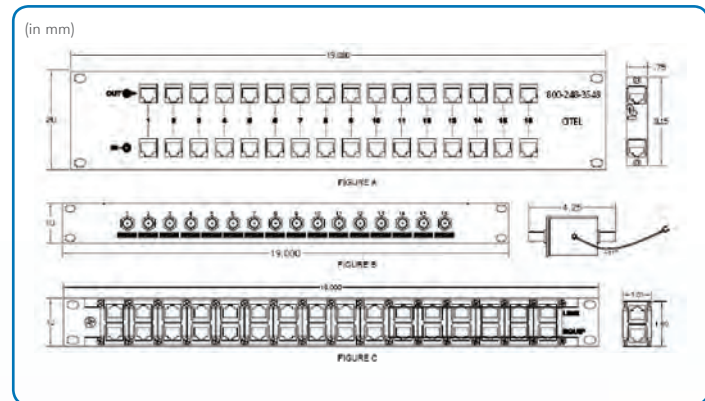

Electrical Specifications

	100BASE T RS422, RS485, RS423, Ethernet	RS232	ISDN, T1, DDS (fused)	Dial-up/ Modem/Fax (fused)	Power over Ethernet	CCTV	Cable TV/Satel- lite
Clamping Voltage	7.5 Volts	18 V	60 V	240 V	Pins 1, 2, 3, 6 = 7.5 V Pins 4, 5, 7, 8 = 60 V	7.5 V	90 V
Nominal discharge current	132 A	60 A	50 A	75 A	Pins 1, 2, 3, 6 = 132 A Pins 4, 5, 7, 8 = 50 A	132 A	20 kA
Response Time	----- LESS THAN 5 NANoseconds -----						
Capacitance	<40 pF	<40 pF	< 7.5pF	< 95pF	< 25pF (Ethernet lines)	< 30pF	1pF

Ordering Information

		100BASE T RS422, RS485, RS423, Ethernet	RS232	ISDN, T1, DDS (fused)	Dial-up/Modem/ Fax (fused)	Power over Ethernet	CCTV	Cable TV/ Satellite
16 port flush mount unit (figure A)	All Pins	1000BT-RAK16	RS232-RAK16	T1-RAK16	X	POE-RAK16-60V B	X	X
	Center 2 Pins	X	X	X	TEL-RAK16	X	X	X
16 port stand-off unit	All Pins	1000BT-RAK16	RS232-RAK16-SO	T1-RAK16-SO	X	X	X	X
	Center 2 Pins	X	X	X	TEL-RAK16-SO	X	X	X
32 port stand-off unit	All Pins	1000BT-RAK16	RS232-RAK32-SO	T1-RAK32-SO	X	X	X	X
	Center 2 Pins	X	X	X	TEL-RAK32-SO	X	X	X
16 port flush mount unit (figure B)	Coax	X	X	X	X	X	CCTVRAK16	CATV-RAK16
16 port flush mount unit front accessible modules (figure C)	X	X	X	T1-RAK16-1U	X	X	X	X



Coaxial Overview

RF SURGE PROTECTION TECHNOLOGY

Radio communication equipment deployed for mobile applications is especially vulnerable to lightning strikes because of their location in exposed areas. The most common disruption to service continuity result from transient surges originating from direct lightning strikes to the antenna pole, surrounding ground system or induced onto connections between these two areas.

Radio equipment utilized in CDMA, GSM/UMTS, WiMAX or TETRA base stations, must consider this risk in order to insure uninterrupted service. CITEL offers three specific surge protection technologies for Radio Frequency (RF) communication lines that are individually suited for the different operational requirements of each system.

Gas Tube DC Pass Protection P8AX series

Gas Discharge Tube (GDT) DC Pass Protection is the only surge protection component usable on very high frequency transmission (up to 6.9GHz) due to its very low capacitance. In a GDT based coaxial surge protector, the GDT is connected in parallel between the central conductor and the external shield. The device operates when its sparkover voltage is reached, during an overvoltage condition and the line is briefly shorted (arc voltage) and diverted away from sensitive equipment. The sparkover voltage depends on the rise front of the overvoltage. The higher the dV/dt of the overvoltage, the higher the sparkover voltage of the surge protector. When the overvoltage disappears, the gas discharge tube returns to its normal passive, highly insulated state and is ready to operate again. The GDT is held in a specially designed holder that maximizes conduction during large surge events and still very easily removed if maintenance is required due to an end of life scenario. The P8AX Series can be used on coaxial lines running DC voltages up to +/- 48V DC.

Hybrid DC Blocked Protection CXP-DCB series

Hybrid DC Blocked Protection is an association of filtering components and a heavy duty gas discharge tube (GDT). This design provides an excellent low residual let-through voltage for low frequency disturbances due to electrical transients and still provides a high surge discharge current capability.

Quarter Wave DC Blocked Band Pass Filter PRC series

Quarter Wave DC Blocked Protection is an active band pass filter. It has no active components. Rather the body and corresponding stub are tuned to one quarter of the desired wave length. This allows only a specific frequency band to pass through the unit. Since lightning operates only on a very small spectrum, from a few hundred kHz to a few MHz, it and all other frequency's are shortcircuited to ground.

The PRC technology can be selected for a very narrow band or wide band depending on the application. The only limitation for surge current is the associated connector type.

Typically, a 7/16 Din connector can handle 100 kA 8/20 μ s while an N-type connector can handle up to 50 kA 8/20 μ s.

Selecting a Coaxial Surge Protector

The information required to properly select a surge protector for your application is the following:

- Frequency Range
- Line Voltage
- Connector Type
- Gender Type
- Mounting
- Technology

INSTALLATION

The proper installation of a coaxial surge protector is largely dependent on its low impedance connection to the grounding network.

The following rules must be strictly observed:

Equipotential Grounding System

All the bonding conductors of the installation must be interconnected to each other and connected back to the grounding system.

Low Impedance Connection

The coaxial surge protector needs to have a low resistance connection to the Ground System. if the connection is performed by wire, it must 0.5 m long maximum.

Location of Protection

The protectors should be placed at the entrance of installation to limit the penetration of lightning current inside the facility. In addition, a second layer of protection directly in front of the sensitive equipment further increases the system reliability.

Mounting options include:

1) Feed through Mounting by Bulkhead or Mounting Bracket: This is the direct mounting of the surge protector onto the ground frame or ground plate at the installations service entrance.

- Provides perfect connection to the grounding system.
- Located at optimal point where surge currents enter at the entrance of the installation.
- Good mechanical withstand capability.

2) Ground Screw: Connection to the grounding system is made directly by wire via ground screw on the chassis and then connected to grounding system (4 mm² minimum - 0.5 m long max.).

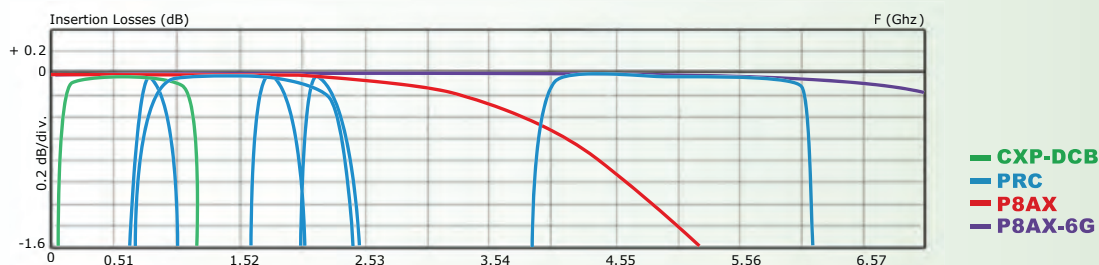

UNIVERSAL GAS TUBE COAXIAL SURGE PROTECTORS

4 GHz

P8AX



- I_{max} 20 kA @ 8/20μs
- I_{imp} 5 kA @ 10/350μs
- DC Pass to +/-48V
- VSWR < 1.2
- Insertion Loss < 0.2dB
- Bi-directional, series installed
- Waterproof
- Removable GDT

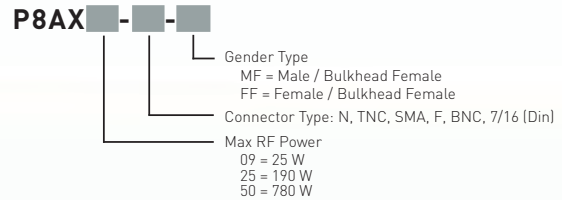

Dimensions

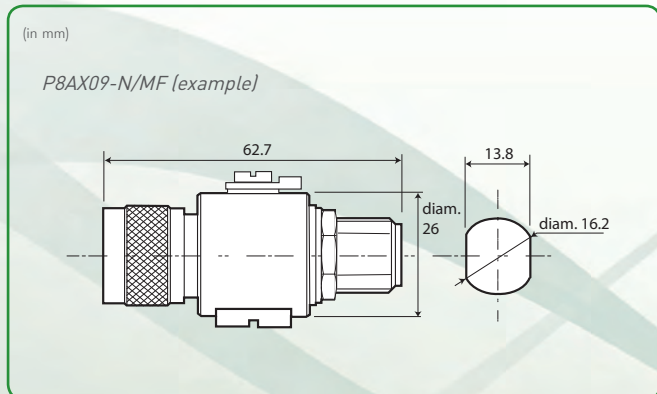

Characteristics

CITEL PART NUMBER	P8AX09	P8AX25	P8AX50
Frequency Range	DC-4GHz	DC-4GHz	DC-4GHz
Technology	Gas Discharge Tube		
Insertion Loss	≤0.2db		
Return Loss	≥20 db		
VSWR	<1.2:1		
Discharge current (8/20 μs)	20kA		
Protection level	<600 V	<600 V	<1000 V
Max Power	25 W	190 W	780 W
Max Current	10 A		
Impedance	50 ohms ¹		
Connection Method	Series (bi-directional)		
Connectors	N, TNC, SMA, F, BNC, 7/16		
Grounding	M6 Screw, Bulkhead, Bracket		
Environmental Rating	IP65		
Operating Temp	-50°C to +85°C		
Operating Altitude	4,000 m		
Relative Humidity	up to 5 to 95% non-condensing, up to 100%		

¹ Impedance for F-Type Connector is 75 ohms

Applications

- Tower Mounted Amplifiers (TMA)
- Global Positioning Systems (GPS)
- Antenna Systems
- Tower Top Electronics (TTE)
- Transmitters and Receivers
- WiFi
- Broadband Wireless
- WiMax Broadband wireless

HIGH FREQUENCY GAS TUBE COAXIAL SURGE PROTECTORS

6 GHz

P8AX-6G



- DC to 6 GHz
- I_{max} 20 kA @ 8/20μs
- DC Pass to +/-48V
- VSWR < 1.25
- Insertion Loss < 0.2dB
- Waterproof
- Removable GDT

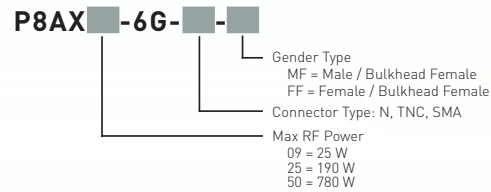

Dimensions

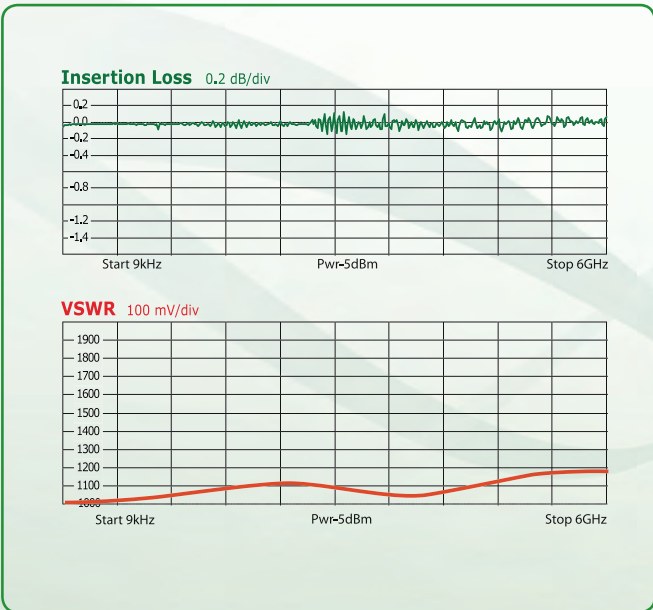

Characteristics

CITEL PART NUMBER	P8AX09-6G	P8AX25-6G	P8AX50-6G
Frequency Range	DC-6GHz		
Technology	Gas Discharge Tube		
Insertion Loss	≤0.2db		
Return Loss	≥19 db		
VSWR	<1.25:1		
Discharge current (8/20 μs)	20kA		
Protection level	< 600 V	< 600 V	< 1000 V
Max Power	25W	190W	780W
Max Current	10A		
Impedance	50 ohms		
Connection Method	Series (bi-directional)		
Connectors	N, TNC, SMA		
Grounding	M6 Screw, Bulkhead, Bracket		
Environmental Rating	IP65		
Operating Temp	-50°C to +85°C		
Operating Altitude	4,000m		
Relative Humidity	up to 5 to 95% non-condensing, up to 100%		

Applications

- Multi-Point Radio & Backhaul Bridges
- Tower Mounted Amplifiers (TMA)
- Antenna Systems
- Tower Top Electronics (TTE)
- Transmitters and Receivers
- WiFi
- WiMax Broadband wireless



QUATER WAVE STUB COAXIAL SURGE PROTECTORS

PRC

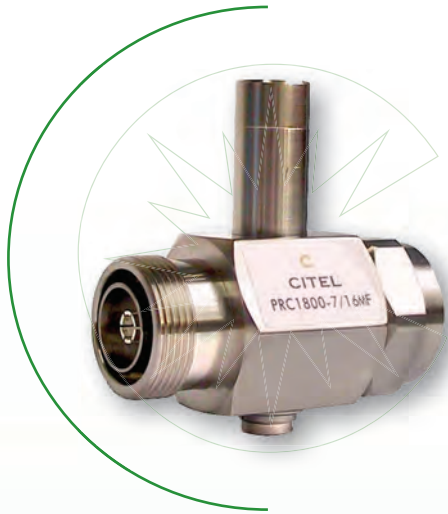

- I_{max} 100 kA @ 8/20μs
- Guaranteed lifetime warranty
- No signal loss
- Available for wide-band applications

Dimensions

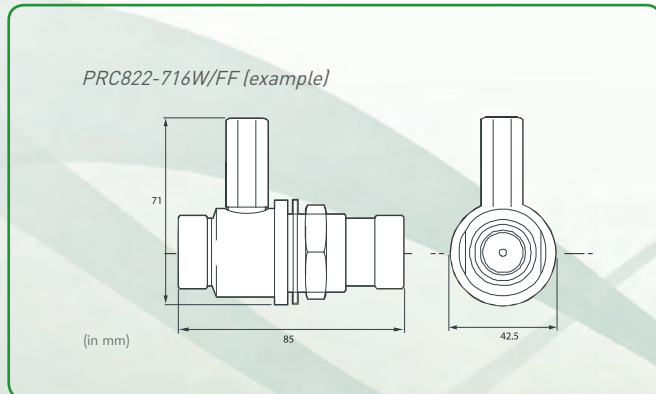

Characteristics

CITEL PART NUMBER	PRC822	PRC900	PRC1800	PRC2100	PRC5800
Frequency Range	800-2200MHz	870-960MHz	1700-1950MHz	1800-2400MHz	4500-6000MHz
Technology	Frequency Filter				
Insertion Loss	≤0.15 db	≤0.15 db	≤0.15 db	≤0.12 db	≤0.20 db
Return Loss	≥20 db				
VSWR	<1.2:1				
Max. Discharge current (8/20 μs)	100 kA (50 kA N&TNC)	100kA (50 kA N&TNC)	100kA (50 kA N&TNC)	50 kA (50 kA N&TNC)	50 kA (50 kA N&TNC)
Max Power	2500 W (1500 W for N &T NC)	2500 W (1500 W for N &T NC)	2500 W (1500 W for N &T NC))	1500 W	1500 W
Max Current	N/A				
Impedance	50 ohms				
Connection Method	Series				
Connectors	7/16	7/16, N, TNC	7/16, N, TNC	N	N
Grounding	M6 Screw, Bulkhead, Bracket				
Environmental Rating	IP65				
Operating Temp	-50°C to +85°C				
Operating Altitude	4,000 m				
Relative Humidity	up to 5 to 95% non-condensing, up to 100%				



HYBRID COAXIAL SURGE PROTECTORS

CXF60-N



- Low Frequency Coaxial Surge Protection
- I_{max} 6 kA
- up to 60 Vdc
- RoHS 6 compliant
- Bi-directional, series installed
- Waterproof

Dimensions

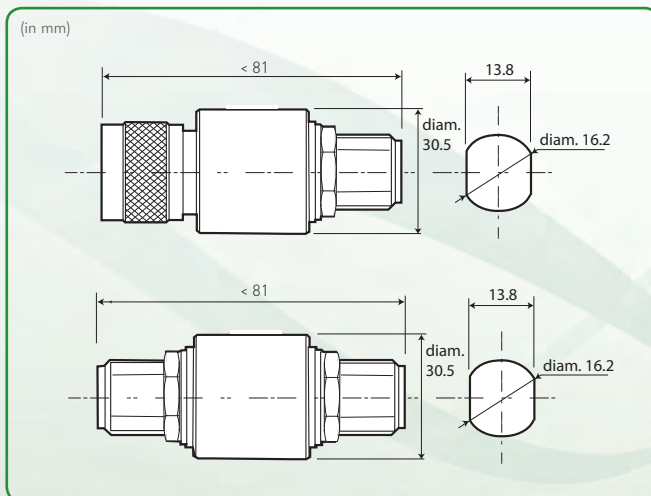

Characteristics

CITEL PART NUMBER	CXF60
Frequency range	DC-500MHz
Max. peak input power	50 dBm
Impedance	50 ohms
Max current	6A dc
Max voltage	up to 60 Vdc any polarity
Max. discharge current (8/20 μ s)	6kA
Standard compliance	IEC standard 60529 IP67
Operating temperature	-50°C to +85°C
Relative humidity	up to 5 to 95% non-condensing, up to 100%
Bellcore standard	TA-NWT-000487 procedure 4.11
RoHS compliance	RoHS 6 compliant
Connection method	Series (bi-directional)
Connectors	N-Male to N-Female Bulkhead & N-Female to N-Female Bulkhead

Applications

- Multi-Point Radio & Backhaul Bridges
- Tower Mounted Amplifiers (TMA)
- Global Positioning Systems (GPS)
- Antenna Systems
- Tower Top Electronics (TTE)
- Transmitters and Receivers
- WiFi
- WiMax Broadband wireless

HYBRID COAXIAL SURGE PROTECTORS

CXC / CNP



- Coaxial Surge Protection
- High discharge current up to 20kA
- Low residual voltage
- Compact design
- Easy mounting

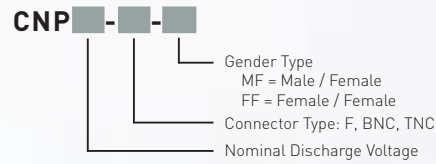

Dimensions

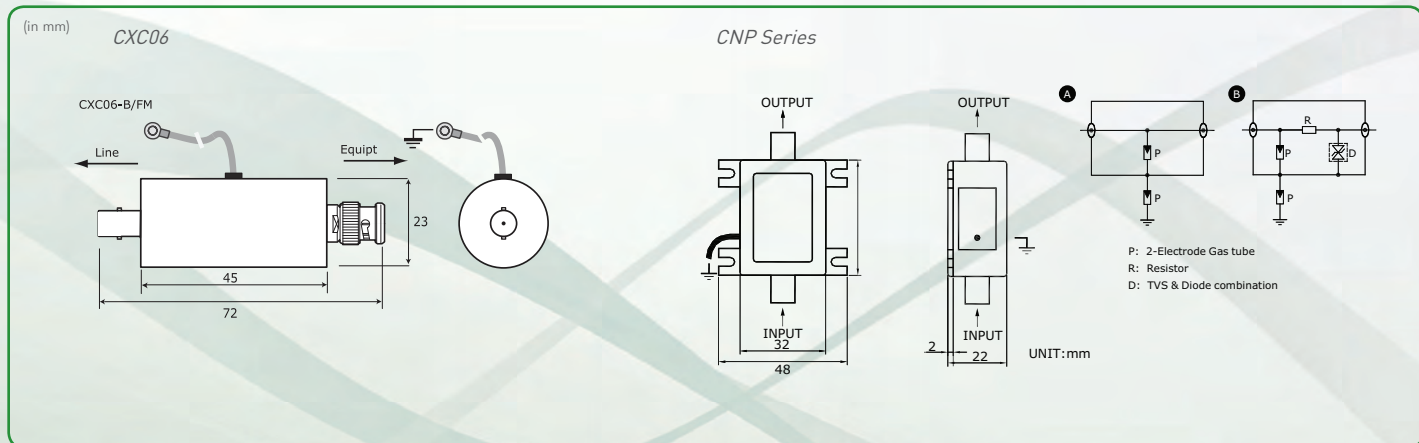

Characteristics

CITEL PART NUMBER	CXC06	CNP06	CNP90	CNP90TV	CNP230TV
Frequency Range	DC-70MHz	DC-100MHz	DC-100MHz	DC-1GHz	DC-1GHz
Technology	Hybrid DC Pass	Hybrid DC Pass	Hybrid DC Pass	Gas Discharge Tube	Gas Discharge Tube
Insertion Loss	≤0.6 dB	≤0.5 dB	≤0.5 dB	≤0.5 dB	≤0.5 dB
Return Loss	≥20 dB	>20 dB	>20 dB	>20 dB	>20 dB
VSWR			<1.2:1		
Max. Discharge current (8/20 μs)	10 kA	20 kA	20 kA	20 kA	20 kA
Max Power	100 W	100 W	100 W	100 W	100 W
Max Current	6 A	4 A	4 A	0.5 A	0.5 A
Impedance	50 ohms	50/75 ohms	50/75 ohms	75 ohms	75 ohms
Connectors	BNC, F	BNC, TNC	BNC, TNC	BNC, F, TNC	BNC, F, TNC
Grounding			Ground wire		
Environmental Rating	IP65	IP20	IP20	IP20	IP20
Operating Temp			-50°C to +85°C		
Operating Altitude			4,000 m		
Relative Humidity			up to 5 to 95% non-condensing, up to 100%		



Gas Discharge Tube Overview

PROTECTION FOR PC BOARD LEVEL COMPONENTS

Today's microprocessor based electronic equipment are increasingly more vulnerable to lightning induced voltage surges and electrical switching transients because they have become more sensitive, and complex to protect due to their high chip density, binary logic functions and connection across different networks. These devices are critical to a company's communications and information processing and typically can have an impact on the bottom line; as such it is prudent to insure them against these potentially costly and disruptive events. A Gas Discharge Tube (GDT) can be used as a stand-alone component or combined with other components to make a multistage protection circuit, the gas tube acts as the high energy handling component.

GDT's are typically deployed in the protection of communication and data line DC voltage applications because of its very low capacitance. However, they provide very attractive benefits on the AC power line including no leakage current, high energy handling and better end of life characteristics.

GAS DISCHARGE TUBE TECHNOLOGY

The gas discharge tube may be regarded as a sort of very fast switch having conductance properties that change very rapidly, when breakdown occurs, from open-circuit to quasi-short circuit (arc voltage about 20 V). There are accordingly four operating domains in the behavior of a gas discharge tube:

- **Non-operating domain:** Characterized by practically infinite insulation resistance.
- **Glow domain:** At the breakdown, the conductance increases suddenly. If the current is drained off by the gas discharge tube is less than about 0.5 A (rough value that differs from component to component) , the glow voltage across the terminals will be in the 80-100 V range.
- **Arc regime:** As the current increases, the gas discharge tube shifts from glow voltage to the arc voltage (20 V). It is this domain that the gas discharge tube is most effective because the current discharge can reach several thousand amperes without the arc voltage across the terminals increasing.
- **Extinction:** At a bias voltage roughly equal to the glow voltage, the gas discharge tube recovers to its initial insulating properties.

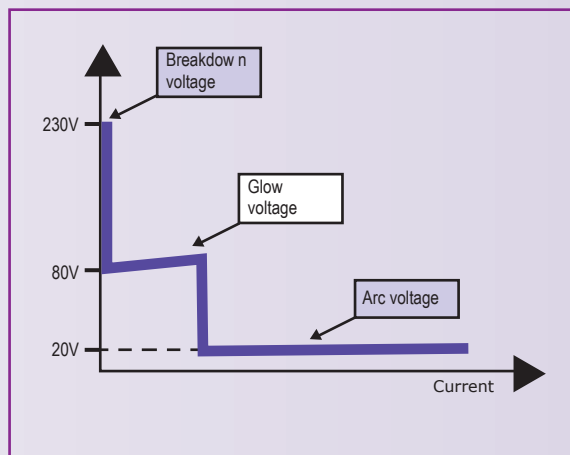

Operating curve

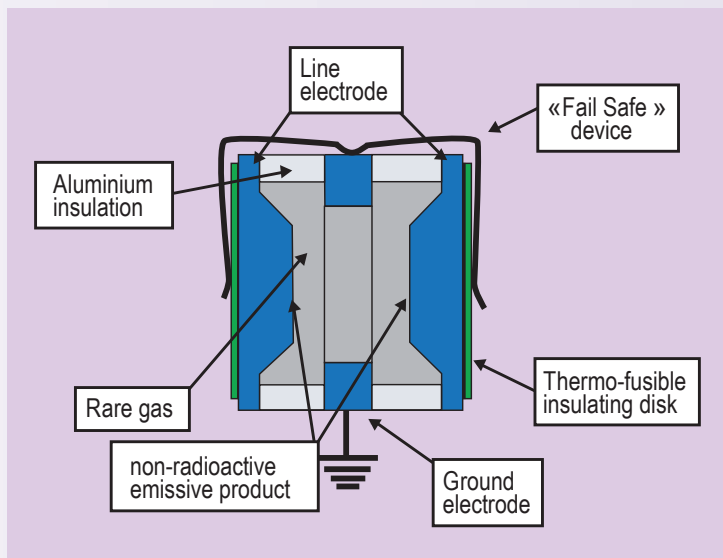

3-electrode gas tube description

SELECTING A GAS DISCHARGE TUBE

The information required to properly select a surge protector for your application is the following:

- DC sparkover voltage (Volts)
- Impulse sparkover voltage (Volts)
- Discharge current capacity (kA)
- Insulation resistance (Gohms)
- Capacitance (pF)
- Mounting (Surface Mount, Standard Leads, Custom Leads, Holder)
- Packaging (Tape & Reel, Ammo pack)

DC sparkover voltage

This is the main characteristic defining the gas discharge tube. It is the voltage at which breakdown will occur between the electrodes when a slowly increasing voltage ($dV/dt = 100 \text{ V/s}$) is applied to the component; it depends on the electrode spacing, the pressure, and the properties of the gas mixture and of the emissive substance.

Range of DC sparkover voltages available:

- Minimum 75 V
- Average 230 V
- High Voltage 500 V
- Very High Voltage 1000 to 3000 V

Tolerance on the DC breakdown voltage is generally +/-20%

Gas Discharge Tube Overview

Impulse Sparkover Voltage

The sparkover voltage in the presence of a steep front ($dV/dt = 1 \text{ kV}/\mu\text{s}$); the impulse sparkover voltage increases with the increasing dV/dt .

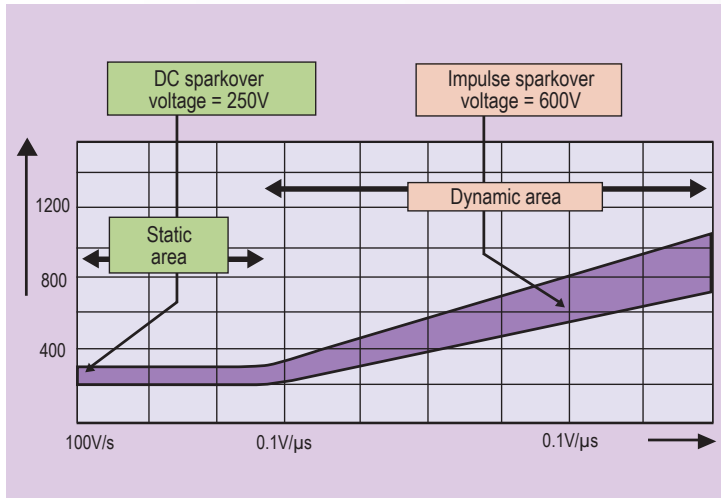

DC and impulse sparkover voltages

Discharge Current

Discharge current depends on the properties of the gas, the volume and the material of the electrode plus its treatment. This is the major characteristic of the GDT and the one that distinguishes it from the other surge protection devices, i.e. Varistors, Zener Diodes, etc... Typical value is 5 to 20 kA with an 8/20 μs impulse for standard components.

This is the value the gas discharge tube can withstand repeatedly (minimum 10 impulses) without the destruction or alteration of its basic specifications.

Insulation Resistance and Capacitance

These characteristics make the gas discharge tube practically invisible during normal operating conditions. The insulation resistance is very high (>10 Gohm) while the capacitance is very low (<1 pF).

3-ELECTRODE CONFIGURATION

Protecting a two line wire (for example a telephone pair) with two 2-electrode gas discharge tubes may cause the following problem:

If the protected line is subjected to an overvoltage in the common mode, the dispersion of the sparkover voltages (+/- 20%), one of the gas discharge tubes sparks over a very short time before the other (typically a few microseconds), the wire that has the sparkover is therefore grounded (neglecting the arc voltages), turning the common-mode overvoltage into a differential mode overvoltage. This is very dangerous for the protected equipment. The risk disappears when the second gas discharge tube arcs over (a few microseconds later).

The 3-electrode geometry eliminates this drawback. The sparkover of one pole causes a general breakdown of the device almost immediately (a few nanoseconds) because there is only one gas filled enclosure housing all the electrodes.

END OF LIFE

Gas discharge tubes are designed to withstand many impulses without destruction or loss of the initial characteristics (typical impulse tests are 10 times x 5 kA impulses for each polarity).

On the other hand, a sustained very high current, i.e. 10 A rms for 15 seconds, will simulate the dropping out of the AC power line onto a telecommunication line and will take the GDT immediately out of service.

If a fail-safe end of life is desired, i.e. short circuit that will report a fault to the end user when the line fault is detected, the gas discharge tube with the fail-safe feature (external short-circuit) should be selected.

STANDARDS

CITEL gas discharge tubes comply with the specifications of main telecom operators and with the ITU-T K12 international recommendation. In addition, most of the GDT range are UL listed.



Gas Discharge Tube Selector

		CITEL Part Number	DC sparkover voltage (100V/s)	Impulse sparkover voltage (1kV/s)	Insulation resistance (at 100Vdc)	Capacitance	Holdover voltage (P = 500, 0.1s impulse; P = 100, 1.10s in parallel)	AC Discharge current (50Hz, 10.5 times)	Nominal discharge current (8/20µs, 1 time)	Nominal discharge current (8/20µs, 0 times)	Mechanical
2 - ELECTRODE	BA	BA90	72-108 V	≤640 V	≥10G Ω	≤0.3 pF	≥60 V	10 A	25 kA	10 kA	
		BA150	120-180 V	≤700 V	≥10G Ω	≤0.3 pF	≥80 V	10 A	25 kA	10 kA	
		BA230	184-276 V	≤700 V	≥10G Ω	≤0.3 pF	≥80 V	10 A	25 kA	10 kA	
		BA300	240-360 V	≤900 V	≥10G Ω	≤0.3 pF	≥80 V	10 A	25 kA	10 kA	
		BA350	280-420 V	≤900 V	≥10G Ω	≤0.3 pF	≥80 V	10 A	25 kA	10 kA	
		BA550	440-660 V	≤1200 V	≥10G Ω	≤0.3 pF	≥80 V	10 A	25 kA	10 kA	
	BB	BB75	60-90 V	≤640 V	≥10G Ω	≤0.8 pF	≥60 V	10 A	25 kA	10 kA	
		BB90	72-108 V	≤640 V	≥10G Ω	≤0.8 pF	≥60 V	10 A	25 kA	10 kA	
		BB150	120-180 V	≤640 V	≥10G Ω	≤0.8 pF	≥75 V	10 A	25 kA	10 kA	
		BB230	184-276 V	≤700 V	≥10G Ω	≤0.8 pF	≥80 V	10 A	25 kA	10 kA	
BB350		280-420 V	≤850 V	≥10G Ω	≤0.8 pF	≥80 V	10 A	25 kA	10 kA		
BH	BB500	400-600 V	≤1200 V	≥10G Ω	≤0.8 pF	≥80 V	10 A	25 kA	10 kA		
	BH75	60-90 V	≤640 V	≥10G Ω	≤0.8 pF	≥60 V	15 A	30 kA	15 kA		
	BH90	72-108 V	≤640 V	≥10G Ω	≤0.8 pF	≥60 V	20 A	40 kA	20 kA		
	BH230	184-276 V	≤700 V	≥10G Ω	≤0.8 pF	≥80 V	20 A	40 kA	20 kA		
	BH350	280-420 V	≤850 V	≥10G Ω	≤0.8 pF	≥80 V	20 A	40 kA	20 kA		
	BH470	376-564 V	≤1100 V	≥10G Ω	≤0.8 pF	≥80 V	20 A	40 kA	20 kA		
	BH500	400-600 V	≤1200 V	≥10G Ω	≤0.8 pF	≥80 V	20 A	40 kA	20 kA		
	BH600	480-720 V	≤1200 V	≥10G Ω	≤0.8 pF	≥80 V	20 A	40 kA	20 kA		
	BH800	640-960 V	≤1400 V	≥10G Ω	≤0.8 pF	≥80 V	10 A	25 kA	10 kA		
	BH1400	1120-1680 V	≤2000 V	≥10G Ω	≤0.8 pF	≥120 V	10 A	25 kA	10 kA		
3 - ELECTRODE	BT	BH2500	2000-3000 V	≤3800 V	≥10G Ω	≤0.8 pF	≥120 V	10 A	25 kA	10 kA	
		BH3500	2800-4200 V	≤4600 V	≥10G Ω	≤0.8 pF	≥120 V	10 A	25 kA	10 kA	
		BT90	72-108 V	≤640 V	≥10G Ω	≤0.9 pF	≥70 V	20 A	25 kA	20 kA	
		BT150	120-180 V	≤640 V	≥10G Ω	≤0.9 pF	≥80 V	20 A	25 kA	20 kA	
		BT230	184-276 V	≤750 V	≥10G Ω	≤0.9 pF	≥80 V	20 A	25 kA	20 kA	
BM	BT350	280-420 V	≤900 V	≥10G Ω	≤0.9 pF	≥80 V	20 A	25 kA	20 kA		
	BT500	400-600 V	≤1100 V	≥10G Ω	≤0.9 pF	≥80 V	20 A	25 kA	20 kA		
	BM90	72-108 V	≤640 V	≥10G Ω	≤0.5 pF	≥60 V	10A	25 kA	10 kA		
	BM150	120-180 V	≤700 V	≥10G Ω	≤0.5 pF	≥80 V	10A	25 kA	10 kA		
	BM230	184-276 V	< 800 V	≥10G Ω	≤0.5 pF	≥80 V	10A	25 kA	10 kA		
	BM350	280-420 V	≤1000 V	≥10G Ω	≤0.5 pF	≥80 V	10A	25 kA	10 kA		
	BM500	400-600 V	≤1200 V	≥10G Ω	≤0.5 pF	≥80 V	10A	25 kA	10 kA		
GSG IEC 61643	BG	BG600	480-720 V	≤1500 V	>255 Vrms	≥10G Ω	60 kA	100 kA	>15 kA		
		BG-800	640-960 V	≤1500 V	>255 Vrms	≥10G Ω	60 kA	100 kA	>15 kA		
		BG-1000	800-1200 V	≤1800 V	>255 Vrms	≥10G Ω	60 kA	100 kA	>15 kA		
		BG-1300	1040-1560 V	≤2000 V	>255 Vrms	≥10G Ω	60 kA	100 kA	>15 kA		
		BF-800	640-960 V	≤1500 V	>255 Vrms	≥10G Ω	80 kA	140 kA	>40 kA		

* All tests are ITU-T K.12 compliant
 ** Other voltages available upon request. Packing available in boxed or taped & reel.



Notes





France Head Office

CITEL-2CP

2 rue Troyon
92316 Sèvres CEDEX
France
Tél. : +33 1 41 23 50 23
Fax : +33 1 41 23 50 09
e-mail : contact@citel2cp.com
Web : www.citel2cp.com

Germany

CITEL Electronics GmbH

Alleestrasse 144, Tor 5
D-44793 Bochum
Germany
Tel. : +49 234 54 72 10
Fax : +49 234 54 72 199
e-mail : info@citel.de
Web : www.citel.de

China

Shanghai Citel Electronics Co, Ltd

521, Kang Hua Road
Kang Qiao Industrial Zone
201315 Pudong, Shanghai
P.R. CHINA
Tel. : +86 21 58 12 25 25
Fax : +86 21 58 12 21 21
e-mail : shanghai@citel2cp.com
Web : www.citel.cn

USA

CITEL Inc.

11381 Interchange Circle South -
Miramar FL33025
USA
Toll free : +1 800 248 3548
Tel. : +1 954 430 6310
Fax : +1 954 430 7785
e-mail : citel@citel.us
Web : www.citel.us

Czech Republic

CITEL ELECTRONICS

Kundratka 17A
18000 Praha
Czech Republic
Tel. : +420 284840-395
Fax : + 420 284840-195
e-mail : hlavacek@citel.cz
Web : www.citel.cz

Russia & CIS

CITEL RUSSIA

Bolshaya Pochtovaya 26V, Str.1
105082, Moscow
Russia
Tel./Fax : +7 495 669 3270
e-mail : info@citel.ru
Web : www.citel.ru

Distributor: