

Autosport

Second Edition

Technical Manual

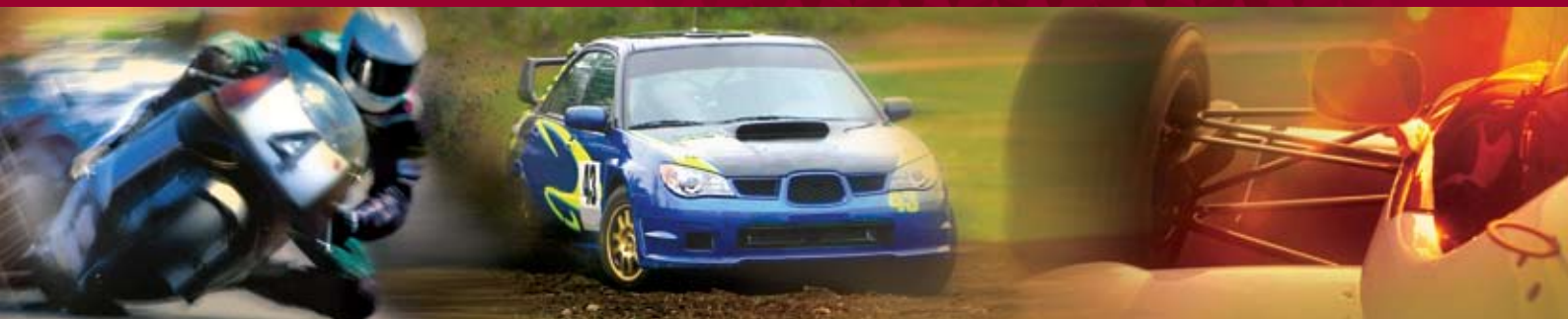

DEUTSCH

AUTOSPORT

Autosport *Technical Manual*



Through our dedicated Autosport team, Deutsch UK provide the customer with specific technical assistance. This service is supported by an extensive testing facility located at our UK site in Hastings, where our entire range of Autosport products are manufactured. We have at our disposal all the necessary engineering resource and experience with which to recommend the best technical solutions.

Driven by our desire to provide maximum support to the industry, this manual has been written in response to customers' most commonly asked questions.

The purpose of the manual is to enable the customer to obtain the best possible performance from Deutsch Autosport products in order to meet the ever-increasing demands on electrical systems within the Autosport industry.

This manual is only intended as a guide to assist the customer in the use of our products. Our dedicated Autosport team is always available to provide technical assistance and support. Contact information for our offices worldwide can be found on the reverse of this manual.



CONTENTS

4	Best Practices	10	Filler Plugs & Vibration Information
5	Wire Preparation	11	Printed Circuit Board (PCB) Layout Information
6	Crimping	22	Glossary of Terms
7	Acceptance Criteria / Voltage Drop Test	24	AWG / Metric Conductor Chart
8	Contact Insertion / Extraction	26	Reference Guide
9	Contact Retention Test		



All you need for successful connector use. Crimp tool, positioners, wire cutter and wire stripper.

1. Do not use scalpels or knives to strip wire insulation, unless instructed to do so.
2. Ensure wire strip does not damage the conductor strands.
3. The strip length must allow full depth location in the crimp bucket.
4. The strip length must not expose too much wire.
5. Do not pinch or twist the exposed wire strands.
6. All wire strands must be located in the crimp bucket.
7. Check the crimp settings on the crimp tool 'positioner' for the correct wire size.
8. The crimp tool should be calibrated periodically, dependant on use.
9. The crimp tool operation must fully close before release to ensure a full crimp.
10. Contacts must only be crimped once.
11. Always use an insertion/extraction tool that is in good condition.
12. Use lubrication (e.g. IPA see page 8) to aid with contact insertion/extraction and prevent damage to the rubber.
13. Do not use excessive force to locate the contact.
14. The insertion/extraction tool is designed to buckle under excessive load. Continued use will cause damage to the tool and connector.
15. Do not use 'spare' insertion/extraction tools unless correctly identified.
16. Do not rotate insertion/extraction tools in the connector. This will damage retention tines.
17. Always use a contact in a cavity even when unwired. This maintains the sealing integrity.
18. Always use filler plugs in unwired cavities to maintain sealing integrity.
19. Always use a contact and filler plug together.
20. Always place the head of the filler plug in the cavity for support (see page 10).
21. Do not use metal insertion/extraction tools.
22. If necessary, check contact location using contact retention test tools (see page 9).

A fundamental aspect of preparing a good crimp is the work required prior to the removal of the connector from its bag. The wire must be prepared correctly in order to ensure that the crimp is as secure and efficient as possible.

The first action that must be taken is to cut the wire to the required length. The wire-cutting tool must be sharp enough to create a clean, square cut (i.e. 90 degrees across the wire). If the wire is not cut square, this will leave strands of the conductor at different lengths. If a crimp is attempted with the wire in this condition, not all of the conductor strands will be inserted into the crimp bucket of the contact to a sufficient depth. This could potentially weaken the final crimp.



Not the best way to strip insulation. Pliers may remove the insulation, but are also likely to break and remove strands of the wire too.

When the wire has been cut correctly, the next step is to strip the insulation. In order to carry out this task correctly, a professional wire-stripping tool is required. There are several on the market, but as is the case with any tool used in harness work, a higher quality tool will result in a higher quality final product.

We recommend a tool with wire gauges that also employs a mechanical action to strip the insulation. Stripping tools that rely on manual strength to strip the insulation can often result in damage to the wire, with one or more of the conductor strands being removed, which is undesirable.



Wire stripping with a recommended tool will allow the insulation to be removed accurately without damaging the wires.



An example of a good crimp showing the exposed wire.

There is a degree of flexibility regarding the length of strip required. As a guide, the final product should allow a small (1mm) length of exposed conductor visible from the back end of the contact when the wire is FULLY inserted into the crimp bucket. This will allow movement of the wire without damaging the crimp. If the insulation is cut too close to the back end of the contact, this could subject the crimp to extra stress.

When the insulation has been removed NEVER twist the strands of wire. Doing so changes the diameter of the wire which may mean it cannot easily enter the contact bucket.

This practice also causes different strands to be under different stress levels, thus the crimp will never have an equal finish.

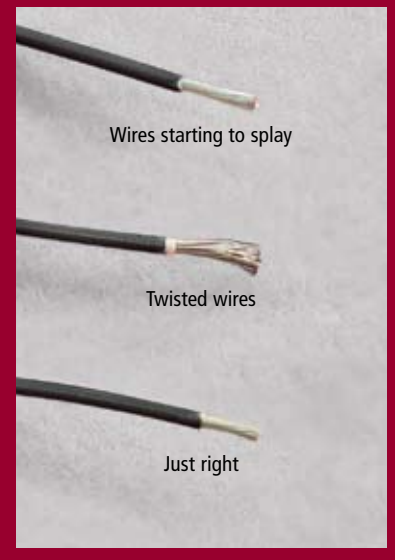

SUGGESTED WIRE STRIP LENGTHS

Exact lengths for wire strips should be included in each harness house's formal technical procedures, but as a general recommendation, no more than 1mm of the conductor should be left exposed after crimping. If after a 'test insertion' is carried out, more of the conductor is left exposed than is required, then more of the conductor can be trimmed from the end of the wire. Again, a sharp wire-cutting tool should be used in order to ensure that the cut is clean and square.

CONTACT TYPE	SUGGESTED WIRE STRIP LENGTH
ASU #24	3.8 - 4.8mm
ASU #22	3.8 - 4.8mm
ASL	3.0 - 4.0mm
ASC	3.8 - 4.8mm
AS MINI #22	3.8 - 4.8mm
AS MINI #20	5.6 - 6.6mm
ASDD 9-WAY #24	3.8 - 4.8mm
ASDD #24	3.8 - 4.8mm
AS #22	3.8 - 4.8mm
AS #20	5.6 - 6.6mm
AS #16	5.6 - 6.6mm
ASHD	15.0 - 16.0mm

The single most important aspect of connector best practice is the crimp. The crimp process for Deutsch Autosport connectors employs identical technology to that of the MIL-C-39029 military standard. Selecting the correct crimp tool and positioner for the required contact is vital. See reference chart for contacts on page 26.

Two crimp tools and a variety of crimp positioners are the only equipment required for the entire range of Deutsch Autosport contacts with the exception of ASHD, for which special tooling is required.



THE CRIMPING CONCEPT

The term 'crimping' refers to a method of firmly attaching a terminal or contact to the end of an electrical conductor by pressure forming or reshaping a metal barrel onto the connector. The forming of a satisfactory crimp is dependant upon the correct combination of conductor, crimp barrel and crimping tool.

When the correct combination of equipment is employed, a crimp that has both good electrical

and mechanical characteristics will be formed. Reliability of tooling and repeatability of the crimp can be ensured by using the recommended gauges to check the tools. These should be regularly calibrated.

The electrical resistance of a correctly designed and controlled crimp joint should be equal to, or less than that of an equal section of wire. The requirements regarding millivolt drop at

a designated current can be found on page 7 of this manual.

The mechanical strength of a crimped joint and hence its pull-off force (tensile strength) can vary according to the deformation applied. Therefore, a properly deformed crimp will result in a high pull-off force. In summary, the crimp die of the tool directly determines the crimp configuration and deformation.



Example of a poor crimp showing deformation of the inspection hole against a correct example. This is caused by incorrect tool settings.



A good crimp showing the individual wires compressed evenly.

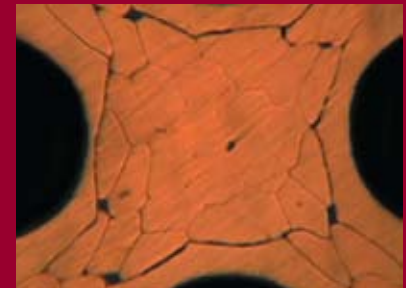

A poor, over compressed crimp showing the wires being forced unevenly and leaving fractures in the contact bucket.

VISUAL INSPECTION

During visual inspection the following acceptance criteria should apply:

1. The wire insulation should not have been damaged during the crimping process.
2. The conductor should be visible in the inspection hole of the contact.
3. The crimp barrel should have no sharp edges, cracked plating or cuts after the crimping process.
4. Tarnished or corroded contacts that were overlooked in the pre-assembly inspection should be cause for rejection.
5. Wrongly positioned crimps, as determined by marks found on areas where no crimp deformation should be found, should be cause for rejection.
6. Under-crimping (indicated by loose conductor) or over-crimping (indicated by broken conductor strands or deformation of the conductor at the end of the terminal) should be cause to stop work. All production crimps made since the last inspection or pull test should then be rejected. Tool settings, wire size and contacts should be inspected to determine the cause of crimp failure.
7. No attempt should be made to straighten bent contacts.

CONNECTOR BARREL WIRE CRIMPING

1. The required axial strength should be a minimum of 75% of the wire strength.
2. The bottom right table details the minimum requirements for axial strength for copper and copper alloy wire; with either silver, tin or nickel-plated finishes.

VOLTAGE DROP TEST

The voltage drop should be measured from a point on the positioning shoulder of the contact to another point 14mm distant on the attached wire. The voltage drop of the contact crimp joint should not exceed the value specified for each wire tested.

WIRE BARREL	WIRE SIZE (AWG)	TEST CURRENT	MAX. VOLTAGE DROP (MV)
			SILVER OR TIN PLATED COPPER WIRE
12	12	23	3.0
	14	17	3.5
16	16	13	3.5
	18	9.0	4.0
20	20	7.5	4.0
	22	5.0	4.0
	24	3.0	4.0
22	22	5.0	4.0
	24	3.0	4.0
24	26	2.0	4.0
	24	3.0	4.0
	26	2.0	4.0
26	28	1.5	5.0
	26	2.0	4.0
28	28	1.5	5.0
	30	1.5	5.0

TENSILE STRENGTH

The crimped contact-wire assemblies should be placed in a tensile testing device whose calibration is accurate to + 0.2 N, and an axial load applied at the rate of 25mm/min ± 6.5mm/min.

The connections should be loaded until failure occurs. The value at failure should be recorded, together with the information as to whether the failure was 'pull-out', 'broke-in-crimp' or 'break-in-wire'. The required minimum axial strengths for crimped joints are shown in the table below.

WIRE BARREL	WIRE SIZE (AWG)	AXIAL STRENGTH (NEWTON)	
		Silver or Tin Plated Copper Wire	Copper Alloy Wire
12	12	500	-
	14	320	-
16	16	230	-
	18	155	-
20	20	90	-
	20	90	185
	22	60	115
22	24	40	60
	22	60	115
24	24	40	60
	26	-	45
	24	40	60
26	26	-	45
	28	-	30
28	26	-	45
	28	-	30
30	28	-	30
	30	-	30

Required ultimate axial strength for compactive and dispersive crimped joints.





A variety of insertion/extraction tools used on Autosport Connector Ranges.

CONTACT INSERTION / EXTRACTION TOOLS

All Deutsch Autosport connectors are supplied with the relevant insertion/extraction tool. It is essential that the correct, undamaged tool is used when inserting contacts into the connector. The tools are manufactured from a flexible plastic that will bend before causing any damage to the rear rubber of the connector.

Different specifications of military style connectors can have different characteristics and properties. For example, a MIL-C-26482 series connector has different diameters and tolerances inside the contact cavity to those inside an Autosport connector. Therefore, in order to avoid damage to the Autosport connector, it is advisable to only use the insertion/extraction tool that was supplied with it.

It is recommended that a new tool is used for each connector. If a tool has become worn or if it has been rotated during the insertion of a contact, then parts of the tool can break off inside the contact cavity. This can permanently damage the retention tines and render the connector useless.

ISO PROPYL ALCOHOL - IPA

Through extensive testing, Deutsch UK have discovered a number of processes that improve the assembly, installation and operation of Autosport connectors.

As a result of these tests, Deutsch UK have identified a lubricant; Propan-2-ol (ISO Propyl Alcohol - IPA), which significantly aids contact insertion through the high integrity rear seal of the connector with greatly reduced effort. IPA will rapidly evaporate and leave no residue in the connector.

It is recommended that all contacts and insertion tools are dipped in a small pot (20ml maximum) or safety container of IPA prior to contact insertion. Extraction tools should also be immersed in IPA prior to use. To prevent contamination only clean IPA should be used.

Regarding safety, the volumes of IPA being used should not cause a problem. However, it is recommended that users of IPA should refer to the relevant 'Health and Safety' and 'COSHH' data sheets. IPA is not warranted by Deutsch UK for use on any other connector or any other manufacturer's connector unless otherwise specified.

1 CONTACT INSERTION



After a successful crimp, the contact can now be inserted into the connector. Using the insert/extraction tool provided, slide the wire, using your thumb, so that the wire is enclosed by the tool.

2



This image shows the wire successfully held in the tool.

3

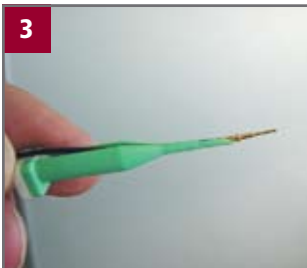

After gently pulling the wire through the tool, the contact will now be in position at the end of the tool. The contact should fit securely and the wire should not have any slack.

4



This image shows detail of the tines inside the connector. The process of inserting a contact into the connector will slide the contact into position, allowing the shoulder to pass beyond the tines, which will lock into position behind the shoulder. The insertion end of the tool is moulded at an angle to ease the contact into position. The extraction end of the tool is moulded with a straight end to 'unlock' the tines and allow contact removal.

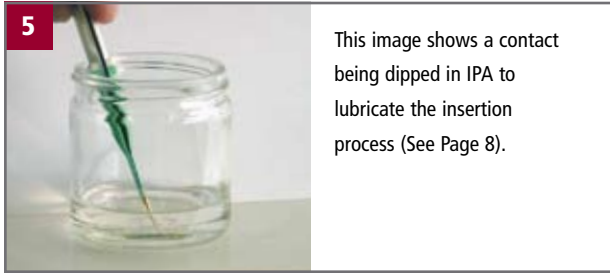

5 This image shows a contact being dipped in IPA to lubricate the insertion process (See Page 8).

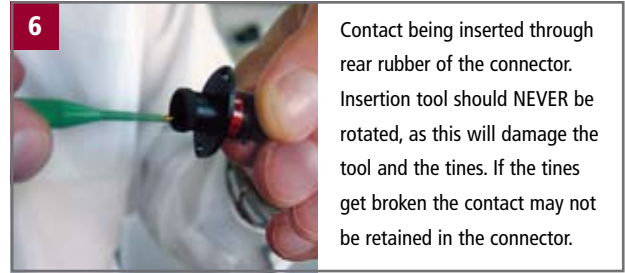

6 Contact being inserted through rear rubber of the connector. Insertion tool should NEVER be rotated, as this will damage the tool and the tines. If the tines get broken the contact may not be retained in the connector.



7 Once the tool has been fully inserted in the back of the connector. There will be a discernable 'click' as the shoulder of the contact passes through the tines and locks into position. The tool can then be removed leaving the contact locked into position.

It is recommended either to use a contact retention test tool or give the wire a small tug to ensure the contact is installed correctly.



8 CONTACT EXTRACTION
To remove a correctly installed contact, the other end of the tool is used. The extraction end of the tool has a flat aspect to enable all the tines to be unlocked together. The extraction end of the tool is inserted into the rear of the connector until the tines can be felt to unlock. Again, IPA can be used to lubricate the tool. A thumb should then be placed on the wire gripping the wire to the tool. The contact and wire can then be pulled from the back of the connector and a proper extraction can occur.

CONTACT RETENTION TEST

The contact retention test is one of the most important quality assurance procedures. This test checks that pin and socket contacts are correctly seated in the connector by exerting a pre-determined amount of force on the front of each contact to ensure that it will not be pushed out of the back of the connector.



CONTACT RETENTION TEST TOOLS

Contact retention test tools are designed with replaceable aluminium tester pin or socket tips. These tools enable the user to perform the test quickly and easily. The chart below shows the part numbers for the contact retention tools that are available. All the tools come with both Pin and Socket tester heads.

CONTACT SIZE/TYPE	COMPLETE TOOL NO	REPLACEMENT SOCKET PROBE	REPLACEMENT PIN PROBE
Size 24 (ASDD excluding 9-way)	HT270-24A	67-024-01S	68-024-01L
Size 24 & 23 (ASDD 9-way and ASU 5-way)	HT270-24B	67-024-01S	68-024-01LS
Size 22 (ASU/ASC)	HT270-22B	67-022-01	68-022-01LS
Size 22 (STD 8-24)	HT270-22A	67-022-01	68-022-01L
Size 20	HT270-20	67-020-01	68-020-01
Size 16	HT270-16	67-016-01	68-016-01

PROCEDURE

1. With the connector held stationary, mate the test tip of the contact retention tool with the contact.
2. Apply a preset force to the contact (see table below).
3. When the body of the tool reaches the indicator band, the required retention force has been achieved.
4. Repeat this process until each contact has been tested.

CONTACT SIZE	MAX. ENGAGEMENT FORCE (MIL-C-39029) LBS.F (N) PER CONTACT.	MINIMUM CONTACT RETENTION FORCE (MIL-DTL-38999) LBS.F (N)	SUGGESTED LOCATION FORCE LBS.F (N)
#22/#23/#24	0.6 (2.6)	10 (44)	3 (13)
#20	0.75 (3.3)	15 (67)	5 (22)
#16	1.5 (6.6)	25 (111)	8 (35)
#12	1.5 (6.6)	25 (111)	8 (35)
#10	3.75 (16)	25 (111)	8 (35)
#8	10 (45)	25 (111)	8 (35)

Please note:

The preset type tool is very precise in its adjustment and therefore needs to be tested carefully itself (preferably calibrated) before use. The tools are to be used as a simple indicator to verify contact locking. Therefore, Deutsch recommend that these tools are set to a figure no greater than 30% of the specification stated value.

The table above shows the forces detailed in the relevant specifications for testing the contacts and inserts for qualification approval and maintenance testing. These figures are specified to ensure the minimum reliable performance levels and therefore must only be used when the correct equipment and tooling are used.

The contact retention test tools available from Glenair are not designed to meet this requirement. They are designed to ensure that a wireman or operator has adequately located the contact and as such not to stress the cavity in which the contact is located.

The table above also lists a suggested location force. The suggested test figures are based on approximately 30% of the minimum contact retention force. The figures are significantly greater than the maximum engagement force up to #10 where manual loads become impractical. The suggested forces ensure that the contact cannot be dislodged during connector mating and unmating but allow manual testing without excessive loads.

FILLER PLUGS

Filler plugs are designed to ensure the sealing capabilities of the connector are not affected when a cavity is left unwired. The following procedure should be used to ensure that the filler plug is properly secured in the contact cavity, optimum sealing is maintained and no damage can be caused to the connector, thereby affecting sealing.

PROCEDURE

- 1. In an unwired cavity a contact must be inserted before inserting a filler plug. This is to ensure the front face sealing integrity is maintained. The contact supports the seal, ensuring it is under compression when the connector is mated.**
- 2. The filler plug must be inserted head first into the rear of the connector. The head fits snugly in the contact cavity ensuring that the filler plug cannot be vibrated out of the connector and that lateral movement is minimised.**

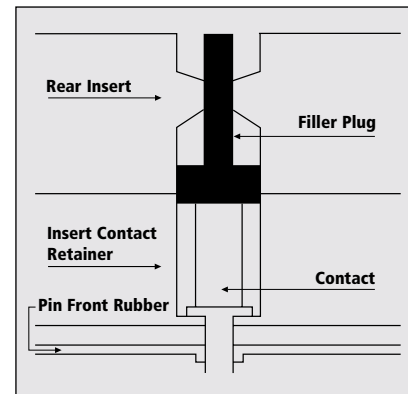

VIBRATION INFORMATION

All Deutsch Autosport connectors have been subject to a rigorous test regime to ensure durability during service. This includes vibration testing designed to replicate race conditions.

All Autosport connector designs are subjected to three tests:

- **Dynamic**
- **Endurance**
- **Sinusoidal Resonance.**

THE DYNAMIC TEST

A random on random vibration that test simulates the normal vibration created by engine, gearbox and suspension movement. The test operates at 6g²/Hz, with spikes to 11g²/Hz (over 60g RMS). Injected onto this base line are further spikes of vibration, which simulate kerb and potholes.

THE ENDURANCE TEST

Consists of random vibration peaking at 57g RMS for 8 hours in each axis.

THE SINUSOIDAL RESONANCE TEST

Ramps to over 75g between 350 and 2000 Hz ensuring there are no self-destructive elements within the connector.

The connector pairs are fully wired and monitored for electrical function during all of these tests. There must be no sign of damage that would impair electrical or mechanical connector performance.

Graph depicting a typical test with random vibration being injected with spikes of narrow band vibration added to the test procedure.

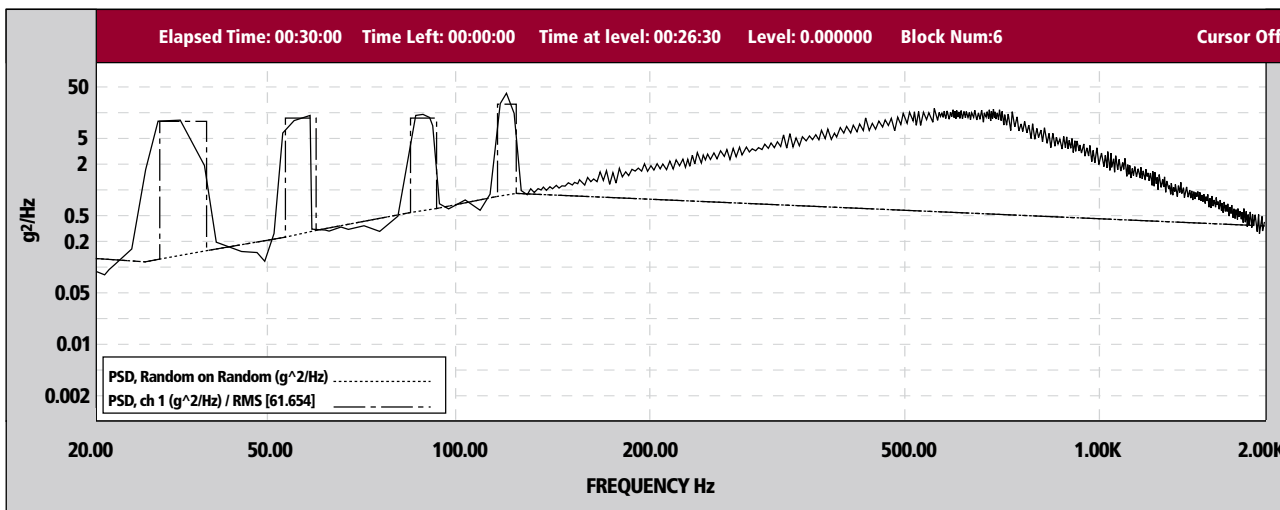

The graph above displays measurements from an actual random on random test. It shows the energy input in g²/Hz over the frequency range from 20 to 2000 Hz and the four spikes of low frequency, high-energy simulating road faults.

ANTI-VIBRATION

Vibration characteristics will vary with the environment. These variations should be accounted for as part of the vehicle design. However, certain elements should be considered in all situations. The way in which the connector is mounted is critical. Where possible, the use of anti-vibration mounts is recommended. Anti-vibration mounts should always be used to mount connectors in areas of high vibration such as the gearbox.

Anti-vibration mounts should always be mounted firmly and any mounting brackets must be robust enough to prevent any occurrence of secondary vibration. Many factors can affect vibration characteristics in any given situation and the Deutsch Autosport team will be happy to offer advice on any problems encountered.

Printed Circuit Board (PCB) Layout Information



This section details exact contact location information for designers of Printed Circuit Board (PCB) solutions. The drawings and associated matrices designate the locations of each contact from an X and Y reference plane. Each standard Autosport planoform is detailed.

For more information and ordering details please call our sales office on +44 (0) 1424 852722 or email autosport@deutsch.net

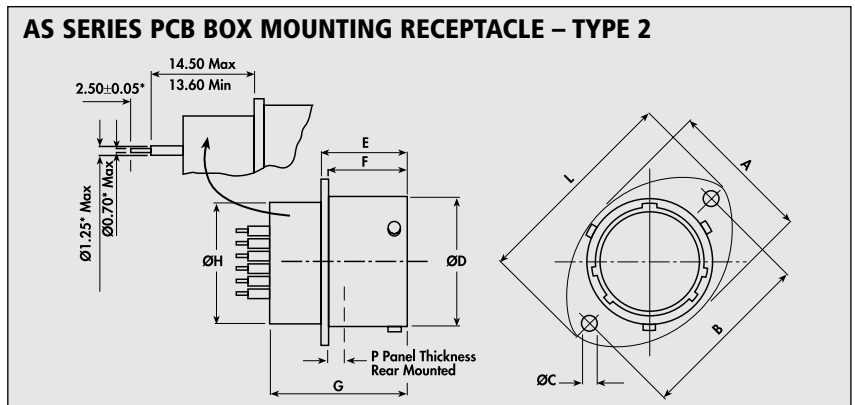
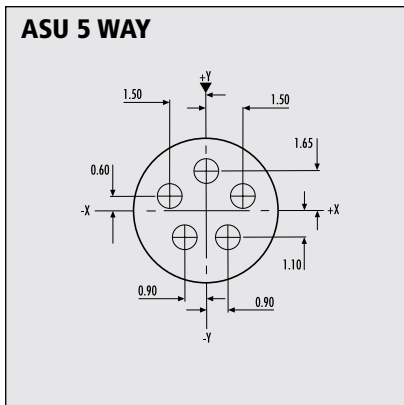
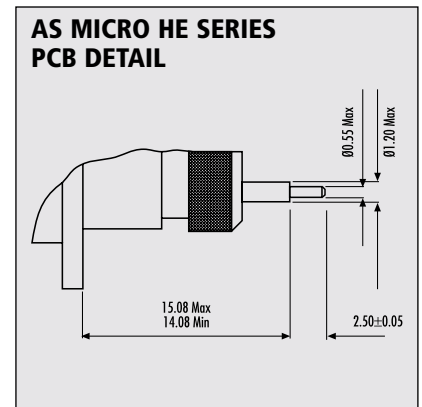
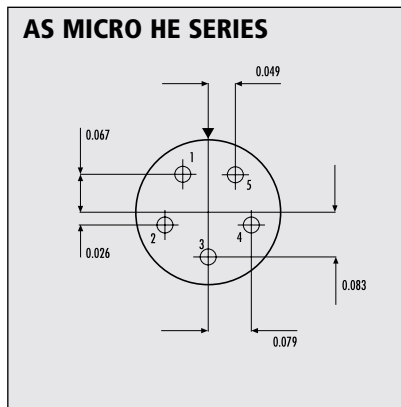
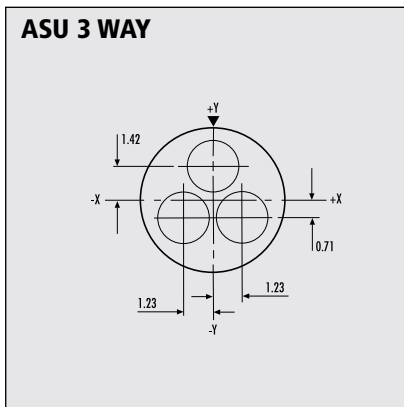

*Dimensions for 20 and 22 contacts shown are for standard parts. Other PCB contacts are available.

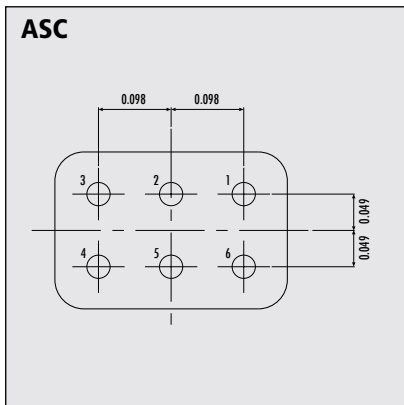

SHELL SIZE	A	B	C	D	E	F	G	H	L	P
Ref	± 0.2	+ 0.1 - 0	+ 0 - 0.13	+ 0.15 - 0	+ 0 - 0.13	MAX	MAX	MAX	MAX	MAX
08	16.50	21.40		12.00				11.10	27.20	
10	19.50	25.90		15.00				14.27	32.00	
12	24.00	29.10		19.05				17.44	35.20	
14	27.00	32.50	3.2	22.22	17.21	16.05	27.65	20.60	38.40	3.00
16	30.30	34.80		25.40				23.77	41.00	
18	33.70	38.20		28.57				26.94	44.70	
20	37.00	41.60		31.75				30.11	47.90	
22	40.00	44.95		34.92		15.29		33.29	51.10	
24	43.30	49.35	3.7	38.10				36.46	55.80	2.26

Contact Location 8-98, 8-35, 10-98, 10-35, 12-04, 12-98, 12-35

Note: Dimensions relate to the front pin face view. All dimensions are in inches. As per MIL-SPEC-1560A

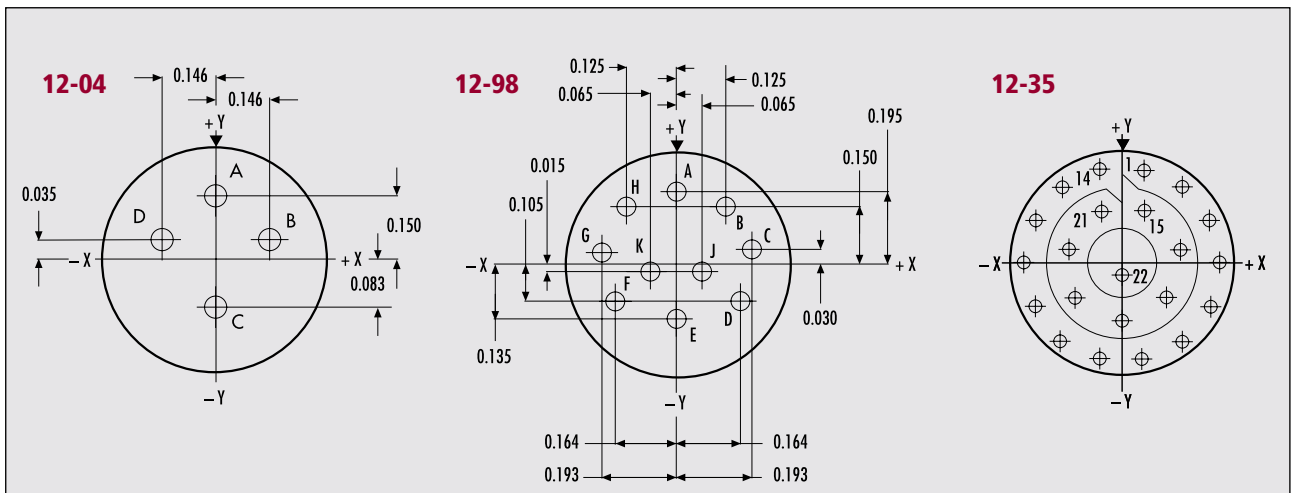
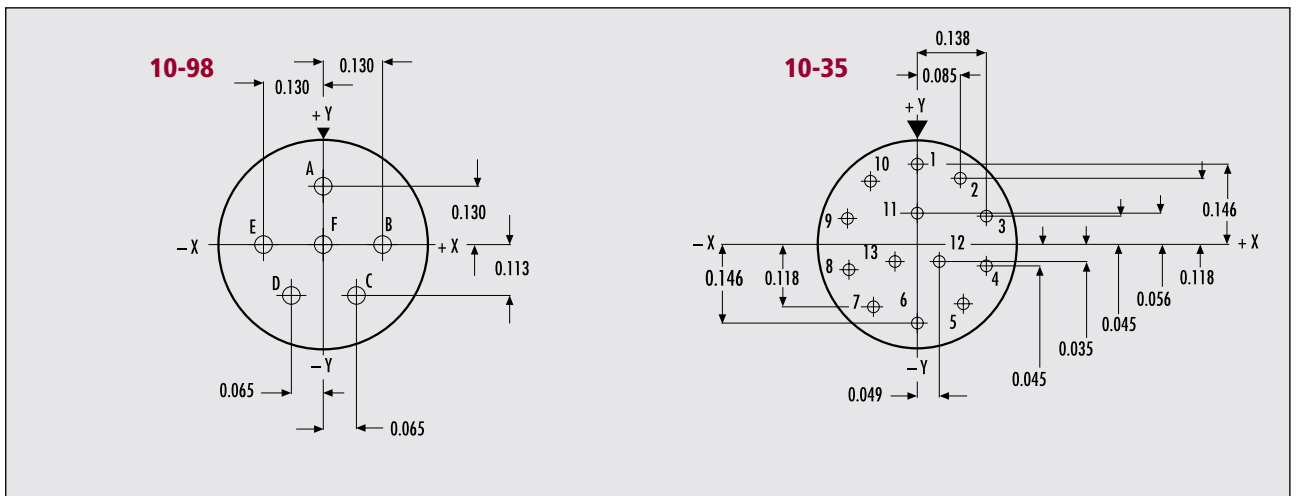
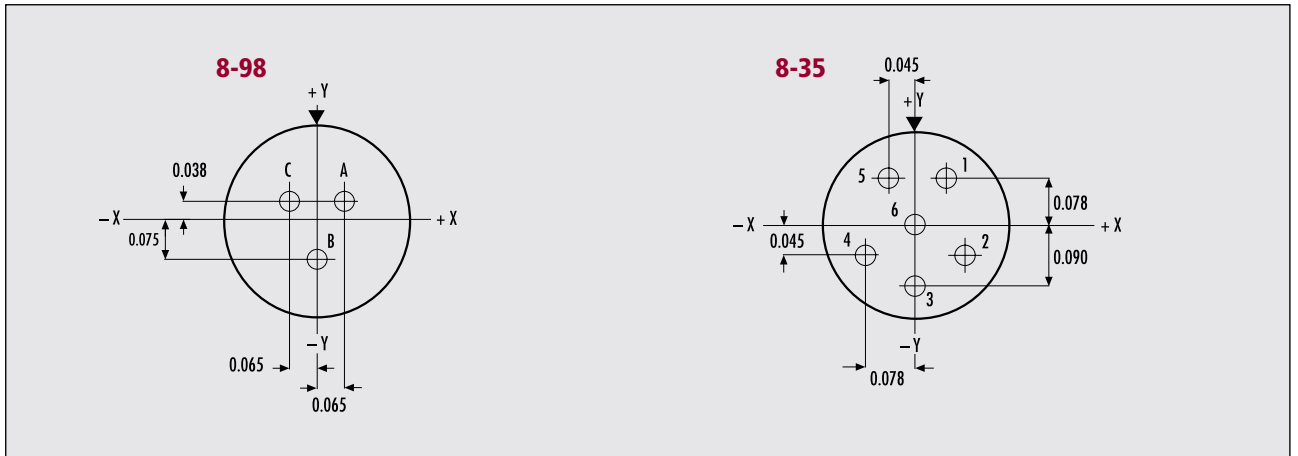

CONTACT LOCATION 12-35

CONTACT NO.	X AXIS	Y AXIS	CONTACT NO.	X AXIS	Y AXIS	CONTACT NO.	X AXIS	Y AXIS	CONTACT NO.	X AXIS	Y AXIS
1	+0.045	+0.197	7	+0.045	-0.197	13	-0.126	+0.158	19	-0.093	-0.075
2	+0.126	+0.158	8	-0.045	-0.197	14	-0.045	+0.197	20	-0.117	+0.026
3	+0.182	+0.088	9	-0.126	-0.158	15	+0.045	+0.107	21	-0.045	+0.107
4	+0.203	0.000	10	-0.182	-0.088	16	+0.117	+0.026	22	0.000	-0.030
5	+0.182	-0.088	11	-0.203	0.000	17	+0.093	-0.075			
6	+0.126	-0.158	12	-0.182	+0.088	18	0.000	-0.120			

Contact Location 14-97, 14-19 & 14-35

Note: Dimensions relate to the front pin face view. All dimensions are in inches. As per MIL-SPEC-1560A

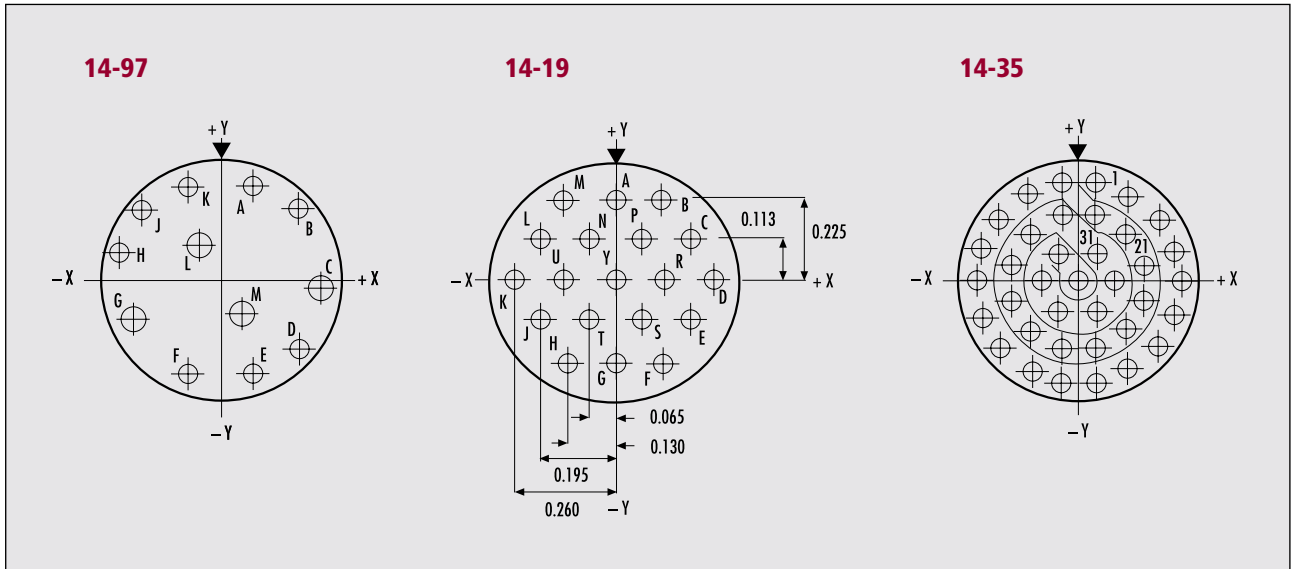

CONTACT LOCATION 14-97

CONTACT NO.	X AXIS	Y AXIS	CONTACT NO.	X AXIS	Y AXIS
A	+0.065	+0.234	G	-0.207	-0.095
B	+0.178	+0.178	H	-0.234	+0.065
C	+0.230	-0.023	J	-0.178	+0.178
D	+0.178	-0.178	K	-0.065	+0.234
E	+0.065	-0.234	L	-0.047	+0.081
F	-0.089	-0.235	M	+0.047	-0.081

CONTACT LOCATION 14-35

CONTACT NO.	X AXIS	Y AXIS	CONTACT NO.	X AXIS	Y AXIS	CONTACT NO.	X AXIS	Y AXIS	CONTACT NO.	X AXIS	Y AXIS
1	+0.045	+0.262	11	-0.130	-0.232	21	+0.170	+0.040	31	+0.045	+0.074
2	+0.123	+0.217	12	-0.200	-0.175	22	+0.170	-0.050	32	+0.090	-0.004
3	+0.211	+0.160	13	-0.247	-0.098	23	+0.123	-0.127	33	+0.045	-0.082
4	+0.254	+0.080	14	-0.266	-0.010	24	+0.045	-0.172	34	-0.045	-0.082
5	+0.266	-0.010	15	-0.254	+0.080	25	-0.045	-0.172	35	-0.090	-0.004
6	+0.247	-0.098	16	-0.211	+0.160	26	-0.123	-0.127	36	-0.045	+0.074
7	+0.200	-0.175	17	-0.123	+0.217	27	-0.170	-0.050	37	0.000	-0.004
8	+0.130	-0.232	18	-0.045	+0.262	28	-0.170	+0.040			
9	+0.045	-0.262	19	+0.045	+0.172	29	-0.123	+0.119			
10	-0.045	-0.262	20	+0.123	+0.119	30	-0.045	+0.172			

For more information and ordering details please call our sales office on +44 (0) 1424 852722 or email autosport@deutsch.net

Contact Location 16-08, 16-26 & 16-35

Note: Dimensions relate to the front pin face view. All dimensions are in inches. As per MIL-SPEC-1560A

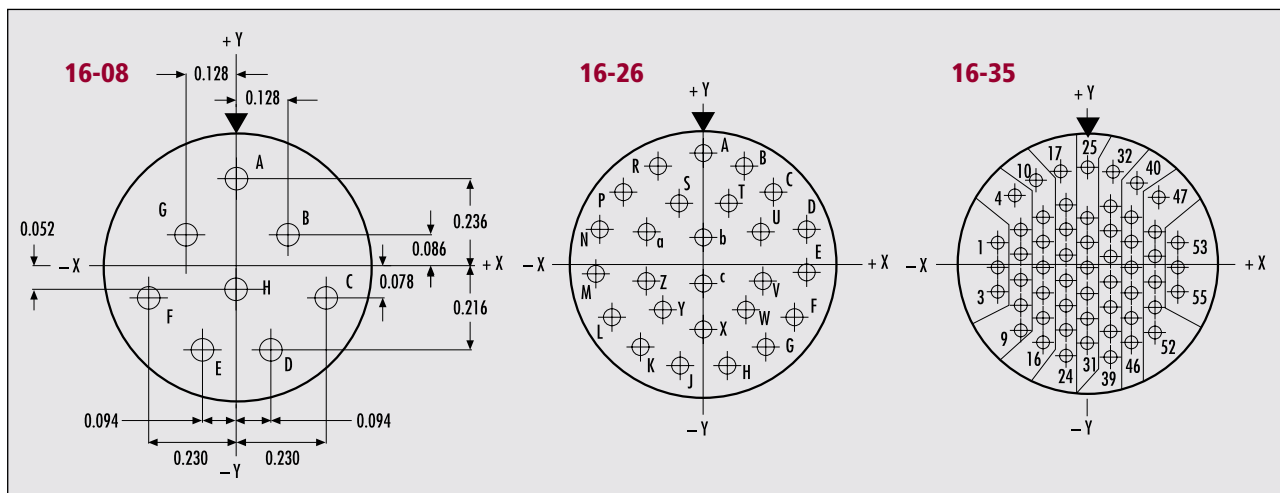

CONTACT LOCATION 16-26

CONTACT NO.	X AXIS	Y AXIS	CONTACT NO.	X AXIS	Y AXIS	CONTACT NO.	X AXIS	Y AXIS	CONTACT NO.	X AXIS	Y AXIS
A	0.000	+0.321	H	+0.067	-0.314	R	-0.131	+0.293	Y	-0.119	-0.151
B	+0.131	+0.293	J	-0.067	-0.314	S	-0.070	+0.177	Z	-0.178	-0.036
C	+0.239	+0.214	K	-0.189	-0.260	T	+0.070	+0.177	a	-0.175	+0.094
D	+0.305	+0.099	L	-0.278	-0.161	U	+0.175	+0.094	b	0.000	+0.065
E	+0.319	-0.034	M	-0.319	-0.034	V	+0.178	-0.036	c	0.000	-0.065
F	+0.278	-0.161	N	-0.305	+0.099	W	+0.119	-0.151			
G	+0.189	-0.260	P	-0.239	+0.214	X	0.000	-0.203			

CONTACT LOCATION 16-35

CONTACT NO.	X AXIS	Y AXIS	CONTACT NO.	X AXIS	Y AXIS	CONTACT NO.	X AXIS	Y AXIS	CONTACT NO.	X AXIS	Y AXIS
1	-0.312	+0.086	15	-0.156	-0.184	29	0.000	-0.094	43	+0.156	-0.004
2	-0.312	-0.004	16	-0.156	-0.274	30	0.000	-0.184	44	+0.156	-0.094
3	-0.312	-0.094	17	-0.089	+0.316	31	0.000	-0.274	45	+0.156	-0.184
4	-0.242	+0.221	18	-0.078	+0.221	32	+0.089	+0.316	46	+0.156	-0.274
5	-0.234	+0.131	19	-0.078	+0.131	33	+0.078	+0.221	47	+0.242	+0.221
6	-0.234	+0.041	20	-0.078	+0.041	34	+0.078	+0.131	48	+0.234	+0.131
7	-0.234	-0.049	21	-0.078	-0.049	35	+0.078	+0.041	49	+0.234	+0.041
8	-0.234	-0.139	22	-0.078	-0.139	36	+0.078	-0.049	50	+0.234	-0.049
9	-0.234	-0.229	23	-0.078	-0.229	37	+0.078	-0.139	51	+0.234	-0.139
10	-0.172	+0.279	24	-0.078	-0.319	38	+0.078	-0.229	52	+0.234	-0.229
11	-0.156	+0.176	25	0.000	+0.329	39	+0.078	-0.319	53	+0.312	+0.086
12	-0.156	+0.086	26	0.000	+0.176	40	+0.172	+0.279	54	+0.312	-0.004
13	-0.156	-0.004	27	0.000	+0.086	41	+0.156	+0.176	55	+0.312	-0.094
14	-0.156	-0.094	28	0.000	-0.004	42	+0.156	+0.086			

Contact Location 18-32 & 18-35

Note: Dimensions relate to the front pin face view. All dimensions are in inches. As per MIL-SPEC-1560A

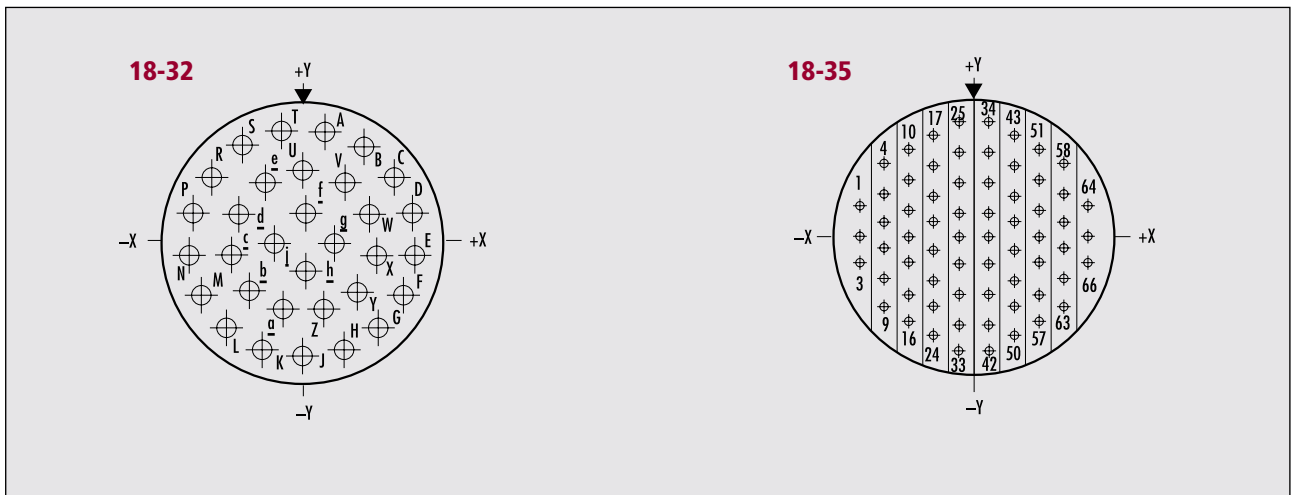

CONTACT LOCATION 18-32

CONTACT NO.	X AXIS	Y AXIS	CONTACT NO.	X AXIS	Y AXIS	CONTACT NO.	X AXIS	Y AXIS	CONTACT NO.	X AXIS	Y AXIS
A	+0.066	+0.353	J	0.000	-0.359	T	-0.066	+0.353	b	-0.174	-0.151
B	+0.189	+0.305	K	-0.130	-0.335	U	0.000	+0.230	c	-0.228	-0.033
C	+0.286	+0.217	L	-0.242	-0.265	V	+0.124	+0.193	d	-0.209	+0.095
D	+0.345	+0.098	M	-0.321	-0.160	W	+0.209	+0.095	e	-0.124	+0.193
E	+0.357	-0.033	N	-0.357	-0.033	X	+0.228	-0.033	f	0.000	+0.096
F	+0.321	-0.160	P	-0.345	+0.098	Y	+0.174	-0.151	g	+0.096	0.000
G	+0.242	-0.265	R	-0.286	+0.217	Z	+0.065	-0.221	h	0.000	-0.096
H	+0.130	-0.335	S	-0.189	+0.305	a	-0.065	-0.221	j	-0.096	0.000

CONTACT LOCATION 18-35

CONTACT NO.	X AXIS	Y AXIS	CONTACT NO.	X AXIS	Y AXIS	CONTACT NO.	X AXIS	Y AXIS	CONTACT NO.	X AXIS	Y AXIS
1	-0.357	+0.090	18	-0.123	+0.225	35	+0.045	+0.270	52	+0.201	+0.180
2	-0.357	0.000	19	-0.123	+0.135	36	+0.045	+0.180	53	+0.201	+0.090
3	-0.357	-0.090	20	-0.123	+0.045	37	+0.045	+0.090	54	+0.201	0.000
4	-0.279	+0.225	21	-0.123	-0.045	38	+0.045	0.000	55	+0.201	-0.090
5	-0.279	+0.135	22	-0.123	-0.135	39	+0.045	-0.090	56	+0.201	-0.180
6	-0.279	+0.045	23	-0.123	-0.225	40	+0.045	-0.180	57	+0.201	-0.270
7	-0.279	-0.045	24	-0.123	-0.315	41	+0.045	-0.270	58	+0.279	+0.225
8	-0.279	-0.135	25	-0.045	+0.360	42	+0.045	-0.360	59	+0.279	+0.135
9	-0.279	-0.225	26	-0.045	+0.270	43	+0.123	+0.315	60	+0.279	+0.045
10	-0.201	+0.270	27	-0.045	+0.180	44	+0.123	+0.225	61	+0.279	-0.045
11	-0.201	+0.180	28	-0.045	+0.090	45	+0.123	+0.135	62	+0.279	-0.135
12	-0.201	+0.090	29	-0.045	0.000	46	+0.123	+0.045	63	+0.279	-0.225
13	-0.201	0.000	30	-0.045	-0.090	47	+0.123	-0.045	64	+0.357	+0.090
14	-0.201	-0.090	31	-0.045	-0.180	48	+0.123	-0.135	65	+0.357	0.000
15	-0.201	-0.180	32	-0.045	-0.270	49	+0.123	-0.225	66	+0.357	-0.090
16	-0.201	-0.270	33	-0.045	-0.360	50	+0.123	-0.315			
17	-0.123	+0.315	34	+0.045	+0.360	51	+0.201	+0.270			

For more information and ordering details please call our sales office on +44 (0) 1424 852722 or email autosport@deutsch.net

Contact Location 20-16 & 20-35

Note: Dimensions relate to the front pin face view. All dimensions are in inches. As per MIL-SPEC-1560A

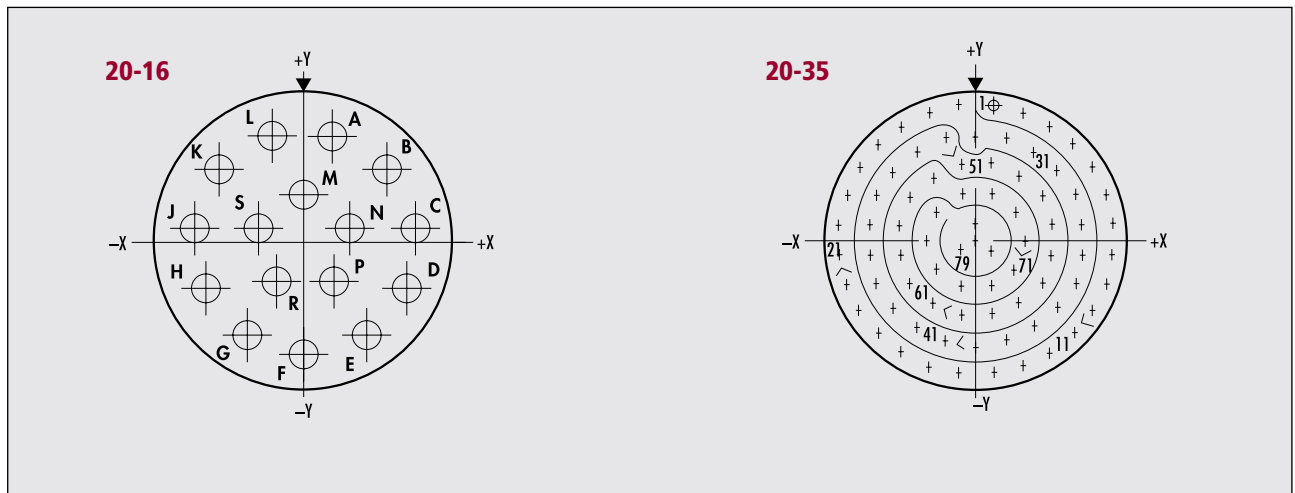

CONTACT LOCATION 20-16

CONTACT NO.	X AXIS	Y AXIS	CONTACT NO.	X AXIS	Y AXIS
A	+0.118	+0.322	J	-0.341	+0.036
B	+0.271	+0.211	K	-0.271	+0.211
C	+0.341	+0.036	L	-0.118	+0.322
D	+0.308	-0.150	M	0.000	+0.175
E	+0.182	-0.290	N	+0.154	+0.062
F	0.000	-0.343	P	+0.094	-0.122
G	-0.182	-0.290	R	-0.094	-0.122
H	-0.308	-0.150	S	-0.154	+0.062

CONTACT LOCATION 20-35

CONTACT NO.	X AXIS	Y AXIS	CONTACT NO.	X AXIS	Y AXIS	CONTACT NO.	X AXIS	Y AXIS	CONTACT NO.	X AXIS	Y AXIS
1	+0.053	+0.426	21	-0.427	-0.048	41	-0.098	-0.322	61	-0.134	-0.199
2	+0.146	+0.404	22	-0.427	+0.048	42	-0.184	-0.280	62	-0.208	-0.139
3	+0.232	+0.362	23	-0.406	+0.141	43	-0.258	-0.220	63	-0.237	-0.048
4	+0.306	+0.302	24	-0.365	+0.227	44	-0.311	-0.141	64	-0.237	+0.048
5	+0.365	+0.227	25	-0.306	+0.302	45	-0.332	-0.048	65	-0.208	+0.139
6	+0.406	+0.141	26	-0.232	+0.362	46	-0.332	+0.048	66	-0.134	+0.199
7	+0.427	+0.048	27	-0.146	+0.404	47	-0.311	+0.141	67	-0.048	+0.146
8	+0.427	-0.048	28	-0.053	+0.426	48	-0.258	+0.220	68	+0.048	+0.146
9	+0.406	-0.141	29	0.000	+0.323	49	-0.184	+0.280	69	+0.125	+0.090
10	+0.365	-0.227	30	+0.098	+0.322	50	-0.098	+0.322	70	+0.155	0.000
11	+0.306	-0.302	31	+0.184	+0.280	51	-0.048	+0.241	71	+0.125	-0.090
12	+0.232	-0.362	32	+0.258	+0.220	52	+0.048	+0.241	72	+0.048	-0.146
13	+0.146	-0.404	33	+0.311	+0.141	53	+0.134	+0.199	73	-0.048	-0.146
14	+0.053	-0.426	34	+0.332	+0.048	54	+0.208	+0.139	74	-0.125	-0.090
15	-0.053	-0.426	35	+0.332	-0.048	55	+0.237	+0.048	75	-0.155	0.000
16	-0.146	-0.404	36	+0.311	-0.141	56	+0.237	-0.048	76	-0.125	+0.090
17	-0.232	-0.362	37	+0.258	-0.220	57	+0.208	-0.139	77	0.000	+0.053
18	-0.306	-0.302	38	+0.184	-0.280	58	+0.134	-0.199	78	+0.048	-0.029
19	-0.365	-0.227	39	+0.098	-0.322	59	+0.048	-0.241	79	-0.048	-0.029
20	-0.406	-0.141	40	0.000	-0.347	60	-0.048	-0.241			

Contact Location 20-39 & 20-41

Note: Dimensions relate to the front pin face view. All dimensions are in inches. As per MIL-SPEC-1560A

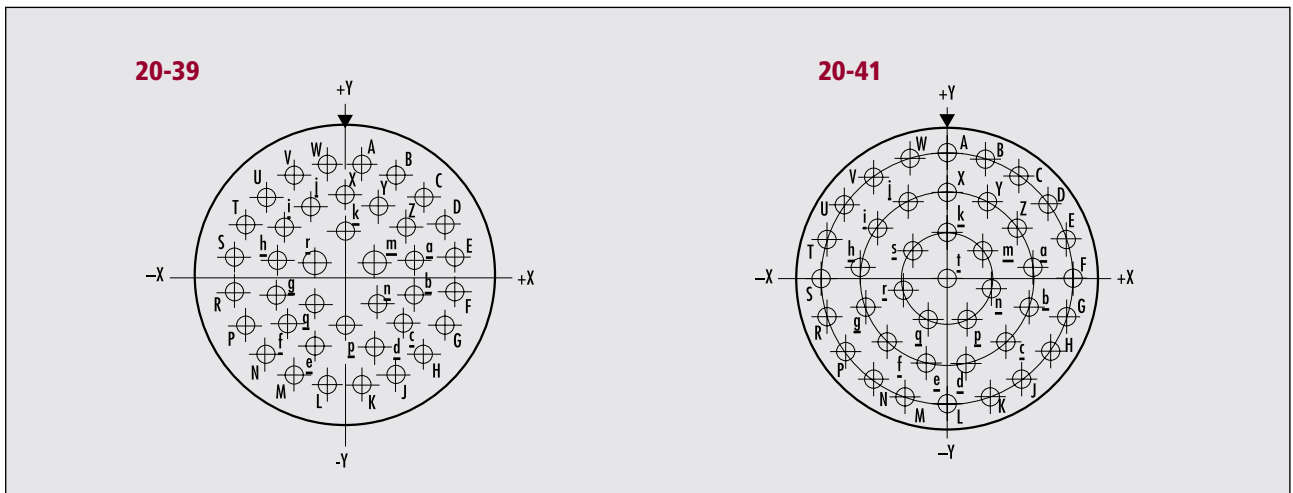

CONTACT LOCATION 20-39

CONTACT NO.	X AXIS	Y AXIS	CONTACT NO.	X AXIS	Y AXIS	CONTACT NO.	X AXIS	Y AXIS	CONTACT NO.	X AXIS	Y AXIS
A	+0.065	+0.411	L	-0.065	-0.411	X	0.000	+0.295	h	-0.280	+0.057
B	+0.189	+0.371	M	-0.189	-0.371	Y	+0.126	+0.256	i	-0.232	+0.179
C	+0.294	+0.294	N	-0.294	-0.294	Z	+0.232	+0.179	j	-0.126	+0.256
D	+0.371	+0.189	P	-0.371	-0.189	a	+0.280	+0.057	k	0.000	+0.164
E	+0.411	+0.065	R	-0.411	-0.065	b	+0.280	-0.074	m	+0.114	+0.048
F	+0.411	-0.065	S	-0.411	+0.065	c	+0.217	-0.179	n	+0.106	-0.107
G	+0.371	-0.189	T	-0.371	+0.189	d	+0.112	-0.265	p	0.000	-0.189
H	+0.294	-0.294	U	-0.294	+0.294	e	-0.112	-0.265	q	-0.106	-0.107
J	+0.189	-0.371	V	-0.189	+0.371	f	-0.217	-0.179	r	-0.114	+0.048
K	+0.065	-0.411	W	-0.065	+0.411	g	-0.280	-0.074			

CONTACT LOCATION 20-41

CONTACT NO.	X AXIS	Y AXIS	CONTACT NO.	X AXIS	Y AXIS	CONTACT NO.	X AXIS	Y AXIS	CONTACT NO.	X AXIS	Y AXIS
A	0.000	+0.418	M	-0.130	-0.397	Z	+0.233	+0.161	k	0.000	+0.150
B	+0.130	+0.397	N	-0.245	-0.338	a	+0.281	+0.034	m	+0.117	+0.094
C	+0.245	+0.338	P	-0.338	-0.245	b	+0.265	-0.100	n	+0.146	-0.033
D	+0.338	+0.245	R	-0.397	-0.130	c	+0.188	-0.212	p	+0.065	-0.135
E	+0.397	+0.130	S	-0.418	0.000	d	+0.068	-0.275	q	-0.065	-0.135
F	+0.418	0.000	T	-0.397	+0.130	e	-0.068	-0.275	r	-0.146	-0.033
G	+0.397	-0.130	U	-0.338	+0.245	f	-0.188	-0.212	s	-0.117	+0.094
H	+0.338	-0.245	V	-0.245	+0.338	g	-0.265	-0.100	t	0.000	0.000
J	+0.245	-0.338	W	-0.130	+0.397	h	-0.281	+0.034			
K	+0.130	-0.397	X	0.000	+0.283	i	-0.233	+0.161			
L	0.000	-0.418	Y	+0.132	+0.251	j	-0.132	+0.251			

For more information and ordering details please call our sales office on +44 (0) 1424 852722 or email autosport@deutsch.net

Contact Location 22-21 & 22-35

Note: Dimensions relate to the front pin face view. All dimensions are in inches. As per MIL-SPEC-1560A

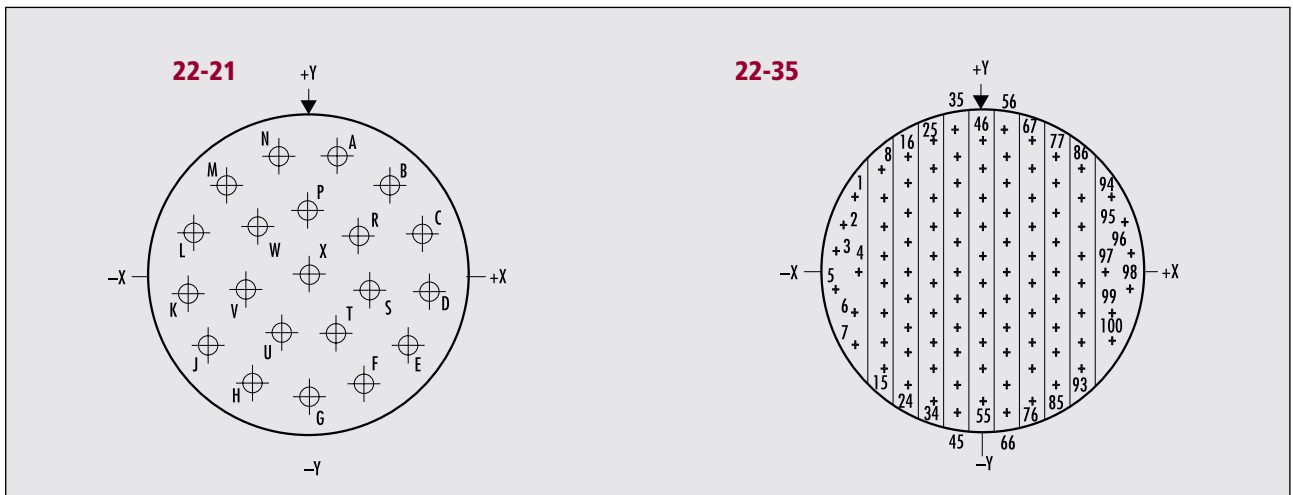

CONTACT LOCATION 22-21

CONTACT NO.	X AXIS	Y AXIS	CONTACT NO.	X AXIS	Y AXIS	CONTACT NO.	X AXIS	Y AXIS	CONTACT NO.	X AXIS	Y AXIS
A	+0.128	+0.385	G	0.000	-0.406	N	-0.128	+0.385	V	-0.214	-0.035
B	+0.289	+0.285	H	-0.183	-0.362	P	0.000	+0.245	W	-0.160	+0.146
C	+0.386	+0.123	J	-0.328	-0.239	R	+0.160	+0.146	X	0.000	0.000
D	+0.400	-0.065	K	-0.400	-0.065	S	+0.214	+0.035			
E	+0.328	-0.239	L	-0.386	+0.123	T	+0.094	-0.194			
F	+0.183	-0.362	M	-0.289	+0.285	U	-0.094	-0.194			

CONTACT LOCATION 22-35

CONTACT NO.	X AXIS	Y AXIS	CONTACT NO.	X AXIS	Y AXIS	CONTACT NO.	X AXIS	Y AXIS	CONTACT NO.	X AXIS	Y AXIS
1	-0.428	+0.241	26	-0.166	+0.333	51	0.000	-0.047	76	+0.166	-0.427
2	-0.467	+0.154	27	-0.166	+0.238	52	0.000	-0.142	77	+0.249	+0.380
3	-0.488	+0.061	28	-0.166	+0.143	53	0.000	-0.237	78	+0.249	+0.285
4	-0.415	0.000	29	-0.166	+0.048	54	0.000	-0.332	79	+0.249	+0.190
5	-0.488	-0.061	30	-0.166	-0.047	55	0.000	-0.427	80	+0.249	+0.095
6	-0.428	-0.142	31	-0.166	-0.142	56	+0.083	+0.475	81	+0.249	0.000
7	-0.428	-0.237	32	-0.166	-0.237	57	+0.083	+0.380	82	+0.249	-0.095
8	-0.332	+0.333	33	-0.166	-0.332	58	+0.083	+0.285	83	+0.249	-0.190
9	-0.332	+0.238	34	-0.166	-0.427	59	+0.083	+0.190	84	+0.249	-0.285
10	-0.332	+0.143	35	-0.083	+0.475	60	+0.083	+0.095	85	+0.249	-0.380
11	-0.332	+0.048	36	-0.083	+0.380	61	+0.083	0.000	86	+0.332	+0.333
12	-0.332	-0.047	37	-0.083	+0.285	62	+0.083	-0.095	87	+0.332	+0.238
13	-0.332	-0.142	38	-0.083	+0.190	63	+0.083	-0.190	88	+0.332	+0.143
14	-0.332	-0.237	39	-0.083	+0.095	64	+0.083	-0.285	89	+0.332	+0.048
15	-0.332	-0.332	40	-0.083	0.000	65	+0.083	-0.380	90	+0.332	-0.047
16	-0.249	+0.380	41	-0.083	-0.095	66	+0.083	-0.475	91	+0.332	-0.142
17	-0.249	+0.285	42	-0.083	-0.190	67	+0.166	+0.428	92	+0.332	-0.237
18	-0.249	+0.190	43	-0.083	-0.285	68	+0.166	+0.333	93	+0.332	-0.332
19	-0.249	+0.095	44	-0.083	-0.380	69	+0.166	+0.238	94	+0.428	+0.241
20	-0.249	0.000	45	-0.083	-0.475	70	+0.166	+0.143	95	+0.467	+0.154
21	-0.249	-0.095	46	0.000	+0.428	71	+0.166	+0.048	96	+0.488	+0.061
22	-0.249	-0.190	47	0.000	+0.333	72	+0.166	-0.047	97	+0.415	0.000
23	-0.249	-0.285	48	0.000	+0.238	73	+0.166	-0.142	98	+0.488	-0.061
24	-0.249	-0.380	49	0.000	+0.143	74	+0.166	-0.237	99	+0.428	-0.142
25	-0.166	+0.428	50	0.000	+0.048	75	+0.166	-0.332	100	+0.428	-0.237

Contact Location 22-55 & 24-29

Note: Dimensions relate to the front pin face view. All dimensions are in inches. As per MIL-SPEC-1560A

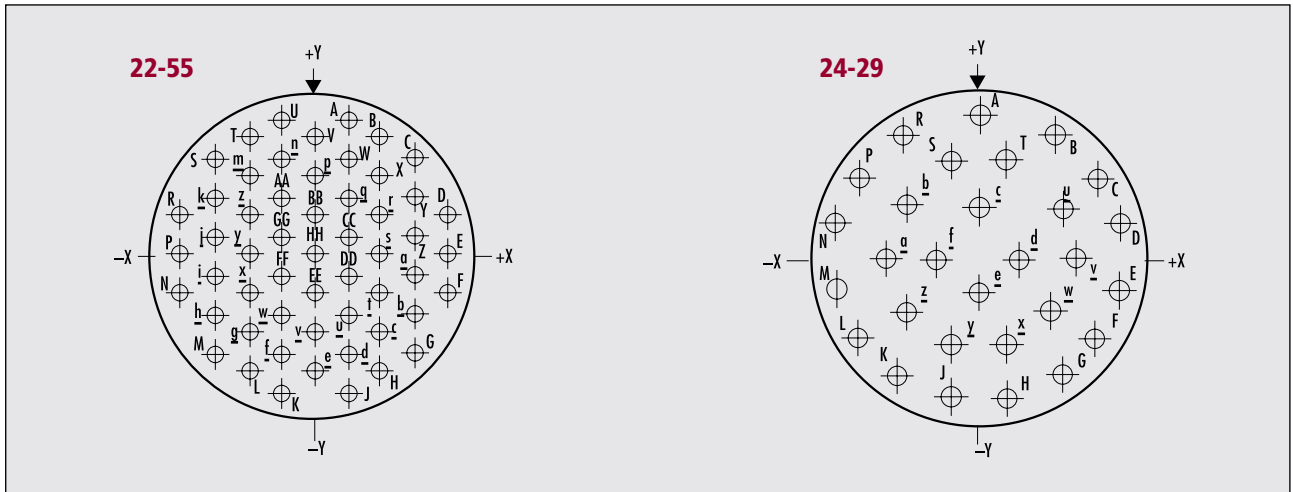

CONTACT LOCATION 22-55

CONTACT NO.	X AXIS	Y AXIS	CONTACT NO.	X AXIS	Y AXIS	CONTACT NO.	X AXIS	Y AXIS	CONTACT NO.	X AXIS	Y AXIS
A	+0.112	+0.455	R	-0.450	+0.130	f	-0.112	-0.325	v	0.000	-0.260
B	+0.225	+0.390	S	-0.336	+0.325	g	-0.225	-0.260	w	-0.112	-0.195
C	+0.336	+0.325	T	-0.225	+0.390	h	-0.336	-0.195	x	-0.225	-0.130
D	+0.450	+0.130	U	-0.112	+0.455	i	-0.336	-0.065	y	-0.225	0.000
E	+0.450	0.000	V	0.000	+0.390	j	-0.336	+0.065	z	-0.225	+0.130
F	+0.450	-0.130	W	+0.112	+0.325	k	-0.336	+0.195	AA	-0.112	+0.195
G	+0.336	-0.325	X	+0.225	+0.260	m	-0.225	+0.260	BB	0.000	+0.130
H	+0.225	-0.390	Y	+0.336	+0.195	n	-0.112	+0.325	CC	+0.112	+0.065
J	+0.112	-0.455	Z	+0.336	+0.065	p	0.000	+0.260	DD	+0.112	-0.065
K	-0.112	-0.455	a	+0.336	-0.065	q	+0.112	+0.195	EE	0.000	-0.130
L	-0.225	-0.390	b	+0.336	-0.195	r	+0.225	+0.130	FF	-0.112	-0.065
M	-0.336	-0.325	c	+0.225	-0.260	s	+0.225	0.000	GG	-0.112	+0.065
N	-0.450	-0.130	d	+0.112	-0.325	t	+0.225	-0.130	HH	0.000	0.000
P	-0.450	0.000	e	0.000	-0.390	u	+0.112	-0.195			

CONTACT LOCATION 24-29

CONTACT NO.	X AXIS	Y AXIS	CONTACT NO.	X AXIS	Y AXIS
A	0.000	+0.481	S	-0.091	+0.321
B	+0.258	+0.406	T	+0.091	+0.321
C	+0.395	+0.277	U	+0.228	+0.194
D	+0.469	+0.109	V	+0.319	0.000
E	+0.469	-0.109	W	+0.240	-0.181
F	+0.395	-0.277	X	+0.091	-0.290
G	+0.263	-0.406	Y	-0.091	-0.290
H	+0.091	-0.472	Z	-0.240	-0.181
J	-0.091	-0.472	a	-0.319	0.000
K	-0.263	-0.406	b	-0.228	+0.194
L	-0.395	-0.277	c	0.000	+0.161
M	-0.469	-0.109	d	+0.134	0.000
N	-0.469	+0.109	e	0.000	-0.130
P	-0.395	+0.277	f	-0.134	0.000
R	-0.258	+0.406			

For more information and ordering details please call our sales office on +44 (0) 1424 852722 or email autosport@deutsch.net

Contact Location 24-35

Note: Dimensions relate to the front pin face view. All dimensions are in inches. As per MIL-SPEC-1560A

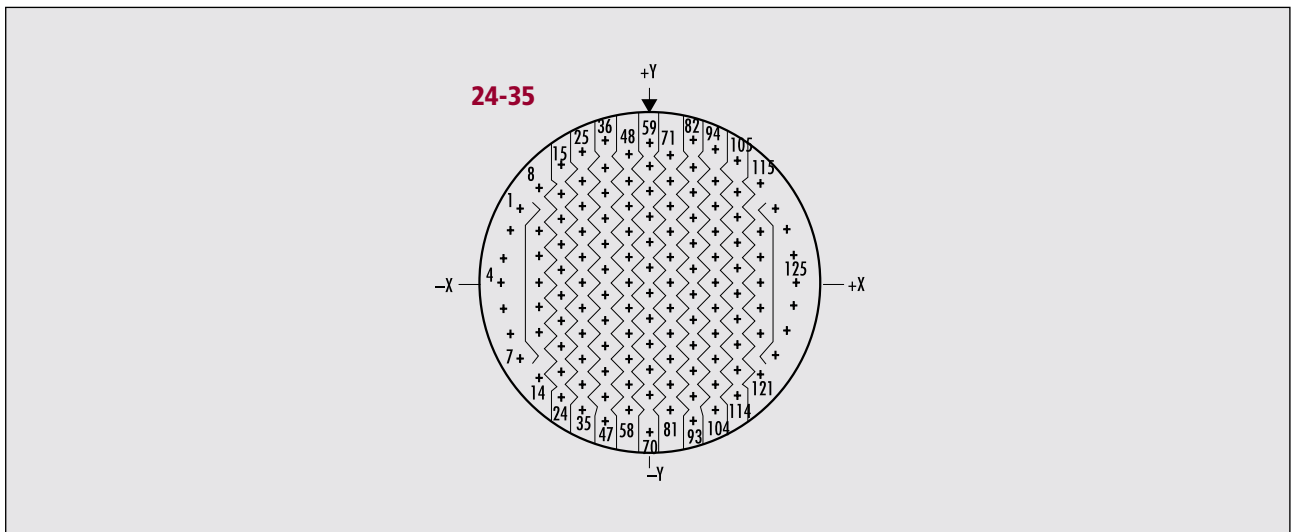

CONTACT LOCATION 24-35

CONTACT NO.	X AXIS	Y AXIS	CONTACT NO.	X AXIS	Y AXIS	CONTACT NO.	X AXIS	Y AXIS	CONTACT NO.	X AXIS	Y AXIS
1	-0.479	+0.279	33	-0.249	-0.285	65	0.000	-0.047	97	+0.249	+0.190
2	-0.520	+0.190	34	-0.249	-0.380	66	0.000	-0.142	98	+0.249	+0.095
3	-0.546	+0.095	35	-0.249	-0.475	67	0.000	-0.237	99	+0.249	0.000
4	-0.555	0.000	36	-0.160	+0.531	68	0.000	-0.332	100	+0.249	-0.095
5	-0.546	-0.095	37	-0.166	+0.427	69	0.000	-0.427	101	+0.249	-0.190
6	-0.520	-0.190	38	-0.166	+0.332	70	0.000	-0.555	102	+0.249	-0.285
7	-0.479	-0.279	39	-0.166	+0.237	71	+0.083	+0.475	103	+0.249	-0.380
8	-0.424	+0.357	40	-0.166	+0.142	72	+0.083	+0.380	104	+0.249	-0.475
9	-0.415	+0.190	41	-0.166	+0.047	73	+0.083	+0.285	105	+0.332	+0.444
10	-0.415	+0.095	42	-0.166	-0.047	74	+0.083	+0.190	106	+0.332	+0.332
11	-0.415	0.000	43	-0.166	-0.142	75	+0.083	+0.095	107	+0.332	+0.237
12	-0.415	-0.095	44	-0.166	-0.237	76	+0.083	0.000	108	+0.332	+0.142
13	-0.415	-0.190	45	-0.166	-0.332	77	+0.083	-0.095	109	+0.332	+0.047
14	-0.424	-0.357	46	-0.166	-0.427	78	+0.083	-0.190	110	+0.332	-0.047
15	-0.332	+0.444	47	-0.166	-0.522	79	+0.083	-0.285	111	+0.332	-0.142
16	-0.332	+0.332	48	-0.083	+0.475	80	+0.083	-0.380	112	+0.332	-0.237
17	-0.332	+0.237	49	-0.083	+0.380	81	+0.083	-0.475	113	+0.332	-0.332
18	-0.332	+0.142	50	-0.083	+0.285	82	+0.160	+0.531	114	+0.332	-0.427
19	-0.332	+0.047	51	-0.083	+0.190	83	+0.166	+0.427	115	+0.424	+0.357
20	-0.332	-0.047	52	-0.083	+0.095	84	+0.166	+0.332	116	+0.415	+0.190
21	-0.332	-0.142	53	-0.083	0.000	85	+0.166	+0.237	117	+0.415	+0.095
22	-0.332	-0.237	54	-0.083	-0.095	86	+0.166	+0.142	118	+0.415	0.000
23	-0.332	-0.332	55	-0.083	-0.190	87	+0.166	+0.047	119	+0.415	-0.095
24	-0.332	-0.427	56	-0.083	-0.285	88	+0.166	-0.047	120	+0.415	-0.190
25	-0.249	+0.496	57	-0.083	-0.380	89	+0.166	-0.142	121	+0.424	-0.357
26	-0.249	+0.380	58	-0.083	-0.475	90	+0.166	-0.237	122	+0.479	+0.279
27	-0.249	+0.285	59	0.000	+0.522	91	+0.166	-0.332	123	+0.520	+0.190
28	-0.249	+0.190	60	0.000	+0.427	92	+0.166	-0.427	124	+0.546	+0.095
29	-0.249	+0.095	61	0.000	+0.332	93	+0.166	-0.522	125	+0.555	0.000
30	-0.249	0.000	62	0.000	+0.237	94	+0.249	+0.496	126	+0.546	-0.095
31	-0.249	-0.095	63	0.000	+0.142	95	+0.249	+0.380	127	+0.520	-0.190
32	-0.249	-0.190	64	0.000	+0.047	96	+0.249	+0.285	128	+0.479	-0.279

Contact Location 24-61

Note: Dimensions relate to the front pin face view. All dimensions are in inches. As per MIL-SPEC-1560A

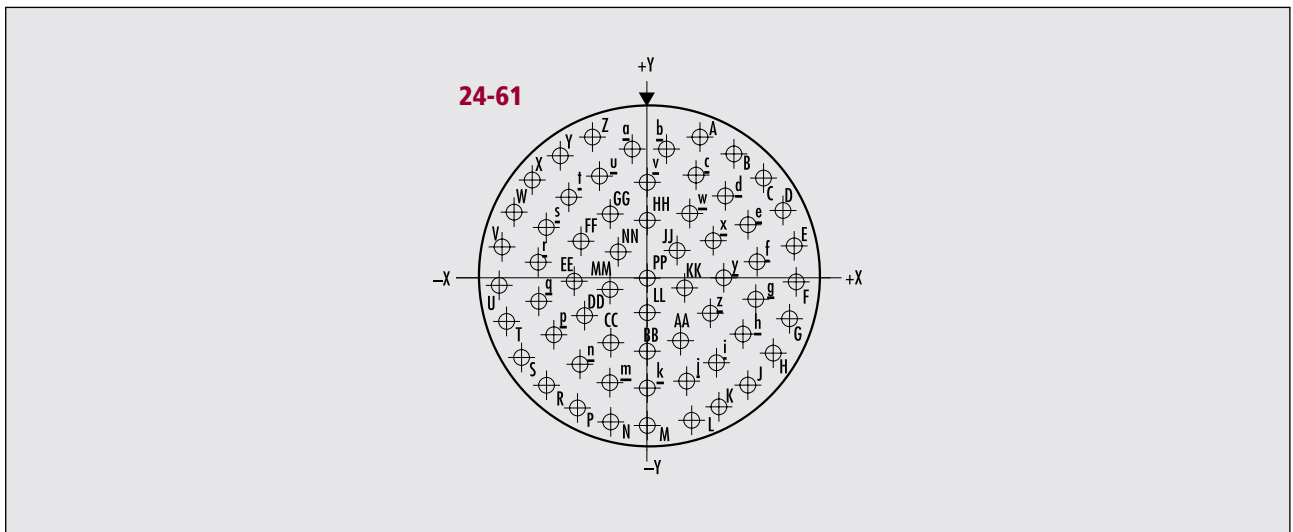

CONTACT LOCATION 24-61

CONTACT NO.	X AXIS	Y AXIS	CONTACT NO.	X AXIS	Y AXIS	CONTACT NO.	X AXIS	Y AXIS	CONTACT NO.	X AXIS	Y AXIS
A	+0.196	+0.500	T	-0.511	-0.164	j	+0.133	-0.379	BB	0.000	-0.267
B	+0.314	+0.435	U	-0.536	-0.030	k	0.000	-0.402	CC	-0.131	-0.233
C	+0.413	+0.343	V	-0.527	-0.101	m	-0.133	-0.379	DD	-0.228	-0.139
D	+0.485	+0.230	W	-0.485	+0.230	n	-0.251	-0.314	EE	-0.267	-0.010
E	+0.527	+0.101	X	-0.413	+0.343	p	-0.341	-0.213	FF	-0.237	+0.122
F	+0.536	-0.030	Y	-0.314	+0.435	q	-0.392	-0.088	GG	-0.147	+0.223
G	+0.511	-0.164	Z	-0.196	+0.500	r	-0.399	+0.046	HH	0.000	+0.200
H	+0.454	-0.287	a	-0.068	+0.454	s	-0.362	+0.175	JJ	+0.105	+0.094
J	+0.368	-0.391	b	+0.068	+0.454	t	-0.285	+0.283	KK	+0.135	-0.041
K	+0.259	-0.470	c	+0.173	+0.363	u	-0.173	+0.363	LL	0.000	-0.132
L	+0.134	-0.519	d	+0.285	+0.283	v	0.000	+0.338	MM	-0.135	-0.041
M	0.000	-0.537	e	+0.362	+0.175	w	+0.147	+0.223	NN	-0.105	-0.094
N	-0.134	-0.519	f	+0.399	+0.046	x	+0.237	+0.122	PP	0.000	0.000
P	-0.259	-0.470	g	+0.392	-0.088	y	+0.267	-0.010			
R	-0.368	-0.391	h	+0.341	-0.213	z	+0.228	-0.139			
S	-0.454	-0.287	i	-0.251	-0.314	AA	+0.131	-0.233			

For more information and ordering details please call our sales office on +44 (0) 1424 852722 or email autosport@deutsch.net

A Accessories - Mechanical devices such as cable clamps added to connector shells, which are attachable to connectors to make up the total connector assembly.

Adapter (Adaptor) - An intermediate device to provide for attaching special accessories or to provide special mounting means.

B Back-mounted - A connector mounted from the inside of a panel or box with its mounting flange inside the equipment.

Bayonet coupling, rotary - A quick coupling device for mating connectors utilising pins on a connector and ramps on the mating connector. Mating and unmating is accomplished by rotating the coupling ring.

Body, connector - The main portion of a connector to which contacts and other components are attached. This term is not used with connectors incorporating non-integral shells in their construction.

Boot - A form placed around the wire terminations of a multiple contact connector as a protective housing or as a container for potting compound.

Braid - Flexible conductor made of a woven or braided assembly of fine wires.

Bucket - The section of a contact where the wire is crimped.

C Cable clamp/tie - A mechanical clamp attached to the cable side of the connector to support the cable or wire bundle, provide strain relief, and absorb vibration and shock otherwise transmitted by the cable to the contact/wire connection.

Cable shielding clamp (Bandit) - A device consisting of a sealing member and cable support designed to terminate the screen (shield) of an electrical cable.

Circumferential crimp - The type of crimp where the crimping dies completely surround a contact bucket resulting in symmetrical indentations in the bucket.

Coaxial contact - A contact having two conducting surfaces, a centre contact and a coaxially placed sleeve.

Colour coding - A system of identification of terminals and related devices.

Connector, electrical - A device, either a plug or receptacle, used to terminate or connect the conductors of individual wires or cables and provide a means to continue the conductors to a mating connector or printed circuit board.

Contact - The conductive element in a connector which makes actual contact for the purpose of transferring electrical energy.

Contact area - The area in contact between two conductors, two contacts, or a conductor and a contact permitting the flow of electricity.

Contact arrangement - The number, spacing and arrangement of contacts in a connector.

Contact engaging and separating force - Force needed to either engage or separate mating contacts.

Contact resistance - Electrical resistance of a pair of engaged contacts. Resistance may be measured in ohms or millivolt drop at a specified current over the engaged contacts.

Contact retainer - A device either on the contact or in the insert to retain the contact in an insert or body.

Contact retention - The axial load in either direction which a contact can withstand without being dislodged from its normal position within an insert or body.

Contact size - An assigned number denoting the size of the contact engaging end.

Contact shoulder - The flanged portion of a contact which limits its travel into the insert.

Coupling ring - That portion of a plug which aids in the mating or unmating of a plug and receptacle and holds the plug to the receptacle.

Crimp - The physical compression (deformation) of a contact bucket around a conductor in order to make an electrical connection.

Crimping - A pressure method of mechanically securing a terminal, splice or contact to a conductor.

Crimping dies - Portion of the crimping tool that shapes the crimp.

Crimping tool - Mechanism used for crimping.

D Depth of crimp - The distance the indenter penetrates into the barrel.

Die closure - The gap between indenter dies at full handle closure. Usually defined by Go/No-Go dimensions.

Dielectric - A material having electrical insulating properties.

E Environmentally sealed - A device that is provided with gaskets, seals, grommets, potting or other means to keep out moisture, dirt, air or dust which might reduce its performance. Does not include non-physical environments such as RF and radiation.

Extraction tool - Device to extract contacts from a connector.

F Ferrule - A short tube. Used to make connections to shielded or coaxial cables. Also used in connectors to reduce transmission of torque to grommet.

Flange, connector - A projection extending from or around the periphery of a connector with provisions to permit mounting the connector to a panel.

Filter contact - A contact which provides R.F.I. suppression without altering its normal function.

Front mounted - A connector mounted on the outside of a panel or box with its mounting flange outside the equipment.

Full cycle control - Controls placed on the crimping cycle of crimping tools forcing the tool to be closed to its fullest extent completing the crimping cycle before the tool can be opened.

G Grommet, connector - An elastomeric seal used on the cable side of a connector to seal the connector against moisture, air and dirt.

Grounding fingers - A set of spring fingers provided in the connector to allow shell to shell grounding, before contacts mate and after they separate.

Guide pin - A pin or rod extending beyond the mating faces of a connector designed to guide the closing or mating of the connector to ensure proper engagement of contacts.

H Head assembly - A positioner or turret designed to attach to a crimping tool.

Hermaphroditic connector - A connector design which utilises pin and socket contacts in a balanced arrangement such that both mating connectors are identical. The contacts may also be hermaphroditic, and may be arranged as male and female contacts as for pin and sockets. Hermaphroditic contacts may also be used in a manner such that one half of each contact mating surface protrudes beyond the connector interface and both mating connectors are identical.

Hermaphroditic contact - A contact design which is neither pin nor socket and which mates with other contacts of the same design.

Hermetic - The process of sealing a connector with glass to enable high pressure or fuel resistant seals.

Housing, connector, electrical - Connector less insert, but with insert-retaining and positioning hardware required by standard construction.

I Indenter - That part of a crimping die, usually the moving part, which indents or compresses the contact barrel.

Insert, electrical connector - An insulating element with or without contact(s), designed to position and support contacts in a connector.

Inspection gauge - It shall conform to the gauging limits specified on the applicable tool specification sheet.

Inspection hole - A hole placed at the bottom end of a contact wire barrel to permit visual inspection to see that the conductor has been inserted to the proper depth in the barrel prior to crimping.

Insertion tool - A device used to install contacts into a connector.

Insulation support - The portion of a barrel similar to an insulation grip except that it is not compressed around the conductor insulation.

Interface - The two surfaces on the contact side of mating connectors or plug-in component and receptacle, which face each other when mated.

Interfacial seal - A sealing of mated connectors over the whole area of the interface to provide sealing around each contact.

J Jacket - The outermost layer of insulating material of a cable or wire.

Jackscrew (screwlock) - A screw attached to one half of a two piece multiple contact connector used to draw and hold both halves together and to separate them.

K Key - A short pin or other projection which slides in a mating slot, hole, groove or keyway to guide two parts being assembled. Generally used in shell-enclosed connectors to obtain polarisation.

L Lanyard - A device attached to certain connectors which permits uncoupling and separation of connector halves by a pull on a wire or cable.

Locater - Device for positioning terminals, splices, or contacts into crimping dies, positioner, or turret heads.

M Mate - The joining of two connectors.

Millivolt drop test - A test designed to determine the voltage loss due to resistance of a crimped joint.

NO Nick (notch) - A cut or notch in conductor strands or insulation.

PQ Pigtail - A short wire extending from an electric or electronic device to serve as a jumper or ground connection.

Pin contact - A contact having an engagement end that enters the socket contact.

Plating - The overlaying of a thin coating of metal on metallic components to improve conductivity, provide for easy soldering or prevent rusting or corrosion.

Plug connector - An electrical fitting with pin, socket, or pin and socket contacts, constructed to be affixed to the end of a cable, conduit, coaxial line, cord or wire for convenience in joining with another electrical connector(s), and not designed to be mounted on a bulkhead, chassis or panel.

Polarise - The arrangement of mating connectors such that the connector can be mated in only one way.

Positioner - A device when attached to a crimping tool locates the contact in the correct position.

Potting - The permanent sealing of the cable end of a connector with a compound or material to exclude moisture and/or to provide a strain relief.

Pull-out force - Force necessary to separate a conductor from a contact or terminal, or a contact from a connector, by exerting a tensile pull.

R Rack and panel - The type of connector that is attached to a panel or side of equipment so that when these members are brought together, the connector is engaged.

Radio frequency contact (RF contact) - An impedance matched shielded contact.

Range, wire - The sizes of conductors accommodated by a particular barrel. Also the diameters of wires accommodated by a sealing grommet.

Ratchet control - A device to ensure the full crimping cycle of a crimping tool.

Receptacle, connector - An electrical fitting with contacts constructed to be electrically connected to a cable, coaxial line, cord, or wire to join with another electrical connector(s), and is designed to be mounted on a bulkhead, wall, chassis, or panel.

Removal tool - A device used to remove a contact from a connector.

S Safety wire - A means of safety wiring a plug and/or receptacle to prevent the loosening or vibrating free of the plug from the receptacle.

Scoop-proof - Recessed pins minimise potential contact damage in 100% scoop-proof connectors. In blind mating application, the mating shells cannot "scoop" the pins and cause a shorting or bending of contacts.

Sealing plug - A plug which is inserted to fill an unoccupied contact aperture for sealing in a connector insert, especially in environmental connectors.

Seamless terminal or splice - Terminal or splice conductor barrel made without an open seam.

Selective plating - The application of plating material to a limited portion of a connector contact, especially those areas susceptible to wear.

Service rating - The maximum voltage or current with a connector is designed to carry continuously.

Shell, electrical connector - The outside case of a connector into which the dielectric material and contacts are assembled.

Shielded contact - A contact which carries alternating current and is shielded from unwanted signals (RFI and EMI). Generally, these contacts are not impedance matched.

Socket contact - A contact having an engagement end that will accept entry of a pin contact.

Solderless connection - The joining of two metals by pressure means without the use of solder, braze, or any method requiring heat.

Splice - Device used to join two or more conductors to each other.

Stop plate (see Locater) - A device attached to a crimping tool to properly locate a terminal, splice or contact in the tool prior to crimping.

Strip - To remove insulation from a conductor.

TU Tensile testing - A controlled pull test on the crimp joint to determine its mechanical strength.

Terminal - Point of connection for closing an electric circuit or an alternative reference to contact.

Threaded coupling - A means of coupling mating connectors by engaging threads in a coupling ring with threads on a receptacle shell.

Thermocouple contact - Contact of special material used in connectors employed in thermocouple applications. Material often used are iron, constantan, chromel, alumel and others.

Turret head - A device that contains more than one Locater which can be indexed by rotating a circular barrel, and when attached to a crimping tool, positions the contact.

WXYZ Zero-force connector - A connector in which the contact surfaces do not mechanically touch until it is completely mated thus requiring no insertion force. After mating the contacts are actuated in some fashion to make intimate electrical contact.

AWG / Metric Conductor Chart

AWG	STRANDING	APPROX O.D.		CIRCULAR MIL AREA	SQUARE		WEIGHT		D.C RESISTANCE OHMS	
		INCHES	MM		INCHES	MM	LBS/1000FT.	KG/KM	1000FT.	K/M
36	Solid	0.0050	0,127	25.0	-	0,013	0.076	0,113	445.0	1460,0
36	7/44	0.006	0,152	28.0	-	0,014	0.085	0,126	371.0	1271,0
34	Solid	0.0063	0,160	39.7	-	0,020	0.120	0,179	280.0	918,0
34	7/42	0.0075	0,192	43.8	-	0,022	0.132	0,196	237.0	777,0
32	Solid	0.008	0,203	67.3	0.0001	0,032	0.194	0,289	174.0	571,0
32	7/40	0.008	0,203	67.3	0.0001	0,034	0.203	0,302	164.0	538,0
32	19/44	0.009	0,229	76.0	0.0001	0,039	0.230	0,342	136.0	448,0
30	Solid	0.010	0,254	100.0	0.0001	0,051	0.30	0,45	113.0	365,0
30	7/38	0.012	0,305	112.0	0.0001	0,057	0.339	0,504	103.0	339,0
30	19/42	0.012	0,305	118.8	0.0001	0,061	0.359	0,534	87.3	286,7
28	Solid	0.013	0,330	159.0	0.0001	0,080	0.48	0,72	70.8	232,0
28	7/36	0.015	0,381	175.0	0.0001	0,072	0.529	0,787	64.9	213,0
28	19/40	0.016	0,406	182.6	0.0001	0,093	0.553	0,823	56.7	186,0
27	7/35	0.018	0,457	219.5	0.0002	0,112	0.664	0,988	54.5	179,0
26	Solid	0.016	0,409	256.0	0.0002	0,128	0.770	1,14	43.6	143,0
26	10/36	0.021	0,533	250.0	0.0002	0,128	0.757	1,13	41.5	37,0
26	19/38	0.020	0,508	304.0	0.0002	0,155	0.920	1,37	34.4	113,0
26	7/34	0.019	0,483	277.8	0.0002	0,142	0.841	1,25	7.3	122,0
24	Solid	0.020	0,511	404.0	0.0003	0,205	1.22	1,82	27.3	89,4
24	7/32	0.024	0,610	448.0	0.0004	0,229	1.36	2,02	23.3	76,4
24	10/34	0.023	0,582	396.9	0.0003	0,202	1.20	1,79	26.1	85,6
24	19/36	0.024	0,610	475.0	0.0004	0,242	1.43	2,13	21.1	69,2
24	41/40	0.023	0,582	384.4	0.0003	0,196	1.16	1,73	25.6	84,0
22	Solid	0.025	0,643	640.0	0.0005	0,324	1.95	2,91	16.8	55,3
22	7/30	0.030	0,762	700.0	0.0006	0,357	2.12	3,16	14.7	48,4
22	19/34	0.031	0,787	754.1	0.0006	0,385	2.28	3,39	13.7	45,1
22	26/36	0.030	0,762	650.0	0.0005	0,332	1.97	2,93	15.9	52,3
20	Solid	0.032	0,813	1020.0	0.0008	0,519	3.10	4,61	10.5	34,6
20	7/28	0.038	0,965	1111.0	0.0009	0,562	3.49	5,19	10.3	33,8
20	10/30	0.035	0,889	1000.0	0.0008	0,510	3.03	4,05	10.3	33,9
20	19/32	0.037	0,940	1216.0	0.0010	0,620	3.70	5,48	8.6	28,3
20	26/34	0.036	0,914	1031.9	0.0008	0,526	3.12	4,64	10.0	33,0
20	41/36	0.036	0,914	1025.0	0.0008	0,523	3.10	4,61	10.0	32,9
18	Solid	0.040	1,020	1620.0	0.0013	0,823	4.92	7,32	6.6	21,8
18	7/26	0.048	1,219	1769.6	0.0014	0,902	5.36	7,98	5.9	9,2
18	16/30	0.047	1,194	1600.0	0.0013	0,816	4.84	7,20	8.5	21,3
18	19/30	0.049	1,245	1900.0	0.0015	0,969	5.75	8,56	5.5	17,9
18	41/34	0.047	1,194	1627.3	0.0013	0,830	4.92	7,32	6.4	20,9
18	65/36	0.047	1,194	1625.0	0.0013	0,829	4.91	7,31	6.4	21,0
16	Solid	0.051	1,290	2580.0	0.0020	1,310	7.81	11,60	4.2	13,7
16	7/24	0.060	1,524	2828.0	0.0022	1,442	8.56	12,74	3.7	12,0
16	65/34	0.059	1,499	2579.9	0.0020	1,316	7.81	11,62	4.0	13,2

AWG	STRANDING	APPROX O.D.		CIRCULAR MIL AREA	SQUARE		WEIGHT		D.C RESISTANCE OHMS	
		INCHES	MM		INCHES	MM	LBS/1000FT.	KG/KM	1000FT.	K/M
16	26/30	0.059	1,499	2600.0	0.0021	1,326	7.87	11,71	4.0	13,1
16	19/29	0.058	1,473	2426.3	0.0019	1,327	7.35	10,94	4.3	14,0
16	105/36	0.059	1,499	2625.0	0.0021	1,339	7.95	11,83	4.0	13,1
14	Solid	0.064	1,630	4110.0	0.0032	2,080	12.40	18,50	2.6	8,6
14	7/22	0.073	1,854	4480.0	0.0035	2,285	13.56	20,18	2.3	7,6
14	19/27	0.073	1,854	3830.4	0.0030	1,954	11.59	17,25	2.7	8,9
14	41/30	0.073	1,854	4100.0	0.0032	2,091	12.40	18,45	2.5	8,3
14	105/34	0.073	1,854	4167.5	0.0033	2,125	12.61	18,77	2.5	8,2
12	Solid	0.081	2,05	6,530.0	0.0052	3,31	19.80	29,50	1.7	5,4
12	7/20	0.096	2,438	7,168.0	0.0057	3,66	21.69	32,28	1.5	4,8
12	19/25	0.093	2,369	6,087.6	0.0048	3,105	18.43	27,43	1.7	5,6
12	65/30	0.095	2,413	6,500.0	0.0051	3,315	19.66	29,26	1.8	5,7
12	165/34	0.095	2,413	6,548.9	0.0052	3,340	19.82	29,49	1.6	5,2
10	Solid	0.102	2,59	1,038.0	0.0083	5,26	31.4	46,80	1.0	3,4
10	37/26	0.115	2,921	9,353.6	0.0074	4,770	28.31	41,13	1.1	3,6
10	49/27	0.116	2,946	9,878.4	0.0078	5,038	29.89	44,48	1.1	3,6
10	105/30	0.116	2,946	10,530.0	0.0083	5,370	31.76	47,26	0.98	3,2
8	49/25	0.188	4,775	16,589.0	0.0130	8,403	47.53	70,73	0.67	2,2
8	133/29	0.166	4,216	16,851.0	0.0132	8,536	51.42	76,52	0.61	2,0
8	655/36	0.166	4,216	16,625.0	0.0131	8,422	49.58	73,78	0.62	2,0
6	133/27	0.210	5,334	26,799.0	0.0210	13,575	81.14	120,74	0.47	1,5
6	259/30	0.210	5,334	26,029.0	0.0204	13,185	78.35	116,59	0.40	1,3
6	1050/36	0.204	5,181	26,250.0	0.0206	13,297	79.47	118,26	0.39	1,3
4	133/25	0.257	6,527	42,613.0	0.0334	21,587	129.01	191,98	0.24	0,80
4	259/28	0.261	6,629	41,388.0	0.0324	20,966	158.02	235,15	0.20	0,66
4	1666/36	0.290	7,366	41,650.0	0.0327	21,099	126.10	187,65	0.25	0,82
2	133/23	0.328	8,331	67,763.0	0.0532	34,327	205.62	305,98	0.15	0,50
2	259/26	0.325	8,255	65,811.0	0.0516	33,338	198.14	294,85	0.16	0,52
2	665/30	0.335	8,509	66,832.0	0.0524	33,856	201.16	299,35	0.16	0,52
2	2646/36	0.379	9,626	66,150.0	0.0519	33,510	200.28	298,04	0.16	0,52
1	133/22	0.365	9,271	85,439.0	0.0671	43,282	257.60	383,34	0.12	0,40
1	259/25	0.375	9,525	82,982.0	0.0651	42,037	251.20	373,81	0.13	0,41
1	836/30	0.377	9,575	84,015.0	0.0659	42,562	247.10	367,71	0.13	0,42
1	2107/34	0.375	9,525	83,753.0	0.0657	42,428	253.29	376,92	0.12	0,41
1/0	133/21	0.464	11,786	107,743.0	0.0846	54,581	327.05	486,68	0.096	0,31
1/0	259/24	0.422	10,668	104,636.0	0.0821	53,007	316.76	471,37	0.099	0,32
2/0	133/20	0.500	12,700	135,926.0	0.1067	68,858	412.17	613,35	0.077	0,25
2/0	259/23	0.473	12,014	131,960.0	0.1036	66,849	400.41	595,85	0.077	0,25
3/0	259/22	0.509	12,928	166,381.0	0.1306	84,286	501.70	746,58	0.062	0,20
3/0	427/24	0.538	13,665	167,401.0	0.1314	87,802	522.20	777,09	0.059	0,19
4/0	259/21	0.606	15,392	209,815.0	0.1647	106,289	638.88	950,72	0.049	0,16
4/0	427/23	0.605	15,367	212,342.0	0.1667	107,569	660.01	982,16	0.047	0,15

CONTACT TYPE

CONTACT SIZE	PART NO.	P/S	WIRE RANGE	COLOUR BAND	MAX CURRENT	CRIMP TOOL	POSITIONER		PLASTIC TOOLS INSERT/REMOVAL
Size 24 (ASDD excluding 9-Way)	605719-31	P	24-30	None	3 Amps	M22520/2-01	610286	P	605837 Orange/White
	605721	S					610287	S	
Size 24 (ASDD 9 Way & ASU 5-Way)	605705-31	P	24-30	None	3 Amps	M22520/2-01	605839	P	605837 Orange/White
	605704	S					605840	S	
Size 23	604927-31	P	22-28	None	3 Amps	M22520/2-01	604972	P	M81969/14-01 Green/White
	604935	S					604973	S	
Size 22	38941-22	P	22-26	Orange, Blue, Black	5 Amps	M22520/2-01	M22520/2-09	P	M81969/14-01 Green/White
	38943-22	S		Orange, Yellow, Grey			M22520/2-07	S	
Size 20	38941-20	P	20-24	Orange, Blue, Orange	7.5 Amps	M22520/2-01	M22520/2-10	P	M81969/14-10 Red/Orange
	38943-20	S		Orange, Green, Brown			M22520/2-10	S	
Size 16	38941-16	P	16-20	Orange, Blue, Yellow	20 Amps	M22520/1-01	M22520/1-04	P	M81969/14-03 Blue/White
	38943-16	S		Orange, Green, Red			M22520/1-04	S	
AS Mini Size 22	38941-22	P	22-26	Orange, Blue, Black	5 Amps	M22520/2-01	M22520/2-09	P	M81969/14-01 Green/White
	604887	S		None			605000	S	
AS Mini Size 20	38941-20	P	20-24	Orange, Blue, Orange	7.5 Amps	M22520/2-01	M22520/2-10	P	M81969/14-10 Red/Orange
	6862-201-20278	S		None			M22520/2-10	S	
AS Composite/ ASU 3-Way	604946-31	P	22-28	None	5 Amps	M22520/2-01	605463	P	M81969/14-01 Green/White
	604984	S					605464	S	

BOOT INFORMATION

SHELL SIZE	STRAIGHT BOOT		90 DEGREE BOOT	
	RAYCHEM	HELLERMAN	RAYCHEM	HELLERMAN
ASU (Size 3)	204W221-25-G03	1037-4-G	224W221-25-G03	1182-4-G
AS Composite	204W221	1030-4-G	224W221	1181-4-G
AS Micro ^{Lite}	204W221	1030-4-G	224W221	1181-4-G
AS Micro	202A111	113-4-G	222A111	1108-4-G
AS Mini	202K121	152-42-G	222K121	1152-4-G
08	202K121	152-42-G	222K121	1152-4-G
10	202K132	152-42-G	222K121	1152-4-G
12	202K142	154-42-G	222K132	1154-4-G
14	202K142	155-42-G	222K142	1155-4-G
16	202K153	156-42-G	222K152	1156-4-G
18	202K153	156-42-G	222K152	1156-4-G
20	202K163	157-43-G	222K163	1157-4-G
22	202K163	157-43-G	222K163	1157-4-G
24	202K174	157-43-G	222K174	1157-4-G

ACCESSORIES

SHELL SIZE	NUTPLATE	GASKET	PLUG / RECEPTACLE	PROTECTIVE CAP
3/5 (ASU)	ATM396-3	GV-3	Plug	605687
			Receptacle	605684
6 (ASL)	ATM396-6	GV-6	Plug	604027
			Receptacle	604029
7 (Mini)	ATM396-7	GV-7	Plug	AS8-07
			Receptacle	AS9-07
08	ATM396-8	GV-8	Plug	AS8-08
			Receptacle	AS9-08
10	ATM396-10	GV-10	Plug	AS8-10
			Receptacle	AS9-10
12	ATM396-12	GV-12	Plug	AS8-12
			Receptacle	AS9-12
14	ATM396-14	GV-14	Plug	AS8-14
			Receptacle	AS9-14
16	ATM396-16	GV-16	Plug	AS8-16
			Receptacle	AS9-16
18	ATM396-18	GV-18	Plug	AS8-18
			Receptacle	AS9-18
20	ATM396-20	GV-20	Plug	AS8-20
			Receptacle	AS9-20
22	ATM396-22	GV-22	Plug	AS8-22
			Receptacle	AS9-22
24	ATM396-24	GV-24	Plug	AS8-24
			Receptacle	AS9-24

WIRE SIZES AND DIAMETERS

AUTOSPORT SIZE		FINISHED WIRE DIMENSIONS			
CONTACT SIZE	WIRE SIZE (AWG)	CONDUCTOR		INSULATION	
		MIN	MAX	MIN	MAX
24	30,28,26,24	0.254mm	0.511mm	0.56mm	1.02mm
		0.010in	0.02in	0.22in	0.040in
23	28,26,24,22	0.321mm	0.790mm	0.60mm	1.37mm
		.012in	.031in	.023in	.054in
22	26,24,22	0.405mm	0.790mm	0.76mm	1.37mm
		.015in	.031in	.030in	.054in
20	24,22,20	0.511mm	0.970mm	1.02mm	2.11mm
		.02in	.038in	.040in	.083in
16	20,18,16	0.812mm	1.530mm	1.65mm	2.77mm
		.031in	.60in	.65in	.109in

FILLER PLUGS

CONTACT SIZE	PART NUMBER
24	600300-24
23	600300-22
22	600300-22
20	600300-20
16	600300-16



Meeting the aspirations of a Global Market
www.deutsch.net



DEUTSCH AUTOSPORT DISTRIBUTION NETWORK

Contact your local distribution outlet for sales and further information.



AUSTRALIA

GR Motorsport Electrics
PTY Ltd
Unit 1, 9 Sherwood Court
Wantima South
Victoria 3152
Australia
Tel: +61 398 004900
Fax: +61 398 004911
Email: grmotorsportelectrics@bigpond.com



FRANCE

Davum TMC
Zac du Bois, Moussay - Bay Delta
30 Rue du Bois, Moussay
Paris
93240 Stains
France
Tel: +33 1483 68401
Fax: +33 1483 61462
Email: info@davumtmc.com



GERMANY

Compagnie Deutsch GmbH
Fraunhoferstrasse 11b
82152 Martinsreid
Germany
Tel: +49 89 8991570
Fax: +49 89 8574684
Email: info.eu@deutsch.net



ITALY

Deutsch Italia Srl
Viale E. Jenner, 51
20159 Milano
Italy
Tel: +39 02 393 22240
Fax: +39 02 376 1744
Email: info@deutsch-italia.it



DEUTSCH

AUTOSPORT



JAPAN

Global Active Technology
4-11-11, Higashitokorozawa
Tokorozawa-shi
Saitama 359-0021
Japan
Tel: +81 42 945 1515
Fax: +81 42 945 1555
Email: sales@gat.ne.jp



UNITED KINGDOM

Servo Interconnect Ltd
Stanier Road
St Leonards on Sea
East Sussex
TN38 9RF
United Kingdom
Tel: +44 (0) 1424 858350
Fax: +44 (0) 1424 858351
Email: sales@servo-il.co.uk



USA

IS Motorsport Inc
286a Gasoline Alley
Indianapolis
Indiana 46222
USA
Tel: +1 317 244 6643
Fax: +1 317 244 6693
Email: sales@ismotorsport.com



USA

Cosworth Electronics Inc
Suite 275
8250 Haverstick Road
Indianapolis
Indiana 46240
USA
Tel: +1 317 259 8900
Fax: +1 317 259 0137
Email: deutschsales@cosworth.com

Stanier Road, St Leonards on Sea
East Sussex TN38 9RF UK

Tel: +44 (0) 1424 852722

Fax: +44 (0) 1424 855979

Email: autosport@deutsch.net
www.deutsch.net

ASC 10769/01/08