

iTRACK

The intelligent track system

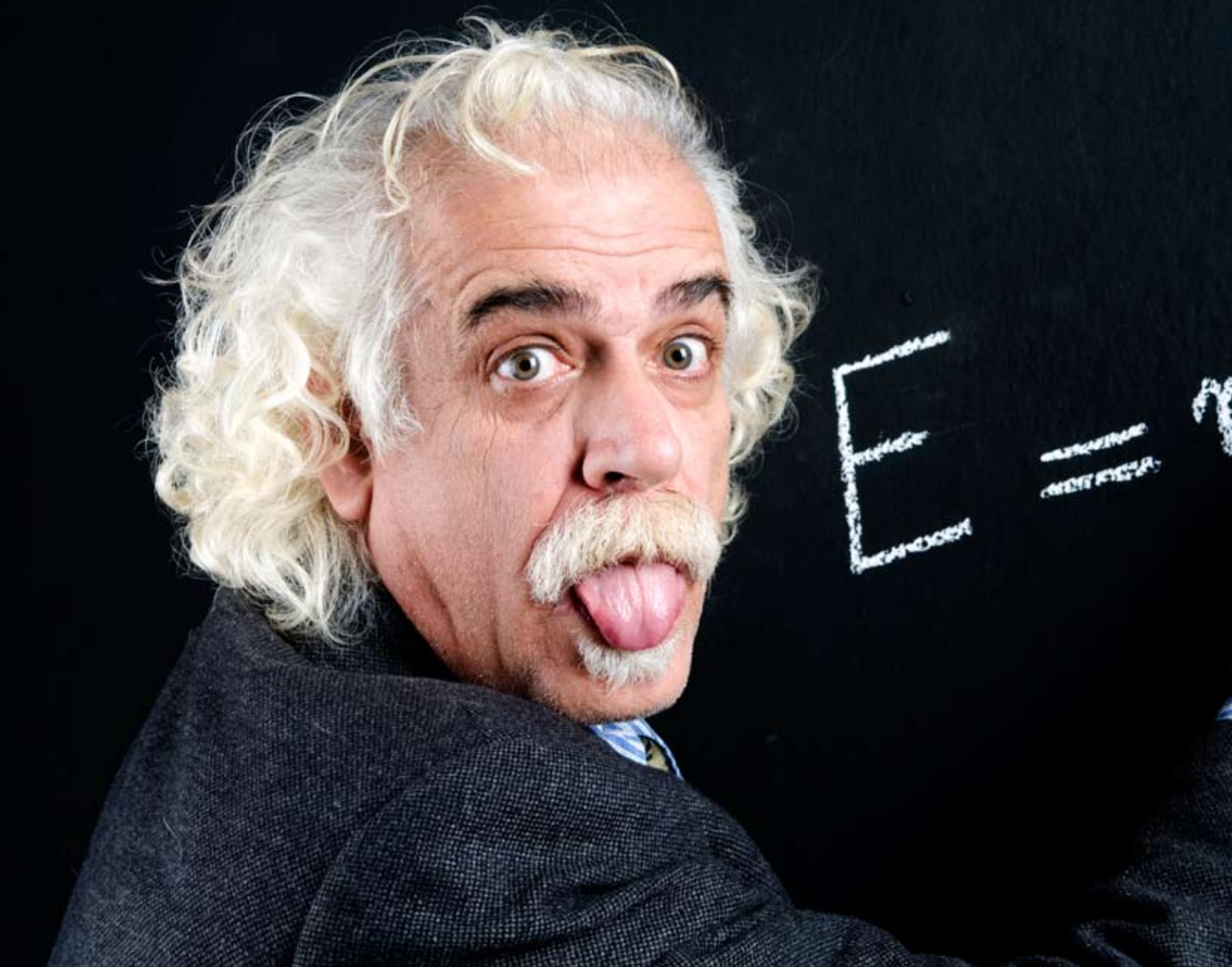

FAGERHULT



Simply intelligent

A track system is an ideal solution for large spaces where many luminaires have to work in unison. This level of functionality, unfortunately, often comes at a price. Complex and time intensive installation is a traditional characteristic of these solutions, where the slightest change easily transforms into an in-depth project. Limitations within the track systems of today often force a choice between functions and types of fixture. That's why Fagerhult developed iTrack; a system which refuses to compromise.



Simply complete

iTrack is a complete lighting system which unites luminaires, controls and emergency lighting on a single track solution. This inherent flexibility ensures energy efficient, future-proofed systems can be configured to complement the functions being undertaken within the space – in virtually any application.



Track

The track, with its twelve circuits forms the heart of the system. This advanced technical solution is concealed within a subtle white housing – contributing towards the visual appeal of the space.



Luminaires

iTrack can be equipped with a range of different fixtures, from the stringent industrial to aesthetic interiors there is a luminaire option for virtually any environment.



Connectors

A large number of different connectors further enhances the flexibility of the system. In addition to standard X, T, L and straight connectors there is a new flex connector – which is exclusive to iTrack.



Installation

Ease of installation was one of the driving forces behind the development of iTrack. Either surface mounted or suspended iTrack simplifies the process for a fast and attractive installation every time.



Control

Embracing the energy savings offered by lighting controls iTrack can be supplied with a range of different sensors, combining with other functions such as emergency lighting, for a complete and simple installation.



A single lighting system that addresses the needs of the entire project? Wishful thinking until now. iTrack makes what was impossible, possible.

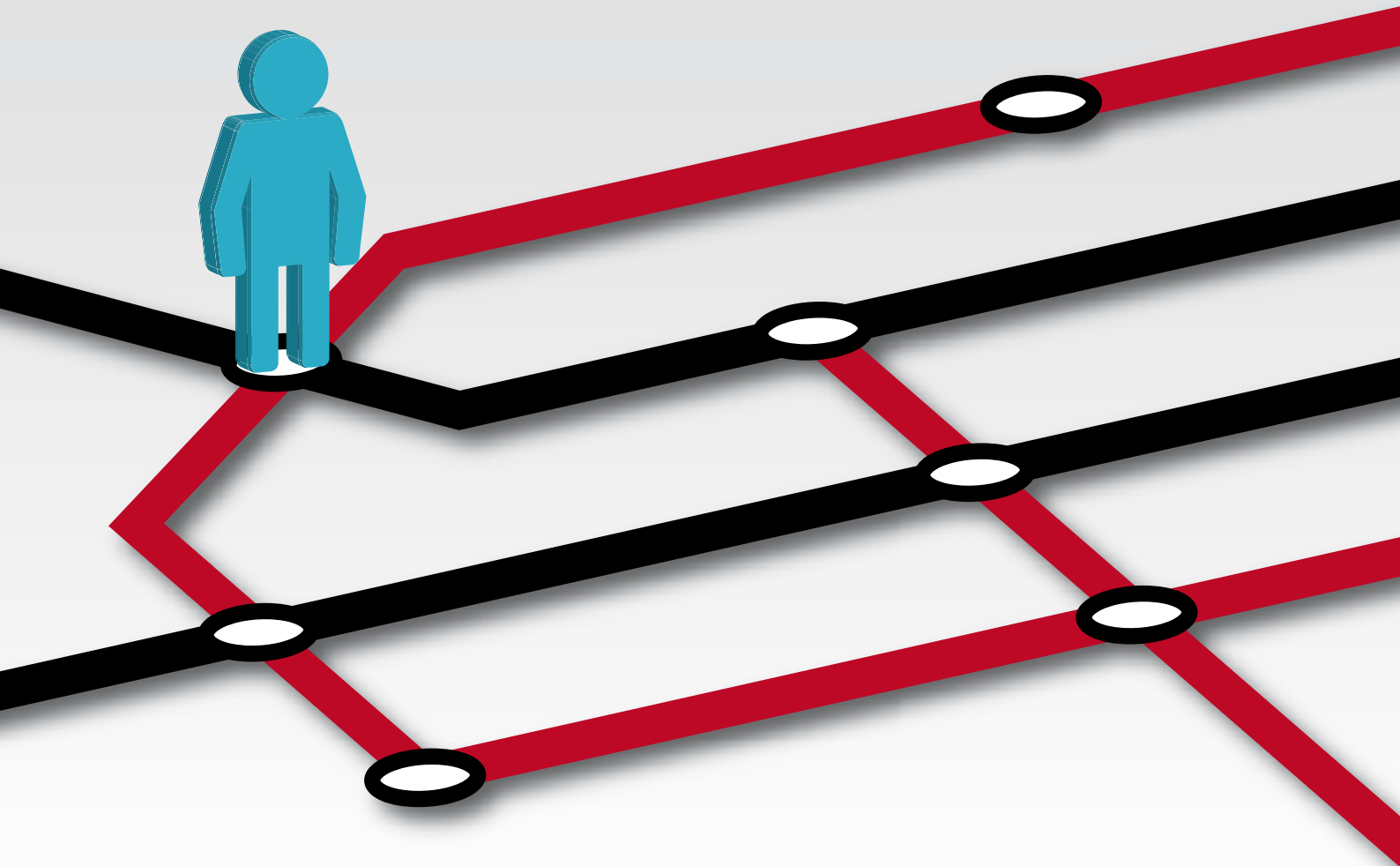

The flex factor

The ability to accommodate and compliment the design of a space is one of the most desirable features in a lighting system and iTrack boasts an unrivalled level of versatility. The track itself is available in four different lengths, with its host of connection options, offerings the scope to create dynamic systems free from traditional limitations.

The expected X, T and L couplers are enhanced by iTrack's flex-connector which can be horizontally or vertically angled up to 135°. Traditional problems of finding a solution which can be used throughout a building, regardless of varying ceiling angles, is now a thing of the past; offering synergies which benefit the design, installation and maintenance of a project.

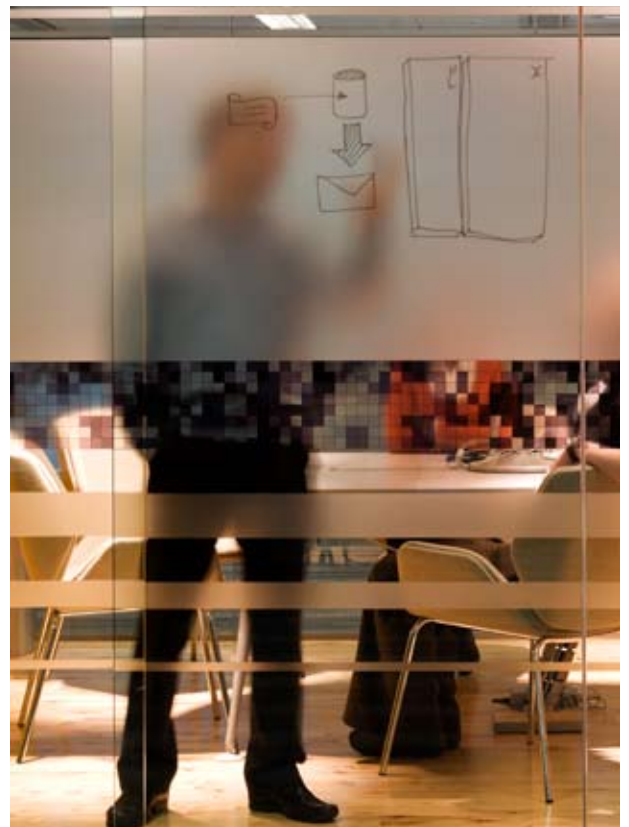



Engineered for value

Product development at Fagerhult takes a holistic view of value, from design and installation through to operation and maintenance we produce systems which offer a cost effective solution throughout the life-cycle of a project.

The concept behind iTrack was developed from scratch, offering a fresh perspective on the functionality and technology available to offer cost efficiency in every area. The performance of an iTrack scheme is determined by the selected configuration and choice of luminaires. Fagerhult's Life Cycle Cost calculator, LCC, helps identify at the planning stage an accurate picture of the costs throughout the lifecycle of a project. The LCC is available to download at www.fagerhult.com.

Planning and installation

A wide range of intelligent accessories simplifies the design process, offering the scope to create the right solution for the specific project requirements without compromise.

iTrack can quickly and easily be rebuilt, facilitating adjustments to the positioning of the luminaires should the layout or usage of the space change.

Energy efficiency

The choice of light source is a key consideration when designing energy efficient luminaires, that is why iTrack was developed to utilise the two most efficient sources on the market; LED and T5. With this as the foundation iTrack can offer further energy savings through the use of control.

A presence sensor which detects the occupancy in a space, and switches the light on or off accordingly, can significantly reduce the energy consumed across a range of applications including corridors, schools and offices. Daylight sensors work in unison with natural daylight, regulating the level of light to ensure suitable luminance levels are achieved while minimising the consumption of energy.

Expect more

Twelve circuits of built-in flexibility

A longstanding limitation of track systems has been the number of circuits; often placing limitations on the number of functions which can be used simultaneously. iTrack is supplied with 12 built in circuits more than any other system on the market offering the freedom to access three different phases for luminaires, in addition to emergency and lighting control. Use 3, 7, 8 or 12 circuits depending on your requirements, now you never need to compromise in your selection. This advanced technical solution has not been achieved at the expense of aesthetics. Its compact design and clean lines are manufactured of extruded aluminium, creating a lighter solution than the traditional track systems constructed of steel.

Four circuits of openness

iTrack was developed to accommodate 3-phase adaptors, creating a unique open system. The ability to select virtually any spotlight offers the designer greater freedom to choose the lighting solutions they want from across the market. Should the positioning of the furniture or activities being undertaken within the space change, the installed iTrack system can be easily and quickly adapted accordingly.



All connections are made in the supply connector before it is connected to the track.



iTrack's 'openness' is unique and provides an opportunity to mount spotlights from any manufacturer anywhere along the track

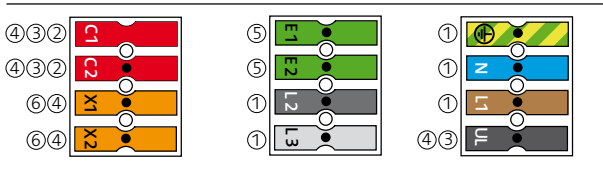
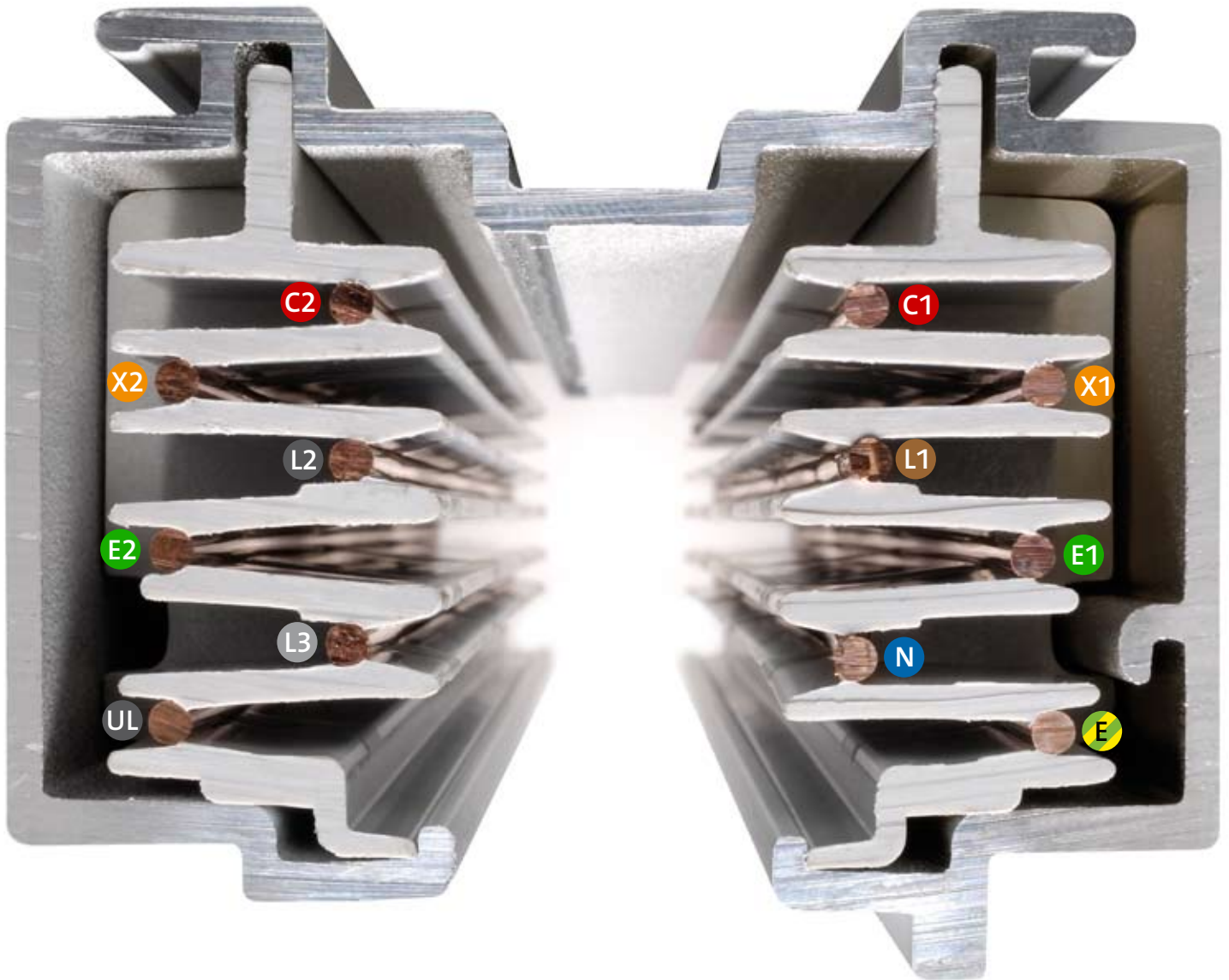

- ① 400 V
- ① + ② 400 V+dim (DALI, 1–63 addresses)
- ① + ③ 400 V+dim (DALI, 1–63 addresses)+decentralised emergency lighting
- ① + ④ (DALI, 1–63 addresses)+decentralised emergency lighting and monitoring
- ① + ⑤ 400 V+centralised emergency lighting
- ① + ⑥ 400 V+dim (DALI, 64–126 addresses)

Diagram of connections in the connection unit with different types of lighting installations.

Explanation:

E – Earth.
UL – Unbroken cable.
N – Neutral.
L1, L2 and L3 – phases.
C1 and C2 – are used as control cable for e.g. DALI (address 1–63).
X1 and X2 – are used for e.g. DALI (address 64–126) or monitoring with decentralised emergency lighting.
E1 and E2 – are used for operation of centralised emergency lighting.
N, L1, L2 and L3 are used with the connection of e.g. a Multi-adapter XTSA 68 at the same time as the adapter is earthed to the top edge of the track.



Four circuits for control

iTrack is designed to incorporate the functions of contemporary lighting control; compatible with most of the market's leading suppliers. iTrack has been optimised for DALI to maximise the fully capabilities of the system. The addressable DALI control simplifies the process of coordinating numerous luminaires digitally, without the need for manual intervention. From presence sensors to daylight control iTrack creates an ideal lit environment while keeping energy expenditure to a minimum.

Double up

Today the DALI protocol is used to create flexible, digital control solutions for fluorescent lighting. The system presents numerous opportunities to programme customisable controls, however existing installations are limited by the number of addresses (64). The standard 7-pole iTrack can be delivered with up to 63 addresses, while the twelve pole version has two DALI systems working in unison. The first DALI connection (C1/C2) and the second connection (X1/X2) offering the scope to control almost twice as many fixtures within the same track system.

The second circuit (X1/X2) is connected to a DALI router ensuring full compatibility between the two systems offering twice the capabilities of a standard offering. By offering additional features, such as push button panels and touch screens the full capabilities of the system can be accessed in a user-friendly fashion.

Four circuits for safety

Emergency lighting is an essential requirement for modern track systems. iTrack can be configured for both decentralised and centralised emergency systems. Fagerhult's emLED emergency lighting range offers both options. Both utilise the ultra efficient LED light source while the decentralised version is equipped with a NiMHA battery as part of its environmentally conscious design. The fourth conductor is an earth wire, which ensures earth continuity between the rails, past the links and joints.

emLED decentralised

The integrated emLED system is directly connected to iTrack. The system includes electronics, battery and a LED unit that provides emergency lights for three hours. The system corresponds to the requirements of EN 60598-2-22 and has a built-in self-test according to EN 62034. In iTrack with DALI, each emergency unit can be monitored or tested through the DALI protocol, which makes the system ideal for retail spaces, schools and offices.

emLED centralised

The centralised emLED system is based on an integrated LED unit that connects to the central emergency lighting system.



Industrial premises with LED-based emergency lighting.



emLED mounted directly on iTrack.

The right light for now – and the future

With the practical and technical considerations of a track system often coming to the fore at the design stage, it's amazing how often the actual lighting solutions itself ends up being a secondary concern. iTrack has been developed in the Fagerhult spirit of focusing on enhancing the visual tasks and the experience within a room.

A prerequisite for a track system is that the light can be adjusted to the needs of the room and with the scope to reinvent itself over time. An open plan office can often become a collection of cellular ones; the fact that a premises and its use varies over time is the rule not the exception. A lighting solution should be considered a long-term investment and accommodating of change. iTrack can be easily rebuilt and extended to adapt to new needs.

The luminaires in the iTrack family are suitable for a diverse range of applications. Should the activities undertaken change, it is easy to rebuild or replace. A truly future-proofed solution!

iTrack Line, available in 1-lamp and 2-lamps variations with or without reflectors. Add lamell louvre or end caps, or both. Continuous mounting with reflector springs provides invisible seams and makes it possible to build long, brilliant lines.



All fixtures are connected to the track via the adaptor. The phase selector lets you select which phase the luminaire is connected to. The luminaire is fixed to the track by the means of a lock at each end of the luminaire.

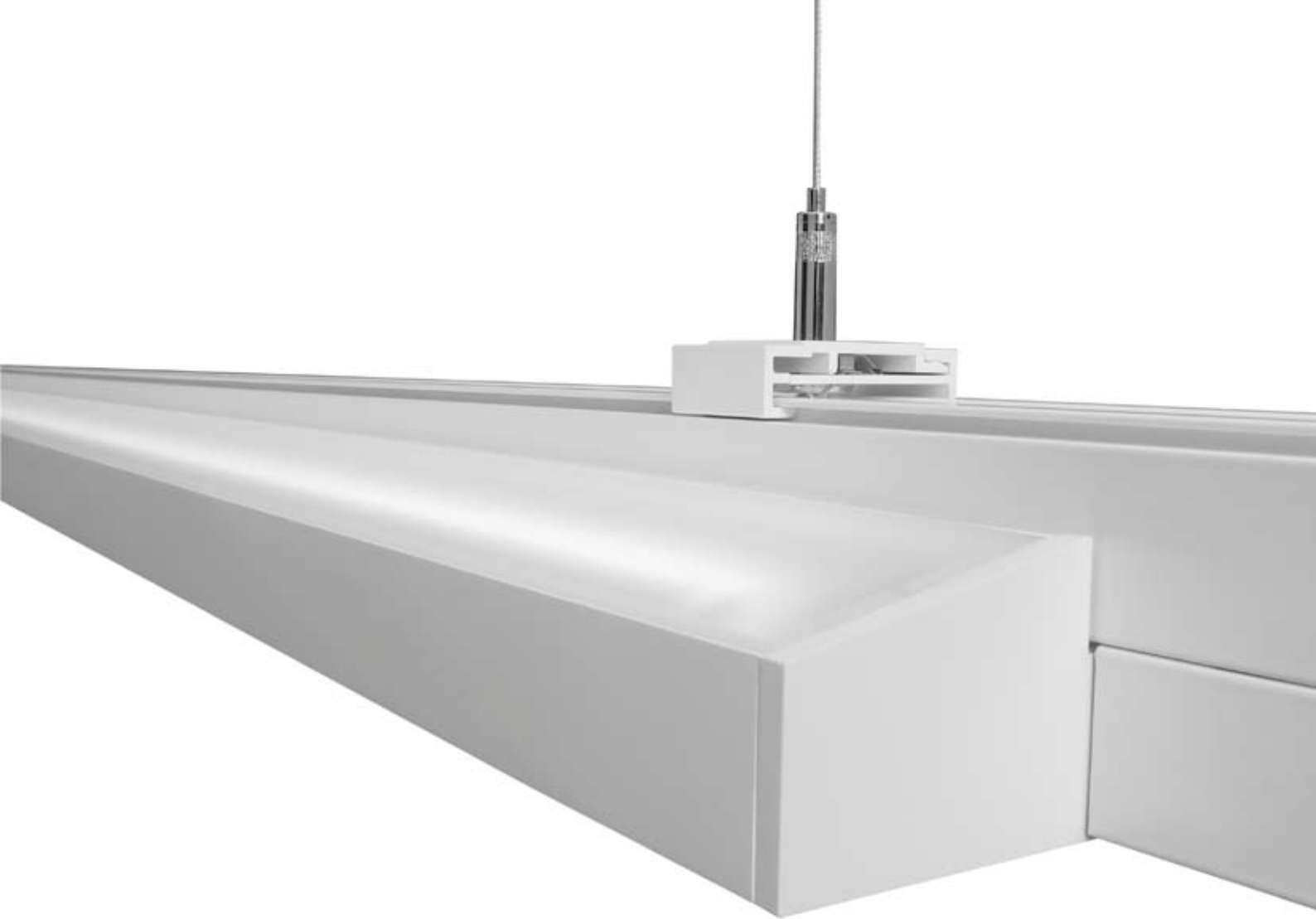

iTrack Dual, 2-lamp with direct/indirect light distribution. Beta or Delta louvre. The solution provides a certain percentage of uplight, helping to illuminate the ceiling.



iTrack Kite, 1-lamp with direct light distribution. Beta or Delta louvre. The large bright surface provides a softly diffused and comfortable light.

0–500 lux in 15 minutes

The costs associated with installations are an important part of the investment in a new track system. iTrack has been developed for easy and logical installation, helping to reduce valuable time on site and reduce the risk of errors made during the connections.

The various couplers connect the contacts between the circuits and compliment the profiles slim dimensions for a virtually seamless join between the track lengths. Each

adaptor has a switchable phase selector, which further facilitates installation.

The luminaires are easily placed in the desired location along the track via a quick lock, which makes the electrical connection with the adapter. Ongoing maintenance is simplified as each luminaire can be connected, or disconnected, without impacting on the other luminaires within the space.



00:00 An empty room with all iTrack-parts unpacked and ready to be installed.

02:42 Wire suspension mounted on the ceiling. Pendant bracket can slide freely on the wire.



09:12 iTrack is easily attached to the pendant bracket and the second track length is assembled and secured with a screw fastener.

12:52 The luminaires are connected to the rail.

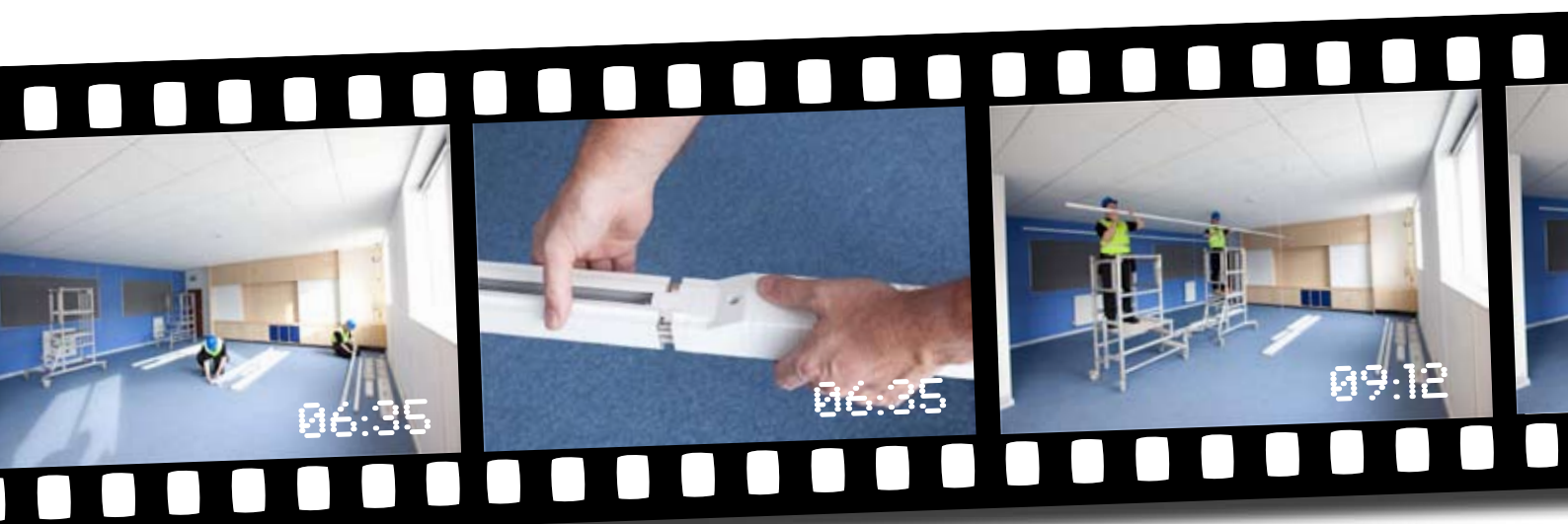

06:35 Supply-connector and I-joints installed in the rail and fixed with a screw fastener.

09:12 The track is completely assembled and ready to hang in pendant brackets to the ceiling.



12:52 The luminaires are affixed to the track by means of quick lock.

14:15 The supply-connectors are connected to power.

15:00 Installation is complete in 15 minutes.



Customised solutions for every application

With its uncompromising functionality iTrack is a system which opens up new possibilities in lighting design. The slim profile conceals the technical elements from view while the variation within the range offers a solution for the most diverse of applications.

The ability for track systems to permit numerous luminaires to communicate and act in unison lends itself to large areas or longer spaces. From airports and warehouses to factories and showrooms there is an option within the iTrack family for virtually any environment.

Offices

The ability to reconfigure the lighting system as the interior changes makes iTrack ideal for a host of commercial applications. In call centres or large open plan office, both which are subject to regular reinventions, fixtures can be easily removed or replaced without causing major disruptions to the operations. Fagerhult's Dual and Kite luminaires offer a choice between either a totally direct light distribution or a combination of direct and indirect. Both are equipped with the high performance Beta louvre, safeguarding against glare and helping to create a comfortable working environment. Supplementing the system with presence or daylight controls helps keep the energy consumption to a minimum while a DALI system can programme the luminaires for either preset scenes or a user defined level for a personal lighting experience.

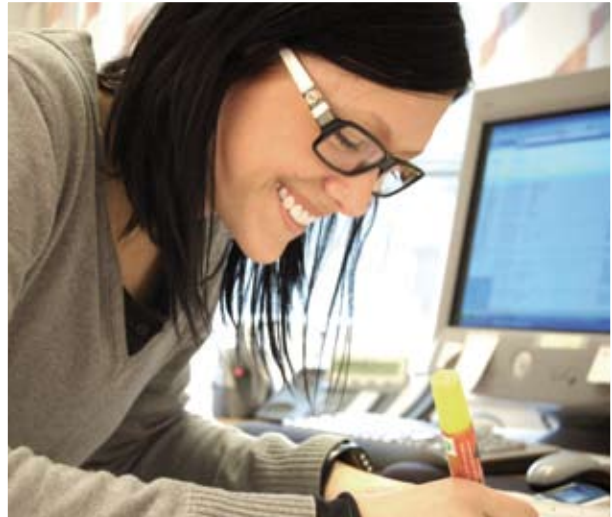



Venues

iTrack's ability to combine large-scale lighting solutions with controls and emergency lighting lends itself perfectly to rooms where many people gather – such as conference centres and schools. With a DALI control system you can create specific lighting scenes for different types of activities such as meetings, presentations and performances. iTrack Dual is an ideal solution for conference halls or classrooms, where its combination of direct and indirect lighting provides a comfortable environment that facilitates communication and learning.

Presence and daylight control is an effective way of ensuring energy is not wasted in these types of premises with irregular usage patterns.



Industry

Easy maintenance, good lighting performance and a robust design, iTrack ticks every box of the essentials of lighting in industrial environments. The system is quick to install and be maintained or rebuilt with minimal disruption to ongoing production. Providing an effective working light, the addition of controls offers the scope to optimise the light levels to the different requirements of shift work. The sturdy design of the luminaires and connections creates a durable, longlife alternative to more traditional industrial fixtures.





Showrooms

The iTrack system can be designed to discretely follow the shape of the room, characteristics well suited to the requirements of exhibition halls or showrooms. The open nature of the systems offers the freedom to select spotlights from across the marketplace which can be grouped together by DALI controls to intelligently adapt the light levels as the exhibition is changing.



Retail

With evolving displays the world of retail moves fast and iTrack has the ingrained flexibility needed to react. iTrack's luminaires can be simply and quickly re-positioned, or replaced to accommodate and accentuate not only changes to the layout but also the products on display. Luminaires for general lighting can be complemented by the choice of virtually any spotlight, drawing attention and showing merchandise in the best possible light. The system can easily be varied based on any concept while maintaining a unified visual theme throughout the store.



One luminaire for each task

iTrack is accompanied by a complete range of fittings. Based on the efficiency of the T5 light source there are options for both general and accent lighting, tailored to optimise the system's functions. With one eye firmly on emerging technologies, iTrack was developed to accommodate the future addition of luminaires with a LED lightsource, a capacity already utilised in the emergency range. As standard all fixtures are supplied with adapters for easy installation.

iTrack Line

1–6. Line is the basic luminaire in the system, developed to provide efficient and pleasant general lighting levels. Available with several different light distributions, with or without a reflector and in a 1 or 2 lamp design, Line is well suited to a range of different lighting applications. The luminaire can additionally be supplied with end caps and a Lamell louvre as an accessory.

iTrack Dual

7–8. Dual combines direct and indirect light for a more varied lit environment. The light is spread across both sides of the track while the indirect light on the ceiling provides an enhanced spatial experience. A compact and minimalist design contributes towards its subtle expression. Dual is easy to install and with excellent access for maintenance. Available with either Beta or Delta louvre.

iTrack Kite

9–10. Kite combines advanced technical performance with a striking light experience. Its distinctive profile and sharp angles are complemented by the combinations of louvers helping to enhance its aesthetic qualities. The central louvre is flanked by opal surfaces which produce a soft, diffuse light. Available with either Beta or Delta louvre.

iTrack emLED

11. Fagerhults own emergency lighting, emLED, is easily and discreetly connected to the track system. The LED-based system is functional and maintenance free. Emergency lighting is self-sufficient, self testing to EN 62034 and can be integrated with other luminaires within the system.

Spotlights

12. A Multi-adapter opens the system, offering the freedom to choose from either the selection of Fagerhult spotlights or any other alternatives in the market.



Connectors

No track systems can be regarded as complete unless it offers benefits in flexibility and economy. iTrack's connectors were developed to facilitate easy and quick installation, while the depth of the selection helps simplify the design process.

Track

1. From short one-meter to long four-meter tracks; with a standard offering boasting four different sizes time-consuming length adjustments are kept to a minimum.

Connection

2. It is as simple as fixing a plug and it can even be assembled on the floor. An easy, quick and cost saving approach to installation.

Connectors

3–7. Left or right? Cross- or T-connectors? Straight or a slight curve, sideways or vertical? Push in and tighten with a screwdriver. It is always that simple.

Control

8. A neat little device that directly provides an on/off function without additional programming. The system can be custom commissioned for full DALI capabilities on demand.

Installation

9–10. A smart bracket grips the rail when pressed without the need for tools. Suspended or directly into the ceiling? Both are connected just as easily.





iTrack

Track system

Installation

Surface mounted with a ceiling bracket or suspended from a wire pendent bracket, see the installation accessories.

Connection

In a connection unit, see coupling accessories.

Design

White finished extruded aluminium (RAL 9016) with polycarbonate isolation profile. All conductors and earth conductor of 2.5 mm copper. 400 V, 3x16 A. IP 20.

Dimming

iTrack can easily be equipped with a multisensor for constant light, occupancy detection and receiver for a remote control (IR), see accessories. The functionality requires luminaires with DALI (-368) and a connected power supply unit.

Adapter

Luminaires connected to the track require iTrack's special adapter. Luminaires are mechanically locked to the track via a fastener on the adapter. Adapters are also equipped with a phase selector for phase 1, 2 or 3. Luminaires supplied with a phase selector are set to phase 1. Spotlights with Multi-adapter XTSA 68 can be connected.

Track	
mm	
1000	78200
2000	78201
3000	78202
4000	78203

See pg. 30–31 for coupling and connection accessories.

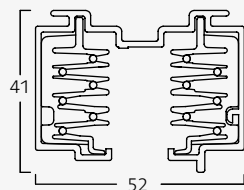

Connection unit 78220 is fitted to the end of the track.



The track is installed via a ceiling bracket 78248.



iTrack Kite

Installation

Connected to Fagerhult's iTrack via a special 7-way adapter.

Design

Luminaire body of white extruded aluminium in white enamelled finish (RAL 9016) with polycarbonate end-caps and opalised, polycarbonate side diffusers

Louvre

Beta – double parabolic with satin matt metallised aluminium side and cross blades with excellent reflection characteristics (> 92 %).

Delta – diffused microprism in acrylic TPb (PMMA) with good optical characteristics.

Emergency lighting

Most variants can be equipped with emergency lighting (-160).

Dimming

iTrack can be equipped with a multisensor for constant light, occupancy detection and receiver for a remote control (IR), see accessories. The functionality requires luminaires with DALI (-368). iTrack Kite can be equipped with other ballasts for dimming on request.

Miscellaneous

The luminaires are supplied with a phase selector set to phase 1. Some variations may require a 12-way adapter configured to suit.

Installation via iTrack's 7-way adapter (Earth, L1, L2, L3, N, C1, C2)

FDH	kg		
Beta			
1x25/28	4.5	27900	■
1x32/35	4.9	27902	■
1x45/49	4.9	27903	■
1x50/54	4.5	27901	■
Delta			
1x25/28	4.5	27910	■
1x32/35	4.9	27912	■
1x45/49	4.9	27913	■
1x50/54	4.5	27911	■

Suffix code

■ -368 DALI (address 1–63)

Add suffix code to the end of the luminaire part number to indicate required function.

Accessories

iTrack cover 1200 mm	27997
iTrack cover 1500 mm	27998

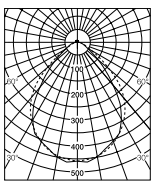

Beta

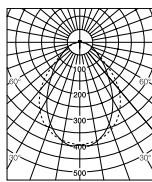

Delta

	A
1x25/28/50/54 W	1185
1x32/35/45/49 W	1485

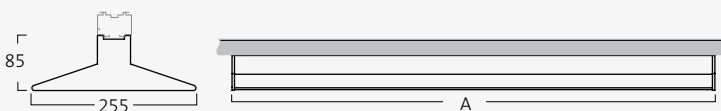

Track Kite is also available with a Delta louvre of acrylic plastic.



iTrack Dual

Installation

Connected to Fagerhult's iTrack via a special 7-way adapter.

Design

Luminaire body of white extruded aluminium in white enamelled finish (RAL 9016) with polycarbonate end caps.

Louvre

Beta – double parabolic with satin matt metallised aluminium side and cross blades with excellent reflection characteristics (> 92 %).

Delta – diffused microprism in acrylic TPb (Pmma) with good optical characteristics.

Emergency lighting

Most variants can be equipped with emergency lighting (-160).

Dimming

iTrack can be equipped with a multisensor for constant light, occupancy detection and receiver for a remote control (IR), see accessories. The functionality requires luminaires with DALI (-368). iTrack Dual can be equipped with other ballasts for dimming on request.

Miscellaneous

The luminaires are supplied with a phase selector set to phase 1. Some variations may require a 12-way adapter configured to suit.

Installation via iTrack's 7-way adapter (Earth, L1, L2, L3, N, C1, C2)

FDH

Beta	kg		
2x25/28	3.9	27920	■
2x32/35	4.4	27922	■
2x45/49	4.4	27923	■
2x50/54	3.9	27921	■
Delta			
2x25/28	3.9	27930	■
2x32/35	4.4	27932	■
2x45/49	4.4	27933	■
2x50/54	3.9	27931	■

Suffix code

■ -368 DALI (address 1–63)

Add suffix code to the end of the luminaire part number to indicate required function.

Accessories

Track cover 1200 mm	27997
Track cover 1500 mm	27998

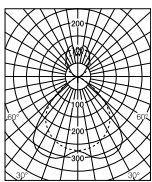

Beta

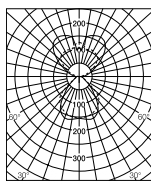

Delta

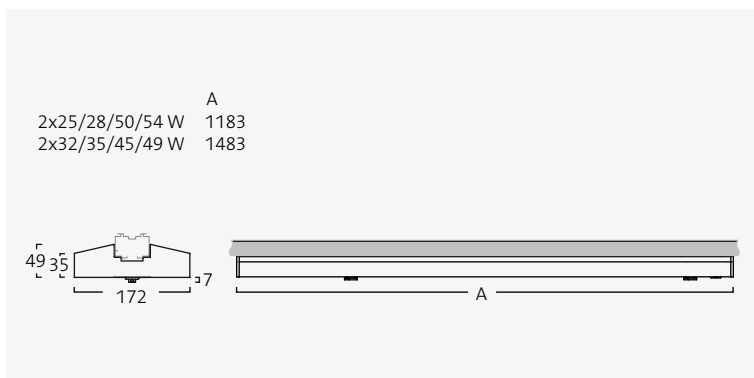

iTrack Dual with a Delta microprism louvre.



The opening for indirect light is covered by an acrylic plastic diffuser.



iTrack Line

Installation

Connected to Fagerhult's iTrack via a special 7-way adapter.

Design

Luminaire body of white extruded aluminium in white enamelled finish (RAL 9016) with polycarbonate end caps.

Emergency lighting

Most variants can be equipped with emergency lighting (-160).

Dimming

iTrack can be equipped with a multisensor for constant light, occupancy detection and receiver for a remote control (IR), see accessories. This functionality requires luminaires with DALI (-368). iTrack Line can be equipped with other ballasts for dimming on request.

Miscellaneous

The luminaires are supplied with a phase selector set to phase 1. Some variations may require a 12-way adapter configured to suit.

Installation via iTrack's 7-way adapter (Earth, L1, L2, L3, N, C1, C2)				
FDH	kg			
1x25/28	1.6		34900	■
1x32/35	2.0		34901	■
1x45/49	2.0		34902	■
1x50/54	1.6		34903	■
1x73/80	2.0		34904	■
2x25/28	1.7		34907	■
2x32/35	2.2		34908	■
2x45/49	2.2		34909	■
2x50/54	1.7		34910	■
2x73/80	2.2		34911	■

Suffix code
 ■ -368 DALI (address 1–63)
 Add suffix code to the end of the luminaire part number to indicate required function.

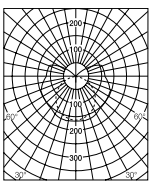

1x32/35,
without reflector

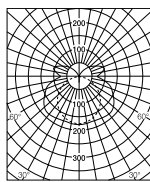

2x32/35,
without reflector

W	A	B	C ¹	C ²
25/28/50/54	1172	52	74	110
32/35/45/49/73/80	1472	52	74	110



iTrack Line in a 2-lamp design.



iTrack Line is supplied with 7-way adapter.



iTrack Line

Wide beam

Installation

Connected to Fagerhult's iTrack via a special 7-way adapter.

Design

Luminaire body of sheet steel in a white enamelled finish (RAL 9016) with polycarbonate end caps.

Louvre

Lamell – white enamelled cross-blade, steel louvre. Available in two designs, one for reflectors with end cap/caps and one for reflectors without end caps.

Reflector

Wide beam symmetrical light distribution of satin matt metallised aluminium with very good reflection characteristics (> 92 %).

Emergency lighting

Most variants can be equipped with emergency lighting (-160).

Dimming

iTrack can be equipped with a multisensor for constant light, occupancy detection and receiver for a remote control (IR), see accessories. The functionality requires luminaires with DALI (-368). iTrack Line can be equipped with other ballasts for dimming on request.

Accessories

Reflector end caps of polycarbonate. Joint springs for continuous installation of metallised aluminium. Installed between reflectors.

Miscellaneous

The luminaires are supplied with a phase selector set to phase 1. Some variations may require a 12-way adapter configured to suit.

Installation via iTrack's 7-way adapter (Earth, L1, L2, L3, N, C1, C2)

FDH	kg		
1x25/28	1.9	34820	■
1x32/35	2.4	34821	■
1x45/49	2.4	34822	■
1x50/54	1.9	34823	■
1x73/80	2.4	34824	■
2x25/28	2.0	34827	■
2x32/35	2.6	34828	■
2x45/49	2.6	34829	■
2x50/54	2.0	34830	■
2x73/80	2.6	34831	■

Suffix code

■ -368 DALI (address 1–63)

Add suffix code to the end of the luminaire part number to indicate required function.

Accessories

Lamell louvre for reflector with end cap, 25/28/50/54	89400
Lamell louvre for reflector with end cap, 32/35/45/49/73/80	89402
Lamell louvre for reflector without end cap, 25/28/50/54	89401
Lamell louvre for reflector without end cap, 32/35/45/49/73/80	89403
Reflector end caps, pair	92635
Reflector joint springs	92630

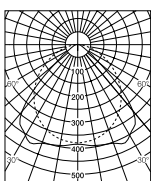

1x32/35

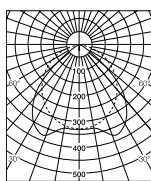

2x32/35

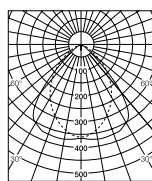

1x32/35, lamell

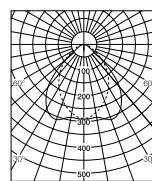

2x32/35, lamell

W	A	B	C ¹	C ²
25/28/50/54	1172	100	102	138
32/35/45/49/73/80	1472	100	102	138

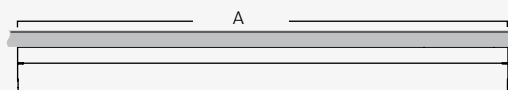
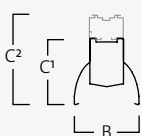

Joint springs are easily fitted between the reflectors in a continuous installation.



iTrack Line wide beam can be equipped with end caps.



iTrack Line

Medium beam

Installation

Connected to Fagerhult's iTrack via a special 7-way adapter.

Design

Luminaire body of sheet steel in a white enamelled finish (RAL 9016) with polycarbonate end caps.

Louvre

Lamell – white enamelled cross-blade, steel louvre.

Available in two designs; one for reflectors with end caps and one for reflectors without end caps.

Reflector

Medium beam symmetrical light distribution of satin matt metallised aluminium with very good reflection characteristics (> 92 %).

Emergency lighting

Most variants can be equipped with emergency lighting (-160).

Dimming

iTrack can be equipped with a multisensor for constant light, occupancy detection and receiver for a remote control (IR), see accessories. The functionality requires luminaires with DALI (-368). iTrack Line can be equipped with other ballasts for dimming on request.

Accessories

Reflector end caps of polycarbonate. Joint springs for continuous installation of metallised aluminium. Installed between reflectors.

Miscellaneous

The luminaires are supplied with a phase selector set to phase 1. Some variations may require a 12-way adapter configured to suit.

Installation via iTrack's 7-way adapter (Earth, L1, L2, L3, N, C1, C2)

FDH	kg		
1x25/28	1.9	34840	■
1x32/35	2.5	34841	■
1x45/49	2.5	34842	■
1x50/54	1.9	34843	■
1x73/80	2.5	34844	■
2x25/28	2.1	34847	■
2x32/35	2.7	34848	■
2x45/49	2.7	34849	■
2x50/54	2.1	34850	■
2x73/80	2.7	34851	■

Suffix code

■ -368 DALI (address 1–63)

Add suffix code to the end of the luminaire part number to indicate required function.

Accessories

Lamell louvre for reflector with end cap, 25/28/50/54	89412
Lamell louvre for reflector with end cap, 32/35/45/49/73/80	89413
Lamell louvre for reflector without end cap, 25/28/50/54	89414
Lamell louvre for reflector without end cap, 32/35/45/49/73/80	89415
Reflector end caps, pair	92636
Reflector joint springs	92631

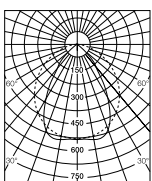

1x32/35

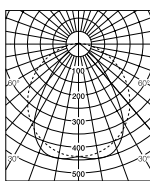

2x32/35

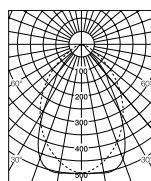

1x32/35, lamell

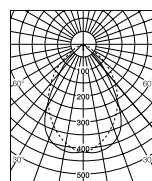

2x32/35, lamell

W	A	B	C ¹	C ²
25/28/50/54	1172	131	111	147
32/35/45/49/73/80	1472	131	111	147



The louvre is locked into position with springs, facilitating an easy installation.



The design of the springs and louvre provides an unbroken appearance when installed in continuous runs.



iTrack Line

Narrow beam

Installation

Connected to Fagerhult's iTrack via a special 7-way adapter.

Design

Luminaire body of sheet steel in a white enamelled finish (RAL 9016) with polycarbonate end caps.

Reflector

Narrow beam symmetrical light distribution of satin matt metallised aluminium with very good reflection characteristics (> 92 %).

Emergency lighting

Most variants can be equipped with emergency lighting (-160).

Dimming

iTrack can be equipped with a multisensor for constant light, occupancy detection and receiver for a remote control (IR), see accessories. The functionality requires luminaires with DALI (-368). iTrack Line can be equipped with other ballasts for dimming on request.

Accessories

Reflector end caps of polycarbonate. Joint springs for continuous installation of metallised aluminium. Installed between reflectors

Miscellaneous

The luminaires are supplied with a phase selector set to phase 1. Some variations may require a 12-way adapter configured to suit.

Installation via iTrack's 7-way adapter (Earth, L1, L2, L3, N, C1, C2)

FDH	kg		
1x25/28	1.9	34860	■
1x32/35	2.5	34861	■
1x45/49	2.5	34862	■
1x50/54	1.9	34863	■
1x73/80	2.5	34864	■
2x25/28	2.1	34867	■
2x32/35	2.7	34868	■
2x45/49	2.7	34869	■
2x50/54	2.1	34870	■
2x73/80	2.7	34871	■

Suffix code

■ -368 DALI (address 1-63)

Add suffix code to the end of the luminaire part number to indicate required function.

Accessories

Reflector end caps, pair	92637
Reflector joint springs	92632

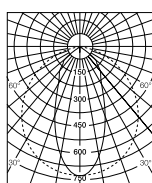

1x32/35

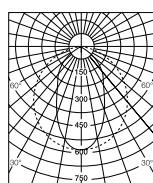

2x32/35

W	A	B	C ¹	C ²
25/28/50/54	1172	151	105	141
32/35/45/49/73/80	1472	151	105	141



iTrack luminaires are locked to the track without the need of additional tools.



The selector function determines which phase will power the luminaire.



iTrack Line

Asymmetrical

Installation

Connected to Fagerhult's iTrack via a special 7-way adapter.

Design

Luminaire body of sheet steel in white enameled finish (RAL 9016) with polycarbonate end caps.

Louvre

Lamell – white enameled cross-blade, aluminium louvre. Available in two designs, one for reflectors with end cap/caps and one for reflectors without end caps.

Reflector

Asymmetrical light distribution of satin matt metallised aluminium with very good reflection characteristics (> 92 %).

Emergency lighting

Most variants can be equipped with emergency lighting (-160).

Dimming

iTrack can be equipped with a multisensor for constant light, occupancy detection and receiver for a remote control (IR), see accessories. The functionality requires luminaires with DALI (-368). iTrack Line can be equipped with other ballasts for dimming on request.

Accessories

Reflector end caps of polycarbonate. Joint springs for continuous installation of metallised aluminium. Installed between reflectors.

Miscellaneous

The luminaires are supplied with a phase selector set to phase 1. Some variations may require a 12-way adapter configured to suit.

Installation via iTrack's 7-way adapter (Earth, L1, L2, L3, N, C1, C2)

FDH	kg		
1x25/28	2.0	34880	■
1x32/35	2.5	34881	■
1x45/49	2.5	34882	■
1x50/54	2.0	34883	■
1x73/80	2.5	34884	■
2x25/28	2.1	34887	■
2x32/35	2.7	34888	■
2x45/49	2.7	34889	■
2x50/54	2.1	34890	■
2x73/80	2.7	34891	■

Suffix code

■ -368 DALI (address 1–63)

Add suffix code to the end of the luminaire part number to indicate required function.

Accessories

Lamell louvre for reflector with end cap, 25/28/50/54	89408
Lamell louvre for reflector with end cap, 32/35/45/49/73/80	89410
Lamell louvre for reflector without end cap, 25/28/50/54	89409
Lamell louvre for reflector without end cap, 32/35/45/49/73/80	89411
Reflector end caps, pair	92638
Reflector joint springs	92633

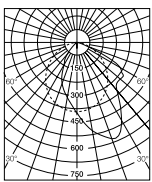

1x32/35

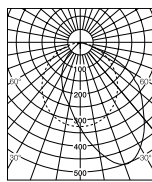

2x32/35

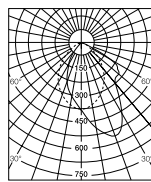

1x32/35, lamell

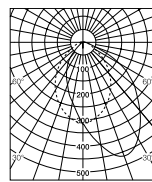

2x32/35, lamell

W	A	B	C ¹	C ²
25/28/50/54	1172	156	102	138
32/35/45/49/73/80	1472	156	102	138

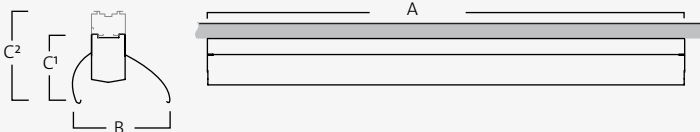

Optional end caps create an elegant appearance.

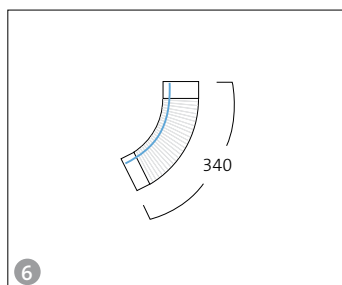
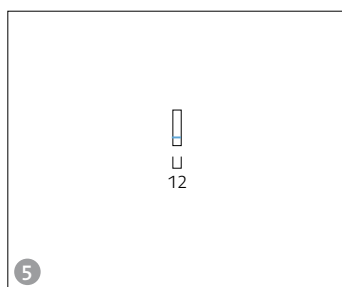
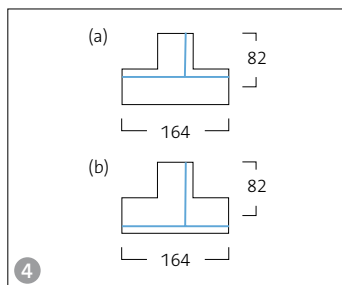
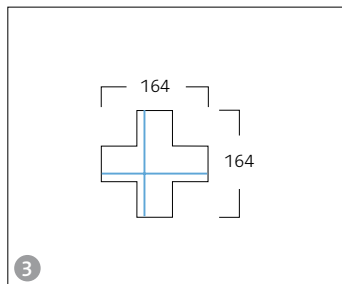
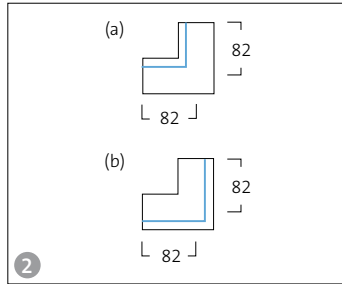
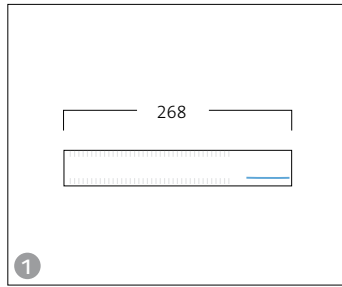

iTrack

Accessories

Connection devices

1. Connection device with three snap-in terminal blocks 4x1.5 mm². The connection device has an outer casing in white polycarbonate (RAL 9016).

Connection device	78220
-------------------	-------

2. L-coupler for connecting two tracks, the L-coupler has an outer casing in white polycarbonate (RAL 9016).

L-coupler, (a)	78222
L-coupler, (b)	78223

3. X-coupler for joining two tracks. The X-coupler has an outer casing in white polycarbonate (RAL 9016).

X-coupler	78226
-----------	-------

4. T-coupler for connecting two tracks, the T-coupler has an outer casing in white polycarbonate (RAL 9016).

T-coupler, (a)	78224
T-coupler, (b)	78225

5. I-coupler for joining two tracks. The I-coupler has an outer casing of white polycarbonate (RAL 9016).

I-coupler	78221
-----------	-------

6. Flexible coupler for joining two tracks. The flexible coupler has an outer casing of white polycarbonate (RAL 9016).

Flexible coupler	78227
------------------	-------

NOTE! The images show components from below, while the dimension sketches show components from above, including the position of the neutral (blue line).

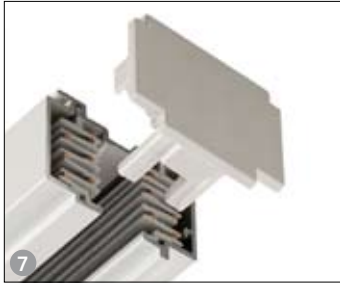

iTrack

Accessories

End section

7. End section used to terminate the track system. End section of white polycarbonate (RAL 9016).

End section	78228
-------------	-------

Cover

8. Cover unit with snap-on fixing to the track. Made of aluminium with a white enamelled finish (RAL 9016). Same height as Dual luminaire and emLED unit.

iTrack cover 1200 mm	27997
iTrack cover 1500 mm	27998

Installation accessories

9. Ceiling bracket of white enamelled aluminium with a white finish (RAL 9016). For installation on the ceiling.

Ceiling bracket	78248
-----------------	-------

10. Pendant bracket of white aluminium (RAL 9016) with wire-lock for suspended installation.

Pendant bracket	78249
Wire, 4 m with Gripple clip No. 1	96838

11. Discreet ceiling bracket with wire suspension and cable bushing.

Wire suspension 1,5 m	91696
-----------------------	-------

Sensor units

12. Sensor unit of white polycarbonate (RAL 9016) with multisensor 312. Supplied with two possible connection options. C1/C2 for 1–63 DALI addresses and X1/X2 for 64–126 DALI addresses

iTrack Sensor	34955
Remote control (DigiDim 303)	86121
Power supply unit (DigiDim 402)	86123

Emergency lighting units

13. Emergency lighting unit of aluminium with a white enamelled finish (RAL 9016) and white polycarbonate end caps.

iTrack emLED potential-free decentralised (for connection to UL). Self test as standard to EN 62034.	34950
iTrack emLED decentralised (DALI)	
(for connection to UL and C1/C2 or X1/X2)	34951
iTrack emLED centralised (for connection to E1/E2)	34952

HEAD OFFICE SWEDEN
Fagerhults Belysning AB
SE-566 80 Habo, Sweden
Tel +46 36 10 85 00
Fax +46 36 10 86 99
www.fagerhult.com

Fagerhult develops, manufactures and markets professional lighting systems for public environments such as offices, schools, industries and hospitals. Our operations are run with a constant focus on design, function, flexibility and energy saving solutions.

Fagerhult is a member of the Fagerhult Group, the largest lighting group in the Nordic region and a leading company in Europe. We have sales companies in more than 15 countries and production units in Europe, China and Australia. In 2009 the group had sales of SEK 2.4 billion and is listed on the OMX Nordic Exchange in Stockholm, Mid Cap list.

AUSTRALIA
Eagle Lighting
17-19 Jets Court
Melbourne Airport, VIC 3045
Tel 03 9344 7444
Fax 03 9344 7433
eagle@eaglelighting.com.au
www.eaglelighting.com.au

FAGERHULT

