

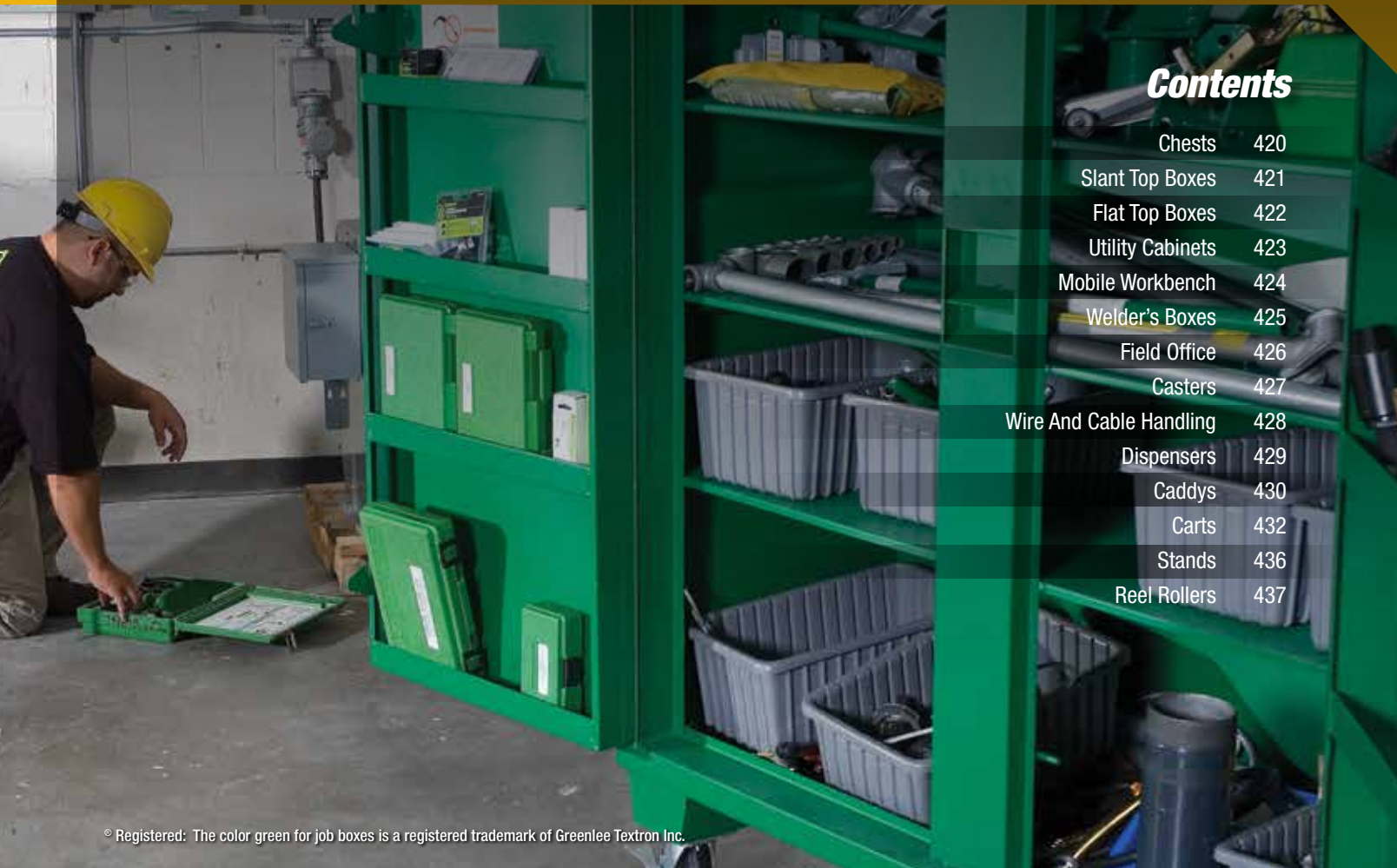

STORAGE & MATERIAL HANDLING

CONTRACTORS THE WORLD OVER RELY ON GREENLEE STORAGE AND MATERIAL HANDLING SOLUTIONS TO KEEP PRODUCT SAFE. FROM SMALL CHESTS TO LARGE FIELD OFFICES, AND NOW WITH NEWLY-DESIGNED ERGONOMIC FEATURES, GREENLEE STORAGE AND HANDLING SOLUTIONS ARE BUILT AS TOUGH AS THE TRADE.



Contents

Chests	420
Slant Top Boxes	421
Flat Top Boxes	422
Utility Cabinets	423
Mobile Workbench	424
Welder's Boxes	425
Field Office	426
Casters	427
Wire And Cable Handling	428
Dispensers	429
Caddys	430
Carts	432
Stands	436
Reel Rollers	437

© Registered: The color green for job boxes is a registered trademark of Greenlee Textron Inc.

USA PHONE 800.435.0786
FAX 800.451.2632

CANADA PHONE 866.384.8813
FAX 800.524.2853

INT'L PHONE +1.815.397.7070
FAX +1.815.397.9247



STORAGE

Chests



2460



Optional casters available for increased mobility.
See page 427 for options

DIMENSIONS

	A	B	C	D	E	F	G	H	I
1332	14"	32"	19"	—	29.5"	—	—	—	16.75"
1636	17"	36"	19"	—	33.5"	—	—	—	16.75"
2142	20"	42"	20"	—	39.5"	—	—	—	17.75"
2448	25"	48"	24"	4"	45.5"	4"	19"	15.5"	21.75"
2448X	25"	48"	24"	—	45.5"	—	—	15.5"	21.75"
2460	25"	60"	24"	4"	57.5"	4"	19"	15.5"	21.75"
2460X	25"	60"	24"	—	57.5"	—	—	15.5"	21.75"
3048	30"	48"	30"	4"	45.5"	4"	24"	21.5"	27.75"
3048X	30"	48"	30"	—	45.5"	—	—	21.5"	27.75"
2472	25"	72"	24"	4"	69.5"	4"	19"	15.5"	21.75"
2472X	25"	72"	24"	—	69.5"	—	—	15.5"	21.75"

- Recessed and concealed lock protectors for maximum security against drilling and cutting lock. (Model 1332 and 1636 one lock protector only.)
- Finger-groove lid handle for easy opening.
- Convenient storage tray on back wall for small items (Models 2448, 2460, 2472, 3048).
- "X" models do not include rear tray for larger opening.
- Heavy-duty piano hinges with non-removable pin.
- Patented, ergonomically designed fold-down recessed handles.
- Angled 3-1/2" high support skids feature threaded holes for easy caster installation.
- Recommend #1 and #5 Masterlock® padlocks or equivalent.

SPECIFICATIONS

	1332	1636	2142	2448	2460	3048	2472
Capacity FT ³	4.9	6.7	9.7	16.6	20.8	25	25
Weight	78 lbs. (35 kg)	101 lbs. (46 kg)	124 lbs. (56 kg)	159 lbs. (72 kg)	184 lbs. (83 kg)	200 lbs. (91 kg)	214 lbs. (97 kg)

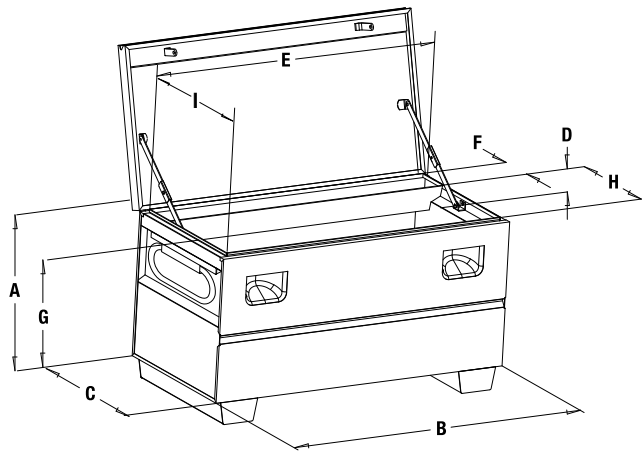

CAT. NO.	UPC NO.	DESCRIPTION
1332	38717	Storage chest without tray
1636	38718	Storage chest without tray
2142	31651	Storage chest without tray
2448	23273	Storage chest
2448X	00852	Storage Chest without tray
2460	23363	Storage chest
2460X	00858	Storage Chest without tray
3048	23362	Storage chest
3048X	00859	Storage Chest without tray
2472	07483	Storage chest
2472X	00853	Storage Chest without tray

Slant-Top Boxes



3648



Hinged Lower Shelf



Optional casters available for increased mobility.
See page 427 for options

- Large capacity storage with traditional slant-top design.
- Recessed and concealed lock protectors provide maximum security against drilling and cutting locks.
- Channel reinforcements on lid, lock side panels into lid for added security when closed.
- Hinged lower shelf enables storage of larger items.
- Angled 3-1/2" high support skids feature threaded holes for easy caster installation.
- Angled handle recess prevents pinch points.
- Features two reinforced steel shelves with large lip to prevent items from rolling off (Model 2260, one shelf only).
- Model 2260 comes with lid support to form waist-high, flat work area.
- Patented, ergonomically designed fold-down recessed handles.
- Recommend #1 and #5 Masterlock® padlocks or equivalent.

SPECIFICATIONS	2260	3648	3660
Capacity FT ³	32	34	44
Weight	273 lbs. (124 kg)	270 lbs. (123 kg)	314 lbs. (142 kg)

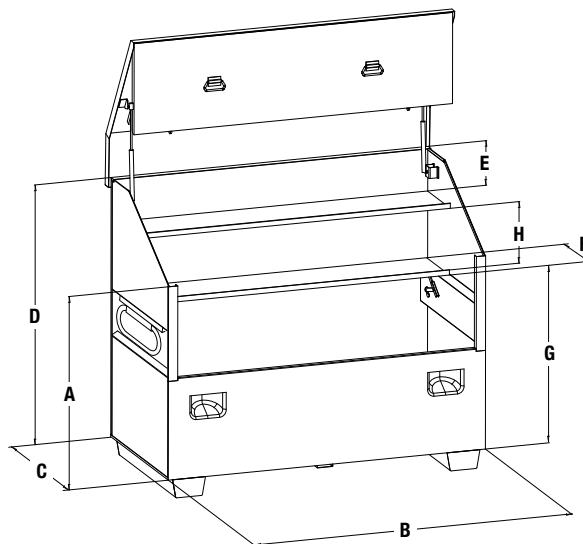

DIMENSIONS	A	B	C	D	E	F	G	H
2260	32"	22"	32"	36"	12"	12"	21"	—
3648	34"	36"	30"	48"	5"	12"	27"	11"
3660	44"	36"	30"	48"	5"	12"	27"	11"

CAT. NO.	UPC NO.	DESCRIPTION
2260	23270	Slant-top box
3648	23276	Slant-top box
3660	23196	Slant-top box

Flat-Top Boxes



4872



Hinged Lower Shelf



Optional casters available for increased mobility. See page 427 for options

- Flat-top design provides more storage capacity for tall, bulky items, plus a large work surface for jobsite plans.
- Recessed and concealed lock protectors for maximum security against drilling and cutting lock.
- Channel reinforcements on lid, lock side panels into lid for added security when closed.
- Hinged lower shelf allows for easy storage of larger objects (except Model 3360).
- Side-wall storage (except Model 3360).
- Double hinge cover folds up and out of the way.
- Angled 3-1/2" high support skids feature threaded holes for easy caster installation.
- Patented, ergonomically designed fold-down recessed handles.
- Recommend #1 and #5 Masterlock® padlocks or equivalent.

SPECIFICATIONS	3360	4848	4860	4872
Capacity FT ³	34.5	40	50	60
Weight	256 lbs. (116 kg)	283 lbs. (128 kg)	358 lbs. (162 kg)	373 lbs. (169 kg)

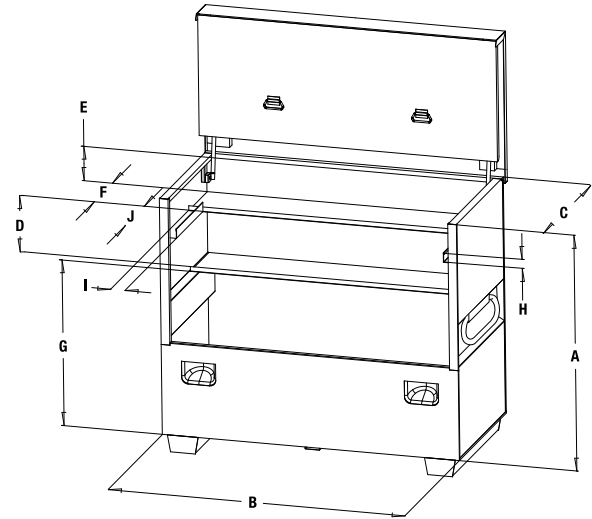

DIMENSIONS

	A	B	C	D	E	F	G	H	I	J
3360	33"	60"	30"	—	12.5"	12"	20"	—	—	—
4848	48"	48"	30"	11"	7"	12"	27"	2"	3"	17"
4860	48"	60"	30"	11"	7"	12"	27"	2"	3"	17"
4872	48"	72"	30"	11"	7"	12"	27"	2"	3"	17"

CAT. NO.	UPC NO.	DESCRIPTION
3360	38719	Flat-Top box
4848	35043	Flat-Top box
4860	35057	Flat-Top box
4872	07487	Flat-Top box

Utility Cabinets



5660LH

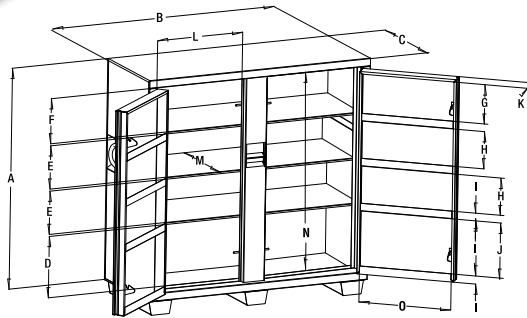

DIMENSIONS

	A	B	C	D	E	F	G	H	I	J	K	L	M	N	O
5660L	56"	60"	24"	15"	10.5"	11.5"	10"	10"	2"	14"	3"	23.5"	20.5"	50.5"	24"
5660LH	56"	60"	24"	15"	10.5"	11.5"	10"	10"	2"	14"	3"	23.5"	20.5"	50.5"	24"
5760TD	56"	60"	30"	15"	10.5"	11.5"	10"	10"	2"	14"	3"	23.5"	26.5"	50.5"	24"

- Recessed and concealed lock protectors for maximum security against drilling and cutting lock.
- Flush-mounted doors.
- Finger-groove door handles.
- Front-door storage.
- Large, lower storage areas for bigger items.
- Angled 3-1/2" high support skids feature threaded holes for easy caster installation.
- Three 3-1/2" high support skids.
- Weather-resistant design.
- Open storage for shovels, picks, brooms and other long-handled tools. (Model 5660LH only.)
- Patented, ergonomically designed fold-down recessed handles.
- Recommend #1 and #5 Masterlock® padlocks or equivalent.

SPECIFICATIONS	5660L	5660LH	5760TD
Capacity FT ³	46	46	59.3
Weight	389 lbs. (176 kg)	375 lbs. (170 kg)	441 lbs. (200 kg)

CAT. NO.	UPC NO.	DESCRIPTION
5660L	38659	Utility cabinet
5660LH	07486	Utility cabinet
5760TD	07969	Utility cabinet



Optional casters available for increased mobility. See page 427 for options

Mesh Cabinet

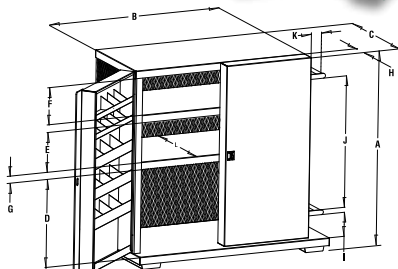

- High-visibility mesh screen on three (3) sides.
- Forty-eight (48) smaller, individual compartments, enabling storage of smaller tools and accessories.
- Platform for long-handle tools.
- Sturdy handle for mobility.
- Supplied with two (2) swivel casters and two (2) rigid 4" (102 mm) casters for easy mobility (Model 696).
- Recommend #1 and #5 Masterlock® padlocks or equivalent.

SPECIFICATIONS

Capacity FT ³	37.3
Weight	401 lbs. (182 kg)

CAT. NO.	UPC NO.	DESCRIPTION
5060MESH	04460	Mesh cabinet

DIMENSIONS

A	B	C	D	E	F	G	H	I	J	K	L
52"	48"	28"	22"	10.5"	10"	2"	4"	5"	35"	5.5"	23"

Bi-Fold Cabinet

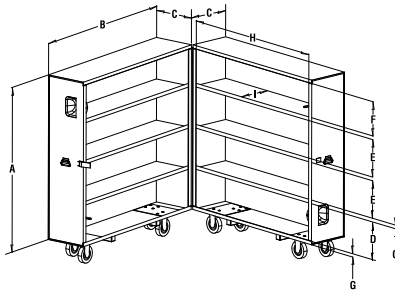

- Maximum storage capacity with minimum floor space requirements.
- Four (4) individual 15" d. x 14-1/2" h. x 60" w. (381 x 368 x 1524 mm) storage compartments on each side.
- Reinforced steel shelves welded in place for added strength and durability.
- All shelves feature large front lip to keep small items from rolling off.
- Each bi-fold section is mounted on four casters for easy opening and closing.
- Six (6) swivel and two (2) rigid 6" (152 mm) casters included for easy mobility (Models 503 and 603).
- Recommend #1 and #5 Masterlock® padlocks or equivalent.

SPECIFICATIONS

Capacity FT ³	60.4
Weight	549 lbs. (249 kg)

DIMENSIONS

A	B	C	D	E	F	G	H	I
58"	60"	15"	13"	13"	12"	1"	57"	14.5"

CAT. NO.	UPC NO.	DESCRIPTION
5860	35068	Bi-fold cabinet
04339	04339	Latch Repair Kit (5860)
54997	54997	Latch (5860)
54998	54998	Strike (5860)
55124	55124	Latch Threaded Rod (5860)

Mobile Workbench

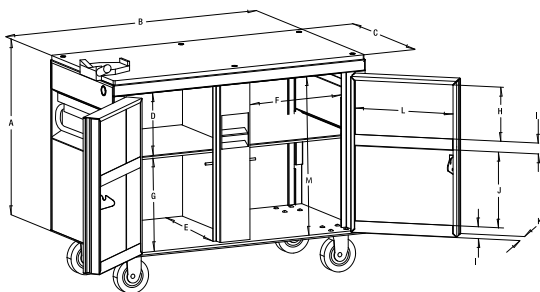

- Tough composition board work surface on top with built-in chain vise and telescoping wrench stop.
- Removable self-stored shelf enables storage of larger items.
- Supplied with two (2) locking swivel casters and two (2) rigid 6" (152 mm) casters for easy mobility (Model 703).
- Recessed and concealed lock protectors for maximum security against drilling and cutting lock.
- Finger-groove door handles.
- Large lower storage areas for bigger items.
- Continuous, non-removable hinge pins to prevent theft.
- Patented, ergonomically designed fold-down recessed handles.
- Recommend #1 and #5 Masterlock® padlocks or equivalent.
- Includes heavy-duty chain vise (3548 only)

SPECIFICATIONS

Capacity FT ³	20
Weight	293 lbs. (133 kg)

DIMENSIONS

A	B	C	D	E	F	G	H	I	J	K	L	M
30"	48"	24"	11"	20.5"	17.5"	15"	9.5"	2"	13"	3"	17"	27"

CAT. NO.	UPC NO.	DESCRIPTION
3548	31229	Mobile workbench

Welder's Boxes



1230

- Protects small tools and supplies. Single lock hasp for use with padlock.
- Compact side handles for easy portability.
- Heavy-duty hinges, plus chain connector to hold lid in open position.
- Recommend #1 and #5 Masterlock® padlocks or equivalent.

SPECIFICATIONS	1230	1531
Capacity FT ³	3.3	4.8
Height	12"	15"
Width	30"	31"
Depth	16"	18"
Weight	42 lbs. (19 kg)	52 lbs. (24 kg)

CAT. NO.	UPC NO.	DESCRIPTION
1230	31510	Welder's box
1531	23274	Welder's box
1223NS	54498	Heavy Duty Welder's box

Field Office



- Slanted work surface with lockable, concealed storage area.
- Concealed lock protectors protect locks from drilling and cutting.
- Weather stripping on doors to help protect documents and tools from the elements.
- Lid with heavy-duty gas spring and a locking arm for ease of opening and safety.
- Shelving throughout, for organizing and storing jobsite tools and supplies.
- Grooved front doors for ease of opening and storage compartment access.
- Patented, ergonomically designed fold-down recessed handles.
- Continuous, non-removable pin hinges.
- Overlapping corners, rolled edges, and strategically placed reinforcements for added strength.
- Recommend #1 and #5 Masterlock padlocks or equivalent.
- Welded 16-gauge steel construction for durability.
- Transportable with forklift.
- Optional casters available for increased mobility.

SPECIFICATIONS

Capacity FT ³	60.4
Weight	549 lbs. (249 kg)



Tamper-proof lock protectors (for upper and lower doors).

Slanted work surface with lockable, concealed storage area.

Door grooves provide a gripping surface for convenient opening.

Top door opens with a gas spring and is supported by a locking arm.

(Tools sold separately)



Optional casters available for increased mobility. See page 427 for options

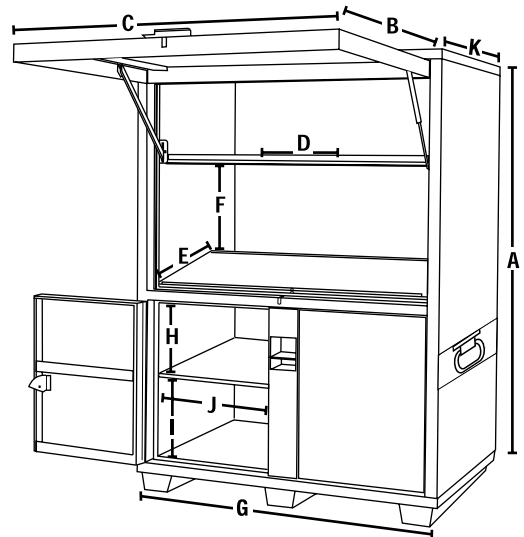

DIMENSIONS

A	B	C	D	E	F	G	H	I	J	K
80"	41.6"	55.6"	20.6"	26.8"	19.2"	60"	14"	15.5"	24"	42"

CAT. NO.	UPC NO.	DESCRIPTION
8060-DLX	04719	Field Office

Replacement Parts

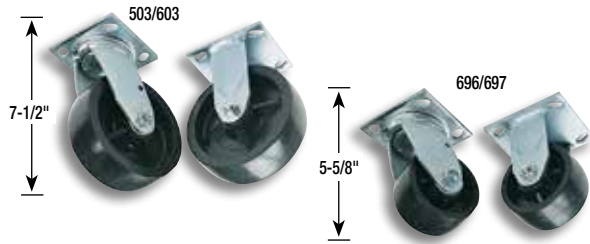

- Caster bolt pattern 2-7/8" x 3-1/4".
- Polyolefin-injected molded hard casters: stain-resistant, chemical-resistant, and non-marking.

CASTER SELECTION CHART

STORAGE BOX CAT. NO.	CASTER CAT NO.			
	503	603	703	696
1332	✓	✓	✓	✓
1636	✓	✓	✓	✓
2142	✓	✓	✓	✓
2448	✓	✓	✓	✓
2460	✓	✓	✓	✓
3048	✓	✓	✓	✓
2472	✓	✓	✓	✓
1230				
1531				
5060MESH	✓	✓	✓	Included
3360	✓	✓	✓	✓
4848	✓	✓	✓	✓
4860	✓	✓	✓	✓
4872	✓	✓	✓	✓
2260	✓	✓	✓	✓
3648	✓	✓	✓	✓
3660	✓	✓	✓	✓
5660L	✓	✓	✓	✓
5660LH	✓	✓	✓	✓
5760TD	✓	✓	✓	✓
5860	Included	Included	✓	✓
3548	✓	✓	Included	✓
8060DLX	✓	✓	✓	✓

SPECIFICATIONS	503	603	703	696	697
Diameter	6 in. (152 mm)	6 in. (152 mm)	6 in. (152 mm)	4 in. (102 mm)	4 in. (102 mm)
Tread	2 in. (51 mm)	2 in. (51 mm)	2 in. (51 mm)	2 in. (51 mm)	2 in. (51 mm)
Capacity	2000 lbs. (907 kg)	2000 lbs. (907 kg)	2000 lbs. (907 kg)	1600 lbs. (726 kg)	1600 lbs. (726 kg)
Ship Weight	22 lbs. (10 kg)	20 lbs. (9 kg)	20 lbs. (9 kg)	13 lbs. (6 kg)	15 lbs. (7 kg)

*Each caster set includes (16) 3/8-16 x 1" self-threading mounting screws.
 †Each caster set includes (16) 3/8-16 x 1" carriage bolts; (16) 3/8-16 hex nuts; (16) 3/8 lockwashers.
 Note: Screw/washer kit p/n 50062913 is necessary for mounting 703 casters on boxes other than 3548.

CAT. NO.	UPC NO.	DESCRIPTION
503*	28044	4 Swivel
603*	23405	2 Rigid, 2 Swivel
703†	08420	2 Rigid, 2 Locking Swivel
696*	15341	2 Rigid, 2 Swivel
697*	89189	4 Swivel
52025978	20965	Lid Support – (L) Side
52025979	20966	Lid Support – (R) Side
08428	08428	10 mm Gas Spring Ball Stud Replacement Kit (all Slant/Flat-Tops)
53950	53950	Gas Springs for 2260
53951	53951	Gas Springs for 3360 only
08427	08427	13 mm Gas Spring Ball Stud Replacement Kit (8060 DLX)
55294	55294	Replacement Gas Spring Kit – Shock and (2) Clips (8060 DLX)
01886	01886	Replacement Gas Spring Kit for 4872, 4848, 4860, 3648 & 3660

Greenlee Green Spray Touch-up Paint



- Closely matches Greenlee painted products.

SPECIFICATIONS

Weight 1.2 lbs. (.5 kg)

CAT. NO.	UPC NO.	DESCRIPTION
22618	22618	13 oz. (384 ml) Aerosol Can of Greenlee Green Spray Paint
10378	10378	13 oz. (384 ml) Aerosol Can of Greenlee Flat Green Spray Paint*

NOTE: The color green is a registered trademark for Test Instruments, Job Boxes, Benders and Pulling Equipment.
 *For Storage Boxes

WIRE AND CABLE HANDLING

Hand Caddy

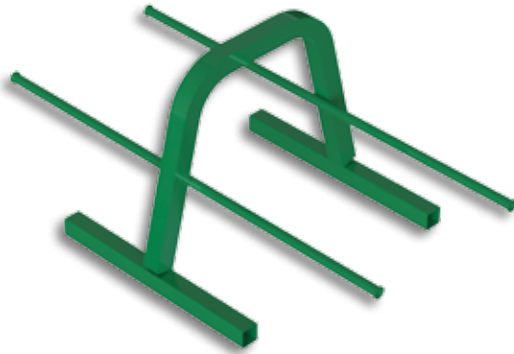

- Holds four 500' (152.4 m) spools of #10 AWG (7" dia. by 6"-10" wide)
- Holds up to eight 500' (152.4 m) spools of #12 AWG (7" dia. x 5" wide)
- 3/8" (9.5 mm) diameter solid steel spool support spindles.
- Spool retaining washers on spindles.
- Pinless design eliminates loose parts.

SPECIFICATIONS

Size	10-1/2" (267 mm) H x 14" (356 mm) W x 22.5" (572 mm) L
Capacity	Eight 500' (152.4 m) spools of #12 AWG; Four 500' (152.4 m) spools of #10 AWG Maximum Spool Diameter: 9" (229 mm) Maximum Spool Width: 10.5" (266 mm)
Weight	5 lbs. (2 kg)

CAT. NO.	UPC NO.	DESCRIPTION
9502	08187	Hand Caddy

Data Cable Caddy



- Width is ideal for large diameter spools of coax, data and communications cable.
- Especially handy for 6" (152 mm) wide and up to 19" (483 mm) diameter spools.
- Folds down for easy storage.
- Pinless design eliminates loose parts.

SPECIFICATIONS

Size	21" (533 mm) L x 28-1/2" (724 mm) W x 11-1/2" (292 mm) H
Capacity	Maximum Total Spool Weight: 100 lbs. (45 kg) Maximum Spool Diameter: 19" (483 mm) Maximum Spool Width: 24.50" (622 mm)
Weight	11 lbs. (5 kg)

CAT. NO.	UPC NO.	DESCRIPTION
9520	01228	Data Cable Caddy

BX-Armored Coiled Cable Dispenser



- Dispense armored cable, flexible conduit, Greenfield® or NM-B cable fast and easy without twists or tangles.
- Base rotates to dispense the cable without overpulling.
- Large pulling eye rotates freely and can be used as a carrying handle when the dispenser is empty.

SPECIFICATIONS

Size	13-1/2" (343 mm) H x 26" (660 mm) diameter
Capacity	One 250' (76 m) coil of 14/2, 14/3, 12/2, or 12/3 armored cable or romex.
Weight	32 lbs. (14 kg)

CAT. NO.	UPC NO.	DESCRIPTION
37218	37218	Armored Cable Dispenser

Caddy Basket Cable Dispenser



9525

STUD MOUNT CADDY

- Fits both 2x4 and 2x6 studs.
- Dispense coils of NM-B or armored cable.
- Swivel eyelet eliminates tangles.

SPECIFICATIONS

Size	29-1/2" (749 mm) H x 20-3/4" (527 mm) W
Max Capacity	100 lbs. (45.4 kg)
Weight	10.5 lbs. (4.8 kg)

CAT. NO.	UPC NO.	DESCRIPTION
9525	02070	Stud Mount Dispenser

Hanging Cable Dispenser



- Hangs virtually anywhere
- Rugged aluminum, steel, and nylon construction
- Collapses for easy storage
- Storage bag included

SPECIFICATIONS

Length Set Up	37-1/2" (953 mm)
Width Set Up	23-1/2" (597 mm)
Capacity	250' of NM or MC cable up to 75 lb
Weight	3-1/2 lbs. (1.6 kg)

CAT. NO.	UPC NO.	DESCRIPTION
9522	12671	Hanging Cable Dispenser

Deluxe Wire Caddy



- All welded steel frame.
- 6 wire spool axles with spring clip locks.
- Collapsible wire guide.
- Swivel caster set with two (2) locking casters for easy use.

SPECIFICATIONS

Size	16" (406 mm) L x 26" (660 mm) W x 17-1/2" (444 mm) H
Capacity	Six 500' (152 m) spools up to 8" (203 mm) in diameter of #6 thru #10 AWG Maximum Spool Width: 2 x 8.5" (215 mm), 4 x 12.13" (308 mm)
Weight	14.8 lbs. (6.7 kg)

CAT. NO.	UPC NO.	DESCRIPTION
906	33026	Wire Caddy with Casters and Wire Guide
33405	33405	Caster Set (2 swivel, 2 swivel lock)
50303	50303	Hitch Clip

6-Spindle Wire Caddy



- All steel welded frame with 6 reel spindles and feeding eye.
- Angled spindles keep reels in place without locks and help brake the reel while paying out.
- Mobile, two (2) fixed wheels and one (1) that swivels and locks, allow easy movement and control.
- Fits through a 30" (762 mm) doorway.

SPECIFICATIONS

Size	39" (990 mm) L x 30" (762 mm) W x 31" (787 mm) H.
Capacity	Six 2,500' (762 m) spools up to 18" (457 mm) in diameter. Maximum Spool Width: 13" (330 mm)
Weight	88 lbs. (40 kg)

CAT. NO.	UPC NO.	DESCRIPTION
909	22875	Wire Dispenser
52284	52284	Swivel Caster (1)
52285	52285	Wheel (2)

6-Reel Caddy



- Holds up to six (6) 2,500' (762 m) spools of #14, #12, or #10 AWG wire.
- Folds for easy storage.
- Two (2) fixed wheels and two (2) locking swivel casters for easy portability.
- Pinless design eliminates loose parts.

SPECIFICATIONS

Size	41" (1041 mm) H x 32" (813 mm) W
Capacity	Six (6) 2500' (762 m) spools of #10 AWG wire Maximum Total Spool Weight: 450 lbs. (204 kg) Maximum Spool Diameter: 15" (380 mm) Maximum Spool Width: 14.75" (375 mm)
Weight	75 lbs. (34 kg)

CAT. NO.	UPC NO.	DESCRIPTION
9517	01225	6-Reel Caddy
R 01221	01221	Replacement Caster
R 01220	01220	Replacement Wheel

10-Reel Caddy



- Spindle sleeves to facilitate easier pay-out of wire.
- Holds up to ten (10) 2,500' (762 m) spools of #10 AWG wire.
- Folds down for easy storage.
- Two (2) fixed wheels and two (2) locking swivel casters for easy portability.
- Pinless design eliminates loose parts.

SPECIFICATIONS

Size	48" (1219 mm) H x 32" (813 mm) W
Capacity	Maximum Total Spool Quantity - Ten (10) 2500' (762 m) spools of #10 AWG wire Maximum Total Spool Weight: 750 lbs. (340 kg) Maximum Spool Diameter: 15" (380 mm) Maximum Spool Width: 14.63" (370 mm)
Weight	101 lbs. (46 kg)

CAT. NO.	UPC NO.	DESCRIPTION
9516	01222	10-Reel Caddy
R 01221	01221	Replacement Caster
R 01220	01220	Replacement Wheel

Wire Dispenser



- All welded steel construction.
- Includes two (2) fixed and two (2) swivel locking heavy-duty casters.
- The spool rack consists of ten (10) spindles and an adjustable guide loop, and can be turned 360° independent of the base.
- Spindles are angled to contain reels and act as a brake while paying out wire.
- Fits through a 32" (812 mm) opening.

SPECIFICATIONS

Size	36-1/4" (921 mm) L x 31-1/2" (800 mm) W x 59" (1499 mm) H.
Capacity	Ten (10) 2500' (762 m) spools up to 18" (457 mm) in diameter. Maximum Spool Width: 14.18" (360 mm)
Weight	196 lbs. (89 kg)

CAT. NO.	UPC NO.	DESCRIPTION
910	21982	Wire Dispenser
R 51488	51488	Caster (Rigid)
R 53259	53259	Caster (Swivel)

Hand Truck / Wire Cart



- Holds up to twelve (12) spools of #12 AWG wire or eight (8) spools of #10 AWG wire.
- Pinless design eliminates loose parts.
- Four (4) solid steel 1/2" (13 mm) spindles included.
- Lay cart flat when dispensing wire. Upright for use as hand truck.

SPECIFICATIONS

Size	48" (1219 mm) H x 28-1/4" (718 mm) W
Capacity	Maximum Total Spool Weight: 200 lbs. (90.7 kg) 4000' (1219 m) # 10 AWG wire Maximum Spool Diameter: 7.5" (190 mm) Dolly Lift (Maximum): 250 lbs. (113 kg) Maximum Spool Width: 18" (457 mm)
Weight	32 lbs. (14 kg)

CAT. NO.	UPC NO.	DESCRIPTION
9505	01205	Hand Truck Caddy
01207	01207	Spindle (9505/9510)

Deluxe A-Frame Wire Cart



- Holds up to twenty four (24) spools of #12 AWG wire or sixteen (16) spools of #10 AWG wire.
- Folds for easy storage.
- Pinless design eliminates loose parts.
- Eight (8) solid steel 1/2" (12.7 mm) spindles included.

SPECIFICATIONS

Size	48" (1219 mm) H x 28-1/4" (718 mm) W
Capacity	Maximum Total Spool Weight: 400 lbs. (181 kg) Maximum Spool Diameter: 7.5" (190 mm) Maximum Spool Width: 18" (457 mm)
Weight	47 lbs. (21 kg)

CAT. NO.	UPC NO.	DESCRIPTION
9510	01214	Deluxe A-Frame Mobile Caddy
01207	01207	Spindle (9505/9510)

Hand Truck / Wire Cart



- Heavy-duty wheels for durability and easy transporting.
- Only 24" (609 mm) wide to fit through narrow doorways.
- Comes with five 5/8" (16 mm) diameter reel spindles for storing and dispensing up to fifteen spools of #14 wire.
- Storage space for three (3) spindles and clips eliminates loose parts when they are not in use.
- Expander kit available to increase capacity by 60%.

SPECIFICATIONS

Size	38733	46" (1168 mm) H x 24" (609 mm) W x 22-1/2" (571 mm) D
	10462	41" (1041 mm) H x 12-5/8" (321 mm) W
Weight	38733	58 lbs. (26 kg)
	10462	15.7 lbs. (7 kg)

WIRE CAPACITY CHART

NUMBER OF SPOOLS		MAXIMUM SPOOL DIAMETER	MAXIMUM SPOOL WIDTH	TYPICAL WIRE LENGTH
38733 WIRE CART	WITH 10462 EXPANDER			
15	24	7" (178 mm)	5-3/8" (137 mm)	500 ft. (152 m)
10	16	7" (178 mm)	8" (203 mm)	500 ft. (152 m)
3	5	12" (305 mm)	16-3/8" (416 mm)	2,500 ft. (762 m)
3	3	14" (356 mm)	16-3/8" (416 mm)	2,500 ft. (762 m)
2	2	22" (559 mm)	16-3/8" (416 mm)	1,000 ft. (305 m)

CAT. NO.	UPC NO.	DESCRIPTION
38733	38733	Hand Truck Wire Cart
A 10462	10462	Expander Kit
R 50303	50303	Hitch Clip
R 38774	38774	Spindle (38733)

Wire Cart



- Large capacity, excellent for storing, transporting or feeding wire.
- Save space, use and store vertically or horizontally.
- Five (5) strong reel axles with spring clip retainers plus two (2) positions for axle storage allows you to configure for large reels with no loose parts.
- Strong, yet lightweight, tubular steel welded construction with rugged 8" (203 mm) wheels.
- Will pass through a 28" (711 mm) opening.

SPECIFICATIONS

Size	54-1/2" (1384 mm) L x 27" (685 mm) W x 26-1/2" (673 mm) H when horizontal
Capacity	Six (6) 2,500' (762 m) spools up to 16" (406 mm) in diameter Fifteen (15) 500' (152 m) spools up to 8" (203 mm) in diameter Max. Spool Weight: 550 lbs. Maximum Spool Width: 24" (610 mm)
Weight	62 lbs. (28 kg)

CAT. NO.	UPC NO.	DESCRIPTION
911	31518	Wire Cart
R 31523	31523	Reel Shaft for 911 Wire Cart
R 50303	50303	Hitch Clip

Cable Reel Transporter



- All steel welded frame with heavy-duty wheels.
- Unique design provides easy setup for cable payout.
- Handle folds to save space when using as a dispenser.

SPECIFICATIONS

Size	63" (1600 mm) L x 29-7/8" (759 mm) W x 26-3/4" (679 mm) H when horizontal
Capacity	Reels of cable or BX up to 20" (508 mm) W and 40" (1016 mm) in diameter maximum total reel weight 300 lbs. (136 kg)
Weight	110 lbs. (50 kg)

CAT. NO.	UPC NO.	DESCRIPTION
916	32935	Cable Reel Transporter
33035	33035	Spindle for 916 Transporter
52466	52466	Wheel Kit (2)

Conduit and Pipe Storage Rack



- Easily stacks for storage and transportation of multiple units
- High strength steel frame holds up to 1000 lbs of material
- Heavy-Duty 6" casters (2 rigid, 2 swivel)
- Foldable material trees
- Stacking block securely fits in tree stock to prevent tumbling

SPECIFICATIONS

Capacity	1000 lbs. (454 kg)
Dimensions	58-1/2" (1486 mm) long x 34" (864 mm) wide x 63-1/2" (1613 mm) high
Folded Down	58-1/2" (1486 mm) long x 34" (864 mm) wide x 19" (483 mm) high
Weight	113 lbs. (51 kg)

CAT. NO.	UPC NO.	DESCRIPTION
668	15343	Mobile Conduit and Pipe Rack with 603 casters
503	28044	6" (152 mm) Diameter Caster Set, 4 Swivel
603	23405	6" (152 mm) Diameter Caster Set, 2 Swivel and 2 Rigid

Pipe Cart



- Easy, one-person operation saves time and money.
- Move standard 20 ft. (6.1 m) lengths of pipe.
- Large 3" x 12" (76 mm x 305 mm) wheels.
- Heavy-duty steel construction for long service life.

SPECIFICATIONS

Capacity	20" (508 mm) Diameter – 1000 lbs. (454 kg)
-----------------	--

CAT. NO.	UPC NO.	DESCRIPTION
36745	36745	Pipe Cart
02182	02182	Wheel Replacement Kit (1)

Rope Stands

- Use to organize and rewind rope.
- Welded steel with washer and spring clip to hold rope reel on stand.



654



405

See page 207 for rope

ROPE DIAMETER	UPS NO.	3/16" 4.8 MM	1/4" 6.4 MM	3/8" 9.5 MM	1/2" 12.7 MM	9/16" 14.3 MM	5/8" 15.9 MM	3/4" 19.1 MM	7/8" 22.2 MM
405 Rope Stand 250' (76 m) Rope 600' (182 m) Rope	21546	✓	✓						
		✓							
406 Rope Stand 300' (91 m) Rope 600' (182 m) Rope 1,000' (305 m) Rope 3,000' (914 m) Conduit Measuring Tape Measuring Tape Cat./UPC No.	21550		✓	✓	✓				
		✓	✓	✓	✓				
644 Rope Stand 300' (91 m) 600' (182 m) 1,200' (365 m)	15316			✓	✓	✓	✓		
					✓			✓	
654 Rope Stand 300' (91 m) 600' (182 m)	34362							✓	✓
								✓	✓

SPECIFICATIONS

rope stand model	weight	spindle diameter	maximum reel diameter	maximum reel width
405	5.2 lbs (2.4 kg)	1.50" (38 mm)	10"	6"
406	7.8 lbs (3.5 kg)	0.62" (16 mm)	13"	9"
644	11 lbs (5 kg)	1.50" (38 mm)	17"	16"
654	32.1 lbs (14.6 kg)	1.90" (48 mm)	24"	19"

Screw-Type Reel Stands



- Wide, welded steel base for added stability with four 5/8" mounting holes.
- Rollers fit in the spindle groove to keep the spindle in place and turning freely.
- Two stands and a spindle are required for a complete setup.

SPECIFICATIONS

Size	683 - 24" x 21" (610 x 533 mm) base; 54" (1372 mm) maximum height 687 - 15" x 15" (381 x 381 mm) base; 28" (711 mm) maximum height
Capacity	683 - 2,500 lbs. (1134 kg) each, 46" - 96" (1168 x 2438 mm) reel diameter 687 - 2,500 lbs. (1134 kg) each, 28" - 56" (711 x 1422 mm) reel diameter
Weight	683 - 42 lbs. (19 kg) 687 - 22 lbs. (10 kg)

CAT. NO.	UPC NO.	DESCRIPTION
683	15372	Reel Stand 22" - 54" (559 - 1372 mm)
687	17076	Reel Stand 13" - 27" (330 - 711 mm)
A 684	15375	Spindle for 683 Reel Stand
A 647	15321	Spindle for 687 Reel Stand
R 25591	25591	Stop Pin (683 - 2; 687 - 1)

Ratchet-Type Reel Stand



- Ratchet mechanism to easily raise or lower the height.
- Rollers fit in the spindle groove to keep the spindle in place and turning freely.
- Two stands and a spindle are required for a complete setup.

SPECIFICATIONS

Size	24-1/2" x 23" (622 mm x 584 mm) base; 46-5/8" (1184 mm) maximum height
Capacity	5,000 lbs. (2268 kg) each 58" - 90" (1473 mm - 2286 mm) reel diameter
Weight	87 lbs. (39 kg)

CAT. NO.	UPC NO.	DESCRIPTION
656	21979	Ratchet Reel Stand 28" - 46-5/8" (711 mm - 1184 mm)
A 657	21980	Spindle for 656 Reel Stand
R 30291	30291	Handle with Grip

Reel Stand Spindles



- Steel spindles with grooves to fit reel stand rollers.

SPECIFICATIONS

Size	647 - 2-3/8" diameter x 62" (60 x 1575 mm) 657 - 3-1/2" diameter x 100" (89 x 2540 mm) 684 - 2-3/8" diameter x 76" (60 x 1930 mm)
Capacity	647 - 5,000 lbs. (2268 kg) 59" (1500 mm) between grooves 657 - 7,500 lbs. (2388 kg) 94" (2540 mm) between grooves 684 - 5,000 lbs. (2268 kg) 73" (1854 mm) between grooves
Weight	647 - 42 lbs. (19 kg) 657 - 124 lbs. (56 kg) 684 - 50 lbs. (23 kg)

CAT. NO.	UPC NO.	DESCRIPTION
647	15321	Spindle for 687 Reel Stand
657	21980	Spindle for 656 Reel Stand (only)
684	15375	Spindle for 683 Reel Stand

Reel Rollers

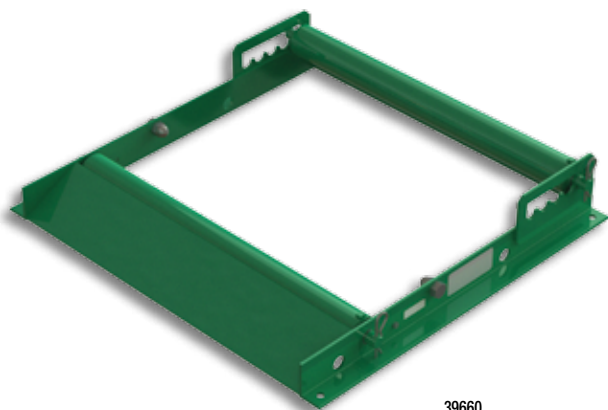

39660



39661

- Heavy-duty welded steel construction.
- Built-in loading ramps.
- Adjustable to various reel widths and diameters. (21" dia. min.)
- Roller locks for unloading.
- Side ball rollers for centering.
- Fast, convenient ground-level setup for paying out large cable reels.

SPECIFICATIONS

Size	Weight
39660 - 32" (813 mm) L x 34" (864 mm) W	87 lbs. (39 kg)
39661 - 32" (813 mm) L x 11" (279 mm) W	45 lbs. (20 kg)
39664 - 48" (1067 mm) L	9 lbs. (4 kg)
39666 - 32" (813 mm) L x 48" (1219 mm) W	99 lbs. (45 kg)

Capacity	Reel Width
39660	2,500 lbs. (1134 kg) 30" (762 mm) max reel width
39661	2,000 lbs. (902 kg) per pair, 42" (1067 mm) max reel width
39666	2,000 lbs. (902 kg) 42" (1067 mm) max reel width

CAT. NO.	UPC NO.	DESCRIPTION
39660	39660	Reel Roller, single platform roller
39661	39661	Reel Roller, single (two required)
39664	39664	Spreader Kit, two 48" spreader bars
39666	39666	Reel Roller Kit, (includes two 39661 rollers and one 39664 spreader kit)

Greenlee Green Spray Touch-up Paint



- Closely matches Greenlee painted products.

CAT. NO.	UPC NO.	DESCRIPTION	WEIGHT	
			LBS.	KG
22618	22618	13 oz. (384 ml) Aerosol Can of Greenlee Green Spray Paint	1.2	.5
10378	10378	13 oz. (384 ml) Aerosol Can of Greenlee Flat Green Spray Paint*	1.2	.5

*NOTE: The color green is a registered trademark for Test Instruments, Job Boxes, Benders and Pulling Equipment.
Storage Box

NOTES