

LEINE  LINDE

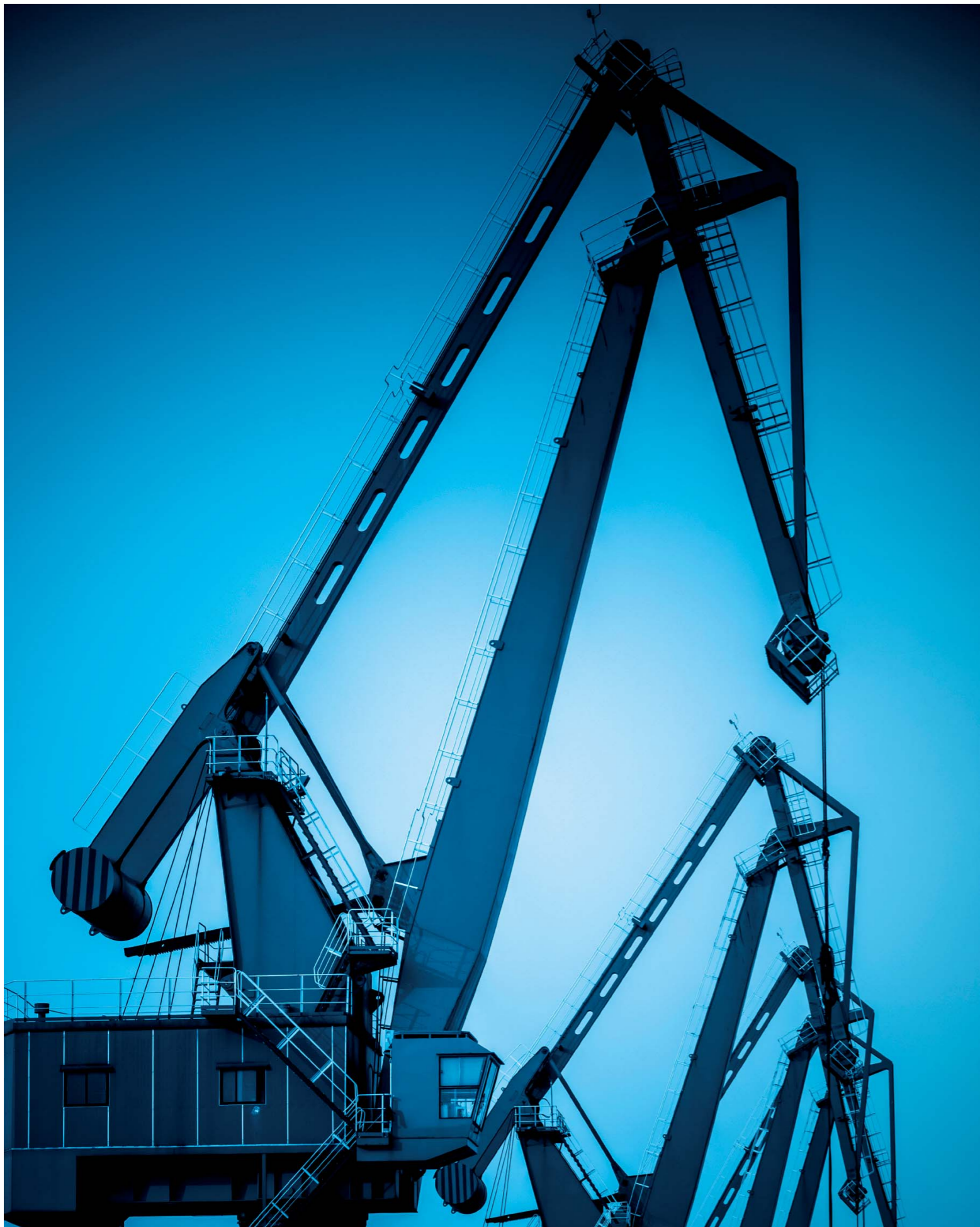

COMPACT 700 SERIES

ENCODERS FOR DRIVES



Robustness in tight spaces

An encoder is mounted at the rear of a motor and therefore affects the motor's overall length. In tight spaces, the build length can be restricted. Leine & Linde's 700 series is designed to be as short as possible without compromising with the robustness.

Compact design

The 700 series is compact and robust. The series features large hollow shafts up to 25.4 mm, which means that it can often be mounted directly on the motor's shaft without an intermediate adapter for shaft reduction. This characteristic contributes to minimising the overall build length, and at the same time facilitates mounting. Despite its compactness, the encoder is designed for the tough environments where a typical Leine & Linde product is used. Mechanically it features a dual set of heavy

duty bearings and a well-encapsulated enclosure. Electronically it is built for reliability in tough environments where it is subjected to vibrations and electrical disturbances.

Modularity

Leine & Linde has a wide range of electrical interfaces to choose among – there is always a solution optimised for the particular application where the encoder is needed. The signals can consist of square waves, sine waves or even be optical with the help of a gateway for OptoLink transmission.

On the mechanical side, there is multitude of different shaft variants that cover the market's standards for both inch- and millimetre-based dimensions.

Modularity

Electronics

Output interfaces (supply voltage):

- HTL (5-30 Vdc)
- HCHTL (9-30 Vdc)
- TTL (5 Vdc)
- RS422 (9-30 Vdc)
- 1 Vpp (5 Vdc)

Resolution

Incremental pulses per revolution:

- | | |
|-----------|-------------|
| ▪ 10 ppr | ▪ 1000 ppr |
| ▪ 50 ppr | ▪ 1024 ppr |
| ▪ 100 ppr | ▪ 1200 ppr |
| ▪ 150 ppr | ▪ 1250 ppr |
| ▪ 200 ppr | ▪ 1800 ppr |
| ▪ 256 ppr | ▪ 2000 ppr |
| ▪ 300 ppr | ▪ 2048 ppr |
| ▪ 360 ppr | ▪ 2400 ppr |
| ▪ 400 ppr | ▪ 2500 ppr |
| ▪ 500 ppr | ▪ 3072 ppr |
| ▪ 512 ppr | ▪ 4000 ppr |
| ▪ 600 ppr | ▪ 4096 ppr |
| ▪ 720 ppr | ▪ 4800 ppr |
| ▪ 800 ppr | ▪ 5000 ppr |
| ▪ 900 ppr | ▪ 6350 ppr |
| | ▪ 10000 ppr |



Flange

- Torque bracket (120°)
- Tether arm (with insulation)

Shaft

Through-going hollow shafts with insulation:

- | | |
|----------|-------------|
| ▪ Ø25 mm | ▪ Ø1 inch |
| ▪ Ø20 mm | ▪ Ø5/8 inch |
| ▪ Ø16 mm | ▪ Ø3/4 inch |
| ▪ Ø14 mm | |
| ▪ Ø12 mm | |

Connection

- M23 connector 12 pin (CCW)
- MS connector 10 pin
- MS connector 7 pin
- Cable (free length)

Mechanics

This page offers an overview of the different mechanical variants available in the 700 series. Other variants can be created according to the code key on page 9.

Model CHI 703 with torque bracket and 10 pin MS connector

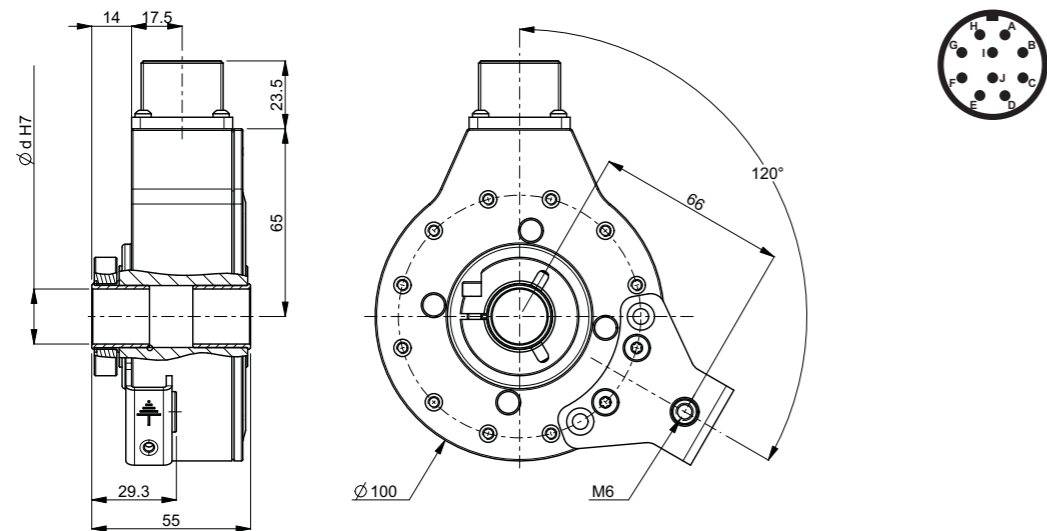

Model CHI 703 with tether arm and 7 pin MS connector

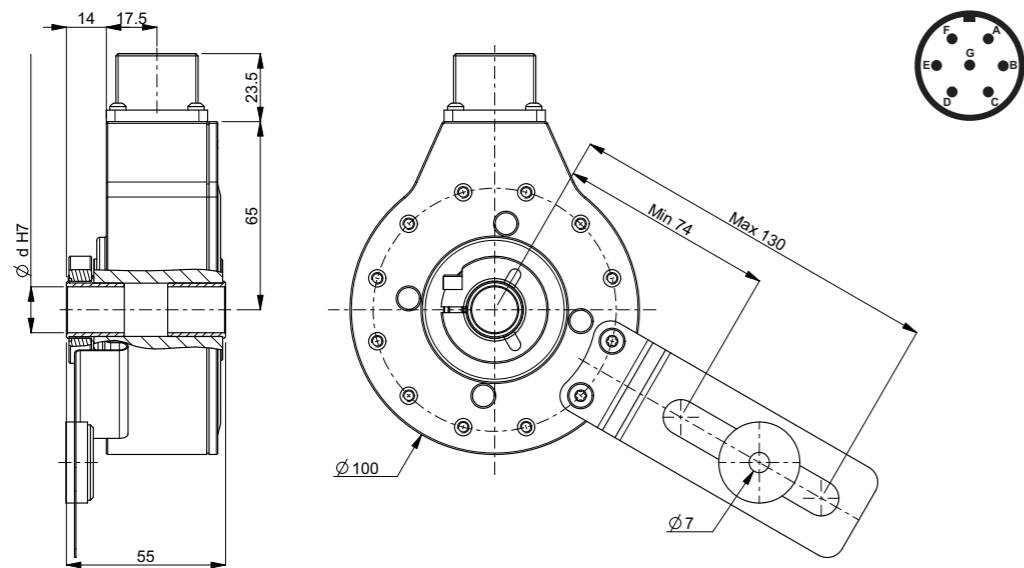

Model CHI 703 with torque bracket and 12 pin M23 connector

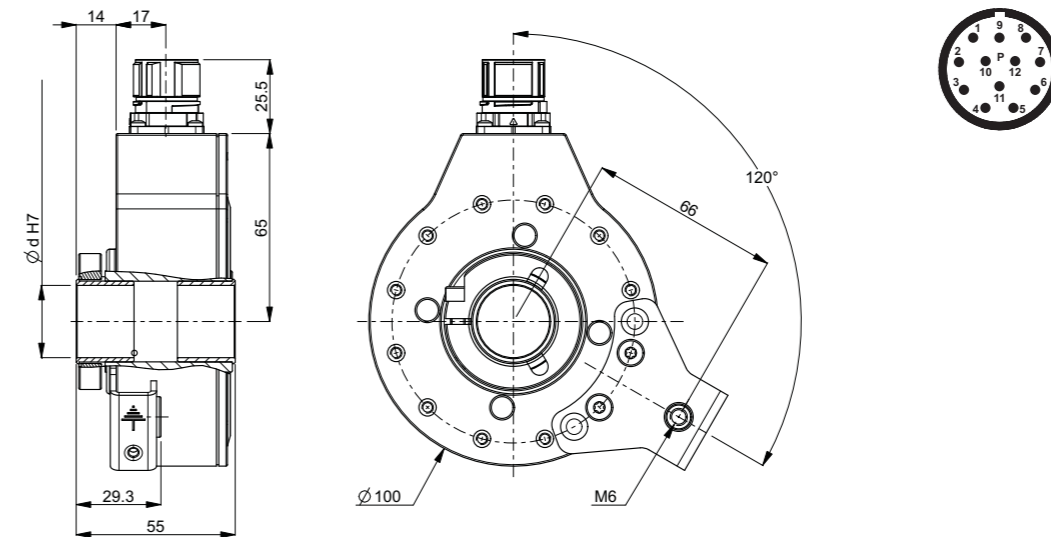

Model CHI 703 with tether arm and 12 pin M23 connector

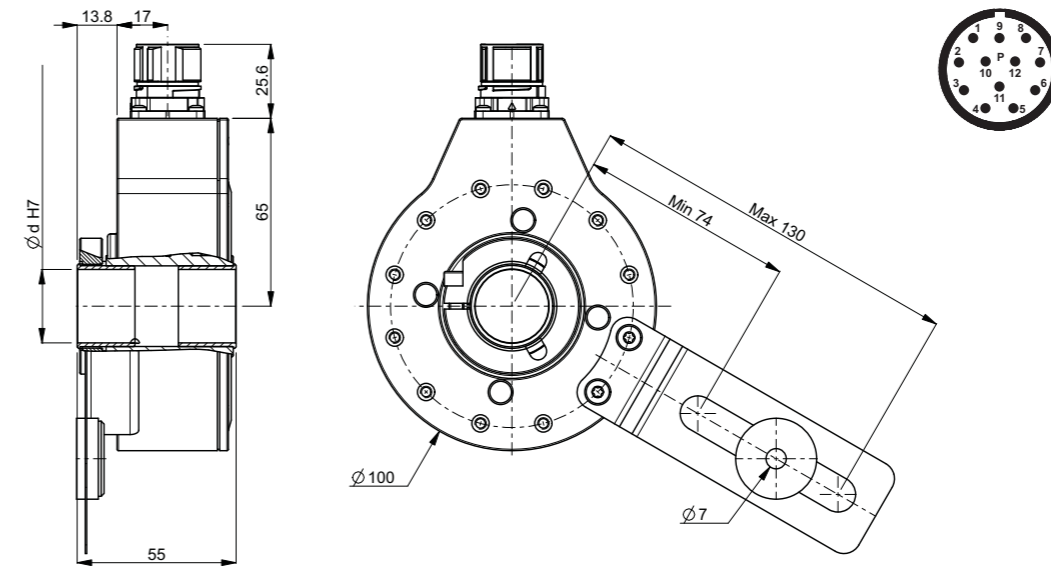

Model CHI 703 with torque bracket and cable

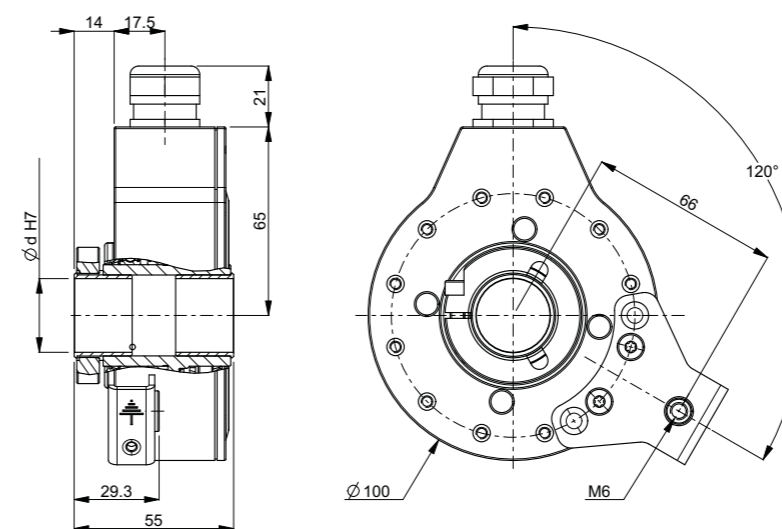

Electronics

Code key

Square wave signals

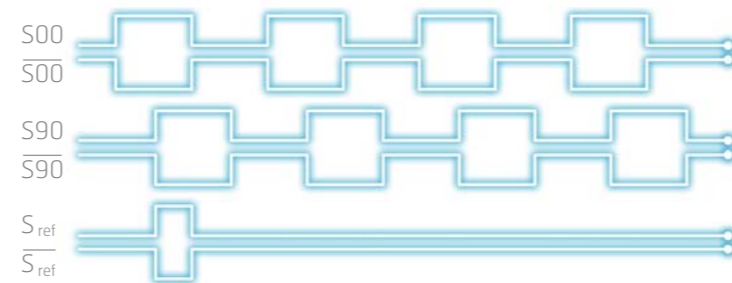

Interface	TTL	RS422	HTL	HCHTL
Supply	5 Vdc	9-30 Vdc	5-30 Vdc	9-30 Vdc
Output signal	5 Vdc	5 Vdc	5-30 Vdc	9-30 Vdc
Suitable for	Low frequencies over short cables	High frequencies over long cables	High frequencies over medium-length cables	Medium frequencies over long cables
Max frequency	200 kHz	200 kHz	200 kHz	200 kHz
Max cable length	50 m at 50 kHz	1000 m at 200 kHz	100 m at 100 kHz	350 m at 100 kHz

Sine wave signals

Sine waves are an alternative form of output signal. The analogue signal produces a unique amplitude for each position on the wave, allowing interpolation and very high resolutions. The interface 1 Vpp is often used in safety-critical applications where detection are required of extremely small movements.



CHI 703



Model

703 = Standard

Shaft

- 12 = Ø12 mm through-going hollow shaft
- 14 = Ø14 mm through-going hollow shaft
- 16 = Ø16 mm through-going hollow shaft
- 20 = Ø20 mm through-going hollow shaft
- 25 = Ø25 mm through-going hollow shaft
- 01 = Ø1 inch through-going hollow shaft
- 58 = Ø5/8 inch through-going hollow shaft
- 34 = Ø3/4 inch through-going hollow shaft

Flange

- 2 = Torque bracket 120°
- 9 = Tether arm with insulation

Electronics

- 1 = TTL (supply 5 Vdc, output 5 Vdc)
- 5 = HCHTL (supply 9-30 Vdc, output 9-30 Vdc)
- 6 = HTL (supply 5-30 Vdc, output 5-30 Vdc)
- 7 = RS422 (supply 9-30 Vdc, output 5 Vdc)
- 9 = Sinusoidal 1 Vpp (supply 5 Vdc, output 1 Vpp)

Connection

- 2 = M23 connector 12 pin (CCW)
- 7 = MS connector 7 pin
- 8 = MS connector 10 pin
- 9 = Cable (specify length upon order)

Resolution

- 10, 50, 100, 150, 200, 256, 300, 360, 400, 500, 512, 600, 720, 800, 900, 1000, 1024, 1200, 1250, 1800, 2000, 2048, 2400, 2500, 3072, 4000, 4096, 4800, 5000, 6350, 10000 ppr
- Sinusoidal 1 Vpp: 1024, 2048 ppr
- Other resolutions available upon request.

Performance

Technical data (based on HCHTL interface)

Operating temperature	-40..+85 °C *
Ingress protection class [IEC 60529]	IP67 (IP66 at shaft inlet)
Vibration [IEC 60068-2-6]	≤ 200 m/s ²
Shock [IEC 60068227]	≤ 1500 m/s ²
Cover material	Aluminum (anodized)
Weight	Approx. 1000 g
Shaft load (axial / radial)	50 N / 100 N
Rotational speed max	6000 rpm
Shaft material	Stainless steel with insulated peek insert
Short circuit protected	Yes
Polarity protected	Yes
Current consumption	60 mA at 24 Vdc (Max. 80 mA)
Output load	± 40 mA
Output frequency max	200 kHz
Cable length max	350 m at 100 kHz
Channel separation	90° el ± 25° el
Dividing error	± 25° el

* Available variants up to +100 °C

Accessories

Mounting accessories	Part number
Torque arm M6	01208014 (specify length upon order)
Mating connector 7 pin MS	00201020
Mating connector 10 pin MS	00201012
Mating connector M23 (CW pin layout for CCW encoder connector)	01209090
Gateways	Part number
CRG Overspeed	893254-xx
Speed monitor DZ260	00208070
CRG OptoLink Transmitter 9-30 Vdc supply, HTL input	01300320
CRG OptoLink Receiver 9-30 Vdc supply, HTL output	01300330
CRG OptoLink Receiver 9-30 Vdc supply, RS422 output	01300332
CRG OptoLink Receiver 5 Vdc supply, TTL output	731720-01

Contact us

SWEDEN / HEAD OFFICE

Address	Leine & Linde AB Box 8 SE-645 21 Strängnäs	Telephone	+46-(0)152-265 00
Visiting address	Olivehällsvägen 8	Fax	+46-(0)152-265 05
Delivery address	Västerportsvägen 20 SE-645 42 Strängnäs	E-mail	info@leinelinde.com
		Website	www.leinelinde.com

BRAZIL

T +55-11-2137-4416
F +55-11-2137-4425
info@leinelinde.com.br

DENMARK

T +45-862-308 34
F +45-862-306 21
info@leinelinde.dk

GERMANY

T +49-(0)7361-78093-0
F +49-(0)7361-78093-11
info@leinelinde.de

ITALY

T +39-(0)39-596 01 08
F +39-(0)39-971 69 00
info@leinelinde.it

CHINA

T +86-(021)-52 58 35 66
F +86-(021)-52 58 35 99
info@leinelinde.cn

FINLAND

T +358-(0)9-561 72 00
F +358-(0)9-561 72 020
info@leinelinde.fi

INDIA

T +91-11-2617 2504
F +91-11-4058 2516
info@leinelinde.in

SOUTH KOREA

T +82-55-266 2372
F +82-55-266 2373
info@leinelinde.co.kr

Leine & Linde's worldwide presence. Read more at www.leinelinde.com.

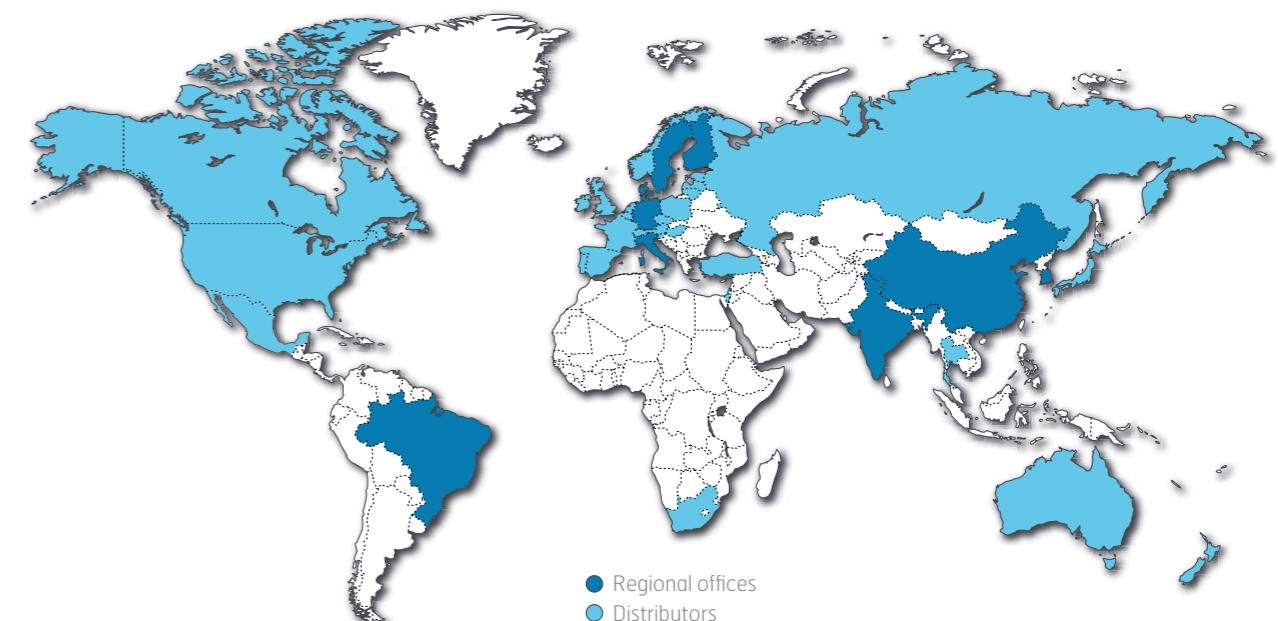

The best encoders are those you never have to think about. Those that simply do their job – year after year. Leine & Linde develops and manufactures customised encoder solutions for demanding environments, advanced measuring systems for accurate feedback of speed and position.

LEINE  LINDE

+46-(0)152-265 00 www.leinelinde.com