

niko
Illuminating ideas.

General catalogue

2011 - 2012

Export

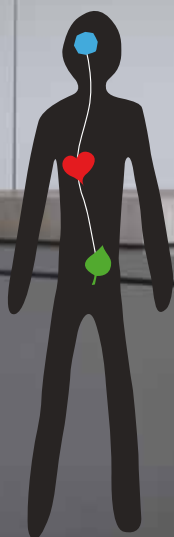

Niko Home Control



Trunking systems

For a neat, professional finish

Integrating the cabling in an interior design without drilling or channeling work?

The Niko trunking system provides a neat, seamless finish and is easy to install.

TECHNICAL ADVANTAGES

- **compact**
 - a limited number of products offers a solution for every situation
- **flexible**
 - suitable for horizontal and vertical mounting
 - suitable for mounting on laboratory tables
 - every trunking can be used for both wall and plinth mounting

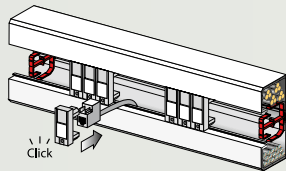
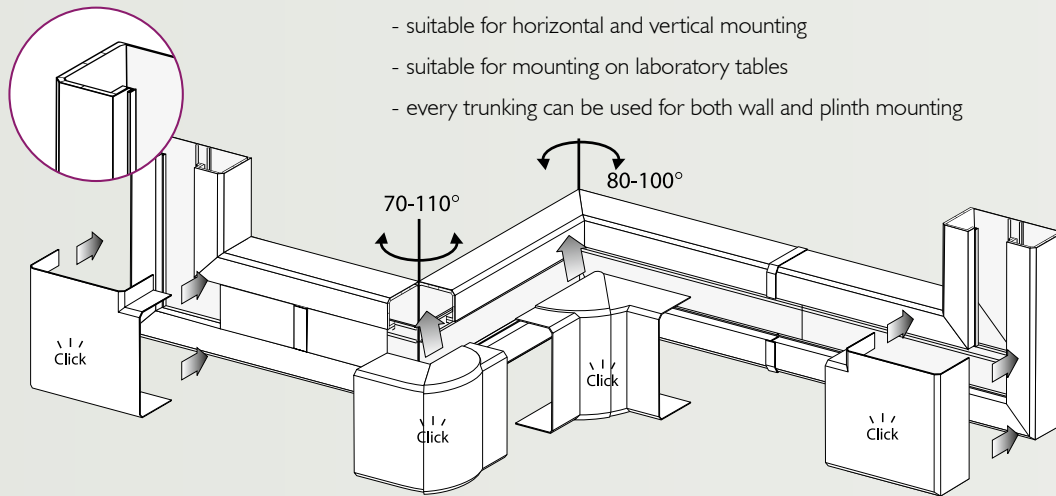

- **simple mounting**
 - 1 installer can do the job
 - base provided with drill marks every 25cm
 - large cable capacity
 - socket outlets and data outlets are clicked directly into the trunking system
- **robust and solid thanks to the double-walled concept**
- **the use of a raised frame provides additional cable capacity in single and dual trunking**
- **perfect separation of low-voltage and power current**

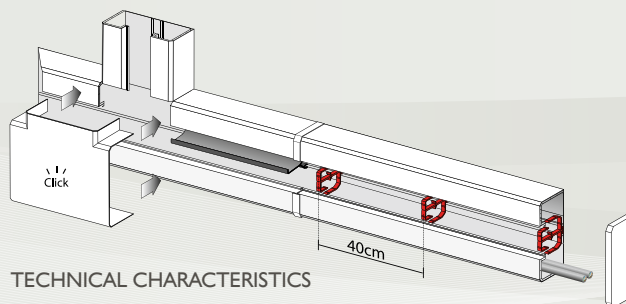

TECHNICAL CHARACTERISTICS

- **material:** PVC
- **colour:** White, RAL 9010
- **protection degree:** IP40 - IK07
- **standards and directives:** trunking and accessories comply with CE marking, CEBEC, EN50085-1, EN50085-2-1
- **Fire class M1** in accordance with NF P 92-501 and FD P 92-507

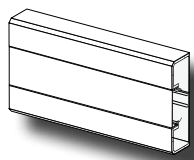
**Mini trunking 110x26mm**







Raised frame required for 1 or 2 functions.

Mini trunking**06-100**

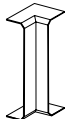
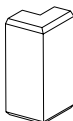
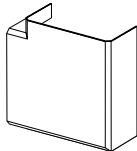
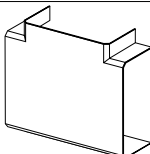
Trunking system with cover, length 2m

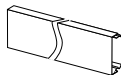
Pack: 8

Basic elements

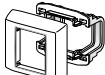
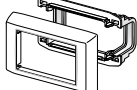
Inner angle	06-101	Pack: 15	
Outer angle	06-102	Pack: 15	
Flat angle	06-103	Pack: 5	
Flat T	06-107	Pack: 5	
End cap	06-106	Pack: 20	
Accessories			
Lid length 2m	06-190	Pack: 20	
Joint cover	06-104	Pack: 10	
Base coupler	06-105	Pack: 10	
Cable holder	06-193	Pack: 20	
Raised frame for 1 function 45x45mm	06-191	Pack: 10	
Raised frame for 2 functions: 45x45mm	06-192	Pack: 10	

Single trunking 110x50mm

Raised frame for 1 or 2 functions is optional.

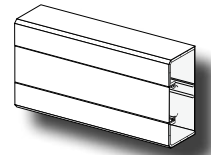

Single trunking



06-200

Trunking system with cover, length 2m
Pack: 6

Basic elements

Variable inner angle 80-100°	06-201	Pack: 10	
Variable outer angle 70-110°	06-202	Pack: 10	
Flat angle	06-103	Pack: 5	
Flat T	06-107	Pack: 5	
End cap	06-206	Pack: 20	
Accessories			
Lid length 2m	06-190	Pack: 20	
Cable divider length 2m	06-208	Pack: 20	
Joint cover	06-104	Pack: 10	
Base coupler	06-105	Pack: 10	
Cable holder	06-293	Pack: 20	
Raised frame for 1 function 45x45mm	06-191	Pack: 10	
Raised frame for 2 functions 45x45mm	06-192	Pack: 10	

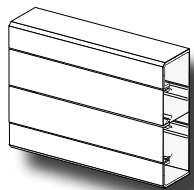

Dual trunking 160x50mm

Raised frame for 1 or 2 functions is optional.

Dual trunking







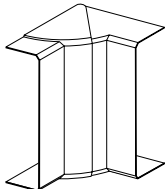
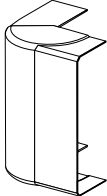
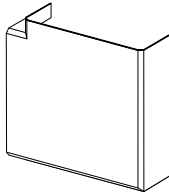

06-300

Trunking system with cover, length 2m

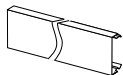
Pack: 4

Basic elements

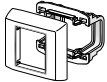
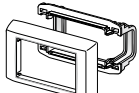
Variable inner angle 80-110°	06-301	Pack: 10	
Variable outer angle 70-110°	06-302	Pack: 10	
Flat angle	06-303	Pack: 6	
End cap	06-306	Pack: 20	
Accessories			
Lid length 2m	06-190	Pack: 20	
Cable divider length 2m	06-208	Pack: 20	
Joint cover	06-104	Pack: 10	
Base coupler	06-105	Pack: 10	
Cable holder	06-293	Pack: 20	
Raised frame for 1 function 45x45mm	06-191	Pack: 10	
Raised frame for 2 functions 45x45mm	06-192	Pack: 10	

Socket outlets 45x45mm with pin earthing, safety shutters and 1 terminal block with screw connection
 Suitable for floor boxes.



Assembled sets			
Simple	06-000	Pack: 10	
Double	06-002	Pack: 5	
3-fold	06-003	Pack: 3	
4-fold	06-004	Pack: 2	
5-fold	06-005	Pack: 2	
Simple with polarization key	06-010	Pack: 10	
2-fold with polarization key	06-012	Pack: 5	
3-fold with polarization key	06-013	Pack: 3	
Simple	06-020	Pack: 10	
Simple	06-030	Pack: 10	
Polarization key	06-099-01	Pack: 20	

Socket outlets 45x45mm with pin earthing, safety shutters and 2 terminal blocks with screw connection



Assembled sets			
Simple	06-000-20	Pack: 10	
Double	06-002-20	Pack: 10	
3-fold	06-003-20	Pack: 3	
4-fold	06-004-20	Pack: 2	
5-fold	06-005-20	Pack: 2	
Simple with polarization key	06-010-20	Pack: 10	
2-fold with polarization key	06-012-20	Pack: 10	
3-fold with polarization key	06-013-20	Pack: 3	
Polarization key	06-099-01	Pack: 20	

Socket outlets 45x45mm with pin earthing, safety shutters, 2 terminal blocks with screw connection and raised frame
 For direct mounting on mini trunking.

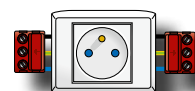

Assembled sets			
Simple	06-000-29	Pack: 5	
Double	06-002-29	Pack: 5	

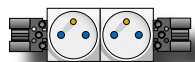
Socket outlet 45x45mm with pin earthing, safety shutters and 2 Wieland connectors GST I8
Assembled sets

Double	06-002-50	Pack: 10	
3-fold	06-003-50	Pack: 8	
4-fold	06-004-50	Pack: 2	
5-fold	06-005-50	Pack: 2	

Socket outlet 45x45mm with side earthing, safety shutters and 1 terminal block with plug-in connection
Assembled sets

Double	06-002-II	Pack: 5	
3-fold	06-003-II	Pack: 3	
4-fold	06-004-II	Pack: 2	
5-fold	06-005-II	Pack: 2	

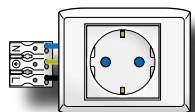
Socket outlet 45x45mm with side earthing, safety shutters and 1 terminal block with plug-in connection and raised frame

For direct mounting on mini trunking.



Assembled sets

Simple	06-000-2I	Pack: 5	
Double	06-002-2I	Pack: 5	

Socket outlet 45x45mm with side earthing, safety shutters and 2 Wieland connectors GST I8
Assembled sets





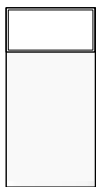

Double	06-002-5I	Pack: 10	
3-fold	06-003-5I	Pack: 8	
4-fold	06-004-5I	Pack: 2	
5-fold	06-005-5I	Pack: 2	
Double	06-012-5I	Pack: 10	
3-fold	06-013-5I	Pack: 8	
4-fold	06-014-5I	Pack: 2	
5-fold	06-015-5I	Pack: 2	

Push buttons 10A/250V AC, 22.5x45mm
Lighting units to be ordered separately.

Complete units			
Push button N.O./N.C. 10A 22.5x45mm	101-01010	Pack: 10	
Push button N.O./N.C. 10A 22.5x45mm (with LED)	101-07010	Pack: 10	
Push button N.O./N.C. 10A 22.5x45mm with illuminatable label holder	101-09010	Pack: 10	







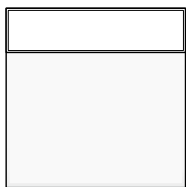

Switches 10A/250V AC 22.5x45mm / 45x45mm
Lighting units to be ordered separately.

Complete units			
Two-way switch 10A 22,5x45mm	101-01610	Pack: 10	
Two-way switch 10A 22,5x45mm (with LED)	101-07610	Pack: 10	
Two-way switch 10A 22.5x45mm with illuminatable label holder	101-09610	Pack: 10	
Two-pole two-way switch 10A 45x45mm	101-02610	Pack: 10	
Two-pole switch 10A 45x45mm	101-01210	Pack: 10	
Two-pole switch 10A 45x45mm (with LED)	101-07210	Pack: 10	
Two-pole switch 10A 45x45mm with illuminatable label holder	101-09210	Pack: 10	







Lighting units



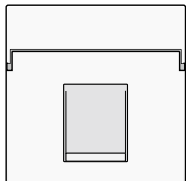



Accessories			
LED lighting unit blue, with wires (230V~)	170-37223	Pack: 10	
LED lighting unit amber colored, with wires (230V~)	170-37423	Pack: 10	
LED lighting unit red, with wires (230V~)	170-37623	Pack: 10	
LED lighting unit green, with wires (230V~)	170-37823	Pack: 10	
LED lighting unit blue, with wires (12V AC/DC)	170-37212	Pack: 10	
LED lighting unit blue, with wires (24V AC/DC)	170-37224	Pack: 10	
LED lighting unit amber colored, with wires (24V AC/DC)	170-37424	Pack: 10	

Data modules for Niko RJ outlets
1 module, single = 1 adapter + 1 finishing set
1 module, double = 2 adapters + 1 double finishing set





Modules for 1 outlet (incl. adapteur)			
Module 22.5x45mm for 1 outlet, white with transparent text field	101-65250	Pack: 10	
Module 22.5x45mm for 1 outlet, blue with transparent text field	196-65250	Pack: 10	
Module 22.5x45mm for 1 outlet, green with transparent text field	197-65250	Pack: 10	

Standard 45x45mm module, flat version

Adapter 9.1 (for Niko 650-450xx) - single	170-65901	Pack: 10	
Finishing set single with non-transparent text field	101-65100	Pack: 10	
Finishing set simple with transparent text field	101-65500	Pack: 10	
Finishing set double with non-transparent text field	101-65200	Pack: 10	
Finishing set double with transparent text field	101-65600	Pack: 10	

Standard 45x45mm module, oblique version

Adapter 9.4 (for Niko 650-450xx) - double angled	170-65904	Pack: 10	
Finishing set with transparent text field	101-65400	Pack: 10	

Niko outlets**Accessories**

650-45051
Connector RJ45 UTP cat.5E
Pack: 10



650-45055
Connector RJ45 STP cat.5E
Pack: 10



650-45061
Connector RJ45 UTP cat.6
Pack: 10



650-45066
Connector RJ45 STP cat.6
Pack: 10











650-45013
Connector RJ11 UTP
Pack: 10

Data modules for other outlets - simple

Also see 'Data communication connections for other outlets' table in Media Network chapter.

1 module = 1 adapter + 1 finishing set

Standard 45x45mm module, flat version

Adapter 1 (for AMP, Siemon, Nexans, Brandrex et al)	170-65101	Pack: 10	
Adapter 2 (for Systimax et al)	170-65201	Pack: 10	
Adapter 4.1 (for Niko 02-399-xx) - single	170-65401	Pack: 10	
Adapter 5 (for Krone, Kerpen, Radiall and Panduit et al)	170-65501	Pack: 10	
Adapter 6 (for Panduit et al)	170-65601	Pack: 10	
Adapter 7 (for CAE, Abitana, Prysmian, Molex et al)	170-65701	Pack: 10	
Finishing set single with non-transparent text field	101-65100	Pack: 10	
Finishing set simple with transparent text field	101-65500	Pack: 10	







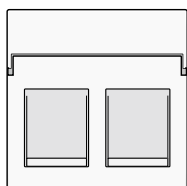
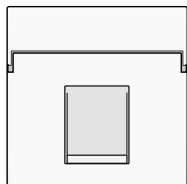

Data modules for other outlets - double

Also see 'Data communication connections for other outlets' table in Media Network chapter.





1 module = 1 adapter + 1 finishing set (ref. 170-65302, 170-65402)

1 module = 2 adapters + 1 finishing set (ref. 170-65101, 170-65201, 170-65501, 170-65601 and 170-65701)





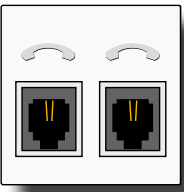

Standard 45x45mm module for 2 outlets, flat version			
Adapter 1 (for AMP, Siemon, Nexans, Brandrex et al)	170-65101	Pack: 10	
Adapter 2 (for Systimax et al)	170-65201	Pack: 10	
Adapter 3.2 (for ITT et al)	170-65302	Pack: 10	
Adapter 4.2 (for Niko 02-399-xx) - double	170-65402	Pack: 10	
Adapter 5 (for Krone, Kerpen, Radiall and Panduit et al)	170-65501	Pack: 10	
Adapter 6 (for Panduit et al)	170-65601	Pack: 10	
Adapter 7 (for CAE, Abitana, Prysmian, Molex et al)	170-65701	Pack: 10	
Finishing set double with non-transparent text field	101-65200	Pack: 10	
Finishing set double with transparent text field	101-65600	Pack: 10	

Telephone sockets 45x45mm

Complete units			
5-pin telephone socket Belgium	101-69002	Pack: 10	
Telephone socket 2 x RJ11 parallel	101-69032	Pack: 10	
ADSL/VDSL splitter RJ11	101-69092	Pack: 10	
Telephone socket France	101-79072	Pack: 10	





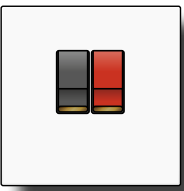

Audio connections 45x45mm

Complete units			
2 x CINCH	101-69716	Pack: 10	
3 x CINCH	101-69717	Pack: 10	
Double loudspeaker socket	101-69703	Pack: 10	
Simple loudspeaker socket	101-69803	Pack: 10	



TV/FM sockets 45x45mm

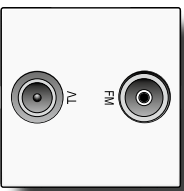

Complete units			
Simple male coax	101-69121	Pack: 10	
2 x simple coax EDU TV + FM	101-69501	Pack: 10	
2 x multiple coax GEDU TV + FM	101-69601	Pack: 10	
2 x simple coax EDU TV + FM Telenet Intercable	101-69532	Pack: 10	
2 x simple coax + satellite	101-69552	Pack: 10	





Orientation lighting 45x45mm

Complete units

Orientation lighting with white LEDs, 830LUX, 6500K	170-38002	Pack: 10	
Orientation lighting with blue LEDs, 270 LUX	170-38102	Pack: 10	

TRUNKING SYSTEM



110 x 26mm

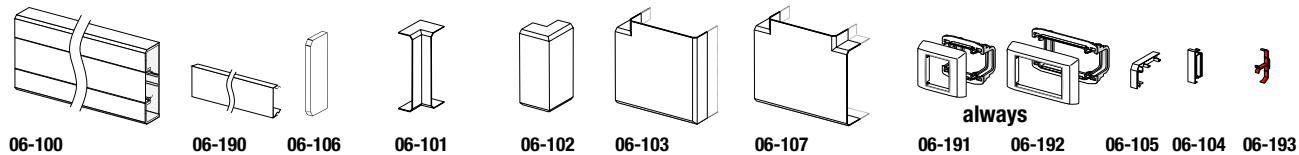

110 x 50mm

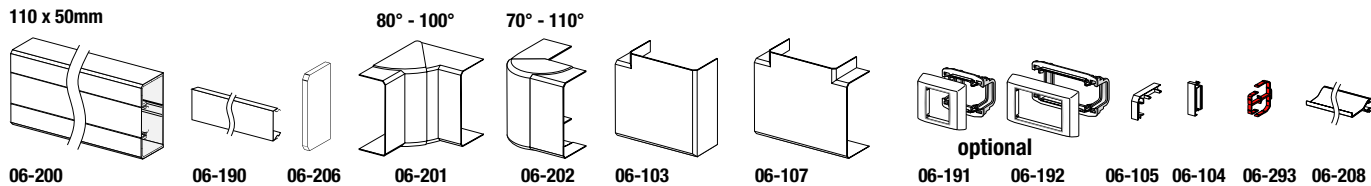

160 x 50mm

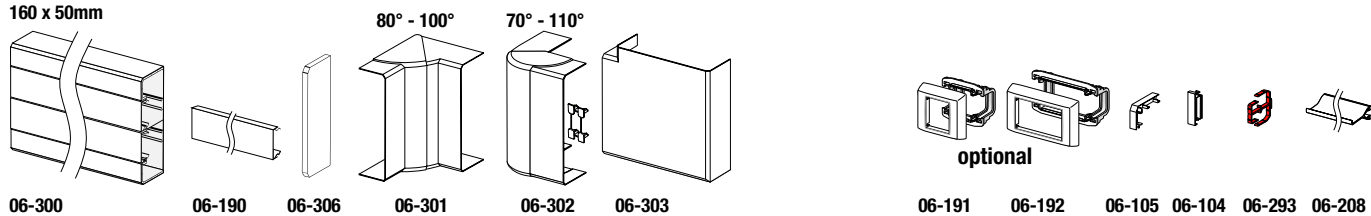

la

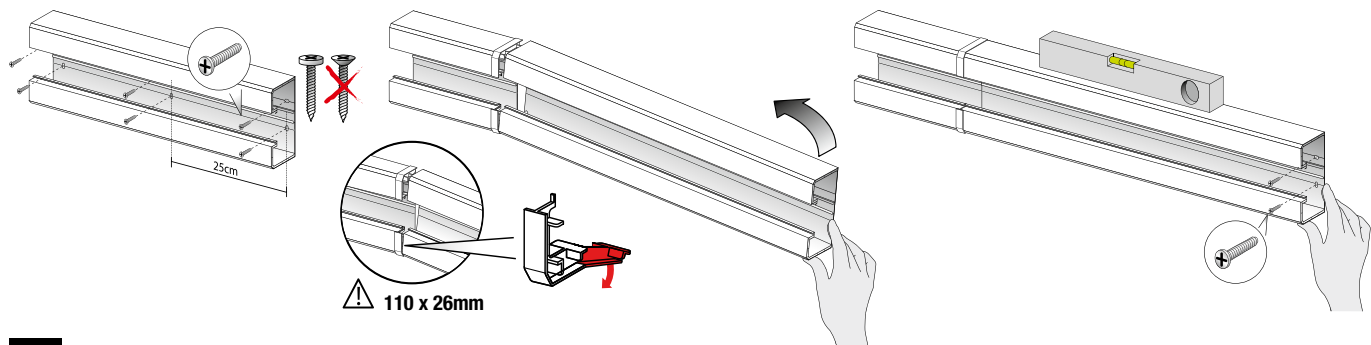

lb

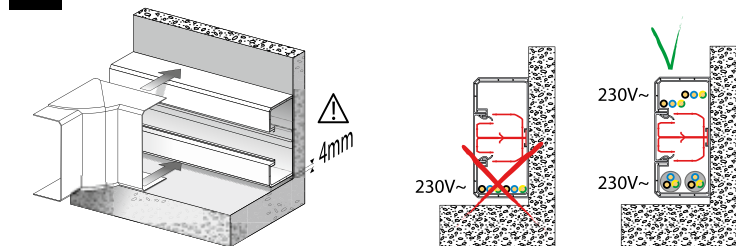

TRUNKING SYSTEM

2

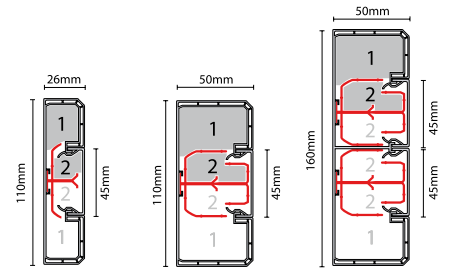
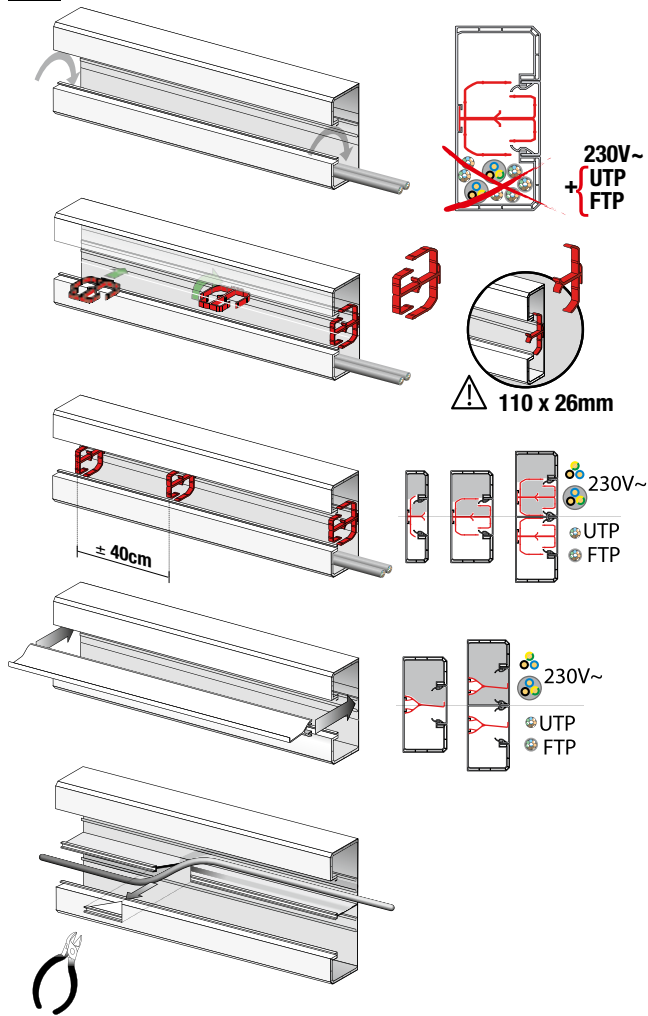

		110x26mm	110x50mm	160x50mm
230V~	ZONE 1	3	7	7
3 x 2,5mm ²	ZONE 2	2	4	4
UTP	ZONE 1	7	21	24
ø 6mm	ZONE 2	6	12	14
FTP	ZONE 1	6	15	16
ø 8mm	ZONE 2	3	8	7
ZONE 1		525mm ²	1250mm ²	1250mm ²
ZONE 2		275mm ²	662mm ²	662mm ²

3

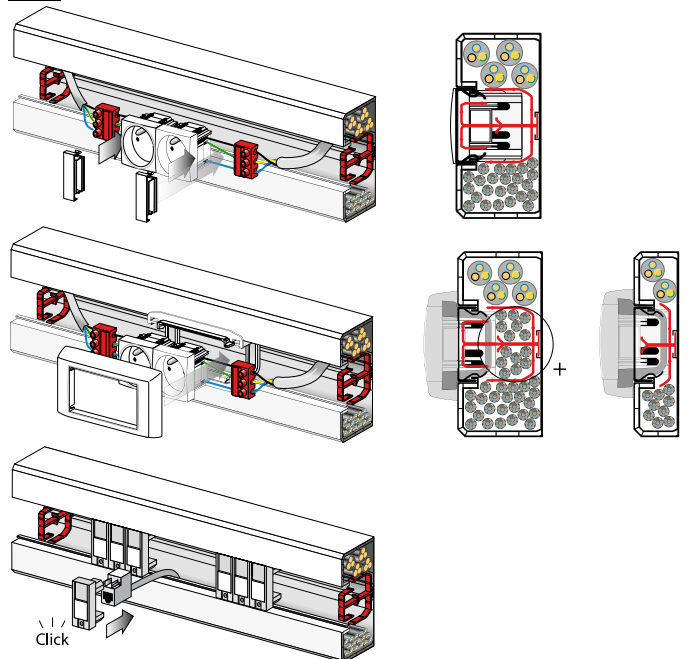

4

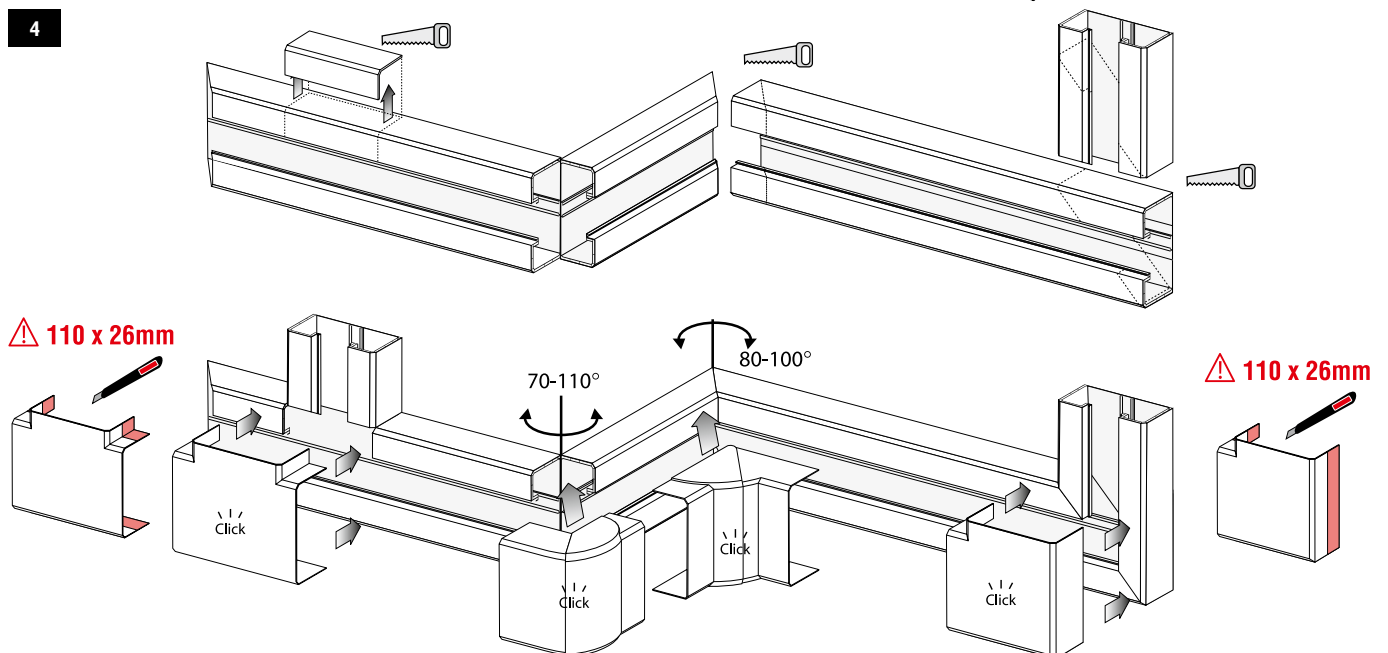

TRUNKING SYSTEM

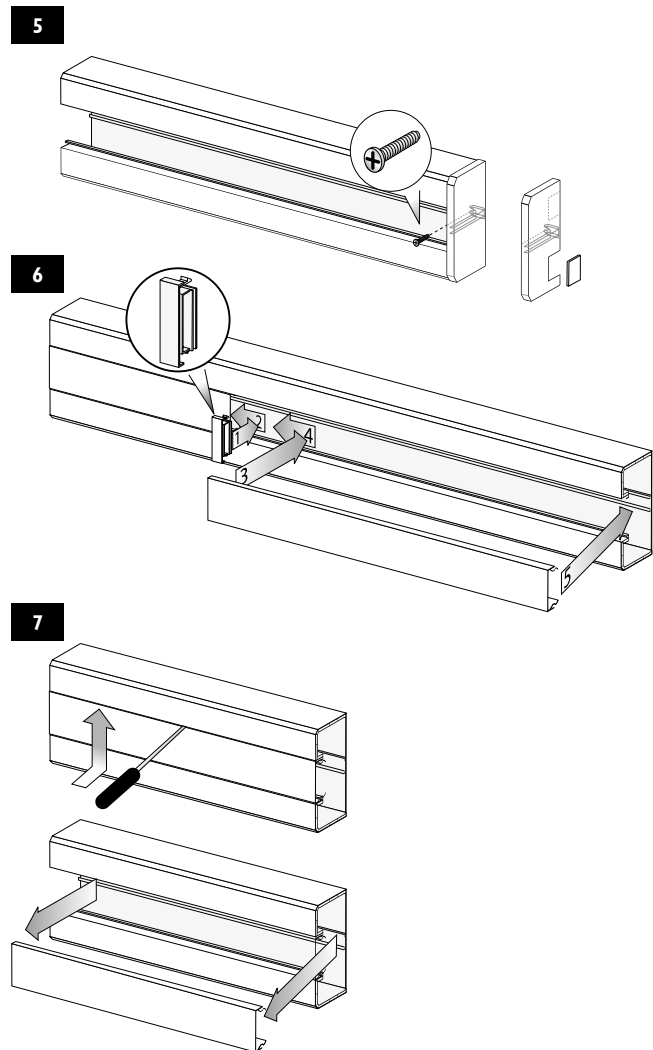

TECHNICAL SPECIFICATIONS TRUNKING SYSTEM

- Material: PVC
- Impact resistance: complies with IK07 (EN 50102)
- Insulation resistance: $\geq 100M\Omega$
- Usage temperature: transport: $-25^{\circ}C$ to $60^{\circ}C$
Installation: $-5^{\circ}C$ to $60^{\circ}C$
- IP40: protection against intrusion of solids $\varnothing > 1mm$
- 230V~ 16A
- Fire class M1 according to NF P 92-501 and FD P 92-507