

## MOUNTING SYSTEMS

---

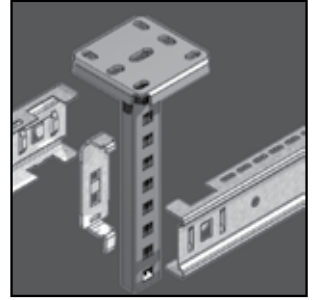

## MOUNTING SYSTEMS

	Survey of the system	5-239
<b>THREADED ROD FIXING</b>		
FL	Fixing clamp for threaded rod	5-241
PB	Ceiling bracket	5-241
PBR	Adjustable ceiling bracket	5-241
SDBG	Steeldeck bracket	5-242
VFCB	Central suspension bracket for VF/VFL	5-242
OBG	Upper bracket	5-243
BG	Inside bracket	5-243
DR 15*30	Supporting profile	5-244
DR 21*41	Supporting profile	5-244
<b>BRACKETS</b>		
VMB	Floor and wall bracket	5-244
OBZ 130	Open suspension bracket	5-245
OBZ 180	Open suspension bracket	5-245
COMEGACL 170	Snap-in suspension bracket for VF/VFL	5-246
COMEGA 170	Open suspension bracket	5-246
COMEGA 290	Open suspension bracket	5-247
CCLTI	Bracket KBSTI for wall and ceiling	5-247
<b>CANTILEVER</b>		
LOMEGACL 150	Snap-in wall bracket for VF/VFL	5-248
LOMEGA 150	Bracket/ceiling profile	5-248
VOMEGA	Jointing piece	5-249
MBZ	Wall support	5-249
WS	Wall support	5-250
KCL	Bracket clips for HSLECL	5-250
WKS	Screwed bracket	5-251
WKSS	Adjustable bracket	5-252
WK	Joined bracket	5-253
WKM	Heavy joined bracket	5-253
WKZ	Extra heavy joined bracket	5-254
HKI	Joined clamping bracket	5-254
HKIZ	Extra heavy joined clamping bracket	5-255
<b>CEILING PROFILES</b>		
KPCL	Headplate clips	5-255
MPCL	Assembly profile clips	5-256
HSLECL	Single Ceiling profile clips	5-256
CLHS	Adapter clips for HSLECL	5-257
HSLDCL	Double Ceiling profile clips	5-257
HSME	Single ceiling profile	5-258
HSMU	Ceiling profile medium heavy	5-258
TSU 50	Spacer HSMU 50	5-259
HSMD	Double ceiling profile	5-259
HSIZ	Heavy ceiling profile	5-260
<b>ACCESSORIES CEILING PROFILES</b>		
DOP 41*41	Protection cap for pendant 41x41	5-260
DOPHSLECL	Protection cap for HSLECL	5-261
DOPHSMD	Protection cap for HSMD	5-261
SKP	Adjustable head plate	5-261
<b>IPN ACCESSORIES</b>		
IPN 80 SL	Perforated I-profile	5-262
PR 80	Protection cap for IPN 80 SL	5-262
IPL 06	Headplate for IPN 80 SL	5-262
IPL 10	Headplate for IPN 80 SL	5-263
SKIPN	Hinged headplate for IPN 80 SL	5-263
KIPN	Jointing piece for IPN 80 SL	5-263
DKIPN	Cross jointing plate for IPN 80 SL	5-264
KIPN	Mounting piece IPN 80 SL	5-264
WVPIP	Universal fixing for IPN 80 SL	5-264
<b>PROFILES</b>		
L 25	L-profile	5-265
L 25*50	L-profile	5-265

L 50*50	L-profile	5-265
Z 25	Z-profile	5-266
Z 50	Z-profile	5-266
MP 41*21*2.50 SL	Assembly profile Hot dip	5-266
MPZ 41*21*2.50 SL	Assembly profile	5-267
MPZ 41*21*1.50 SL	Assembly profile HD	5-267
MP 41*41*2.50 SL	Assembly profile	5-267
MPZ 41*41*2.50 SL	Assembly profile	5-268
MP 41*41*2.50 DGL	Assembly profile	5-268
MPZ 41*41*2.50 DGL	Assembly profile	5-268
<b>VS MOUNTING</b>		
VS 41	Assembly accessorie	5-269
<b>MOUNTING ACCESSORIES</b>		
TIM	Threaded rod (DIN 975)	5-270
VM 6334	Coupling nut (DIN 6334)	5-270
GM	Sliding nut for supporting profile	5-270
GM 41	Sliding nut for supporting profile	5-271
GMV 41	Sliding nut spring supporting profile	5-271
B	Bolt (DIN 933)	5-271
RBK	Toothed round head bolt	5-272
M	Nut (DIN 934)	5-272
VM	Nut and Bolt	5-272
VMK	Toothed round head bolt/nut	5-273
RB	Bolt	5-273
RM	Flange nut (DIN 6923)	5-273
CRO	Flat giant washer (DIN 9021)	5-274
RO	Giant washer (DIN 125-1 A)	5-274
VSZ	Galvaspray 400 ml	5-274
RBS	Edge protection	5-275
	TECHNICAL INFORMATION	5-277

## LOAD CAPACITY OF CEILING PROFILES

Ceiling Profiles	Moment M (Nm)	Maximum Load S (daN)
MP + KPCL	160	300
HSLECL	180	300
HSLDCL	590	500
HSME	480	800
HSMU 50	430	1000
HSMD	1850	1500
HSIZ	2150	2000

Tested according IEC 61537

F = Load or force onto the bracket

a = Distance from the load to the centerline of the ceiling profile (m)

L = Length of the ceiling profile (m)

M = Moment (daNm) = F x a

f = Deflection of the ceiling profile (mm)

Maximum permissible deflection = L/20 or 5% of the length

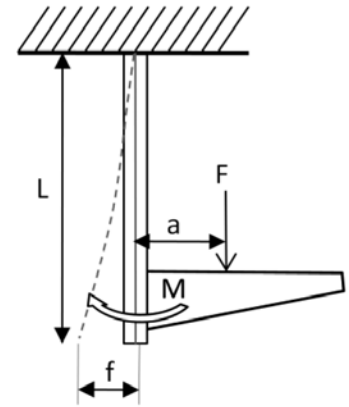

## MULTIPLE LOADS

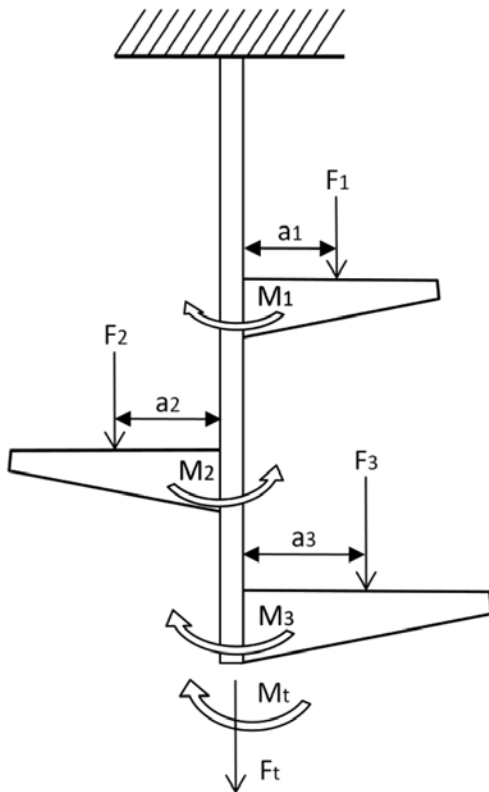

$$F_t = F_1 + F_2 + F_3$$

Total load = sum of all loads

$$M_t = (M_1 + M_3) - M_2 = (F_1 \times a_1 + F_3 \times a_3) - (F_2 \times a_2)$$

Total Moment = sum of all Moments to the left – sum of all Moments to the right

The following 2 conditions should always been met :

### Condition 1 :

Total Moment ( $M_t$ ) ≤ Max. Moment of the ceiling profile (M- of Moment-values, see tabel)

and

### Condition 2 :

Total Load or Force ( $F_t$ ) ≤ Max. Load of the ceiling profile (S-values, see tabel)

Remark:

When symmetrical load is perfect :  $M_t = 0$

In that case, only the second condition is valid : Total Load ( $F_t$ ) ≤ Max. Load of the ceiling profile (S)

**WEIGHT PER SUPPORT**

The following formula is used:

$$\text{Weight per support (daN)} = (\text{cable load / meter} + \text{own weight of the cable support system / meter}) \times \text{support distance}$$

**EXAMPLE 1 : Cable tray KBSI 60\*300\*1.25 mounted on WKS 300. What is the maximum support or span distance ?**

Calculated maximum cable load = 45 daN/m (45 kg/m)

Own weight of the cable tray KBSI 60\*300\*1.25 = 3,7 daN/m (3,70 kg/m)

Max. load support WKS 300 = 130 daN

Weight per support (45 daN/m + 3,7 daN/m) x support distance = 130 daN

Max. support distance = 130 daN / (44 daN/m + 3,7 daN/m) = 2,7 m

Remark : The load diagram of the cable support system shows that a load of 44 daN/m of 44 kg/m is no problem on such a support distance.

**EXAMPLE 2 : Cable ladder KLIG 100\*400, support distance 4m. Which support will we chose ?**

Calculated maximum cable load = 68 daN/m (68 kg/m)

Remark : The load diagram of the KLIG 100 shows that the load of 68 daN/m at the support distance of 4 m is no problem.

Own weight of cable ladder KLIG 100\*400 = 6,43 daN/m (6,43 kg/m)

Weight per support : (68 daN/m + 6,43 daN/m) x 4 = 297,7 daN

Remark : The maximum load values for supports shows that a WKS 400 is not strong enough (Max. load is 130 daN). WK 400 is a better choice, as this support can carry a maximum of 430 kg/m.

## CABLE LOAD

The weight the cable tray or cable ladder can bear, can be calculated on the basis of the weight of the desired cables, specified by the cable manufacturer.

The maximum number of cables is limited by the cross-section (fill area) of the cable tray / ladder.

In no case should the load be higher than indicated in the load diagram of the desired cable support system.

On the basis of the following formula, the approximate cable weight can be calculated :

$$\text{Cable weight per meter (daN/m)} = \text{useful cross-section of the cable support system (mm}^2\text{)} \times \frac{0,0025 \text{ daN}}{\text{m} \times \text{mm}^2}$$

$\frac{0,0025 \text{ daN}}{\text{m} \times \text{mm}^2}$  is based on the specific gravity of copper and the average amount of insulator and air per intersection.

### EXAMPLE 1 : Cable tray KBSI 60\*300\*1.25

Useful width = 300 mm

Useful height = 60 mm

Useful fill area : 300 mm x 60 mm = 18000 mm<sup>2</sup>

**Cable weight per meter (daN/m) : 18000 mm<sup>2</sup> x  $\frac{0,0025 \text{ daN}}{\text{m} \times \text{mm}^2}$  = 45 daN/m (45 kg/m)**

Rule of thumb :

A cable tray of 60 mm height can carry 15 kg cable per running meter per 100 mm width.

KBSI 60\*300 is designed to carry 15x3 = 45 kg/m.

### EXAMPLE 2 : Cable ladder KLIIG 100\*400

Useful inner width = 352 mm

Useful inner height = 77 mm

Useful fill area : 352 mm x 77 mm = 27104 mm<sup>2</sup>

**Cable weight per meter (daN/m) : 27104 mm<sup>2</sup> x  $\frac{0,0025 \text{ daN}}{\text{m} \times \text{mm}^2}$  = 69 daN/m (69 kg/m)**

## OVERVIEW OF MAXIMUM LOAD PER MOUNTING SYSTEM

### THREADED ROD FIXING

Reference	Max. load (in daN)
FL 1	250
FL 2	250
FL 3	350

Reference	Max. load (in daN)
TIM 6	300
TIM 8	550
TIM 10	900
TIM 12	1300

Reference	Max. load (in daN)
OBG 050	200
OBG 075	200
OBG 100	200
OBG 150	200
OBG 200	200
OBG 250	150
OBG 300	150
OBG 400	90

Reference	Max. load (in daN)
DR 15*30	100
DR 21*41	150

Reference	Max. load (in daN)
BG 60*075	200
BG 60*100	200
BG 60*150	200
BG 60*200	150
BG 60*250	120
BG 60*300	90
BG 60*400	30

Reference	Max. load (in daN)
PB	250
PBR	170
SDBG	300

### BRACKETS

Reference	Max. load (in daN)
COMEGA 170*150	60
COMEGA 170*200	60
COMEGA 170*300	50
COMEGA 170*400	40

Reference	Max. load (in daN)
COMEGACL 170*150	60
COMEGACL 170*200	60
COMEGACL 170*300	50
COMEGACL 170*400	40

Reference	Max. load (in daN)
COMEGA 290*100	70
COMEGA 290*150	60
COMEGA 290*200	60
COMEGA 290*250	50
COMEGA 290*300	50
COMEGA 290*400	40

Reference	Max. load (in daN)
OBZ 130*075	80
OBZ 130*100	40
OBZ 130*150	50
OBZ 130*200	30
OBZ 130*250	50
OBZ 130*300	40
OBZ 130*400	30

Reference	Max. load (in daN)
OBZ 180*075	50
OBZ 180*100	30
OBZ 180*150	30
OBZ 180*200	30
OBZ 180*250	40
OBZ 180*300	40
OBZ 180*400	20

Reference	Max. load (in daN)	
	Wall	Ceiling
CCLTI 150	107	63
CCLTI 200	80	47
CCLTI 250	150	110
CCLTI 300	133	83
CCLTI 400	100	62

Reference	Max. load (in daN)
VMB	200

### CANTELEVER

Reference	Max. load (in daN)
WS 100	70
WS 150	60
WS 200	60
WS 250	60
WS 300	50
WS 400	50
WS 500	40
WS 600	30

Reference	Max. load (in daN)
LOMEGA 150*100	110
LOMEGA 150*150	100
LOMEGA 150*200	90
LOMEGA 150*250	80
LOMEGA 150*300	70
LOMEGA 150*400	50
LOMEGA 150*500	40
LOMEGA 150*600	30

Reference	Max. load (in daN)
LOMEGACL 150*150	100
LOMEGACL 150*200	90
LOMEGACL 150*300	70
LOMEGACL 150*400	50

Reference	Max. load (in daN)
MBZ	40

Reference	Max. load (in daN)
KCL 100	110
KCL 150	100
KCL 200	100
KCL 250	90
KCL 300	90
KCL 400	70
KCL 500	60
KCL 600	50

Reference	Max. load (in daN)
WKS 100	110
WKS 150	110
WKS 200	120
WKS 250	120
WKS 300	130
WKS 400	130
WKS 500	140
WKS 600	150

Reference	Max. load (in daN)
WKSS 100	110
WKSS 150	110
WKSS 200	120
WKSS 250	120
WKSS 300	100
WKSS 400	75
WKSS 500	60
WKSS 600	50

Reference	Max. load (in daN)
WK 100	120
WK 150	230
WK 200	340
WK 250	450
WK 300	320
WK 400	430
WK 500	390
WK 600	350
WK 800	280
WK 1000	200

Reference	Max. load (in daN)
HKI 100	300
HKI 150	310
HKI 200	330
HKI 250	340
HKI 300	360
HKI 400	370
HKI 500	380
HKI 600	410
HKI 800	370
HKI 1000	330

Reference	Max. load (in daN)
WKZ 300	750
WKZ 400	740
WKZ 500	720
WKZ 600	710

Reference	Max. load (in daN)
HKIZ 300	900
HKIZ 400	910
HKIZ 500	920
HKIZ 600	930

Reference	Max. load (in daN)
WKM 100	600
WKM 200	620
WKM 300	620
WKM 400	610







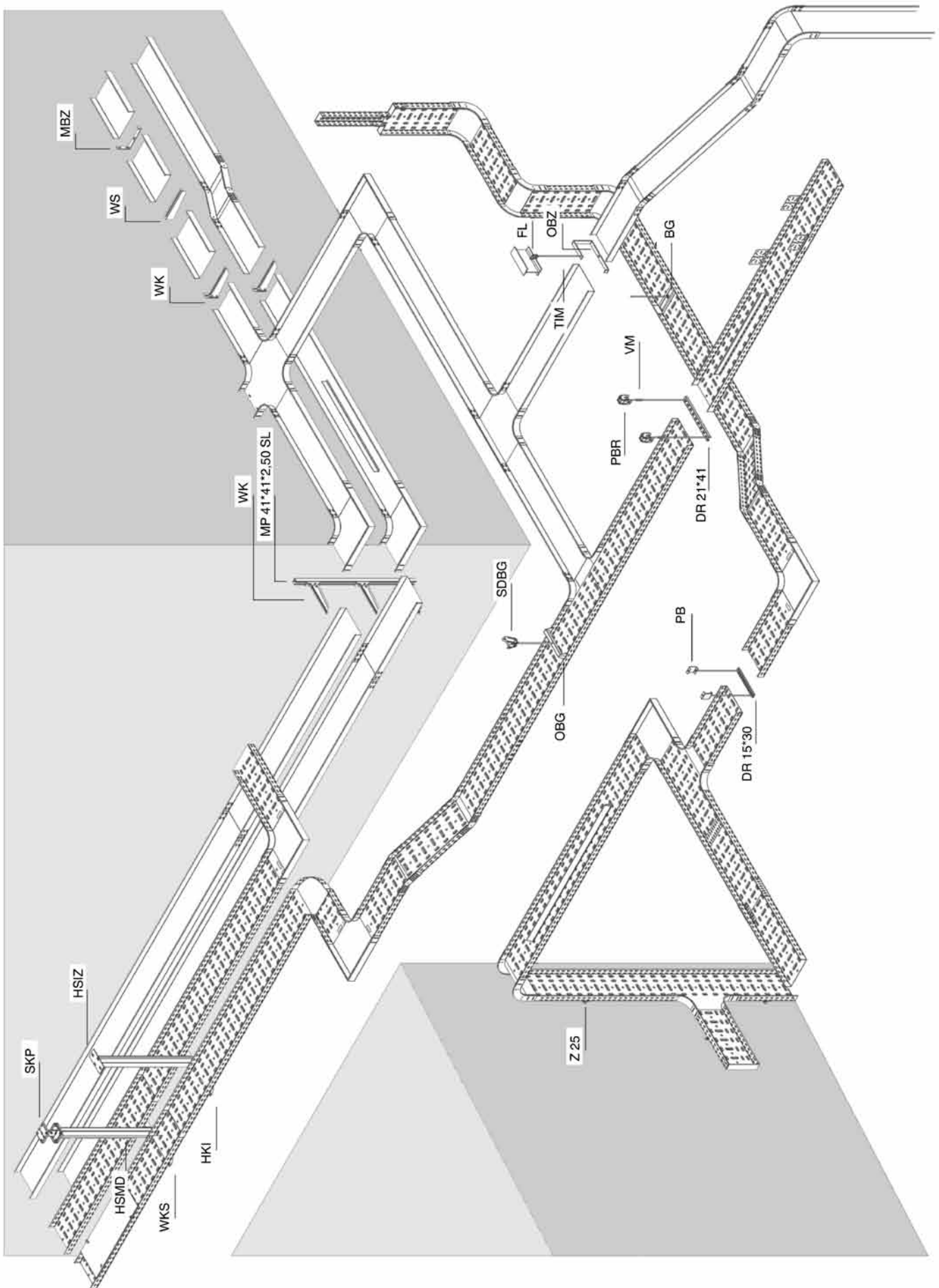

**FL**

**Fixing clamp for threaded rod**

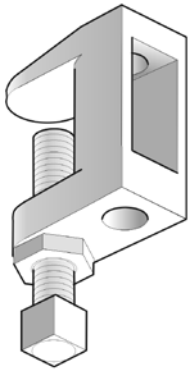

Standard finish

Electro zinc-plated

Reference	Max. load (in daN)	Clamp range
FL 1	250	0-22 mm
FL 2	250	0-19 mm
FL 3	350	5-25 mm

HD	Reference	↑ mm	↔ mm	↔ mm	↔ mm	kg/piece	⊞	Stock	Unit
-	<b>FL 1</b>	-	-	M8	-	0.140	50	✓	piece
-	<b>FL 2</b>	-	-	M10	-	0.150	50	✓	piece
-	<b>FL 3</b>	-	-	M12	-	0.210	50	✓	piece

The fixing clamp is useful for I-profiles which are placed horizontally and for I-profiles with a certain angle of inclination. The fixing clamp is delivered with adjusting screw and suitable lock-nut included. Threaded rod should be ordered separately.

**PB**

**Ceiling bracket**

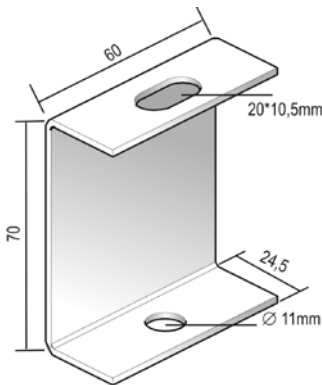

On Demand

Powder coating / Duplex System

Max. load

250 daN

Standard finish

Pre-galvanised

HD	Reference	↑ mm	↔ mm	↔ mm	↔ mm	kg/piece	⊞	Stock	Unit
-	<b>PB</b>	70	-	-	-	0.100	48	✓	piece

Threaded rod TIM 8 or TIM 10 to be ordered separately.

**PBR**

**Adjustable ceiling bracket**

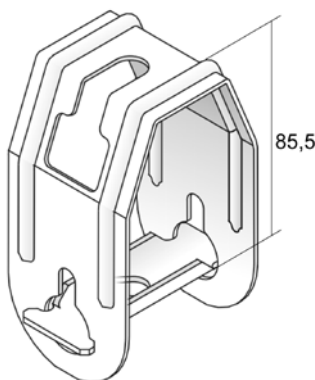

Ideal for a light inclining roof construction.

Max. load

170 daN

Standard finish

Pre-galvanised

HD	Reference	↑ mm	↔ mm	↔ mm	↔ mm	kg/piece	⊞	Stock	Unit
-	<b>PBR</b>	-	-	-	-	0.140	48	✓	piece

Threaded rod TIM 8 or TIM 10 to be ordered separately.

**SDBG**

**Steeldeck bracket**

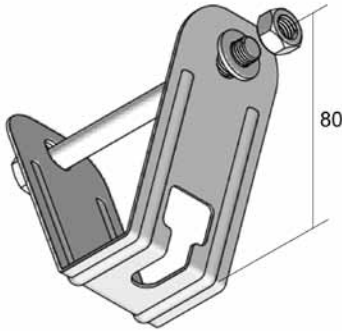

For fixation to steel roof constructions.

Max. load	300 daN
Standard finish	Pre-galvanised

HD	Reference	↑ mm	↔ mm	↔ mm	↔ mm	kg/piece	📦	Stock	Unit
-	<b>SDBG</b>	-	-	-	-	0.200	48	✓	piece

Delivered complete with bolt B 10\*110, nut M 10 and washer RO 10.

**VFCB**

**Central suspension bracket for VF/VFL**



For threaded rod suspension M6/M8.

On Demand	Powder coating / Duplex System
Standard finish	Pre-galvanised
Optional finish 1	Hot-dip galvanised

HD	Reference	↑ mm	↔ mm	↔ mm	↔ mm	kg/set	📦	Stock	Unit
HD	<b>VFCB</b>	-	-	-	-	0.070	30	✓	set

Per set (2 pieces)

Can be used for wire cable trays VFL/VF 35\*100, VFL/VF 60\*100 and VFL/VF 60\*150. Threaded rod TIM 6 or TIM 8 and nut M 6 or M 8 should be ordered separately.

## OBG

### Upper bracket

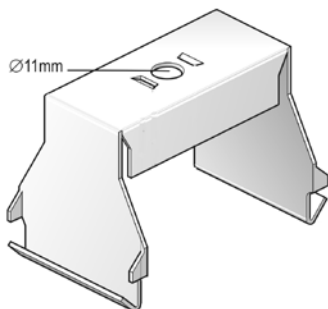

To mount cable trays with partition.

On Demand	Powder coating / Duplex System
Standard finish	Pre-galvanised
Optional finish 1	Hot-dip galvanised

	Max. load (in daN)
OBG 050	200
OBG 075	200
OBG 100	200
OBG 150	200
OBG 200	200
OBG 250	150
OBG 300	150
OBG 400	90

HD	Reference	↑ mm	↔ mm	↔ mm	↔ mm	kg/piece	⊞	Stock	Unit
HD	<b>OBG 050</b>	64	55	-	-	0.100	12	✓	piece
HD	<b>OBG 075</b>	64	80	-	-	0.130	12	✓	piece
HD	<b>OBG 100</b>	64	105	-	-	0.140	12	✓	piece
HD	<b>OBG 150</b>	64	155	-	-	0.190	12	✓	piece
HD	<b>OBG 200</b>	64	205	-	-	0.220	12	✓	piece
HD	<b>OBG 250</b>	64	255	-	-	0.270	12	✓	piece
HD	<b>OBG 300</b>	64	305	-	-	0.310	6	✓	piece
HD	<b>OBG 400</b>	64	405	-	-	0.390	6	✓	piece

To be mounted with threaded rod TIM 8 or TIM 10.

## BG

### Inside bracket

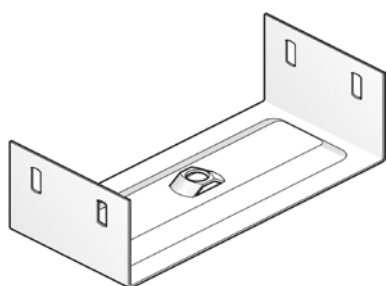

On Demand	Height 35 mm
On Demand	Powder coating / Duplex System
Standard finish	Pre-galvanised
Optional finish 1	Hot-dip galvanised

	Width	Max. load (in daN)
BG 075		200
BG 100		200
BG 150		200
BG 200		150
BG 250		120
BG 300		90
BG 400		30

HD	Reference	↑ mm	↔ mm	↔ mm	↔ mm	kg/piece	⊞	Stock	Unit
HD	<b>BG 60*075</b>	56	70	-	-	0.200	12	✓	piece
HD	<b>BG 60*100</b>	56	95	-	-	0.210	12	✓	piece
HD	<b>BG 60*150</b>	56	145	-	-	0.270	12	✓	piece
HD	<b>BG 60*200</b>	56	195	-	-	0.330	12	✓	piece
HD	<b>BG 60*250</b>	56	245	-	-	0.380	12	✓	piece
HD	<b>BG 60*300</b>	56	295	-	-	0.430	6	✓	piece
HD	<b>BG 60*400</b>	56	395	-	-	0.530	6	✓	piece

To be fixed with threaded rod TIM 8 or TIM 10.  
Delivered with premounted nut M 10

**DR 15\*30**

**Supporting profile**

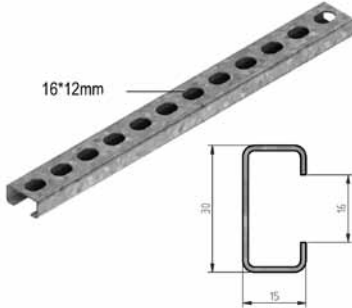

On Demand	Powder coating / Duplex System
Max. load	100 daN
Standard finish	Pre-galvanised
Optional finish 1	Hot-dip galvanised

HD	Reference	↑ mm	↔ mm	↔ mm	↔ mm	kg/piece	⊞	Stock	Unit
HD	<b>DR 100</b>	15	30	-	100	0.060	50	✓	piece
HD	<b>DR 150</b>	15	30	-	150	0.080	50	✓	piece
HD	<b>DR 200</b>	15	30	-	200	0.110	50	✓	piece
HD	<b>DR 250</b>	15	30	-	250	0.130	50	✓	piece
HD	<b>DR 300</b>	15	30	-	300	0.160	50	✓	piece
HD	<b>DR 350</b>	15	30	-	350	0.190	50	✓	piece
HD	<b>DR 15*30*2000</b>	15	30	-	2000	0.600	1		m

To be fixed with two threaded rods TIM 8 + nut M 8 + CRO 8.  
Always order the width of the cable tray + 50 mm.

**DR 21\*41**

**Supporting profile**

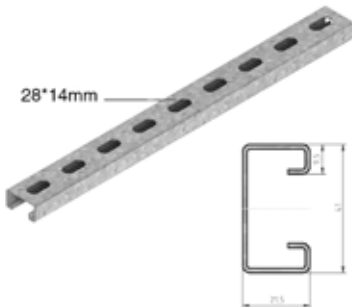

On Demand	Powder coating / Duplex System
Max. load	150 daN
Standard finish	Pre-galvanised
Optional finish 1	Hot-dip galvanised

HD	Reference	↑ mm	↔ mm	↔ mm	↔ mm	kg/piece	⊞	Stock	Unit
HD	<b>DR 450</b>	21	41	-	450	0.500	6	✓	piece
HD	<b>DR 550</b>	21	41	-	550	0.620	6	✓	piece
HD	<b>DR 650</b>	21	41	-	650	0.700	6	✓	piece

To be fixed with two threaded rods TIM 10 + nut M 10 + CRO 10.  
Always order the width of the cable tray + 50 mm.

**VMB**

**Floor and wall bracket**

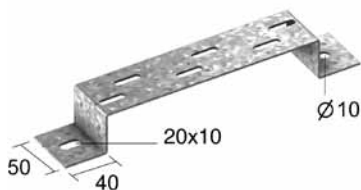

Suitable as floor-, wall-, and suspension bracket.	
On Demand	Powder coating / Duplex System
Max. load	200 daN
Standard finish	Pre-galvanised
Optional finish 1	Hot-dip galvanised

HD	Reference	↑ mm	↔ mm	↔ mm	↔ mm	kg/piece	⊞	Stock	Unit
HD	<b>VMB 100</b>	40	100	-	-	0.190	30	✓	piece
HD	<b>VMB 150</b>	40	150	-	-	0.220	30	✓	piece
HD	<b>VMB 200</b>	40	200	-	-	0.260	30	✓	piece
HD	<b>VMB 300</b>	40	300	-	-	0.330	30	✓	piece
HD	<b>VMB 400</b>	40	400	-	-	0.390	30	✓	piece
HD	<b>VMB 500</b>	40	500	-	-	0.460	30	✓	piece
HD	<b>VMB 600</b>	40	600	-	-	0.530	30	✓	piece

Floor bracket and suspension bracket : to mount with VFCL.  
Wall bracket : to mount with VFK

## OBZ 130

### Open suspension bracket

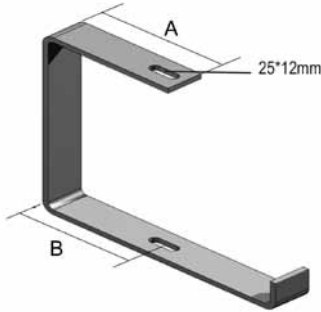

Useful for direct mounting to the ceiling or with threaded rod TIM 8 or TIM 10.

On Demand	Powder coating / Duplex System
Standard finish	Electro zinc-plated
Optional finish 1	Hot-dip galvanised

	Max. load (in daN)	A	B
OBZ 130*075	80	64	42.5
OBZ 130*100	40	80	59.5
OBZ 130*150	50	105	84.5
OBZ 130*200	30	130	109.5
OBZ 130*250	50	155	134.5
OBZ 130*300	40	180	159.5
OBZ 130*400	30	230	209.5

HD	Reference	↑ mm	↔ mm	↔ mm	↔ mm	kg/piece	⊞	Stock	Unit
HD	OBZ 130*075	132	102	-	-	0.340	12	✓	piece
HD	OBZ 130*100	132	125	-	-	0.380	12	✓	piece
HD	OBZ 130*150	132	177	-	-	0.570	12	✓	piece
HD	OBZ 130*200	132	227	-	-	0.670	12	✓	piece
HD	OBZ 130*250	132	281	-	-	1.020	6	✓	piece
HD	OBZ 130*300	132	331	-	-	1.180	6	✓	piece
HD	OBZ 130*400	132	431	-	-	1.600	6	✓	piece

Fixation of the cable tray by VM 6\*20.

Max. load (in daN): uniformly distributed over complete width of cantilever brackets.

## OBZ 180

### Open suspension bracket

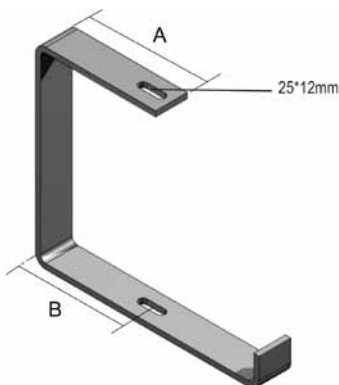

Useful for direct mounting to the ceiling or with threaded rod TIM 8 or TIM 10.

On Demand	Powder coating / Duplex System
Standard finish	Electro zinc-plated
Optional finish 1	Hot-dip galvanised

	Max. load (in daN)	A	B
OBZ 180*075	50	64	42.5
OBZ 180*100	30	80	59.5
OBZ 180*150	30	105	84.5
OBZ 180*200	30	130	109.5
OBZ 180*250	40	155	134.5
OBZ 180*300	40	180	159.5
OBZ 180*400	20	230	209.5

HD	Reference	↑ mm	↔ mm	↔ mm	↔ mm	kg/piece	⊞	Stock	Unit
HD	OBZ 180*075	182	102	-	-	0.390	12	✓	piece
HD	OBZ 180*100	182	125	-	-	0.440	12	✓	piece
HD	OBZ 180*150	182	177	-	-	0.630	12	✓	piece
HD	OBZ 180*200	182	227	-	-	0.720	12	✓	piece
HD	OBZ 180*250	182	281	-	-	1.100	6	✓	piece
HD	OBZ 180*300	182	331	-	-	1.270	6	✓	piece
HD	OBZ 180*400	182	431	-	-	1.500	6	✓	piece

Fixation of the cable tray by VM 6\*20.  
 Max. load (in daN): uniformly distributed over complete width of cantilever brackets.

**COMEGACL 170**



**Snap-in suspension bracket for VF/VFL**

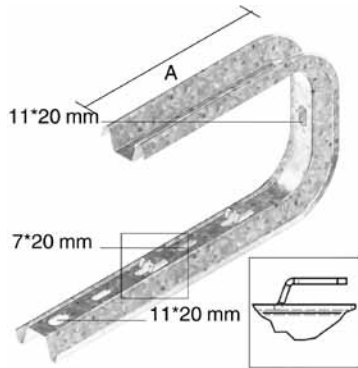

Useful for direct mounting to the ceiling or with threaded rod TIM 8 or TIM 10.

On Demand	Powder coating
Standard finish	Pre-galvanised
Optional finish 1	Hot-dip galvanised

	Max. load (in daN)	A
COMEGACL 170*150	60	147
COMEGACL 170*200	60	172
COMEGACL 170*300	50	222
COMEGACL 170*400	40	272

HD	Reference	↑ mm	↔ mm	↔ mm	↔ mm	kg/piece	⊞	Stock	Unit
HD	COMEGACL 170*150	170	182	-	-	0.460	12	✓	piece
HD	COMEGACL 170*200	170	232	-	-	0.540	12	✓	piece
HD	COMEGACL 170*300	170	332	-	-	0.700	12	✓	piece
HD	COMEGACL 170*400	170	432	-	-	0.860	6	✓	piece

To use with :

- COMEGACL 170\*150 : VF(L) 35\*100, VF(L) 35\*150, VF(L) 60\*100, VF(L) 60\*150
- COMEGACL 170\*200 : VF(L) 35\*150, VF(L) 60\*150, VF(L) 60\*200
- COMEGACL 170\*300 : VF(L) 35\*200, VF(L) 35\*250, VF(L) 60\*200, VF(L) 60\*300
- COMEGACL 170\*400 : VF(L) 35\*350, VF(L) 60\*300, VF(L) 60\*400

Max. load (in daN) : uniformly distributed over complete width of cantilever brackets.

**COMEGA 170**

**Open suspension bracket**

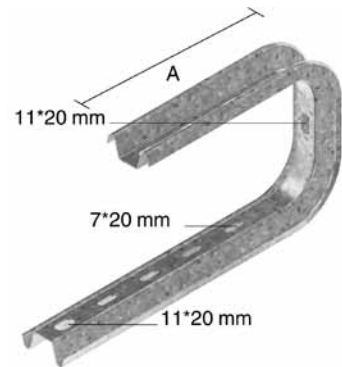

Useful for direct mounting to the ceiling or with threaded rod TIM 8 or TIM 10.

On Demand	Powder coating
Standard finish	Pre-galvanised
Optional finish 1	Hot-dip galvanised

	Max. load (in daN)	A
COMEGA 170*150	60	147
COMEGA 170*200	60	172
COMEGA 170*300	50	222
COMEGA 170*400	40	272

HD	Reference	↑ mm	↔ mm	↔ mm	↔ mm	kg/piece	⊞	Stock	Unit
HD	COMEGA 170*150	170	182	-	-	0.460	12	✓	piece
HD	COMEGA 170*200	170	232	-	-	0.540	12	✓	piece
HD	COMEGA 170*300	170	332	-	-	0.700	12	✓	piece
HD	COMEGA 170*400	170	432	-	-	0.860	12	✓	piece

Max. load (in daN): uniformly distributed over complete width of cantilever brackets.



## COMEGA 290

### Open suspension bracket

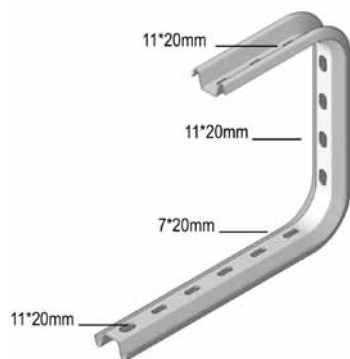

Useful for direct mounting to the ceiling or with threaded rod TIM 8 or TIM 10.

On Demand	Powder coating / Duplex System
Standard finish	Pre-galvanised

	Max. load (in daN)
COMEGA 290*100	70
COMEGA 290*150	60
COMEGA 290*200	60
COMEGA 290*250	50
COMEGA 290*300	50
COMEGA 290*400	40

HD	Reference	↑ mm	↔ mm	↔ mm	↔ mm	kg/piece	⊞	Stock	Unit
-	COMEGA 290*100	290	145	-	-	0.520	12	✓	piece
-	COMEGA 290*150	290	195	-	-	0.560	12	✓	piece
-	COMEGA 290*200	290	245	-	-	0.620	12	✓	piece
-	COMEGA 290*250	290	295	-	-	0.760	6	✓	piece
-	COMEGA 290*300	290	345	-	-	0.820	6	✓	piece
-	COMEGA 290*400	290	445	-	-	0.930	6	✓	piece

Fixation of the cable tray by VM 6\*10.

Use the VOMEGA to avoid compression of the profile.

Max. load (in daN): uniformly distributed over complete width of cantilever brackets.

## CCLTI

### Bracket KBSTI for wall and ceiling

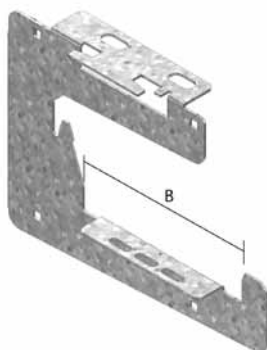

Ideal for installations in low ceiling.  
Also applicable for KBSI, KBS, KGI, KG.

On Demand	Powder coating / Duplex System
Standard finish	Pre-galvanised

	Max. load (daN) (wall)	Max. load (daN) (ceiling)	B
CCLTI 150	107	63	103
CCLTI 200	80	47	153
CCLTI 250	150	110	203
CCLTI 300	133	83	253
CCLTI 400	100	62	353

HD	Reference	↑ mm	↔ mm	↔ mm	↔ mm	kg/piece	⊞	Stock	Unit
-	CCLTI 150	179	200	-	-	0.430	6	✓	piece
-	CCLTI 200	181	250	-	-	0.510	6	✓	piece
-	CCLTI 250	189	300	-	-	0.770	6	✓	piece
-	CCLTI 300	193	350	-	-	1.090	6	✓	piece
-	CCLTI 400	190	450	-	-	1.350	6	✓	piece

More technical specifications for this product can be found at the end of this chapter.

Multiple brackets can be mounted one below another.

**LOMEGACL 150**

**QUICK & CLICK**

**Snap-in wall bracket for VF/VFL**

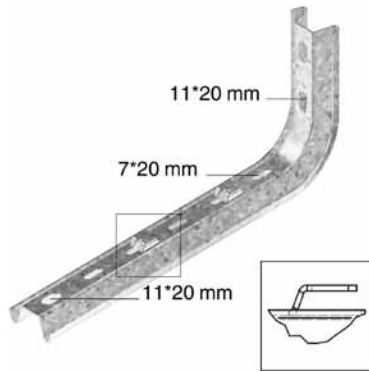

On Demand	Powder coating
Standard finish	Pre-galvanised
Optional finish 1	Hot-dip galvanised

	Max. load (in daN)
LOMEGACL 150*150	100
LOMEGACL 150*200	90
LOMEGACL 150*300	70
LOMEGACL 150*400	50

HD	Reference	↑ mm	↔ mm	↔ mm	↔ mm	kg/piece	⊞	Stock	Unit
HD	LOMEGACL 150*150	145	195	-	-	0.330	12	✓	piece
HD	LOMEGACL 150*200	145	245	-	-	0.380	12	✓	piece
HD	LOMEGACL 150*300	145	345	-	-	0.480	12	✓	piece
HD	LOMEGACL 150*400	145	445	-	-	0.590	6	✓	piece

To use with :

LOMEGACL 150\*150 : VF(L) 35\*100, VF(L) 35\*150, VF(L) 60\*100, VF(L) 60\*150  
 LOMEGACL 150\*200 : VF(L) 35\*150, VF(L) 35\*200, VF(L) 60\*150, VF(L) 60\*200  
 LOMEGACL 150\*300 : VF(L) 35\*200, VF(L) 35\*250, VF(L) 60\*200, VF(L) 60\*300  
 LOMEGACL 150\*400 : VF(L) 35\*350, VF(L) 60\*300, VF(L) 60\*400

Max. load (in daN): uniformly distributed over complete width of cantilever brackets.

**LOMEGA 150**

**Bracket/ceiling profile**

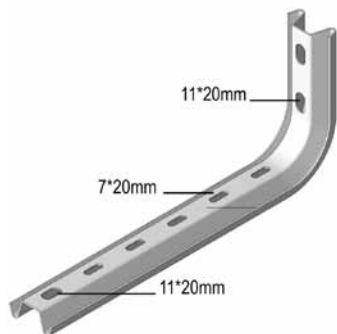

On Demand	Powder coating / Duplex System
Standard finish	Pre-galvanised

	Max. load (in daN)
LOMEGA 150*100	110
LOMEGA 150*150	100
LOMEGA 150*200	90
LOMEGA 150*250	80
LOMEGA 150*300	70
LOMEGA 150*400	50
LOMEGA 150*500	40
LOMEGA 150*600	30

HD	Reference	↑ mm	↔ mm	↔ mm	↔ mm	kg/piece	⊞	Stock	Unit
-	LOMEGA 150*100	145	145	-	-	0.300	12	✓	piece
-	LOMEGA 150*150	145	195	-	-	0.320	12	✓	piece
-	LOMEGA 150*200	145	245	-	-	0.340	12	✓	piece
-	LOMEGA 150*250	145	295	-	-	0.450	12	✓	piece
-	LOMEGA 150*300	145	345	-	-	0.490	12	✓	piece
-	LOMEGA 150*400	145	445	-	-	0.540	6	✓	piece
-	LOMEGA 150*500	145	545	-	-	0.710	6	✓	piece
-	LOMEGA 150*600	145	645	-	-	0.770	6	✓	piece

Use the VOMEGA to avoid compression of the profile.

Max. load (in daN): uniformly distributed over complete width of cantilever brackets.

## VOMEGA

### Jointing piece

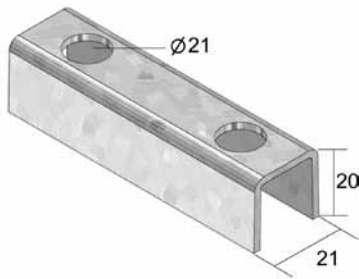

On Demand

Powder coating / Duplex System

Standard finish

Pre-galvanised

HD	Reference	↑ mm	↔ mm	↔ mm	↔ mm	kg/piece	📦	Stock	Unit
-	<b>VOMEGA</b>	-	-	-	-	0.060	48	✓	piece

For wall mounting 1 piece, for double mounting 2 pieces, back to back.

## MBZ

### Wall support

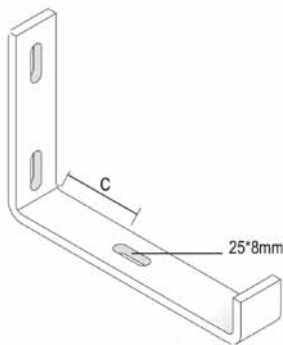

On Demand

Powder coating / Duplex System

Max. load

40 daN

Standard finish

Hot-dip galvanised

	C
MBZ 075	30
MBZ 100	47,50
MBZ 150	65,50
MBZ 200	97,50

HD	Reference	↑ mm	↔ mm	↔ mm	↔ mm	kg/piece	📦	Stock	Unit
-	<b>MBZ 075</b>	120	104	-	-	0.310	6	✓	piece
-	<b>MBZ 100</b>	120	125	-	-	0.350	6	✓	piece
-	<b>MBZ 150</b>	120	175	-	-	0.470	6	✓	piece
-	<b>MBZ 200</b>	120	233	-	-	0.660	6	✓	piece

**WS**

**Wall support**

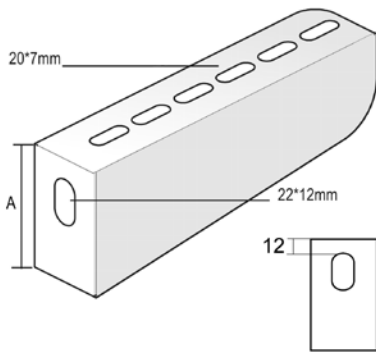

For direct fixation on the wall

On Demand	Powder coating / Duplex System
Standard finish	Pre-galvanised

	Max. load (in daN)	A
WS 100	70	53
WS 150	60	58.5
WS 200	60	64
WS 250	60	69
WS 300	50	75
WS 400	50	86
WS 500	40	96
WS 600	30	107

HD	Reference	↑ mm	↔ mm	↔ mm	↔ mm	kg/piece	⊞	Stock	Unit
-	WS 100	53	117	-	-	0.130	48	✓	piece
-	WS 150	58,5	167	-	-	0.190	48	✓	piece
-	WS 200	64	217	-	-	0.230	48	✓	piece
-	WS 250	69	267	-	-	0.300	24	✓	piece
-	WS 300	75	317	-	-	0.350	48	✓	piece
-	WS 400	86	417	-	-	0.440	24	✓	piece
-	WS 500	96	517	-	-	0.640	24	✓	piece
-	WS 600	107	617	-	-	0.740	12	✓	piece

Max. load (in daN): uniformly distributed over complete width of cantilever brackets.

**KCL**

**Bracket clips for HSLECL**

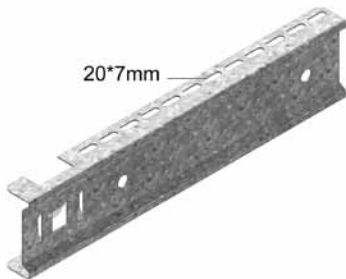

For fixation on the ceiling profile, no fixation elements required. For fixation on the ceiling profiles HSLECL and assembly profile MPCL + KPCL.

Standard finish	Pre-galvanised
-----------------	----------------

	Max. load (in daN)
KCL 100	110
KCL 150	100
KCL 200	100
KCL 250	90
KCL 300	90
KCL 400	70
KCL 500	60
KCL 600	50

HD	Reference	↑ mm	↔ mm	↔ mm	↔ mm	kg/piece	⊞	Stock	Unit
-	KCL 100	80	180	-	-	0.220	48	✓	piece
-	KCL 150	80	230	-	-	0.300	48	✓	piece
-	KCL 200	80	280	-	-	0.350	48	✓	piece
-	KCL 250	80	330	-	-	0.440	24	✓	piece
-	KCL 300	80	380	-	-	0.470	24	✓	piece
-	KCL 400	80	480	-	-	0.750	24	✓	piece
-	KCL 500	80	580	-	-	0.950	12	✓	piece
-	KCL 600	80	680	-	-	1.130	12	✓	piece

Adapter CLHS for a symmetrical fixation.

Max. load (in daN): uniformly distributed over complete width of cantilever brackets.

## WKS

## Screwed bracket

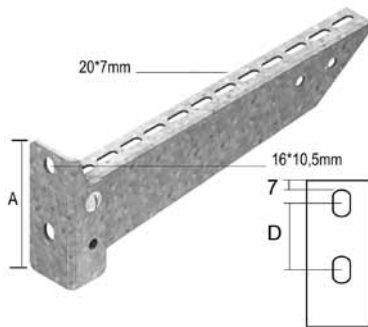

For direct fixation on the wall and also for fixation on the ceiling profiles

On Demand	Powder coating / Duplex System
Standard finish	Pre-galvanised
Optional finish 1	Hot-dip galvanised

	Max. load (in daN)	A	D
WKS 100	110	99	40
WKS 150	110	99	40
WKS 200	120	99	40
WKS 250	120	99	40
WKS 300	130	119	60
WKS 400	130	119	60
WKS 500	140	139	80
WKS 600	150	139	80

HD	Reference	↑ mm	↔ mm	↔ mm	↔ mm	kg/piece	📦	Stock	Unit
HD	<b>WKS 100</b>	99	117	-	-	0.240	24	✓	piece
HD	<b>WKS 150</b>	99	167	-	-	0.330	24	✓	piece
HD	<b>WKS 200</b>	99	217	-	-	0.380	24	✓	piece
HD	<b>WKS 250</b>	99	267	-	-	0.430	12	✓	piece
HD	<b>WKS 300</b>	119	317	-	-	0.630	12	✓	piece
HD	<b>WKS 400</b>	119	417	-	-	0.760	12	✓	piece
HD	<b>WKS 500</b>	139	517	-	-	1.000	6	✓	piece
HD	<b>WKS 600</b>	139	617	-	-	1.230	6	✓	piece

For fixation on ceiling profiles, order the necessary fixation elements separately : two sliding nuts GM 41 M 10 and

- bolt B 10\*20 per bracket for ceiling profile HSLECL/HSLDCL.

- bolt B 10\*30 per bracket for ceiling profile HSME/HSMD.

Max. load (in daN): uniformly distributed over complete width of cantilever brackets.

**WKSS**

**Adjustable bracket**

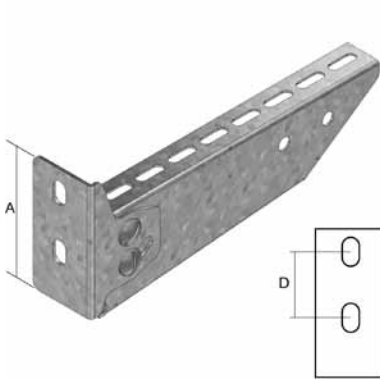

For direct fixation on the wall and on the ceiling profiles. Adjustable angle from -20° to +40°.

On Demand	Powder coating / Duplex System
Standard finish	Pre-galvanised
Optional finish 1	Hot-dip galvanised

	Max. load (in daN)	A	D
WKSS 100	110	90	40
WKSS 150	110	90	40
WKSS 200	120	90	40
WKSS 250	120	90	40
WKSS 300	100	110	60
WKSS 400	75	110	60
WKSS 500	60	130	80
WKSS 600	50	130	80

HD	Reference	↑ mm	↔ mm	↔ mm	↔ mm	kg/piece	📦	Stock	Unit
HD	<b>WKSS 100</b>	90	117	-	-	0.330	24	✓	piece
HD	<b>WKSS 150</b>	90	167	-	-	0.270	24	✓	piece
HD	<b>WKSS 200</b>	90	217	-	-	0.320	24	✓	piece
HD	<b>WKSS 250</b>	90	267	-	-	0.380	12	✓	piece
HD	<b>WKSS 300</b>	110	317	-	-	0.650	12	✓	piece
HD	<b>WKSS 400</b>	110	417	-	-	0.830	12	✓	piece
HD	<b>WKSS 500</b>	130	517	-	-	1.080	6	✓	piece
HD	<b>WKSS 600</b>	130	617	-	-	1.260	6	✓	piece

**WK**

**Joined bracket**

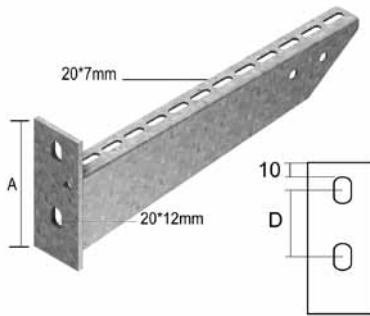

For direct fixation on the wall and also for fixation on the ceiling profile

On Demand	Powder coating / Duplex System
Thickness head plate	5 mm
Standard finish	Hot-dip galvanised

	Max. load (in daN)	A	D
WK 100	120	106.5	46.5
WK 150	230	112	52
WK 200	340	116	56
WK 250	450	120.5	60.5
WK 300	320	125	65
WK 400	430	134	74
WK 500	390	142.5	82.5
WK 600	350	150	90
WK 800	280	150	90
WK 1000	200	150	90

HD	Reference	↑ mm	↔ mm	↔ mm	↔ mm	kg/piece	⊞	Stock	Unit
-	WK 100	106,5	117	-	-	0.300	24	✓	piece
-	WK 150	112	167	-	-	0.360	24	✓	piece
-	WK 200	116	217	-	-	0.430	24	✓	piece
-	WK 250	120,5	267	-	-	0.530	12	✓	piece
-	WK 300	125	317	-	-	0.730	12	✓	piece
-	WK 400	134	417	-	-	0.880	12	✓	piece
-	WK 500	142,5	517	-	-	1.300	6	✓	piece
-	WK 600	150	617	-	-	1.600	6	✓	piece
-	WK 800	150	817	-	-	1.900	1	✓	piece
-	WK 1000	150	1017	-	-	2.400	1	✓	piece

For fixation on ceiling profiles, order the necessary fixation elements separately : two sliding nuts GM 41 M 10 and

- tapbolt B 10\*20 per bracket for ceiling profile HSLECL/HSLDCL.
- tapbolt B 10\*30 per bracket for ceiling profile HSME/HSMD.

Max. load (in daN): uniformly distributed over complete width of cantilever brackets.

**WKM**

**Heavy joined bracket**

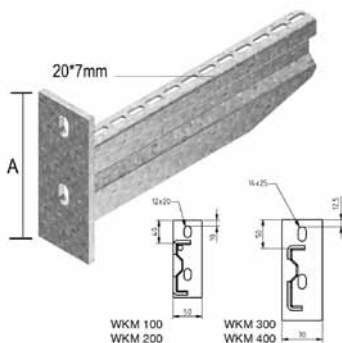

For direct fixation on the wall and also for fixation on the ceiling profile

On Demand	Powder coating / Duplex System
Standard finish	Hot-dip galvanised

	Max. load (in daN)
WKM 100	600
WKM 200	620
WKM 300	620
WKM 400	610

HD	Reference	↑ mm	↔ mm	↔ mm	↔ mm	kg/piece	⊞	Stock	Unit
-	WKM 100	125	125	-	-	0.450	24	✓	piece
-	WKM 200	134	225	-	-	0.650	24	✓	piece
-	WKM 300	175	325	-	-	1.530	12	✓	piece
-	WKM 400	175	425	-	-	1.830	12	✓	piece

Max. load (in daN): uniformly distributed over complete width of cantilever brackets.

**WKZ**

**Extra heavy joined bracket**

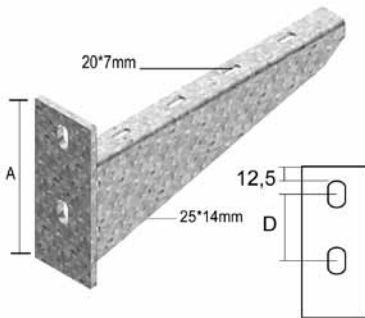

Only for direct fixation on the wall

On Demand	Powder coating / Duplex System
Thickness head plate	8 mm
Standard finish	Hot-dip galvanised

	Max. load (in daN)	A	D
WKZ 300	750	175	82.5
WKZ 400	740	200	107.5
WKZ 500	720	230	137.5
WKZ 600	710	260	167.5

HD	Reference	↑ mm	↔ mm	↔ mm	↔ mm	kg/piece	⊞	Stock	Unit
-	WKZ 300	175	325	-	-	1.650	1	✓	piece
-	WKZ 400	200	425	-	-	2.200	1	✓	piece
-	WKZ 500	230	525	-	-	2.970	1	✓	piece
-	WKZ 600	260	625	-	-	3.700	1	✓	piece

Max. load (in daN): uniformly distributed over complete width of cantilever brackets.

**HKI**

**Joined clamping bracket**

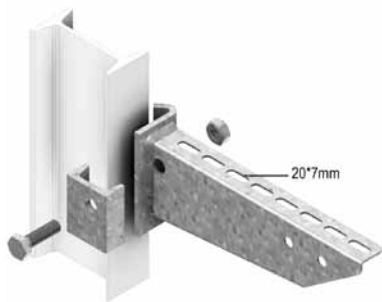

For fixation on the ceiling profile HSIZ and IPN 80 SL profile

On Demand	Powder coating / Duplex System
Standard finish	Hot-dip galvanised

	Max. Load (in daN)
HKI 100	300
HKI 150	310
HKI 200	330
HKI 250	340
HKI 300	360
HKI 400	370
HKI 500	380
HKI 600	410
HKI 800	370
HKI 1000	330

HD	Reference	↑ mm	↔ mm	↔ mm	↔ mm	kg/piece	⊞	Stock	Unit
-	HKI 100	90	117	-	-	0.300	24	✓	piece
-	HKI 150	90	167	-	-	0.370	24	✓	piece
-	HKI 200	90	217	-	-	0.500	24	✓	piece
-	HKI 250	100	267	-	-	0.460	12	✓	piece
-	HKI 300	100	317	-	-	0.690	12	✓	piece
-	HKI 400	117	417	-	-	0.850	12	✓	piece
-	HKI 500	117	517	-	-	1.350	6	✓	piece
-	HKI 600	117	617	-	-	1.550	6	✓	piece
-	HKI 800	117	817	-	-	1.800	1	✓	piece
-	HKI 1000	117	1017	-	-	2.300	1	✓	piece

Welded headplate.

Clamp plate, bolt B 10\*40 and nut M 10 inclusive.

Max. load (in daN): uniformly distributed over complete width of cantilever brackets.



## HKIZ

## Extra heavy joined clamping bracket

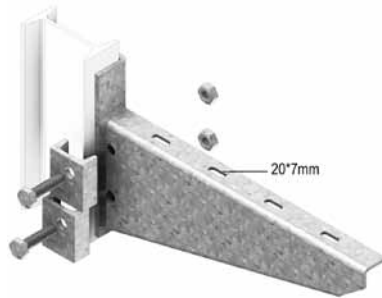

Only for fixation on IPN 80 SL profile

On Demand Powder coating / Duplex System

Thickness head plate 5 mm

Standard finish Hot-dip galvanised

	Max. load (in daN)
HKIZ 300	900
HKIZ 400	910
HKIZ 500	920
HKIZ 600	930

HD	Reference	↑ mm	↔ mm	↔ mm	↔ mm	kg/piece	📦	Stock	Unit
-	<b>HKIZ 300</b>	175	325	-	-	1.300	1	✓	piece
-	<b>HKIZ 400</b>	200	425	-	-	1.700	1	✓	piece
-	<b>HKIZ 500</b>	230	525	-	-	2.250	1	✓	piece
-	<b>HKIZ 600</b>	260	625	-	-	3.050	1	✓	piece

Headplate is welded.

2x Clamp plate, 2x bolt B 10\*40 and 2x nut M 10 inclusive.

Max. load (in daN): uniformly distributed over complete width of cantilever brackets.

## KPCL

## Headplate clips

QUICK & CLICK

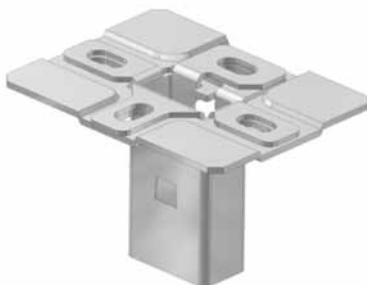

Headplate clips for ceiling profile

Max. load 300 daN

Standard finish Pre-galvanised

HD	Reference	↑ mm	↔ mm	↔ mm	↔ mm	kg/piece	📦	Stock	Unit
-	<b>KPCL 41*21</b>	84	130	-	-	0.530	10	✓	piece

- revolutionary and saves costs
- tested according to CEI/IEC 61537.
- the end plate should always be fixed with the supplied supporting plate.

**MPCL**

**QUICK & CLICK**

**Assembly profile clips**

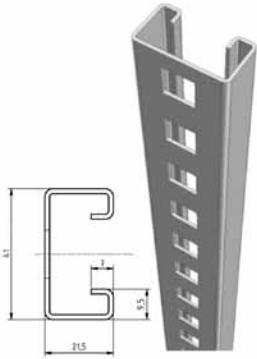

On Demand Powder coating / Duplex System  
 Standard finish Pre-galvanised

HD	Reference	↑ mm	↔ mm	↔ mm	↔ mm	kg/piece	⊞	Stock	Unit
-	MPCL 41*21*1.50*200	41	21	1.500	210	0.240	10	✓	piece
-	MPCL 41*21*1.50*300	41	21	1.500	300	0.340	10	✓	piece
-	MPCL 41*21*1.50*400	41	21	1.500	420	0.480	10	✓	piece
-	MPCL 41*21*1.50*500	41	21	1.500	510	0.580	10	✓	piece
-	MPCL 41*21*1.50*600	41	21	1.500	600	0.680	10	✓	piece
-	MPCL 41*21*1.50*800	41	21	1.500	810	0.920	10	✓	piece
-	MPCL 41*21*1.50*3000	41	21	1.500	3000	1.150	3	✓	m

- is preassembled with consoles, the resulting assembly clips into the KPCL
- clips into the KPCL as far as the ceiling, after which the system locks itself into place
- ideal in combination with the KCL console
- protection cap in yellow PVC : DOPHSLECL.

**HSLECL**

**QUICK & CLICK**

**Single Ceiling profile clips**

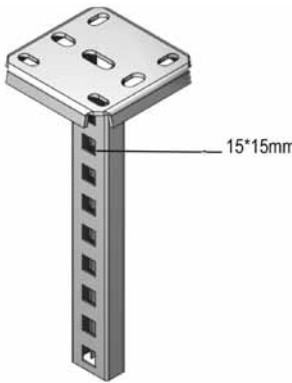

Ceiling profile : MP 41\*21  
 Welded headplate: 120 x 120 mm

On Demand Powder coating / Duplex System  
 Max. load 300 daN  
 Thickness head plate 4 mm  
 Standard finish Hot-dip galvanised

HD	Reference	↑ mm	↔ mm	↔ mm	↔ mm	kg/piece	⊞	Stock	Unit
-	HSLECL 200	-	-	-	210	0.740	25	✓	piece
-	HSLECL 300	-	-	-	300	0.850	1	✓	piece
-	HSLECL 400	-	-	-	420	1.010	1	✓	piece
-	HSLECL 500	-	-	-	510	1.130	1	✓	piece
-	HSLECL 600	-	-	-	600	1.230	1	✓	piece
-	HSLECL 800	-	-	-	810	1.450	1	✓	piece
-	HSLECL 1000	-	-	-	1020	1.750	1	✓	piece
-	HSLECL 1200	-	-	-	1200	1.950	1	✓	piece

More technical specifications for this product can be found at the end of this chapter.

For one and double sided fixation of the bracket KCL and for one sided fixation of the other brackets WKS and WK using sliding nut GM 41 M 10 and hexagonal bolt B 10\*20.  
 Protection cap in yellow PVC : DOPHSLECL.

**CLHS**

**QUICK & CLICK**

**Adapter clips for HSLECL**



Standard finish

Pre-galvanised

HD	Reference	↑ mm	↔ mm	↔ mm	↔ mm	kg/piece	⊞	Stock	Unit
-	<b>CLHS</b>	-	-	-	-	0.120	24	✓	piece

**HSLDCL**

**Double Ceiling profile clips**



Ceiling profile : MP 41\*21  
Welded headplate: 120 x 120 mm

On Demand

Powder coating / Duplex System

Max. load

500 daN

Thickness head plate

4 mm

Standard finish

Hot-dip galvanised

HD	Reference	↑ mm	↔ mm	↔ mm	↔ mm	kg/piece	⊞	Stock	Unit
-	<b>HSLDCL 200</b>	-	-	-	210	1.000	20	✓	piece
-	<b>HSLDCL 300</b>	-	-	-	300	1.230	1	✓	piece
-	<b>HSLDCL 400</b>	-	-	-	420	1.480	1	✓	piece
-	<b>HSLDCL 500</b>	-	-	-	510	1.700	1	✓	piece
-	<b>HSLDCL 600</b>	-	-	-	600	1.900	1	✓	piece
-	<b>HSLDCL 800</b>	-	-	-	810	2.250	1	✓	piece
-	<b>HSLDCL 1000</b>	-	-	-	1020	2.900	1	✓	piece
-	<b>HSLDCL 1200</b>	-	-	-	1200	3.340	1	✓	piece

More technical specifications for this product can be found at the end of this chapter.

For one and double sided fixation of the bracket WKS and WK.

Use sliding nut GM 41 M 10 and hexagonal bolt B 10\*20.

Protection cap in yellow PVC : DOP 41\*41.

**HSME**

**Single ceiling profile**

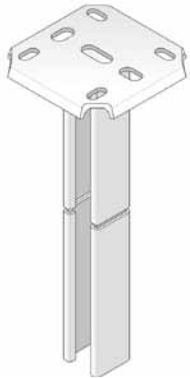

Ceiling profile : MP 41\*41  
Welded headplate: 120 x 120 mm

On Demand	Powder coating / Duplex System
Max. load	800 daN
Thickness head plate	4 mm
Standard finish	Hot-dip galvanised

HD	Reference	↑ mm	↔ mm	↔ mm	↔ mm	kg/piece	⊞	Stock	Unit
-	<b>HSME 200</b>	-	-	-	200	1.030	20	✓	piece
-	<b>HSME 300</b>	-	-	-	300	1.330	1	✓	piece
-	<b>HSME 400</b>	-	-	-	400	1.600	1	✓	piece
-	<b>HSME 500</b>	-	-	-	500	1.900	1	✓	piece
-	<b>HSME 600</b>	-	-	-	600	2.150	1	✓	piece
-	<b>HSME 800</b>	-	-	-	800	2.700	1	✓	piece
-	<b>HSME 1000</b>	-	-	-	1000	3.250	1	✓	piece
-	<b>HSME 1200</b>	-	-	-	1200	3.800	1	✓	piece
-	<b>HSME 1500</b>	-	-	-	1500	4.620	1	✓	piece

More technical specifications for this product can be found at the end of this chapter.

For one sided fixation of the brackets.  
Use sliding nut GM 41 M 10 and hexagonal bolt B 10\*30.  
Protection cap in yellow PVC : DOP 41\*41.

**HSMU**

**Ceiling profile medium heavy**



Max. load	1000 daN
Standard finish	Hot-dip galvanised

HD	Reference	↑ mm	↔ mm	↔ mm	↔ mm	kg/piece	⊞	Stock	Unit
-	<b>HSMU 50*200</b>	-	-	-	200	0.940	1	✓	piece
-	<b>HSMU 50*300</b>	-	-	-	300	1.160	1	✓	piece
-	<b>HSMU 50*400</b>	-	-	-	400	1.380	1	✓	piece
-	<b>HSMU 50*500</b>	-	-	-	500	1.610	1	✓	piece
-	<b>HSMU 50*600</b>	-	-	-	600	1.830	1	✓	piece
-	<b>HSMU 50*800</b>	-	-	-	800	2.270	1	✓	piece
-	<b>HSMU 50*1000</b>	-	-	-	1000	2.710	1	✓	piece
-	<b>HSMU 50*1200</b>	-	-	-	1200	3.150	1	✓	piece
-	<b>HSMU 50*1500</b>	-	-	-	1500	3.820	1	✓	piece

More technical specifications for this product can be found at the end of this chapter.

## TSU 50

### Spacer HSMU 50

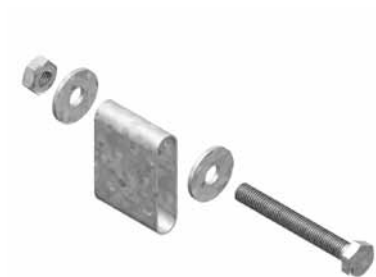

Standard finish

Hot-dip galvanised

HD	Reference	↑ mm	↔ mm	↔ mm	↔ mm	kg/piece	⊞	Stock	Unit
-	<b>TSU 50</b>	-	-	-	-	0.140	6	✓	piece

Bolt B 10\*80, CRO 10 and nuts M 10 inclusive.

## HSMD

### Double ceiling profile

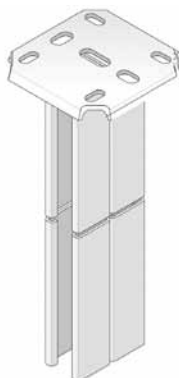

Ceiling profile : MP 41\*41  
Welded headplate: 120 x 120 mm

On Demand

Powder coating / Duplex System

Max. load

1500 daN

Thickness head plate

4 mm

Standard finish

Hot-dip galvanised

HD	Reference	↑ mm	↔ mm	↔ mm	↔ mm	kg/piece	⊞	Stock	Unit
-	<b>HSMD 200</b>	-	-	-	200	1.600	15	✓	piece
-	<b>HSMD 300</b>	-	-	-	300	2.150	1	✓	piece
-	<b>HSMD 400</b>	-	-	-	400	2.650	1	✓	piece
-	<b>HSMD 500</b>	-	-	-	500	3.300	1	✓	piece
-	<b>HSMD 600</b>	-	-	-	600	3.900	1	✓	piece
-	<b>HSMD 800</b>	-	-	-	800	4.900	1	✓	piece
-	<b>HSMD 1000</b>	-	-	-	1000	6.000	1	✓	piece
-	<b>HSMD 1200</b>	-	-	-	1200	7.200	1	✓	piece
-	<b>HSMD 1500</b>	-	-	-	1500	9.000	1	✓	piece

For one and double sided fixation of the brackets.  
Use sliding nut GM 41 M 10 and hexagonal bolt B 10\*30.  
Protection cap in yellow PVC : DOPHSMD.

**HSIZ**

**Heavy ceiling profile**

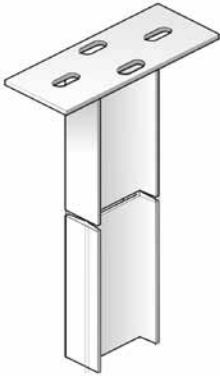

Ceiling profile: IPN 80  
Welded headplate: 80 x 200 mm

On Demand	Powder coating / Duplex System
Max. load	2000 daN
Thickness head plate	5 mm
Standard finish	Hot-dip galvanised

HD	Reference	↑ mm	↔ mm	↔ mm	↔ mm	kg/piece	⊞	Stock	Unit
-	HSIZ 200	-	-	-	200	1.800	1	✓	piece
-	HSIZ 400	-	-	-	400	3.050	1	✓	piece
-	HSIZ 500	-	-	-	500	3.600	1	✓	piece
-	HSIZ 600	-	-	-	600	4.200	1	✓	piece
-	HSIZ 800	-	-	-	800	5.500	1	✓	piece
-	HSIZ 1000	-	-	-	1000	6.700	1	✓	piece
-	HSIZ 1200	-	-	-	1200	8.000	1	✓	piece
-	HSIZ 1500	-	-	-	1500	9.900	1	✓	piece
-	HSIZ 1800	-	-	-	1800	12.000	1	✓	piece
-	HSIZ 2000	-	-	-	2000	13.300	1	✓	piece

More technical specifications for this product can be found at the end of this chapter.

For double sided fixation of clamp brackets.

Application : as ceiling or floor support.

Protection cap in yellow PVC : PR 80.

5

**DOP 41\*41**

**Protection cap for pendant 41x41**

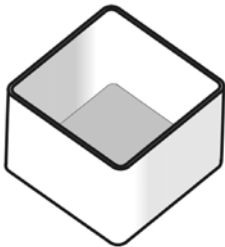

Color	yellow
Standard finish	Polyvinyl chloride

HD	Reference	↑ mm	↔ mm	↔ mm	↔ mm	kg/piece	⊞	Stock	Unit
-	DOP 41*41	26	41	2.000	41	0.010	50	✓	piece

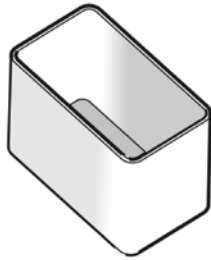
**DOPHSLECL****Protection cap for HSLECL**

Color yellow

Standard finish Polyvinyl chloride

HD	Reference	↑ mm	↔ mm	↔ mm	↔ mm	kg/piece	📦	Stock	Unit
-	<b>DOPHSLECL</b>	-	-	-	-	0.010	50	✓	piece

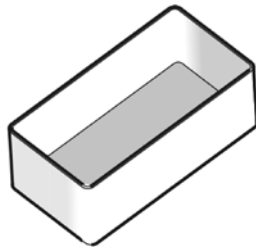
**DOPHSMD****Protection cap for HSMD**

Color yellow

Standard finish Polyvinyl chloride

HD	Reference	↑ mm	↔ mm	↔ mm	↔ mm	kg/piece	📦	Stock	Unit
-	<b>DOPHSMD</b>	-	-	-	-	0.020	50	✓	piece

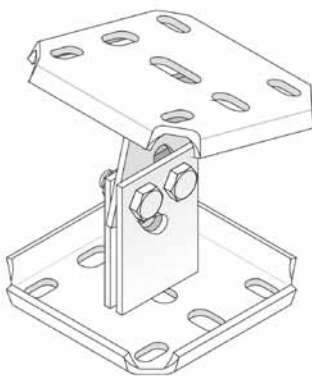
**SKP****Adjustable head plate**

Standard finish Hot-dip galvanised

HD	Reference	↑ mm	↔ mm	↔ mm	↔ mm	kg/piece	📦	Stock	Unit
-	<b>SKP</b>	-	120	-	120	1.300	12	✓	piece

More technical specifications for this product can be found at the end of this chapter.

Headplate 120 x 120 mm with fixation holes.

Ideal for fixation at sloping ceilings with 4 bolts B 10\*20 and 4 screws M 10, max. angle of 60°.

**IPN 80 SL**

**Perforated I-profile**

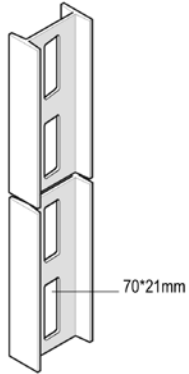

On Demand Powder coating / Duplex System  
 Standard finish Hot-dip galvanised

HD	Reference	↑ mm	↔ mm	⊥ mm	↔ mm	kg/m	⊞	Stock	Unit
-	<b>IPN 80 SL</b>	80	42	-	6000	5.750	6	✓	m

Resistance moment :  $W_x = 19.50 \text{ cm}^3$ .  
 Protection cap in yellow PVC : PR 80.

**PR 80**

**Protection cap for IPN 80 SL**

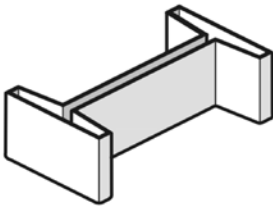

Color yellow  
 Standard finish Polyvinyl chloride

HD	Reference	↑ mm	↔ mm	⊥ mm	↔ mm	kg/piece	⊞	Stock	Unit
-	<b>PR 80</b>	26	80	-	-	0.020	12	✓	piece

**IPL 06**

**Headplate for IPN 80 SL**



On Demand Powder coating / Duplex System  
 Thickness head plate 5 mm  
 Standard finish Hot-dip galvanised

HD	Reference	↑ mm	↔ mm	⊥ mm	↔ mm	kg/piece	⊞	Stock	Unit
-	<b>IPL 06</b>	185	80	5.000	-	1.430	6	✓	piece

More technical specifications for this product can be found at the end of this chapter.  
 To be fixed on IPN 80 SL with 2 bolts B 12\*40 and nuts M 12.



## IPL 10

### Headplate for IPN 80 SL

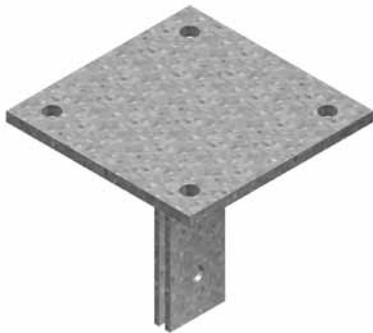

On Demand	Powder coating / Duplex System
Thickness head plate	10 mm
Standard finish	Hot-dip galvanised

HD	Reference	↑ mm	↔ mm	↔ mm	↔ mm	kg/piece	📦	Stock	Unit
-	<b>IPL 10</b>	190	200	10.000	-	3.910	1	✓	piece

More technical specifications for this product can be found at the end of this chapter.  
To be fixed on IPN 80 SL with 2 bolts B 12\*40 and nuts M 12.

## SKIPN

### Hinged headplate for IPN 80 SL

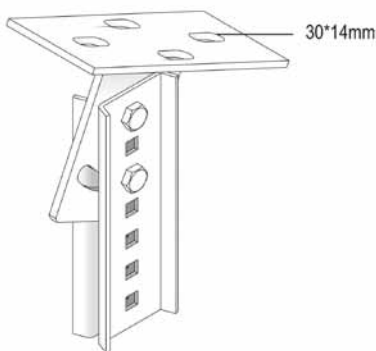

To be mounted on IPN 80 SL profile, max. angle of 35°.

On Demand	Powder coating / Duplex System
Standard finish	Hot-dip galvanised

HD	Reference	↑ mm	↔ mm	↔ mm	↔ mm	kg/piece	📦	Stock	Unit
-	<b>SKIPN</b>	-	-	3.000	191	1.670	6	✓	piece

More technical specifications for this product can be found at the end of this chapter.  
2x bolt HDB 10\*30, 2x nut HDM 10 and 2x HDRO 10 inclusive.

## KPIPn

### Jointing piece for IPN 80 SL

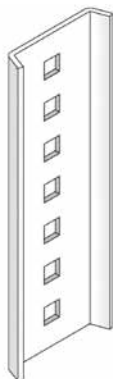

To joint straighten IPN 80 SL profiles.

On Demand	Powder coating / Duplex System
Standard finish	Hot-dip galvanised

HD	Reference	↑ mm	↔ mm	↔ mm	↔ mm	kg/piece	📦	Stock	Unit
-	<b>KPIPn</b>	67	-	3.000	191	0.370	6	✓	piece

Fixation set B 10\*30, M 10 and RO 10 to be ordered separately.

**DKIPN**

**Cross jointing plate for IPN 80 SL**

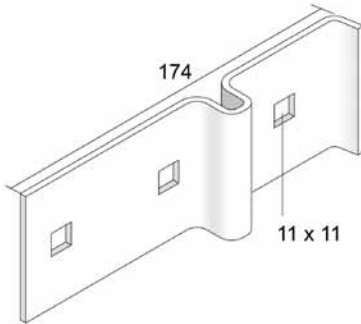

To joint squarely 2 IPN 80 SL profiles.

On Demand	Powder coating / Duplex System
Standard finish	Hot-dip galvanised

HD	Reference	↑ mm	↔ mm	↔ mm	↔ mm	kg/piece	⊞	Stock	Unit
-	<b>DKIPN</b>	60	-	3.000	-	0.270	6	✓	piece

Fixation set B 10\*30, M 10 and RO 10 to be ordered separately.

**KIPN**

**Mounting piece IPN 80 SL**

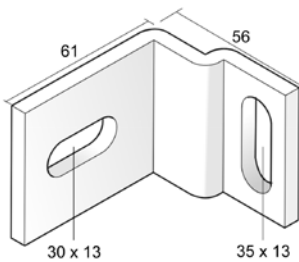

To fix the IPN 80 SL profile on the wall.

On Demand	Powder coating / Duplex System
Standard finish	Hot-dip galvanised

HD	Reference	↑ mm	↔ mm	↔ mm	↔ mm	kg/piece	⊞	Stock	Unit
-	<b>KIPN</b>	-	-	6.000	-	0.240	6	✓	piece

**WVPIP**

**Universal fixing for IPN 80 SL**

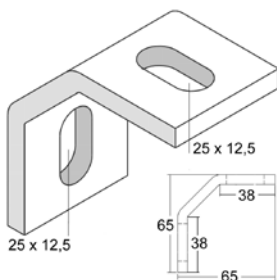

On Demand	Powder coating / Duplex System
Standard finish	Hot-dip galvanised

HD	Reference	↑ mm	↔ mm	↔ mm	↔ mm	kg/piece	⊞	Stock	Unit
-	<b>WVPIP</b>	65	65	6.500	-	0.190	50	✓	piece

## L 25

### L-profile

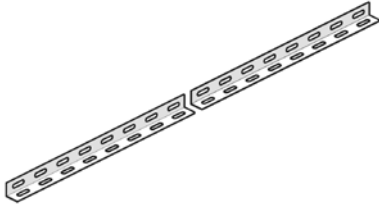

Groove holes of 25 x 7 mm with intervals of 50 mm.

On Demand	Powder coating / Duplex System
Standard finish	Pre-galvanised
Optional finish 1	Hot-dip galvanised

HD	Reference	↑ mm	↔ mm	↔ mm	↔ mm	kg/m	⊞	Stock	Unit
HD	L 25*1.25	25	25	1.250	3000	0.400	3		m
HD	L 25*2.00	25	25	2.000	3000	0.670	3		m

Groove holes of 25 x 7 mm with intervals of 50 mm.

## L 25\*50

### L-profile

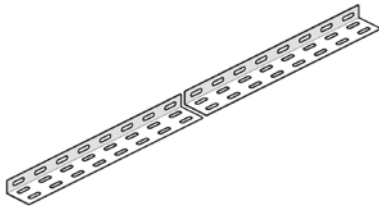

On Demand	Powder coating / Duplex System
Standard finish	Pre-galvanised
Optional finish 1	Hot-dip galvanised

HD	Reference	↑ mm	↔ mm	↔ mm	↔ mm	kg/m	⊞	Stock	Unit
HD	L 25*50*1.25	25	50	1.250	3000	0.820	3		m
HD	L 25*50*2.00	25	50	2.000	3000	1.000	3		m

Groove holes of 25 x 7 mm with intervals of 50 mm.

## L 50\*50

### L-profile

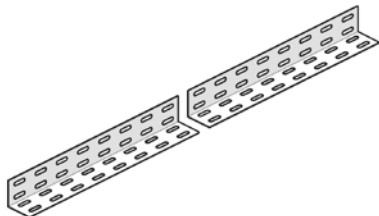

On Demand	Powder coating / Duplex System
Standard finish	Pre-galvanised
Optional finish 1	Hot-dip galvanised

HD	Reference	↑ mm	↔ mm	↔ mm	↔ mm	kg/m	⊞	Stock	Unit
HD	L 50*50*1.25	50	50	1.250	3000	0.800	3		m
HD	L 50*50*2.00	50	50	2.000	3000	1.330	3		m

Groove holes of 25 x 7 mm with intervals of 50 mm.

**Z 25**

**Z-profile**

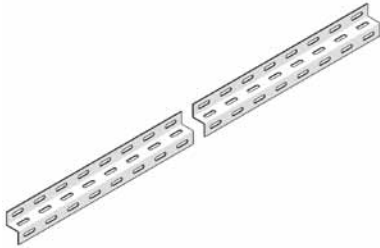

On Demand	Powder coating / Duplex System
Standard finish	Pre-galvanised
Optional finish 1	Hot-dip galvanised

HD	Reference	mm	mm	mm	mm	kg/m		Stock	Unit
HD	<b>Z 25*25*25*1.50</b>	50	25	1.500	3000	0.730	3		m

More technical specifications for this product can be found at the end of this chapter.

Profile dimensions : 25 x 25 x 25 mm.  
Groove holes of 25 x 7 mm with intervals of 50 mm.

**Z 50**

**Z-profile**

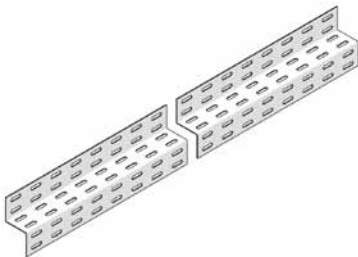

On Demand	Powder coating / Duplex System
Standard finish	Pre-galvanised
Optional finish 1	Hot-dip galvanised

HD	Reference	mm	mm	mm	mm	kg/m		Stock	Unit
HD	<b>Z 50*50*50*1.50</b>	100	50	1.500	3000	1.520	3		m

Profile dimensions : 50 x 50 x 50 mm.  
Groove holes of 25 x 7 mm with intervals of 50 mm.

**MP 41\*21\*2.50 SL**

**Assembly profile Hot dip**

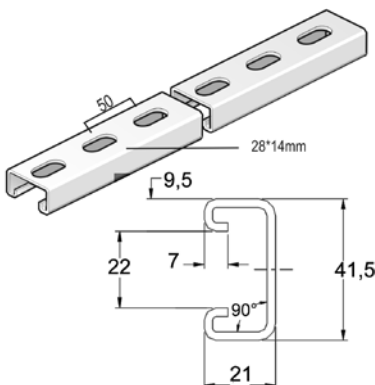

On Demand	Powder coating / Duplex System
Profile opening	22 mm
Standard finish	Hot-dip galvanised

HD	Reference	mm	mm	mm	mm	kg/m		Stock	Unit
-	<b>MP 41*21*2.50*3 SL</b>	41	21	2.500	3000	1.850	1	✓	m
-	<b>MP 41*21*2.50*6 SL</b>	41	21	2.500	6000	1.850	1	✓	m

**MPZ 41\*21\*2.50 SL**

**Assembly profile**

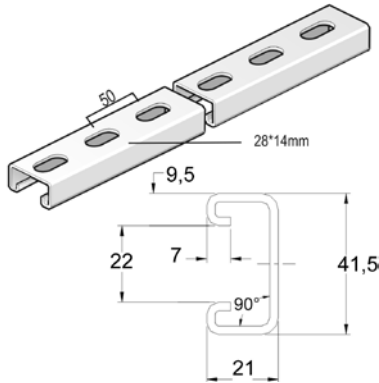

On Demand	Powder coating / Duplex System
Profile opening	22 mm
Standard finish	Pre-galvanised

HD	Reference	↑ mm	↔ mm	↔ mm	↔ mm	kg/m	⊞	Stock	Unit
-	<b>MPZ 41*21*2.50*6 SL</b>	41	21	2.500	6000	1.660	1	✓	m

**MPZ 41\*21\*1.50 SL**

**Assembly profile HD**

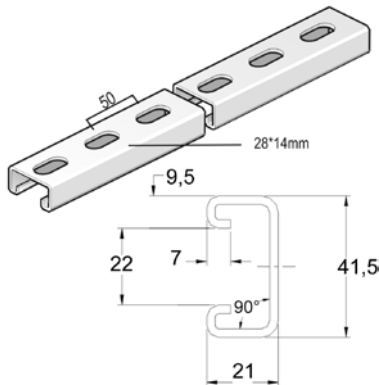

On Demand	Powder coating / Duplex System
Profile opening	22 mm
Standard finish	Pre-galvanised

HD	Reference	↑ mm	↔ mm	↔ mm	↔ mm	kg/m	⊞	Stock	Unit
-	<b>MPZ 41*21*1.50*3 SL</b>	41	21	1.500	3000	1.130	1	✓	m

**MP 41\*41\*2.50 SL**

**Assembly profile**

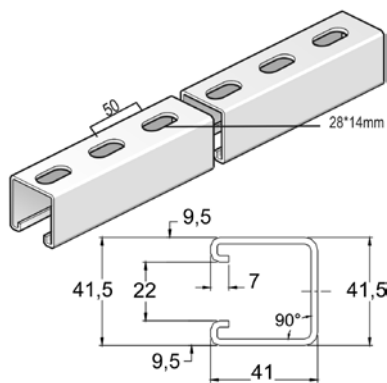

On Demand	Powder coating / Duplex System
Profile opening	22 mm
Standard finish	Hot-dip galvanised

HD	Reference	↑ mm	↔ mm	↔ mm	↔ mm	kg/m	⊞	Stock	Unit
-	<b>MP 41*41*2.50*3 SL</b>	41	41	2.500	3000	2.700	1	✓	m
-	<b>MP 41*41*2.50*6 SL</b>	41	41	2.500	6000	2.700	1	✓	m

**MPZ 41\*41\*2.50 SL**

**Assembly profile**

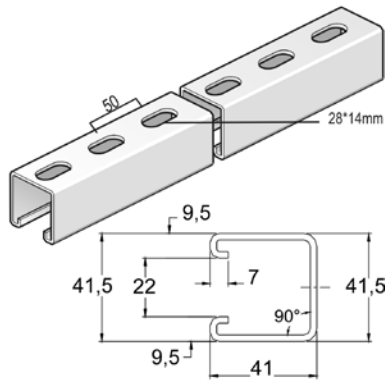

On Demand	Powder coating / Duplex System
Profile opening	22 mm
Standard finish	Pre-galvanised

HD	Reference	↑ mm	↔ mm	↔ mm	↔ mm	kg/m	⊞	Stock	Unit
-	<b>MPZ 41*41*2.50*6 SL</b>	41	41	2.500	6000	2.530	1	✓	m

**MP 41\*41\*2.50 DGL**

**Assembly profile**

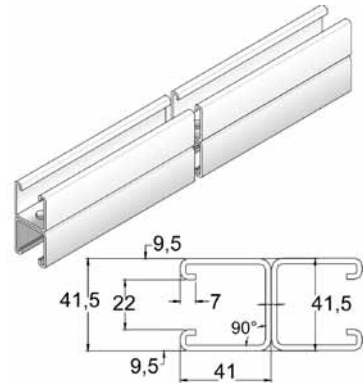

On Demand	Powder coating / Duplex System
Profile opening	22 mm
Standard finish	Hot-dip galvanised

HD	Reference	↑ mm	↔ mm	↔ mm	↔ mm	kg/m	⊞	Stock	Unit
-	<b>MP 41*41*2.50*6 DGL</b>	82	41	2.500	6000	5.330	1	✓	m

**MPZ 41\*41\*2.50 DGL**

**Assembly profile**

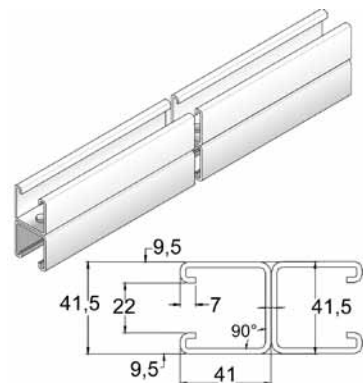

On Demand	Powder coating / Duplex System
Profile opening	22 mm
Standard finish	Pre-galvanised

HD	Reference	↑ mm	↔ mm	↔ mm	↔ mm	kg/m	⊞	Stock	Unit
-	<b>MPZ 41*41*2.50*6 DGL</b>	82	41	2.500	6000	5.330	1	✓	m

# VS 41

## Assembly accessories



On Demand

Powder coating / Duplex System

Standard finish

Hot-dip galvanised

HD	Reference	↑ mm	↔ mm	⊘ mm	↔ mm	kg/piece	📦	Stock	Unit
-	VS 41*01	-	40	5.000	-	0.130	24	✓	piece
-	VS 41*02	-	40	5.000	-	0.190	24	✓	piece
-	VS 41*03	-	40	5.000	-	0.260	24	✓	piece
-	VS 41*04	-	40	5.000	-	0.320	24	✓	piece
-	VS 41*05	-	40	5.000	-	0.130	24	✓	piece
-	VS 41*06	-	40	5.000	-	0.190	24	✓	piece
-	VS 41*07	-	40	5.000	-	0.200	24	✓	piece
-	VS 41*08	-	40	5.000	-	0.260	24	✓	piece
-	VS 41*09	-	40	5.000	-	0.190	24	✓	piece
-	VS 41*10	-	40	5.000	-	0.160	24	✓	piece
-	VS 41*12	-	40	5.000	-	0.260	12	✓	piece
-	VS 41*13	-	40	5.000	-	0.320	12	✓	piece
-	VS 41*14	-	40	5.000	-	0.460	12	✓	piece
-	VS 41*16	-	40	5.000	-	0.270	12	✓	piece
-	VS 41*17	-	40	5.000	-	0.240	12	✓	piece
-	VS 41*18	-	40	5.000	-	0.210	12	✓	piece
-	VS 41*19	-	40	5.000	-	0.270	12	✓	piece
-	VS 41*20	-	40	5.000	-	0.350	12	✓	piece
-	VS 41*25	-	40	5.000	-	0.250	12	✓	piece
-	VS 41*26	-	40	5.000	-	0.360	12	✓	piece
-	VS 41*27	-	40	5.000	-	0.290	12	✓	piece
-	VS 41*28	-	40	5.000	-	0.290	12	✓	piece
-	VS 41*31	-	40	5.000	-	0.340	12	✓	piece
-	VS 41*36	-	40	5.000	-	0.210	12	✓	piece
-	VS 41*37	-	40	5.000	-	0.470	12	✓	piece
-	VS 41*38	-	40	5.000	-	0.640	12	✓	piece
-	VS 41*39	-	40	5.000	-	0.920	12	✓	piece
-	VS 41*41	-	40	5.000	-	0.370	12	✓	piece
-	VS 41*42	-	40	5.000	-	0.330	12	✓	piece
-	VS 41*43	-	40	8.000	-	0.200	12	✓	piece
-	VS 41*44	-	40	5.000	-	0.110	12	✓	piece

More technical specifications for this product can be found at the end of this chapter.

VS 41\*41 / VS 41\*42: Bolt PB 10\*40 inclusive.

**TIM**

**Threaded rod (DIN 975)**



Standard finish

Electro zinc-plated

Reference	Max. load (in daN)
TIM 6	300
TIM 8	550
TIM 10	900
TIM 12	1300

HD	Reference	↑ mm	↔ mm	↖ mm	↗ mm	kg/m	⊠	Stock	Unit
-	<b>TIM 6</b>	-	-	M6	2000	0.170	50	✓	m
-	<b>TIM 8</b>	-	-	M8	2000	0.310	20	✓	m
-	<b>TIM 10</b>	-	-	M10	2000	0.460	20	✓	m
-	<b>TIM 12</b>	-	-	M12	2000	0.700	10	✓	m

To fix with:

HD	<b>M 8</b>	-	-	M8	-	0.010	250	✓	piece
HD	<b>M 12</b>	-	-	M12	-	0.020	250	✓	piece
HD	<b>M 10</b>	-	-	M10	-	0.010	250	✓	piece
HD	<b>RO 12</b>	-	-	M12	-	0.010	250	✓	piece
HD	<b>RO 8</b>	-	-	M8	-	0.010	250	✓	piece
HD	<b>RO 10</b>	-	-	M10	-	0.010	250	✓	piece

**VM 6334**

**Coupling nut (DIN 6334)**

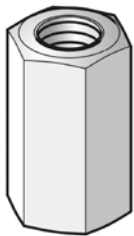

Standard finish

Electro zinc-plated

HD	Reference	↑ mm	↔ mm	↖ mm	↗ mm	kg/piece	⊠	Stock	Unit
-	<b>VM 6</b>	18	-	M6	-	0.010	48	✓	piece
-	<b>VM 8</b>	24	-	M8	-	0.020	48	✓	piece
-	<b>VM 10</b>	30	-	M10	-	0.040	48	✓	piece
-	<b>VM 12</b>	36	-	M12	-	0.060	48	✓	piece

**GM**

**Sliding nut for supporting profile**

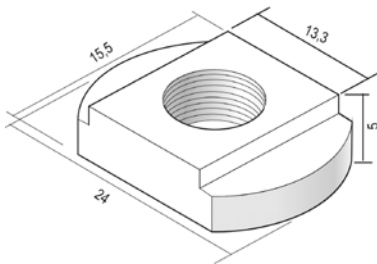

Standard finish

Electro zinc-plated

HD	Reference	↑ mm	↔ mm	↖ mm	↗ mm	kg/piece	⊠	Stock	Unit
-	<b>GM 6</b>	-	-	M6	-	0.010	48	✓	piece
-	<b>GM 8</b>	-	-	M8	-	0.010	48	✓	piece

Fits in the rung of the cable ladder KL.



## GM 41

### Sliding nut for supporting profile

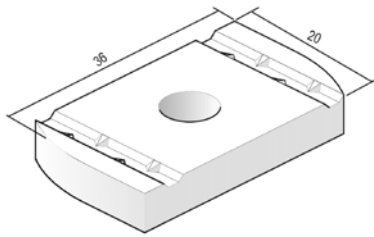

For stepless fixation of the brackets on the ceiling profiles.

Standard finish	Electro zinc-plated
Optional finish 1	Hot-dip galvanised

HD	Reference	↑ mm	↔ mm	↔ mm	↔ mm	kg/piece	📦	Stock	Unit
HD	<b>GM 41 M 6</b>	-	-	M6	-	0.030	48	✓	piece
HD	<b>GM 41 M 8</b>	-	-	M8	-	0.030	48	✓	piece
HD	<b>GM 41 M 10</b>	-	-	M10	-	0.040	48	✓	piece
HD	<b>GM 41 M 12</b>	-	-	M12	-	0.040	48	✓	piece

Used with the profiles MP 41\*21 and MP 41\*41.

## GMV 41

### Sliding nut spring supporting profile



Standard finish	Electro zinc-plated
-----------------	---------------------

HD	Reference	↑ mm	↔ mm	↔ mm	↔ mm	kg/piece	📦	Stock	Unit
-	<b>GMV 41 M 6</b>	-	-	M6	-	0.030	48	✓	piece
-	<b>GMV 41 M 8</b>	-	-	M8	-	0.030	48	✓	piece
-	<b>GMV 41 M 10</b>	-	-	M10	-	0.040	48	✓	piece
-	<b>GMV 41 M 12</b>	-	-	M12	-	0.040	48	✓	piece

## B

### Bolt (DIN 933)

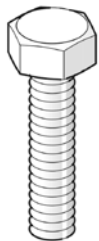

Standard finish	Electro zinc-plated
-----------------	---------------------

HD	Reference	↑ mm	↔ mm	↔ mm	↔ mm	kg/piece	📦	Stock	Unit
-	<b>B 6*20</b>	-	-	M6	20	0.010	250	✓	piece
HD	<b>B 6*30</b>	-	-	M6	30	0.010	250	✓	piece
HD	<b>B 8*20</b>	-	-	M8	20	0.020	250	✓	piece
HD	<b>B 8*30</b>	-	-	M8	30	0.020	250	✓	piece
HD	<b>B 8*40</b>	-	-	M8	40	0.020	250	✓	piece
HD	<b>B 8*50</b>	-	-	M8	50	0.030	250	✓	piece
HD	<b>B 8*70</b>	-	-	M8	70	0.030	250	✓	piece
HD	<b>B 10*20</b>	-	-	M10	20	0.030	250	✓	piece
HD	<b>B 10*30</b>	-	-	M10	30	0.030	250	✓	piece
HD	<b>B 10*40</b>	-	-	M10	40	0.030	250	✓	piece
HD	<b>B 12*20</b>	-	-	M12	20	0.030	250	✓	piece
HD	<b>B 12*30</b>	-	-	M12	30	0.040	250	✓	piece
HD	<b>B 12*40</b>	-	-	M12	40	0.050	250	✓	piece
HD	<b>B 12*50</b>	-	-	M12	50	0.060	250	✓	piece

To order per 250 pieces.

**RBK**

**Toothed round head bolt**



Standard finish

Electro zinc-plated

Optional finish 1

Hot-dip galvanised

HD	Reference	↑ mm	↔ mm	⊘ mm	↔ mm	kg/piece	📦	Stock	Unit
HD	<b>RBK 12*20</b>	-	-	M12	-	0.045	250	✓	piece

To order per 250 pieces.

**M**

**Nut (DIN 934)**

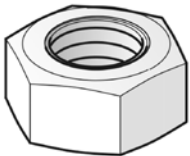

Standard finish

Electro zinc-plated

HD	Reference	↑ mm	↔ mm	⊘ mm	↔ mm	kg/piece	📦	Stock	Unit
-	<b>M 6</b>	-	-	M6	-	0.010	250	✓	piece
HD	<b>M 8</b>	-	-	M8	-	0.010	250	✓	piece
HD	<b>M 10</b>	-	-	M10	-	0.010	250	✓	piece
HD	<b>M 12</b>	-	-	M12	-	0.020	250	✓	piece

According to EN 024-034.  
To order per 250 pieces.

**VM**

**Nut and Bolt**

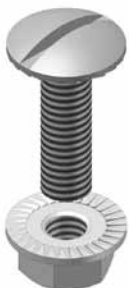

Standard finish

Electro zinc-plated

HD	Reference	↑ mm	↔ mm	⊘ mm	↔ mm	kg/piece	📦	Stock	Unit
-	<b>VM 4*40</b>	-	-	M4	40	0.010	250	✓	piece
HD	<b>VM 6*10</b>	-	-	M6	10	0.010	250	✓	piece
HD	<b>VM 6*20</b>	-	-	M6	20	0.010	250	✓	piece
-	<b>VM 6*50</b>	-	-	M6	50	0.020	250	✓	piece
-	<b>VM 8*16</b>	-	-	M8	16	0.010	250	✓	piece
-	<b>VM 10*50</b>	-	-	M10	50	0.050	250	✓	piece

According to DIN 50 961.  
To order per 250 pieces.

**VMK**

**Toothed round head bolt/nut**

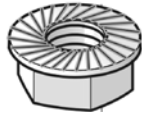
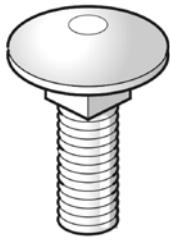

Standard finish

Electro zinc-plated

Optional finish 1

Hot-dip galvanised

HD	Reference	↑ mm	↔ mm	↔ mm	↔ mm	kg/piece	📦	Stock	Unit
HD	<b>VMK 6*10</b>	-	-	M6	-	0.010	250	✓	piece
-	<b>VMK 8*15</b>	-	-	M8	-	0.020	250	✓	piece

To order per 250 pieces.

**RB**

**Bolt**



Standard finish

Electro zinc-plated

HD	Reference	↑ mm	↔ mm	↔ mm	↔ mm	kg/piece	📦	Stock	Unit
-	<b>RB 6*10</b>	-	-	M6	10	0.010	250		piece
-	<b>RB 6*20</b>	-	-	M6	20	0.010	250		piece

To order per 250 pieces.

**RM**

**Flange nut (DIN 6923)**



Standard finish

Electro zinc-plated

HD	Reference	↑ mm	↔ mm	↔ mm	↔ mm	kg/piece	📦	Stock	Unit
-	<b>RM 6</b>	-	-	M6	-	0.010	250		piece

To order per 250 pieces.

**CRO**

**Flat giant washer (DIN 9021)**

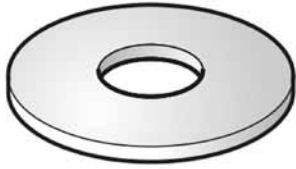

Standard finish

Electro zinc-plated

HD	Reference	↑ mm	↔ mm	⊘ mm	↔ mm	kg/piece	📦	Stock	Unit
-	<b>CRO 6</b>	-	-	M6	-	0.010	250	✓	piece
HD	<b>CRO 8</b>	-	-	M8	-	0.010	250	✓	piece
HD	<b>CRO 10</b>	-	-	M10	-	0.020	250	✓	piece
HD	<b>CRO 12</b>	-	-	M12	-	0.030	250	✓	piece

To order per 250 pieces.

**RO**

**Giant washer (DIN 125-1 A)**

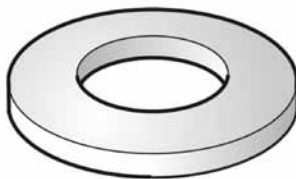

Standard finish

Electro zinc-plated

HD	Reference	↑ mm	↔ mm	⊘ mm	↔ mm	kg/piece	📦	Stock	Unit
-	<b>RO 4</b>	-	-	M4	-	0.010	250	✓	piece
-	<b>RO 6</b>	-	-	M6	-	0.010	250	✓	piece
HD	<b>RO 8</b>	-	-	M8	-	0.010	250	✓	piece
HD	<b>RO 10</b>	-	-	M10	-	0.010	250	✓	piece
HD	<b>RO 12</b>	-	-	M12	-	0.010	250	✓	piece

To order per 250 pieces.

**VSZ**

**Galvaspray 400 ml**



Standard finish

Zinc

HD	Reference	↑ mm	↔ mm	⊘ mm	↔ mm	kg/piece	📦	Stock	Unit
-	<b>VSZ</b>	-	-	-	-	0.450	12	✓	piece

## RBS

## Edge protection



Standard finish

HD	Reference	↕ mm	↔ mm	↔ mm	↔ mm	kg/m	📦	Stock	Unit
-	<b>RBS 0.75*2.50</b>	-	-	-	-	0.040	10	✓	m

To order per 10 m.



**CCLTI**

**Mounting principle**

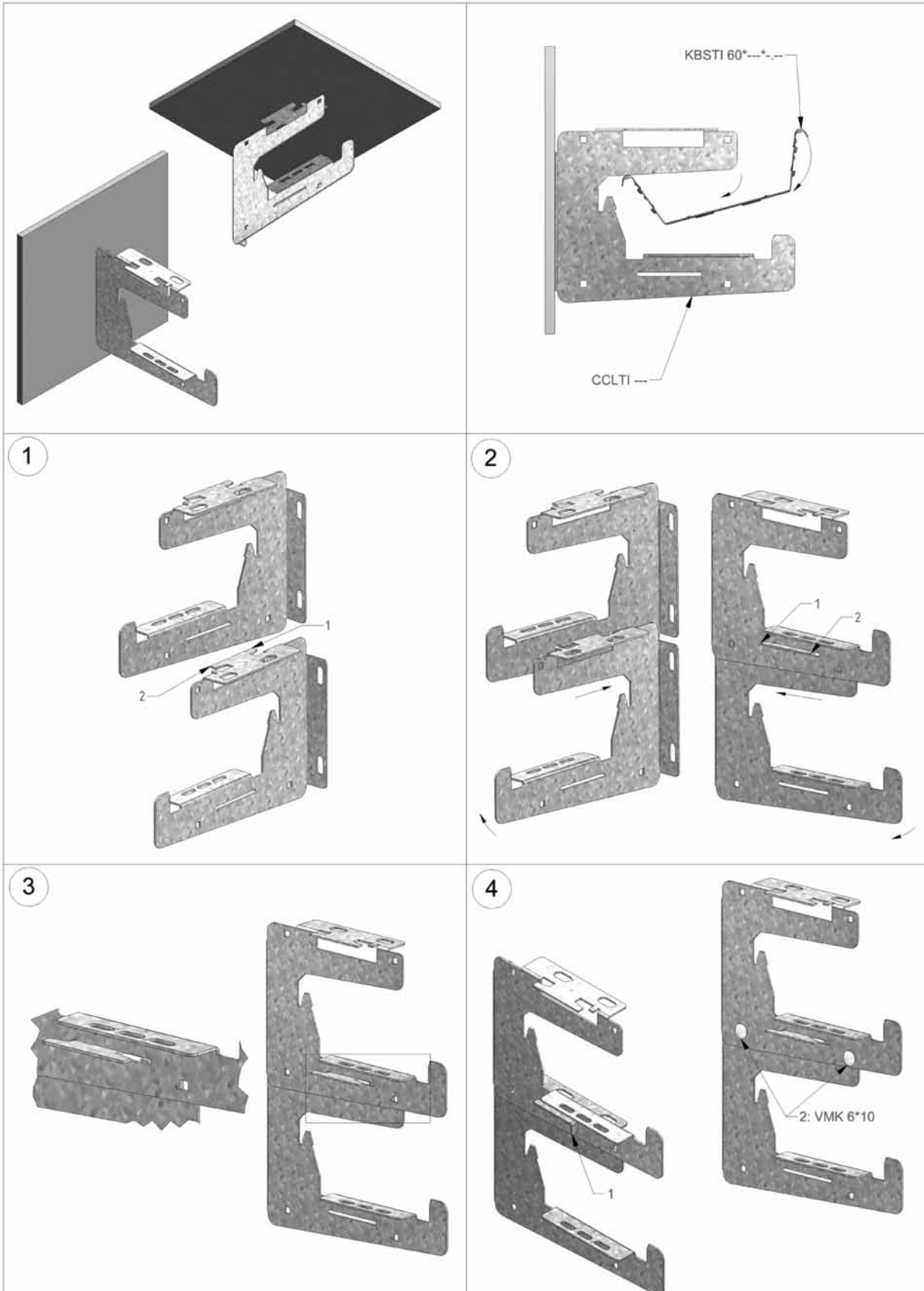

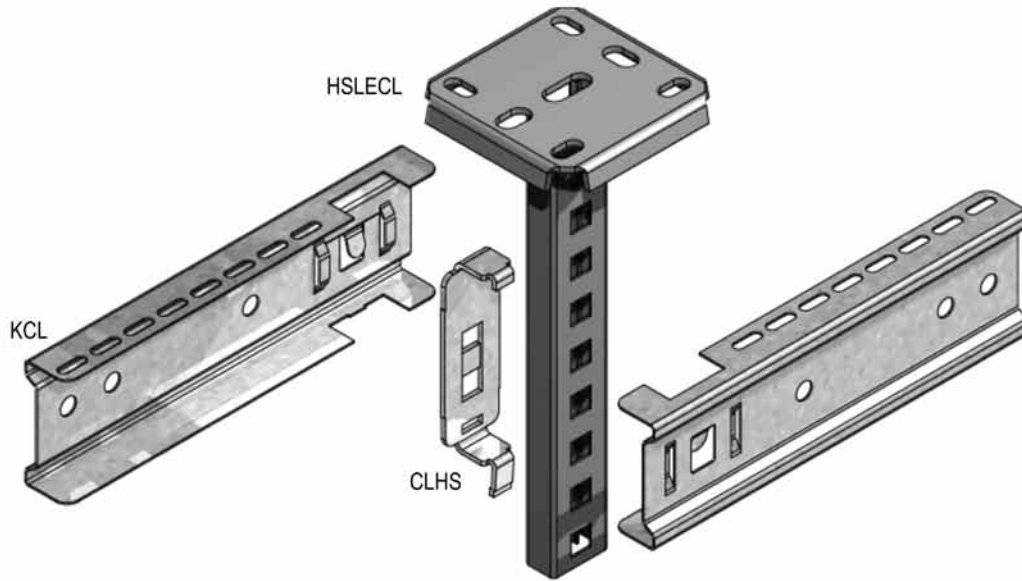
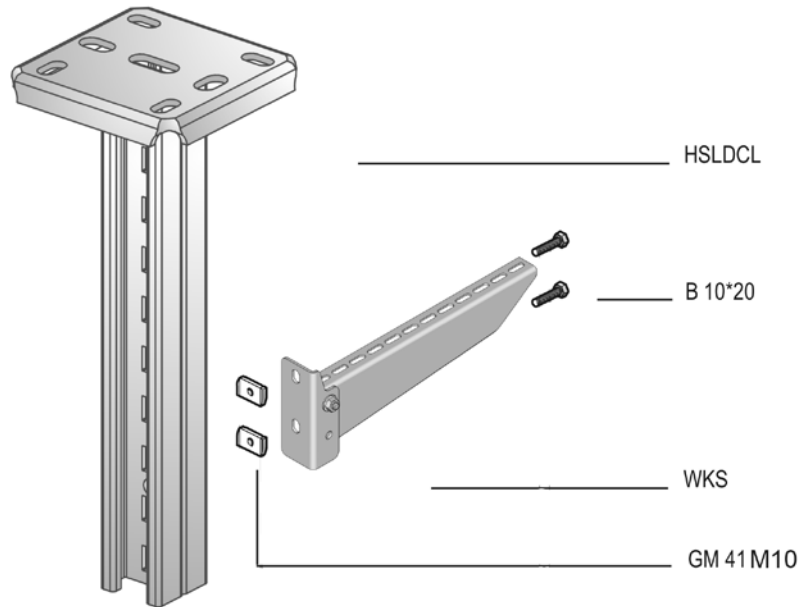
**HSLECL****Mounting principle****HSLDCL****Mounting principle**



**HSME**

**Mounting principle**

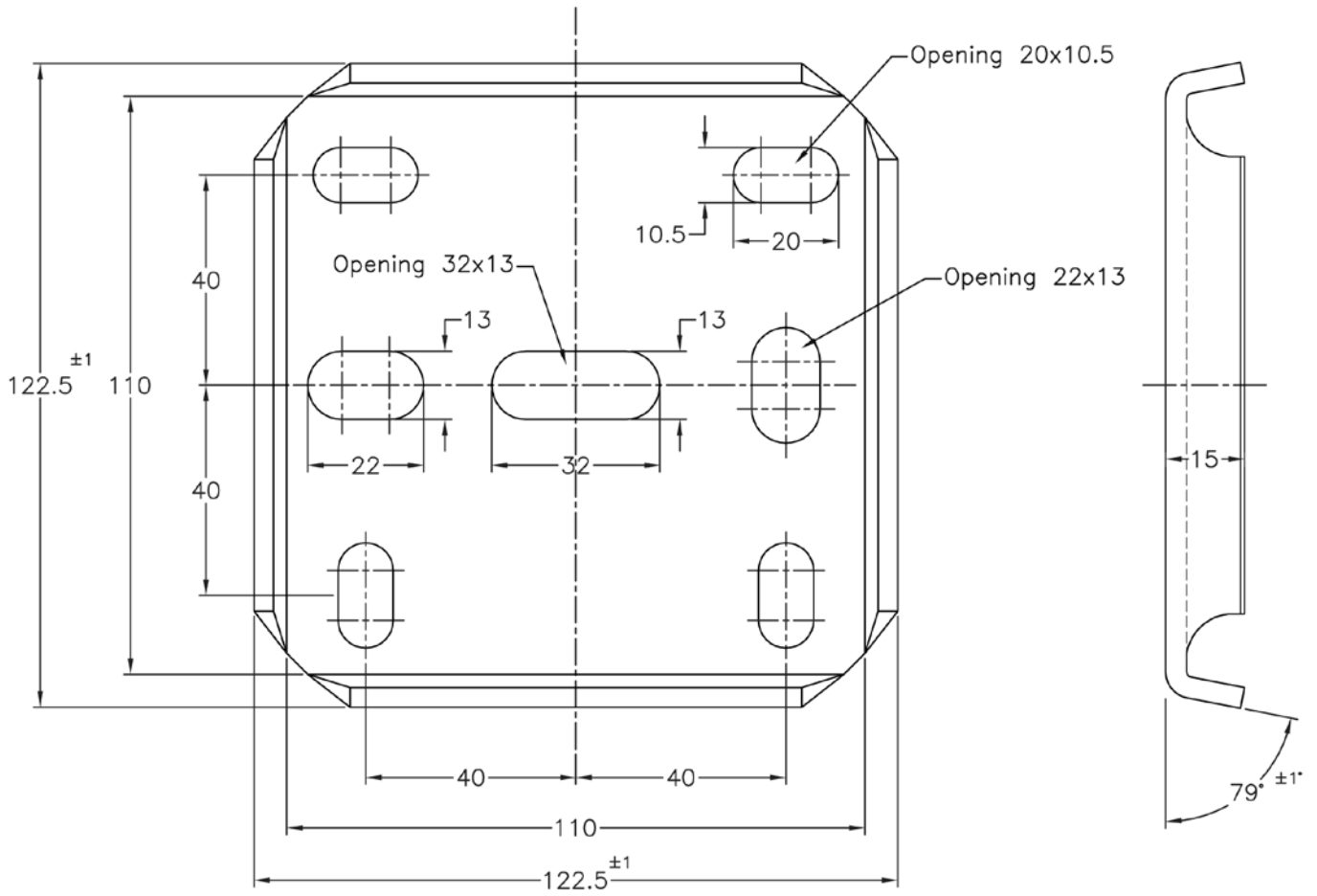

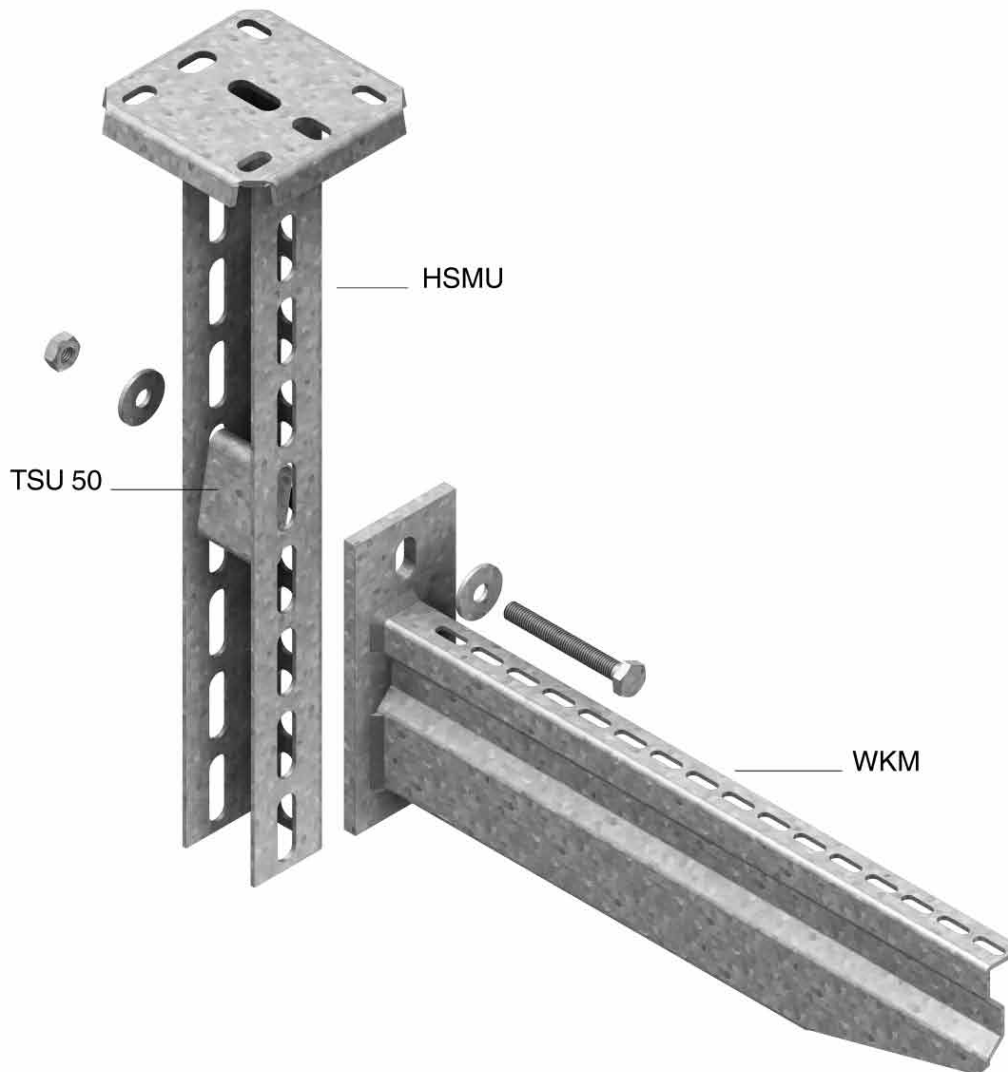
**HSMU****Mounting principle**

**HSIZ**

**Mounting principle**

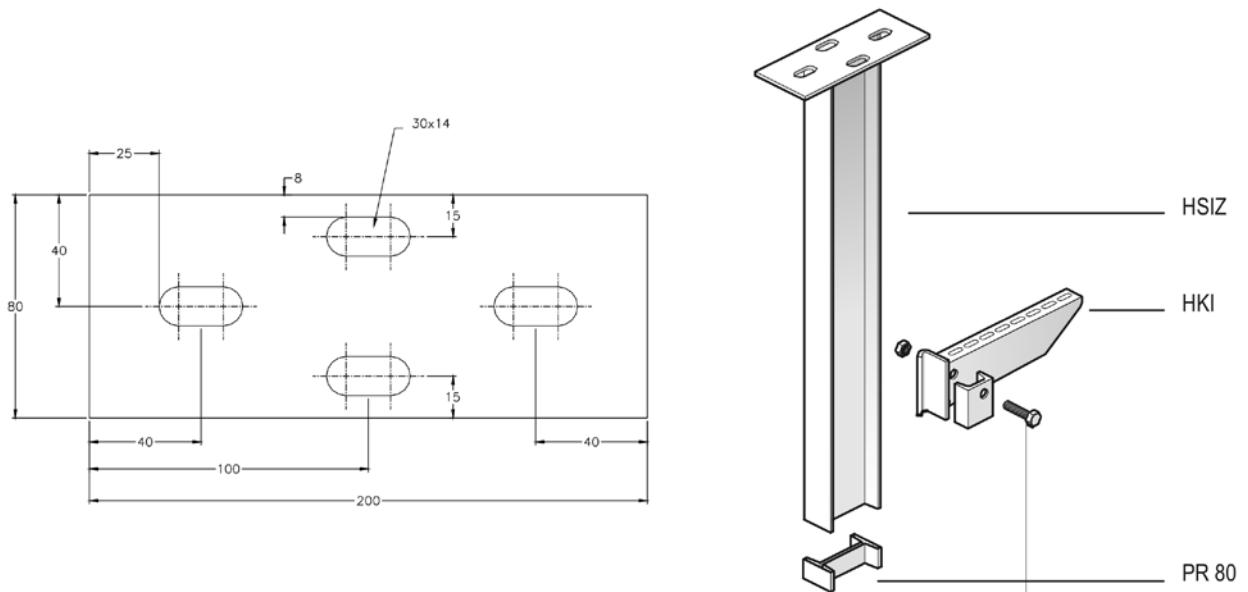

**SKP**

**Mounting principle**

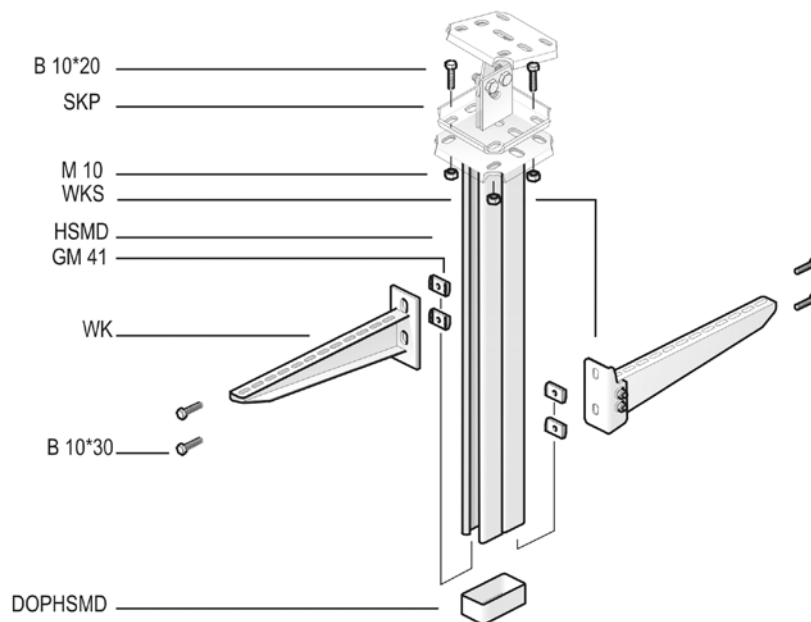

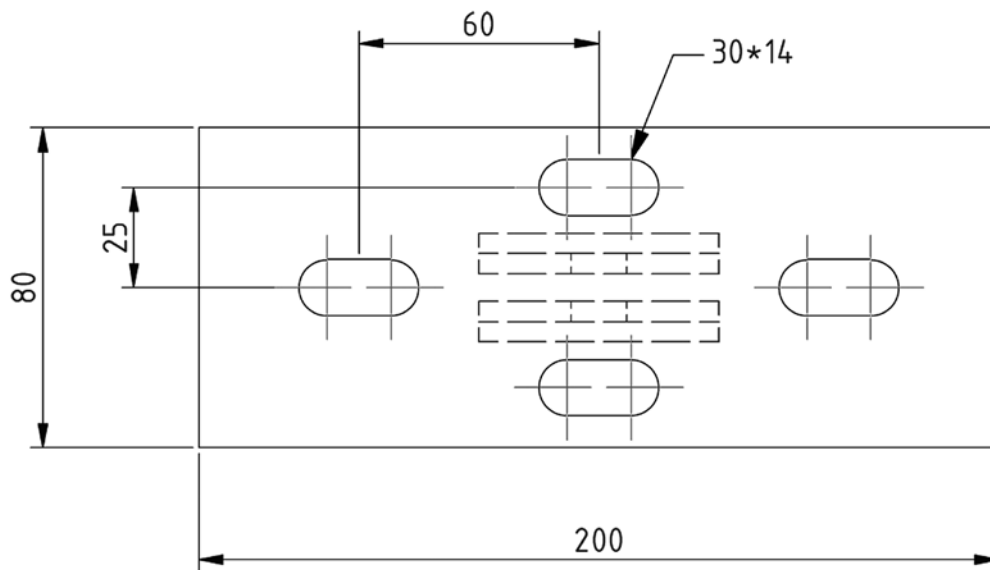
**IPL 06****Mounting principle**

**IPL 10**

**Mounting principle**

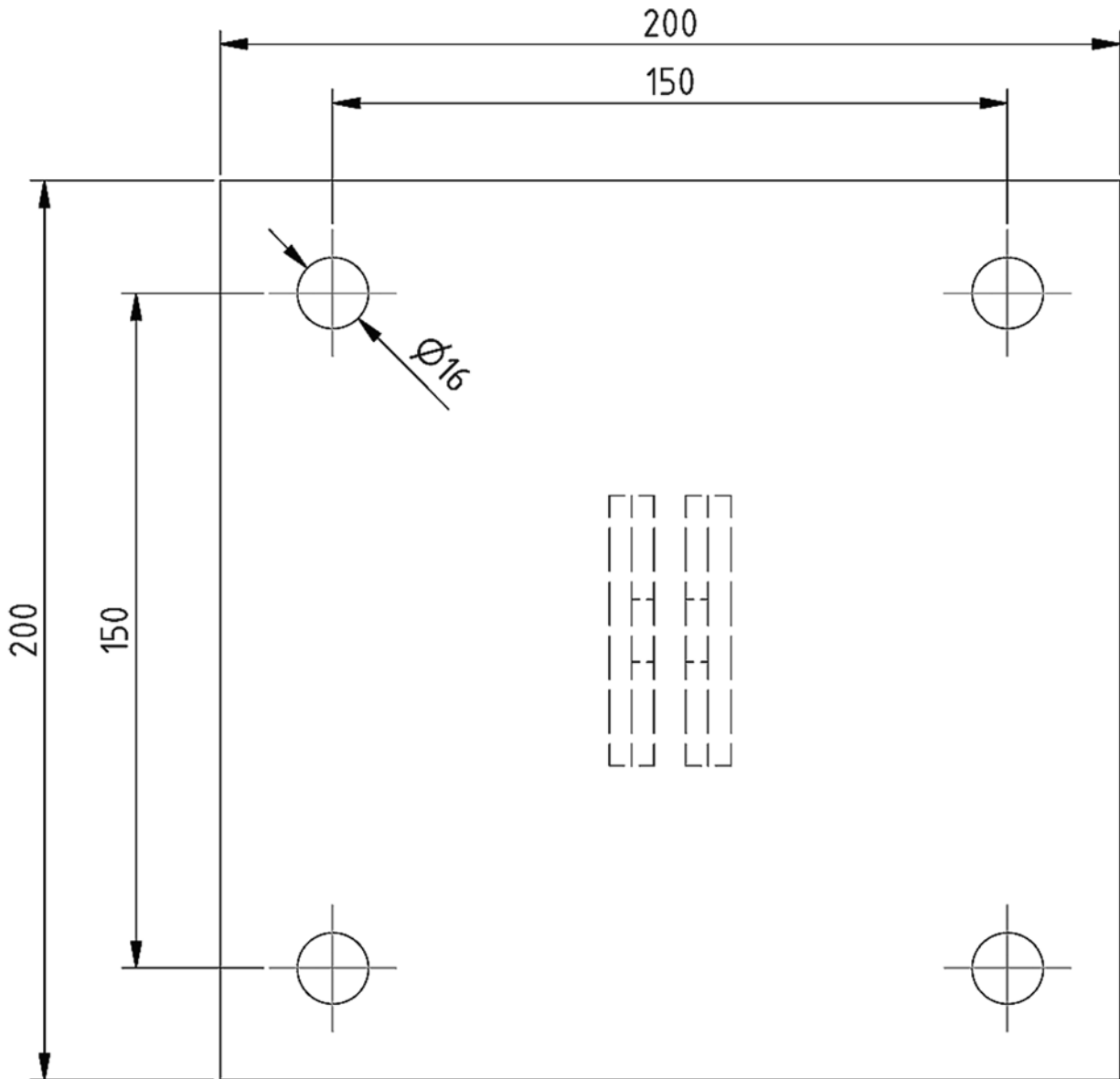

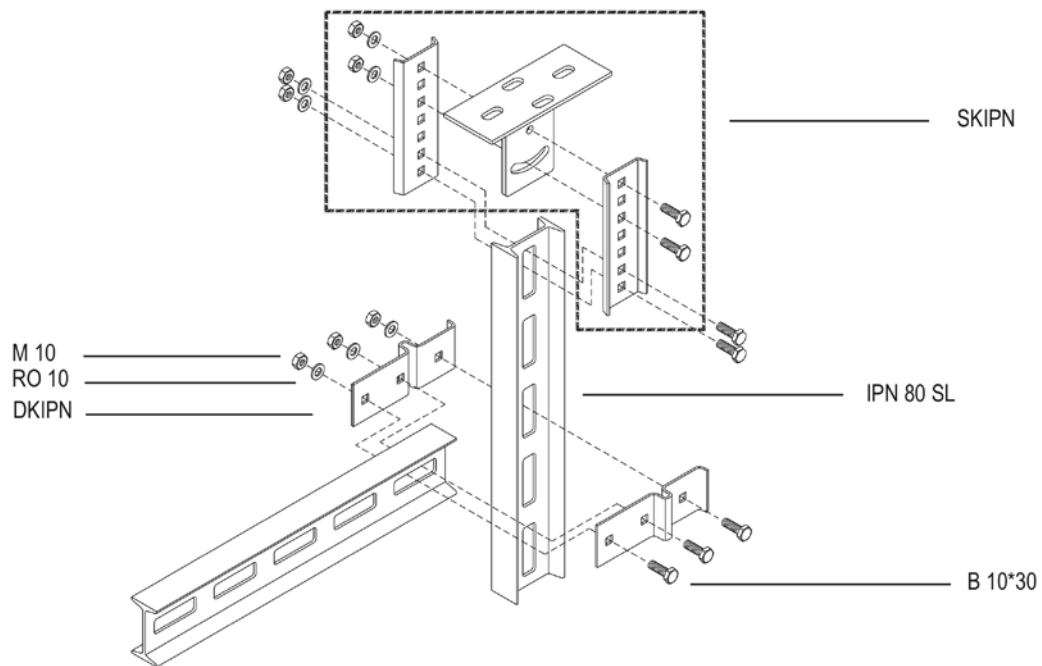
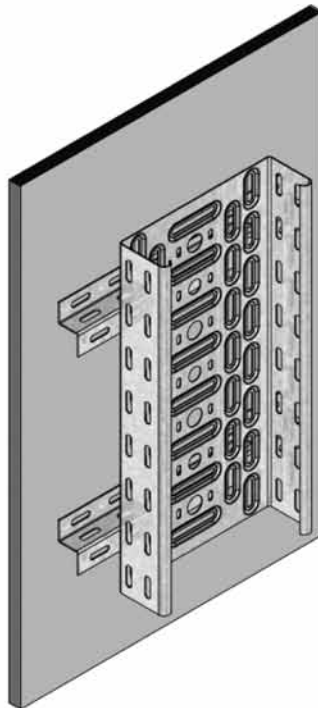
**SKIPN****Mounting principle****5****Z 25****Mounting principle**

**VS 41**

**Mounting principle**



VS 41\*01



VS 41\*02

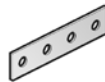

VS 41\*03

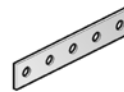

VS 41\*04

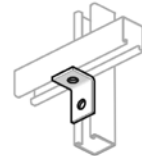

VS 41\*05



VS 41\*06

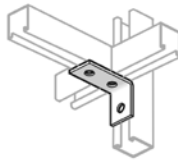

VS 41\*07

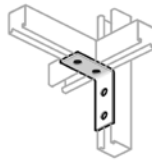

VS 41\*08

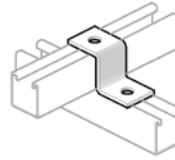

VS 41\*09

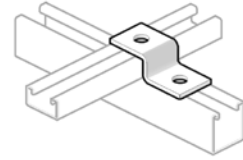

VS 41\*10

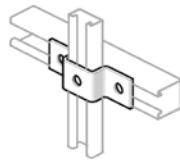

VS 41\*12

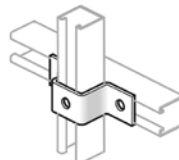

VS 41\*13

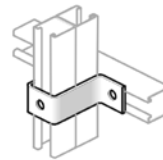

VS 41\*14



VS 41\*16



VS 41\*17



VS 41\*18

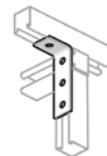

VS 41\*19



VS 41\*20

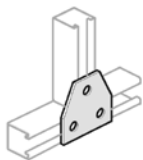

VS 41\*25

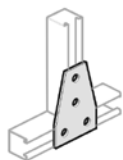

VS 41\*26

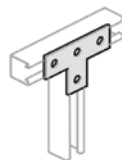

VS 41\*27

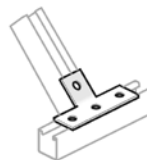

VS 41\*28

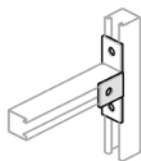

VS 41\*31

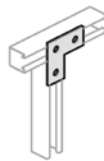

VS 41\*36

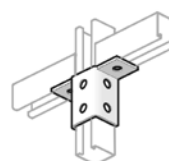

VS 41\*37

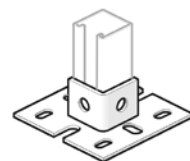

VS 41\*38

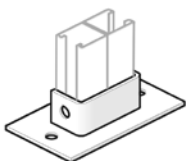

VS 41\*39

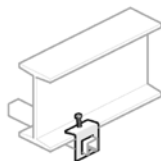

VS 41\*41

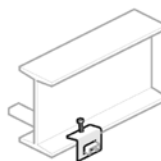

VS 41\*42

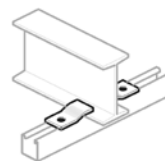

VS 41\*43



VS 41\*44

