

WIRE CABLE TRAYS

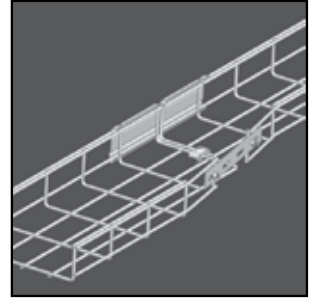

WIRE CABLE TRAYS

	Survey of the system	3-73
VFL		
VFL 35	Wire cable tray	3-75
VFL 60	Wire cable tray	3-76
VF		
VF 35	Wire cable tray heavy duty	3-76
VF 60	Wire cable tray heavy duty	3-77
VF 85	Wire cable tray heavy duty	3-78
VF 110	Wire cable tray heavy duty	3-78
COVER		
D	Universal cover	3-79
COVER CLAMPS		
DCLVF	Captive lid clamp VF/VFL	3-79
DCLVF 35	Captive lid clamp VF/VFL 35	3-80
ACCESSORIES		
VFO	Suspension piece for VF/VFL	3-80
VFM	Wall bracket for VF/VFL	3-80
VFMM	Wall and mounting bracket for VF/VFL	3-81
VFMM 35	Wall and mounting bracket for VF/VFL	3-81
VFCL	Fixation clips VF/VFL	3-81
VFCB	Central suspension bracket for VF/VFL	3-82
OBG	Upper bracket	3-82
VFVLB	Floor bracket for VF/VFL	3-83
ROMEGACL	Supporting profile snap-in	3-83
LOMEGACL 150	Snap-in wall bracket for VF/VFL	3-84
COMEGACL 170	Snap-in suspension bracket for VF/VFL	3-84
VMB	Floor and wall bracket	3-85
SLOS	Division plate free	3-85
VFSLOSCL	Clips SLOS VF/VFL	3-85
MOUNTING PLATES		
VFK	Jointing clamp for VF/VFL	3-86
VFKG 30	Jointing clamp for VF/VFL	3-86
VFKK 25	Jointing clamp for VF/VFL	3-86
VFKS	Support joint for VF/VFL	3-87
KPVF	Snap-on joiner for VF/VFL	3-87
KPVFL 35	Snap quick-jointing plate for VFL 35	3-87
V 35*200	Jointing plate	3-88
TOOLS		
VFKNIP	Bolt cutter	3-88
	TECHNICAL INFORMATION	3-89

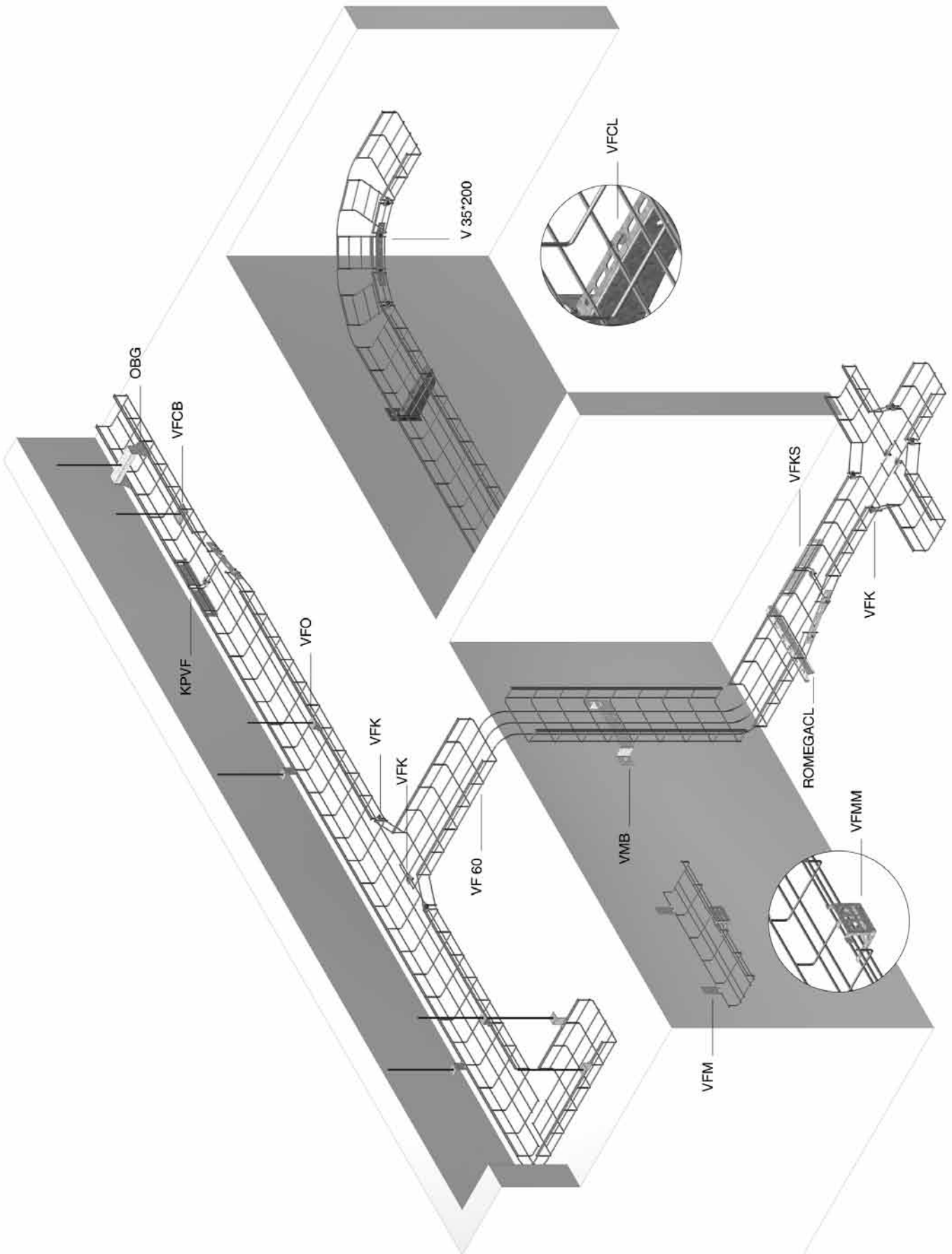

VFL 35

Wire cable tray

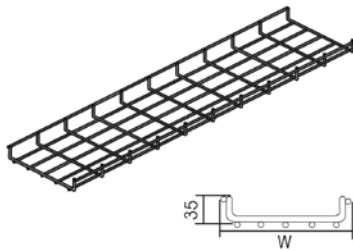

Screen : 50 x 100 mm
 Cross-wire : Ø 3.50 mm
 Alongside wire : Ø 4.50 mm

On Demand	Powder coating / Duplex System
Standard finish	Electro zinc-plated
Optional finish 1	Hot-dip galvanised

HD	Reference	↑ mm	↔ mm	↔ mm	↔ mm	kg/m	⊠	Stock	Unit
HD	VFL 30*065	30	65	-	3000	0.590	15	✓	m
HD	VFL 35*100	35	95	-	3000	0.620	30	✓	m
HD	VFL 35*150	35	146	-	3000	0.920	30	✓	m
HD	VFL 35*200	35	196	-	3000	0.960	30	✓	m
HD	VFL 35*250	35	245	-	3000	1.130	30	✓	m
HD	VFL 35*350	35	345	-	3000	1.460	30	✓	m
HD	VFL 35*450	35	445	-	3000	1.790	30	✓	m
HD	VFL 35*550	35	545	-	3000	2.130	30	✓	m

To fix with:

HD	KPVFL 35	45	248	-	-	0.100	30	✓	piece
HD	VFK	-	-	-	-	0.020	100	✓	piece

LOAD DIAGRAM

Graph valid for VFL 35. This diagram illustrates the permissible uniformly distributed loads applied to multiple supports. They comply with IEC 61537 par 10.3.3 test type III with connection to 1/5 of the span.

F = max. admissible load (daN/m)

L = support distance (m)

Max. deflection (m) = L/100

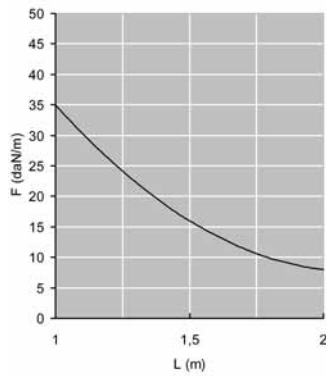

VFL 60

Wire cable tray

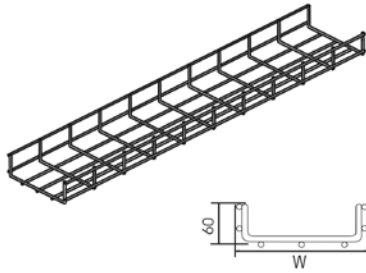

Screen : 50 x 100 mm
 Cross-wire : Ø 3.50 mm
 Alongside wire : Ø 4.50 mm

On Demand	Powder coating / Duplex System
Standard finish	Electro zinc-plated
Optional finish 1	Hot-dip galvanised

HD	Reference	↑ mm	↔ mm	↔ mm	↔ mm	kg/m	⊠	Stock	Unit
HD	VFL 60*050	60	50	-	3000	0.620	30	✓	m
HD	VFL 60*100	60	96	-	3000	0.920	30	✓	m
HD	VFL 60*150	60	146	-	3000	0.960	30	✓	m
HD	VFL 60*200	60	197	-	3000	1.130	30	✓	m
HD	VFL 60*300	60	297	-	3000	1.460	30	✓	m
HD	VFL 60*400	60	397	-	3000	1.790	30	✓	m
HD	VFL 60*500	60	497	-	3000	2.130	30	✓	m

To fix with:									
HD	VFK	-	-	-	-	0.020	100	✓	piece
HD	VFKS	55	250	-	-	0.270	10	✓	piece
HD	KPVF	51	248	-	-	0.100	30	✓	piece

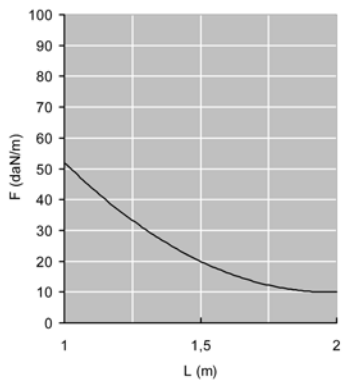

LOAD DIAGRAM

Graph valid for VFL 60. This diagram illustrates the permissible uniformly distributed loads applied to multiple supports. They comply with IEC 61537 par 10.3.3 test type III with connection to 1/5 of the span.

F = max. admissible load (daN/m)
 L = support distance (m)
 Max. deflection (m) = L/100

VF 35

Wire cable tray heavy duty

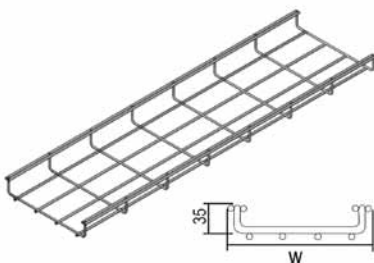

Screen : 50 x 100 mm
 Thread : Ø 4.50 mm

On Demand	Powder coating / Duplex System
Standard finish	Electro zinc-plated
Optional finish 1	Hot-dip galvanised

HD	Reference	↑ mm	↔ mm	↔ mm	↔ mm	kg/m	⊠	Stock	Unit
HD	VF 35*100	35	96	-	3000	0.950	30		m
HD	VF 35*150	35	146	-	3000	1.270	30		m
HD	VF 35*200	35	196	-	3000	1.340	30		m
HD	VF 35*250	35	246	-	3000	1.530	30		m
HD	VF 35*350	35	346	-	3000	1.920	30		m
HD	VF 35*450	35	446	-	3000	2.300	30		m
HD	VF 35*550	35	546	-	3000	2.690	30		m

To fix with:									
HD	VFK	-	-	-	-	0.020	100	✓	piece

WIRE CABLE TRAYS

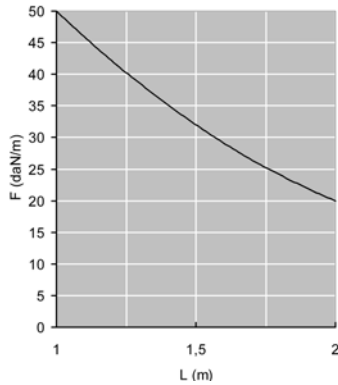

LOAD DIAGRAM

Graph valid for VF 35. This diagram illustrates the permissible uniformly distributed loads applied to multiple supports. They comply with IEC 61537 par 10.3.3 test type III with connection to 1/5 of the span.

F = max. admissible load (daN/m)
 L = support distance (m)
 Max. deflection (m) = L/100

VF 60

Wire cable tray heavy duty

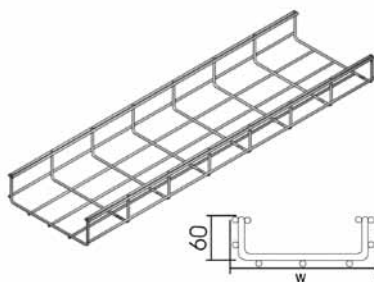

Screen : 50 x 100 mm
 Thread : Ø 4.50 mm

On Demand	Powder coating / Duplex System
Standard finish	Electro zinc-plated
Optional finish 1	Hot-dip galvanised

HD	Reference	↑ mm	↔ mm	↔ mm	↔ mm	kg/m	⊠	Stock	Unit
HD	VF 60*050	60	50	-	3000	0.950	30	✓	m
HD	VF 60*100	60	97	-	3000	1.270	30	✓	m
HD	VF 60*150	60	147	-	3000	1.340	20	✓	m
HD	VF 60*200	60	197	-	3000	1.530	30	✓	m
HD	VF 60*300	60	297	-	3000	1.920	30	✓	m
HD	VF 60*400	60	397	-	3000	2.300	30	✓	m
HD	VF 60*500	60	497	-	3000	2.690	30	✓	m
HD	VF 60*600	60	597	-	3000	3.080	30	✓	m

To fix with:									
HD	VFK	-	-	-	-	0.020	100	✓	piece
HD	VFKS	55	250	-	-	0.270	10	✓	piece
HD	KPVF	51	248	-	-	0.100	30	✓	piece

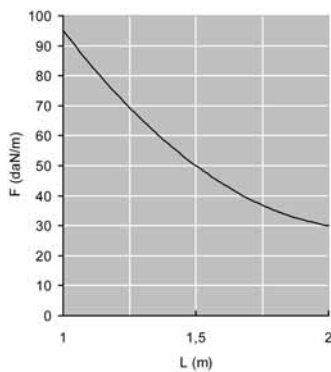

LOAD DIAGRAM

Graph valid for VF 60. This diagram illustrates the permissible uniformly distributed loads applied to multiple supports. They comply with IEC 61537 par 10.3.3 test type III with connection to 1/5 of the span.

F = max. admissible load (daN/m)
 L = support distance (m)
 Max. deflection (m) = L/100

VF 85

Wire cable tray heavy duty

Screen : 50 x 100 mm
Thread : Ø 4.50 mm

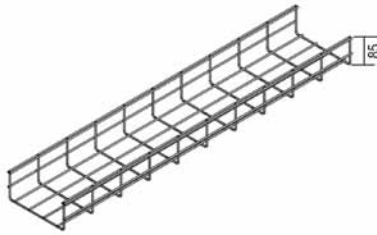

On Demand	Powder coating / Duplex System
Standard finish	Electro zinc-plated
Optional finish 1	Hot-dip galvanised

HD	Reference	↑ mm	↔ mm	↔ mm	↔ mm	kg/m	⊞	Stock	Unit
HD	VF 85*100	78	110	-	3000	1.340	30		m
HD	VF 85*150	85	146	-	3000	1.530	30		m
HD	VF 85*250	85	246	-	3000	1.920	30		m
HD	VF 85*350	85	346	-	3000	2.300	30		m
HD	VF 85*450	85	446	-	3000	2.690	30		m

To fix with:									
HD	VFK	-	-	-	-	0.020	100	✓	piece

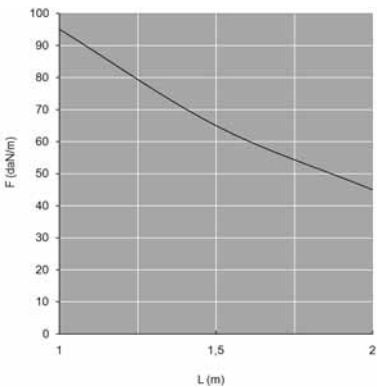

LOAD DIAGRAM

Graph valid for VF 85. This diagram illustrates the permissible uniformly distributed loads applied to multiple supports. They comply with IEC 61537 par 10.3.3 test type III with connection to 1/5 of the span.

F = max. admissible load (daN/m)
L = support distance (m)
Max. deflection (m) = L/100

VF 110

Wire cable tray heavy duty

Screen : 50 x 100 mm
Thread : Ø 4.50 mm

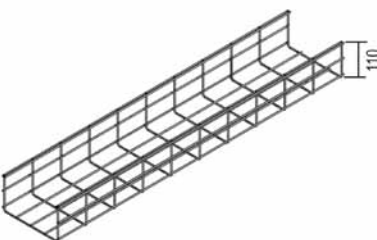

On Demand	Powder coating / Duplex System
Standard finish	Electro zinc-plated
Optional finish 1	Hot-dip galvanised

HD	Reference	↑ mm	↔ mm	↔ mm	↔ mm	kg/m	⊞	Stock	Unit
HD	VF 110*200	110	197	-	3000	1.920	30		m
HD	VF 110*300	110	297	-	3000	2.300	30		m
HD	VF 110*400	110	397	-	3000	2.690	30		m

To fix with:									
HD	VFK	-	-	-	-	0.020	100	✓	piece

WIRE CABLE TRAYS

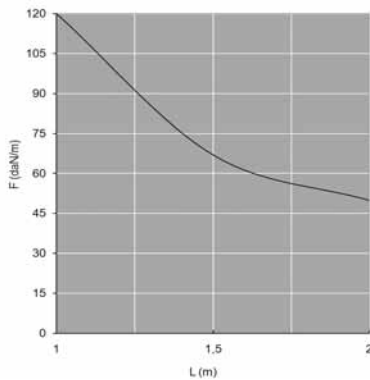

LOAD DIAGRAM

Graph valid for VF 110. This diagram illustrates the permissible uniformly distributed loads applied to multiple supports. They comply with IEC 61537 par 10.3.3 test type III with connection to 1/5 of the span.

F = max. admissible load (daN/m)

L = support distance (m)

Max. deflection (m) = L/100

D

Universal cover

Especially used for horizontal en vertical sections.
Cover with board height 10 mm.

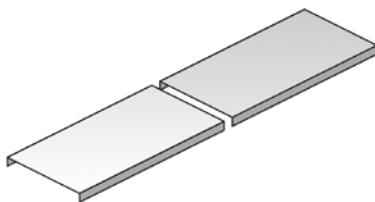

On Demand	Powder coating / Duplex System
Standard finish	Pre-galvanised
Optional finish 1	Hot-dip galvanised

HD	Reference	↑ mm	↔ mm	↔ mm	↔ mm	kg/m	⊞	Stock	Unit
HD	D 050	10	50	-	3000	0.350	3	✓	m
HD	D 075	10	75	-	2000	0.500	10	✓	m
HD	D 100	10	100	-	2000	0.820	10	✓	m
HD	D 150	10	150	-	2000	1.170	10	✓	m
HD	D 200	10	200	-	2000	1.420	10	✓	m
HD	D 250	10	250	-	2000	1.850	10	✓	m
HD	D 300	10	300	-	2000	2.100	10	✓	m
HD	D 400	10	400	-	2000	4.150	10	✓	m
HD	D 500	10	500	-	2000	5.000	10	✓	m
HD	D 600	10	600	-	2000	5.650	10	✓	m

To fix with:

-	DCLVF	-	-	-	-	0.010	100	✓	piece
-	DCLVF 35	-	-	-	-	0.010	100	✓	piece

Covers with width > 400 mm are delivered with diagonal reinforcements.

DCLVF

Captive lid clamp VF/VFL

QUICK & CLICK



For VFL 60, VF 60, VF 85 and VF 110.

Standard finish	Stainless Steel 316
-----------------	---------------------

HD	Reference	↑ mm	↔ mm	↔ mm	↔ mm	kg/piece	⊞	Stock	Unit
-	DCLVF	-	-	-	-	0.010	100	✓	piece

More technical specifications for this product can be found at the end of this chapter.

2 pieces per meter.

DCLVF 35

QUICK & CLICK

Captive lid clamp VF/VFL 35



For VFL 35 and VF 35.

Standard finish		Stainless Steel 316							
HD	Reference	↑ mm	↔ mm	↔ mm	↔ mm	↔ mm	kg/piece	Stock	Unit
-	DCLVF 35	-	-	-	-	-	0.010	100	✓ piece

More technical specifications for this product can be found at the end of this chapter.
2 pieces per meter. Do not use with : VFL 30*065.

VFO

Suspension piece for VF/VFL

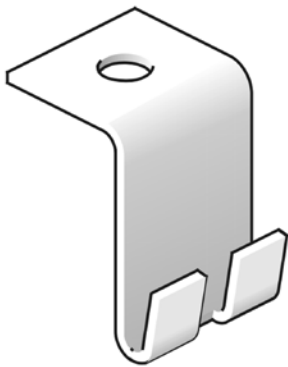

On Demand		Powder coating / Duplex System							
Standard finish		Pre-galvanised							
Optional finish 1		Hot-dip galvanised							
HD	Reference	↑ mm	↔ mm	↔ mm	↔ mm	↔ mm	kg/piece	Stock	Unit
HD	VFO	-	-	-	-	-	0.030	48	✓ piece

For threaded rod suspension M6/M8.
Threaded rod 'TIM 6' or 'TIM 8' should be ordered separately.

VFM

Wall bracket for VF/VFL

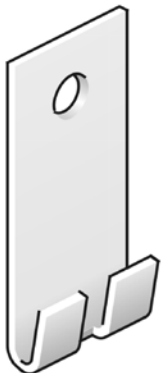

For fixation on the wall.									
On Demand		Powder coating / Duplex System							
Standard finish		Pre-galvanised							
Optional finish 1		Hot-dip galvanised							
HD	Reference	↑ mm	↔ mm	↔ mm	↔ mm	↔ mm	kg/piece	Stock	Unit
HD	VFM	-	-	-	-	-	0.030	48	✓ piece

Up to width 200 mm.

VFMM

Wall and mounting bracket for VF/VFL

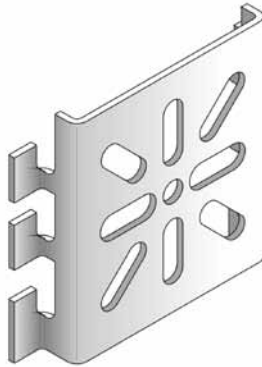

For VF 60 / VFL 60

On Demand Powder coating / Duplex System

Standard finish Pre-galvanised

Optional finish 1 Hot-dip galvanised

HD	Reference	↑ mm	↔ mm	↔ mm	↔ mm	kg/piece	📦	Stock	Unit
HD	VFMM	75	-	-	-	0.090	30	✓	piece

More technical specifications for this product can be found at the end of this chapter.

VFMM 35

Wall and mounting bracket for VF/VFL

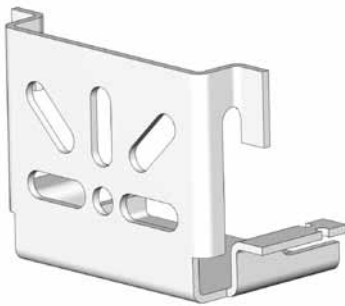

For VF 35 / VFL 35

On Demand Powder coating / Duplex System

Standard finish Pre-galvanised

Optional finish 1 Hot-dip galvanised

HD	Reference	↑ mm	↔ mm	↔ mm	↔ mm	kg/piece	📦	Stock	Unit
HD	VFMM 35	57	-	-	-	0.120	30	✓	piece

VFCL

Fixation clips VF/VFL

QUICK & CLICK



For fixation of wire cable tray on the bracket.

Standard finish Electro zinc-plated

HD	Reference	↑ mm	↔ mm	↔ mm	↔ mm	kg/piece	📦	Stock	Unit
-	VFCL	-	-	-	-	0.010	96	✓	piece

VFCB

Central suspension bracket for VF/VFL



On Demand	Powder coating / Duplex System
Standard finish	Pre-galvanised
Optional finish 1	Hot-dip galvanised

HD	Reference	↑ mm	↔ mm	↔ mm	↔ mm	kg/set	⊞	Stock	Unit
HD	VFCB	-	-	-	-	0.070	30	✓	set

Per set (2 pieces)
 Can be used for wire cable trays VFL/VF 35*100, VFL/VF 60*100 and VFL/VF 60*150.
 For threaded rod suspension M6/M8.
 Threaded rod TIM 6 or TIM 8 and nut M 6 or M 8 should be ordered separately.

OBG

Upper bracket

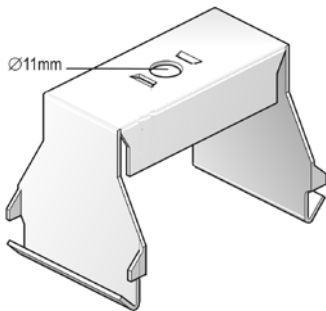

To mount cable trays with partition.

On Demand	Powder coating / Duplex System
Standard finish	Pre-galvanised
Optional finish 1	Hot-dip galvanised

	Max. Load (in daN)
OBG 050	200
OBG 075	200
OBG 100	200
OBG 150	200
OBG 200	200
OBG 250	150
OBG 300	150
OBG 400	90

HD	Reference	↑ mm	↔ mm	↔ mm	↔ mm	kg/piece	⊞	Stock	Unit
HD	OBG 050	64	55	-	-	0.100	12	✓	piece
HD	OBG 075	64	80	-	-	0.130	12	✓	piece
HD	OBG 100	64	105	-	-	0.140	12	✓	piece
HD	OBG 150	64	155	-	-	0.190	12	✓	piece
HD	OBG 200	64	205	-	-	0.220	12	✓	piece
HD	OBG 250	64	255	-	-	0.270	12	✓	piece
HD	OBG 300	64	305	-	-	0.310	6	✓	piece
HD	OBG 400	64	405	-	-	0.390	6	✓	piece

To be mounted with threaded rod TIM 8 or TIM 10.

VFVLB

Floor bracket for VF/VFL

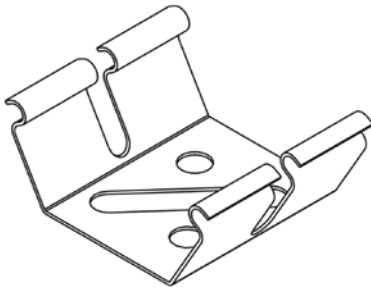

Standard finish

Electro zinc-plated

HD	Reference	↑ mm	↔ mm	↔ mm	↔ mm	kg/piece	⊞	Stock	Unit
-	VFVLB	-	-	-	-	0.030	30	✓	piece

Up to width 250 mm, minimum 2 pieces per meter.
As from width 300 mm, minimum 4 pieces per meter.

ROMEGACL

Supporting profile snap-in

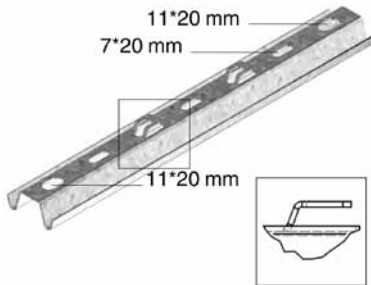

Suitable as floor bracket or for mounting with threaded rod TIM 8 or TIM 10.

On Demand	Powder coating
Standard finish	Pre-galvanised
Optional finish 1	Hot-dip galvanised

Length	Max. load (in daN)
200	350
300	250
350	200
450	150
550	100

HD	Reference	↑ mm	↔ mm	↔ mm	↔ mm	kg/piece	⊞	Stock	Unit
HD	ROMEGACL 200	-	-	-	200	0.220	12	✓	piece
HD	ROMEGACL 300	-	-	-	300	0.320	12	✓	piece
HD	ROMEGACL 350	-	-	-	350	0.370	12	✓	piece
HD	ROMEGACL 450	-	-	-	450	0.480	12	✓	piece
HD	ROMEGACL 550	-	-	-	550	0.590	12	✓	piece

When used as floor bracket, please combine the following products :

ROMEGACL 200 : VF(L) 35*100, VF(L) 35*150, VF(L) 60*100, VL(F) 60*150, VF 85*100
 ROMEGACL 300 : VF(L) 35*200
 ROMEGACL 350 : VF(L) 35*250, VF(L) 60*200, VF(L) 60*300, VF 85*250, VF 110*200, VF 110*300
 ROMEGACL 450 : VF(L) 35*350, VF(L) 60*400, VF 85*350, VF 110*400
 ROMEGACL 550 : VF(L) 35*450, VF(L) 60*500, VF 85*450

When used for mounting with threaded rod, please combine the following products :

ROMEGACL 200 : VF(L) 35*100, VF(L) 60*100, VF 85*100
 ROMEGACL 300 : VF(L) 35*150, VF(L) 35*200, VF(L) 60*150
 ROMEGACL 350 : VF(L) 60*200, VF 110*200
 ROMEGACL 450 : VF(L) 35*250, VF(L) 35*350, VF(L) 60*300, VF 85*250, VF 85*350, VF 110*300
 ROMEGACL 550 : VF(L) 35*450, VF(L) 60*400, VF 85*350, VF 85*450, VF 110*400

LOMEGACL 150

QUICK & CLICK

Snap-in wall bracket for VF/VFL

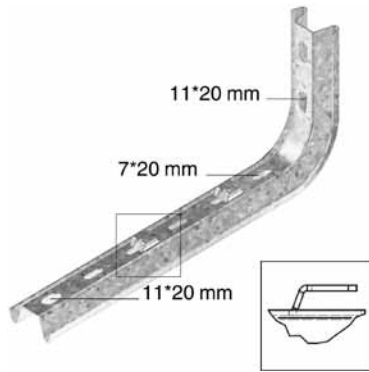

On Demand	Powder coating
Standard finish	Pre-galvanised
Optional finish 1	Hot-dip galvanised

Width	Max. load (in daN)
200	350
300	250
350	200
450	150
550	100

HD	Reference	↑ mm	↔ mm	↔ mm	↔ mm	kg/piece	⊞	Stock	Unit
HD	LOMEGACL 150*150	145	195	-	-	0.330	12	✓	piece
HD	LOMEGACL 150*200	145	245	-	-	0.380	12	✓	piece
HD	LOMEGACL 150*300	145	345	-	-	0.480	12	✓	piece
HD	LOMEGACL 150*400	145	445	-	-	0.590	6	✓	piece

To use with :

LOMEGACL 150*150 : VF(L) 35*100, VF(L) 35*150, VF(L) 60*100, VF(L) 60*150
 LOMEGACL 150*200 : VF(L) 35*150, VF(L) 35*200, VF(L) 60*150, VF(L) 60*200
 LOMEGACL 150*300 : VF(L) 35*200, VF(L) 35*250, VF(L) 60*200, VF(L) 60*300
 LOMEGACL 150*400 : VF(L) 35*350, VF(L) 60*300, VF(L) 60*400

Max. load (in daN): Uniformly distributed load (UDL) over complete width of cantilever brackets.

COMEGACL 170

QUICK & CLICK

Snap-in suspension bracket for VF/VFL

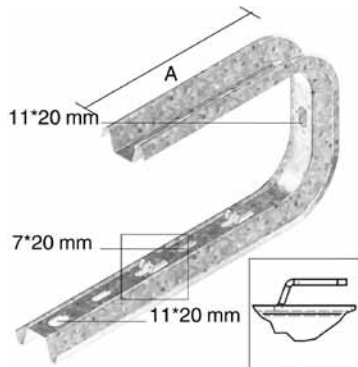

Useful for direct mounting to the ceiling or with threaded rod TIM 8 or TIM 10.

On Demand	Powder coating
Standard finish	Pre-galvanised
Optional finish 1	Hot-dip galvanised

Width	Max. load (in daN)	A
150	60	147
200	60	172
300	50	222
400	40	272

HD	Reference	↑ mm	↔ mm	↔ mm	↔ mm	kg/piece	⊞	Stock	Unit
HD	COMEGACL 170*150	170	182	-	-	0.460	12	✓	piece
HD	COMEGACL 170*200	170	232	-	-	0.540	12	✓	piece
HD	COMEGACL 170*300	170	332	-	-	0.700	12	✓	piece
HD	COMEGACL 170*400	170	432	-	-	0.860	6	✓	piece

To use with :

COMEGACL 170*150 : VF(L) 35*100, VF(L) 35*150, VF(L) 60*100, VF(L) 60*150
 COMEGACL 170*200 : VF(L) 35*150, VF(L) 60*150, VF(L) 60*200
 COMEGACL 170*300 : VF(L) 35*200, VF(L) 35*250, VF(L) 60*200, VF(L) 60*300
 COMEGACL 170*400 : VF(L) 35*350, VF(L) 60*300, VF(L) 60*400

Max. load (in daN) : uniformly distributed over complete width of cantilever brackets.

VMB

Floor and wall bracket

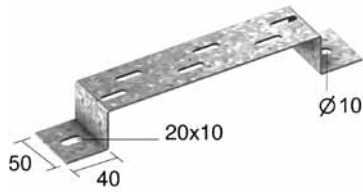

Suitable as floor-, wall-, and suspension bracket.

On Demand	Powder coating / Duplex System
Max. load	200 daN
Standard finish	Pre-galvanised
Optional finish 1	Hot-dip galvanised

HD	Reference	↑ mm	↔ mm	↔ mm	↔ mm	kg/piece	📦	Stock	Unit
HD	VMB 100	40	100	-	-	0.190	30	✓	piece
HD	VMB 150	40	150	-	-	0.220	30	✓	piece
HD	VMB 200	40	200	-	-	0.260	30	✓	piece
HD	VMB 300	40	300	-	-	0.330	30	✓	piece
HD	VMB 400	40	400	-	-	0.390	30	✓	piece
HD	VMB 500	40	500	-	-	0.460	30	✓	piece
HD	VMB 600	40	600	-	-	0.530	30	✓	piece

More technical specifications for this product can be found at the end of this chapter.

Floor bracket and suspension bracket : to mount with VFCL.

Wall bracket : to mount with VFK.

SLOS

Division plate free

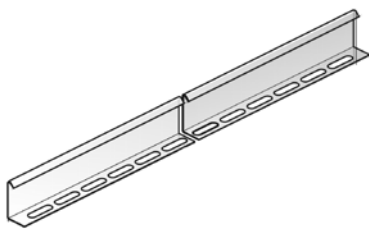

On Demand	Powder coating / Duplex System
Standard finish	Pre-galvanised
Optional finish 1	Hot-dip galvanised

HD	Reference	↑ mm	↔ mm	↔ mm	↔ mm	kg/m	📦	Stock	Unit
HD	SLOS 35	35	-	-	3000	0.330	150	✓	m
HD	SLOS 60	60	-	-	3000	0.510	120	✓	m
HD	SLOS 85	85	-	-	3000	0.680	60	✓	m
HD	SLOS 110	110	-	-	3000	0.820	3	✓	m

To fix with:

HD	VFK	-	-	-	-	0.020	100	✓	piece
-	VFSLOSCL	-	-	-	-	0.010	100	✓	piece

More technical specifications for this product can be found at the end of this chapter.

Fixation set : 1 per meter.

VFSLOSCL

Clips SLOS VF/VFL



Standard finish	Spring steel
-----------------	--------------

HD	Reference	↑ mm	↔ mm	↔ mm	↔ mm	kg/piece	📦	Stock	Unit
-	VFSLOSCL	-	-	-	-	0.010	100	✓	piece



VFK

Jointing clamp for VF/VFL

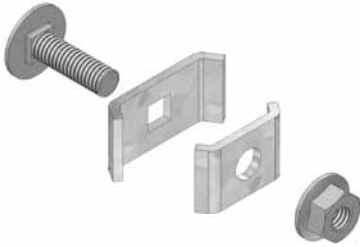

On Demand	Powder coating / Duplex System
Standard finish	Pre-galvanised
Optional finish 1	Hot-dip galvanised

HD	Reference	↑ mm	↔ mm	↔ mm	↔ mm	kg/piece	📦	Stock	Unit
HD	VFK	-	-	-	-	0.020	100	✓	piece

More technical specifications for this product can be found at the end of this chapter.
Bolt RBK 6*20 and nut RM 6 inclusive.

VFKG 30

Jointing clamp for VF/VFL



On Demand	Powder coating / Duplex System
Standard finish	Pre-galvanised
Optional finish 1	Hot-dip galvanised

HD	Reference	↑ mm	↔ mm	↔ mm	↔ mm	kg/piece	📦	Stock	Unit
HD	VFKG 30	-	30	-	-	0.020	200	✓	piece

VFKK 25

Jointing clamp for VF/VFL

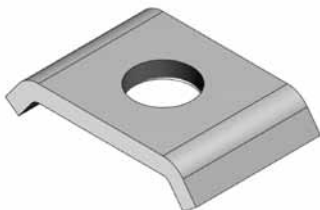

On Demand	Powder coating / Duplex System
Standard finish	Pre-galvanised
Optional finish 1	Hot-dip galvanised

HD	Reference	↑ mm	↔ mm	↔ mm	↔ mm	kg/piece	📦	Stock	Unit
HD	VFKK 25	-	25	-	-	0.020	200	✓	piece

VFKS

Support joint for VF/VFL



For maximum stability and safety. Can only be used with VF 60 / VFL 60.

On Demand	Powder coating / Duplex System
Standard finish	Pre-galvanised
Optional finish 1	Hot-dip galvanised

HD	Reference	↑ mm	↔ mm	↔ mm	↔ mm	kg/piece	📦	Stock	Unit
HD	VFKS	55	250	-	-	0.270	10	✓	piece

3x bolt RBK 6*20, 3x nut RM 6 and 3x VFKG 30 inclusive.

KPVF

Snap-on joiner for VF/VFL

QUICK & CLICK



For a quick jointing without bolts and nuts. Can only be used with VFL 60 and VF 60.

On Demand	Powder coating / Duplex System
Standard finish	Pre-galvanised
Optional finish 1	Hot-dip galvanised

HD	Reference	↑ mm	↔ mm	↔ mm	↔ mm	kg/piece	📦	Stock	Unit
HD	KPVF	51	248	-	-	0.100	30	✓	piece

KPVFL 35

Snap quick-jointing plate for VFL 35

QUICK & CLICK



For screwless connection of VFL 35.

On Demand	Powder coating / Duplex System
Standard finish	Pre-galvanised
Optional finish 1	Hot-dip galvanised

HD	Reference	↑ mm	↔ mm	↔ mm	↔ mm	kg/piece	📦	Stock	Unit
HD	KPVFL 35	45	248	-	-	0.100	30	✓	piece

Do not use with VFL 30*065.

V 35*200

Jointing plate

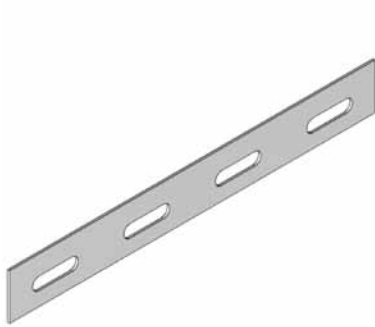

On Demand	Powder coating / Duplex System
Standard finish	Pre-galvanised
Optional finish 1	Hot-dip galvanised

HD	Reference	mm	mm	mm	mm	kg/piece		Stock	Unit
HD	V 35*200	25	200	-	-	0.040	48	✓	piece

VFKNIP

Bolt cutter



Bolt cutter with offset cut
Standard finish

HD	Reference	mm	mm	mm	mm	kg/piece		Stock	Unit
-	VFKNIP	-	-	-	-	0.750	1	✓	piece

3

DCLVF

Mounting principle

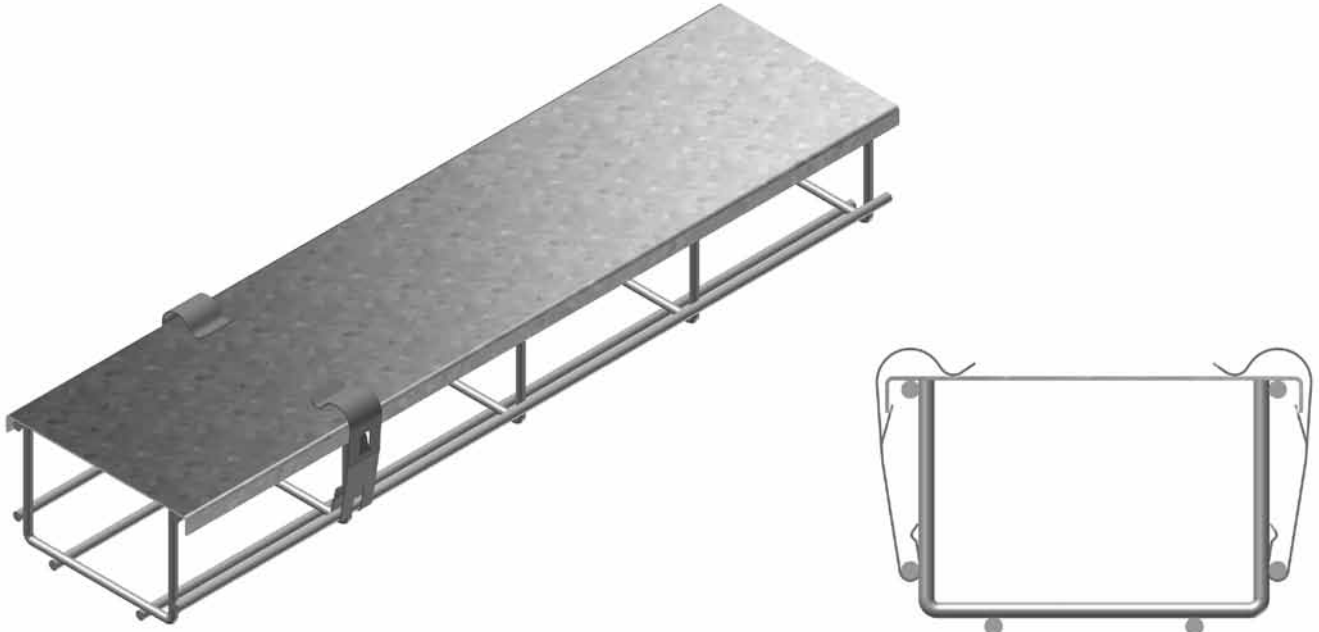

For VFL 60, VF 60, VF 85 and VF 110.

DCLVF 35

Mounting principle

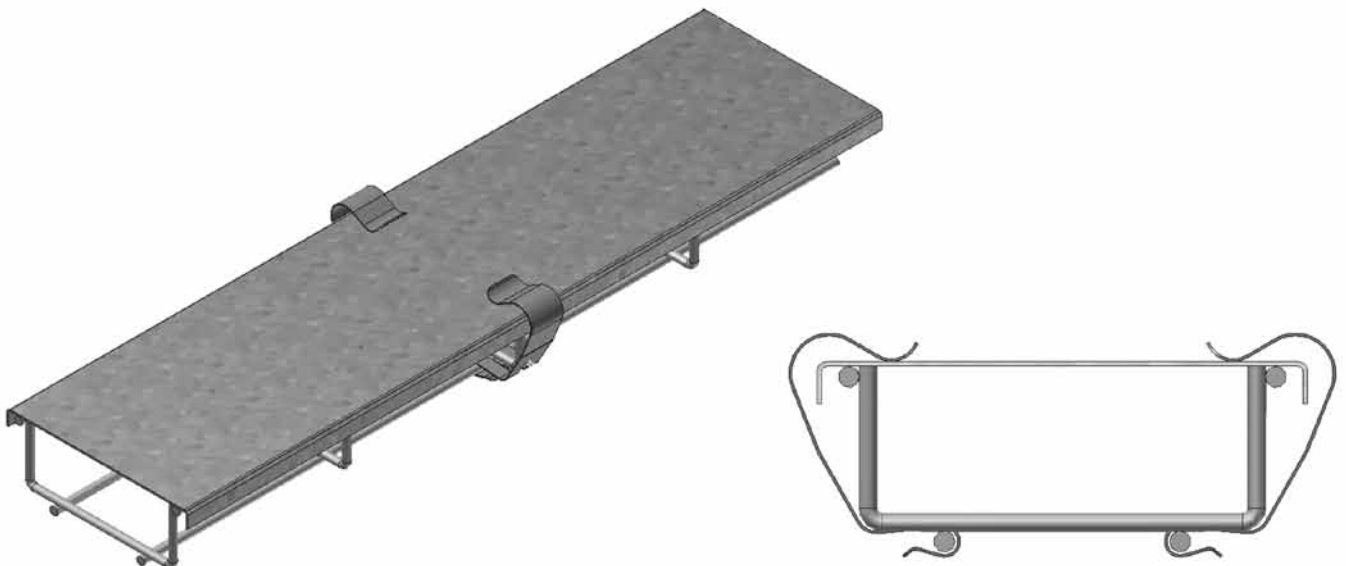

For VFL 35 and VF 35.

VFMM

Mounting principle

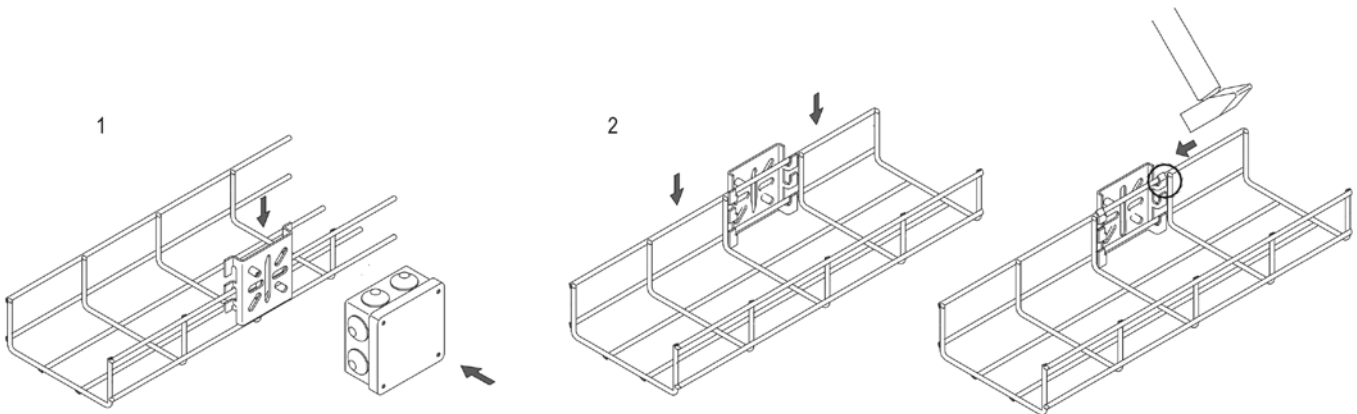

For fixation of contact boxes and wall fixation.
Can only be used with VFL 60 and VF 60.

VMB

Mounting principle

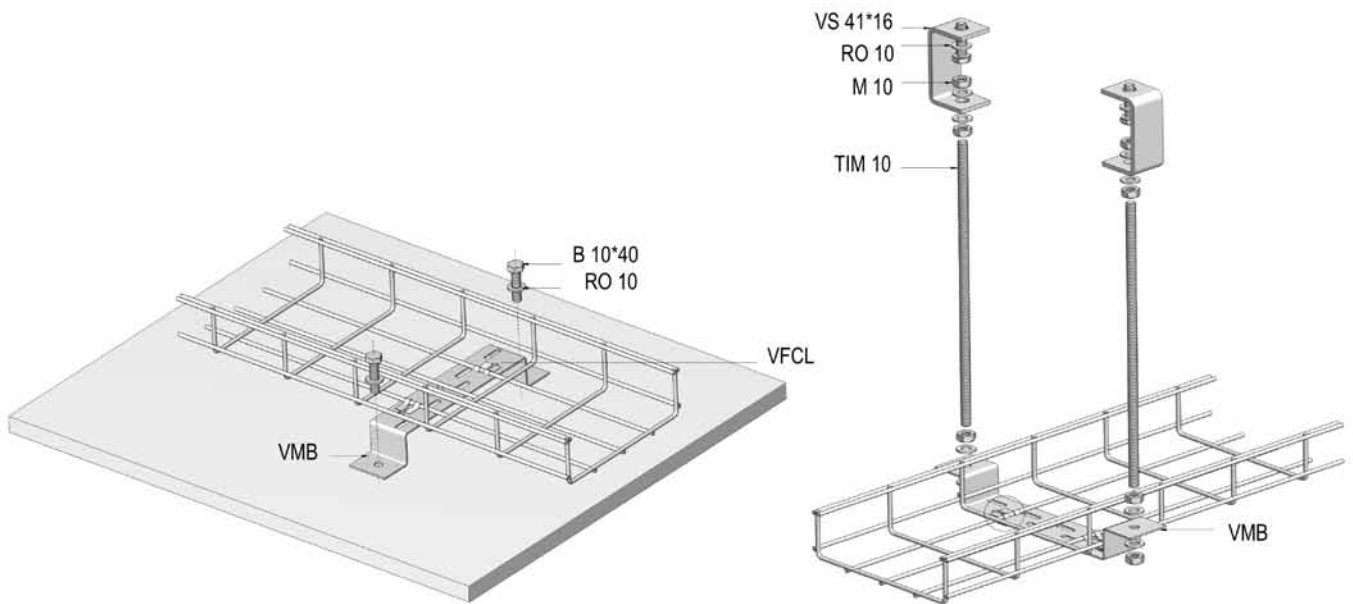

Suitable as floor-, wall-, and suspension bracket.
Floor bracket and suspension bracket : to mount with VFCL.
Wall bracket : to mount with VFK.

SLOS

Mounting principle

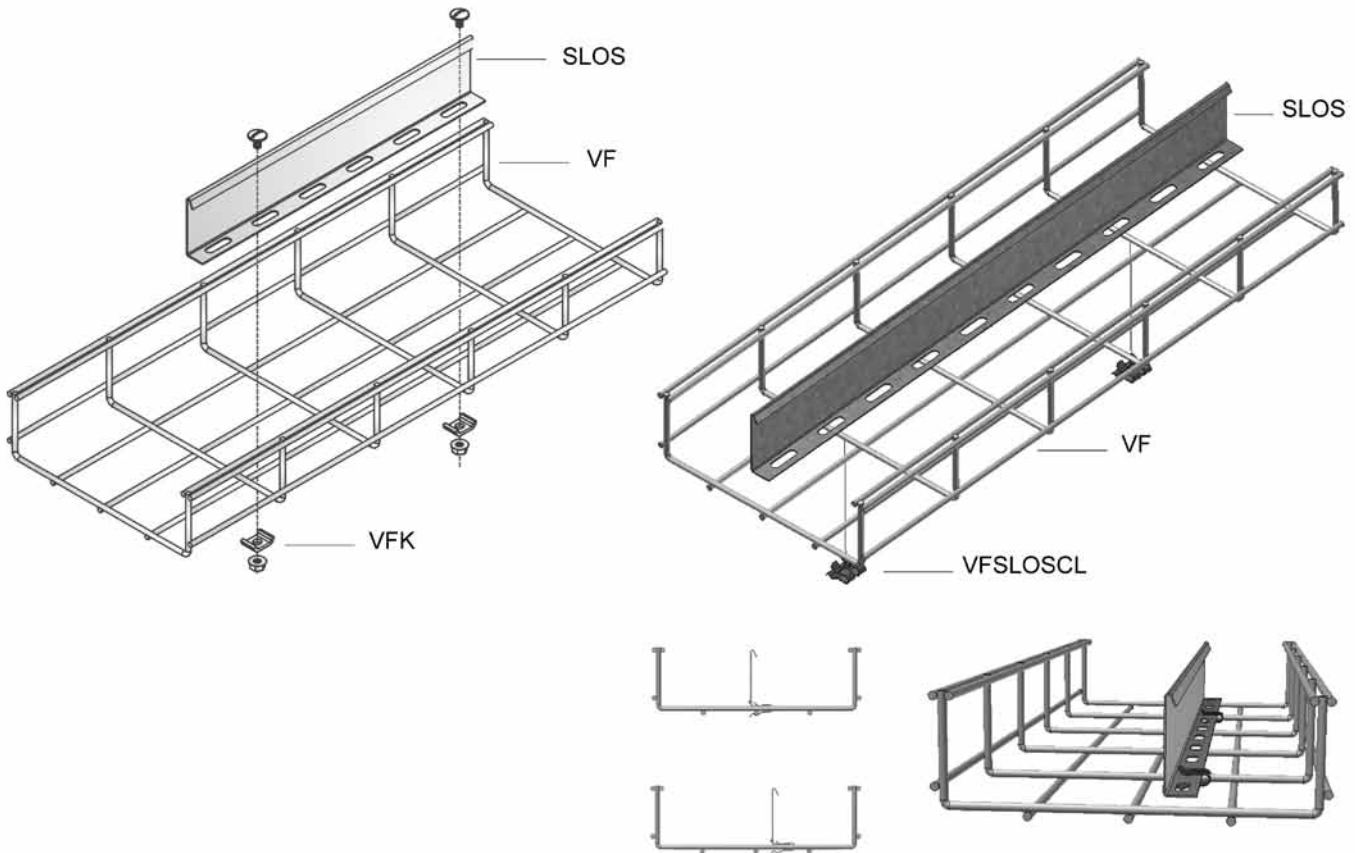

VFK

Mounting principle

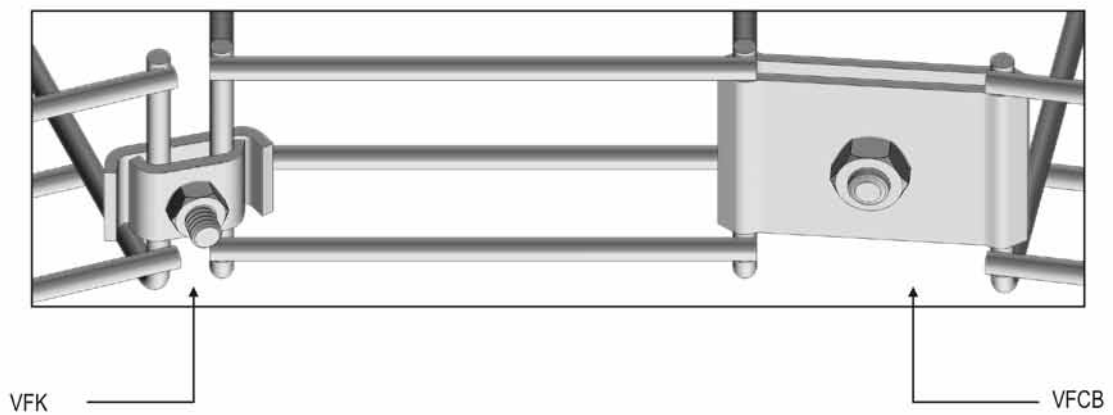

HOW TO CUT THE WIRE

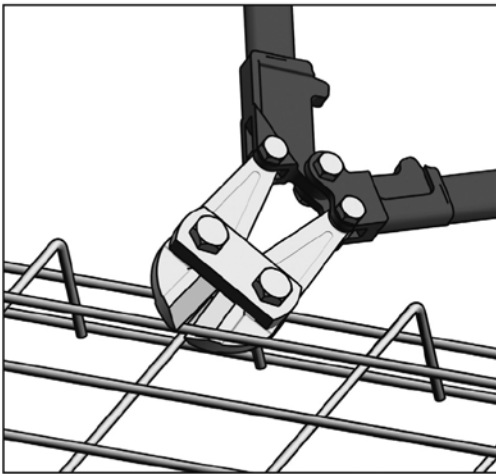

The shape of the cable basket can be changed to your requirements. For cutting of the wire mesh, we recommend the use of a professional set of cutting pliers with offset cut (drawing here below).
The cutting of the wire is by preference being done as close as possible to the crossing of the wires, in order to prevent cable damage.

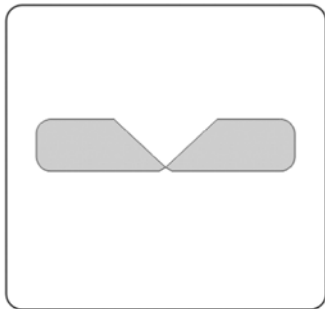

yes
Offset cut

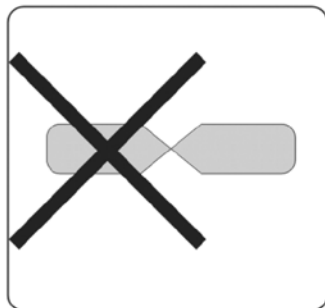

no
Central cut

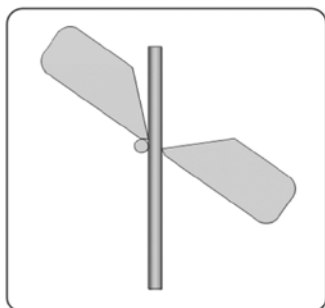

Placing of the clamping jaws

BEND WITH LARGE RADIUS

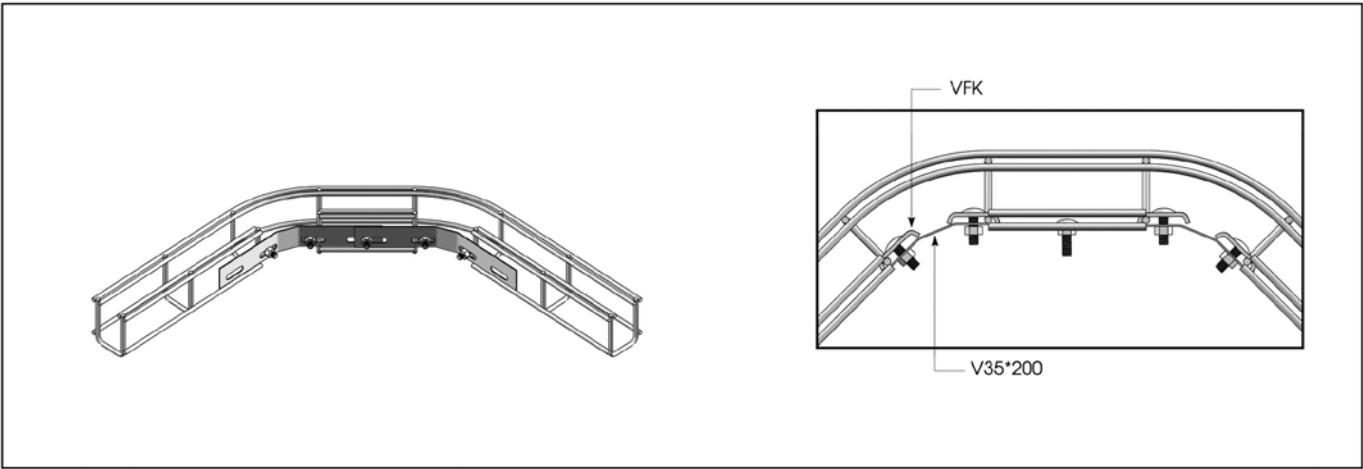

Widths 100 - 550

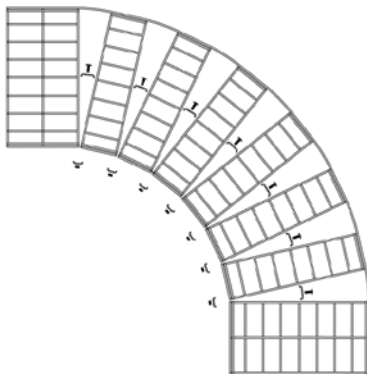
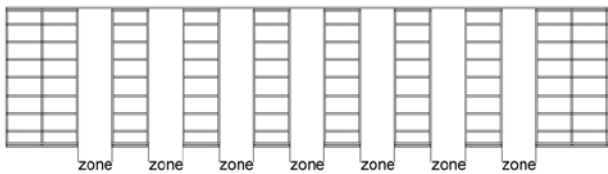
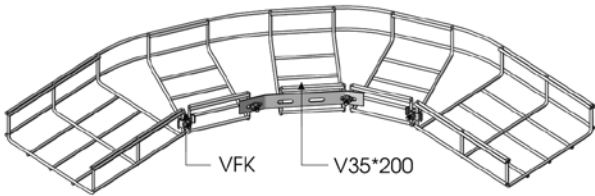

Width	Height	Zones	VFK	VFCB	V 35*200
100	35/60	3	2	2	1
150	35/60	3	4	-	1
200	35/60	4	4	-	1
250	35	5	6	-	1
300	60	5	5	-	-
350	35	6	6	-	-
400	60	7	7	-	-
450	35	8	8	-	-
500	60	9	9	-	-
550	35	10	10	-	-

Fixation possibilities

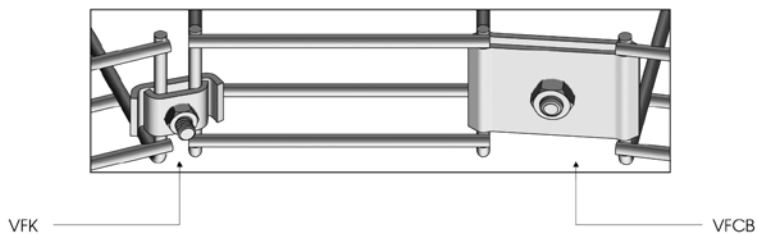

BEND WITH SMALL RADIUS

Method A

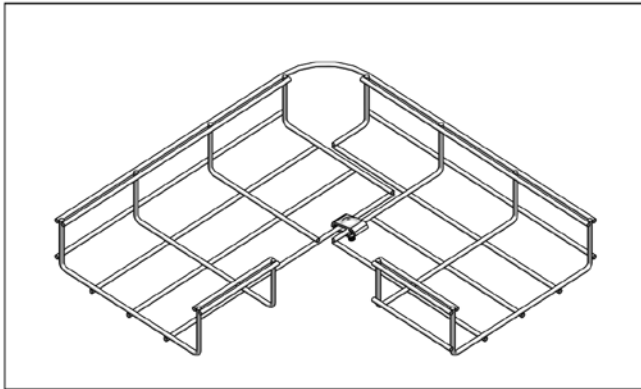

Method B

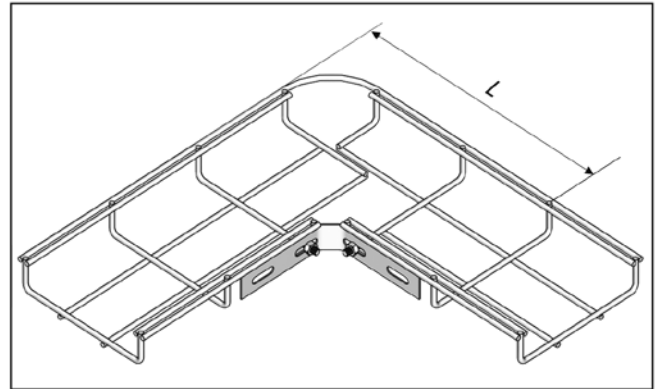

Width	Height	VFK	V 35*200	Zones	Mounted	Method	Length
100	35/60	2	1			B	269,5
150	35	2	1			B	269,5
150	60	2	1			B	269,5
200	35	1	0			B	369,5
200	60	1	0			A	369,5
250	35	2	1			B	369,5
300	60	2	0			A	469,5
350	35	2	1			B	469,5
400	60	2	0			A	569,5
450	35	2	1			B	569,5
500	60	3	0			A	669,5
550	35	2	1			B	669,5
600	60	4	0			A	679,5

To make a small radius bend, one has to take a length of cable basket and cut away the necessary zones out of the bottom and the side. Then bend the cable basket to an angle of 90° and connect both ends by means of method A or B as mentioned in the table above. For the cable basket, width 50, only a large radius can be made.

T-PIECE

Type Wire cable tray

Reference	Number of zones to cut away
VF(L) 60*100	2
VF(L) 60*150	3
VF 85*100	2
VF 85*250	4
VF 85*350	5
VF 85*450	6



Equal for all widths

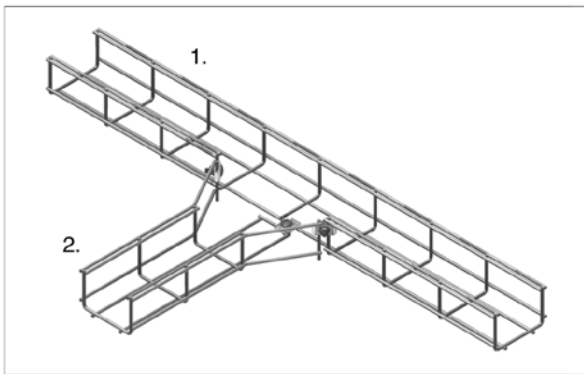
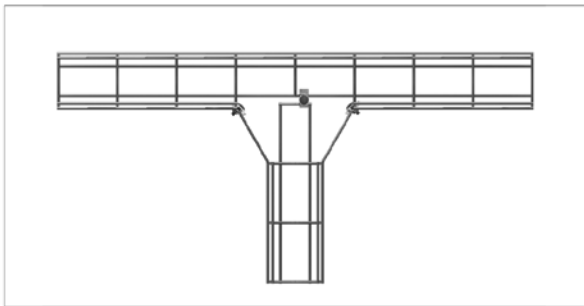
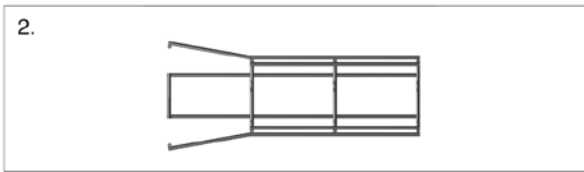

Type Wire cable tray

Reference	Number of zones to cut away
VF(L) 60*200	4
VF(L) 60*300	5
VF(L) 60*400	6
VF(L) 60*500	7
VF(L) 60*600	8
VF 85*150	3
VF 110*200	4
VF 110*300	5
VF 110*400	6

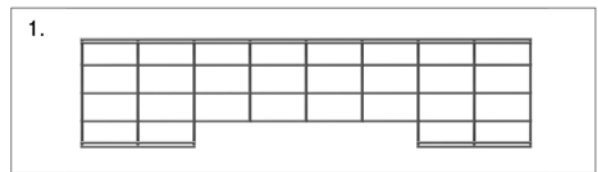

Equal for all widths

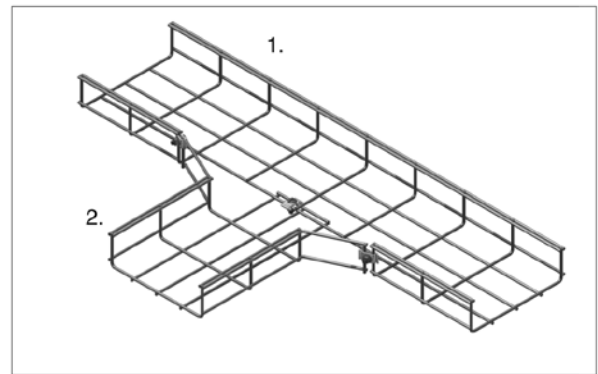
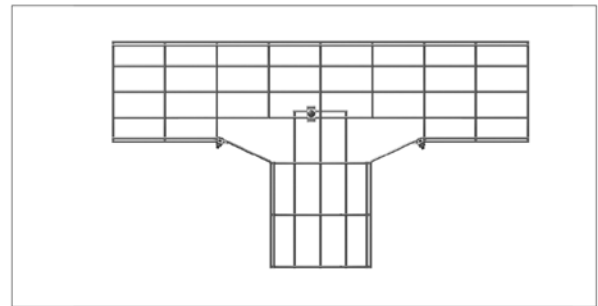
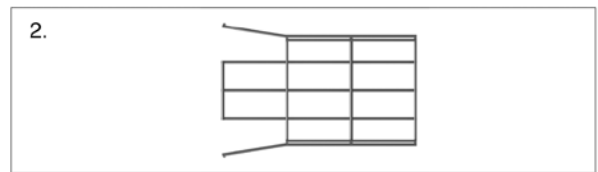

A T-piece is being made by cutting away the side of the basket tray (no 1), according to the data mentioned in the table above. Always the same zones will have to be cut away in basket tray (no 2). The remaining sides are being bend across each other. The basket trays are being coupled with VFK.

CROSS SECTION

Type Wire cable tray

Reference	Number of zones to cut away
VF(L) 60*100	2x 2
VF(L) 60*150	2x 3
VF 85*100	2x 2
VF 85*250	2x 4
VF 85*350	2x 5
VF 85*450	2x 6

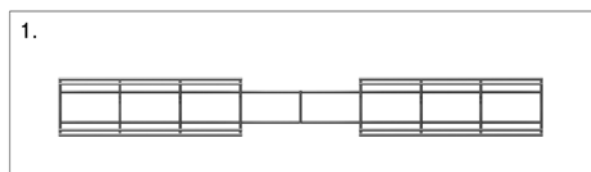

Equal for all widths

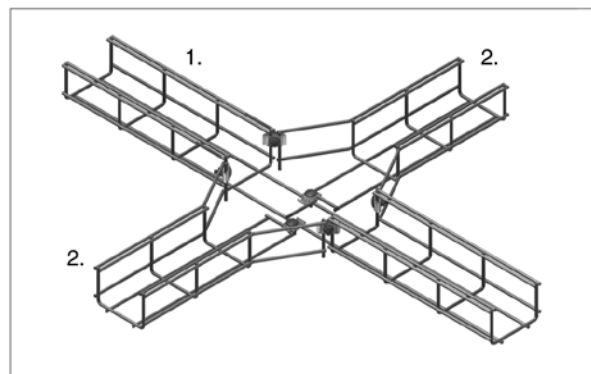
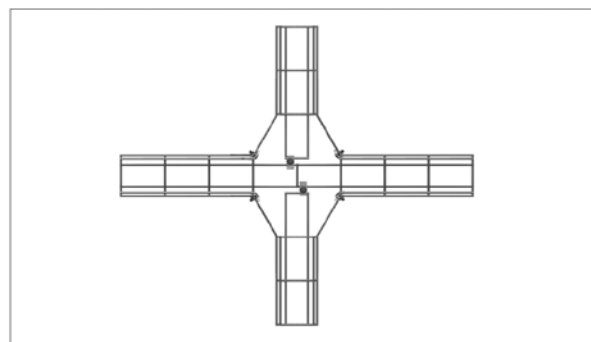
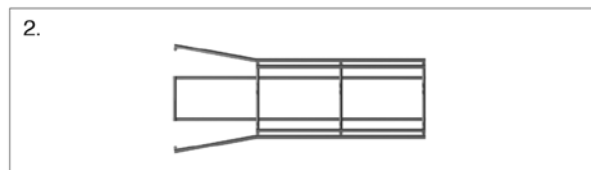

Type Wire cable tray

Reference	Number of zones to cut away
VF(L) 60*200	2x 4
VF(L) 60*300	2x 5
VF(L) 60*400	2x 6
VF(L) 60*500	2x 7
VF(L) 60*600	2x 8
VF 85*150	2x 3
VF 110*200	2x 4
VF 110*300	2x 5
VF 110*400	2x 6

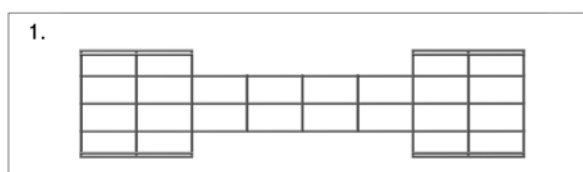

Equal for all widths

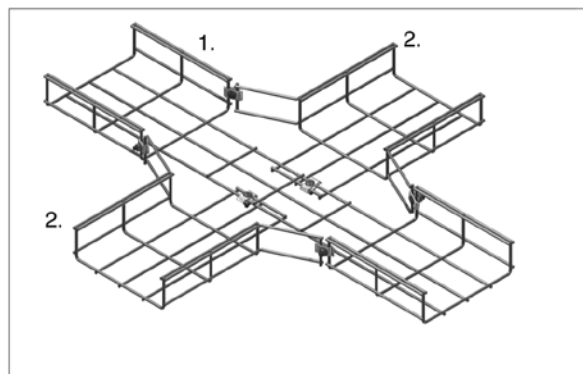
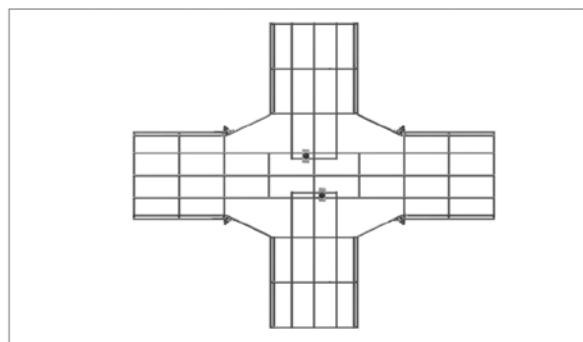
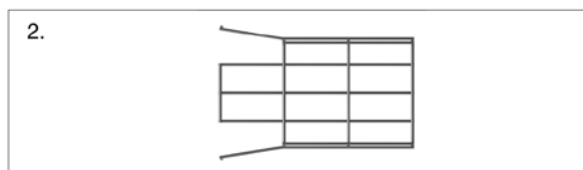

A cross-piece is being made by cutting away the side of the basket tray (no 1), according to the data mentioned in the table above. Always the same zones will have to be cut away in basket tray (no 2). The remaining sides are being bend across each other. The basket trays are being coupled with VFK.

LEVEL DIFFERENCES

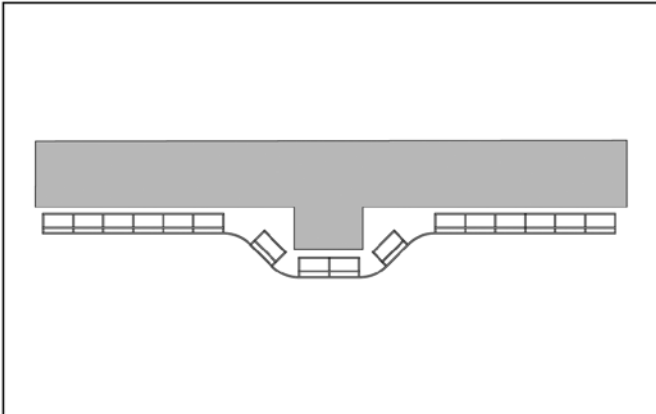

Any level difference can be obtained by cutting away the corresponding zone and bending the cable basket at that spot, until the required shape has been reached.
For extra reinforcement, the use of the connection plate V35*200 is being recommended.

Cutting and bending

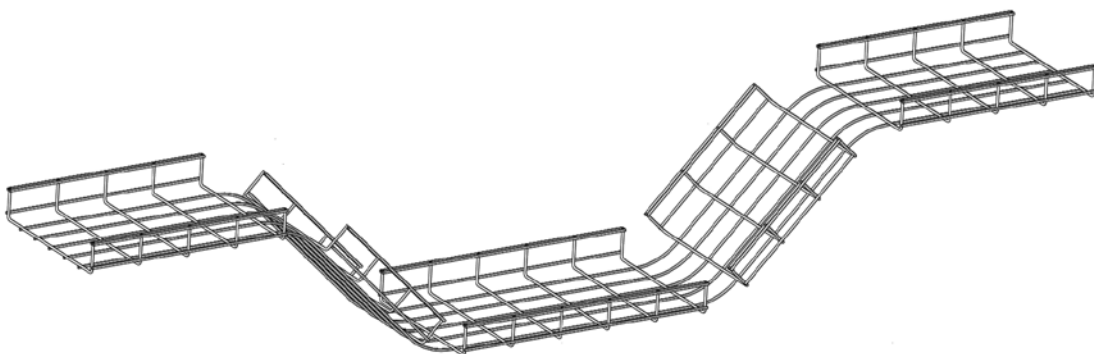
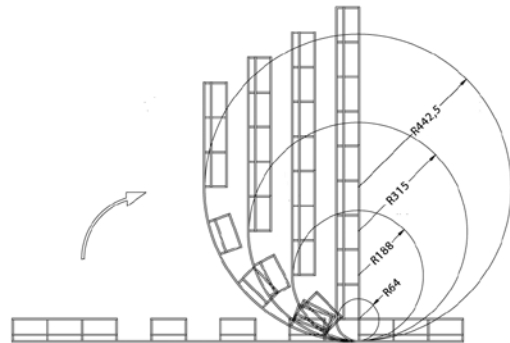
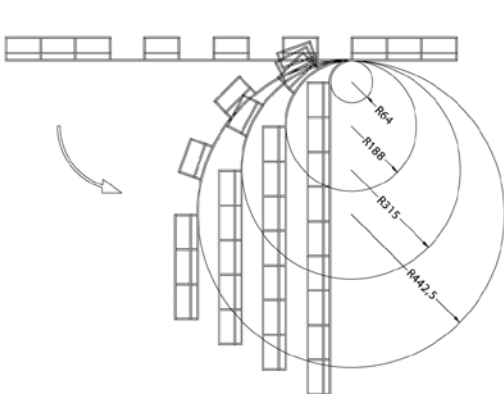

REDUCER

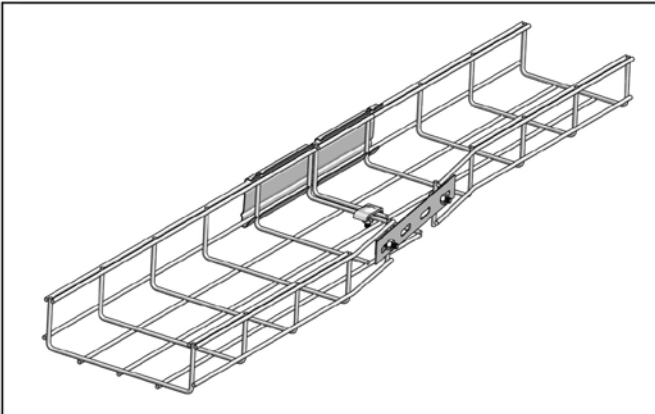

Cable basket can be reduced in order to connect them to a smaller section. All combinations are being based upon a few basic principles in order to obtain the required result.

1. Cut away the required zones from the bottom and the side.
2. Bend the side to the required width.
3. Connect the ends by means of KPVF, VFK and V 35*200

Difference of 50mm

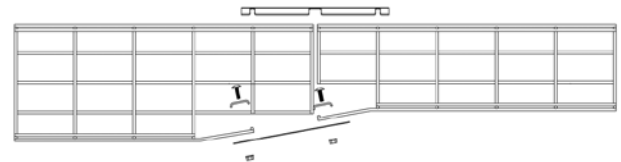
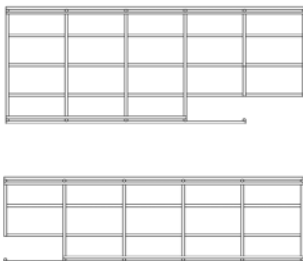

Difference of 100mm

