

optical



2013 - High Performance Portfolio

Optical & IC Selector Guide

- TIAs
- ROSAs
- Single-LANE CDRs
- Dual-Lane CDRs
- Multi-LANE Signal Conditioners
- Laser Drivers
- Limiting Amplifiers
- Transceiver ICs
- Optical & Copper Reference Design Kits

High-Speed Communications Products

SEMTECH
GENNUM PRODUCTS

contents

Overview	1
Semtech Solutions	3
Emerging Technology	4
Optical Applications	5
Copper Applications	6
<hr/>	
TIAs	7
ROSAs	9
Super High Gain ROSAs	10
Single-Lane CDRs	11
Dual-Lane CDRs	12
Multi-Lane Signal Conditioners	13
Laser Drivers and Limiting Amplifiers	14
Transceiver IC's	15
Optical Module Reference Design Kits	16
CDR-based Copper Cable Assembly Reference Design Kits	17
Portfolio Summary	18

High Performance Optical and Copper Products

Shipping more than 130 million Optical ICs, Semtech is an active contributor to networking standards development. This combination of real-world experience and industry leadership enables us to deliver the most complex solutions to our customers' designs.

Semtech designs the industry's most innovative optical, analog and mixed signal semiconductor solutions to serve the rising global demand for high-speed data transmission products—robust solutions that improve performance and reliability, simplify design, lower system costs and speed time-to-market.

Semtech offers one of the industry's most comprehensive portfolios of optical transceiver IC products ranging from 100Mb/s-100Gb/s supporting such key industry standards such as Fibre Channel, InfiniBand®, Ethernet, PON, SONET and PCI Express®.

For optical component suppliers, this highly differentiated set of products provides a unique roadmap that improves performance and reliability, simplifies design, lowers costs and speeds time-to-market.

For systems designers and manufacturers working on the next generation of high-speed networks, Semtech's multi-lane and multi-rate 10Gb/s-100Gb/s backplane solutions provide cost-effective, low power, high performance products to enable next-generation networks.



Enabling High Performance, High-Speed:

- Class leading IC solutions for 100G applications in CFP, CFP2/4 and QSFP modules
- Receive Optical Sub-Assembly (ROSA) based on Semtech's Rchip technology
- Full portfolio of integrated solutions to address all SFP+ and XFP modules
- Dual lane signal conditioners with integrated DML or EML driver
- Low power, reference-free CDRs
- Limiting amplifiers (LA) that provide wideband, low noise post-amplification
- Transimpedance amplifiers (TIAs) that exceed the IEEE 10GbE Stressed Receiver Sensitivity (SRS) specifications
- High performance, low power laser drivers
- Full portfolio of integrated solutions for all PON applications including complete reference designs
- Industry's first single-chip 10G PON transceivers for symmetric and asymmetric applications
- Industry's first quad 10 Gb/s CDR, enabling long reach Infiniband® QDR, 40 GbE and 100 GbE applications
- Protocol-independent repeaters/redrivers
- SFP+ reference design kits for optical module and copper cable assemblies to decrease design time

Building the Future Together

As networking requirements continue to evolve, so will we, working with customers to provide solutions for tomorrow's networking challenges. One thing that won't change, however, is Semtech's commitment to being a reliable partner and providing innovative approaches that deliver unrivaled performance for the most sophisticated applications.

Technology Leadership for the Future of Optical Communications

TECHNOLOGIES

CDRs

Market leader in CDRs

Reference-Free operation

Integrated solutions to address power requirements of emerging SFP+ SONET market

ROSAs

Best-in-class sensitivity, based on our patented Rchip technology

TIAs

Proven reliability, with over 44 million sold

LASER DRIVERS & LIMITING AMPS

Only integrated solution among industry leaders

MARKETS

100G ETHERNET

Class leading CDRs, TIAs and drivers

Solutions for CFP, CFP2/4 and QSFP

16G FIBRE CHANNEL

Industry's first complete integrated IC solution for 16G Fibre Channel

10G

Complete portfolio of module IC and backplane solutions

Solutions for XFP, SFP+, QSFP+

PON/FTTH

Industry's first fully integrated 10G PON solutions

Highly integrated chipset solutions for EPON & GPON ONU/OLT





Emerging Technology

25-28Gb/s Reference-Free CDRs

High Performance Reference-Free CDRs for Next-Generation 100Gb/s Networks

The GN2425 and GN2426 are high performance clock and data recovery (CDR) retimers designed to support the implementation of 100G Ethernet optical modules. They are designed to handle 25Gb/s data streams within next-generation 100Gb/s pluggable fiber-optic modules, line cards and direct-attach copper/optical cables.

FEATURES

- Enable OIF CEI-28G-VSR retimed interfaces by compensating for losses in the data transmission and resetting the jitter budget
- Optimized for best jitter performance
- Designed specifically for the next-generation 100GbE CFP2 module form-factor
- Enable higher module density and faster serial bit rates

APPLICATIONS

- 100Gb/s Ethernet linecards and fiber-optic modules
- 100Gb/s OTN linecards and fiber-optic module
- Infiniband™ EDR direct-attach cables

GN2425

Provides excellent output jitter performance for optimal interfacing to laser drivers, or directly driving over a copper cable.

GN2426

In the receive chain, the GN2426 removes jitter from the recovered optical signal, providing ample margin for line card receivers to recover the high-speed data stream from the module.

Part Number	GN2425	GN2426
Data Rate (Gb/s)	24.8 to 28.3	24.8 to 28.3
Input Stage	Equalizer	Limiting Amp

Optical Applications

Semtech products offer a comprehensive selection of optical transceiver ICs and components for all 10GbE and OC-192 module form factors, as well as copper solutions for high-speed serial line card and backplane communications.

10G XFP Module for $\leq 40\text{Km}$ Applications

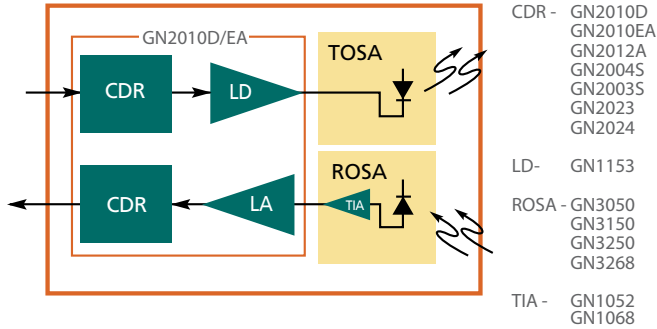

10G XFP Module for $\leq 80\text{Km}$ Applications

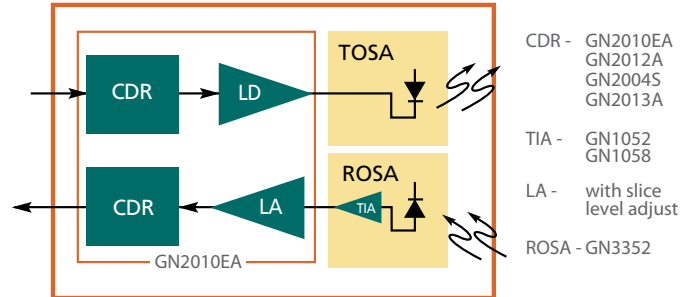

6/8/10G SFP+ Module Applications

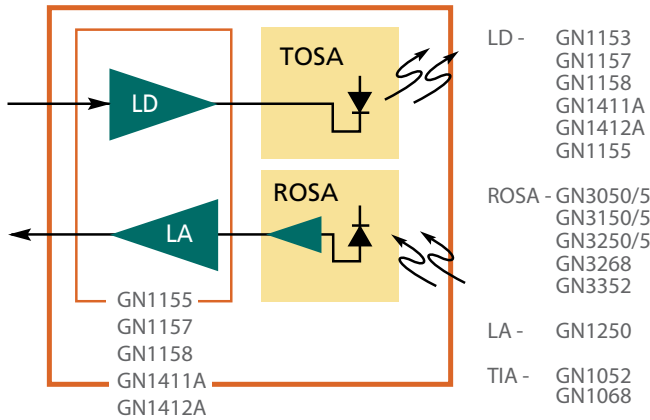

10G SFP+ LRM Module Applications

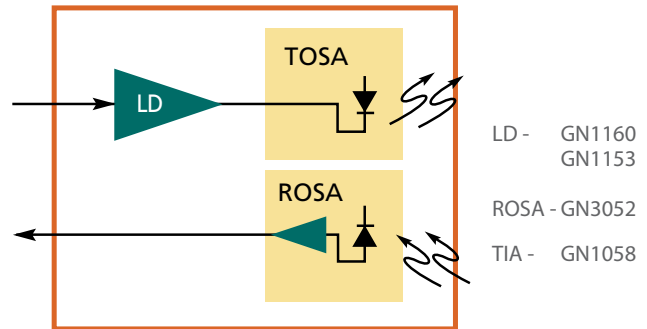

Lowest power, LA Free SFP+ Architecture

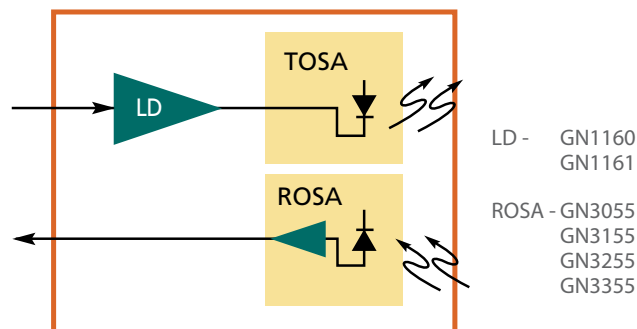

Copper Applications

Semtech products offer a comprehensive selection of optical transceiver ICs and components for all 10GbE and OC-192 module form factors, as well as copper solutions for high-speed serial line card and backplane communications.

High-Speed Backplanes

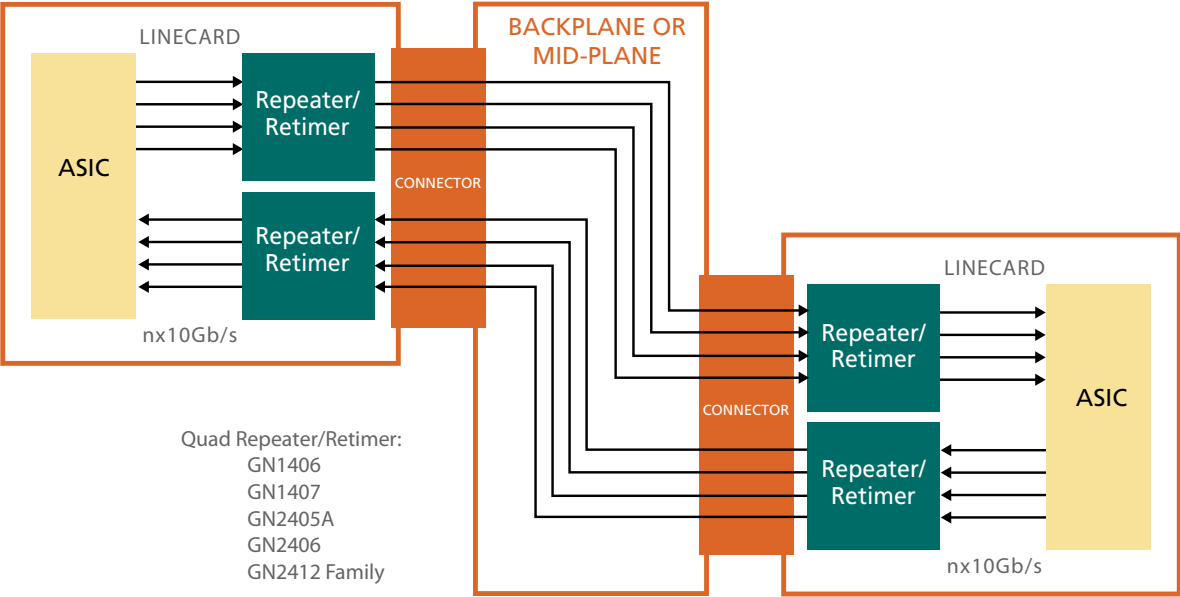

Redundancy Switching

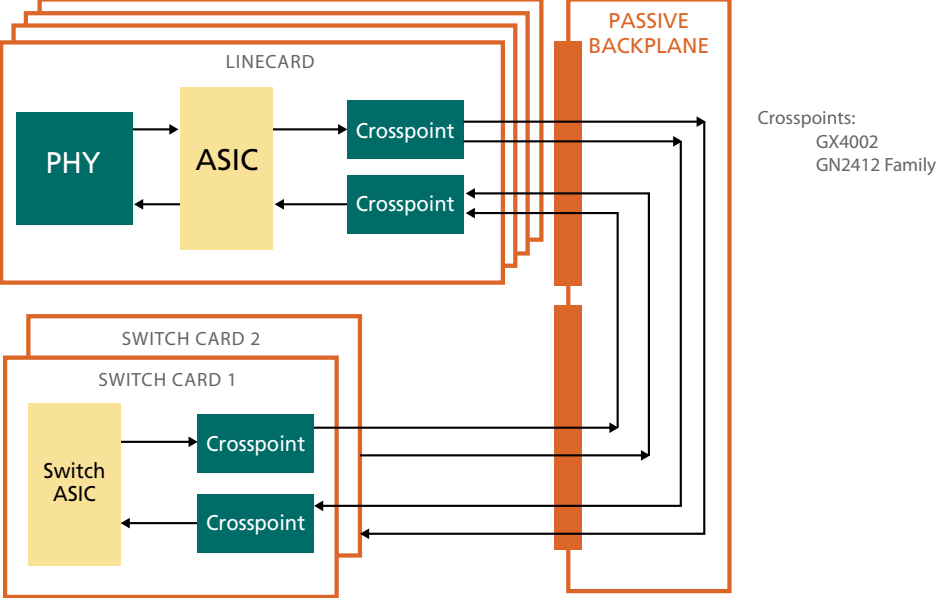

TIA

Wideband, low noise transimpedance amplifiers (TIAs) for your optical communication applications.

Semtech offers a portfolio of fully integrated Silicon Germanium (SiGe) BiCMOS and pure CMOS transimpedance amplifiers providing wideband, low noise pre-amplification of a current signal from a PIN photodiode or APD. Semtech's TIAs offer best-in-class performance in limiting, linear or automatic gain control versions for use in high performance optical receivers operating from 155 Mb/s to 28Gb/s.

FEATURES

- Wideband, low noise TIAs
- Limiting, linear and AGC versions
- Fully integrated on-chip de-coupling for low cost and best performance

APPLICATIONS

- ITU/IEEE-based transmission systems
- 10G and 100G Ethernet
- SONET/SDH based transmission systems, test equipment and optical modules from OC-3 to OC-192
- 8G and 16G Fibre Channel
- Serial data systems up to 28Gb/s
- PON/FTTH systems – BPON, EPON, GPON, 10GEPON and XG-PON
- 6G and 10G CPRI modules for wireless back haul
- 100GB/s Client side modules

NT20R67

Low cost 3.3V to 5.0V CMOS PIN TIA with automatic gain control and more than 43dB dynamic range for Optical Fiber applications up to 200Mb/s.

NT23L50

622Mb/s high sensitivity TIA for FTTH and Telecom Fiber transceiver applications.

NT24L50

1.25Gb/s high sensitivity TIA with automatic gain control for FTTH and datacom fiber transceiver applications.

NT24L55

Super high sensitivity, high performance CMOS 1.25 Gb/s TIA with 35dB of dynamic operating range designed for FTTH applications such as GePON transceivers and long haul telecom/datacom applications.

NT25L51

2.5 Gb/s CMOS TIA for FTTH and Telecom Fiber transceiver applications with automatic gain control enabling over 27 dB of dynamic operating range.

NT25L59

2.5 Gb/s high sensitivity CMOS TIA for GPON with automatic gain control enabling over 30 dB of dynamic operating range.

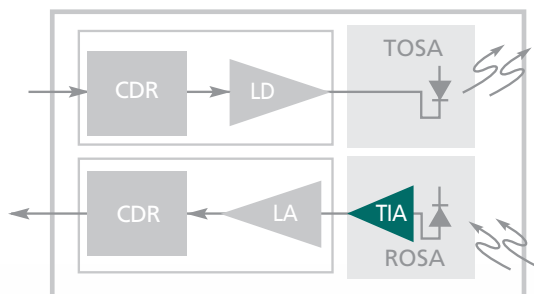

GN1056

Linear TIA for high performance APD applications such as ultra-long haul telecom and submarine applications.

GN1058

High gain TIA optimized for applications requiring AGC, such as 10GBASE-LRM and DWDM receivers for low OSNR environments.

GN7068

Limiting TIA designed for APD applications such as ROSAs for 10G PON OLT's and 10GBASE-ZR transceivers modules.

GN1068

Multi-rate limiting TIA providing high gain and wideband performance for use in Ethernet and emerging 16G Fibre Channel applications.

GN7050, GN7051, GN7052, GN7053

Limiting TIA's designed specifically for 1G EPON, 1G GPON, 2.5G XG-PON and 10G EPON OLT applications.

GN1083

4x28GB/s limiting TIA optimized for 100GBASE-LR4 applications.

TIAs							
Part Number	Overview	Data Rate (Gb/s)	Gain	BW (GHz)	Supply (V)	Noise	Applications
NT20R67	155 Mb/s AGC TIA	0.155	63k Ω	0.165	3.3/5.0	11 nA	OC-3, Fast Ethernet
NT23L50	622 Mb/s AGC TIA	0.622	50k Ω	0.32	3.3	60 nA	OC-12, BPON
NT24L50	1.25 Gb/s AGC TIA	1.25	25k Ω	0.75	3.3	92 nA	GbE, EPON
NT24L55	1.25 Gb/s High Sensitivity AGC TIA	1.25	46k Ω	0.75	3.3	74 nA	EPON
NT25L51	2.5 Gb/s AGC TIA	2.5	8k Ω	1.7	3.3	230 nA	OC-48, GPON (APD)
NT25L59	2.5 Gb/s High Sensitivity AGC TIA	2.5	29k Ω	1.5	3.3	108 nA	GPON (PD)
GN1056	10G Linear	to 11.3	500/1k Ω	12	+3.3	1 μ A	OC-192
GN1058	10G AGC	to 11.3	4k Ω	12	+3.3	1 μ A	10GBASE-LRM & DWDM
GN7068	10G Limiting	to 11.3	3k Ω	12	+3.3	1 μ A	APD ROSAs for 10G PON ONU & 10GBASE-ZR
GN1068	14G Limiting	to 14.3	6.75k Ω	12	+3.3	1.2 μ A	10GBASES-SR/LR/ER & 16G FC
GN7050	1.25G Burst mode Limiting	1.25	12k Ω	*	*	*	1G EPON OLT
GN7051	2.5G Burst mode Limiting	2.5	1.5k Ω	*	*	*	2.5G XG-PON OLT
GN7052	Tri-rate PON TIA	1.25/2.5 /10.3	2k Ω	*	*	*	1.25G EPON/ 2.5G XG-PON / 10G EPON OLT
GN7053	1G GPON Burst mode Limiting	1.25	1.25k Ω	*	*	*	1G GPON OLT
GN1083	Quad 25G Limiting	100	6.3k Ω	*	*	*	100GBASE-LR4

* Please contact your sales representative for a detailed datasheet.

ROSAs

Best-in-class receive optical sub-assemblies (ROSAs) based on patented Rchip technology.

Semtech's complete line of PIN and APD ROSA products spans 850 nanometer (nm) to 1550nm including limiting, linear and automatic gain control (AGC) functionality. Our PIN ROSAs operate at $+3.3V \pm 10\%$ and from $-40^{\circ}C$ to $+85^{\circ}C$, with highly accurate RSSI functionality and industry best dynamic range. The ROSA products feature patented Rchip packaged in a fully compliant SC or LC type optical subassembly and are available with optional flex circuits.

Super High Gain Rchip ROSAs deliver $35k\Omega$ of gain that eliminates the cost and power of the limiting amplifier for SFP+ applications.

FEATURES:

- Best-in-class stressed receiver sensitivity
- High gain to ensure exceptional crosstalk performance within the module
- Patented Rchip technology to ensure maximum module manufacturing yield
- Super High Gain deliver most integrated, lowest power SFP+ solution

APPLICATIONS:

- 10GBASE-LR
- 10GBASE-ER
- 10GBASE-LRM
- OC-192 SR-1
- OC-192 IR-2
- 10G EPON
- 80 km
- DWDM
- 8GFC & 10GFC

GN3150

850nm limiting ROSA is ideal for 10GBASE-SR and 8G Fibre Channel applications.

GN3050

10 km limiting ROSA provides excellent performance achieving $-21dBm$ unstressed sensitivity. Ideal for 10GBASELR and SR-1.

GN3250

10/40 km XMD compatible limiting ROSA provides excellent $-21dBm$ unstressed sensitivity and high ORL for 10GBASE-ER and IR-2 applications.

GN3052

AGC ROSA for 10 GbE LRM and linear applications. Interoperability with all leading EDC solutions for LRM.

GN3352

10G APD ROSA with AGC TIA is ideal for both 80km limiting and DWDM applications requiring excellent OSNR performance.

GN3268

10/40 km XMD compatible low power (94 mW) limiting ROSA

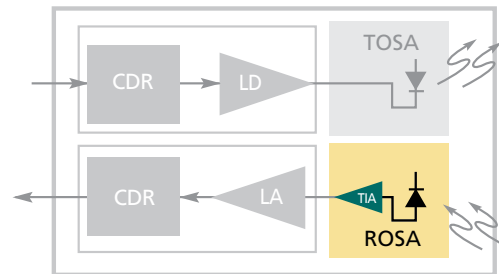

GN3352
ROSA



GN3250
ROSA

Semtech's Super High Gain ROSAs

Best-in-class receive optical sub-assemblies (ROSAs) based on patented Rchip technology.

Super High Gain ROSAs deliver 300mV module output swing allowing for new SFP+ architecture. 125mW total power dissipation achieving approximately 100mW power savings over traditional architecture.

GN3155

Super High Gain 850nm limiting ROSA is ideal for 10GBASE-SR and 8G Fibre Channel applications.

GN3055

Super High Gain 10 km limiting ROSA provides excellent performance achieving -21dBm unstressed sensitivity. Ideal for 10GBASELR and SR-1.

GN3255

Super High Gain 10/40 km XMD compatible limiting ROSA provides excellent -21dBm unstressed sensitivity and high ORL for 10GBASE-ER and IR-2 applications.

GN3355

High Gain APD limiting ROSA optimized for TDM application provides best in class sensitivity and crosstalk.

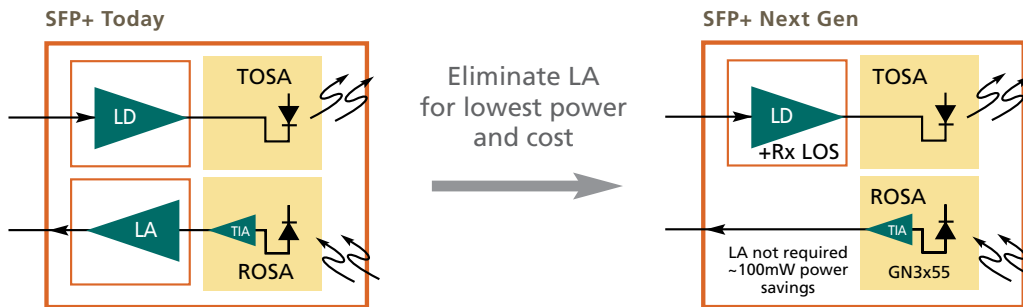

ROSAs & SUPER HIGH GAIN ROSAs								
Part Number	Overview	Data Rate (Gb/s)	Gain	Supply	RSSI	Unstressed Sensitivity	Stressed Sensitivity	ORL
GN3150	SR Rchip Limiting	to 11.3	10kΩ	+3.3V ± 10%	Yes	-15dBm OMA	-13.5dBm OMA (BASE-SR)	-14dB
GN3050	10km Rchip Limiting	to 11.3	10kΩ	+3.3V ± 10%	Yes	-21dBm	-16.8dBm OMA (BASE-L)	-14dB
GN3250	40km Rchip Limiting	to 11.3	10kΩ	+3.3V ± 10%	Yes	-21dBm	-16.0dBm OMA (BASE-E)	-27dB
GN3052	LRM Rchip AGC	to 11.3	9kΩ	+3.3V ± 10%	Yes	-17dBm OMA	-12dBm OMA (LRM Symmetric, 6" FR4)	-14dB
GN3352	APD with AGC	to 11.3	4kΩ	+3.3V ± 10%	VAPD	-27dBm	-	-27dB
GN3055	10km Super High Gain Rchip	to 11.3	35kΩ	+3.3V ± 10%	-	-21dBm	Eliminate LA in SFP+	-14dB
GN3155	SR Super High Gain Rchip	to 11.3	35kΩ	+3.3V ± 10%	Yes	-15dBm OMA	Eliminate LA in SFP+	-14dB
GN3255	40km Super High Gain Rchip	to 11.3	35kΩ	+3.3V ± 10%	Yes	-21dBm	Eliminate LA in SFP+	-27dB
GN3355	High Gain APD Rchip	to 11.3	13kΩ	+3.3V ± 10%	Yes	-27dBm	Eliminate LA in SFP+	-27dB
GN3068	10km Low Power Limiting	to 11.3	7kΩ	+3.3V ± 10%	Yes	-21dBm	94 mW power dissipation	-14dB
GN3268	40km Low Power Limiting	to 11.3	7kΩ	+3.3V ± 10%	Yes	-21dBm	94mW power dissipation	-27dB

Single-Lane CDRs

Semtech's clock and data recovery (CDR) products offer the highest performance in the key areas of power consumption, receiver sensitivity, output jitter and jitter tolerance.

LOW POWER

Delivering low power single lane 10Gb/s CDR products enables small form factor module designs.

PIN COMPATIBILITY

With pin compatible solutions for 10GbE, SONET OC-192 and 8G, 10G and 16G Fibre Channel, overall design effort is reduced.

REFERENCE FREE

Reference-free CDRs ease the requirements at both the module and system level.

LEADING JITTER PERFORMANCE

With industry leading input jitter tolerance and output jitter, Semtech's CDRs help create an extremely robust design.

XFP AND SFP+ COMPATIBLE

Semtech's CDRs are fully XFP compliant. The low power, reference-free architecture also enables the use of CDRs in SFP+ modules.

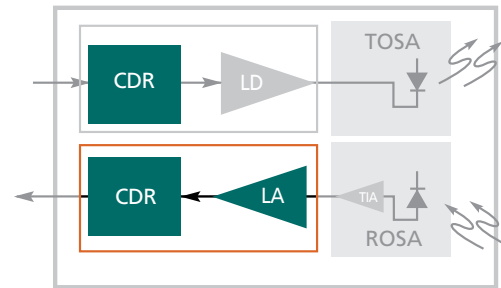

SINGLE-LANE CDRS

Part Number	Data Rate (Gb/s)	Input Stage	Laser Driver	Slice Level Adjust	Loopback Support	Pin Compatibility	Supply (V)	Pkg	Applications
GN2003S	9.95 - 11.3	Limiting Amplifier	-	-	Yes	GN1113 GN2023	3.3	24 QFN	OC-192, 10GbE, 10GFC
GN2004S	9.95 - 11.3	Equalizer	-	-	Yes	GN2024	3.3	24 QFN	OC-192, 10GbE, 10GFC
GN2013A	9.95 - 11.3	Limiting Amplifier	-	Yes	Yes	-	3.3	24 QFN	OC-192, 10GbE, 10GFC
GN2014A	9.95 - 11.3	Equalizer	-	-	Yes	GN1114	3.3	24 QFN	10GbE, 10GFC
GN2023	9.95 - 11.3	Limiting Amplifier	-	-	Yes	GN1113 GN2003S	3.3	24 QFN	10GbE, 10GFC
GN2024	9.95 - 11.3	Equalizer	-	-	Yes	GN2004S	3.3	24 QFN	10GbE, 10GFC

Dual-Lane CDRs

Semtech’s dual-lane signal conditioners, with integrated VCSEL, DML or EML driver, offer the lowest power, smallest footprint solution for XFP and retimed SFP+ modules.

ENABLING SFP+ SONET

The GN2010D and GN2010EA enable a SONET compliant module in an SFP+ form factor. The integration of the laser driver enables a low power solution for SFP+. The high level of integration also delivers a small footprint solution to fit within the form factor. The 3.3V, reference clock free architecture simplifies the overall module design and saves cost.

FEATURE SET FOR DWDM APPLICATIONS

The GN2010/12 family has a rich feature set to enable optimal performance in DWDM applications. The features include slice level adjust, programmable peaking on the receive path input and sampling clock phase adjust.

LOW COST, SMALL FOOTPRINT SOLUTION

By integrating the limiting amplifier, laser driver and receive and transmit CDR, the GN2010D, GN2010EA and GN2017A provide an optimal path for lower cost designs. The integrated APC loop and small number of external components also save cost. The high level of integration in a small, 5mmx5mm 32-QFN package enables use in very high density designs.

MULTI-RATE SUPPORT

The GN2010/12 family supports multiple data rates and standards in a single device. The device is able to retimed data at 8.5Gb/s for 8G Fibre Channel and is able to retimed anywhere from 9.95Gb/s to 11.7Gb/s to support standards such as 10GbE and OC-192 SONET.

The GN2017A supports 9.95 - 11.3 Gb/s and 14.025 Gb/s data rates enabling retimed, converged SFP+ modules for 16G FC and 10G FCoE applications.

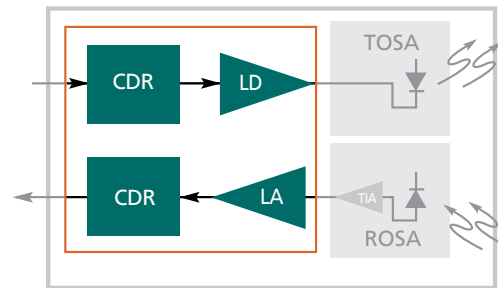

DUAL-LANE CDRS								
Part Number	Data Rate (Gb/s)	Lanes	Laser Driver	Slice Level Adjust	Pin Compatibility	Supply (V)	Pkg	Applications
GN2010D	8.5 9.95-11.7	2 (1 Rx + 1 Tx)	DML	Yes	GN2010EA	3.3	32 QFN	XFP and SFP+ 10GbE, OC-192 and 8GFC
GN2010EA	8.5 9.95-11.7	2 (1 Rx + 1 Tx)	EML	Yes	GN2010D	3.3	32 QFN	XFP and SFP+ 10GbE, OC-192, 8GFC and DWDM
GN2012A	8.5 9.95-11.7	2 (1 Rx + 1 Tx)	-	Yes	-	3.3	32 QFN	XFP and SFP+ 10GbE, OC-192, 8GFC and DWDM
GN2017A	9.95-11.7 14.025	2 (1 Rx + 1 Tx)	VCSEL	No	GN2010X	3.3	32 QFN	16G FC, 10G FCoE

Backplane & Linecard Signal Conditioners

Semtech's multi-channel signal conditioners enhance the reach and robustness of high-speed serial links by compensating for transmission losses and re-setting the crosstalk and jitter budgets.

HIGH LEVEL OF INTEGRATION AND SMALL FOOTPRINT

Semtech's backplane & linecard signal conditioners are ideal for small form factor modules or dense backplane /linecard applications.

FULL PORTFOLIO

Semtech products offer solutions for Ethernet, Infiniband®, Fibre Channel® and PCI Express®. Solutions are available with and without CDR functionality.

DRIVE LONG BACKPLANES OR CABLES

A combination of Equalizer, DFE and CDR technology allows for an optimal solution to drive long, dense backplanes or cables at high speeds.

LOW POWER

Semtech's 5 Gb/s and higher CDR products require the lowest power in the industry, a key factor as densities increase.

RESET THE JITTER AND CROSSTALK BUDGETS

Using CDRs will reset the jitter budget, substantially increasing the robustness of the system and allowing for design flexibility. Using CDRs in multi-channel systems will also reset the crosstalk budget, an increasing concern at higher data rates.

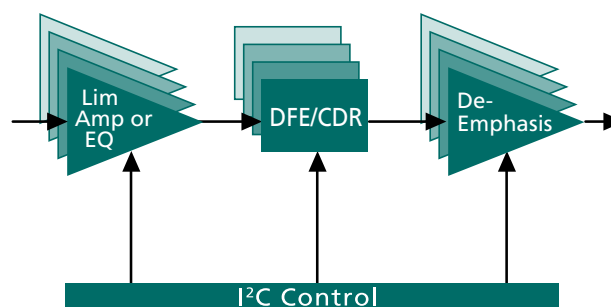

MULTI-LANE SIGNAL CONDITIONERS										
Part Number	Data Rate (Gb/s)	Lanes	CDR	Ref Clock	Input Stage	De-emphasis	Pin Compatibility	Supply (V)	Pkg	Applications
GN1406	2.5 3.125 5.0, 6.25	4	Yes	Required	Equalizer (Programmable)	Yes	GN1407	1.2 1.8	56 QFN	PCIe Gen 1/2, SNAP-12, POP-4/LX-4/CX-4/KX-4, XAUI/RXAUI and Rapid I/O
GN1407	1 - 8	4	-	N/A	Equalizer (Programmable)	-	GN1406	1.2 1.8	56 QFN	PCIe Gen 1/2/3, SNAP-12, POP-4/LX-4/CX-4/KX-4, XAUI/RXAUI and Rapid I/O
GN2405A	9.95 - 11.3	4	Yes	Not Required	Equalizer	Yes	GN2406	3.3	48 QFN	10GbE, 40GbE, 100GbE Infiniband®, QDR
GN2406	9.95 - 11.3	4	Yes	Not Required	Limiting Amp	Yes	GN2405A	3.3	48 QFN	10GbE, 40GbE, 100GbE Infiniband®, QDR
GX4002	9.95 - 11.3, 14.025	2	Yes	Not Required	Equalizer	Yes	-	3.3	32 QFN	10GbE, 40GbE, 100GbE 16G Fibre Channel
GN2412 Family	1.25 - 12.8	12	Yes	Required	Adaptive Equalizer +5-tap DFE	Yes	-	0.9 1.8	144 BGA	10GbE, 40GbE, 100GbE, Infiniband®, QDR, CPRI

Laser Drivers and Limiting Amplifiers

High performance laser drivers and limiting amplifiers for optical communication.

APPLICATIONS:

- 10G EPON, XG-PON1 and XG-PON2
- 8G Fibre Channel
- 9.95 Gb/s OC-192 and 10.70 Gb/s OC-192 with FEC
- 10.3 Gb/s Ethernet
- 10.52 Gb/s Fibre Channel
- 11.1 Gb/s Ethernet over SONET
- 11.3 Gb/s Fibre Channel with Forward Error Correction
- 40G QSFP+ modules

LASER DRIVERS:

NT20042

Low cost 3.3V / 5.0 V 300 Mb/s LED driver for SONET, ESCON and Fast Ethernet applications over optical fiber.

NT22L33

3.3 V/ 5.0 V CMOS laser driver for data rates of 125 Mb/s to 1.25 Gb/s.

GN1153B & GN1153C

These low power DFB/FP laser drivers are designed specifically to address the 1W power requirements of SFP+, while still satisfying the requirements for XENPAK, X2, and XFP.

GN1160 & GN1161

Very low power laser drivers for DFB/VCSEL applications. RSSI feature for compatibility with our high gain ROSA's, enabling SFP+ modules without limiting amplifiers.

LIMITING AMPLIFIERS:

NT20045

Low cost 3.0 V to 5.5 V, 200 Mb/s limiting amplifier for SONET, SDH, ESCON and Fast Ethernet applications over optical fiber.

NT24L71

1.25 Gb/s CMOS 3.0 V to 5.5 V limiting amplifier with CML data outputs and signal status output in QSOP 16.

NT24L73

1.25 Gb/s CMOS limiting amplifier with CML data outputs and signal status in an MSOP package.

GN1250L

A limiting amplifier that provides wideband, low noise postamplification, aimed primarily at OC-192 and SDH STM-64 systems.

LASER DRIVERS						
Part Number	Overview	Data Rate (Gb/s)	Max Mod / Bias Current	Supply	Pkg.	Applications
NT20042	300 Mb/s LED Driver	0.3	100mA	3.3/5.0V	QSOP 16	OC-3, Fast Ethernet
NT22L33	1.25 Gb/s FP/DFB Laser Driver	1.25	70mA / 80mA	3.3/5.0V	4mm QFN24	OC-3, OC-12, GbE
GN1153B/C	DFB/FP Laser Driver	to 11.3	80mA / 120mA	3.3V (opt. 5V output stage)	24 QFN	10GbE, OC-192
GN1160	DFB driver	to 11.3	90mA/ 120mA	3.3V (Opt. 2.9V)	28 QFN	10GE SFP+ 10GBASE-LR
GN1161	VCSEL driver	to 11.3	20mA/ 15mA	3.3V (Opt. 2.9V)	28 QFN	10GE SFP+ 10GBASE-SR

LIMITING AMPLIFIERS							
Part Number	Overview	Data Rate (Gb/s)	Gain	BW	Supply	Noise Figure	Applications
NT20045	200 Mb/s Limiting Amp	0.2	60dB	0.125	3.3/5.0V	80uV	OC-3, Fast Ethernet
NT24L71	1.25 Gb/s Limiting Amp	1.25	46dB	0.938	3.3V	300uV	OC-3, OC-12, GbE
NT24L73	1.25 Gb/s Limiting Amp	1.25	46dB	0.938	3.3V	300uV	OC-3, OC-12, GbE
GN1250L	10/14G Limiting Amp	to 14.5	33.7dB	14.7GHz	+3.3V	13dB	10GbE, OC-192, 8G and 16GFC

Transceiver IC's (LD & LA)

High performance laser drivers and limiting amplifiers for optical communication.

NT25L91

2.5 Gb/s CMOS burst mode laser driver and limiting post amplifier with digital set-up, control, on-chip NVM and APD DAC output.

NT28L90

Combined 10 Gb/s limiting post amplifier and 2.5 Gb/s burst mode laser driver for cost critical 10GEPON and XG-PON asymmetric applications. The NT28L90 features Tx & Rx sleep control, TX_SD output and Tx Power burst monitoring.

GN7354 & GN7355

10G EPON transceiver for next generation PON systems. The GN7355 combines a 10G burst mode laser driver with a receive CDR and is targeted at 10G EPON symmetric applications. The GN7354 is a pin-for-pin compatible, de-rated version of the GN7355 intended to address the 1.25Gb/s and 2.5Gb/s transmit data rate, and cost pressures of the 10Gb/s asymmetric EPON and XG-PON applications.

GN1411A/12A

The GN1411A/GN1412A are highly-integrated, low-power, small footprint transceivers that are ideal for SFP+ LR/ER optical modules.

GN1157/58

Semtech's latest, lowest power transceiver IC's for SFP+ LR/SR applications with integrated APC and advanced eye shaping features.

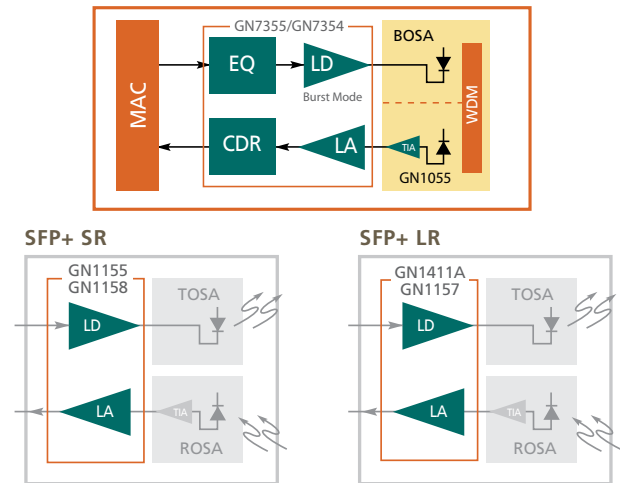

TRANSCEIVER IC (LD&LA)						
Part Number	Overview	Data Rate (Gb/s)	Max Mod / Bias Current	Supply	Pkg.	Applications
NT25L91	2.5 Gb/s Burst Mode LDD & LA	2.5	90mA / 100mA	3.3V	4mm QFN28	EPON, GPON, BOSA-on-Board
NT28L90	10 Gb/s Burst Mode LDD & LA	Rx 10.3 Tx 2.5	90mA / 100mA	3.3V	4mm QFN28	10GEPON, XG-PON1 (Asymmetric)
GN7354	Burst Mode DFB + Receive LA & CDR	Rx: 10.3 Tx: to 2.5	90mA / 90mA	3.3V (3.3 V or 5V output stage)	32 QFN	10GEPON, XG-PON (Asymmetric)
GN7355	Burst Mode DFB + Receive LA & CDR	10.3	90mA / 90mA	3.3V +5 V output stage (optional 3.3 V)	32 QFN	10GEPON, XG-PON (Symmetric)
GN1155	VCSEL Driver + Receive LA	to 11.3	15mA / 12mA	3.3V	24 QFN	8GFC, 10GbE, and SFP+
GN1411A	DFB/FB Laser Driver + Receive LA	to 11.3G	80mA / 120mA	3.3V	32 QFN	10GbE, OC-192
GN1412A	EML Laser Driver + Receive LA	to 11.3G	2.5Vpp / 120mA	3.3V	32 QFN	10GbE, OC-192
GN1157	DML Laser Driver + Receive LA	to 11.3G	90mA / 120mA	3.3V	28 QFN	10GbE LR SFP+
GN1158	VCSEL Laser Driver + Receive LA	to 11.3G	20mA / 15mA	3.3V	28 QFN	10GbE SR SFP+

Optical Module Reference Design Kit

Improve the performance and time to market of your SFP+ design with Semtech Optical Module Reference Design Kits.

FAST TIME TO MARKET

Semtech's reference design kits include schematics, layout files and a design guide as well as attentive support from experienced applications engineers. This reduces both design costs and decreases time to market. This is further realized in the FTTx market where it is possible to re-use the 10G symmetric SFP+ design to address the 10G asymmetric market.

GN1157 RDK (RDK-SFP+-Optical02)



GN1160/GN3055 RDK (RDK-SFP+-Optical04)



BROAD RANGE OF REFERENCE DESIGNS AVAILABLE

Reference design kits are offered to cover a wide variety of SFP+ applications, including symmetrical and asymmetrical PON, and 10GbE SR and LR applications.

For ethernet SFP+, designs are available for both the traditional architecture (including a limiting amplifier in the receive chain), as well as a new LA-free architecture enabled by Semtech's High Gain ROSA portfolio.

GN7354/7355 RDK RDK-SFP+-PON-S00 RDK-SFP+-PON-A00



Rx CDR+ Tx Burst Mode
DML driver
GN7355 - Symmetric PON
GN7354 - Asymmetric PON

RDK-SFP++LR

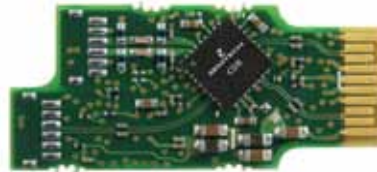

OPTICAL REFERENCE DESIGN KITS

Part Number	Parts Demonstrated	Data Rate (Gb/s)	Connector Type	Wavelength (nm)	Applications
RDK-SFP++LR	GN3068/GN3268, GN2010D/GN2042	1/11.3	SFP+	1310	10GbE LR, OC-192
RDK-SFP++ER	GN3268, GN2010EA /GN2044	1/11.3	SFP+	1550	10GbE ER, OC-192
RDK-SFP+-PON-S00	GN7355	10.3	SFP+	1577/ 1270	10G EPON
RDK-SFP+-PON-A00	GN7354	10/1.25 10/2.5	SFP+	1577/1310 1577/ 1270	10G EPON Asym. XG-PON1
RDK-SFP+-Optical02	GN1157	1/11.3	SFP+	1310	10GbE LR
RDK-SFP+-Optical03	GN1158	1/11.3	SFP+	850	10GbE SR
RDK-SFP+-Optical04	GN1160 & GN3055	1/11.3	SFP+	1310	10GbE LR
RDK-SFP+-Optical05	GN1161 & GN3155	1/11.3	SFP+	850	10GbE SR

CDR-based Copper Cable Assembly Reference Design Kits

SFP+ copper cable assembly reference design kits (RDK) based on Semtech's industry leading 8 Gb/s and 10 Gb/s CDR technology.

FAST TIME TO MARKET

Semtech's reference design kits include schematics, layout files and a design guide as well as attentive support from experienced applications engineers. This reduces both design costs and time, to get to market quickly.

MULTIPLE EVALUATION OPTIONS

The RDKs are available in two forms, with or without attached cable. The version with attached cable can be immediately plugged into a system or test set up for quick evaluation. The version without attached cable comes as a set of two populated PCBs with housing, wherein any manufacturer's cable can be soldered onto the PCBs for a custom evaluation.

CDR ADVANTAGE

There are multiple advantages to a CDR-based copper cable assembly. By resetting the jitter budget in the connector, the cable's performance will be independent of the system it is plugged into. It allows for longer trace lengths and reduces overall crosstalk in the system.

Copper Cable Assembly RDK



COPPER REFERENCE DESIGN KITS						
Part Number	Data Rate (Gb/s)	Connector Type	Length (m)	Cable Gauge (AWG)	Full Action/ Half Action	Applications
RDK-SFP+-Copper00	8.5	SFP+	8	30	Full	8GFC
RDK-SFP+-Copper01	8.5	SFP+	15	24	Full	8GFC
RDK-SFP+-Copper02	10.3	SFP+	12	24	Full	10GbE, 10GFC
RDK-SFP+-Copper03	10.3	SFP+	7	30	Full	10GbE, 10GFC
RDK-SFP+-Copper04*	8.5	SFP+	N/A	N/A	Full	8GFC
RDK-SFP+-Copper05*	10.3	SFP+	N/A	N/A	Full	10GbE, 10GFC
RDK-QSFP-Copper00	40	QSFP	13	26	Full	10GbE, 40GbE, Infiniband® QDR
RDK-QSFP-Copper05	40	QSFP	13	26	Half	10GbE, 40GbE, Infiniband® QDR

*A version of the Reference Design Kit is available that contains two populated PCBs without housing, but no cable. It can be used to solder cable to the boards, if a cable type other than the one provided with the reference design kit is desired.

Portfolio Summary

TIAs							
Part Number	Overview	Data Rate (Gb/s)	Gain	BW (GHz)	Supply (V)	Noise	Applications
NT20R67	155 Mb/s AGC TIA	0.155	63kΩ	0.165	3.3/5.0	11 nA	OC-3, Fast Ethernet
NT23L50	622 Mb/s AGC TIA	0.622	50kΩ	0.32	3.3	60 nA	OC-12, BPON
NT24L50	1.25 Gb/s AGC TIA	1.25	25kΩ	0.75	3.3	92 nA	GbE, EPON
NT24L55	1.25 Gb/s High Sensitivity AGC TIA	1.25	46kΩ	0.75	3.3	74 nA	EPON
NT25L51	2.5 Gb/s AGC TIA	2.5	8kΩ	1.7	3.3	230 nA	OC-48, GPON (APD)
NT25L59	2.5 Gb/s High Sensitivity AGC TIA	2.5	29kΩ	1.5	3.3	108 nA	GPON (PD)
GN1056	10G Linear	to 11.3	500/1kΩ	12	+3.3	1μA	OC-192
GN1058	10G AGC	to 11.3	4kΩ	12	+3.3	1μA	10GBASE-LRM & DWDM
GN7068	10G Limiting	to 11.3	3kΩ	12	+3.3	1μA	APD ROSAs for 10G PON ONU & 10GBASE-ZR
GN1068	14G Limiting	to 14.3	6.75kΩ	12	+3.3	1.2μA	10GBASE-SR/LR/ER & 16G FC
GN7050	1.25G Burst mode Limiting	1.25	12kΩ	*	*	*	1G EPON OLT
GN7051	2.5G Burst mode Limiting	2.5	1.5kΩ	*	*	*	2.5G XG-PON OLT
GN7052	Tri-rate PON TIA	1.25/2.5/10.3	2kΩ	*	*	*	1.25G EPON/2.5G XG-PON/10G EPON OLT
GN7053	1G GPON Burst mode Limiting	1.25	1.25kΩ	*	*	*	1G GPON OLT
GN1083	Quad 25G Limiting	100	6.3kΩ	*	*	*	100GBASE-LR4

* Please contact your sales representative for a detailed datasheet.

ROSAs & SUPER HIGH GAIN ROSAs								
Part Number	Overview	Data Rate (Gb/s)	Gain	Supply	RSSI	Unstressed Sensitivity	Stressed Sensitivity	ORL
GN3150	SR Rchip Limiting	to 11.3	10kΩ	+3.3V ± 10%	Yes	-15dBm OMA	-13.5dBm OMA (BASE-SR)	-14dB
GN3050	10km Rchip Limiting	to 11.3	10kΩ	+3.3V ± 10%	Yes	-21dBm	-16.8dBm OMA (BASE-L)	-14dB
GN3250	40km Rchip Limiting	to 11.3	10kΩ	+3.3V ± 10%	Yes	-21dBm	-16.0dBm OMA (BASE-E)	-27dB
GN3052	LRM Rchip AGC	to 11.3	9kΩ	+3.3V ± 10%	Yes	-17dBm OMA	-12dBm OMA (LRM Symmetric, 6" FR4)	-14dB
GN3352	APD with AGC	to 11.3	4kΩ	+3.3V ± 10%	VAPD	-27dBm	-	-27dB
GN3055	10km Super High Gain Rchip	to 11.3	35kΩ	+3.3V ± 10%	-	-21dBm	Eliminate LA in SFP+	-14dB
GN3155	SR Super High Gain Rchip	to 11.3	35kΩ	+3.3V ± 10%	Yes	-15dBm OMA	Eliminate LA in SFP+	-14dB
GN3255	40km Super High Gain Rchip	to 11.3	35kΩ	+3.3V ± 10%	Yes	-21dBm	Eliminate LA in SFP+	-27dB
GN3355	High Gain APD Rchip	to 11.3	13kΩ	+3.3V ± 10%	Yes	-27dBm	Eliminate LA in SFP+	-27dB
GN3068	10km Low Power Limiting	to 11.3	7kΩ	+3.3V ± 10%	Yes	-21dBm	94 mW power dissipation	-14dB
GN3268	40km Low Power Limiting	to 11.3	7kΩ	+3.3V ± 10%	Yes	-21dBm	94mW power dissipation	-27dB

SINGLE-LANE CDRS									
Part Number	Data Rate (Gb/s)	Input Stage	Laser Driver	Slice Level Adjust	Loopback Support	Pin Compatibility	Supply (V)	Pkg	Applications
GN2003S	9.95 - 11.3	Limiting Amplifier	-	-	Yes	GN1113 GN2023	3.3	24 QFN	OC-192, 10GbE, 10GFC
GN2004S	9.95 - 11.3	Equalizer	-	-	Yes	GN2024	3.3	24 QFN	OC-192, 10GbE, 10GFC
GN2013A	9.95 - 11.3	Limiting Amplifier	-	Yes	Yes	-	3.3	24 QFN	OC-192, 10GbE, 10GFC
GN2014A	9.95 - 11.3	Equalizer	-	-	Yes	GN1114	3.3	24 QFN	10GbE, 10GFC
GN2023	9.95 - 11.3	Limiting Amplifier	-	-	Yes	GN1113 GN2003S	3.3	24 QFN	10GbE, 10GFC
GN2024	9.95 - 11.3	Equalizer	-	-	Yes	GN2004S	3.3	24 QFN	10GbE, 10GFC

DUAL-LANE CDRS									
Part Number	Data Rate (Gb/s)	Lanes	Laser Driver	Slice Level Adjust	Pin Compatibility	Supply (V)	Pkg	Applications	
GN2010D	8.5 9.95-11.7	2 (1 Rx + 1 Tx)	DML	Yes	GN2010EA	3.3	32 QFN	XFP and SFP+ 10GbE, OC-192 and 8GFC	
GN2010EA	8.5 9.95-11.7	2 (1 Rx + 1 Tx)	EML	Yes	GN2010D	3.3	32 QFN	XFP and SFP+ 10GbE, OC-192, 8GFC and DWDM	
GN2012A	8.5 9.95-11.7	2 (1 Rx + 1 Tx)	-	Yes	-	3.3	32 QFN	XFP and SFP+ 10GbE, OC-192, 8GFC and DWDM	
GN2017A	9.95-11.7 14.025	2 (1 Rx + 1 Tx)	VCSEL	No	GN2010X	3.3	32 QFN	16G FC, 10G FCoE	

MULTI-LANE SIGNAL CONDITIONERS										
Part Number	Data Rate (Gb/s)	Lanes	CDR	Ref Clock	Input Stage	De-emphasis	Pin Compatibility	Supply (V)	Pkg	Applications
GN1406	2.5 3.125 5.0, 6.25	4	Yes	Required	Equalizer (Programmable)	Yes	GN1407	1.2 1.8	56 QFN	PCIe Gen 1/2, SNAP-12, POP-4/LX-4/CX-4/KX-4, XAUI/RXAUI and Rapid I/O
GN1407	1 - 8	4	-	N/A	Equalizer (Programmable)	-	GN1406	1.2 1.8	56 QFN	PCIe Gen 1/2/3, SNAP-12, POP-4/LX-4/CX-4/KX-4, XAUI/RXAUI and Rapid I/O
GN2405A	9.95 - 11.3	4	Yes	Not Required	Equalizer	Yes	GN2406	3.3	48 QFN	10GbE, 40GbE, 100GbE Infiniband®, QDR
GN2406	9.95 - 11.3	4	Yes	Not Required	Limiting Amp	Yes	GN2405A	3.3	48 QFN	10GbE, 40GbE, 100GbE Infiniband®, QDR
GX4002	9.95 - 11.3, 14.025	2	Yes	Not Required	Equalizer	Yes	-	3.3	32 QFN	10GbE, 40GbE, 100GbE 16G Fibre Channel
GN2412 Family	1.25 - 12.8	12	Yes	Required	Adaptive Equalizer +5-tap DFE	Yes	-	0.9 1.8	144 BGA	10GbE, 40GbE, 100GbE, Infiniband®, QDR, CPRI

LASER DRIVERS						
Part Number	Overview	Data Rate (Gb/s)	Max Mod / Bias Current	Supply	Pkg.	Applications
NT20042	300 Mb/s LED Driver	0.3	100mA	3.3/5.0V	QSOP 16	OC-3, Fast Ethernet
NT22L33	1.25 Gb/s FP/DFB Laser Driver	1.25	70mA / 80mA	3.3/5.0V	4mm QFN24	OC-3, OC-12, GbE
GN1153B/C	DFB/FP Laser Driver	to 11.3	80mA / 120mA	3.3V (opt. 5V output stage)	24 QFN	10GbE, OC-192
GN1160	DFB driver	to 11.3	90mA/ 120mA	3.3V (Opt. 2.9V)	28 QFN	10GE SFP+ 10GBASE-LR
GN1161	VCSEL driver	to 11.3	20mA/ 15mA	3.3V (Opt. 2.9V)	28 QFN	10GE SFP+ 10GBASE-SR

LIMITING AMPLIFIERS							
Part Number	Overview	Data Rate (Gb/s)	Gain	BW	Supply	Noise Figure	Applications
NT20045	200 Mb/s Limiting Amp	0.2	60dB	0.125	3.3/5.0V	80uV	OC-3, Fast Ethernet
NT24L71	1.25 Gb/s Limiting Amp	1.25	46dB	0.938	3.3V	300uV	OC-3, OC-12, GbE
NT24L73	1.25 Gb/s Limiting Amp	1.25	46dB	0.938	3.3V	300uV	OC-3, OC-12, GbE
GN1250L	10/14G Limiting Amp	to 14.5	33.7dB	14.7GHz	+3.3V	13dB	10GbE, OC-192, 8G and 16GFC

TRANSCIEVER IC (LD&LA)						
Part Number	Overview	Data Rate (Gb/s)	Max Mod / Bias Current	Supply	Pkg.	Applications
NT25L91	2.5 Gb/s Burst Mode LDD & LA	2.5	90mA / 100mA	3.3V	4mm QFN28	EPON, GPON, BOSA-on-Board
NT28L90	10 Gb/s Burst Mode LDD & LA	Rx 10.3 Tx 2.5	90mA / 100mA	3.3V	4mm QFN28	10GEPON, XG-PON1 (Asymmetric)
GN7354	Burst Mode DFB + Receive LA & CDR	Rx: 10.3 Tx: to 2.5	90mA / 90mA	3.3V (3.3 V or 5V output stage)	32 QFN	10GEPON, XG-PON (Asymmetric)
GN7355	Burst Mode DFB + Receive LA & CDR	10.3	90mA / 90mA	3.3V + 5 V output stage (optional 3.3 V)	32 QFN	10GEPON, XG-PON (Symmetric)
GN1155	VCSEL Driver + Receive LA	to 11.3	15mA / 12mA	3.3V	24 QFN	8GFC, 10GbE, and SFP+
GN1411A	DFB/FB Laser Driver + Receive LA	to 11.3G	80mA / 120mA	3.3V	32 QFN	10GbE, OC-192
GN1412A	EML Laser Driver + Receive LA	to 11.3G	2.5Vpp / 120mA	3.3V	32 QFN	10GbE, OC-192
GN1157	DML Laser Driver + Receive LA	to 11.3G	90mA / 120mA	3.3V	28 QFN	10GbE LR SFP+
GN1158	VCSEL Laser Driver + Receive LA	to 11.3G	20mA / 15mA	3.3V	28 QFN	10GbE SR SFP+

OPTICAL REFERENCE DESIGN KITS

Part Number	Parts Demonstrated	Data Rate (Gb/s)	Connector Type	Wavelength (nm)	Applications
RDK-SFP++LR	GN3068/GN3268, GN2010D/GN2042	1/11.3	SFP+	1310	10GbE LR, OC-192
RDK-SFP++ER	GN3268, GN2010EA /GN2044	1/11.3	SFP+	1550	10GbE ER, OC-192
RDK-SFP+-PON-S00	GN7355	10.3	SFP+	1577/ 1270	10G EPON
RDK-SFP+-PON-A00	GN7354	10/1.25 10/2.5	SFP+	1577/1310 1577/ 1270	10G EPON Asym. XG-PON1
RDK-SFP+-Optical02	GN1157	1/11.3	SFP+	1310	10GbE LR
RDK-SFP+-Optical03	GN1158	1/11.3	SFP+	850	10GbE SR
RDK-SFP+-Optical04	GN1160 & GN3055	1/11.3	SFP+	1310	10GbE LR
RDK-SFP+-Optical05	GN1161 & GN3155	1/11.3	SFP+	850	10GbE SR

COPPER REFERENCE DESIGN KITS

Part Number	Data Rate (Gb/s)	Connector Type	Length (m)	Cable Gauge (AWG)	Full Action/ Half Action	Applications
RDK-SFP+-Copper00	8.5	SFP+	8	30	Full	8GFC
RDK-SFP+-Copper01	8.5	SFP+	15	24	Full	8GFC
RDK-SFP+-Copper02	10.3	SFP+	12	24	Full	10GbE, 10GFC
RDK-SFP+-Copper03	10.3	SFP+	7	30	Full	10GbE, 10GFC
RDK-SFP+-Copper04*	8.5	SFP+	N/A	N/A	Full	8GFC
RDK-SFP+-Copper05*	10.3	SFP+	N/A	N/A	Full	10GbE, 10GFC
RDK-QSFP-Copper00	40	QSFP	13	26	Full	10GbE, 40GbE, Infiniband® QDR
RDK-QSFP-Copper05	40	QSFP	13	26	Half	10GbE, 40GbE, Infiniband® QDR

* Please see Copper RDK page for explanation

Semtech's Optical & IC

for High-Speed Communications

Delivering some of the world's highest performing optical module and backplane IC solutions up to 100Gb/s, we enable Fiber optic capacity to move from the core of the network right to the home.



www.semtech.com/optical/



ABOUT SEMTECH

Semtech Corporation is a leading supplier of analog and mixed-signal semiconductor platforms for high-end consumer, computing, communications and industrial applications.

Our vision is to be the global leader in analog and mixed-signal platforms enabling architectural and performance differentiation. Semtech, publicly traded since 1967, is listed on the NASDAQ Global Select Market under the symbol SMTC and has more than 31 sales and application support offices in 18 countries as well as representatives and distribution support locations in more than 30 countries.

Our proprietary platforms, differentiated by innovation, size, efficiency, performance and reach, are used in some of the most innovative systems and products in the market today. Semtech products can be found in a wide range of fast-growing market segments, including Smart Phones, LED TVs, Tablets, Wireless LAN Modems, Automated Meter Reading, Ultra-Low-Power Medical, Satellite Communication, Cellular Infrastructure, Optical Transport, Datacenters and state-of-the-art Broadcast Video industries.

More than 5,000 customers worldwide rely on our diverse product portfolio and world class technology roadmap to provide them with solutions for low-power wireless communications, optical data transport, video broadcasting, power management, circuit protection, touch sensing, and more, making Semtech one of the most balanced semiconductor companies in the industry.

CUSTOMER CONTACT & SALES OFFICE LISTING

CORPORATE HEADQUARTERS

Camarillo, California
805 498 2111

NORTH AMERICA

Burlington, Ontario
905 632 2996

EUROPE

Wil, Switzerland
+ 41 71 313 4828

Bristol, England
+44 1454 462200

Courtaboeuf, France
+ 33 169 28 22 00

Hallbergmoos, Germany
+ 49 811 998 728 10

ASIA

Seoul, Korea
+ 82 2 527 4377

Tokyo, Japan
+ 81 3 5719 7560

Osaka, Japan
+ 81 6 6347 6570

Beijing, China
+ 86 10 6410 6855

Shanghai, China
+ 86 21 6391 0830

Shenzhen, China
Design Center &
Applications
+ 86 755 8282 8515

Taipei, Taiwan
+ 886 2 2748 3380

For a detailed list of sales representatives for your area please visit



www.semtech.com/contact



www.semtech.com



Semtech Corporation Headquarters

200 Flynn Road, Camarillo, California 93012

phone: (805) 498-2111 • fax: (805) 498-3804 • email: corporate@gennum.com • www.semtech.com