

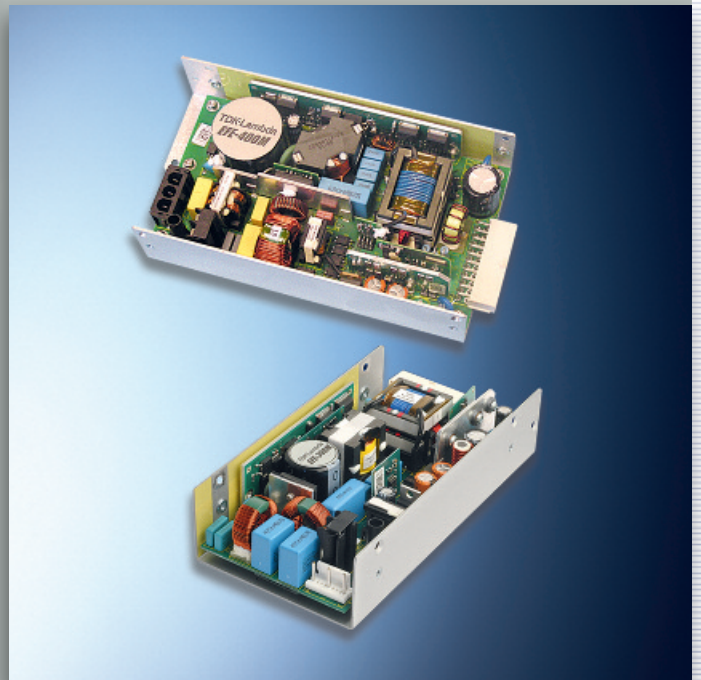

Power Products

AC-DC Power Supplies
DC-DC Converters
EMI Filters



2011



Innovating Reliable Power

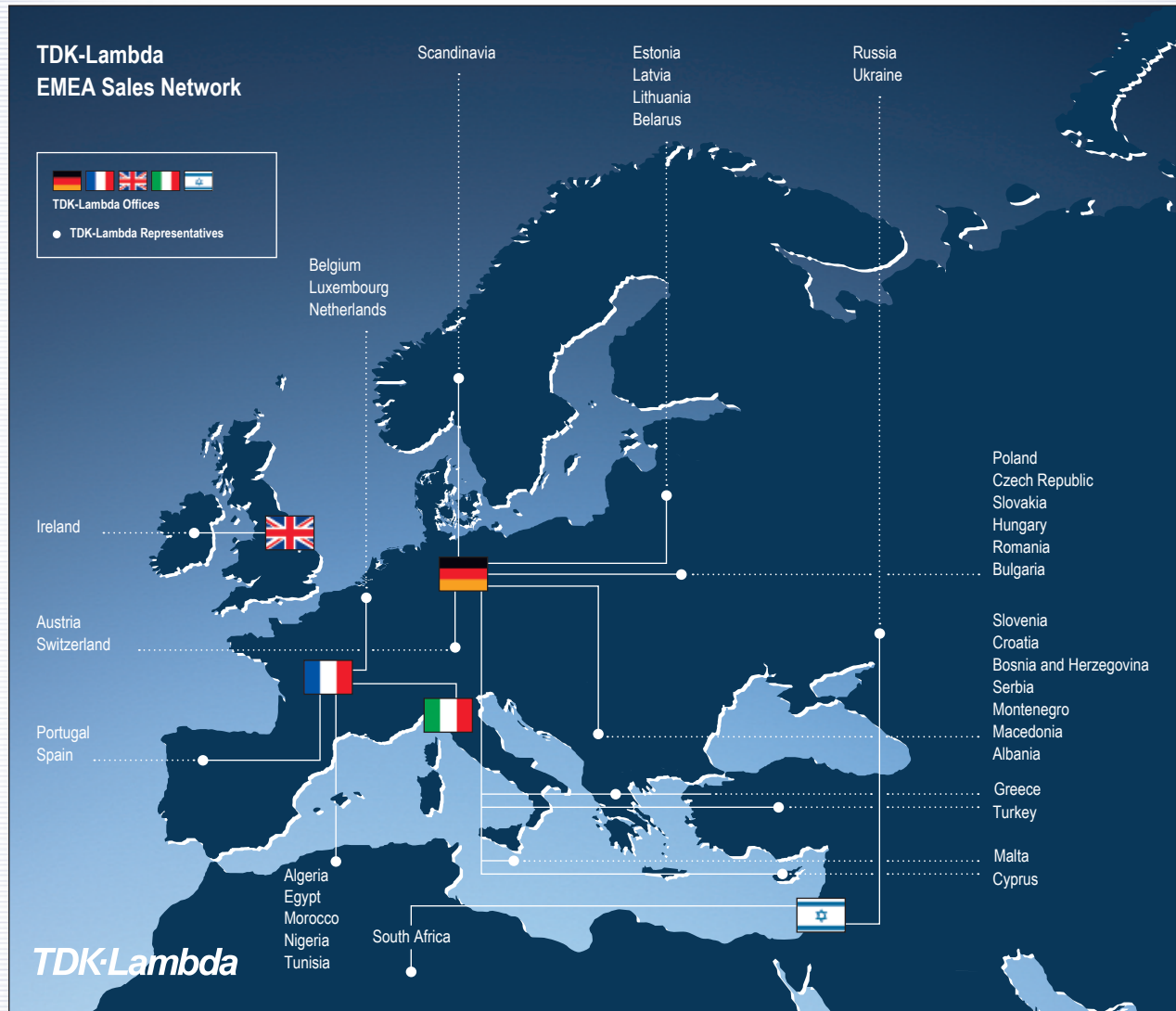

More detailed information:

Visit our website and discover the many possibilities offered by TDK-Lambda.

Browse through the latest product highlights and download our catalogues and documentation.

www.emea.tdk-lambda.com





Index

New Products Showcase	2	DPP120-240 1PH	143
AC-DC Selector	3	DPP480 1PH	146
AC-DC Selector - Medical	4	DPP120-960 3PH	149
DC-DC Selector - Isolated	5	DPX DC-DC NEW	152
DC-DC Selector - POL	6	HOTSWAP FRONT END	
Shortform Brochure Selector	7	AC-DC POWER SUPPLIES	156
About TDK-Lambda EMEA	8	FPS1000	157
EMBEDDED AC-DC POWER SUPPLIES		HFE 1600 NEW	160
PCB MOUNT, OPEN PCB AND OPEN FRAME	9	LED LIGHTING CONSTANT VOLTAGE	
KPSA	10	AND CONSTANT CURRENT AC-DC POWER SUPPLIES	163
KM	13	ALC/ALV NEW	164
ZPSA20	16	PROGRAMMABLE RACK MOUNT	
ZPSA40/60	19	AND LABORATORY POWER SUPPLIES	166
ZPS40/60 ZPD40 ZPT40	22	GENESYS™	168
ZPSA100	25	ZUP	172
ZWS	28	AC-DC AND DC-DC POWER MODULES (Bricks)	175
ZWS-BAF NEW	31	PFE	176
ZWS-PAF	34	PF	179
ZWQ	37	iSA	182
CSS65 NEW	40	iEA	184
EFE300/400	42	iQE	186
EFE300M/400M NEW	45	iQG	188
ENCLOSED CHASSIS MOUNT		iQL	190
AC-DC POWER SUPPLIES	48	CN-A NEW	192
LS25-150	49	iHG	195
LS200 NEW	54	PAH	197
GWS250/500 NEW	57	PAH300/450	200
HWS15-150	60	PAF500F & PAF600F	203
HWS300-1500	63	PAF450F/600F 280	206
HWS HD	66	PAF700F	209
HWS ME	69	PH-S	212
HWS300-600P	72	PH-F	214
MTW	75	ISOLATED PCB MOUNT AND SURFACE	
RTW	78	MOUNT DC-DC CONVERTERS	216
SWS300A & 600	81	CC-E	217
SWS600L & 1000L	84	CC-P-E	220
RFE1000	87	PXA	223
CPFE500F NEW	89	PXB	226
CPFE1000F NEW	92	PXC	229
LZSA	95	PXD	232
CONFIGURABLE AND MODULAR		PXD30W	235
AC-DC POWER SUPPLIES	98	PXE	238
NV100	99	PXF NEW	241
NV175/180/200	102	NON-ISOLATED POL (point of load) PCB MOUNT	
NV175M (Multi O/P)	107	AND SURFACE MOUNT DC-DC CONVERTERS	244
NVM175 (Single O/P) NEW	110	CE1000/1050	245
NV300	112	iAA/iAC	248
NV350/700	117	iAD	251
Vega	122	PL5	253
Vega Lite	127	PL10-20S	256
Alpha 1000/1500	132	PL10-20SMS	259
DIN RAIL MOUNTING AC-DC POWER SUPPLIES		FILTERS	262
AND DC-DC CONVERTERS	136	SPECIAL ASSEMBLIES / CUSTOM	263
DSP	137		
DPP15-100	140		



NEW Products Showcase

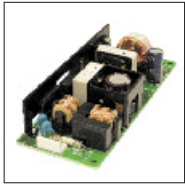

ZWS-BAF 100 & 150W long-life AC-DC power supplies
www.emea.tdk-lambda.com/zws-baf

Page No.

31



CSS65 "2 x 4" 40 to 65W AC-DC medical power supplies
www.emea.tdk-lambda.com/css

40

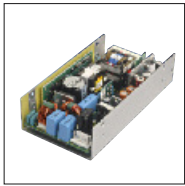

EFE400M 400 Watts, medical (BF rated) AC-DC digital power supply
www.emea.tdk-lambda.com/efe-m

45



LS200 200W AC-DC general purpose power supply
www.emea.tdk-lambda.com/ls

54

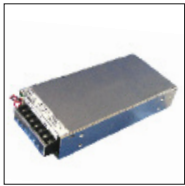

GWS250/500 250 & 500W AC-DC power supplies, ErP compliant
www.emea.tdk-lambda.com/gws

57

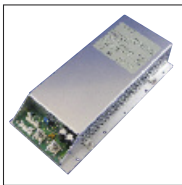

CPFE500F 500W AC-DC power supply conduction/baseplate cooled
www.emea.tdk-lambda.com/cpfe

89



CPFE1000F 1000W AC-DC power supply conduction/baseplate cooled
www.emea.tdk-lambda.com/cpfe

92

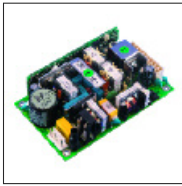

NVM175 (Single O/P) 180W medical power supply for BF applications
www.emea.tdk-lambda.com/nv

110



DPX DC-DC 15-60W single, dual & triple output, DIN-Rail DC-DC converters
www.emea.tdk-lambda.com/dpx

152



HFE 1600
1600W 1U hot swap front end power supplies
www.emea.tdk-lambda.com/hfe

160

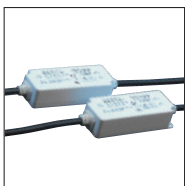

ALC/ALV 12W AC-DC IP66 LED power supply
www.emea.tdk-lambda.com/al

164



CN-A 30W - 200W 110VDC input for railway applications
www.emea.tdk-lambda.com/cn-a

192



AC-DC Selector

PCB Mount	Embedded Open PCB	Enclosed Chassis Mount	Configurable & Modular	Power Module
DIN Rail	Hot Swap Front End	LED	Programmable	Enclosed Baseplate Cooled

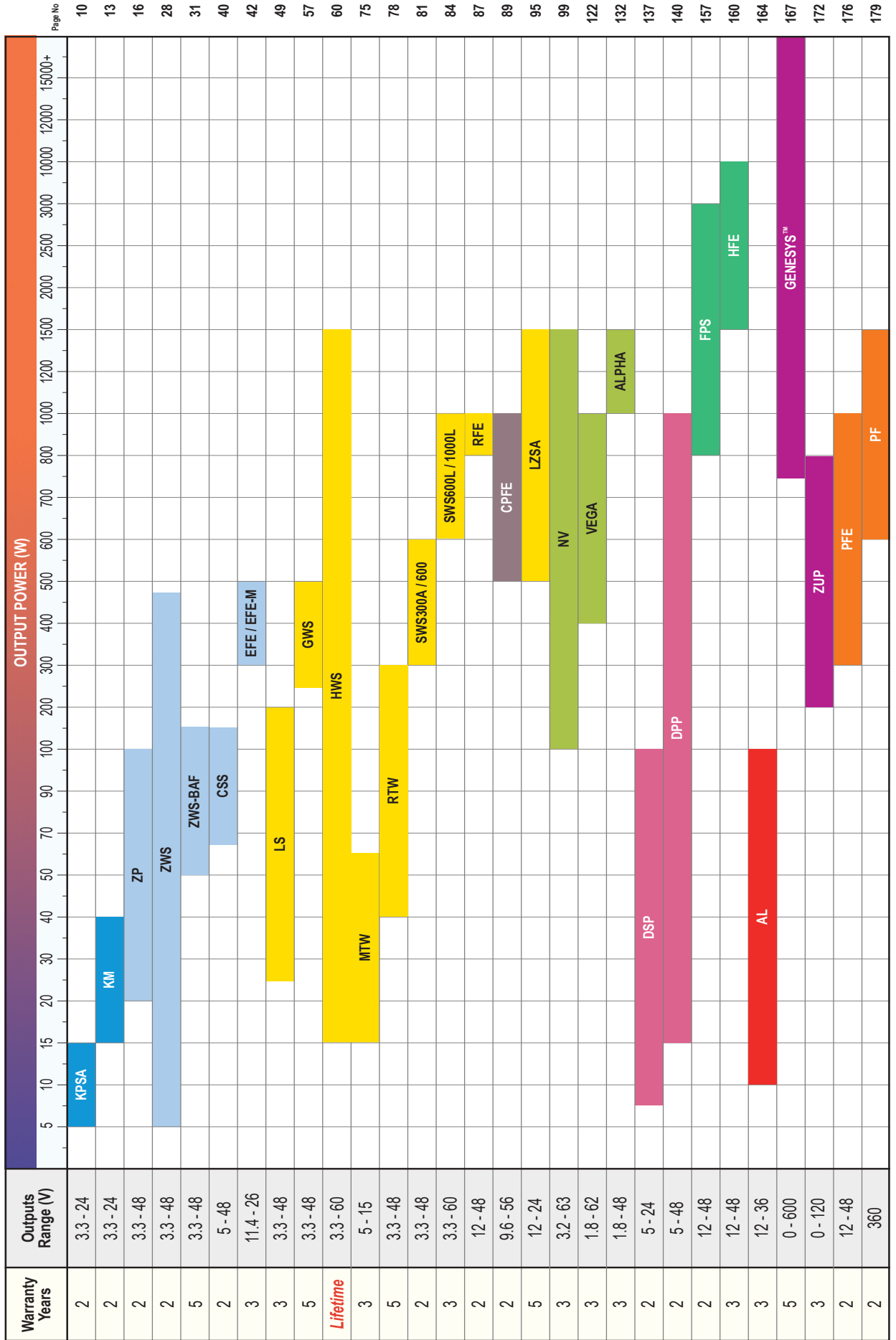

Page No

- 10
- 13
- 16
- 28
- 31
- 40
- 42
- 49
- 57
- 60
- 75
- 78
- 81
- 84
- 87
- 89
- 95
- 99
- 122
- 132
- 137
- 140
- 157
- 160
- 164
- 167
- 172
- 176
- 179



AC-DC Selector - Medical

PCB Mount	Embedded Open PCB	Enclosed Chassis Mount	Configurable & Modular
-----------	-------------------	------------------------	------------------------

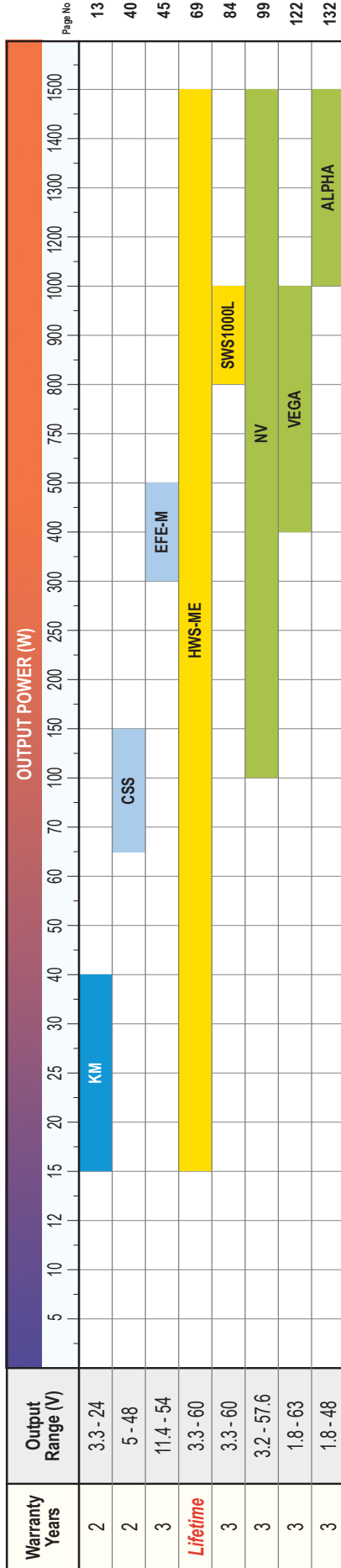

Page No
13
40
45
69
84
99
122
132

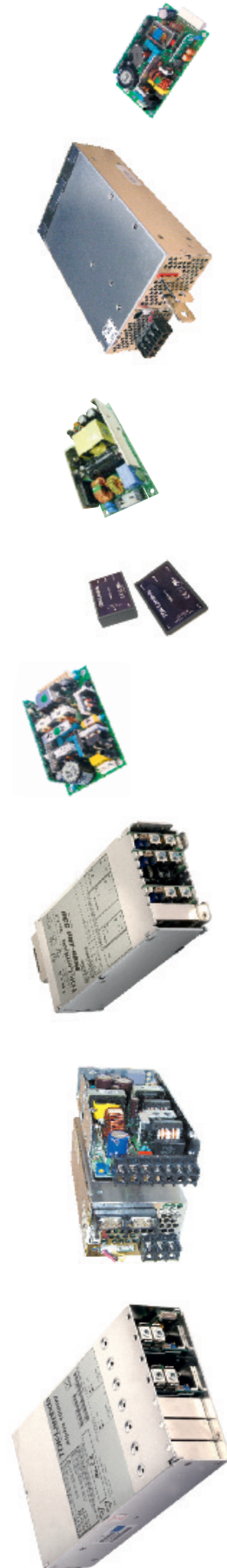



PCB Mount	PCB or Surface Mount	Modular Chassis Mount	DIN Rail	PCB Mount Power Module
-----------	----------------------	-----------------------	----------	------------------------

DC-DC Selector - Isolated

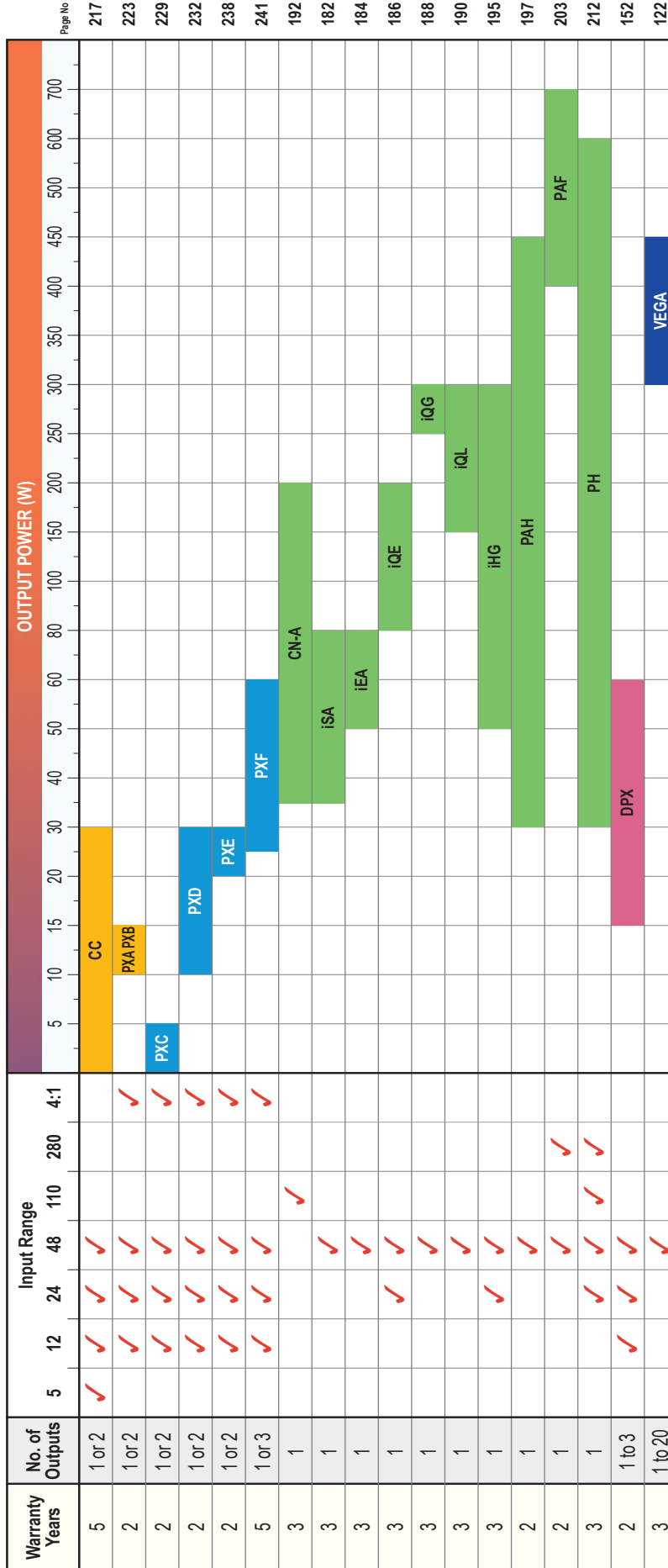



DC-DC Selector - POL

Surface Mount or PCB Pins

PCB Pins

Surface Mount

Output Voltage Range	Input Range		OUTPUT CURRENT (A)																
	3-5.25	3-5.5	6-14	2	3	4.5	6	7	8	10	12	14	15	16	20				
1.0 to 5.0	✓		✓	CE															
0.75 to 3.63		✓									IAA								
0.8 to 5.0			✓											iAC					
0.8 to 5.5			✓											iAD					
0.75 to 5.0	✓		✓												PL				

Page No
 245
 248
 248
 251
 253

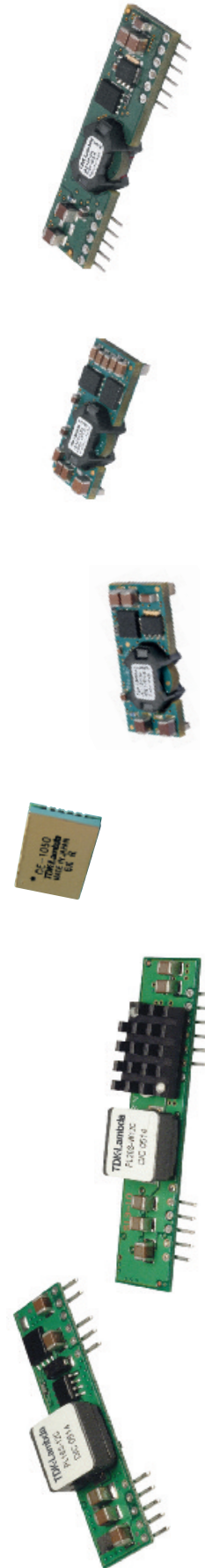



To help you quickly identify the right power supply to fit your application, TDK-Lambda have produced a selection of easy to use shortform brochures. just visit www.emea.tdk-lambda.com or select the link below to download the brochure of your choice or contact us and we'll send you copy. **Simple!**



Custom Power Solutions
6 Page PDF. File size: 2.4mb
www.emea.tdk-lambda.com/custom



DIN Rail Power Supplies
8 Page PDF. File size: 1.8mb
www.emea.tdk-lambda.com/dinrail



Programmable Products News
8 Page PDF. File size: 4.4mb
www.emea.tdk-lambda.com/lab2

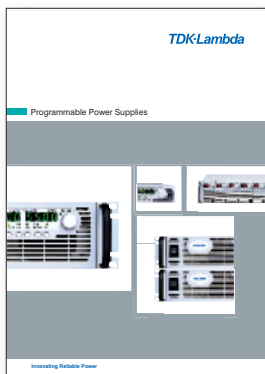

Programmable Power Supplies
64 Page PDF. File size: 2.6mb
www.emea.tdk-lambda.com/lab

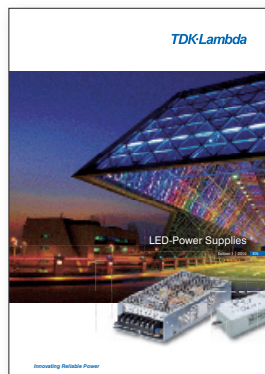

LED Power Supplies
8 Page PDF. File size: 3.4mb
www.emea.tdk-lambda.com/led

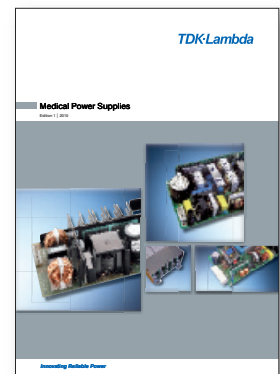

Medical Power Supplies
56 Page PDF. File size: 3.2mb
www.emea.tdk-lambda.com/medical

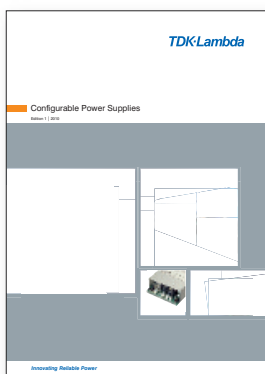

Modular Power Supplies
60 Page PDF. File size: 4.4mb
www.emea.tdk-lambda.com/modular

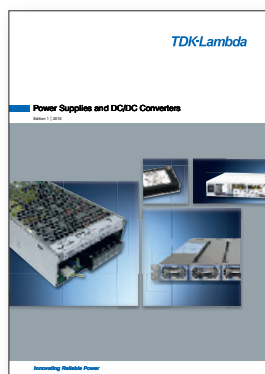

Shortform Power Supply
28 Page PDF. File size: 2.7mb
www.emea.tdk-lambda.com/shortform



With production facilities in Asia, America and Europe, TDK-Lambda has positioned itself as one of the world's largest manufacturers of electronic power supplies. Boasting a comprehensive range of AC-DC power supplies, DC-DC converters and programmable (laboratory) power supplies ranging from 0.7 W to 15 kW, TDK-Lambda offers the right solution for a host of different applications.

A power supply to us is more than just an electronic device. It is the fundamental basis of the safety and reliability of our customers' products. This is why we support you with everything from design, EMC standards and safety certification to mass production, so that we are confident of offering you the best possible solution in every aspect.











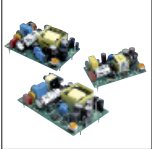

TDK-Lambda

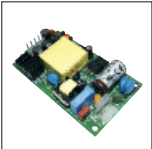
www.emea.tdk-lambda.com

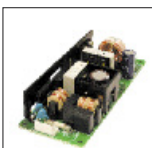

Embedded AC-DC Power Supplies - PCB mount, Open PCB and Open Frame

With output power from 5W to 480W and with an emphasis on design life, reliability and efficiency these products are ideal for integration into all types of OEM equipment including broadcast, medical, instrumentation and LED signage applications. The EFE300M and EFE400M are suitable for BF rated medical applications.

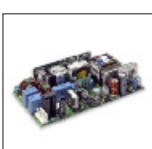
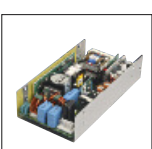
		<i>Page No.</i>
	KPSA Series 4 -15W Single Output	10
	KM Series 10 - 40W Single Output	13
	ZPSA20 Series 20W Single Output	16
	ZPSA40 & 60 Series 40 - 60W Single Output	19
	ZP40 & 60 Series 40- 60W Single, Dual & Triple Output	22
	ZPSA100 Series 100W Single Output	25
	ZWS Series 5 - 50W Single Output	28
	ZWS-BAF Series 100 & 150W Single Output	31
	ZWS-PAF Series 150 - 480W Single Output	34
	ZWQ Series 80 - 130W Quad Output	37
	CSS65 Series 40- 65W Single Output	40
	EFE300/EFE400 Series 300 & 400W Single & Dual Output	42
	EFE300M/EFE400M Series 300 & 400W Single, Dual & Triple Output	45

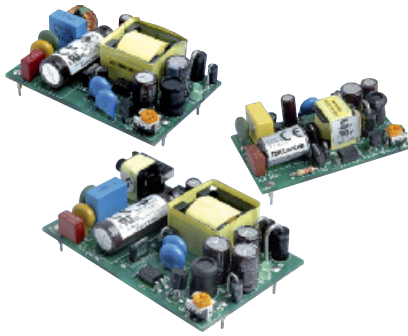

- Small Size & Lightweight
- PCB Board Mountable
- Low Cost
- Universal Input Voltage
- RoHS Compliant

Key Market Segments & Applications

- Factory Automation
- Telecom
- Datacom
- Printers and motor drives
- Instruments

KPSA Series

5 to 15W AC-DC

Board Mount Power Supplies

KPSA Features and Benefits

Features	Benefits
----------	----------

- Small Size
- Wide Input Range
- No External Components Needed

- Minimises PCB Space
- Global use with no manual intervention
- Easy to use

Specifications		KPSA-5	KPSA-10	KPSA-15
ITEMS	MODEL			
Input Voltage range	-	85 - 264VAC (47 - 63Hz) or 100 - 370VDC		
Inrush Current (115 / 230VAC)	A	30A Max at 230VAC		
Input Current	A	0.13 / 0.07	0.27 / 0.13	0.4 / 0.2
Temperature Coefficient	-	±0.05%/°C		
Voltage Accuracy	-	±1%		
Minimum Load	A	None		
Load Regulation	-	±1% (10% to 100% load)		
Line Regulation	(1) -	±0.5%		
Ripple & Noise	(2) mV	1% or 50mV whichever is greater		
Short Circuit Protection	-	Continuous - hiccup mode		
Overvoltage Protection	V	130-150%		
Hold Up Time (Typ@115VAC)	ms	19	16	16
LED Indicator	-	Green LED = OK		
Operating Temperature	°C	0 to +70 with derating		
Storage Temperature	°C	-20 to +85		
Humidity (non condensing)	%RH	10 - 95		
Cooling	-	Convection		
Withstand Voltage	-	Input to Output 3kVAC		
Vibration (non operating)	-	23.52m/s ² (10 - 55Hz: constant sweep 1 min X, Y, Z for 1 hour)		
Shock	-	< 196.1 m/s ² (20G)		
Safety Agency Approvals	-	UL60950-1, CSA60950-1, EN60950-1 Class II, CE Mark		
Conducted & Radiated EMI	-	EN55022-B, FCC Class B		
Immunity	-	EN61000-4 -2, -3, -4, -5, -6		
Weight (Typ)	g	28	40	48
Size (WxLxH; H above pcb)	mm	55 X 33 X 21	61 X 40 X 20	70 X 45 X 20
Warranty	yrs	2		

Notes:

- (1) KPSA-5 Measured from 100 - 240VAC
- (2) Measured with 0.1µF ceramic & 10µF electrolytic at 20MHz BW



Model Selector

Model	Output Voltage (V)	Maximum Output (A)	Peak Load (A)	Output Pwr (W)	Eff (typ)%
KPSA5-3R3	3.3	1.25	-	4.1	70
KPSA5-5	5.0	1.00	-	5.0	70
KPSA5-12	12.0	0.42	-	5.0	70
KPSA5-15	15.0	0.33	-	5.0	70
KPSA5-24	24.0	0.23	-	5.5	77
KPSA10-3R3	3.3	2.50	3.80	8.3	65
KPSA10-5	5.0	2.00	2.80	10.0	70
KPSA10-12	12.0	0.84	1.20	10.1	75
KPSA10-15	15.0	0.67	1.00	10.1	75
KPSA10-24	24.0	0.42	0.65	10.1	78
KPSA15-3R3	3.3	3.00	4.50	9.9	70
KPSA15-5	5.0	3.00	4.50	15.0	73
KPSA15-12	12.0	1.25	1.80	15.0	80
KPSA15-15	15.0	1.00	1.50	15.0	80
KPSA15-24	24.0	0.63	0.95	15.1	82

Derating Curve KPSA Series

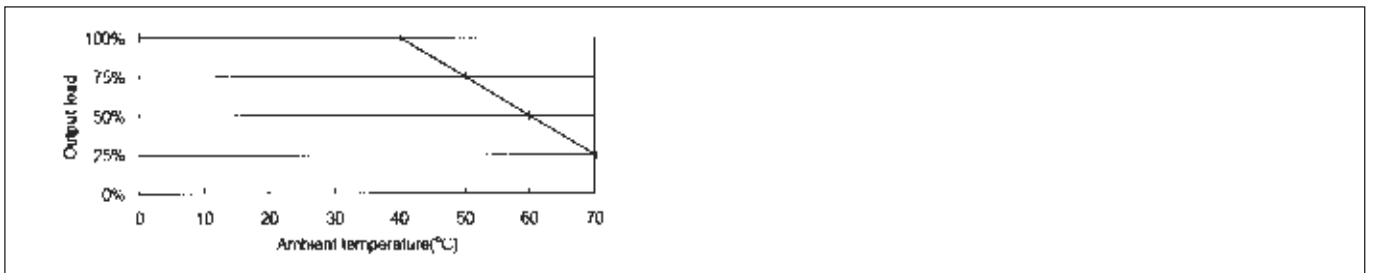

Outline Drawing KPSA5 Series

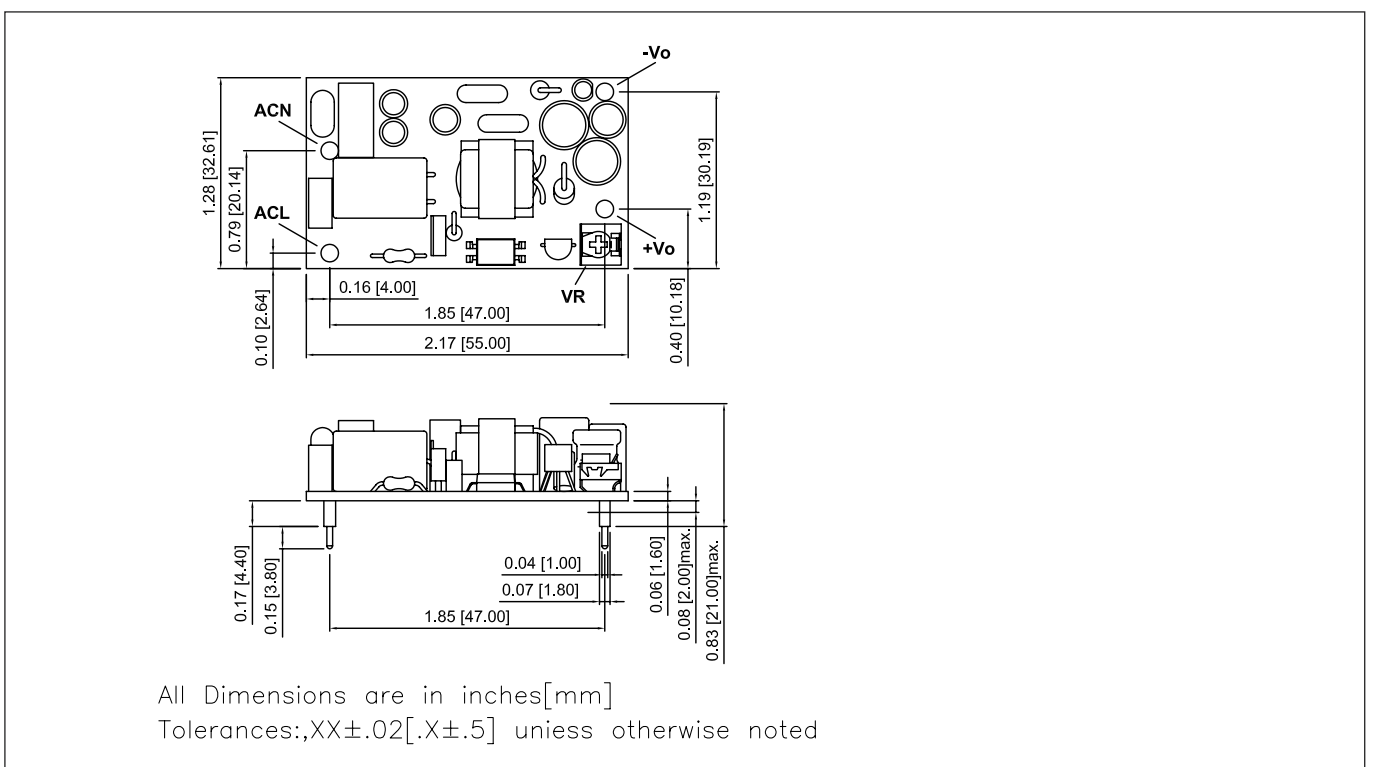



Outline Drawing KPSA10 Series

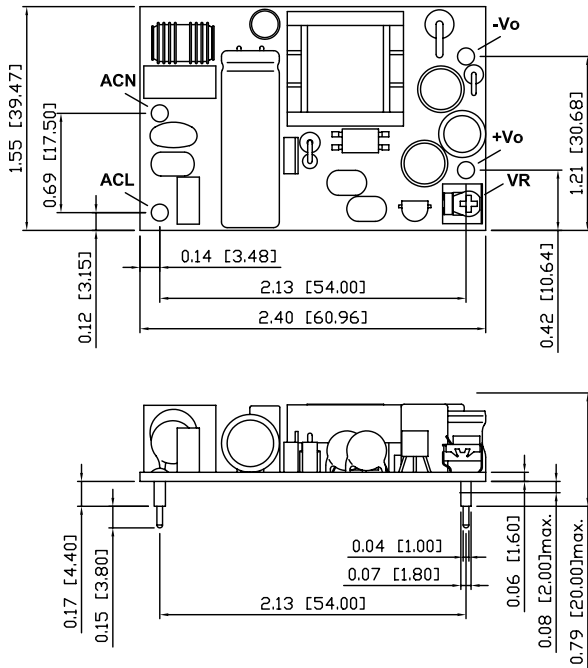

Note: All Dimensions are in inches (mm)
Tolerances: XX±0.2 (.X±.5) unless otherwise noted

Outline Drawing KPSA15 Series

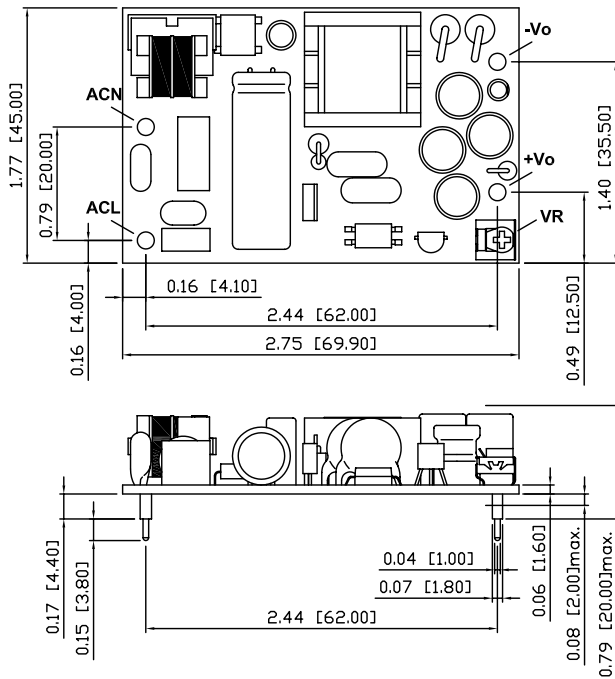

Note: All Dimensions are in inches (mm)
Tolerances: XX±0.2 (.X±.5) unless otherwise noted

INTERMEDIATE VOLTAGES AVAILABLE
PLEASE CONSULT SALES



- Small Size & Lightweight
- PCB Board Mountable
- Wide Range Input
- Medical Safety Certifications (4kVAC Input - Output)
- Class II (No ground needed)

Key Market Segments & Applications

Portable Medical Equipment
General Low Power Applications

KM Series

15 to 40W Medical AC-DC
PCB - Mount Power Supplies

KM Features and Benefits

Features

- Small Size
- Wide Input Range
- High efficiency

Benefits

- Minimises PCB Space
- Global use with no manual intervention
- Lower Heat Dissipated in System

Specifications

MODELS		KMS15	KMD15	KMT15	KMS40	KMD40	KMT40
ITEMS							
Input Voltage Range	-	90-264VAC 47-440Hz or 100-375VDC					
Inrush Current Limiting	A	10 / 20A, cold start, 25°C ambient (115 / 230VAC)					
Input Current (115 / 230VAC)	mA	220 / 118mA			860 / 460mA		
Internal Fuse (live line) ⁽¹⁾	-	250V/T2A			250V/T3.15A		
Temperature Coefficient (O/PV)	-	±0.01%/°C					
Ripple and Noise (pk-pk)	mV	50mV or 1%, whichever is greater					
Overcurrent Protection	-	> 105%, hiccup mode, automatic recovery					
Overvoltage Protection	%	Yes, Zener diode clamp					
Hold-up Time (typical)	ms	20ms			18ms		
Enclosure Leakage 240Vac, 63Hz	mA	0.055 max			0.08 max		
264Vac, 63Hz	mA	0.06 max			0.085 max		
Operating Temperature	-	-25°C to 70°C, derate linearly to 50% load from 50°C to 70°C. Max case temperature 95°C					
Storage Temperature	-	-40°C to 100°C					
Humidity	%RH	20% to 95% RH (non-condensing)					
Cooling	-	Convection, over temperature protected ~100°C case temperature)					
Withstand Voltage	VAC	Input to output: 4kVAC					
Immunity	-	EN60601-1-2					
Safety Agency Certification	-	UL60601-1, IEC60601-1, CE Mark					
Conducted EMI	-	EN55011 Class B			EN55011 Class A ⁽²⁾		
Switching Frequency	kHz	132kHz					
Weight	g	120			280		
Size (LxWxH)	mm	64 x 46 x 24			89 x 64 x 27		
Mounting & Case	-	PC board mountable. Plastic resin fibreglass case (UL 94V-0)					
MTBF	hrs	200,000 to 400,000 hours, model dependent					
Warranty	yrs	2					

Notes:

- (1) For medical applications an equivalent external fuse should be installed in the neutral line
(2) Class I Applications: An external filter can be added to meet EN55011 Class B - see application notes



Model Selector										
Model		Output Voltage (V)	Minimum Current (A)	Maximum Current (A)	Power (W)	Output Set Accuracy (%)	Line Regulation (%)	Load Regulation (1) (%)	Cross Regulation (%)	Efficiency (%)
Single Output										
KMS15-3P3	V1	3.3V	0A	3.00A	9.9W	±2%	0.5%	1%	-	74%
KMS40-3P3	V1	3.3V	80mA	8.00A	26.4W	±2%	0.5%	1%	-	75%
KMS15-5	V1	5V	0A	3.00A	15W	±2%	0.5%	1%	-	78%
KMS40-5	V1	5V	80mA	8.00A	40W	±2%	0.5%	1%	-	79%
KMS15-9	V1	9V	0A	1.67A	15W	±2%	0.5%	1%	-	79%
KMS40-9	V1	9V	44mA	4.44A	40W	±2%	0.5%	1%	-	82%
KMS15-12	V1	12V	0A	1.25A	15W	±2%	0.5%	1%	-	81%
KMS40-12	V1	12V	33mA	3.33A	40W	±2%	0.5%	1%	-	83%
KMS15-15	V1	15V	0A	1.00A	15W	±2%	0.5%	1%	-	81%
KMS40-15	V1	15V	26.7mA	2.67A	40W	±2%	0.5%	1%	-	83%
KMS15-24	V1	24V	0A	0.62A	15W	±2%	0.5%	1%	-	83%
KMS40-24	V1	24V	16.7mA	1.67A	40W	±2%	0.5%	1%	-	83%
Dual Output										
KMD15-55	V1	+5V	150mA	1.5A	15W	±2%	0.5%	1%	5%	78%
	V2	-5V	150mA	1.5A		5%				
KMD40-55	V1	+5V	400mA	4A	40W	±2%	0.5%	1%	5%	79%
	V2	-5V	400mA	4A		5%				
KMD40-512	V1	5V(2)	1250mA	5A	40W	±3%	0.5%	2%	1%	80%
	V2	12V(2)	312mA	1.25A		7%				
KMD40-524	V1	5V(2)	1250mA	5A	40W	±3%	0.5%	2%	1%	80%
	V2	24V(2)	156mA	0.625A		7%				
KMD15-1212	V1	+12V	62.5mA	0.625A	15W	±2%	0.5%	1%	3%	80%
	V2	-12V	62.5mA	0.625A		3%				
KMD40-1212	V1	+12V	166mA	1.66A	40W	±2%	0.5%	1%	5%	83%
	V2	-12V	166mA	1.66A		5%				
KMD15-1515	V1	+15V	50mA	0.5A	15W	±2%	0.5%	1%	3%	81%
	V2	-15V	50mA	0.5A		3%				
KMD40-1515	V1	+15V	133mA	1.33A	40W	±2%	0.5%	1%	5%	81%
	V2	-15V	133mA	1.33A		5%				
Triple Output										
KMT15-51212	V1	5V(3)	500mA	2A	15W	±2%	0.5%	1%	1%	78%
	V2	+12V	50mA	0.2A		5%				
	V3	-12V	50mA	0.2A		5%				
KMT40-51212	V1	5V(3)	1250mA	5A	40W	±3%	0.5%	3%	3%	80%
	V2	+12V	150mA	0.6A		7%				
	V3	-12V	150mA	0.6A		7%				
KMT15-51515	V1	5V(3)	500mA	2A	15W	±2%	0.5%	1%	1%	78%
	V2	+15V	37.5mA	0.15A		5%				
	V3	-15V	37.5mA	0.15A		5%				
KMT40-51515	V1	5V(3)	1250mA	5A	40W	±3%	0.5%	3%	3%	80%
	V2	+15V	125mA	0.5A		7%				
	V3	-15V	125mA	0.5A		7%				

Pinout KM15			
PIN #	Function		
	Single O/P	Dual O/P	Triple O/P
1	No Pin	No Pin	No Pin
2	AC (L)	AC (L)	AC (L)
3	AC (N)	AC (N)	AC (N)
4	-DC	-DC	+5V GND
5	No Pin	GND	+5V
6	No Pin	No Pin	-DC
7	+DC	+DC	No Pin
8	No Pin	No Pin	GND
9	No Pin	No Pin	+DC

Pinout KM40				
PIN #	Function			
	Single O/P	Dual O/P	5S/12&24S	Triple O/P
1	AC (L)	AC (L)	AC (L)	AC (L)
2	AC (N)	AC (N)	AC (N)	AC (N)
3	+DC	+DC	+O/P2	+DC
4	No Pin	No Pin	+O/P1	+5V
5	-DC	GND	GND1	GND
6	No Pin	No Pin	GND2	+5V GND
7	No Connection	-DC	No Connection	-DC



Outline Drawing KM15 Series

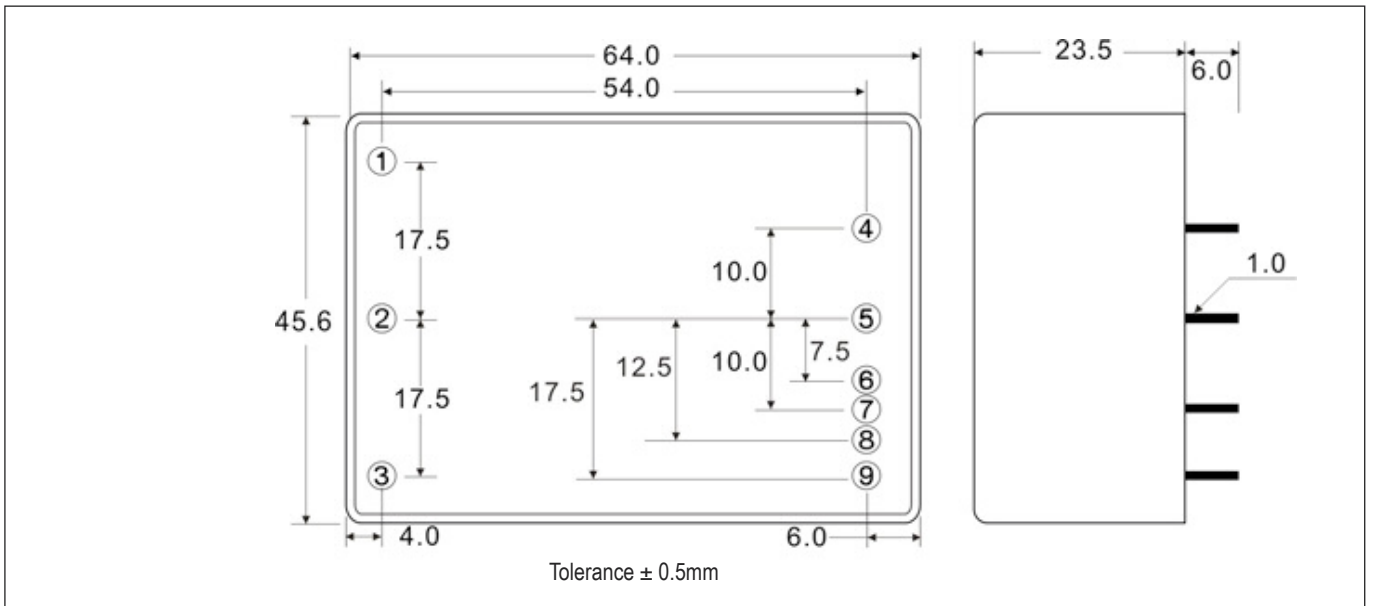

Outline Drawing KM40 Series

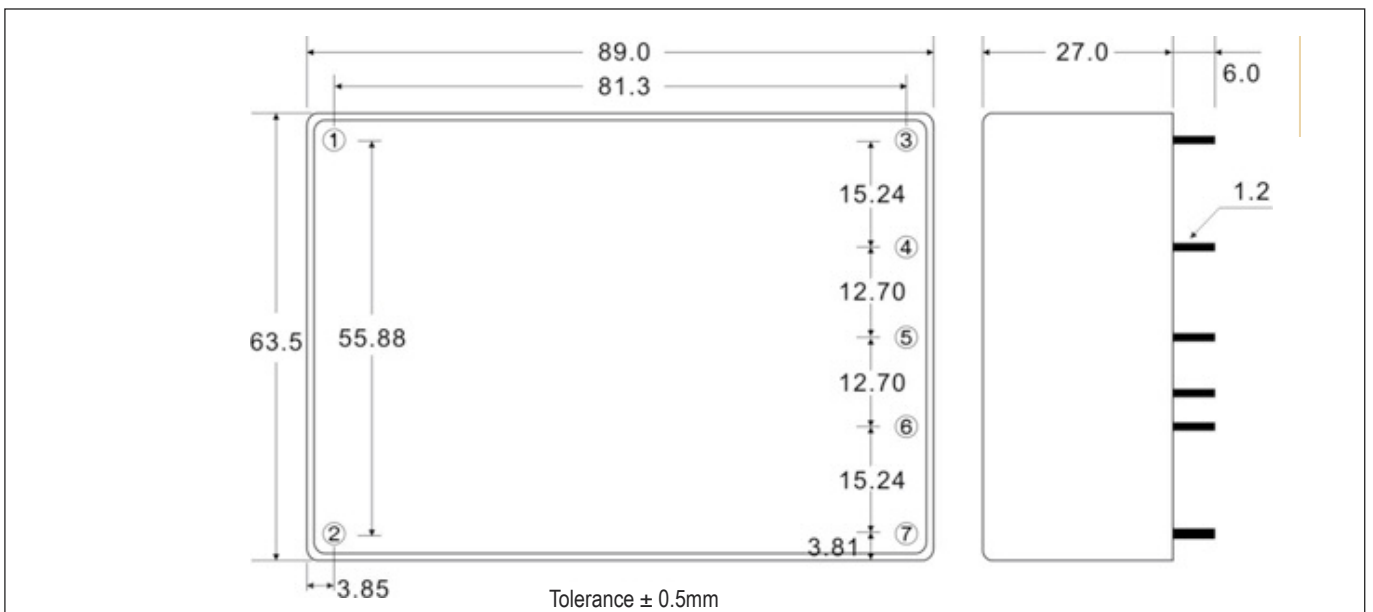

Notes: (1) Symmetrical loading, from minimum to maximum load (2) Output V1 is isolated from output V2 (3) Output V1 is isolated from outputs V2 & V3

Derating Curves KM15 Series

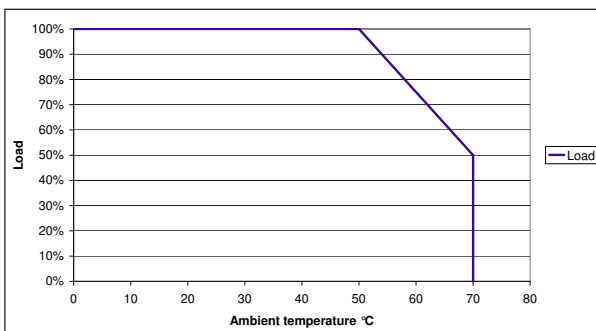

Derating Curves KM40 Series

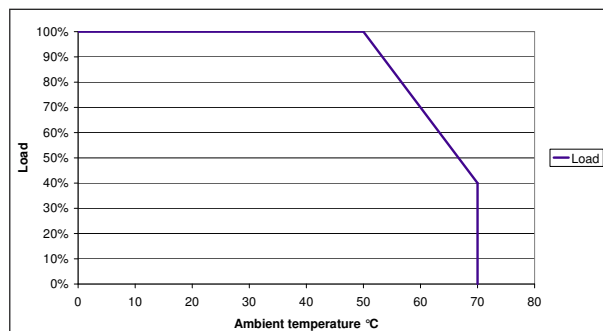



- Wide Range AC Input
- Low Profile, Industry Standard Footprint
- Global Safety Agency Compliance
- RoHS Compliant

ZPSA20 Series

2" x 3.5" 20W AC-DC Power Supplies

Key Market Segments & Applications

- Video/Audio Routers
- Datacom
- Point of Sale
- Test and Measurement
- LED Signs and Lighting

ZPSA20 Features and Benefits

Features

- Industry Standard Footprint
- Up to 82% efficiency
- Broad Product Range
- Meets EN61000-4 Immunity

Benefits

- Available to Second Source
- Less System Heating
- Optimization of Power Supply to System
- Greater Reliability

Specifications

ITEMS		MODEL	ZPSA20
Input Voltage range	(1)	-	85 - 264VAC (47 - 440Hz) or 120 - 370VDC
Inrush Current		A	40A max at 240VAC input, 25°C ambient cold start,
Input Current (115/230VAC)		A	0.25 / 0.12
Leakage Current		mA	0.6mA maximum (264VAC, 60Hz)
Temperature Coefficient		-	±0.05%/°C
Voltage Accuracy		-	±1%
Minimum Load		A	None
Load Regulation		-	±1%
Line Regulation		-	±0.5%
Ripple & Noise	(2)	mV	1% or 50mV whichever is greater
Short Circuit Protection		-	Continuous - hiccup mode
Overvoltage Protection		V	Typically 110-130% of nominal
Hold Up Time (Typ)		ms	16ms at 115VAC input
Operating Temperature			0 to +70°C with derating
Storage Temperature		-	-20 to +85°C
Humidity (non condensing)		-	10 - 95% RH
Cooling		-	Convection
Withstand Voltage			Input to Ground 1.5kVAC, Input to Output 3kVAC, Output to Ground 500VAC for 1 min.
Isolation Resistance			>100ΩM at 25°C & 70%RH, Output to Ground 500VDC
Vibration (non operating)			23.52m/s ² (10 - 55Hz: constant sweep 1 min X, Y, Z for 1 hour)
Shock		-	< 196.1 m/s ² (20G)
Safety Agency Approvals		-	UL60950, CSA60950, EN60950-1 Class 1, CE Mark (LVD)
Conducted & Radiated EMI		-	EN55022-B, FCC Class B
Immunity		-	EN61000-4-2,-3,-4,-6,-8
Weight (Typ)		g	100g
Size (WxLxH)		mm	88.9 X 50.8 X 20.32 (including underside components)
Warranty		yrs	2

Notes:

- (1) Safety certified for 47 - 63Hz input only (2) Measured with 0.1μF ceramic & 10μF electrolytic at 20MHz BW



Model Selector

Model	Output Voltage (V)	Maximum Output (A)	Peak Load (A) (1)	Efficiency (2) (typ)%	
ZPSA20-3R3	V1	3.3	4.4	6.6	74
ZPSA20-5	V1	5.0	4.4	6.6	77
ZPSA20-9	V1	9.0	2.4	4.0	80
ZPSA20-12	V1	12.0	1.8	2.7	80
ZPSA20-15	V1	15.0	1.4	2.1	80
ZPSA20-24	V1	24	0.9	1.4	82

Notes: (1) Average not to exceed max power, <30s, 10% duty cycle
(2) Preliminary Data

Derating Curve ZPSA20 Series

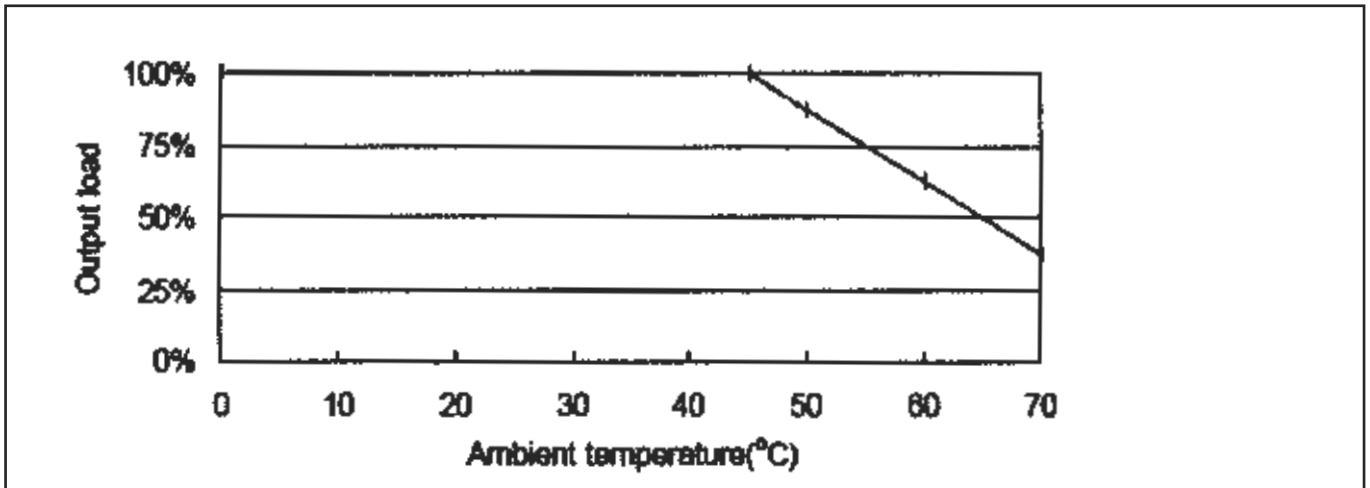

INTERMEDIATE VOLTAGES AVAILABLE
PLEASE CONSULT SALES



Outline Drawing ZPSA20 Series

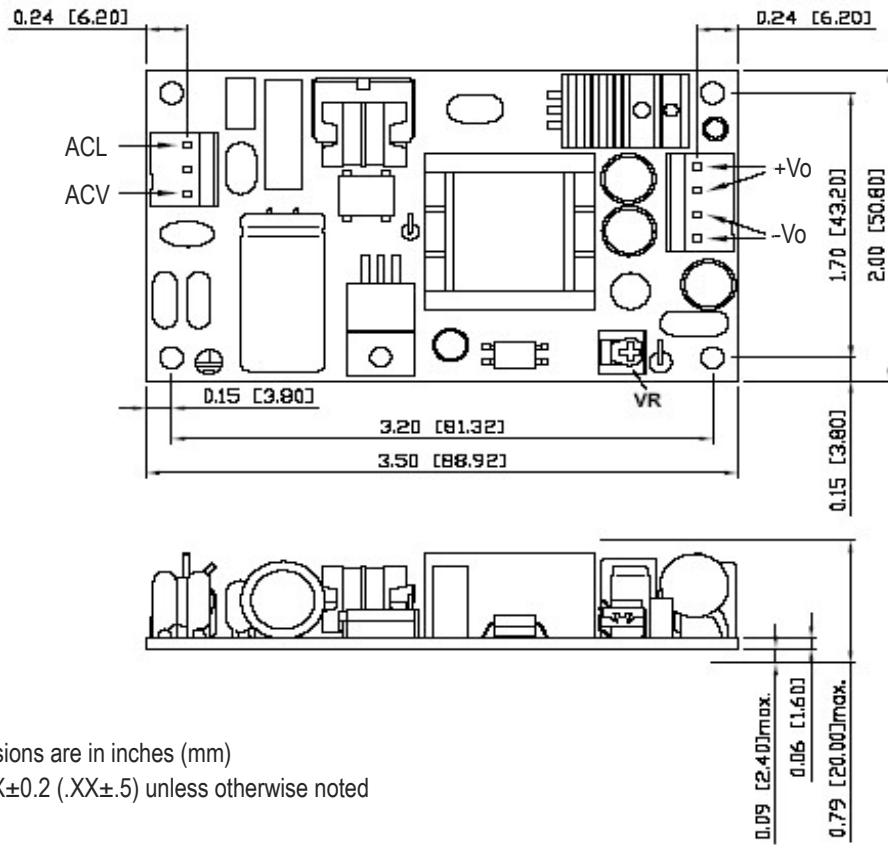

Note: All Dimensions are in inches (mm)
Tolerances: XX±0.2 (.XX±.5) unless otherwise noted

Options

Suffix

Add Suffix -P for PCB Mount Pins

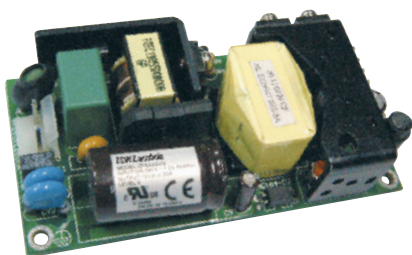

- Single and Multiple Outputs
- Wide Range AC Input
- Low Profile, Industry Standard Footprint
- Global Safety Agency Compliance
- RoHS Compliant

Key Market Segments & Applications

- Video/Audio Routers
- Datacom
- Point of Sale
- Test and Measurement
- LED Signs and Lighting

ZPSA40 & 60 Series

2" x 4" 40W to 60W
AC-DC Power Supplies

ZPSA40 & 60 Features and Benefits

Features

- Industry Standard Footprint
- Up to 88% efficiency
- Broad Product Range
- Meets EN61000-4 Immunity

Benefits

- Available to Second Source
- Less System Heating
- Optimization of Power Supply to System
- Greater Reliability

Specifications

MODEL		ZPSA40	ZPSA60
ITEMS			
Input Voltage range	-	90 - 264VAC (47 - 440Hz) or 120 - 370VDC	
Inrush Current (132/265VAC)	A	25 / 50	
Input Current (115/230VAC)	A	< 1.2A	< 1.4A
Leakage Current	mA	0.8mA max (264VAC, 60Hz)	
Temperature Coefficient	-	±0.05%/°C	
Voltage Accuracy	-	±1%	
Minimum Load	A	None	
Load Regulation	-	±1%	
Line Regulation	-	±0.5%	
Ripple & Noise (1)	mV	1% or 50mV whichever is greater	
Short Circuit Protection	-	Continuous - hiccup mode	
Overvoltage Protection	V	Typically 110-130% of nominal	
Hold Up Time (Typ)	ms	8ms at 115VAC input	
LED Indicator	-	Green LED = OK	
Operating Temperature		0 to +70°C with derating	
Storage Temperature	-	-20 to +85°C	
Humidity (non condensing)	-	10 - 95% RH	
Cooling	-	Convection	
Withstand Voltage		Input to Ground 1.5kVAC, Input to Output 3kVAC, Output to Ground 500VAC for 1 min.	
Isolation Resistance		>100MΩ at 25C & 70%RH, Output to Ground 500VDC	
Vibration (non operating)		23.52m/s ² (10 - 55Hz: constant sweep 1 min X, Y, Z for 1 hour)	
Shock	-	< 196.1 m/s ² (20G)	
Safety Agency Approvals	-	UL60950-1, CSA60950-1, EN60950-1 Class I, CE Mark (LVD)	
Conducted & Radiated EMI	-	EN55022-B, FCC Class B	
Immunity	-	EN61000-4-2,-3,-4,-5,-6,-8	
Weight (Typ)	g	130g	
Size (WxLxH)	mm	101.6 X 50.8 X 27.1 (including underside components)	
Warranty	yrs	2	

Notes: (1) Measured with 0.1μF ceramic & 10μF electrolytic at 20MHz BW



Model Selector

Model		Output Voltage (V)	Maximum Output (A)	Peak Load (A) (2)	Output Power (W)	Efficiency (typ)%
ZPSA40-3R3	V1	3.3	6.0	7.2	20.0	74
ZPSA60-3R3	V1	3.3	8.0	8.5	26.0	74
ZPSA40-5	V1	5.0	6.0	7.2	30.0	79
ZPSA60-5	V1	5.0	8.0	9.0	40.0	79
ZPSA40-9	V1	9.0	4.45	5.34	40.0	83
ZPSA60-9	V1	9.0	6.67	8.0	60.0	83
ZPSA40-12	V1	12.0	3.34	4.0	40.0	85
ZPSA60-12	V1	12.0	5.0	6.0	60.0	85
ZPSA40-15	V1	15.0	2.67	3.2	40.0	85
ZPSA60-15	V1	15.0	4.0	4.8	60.0	85
ZPSA40-24	V1	24.0	1.67	2.0	40.0	86
ZPSA60-24	V1	24.0	2.5	3.0	60.0	86
ZPSA40-28	V1	28.0	1.43	1.71	40.0	86
ZPSA60-28	V1	28.0	2.14	2.57	60.0	86
ZPSA40-30	V1	30.0	1.33	1.6	40.0	87
ZPSA60-30	V1	30.0	2.0	2.4	60.0	87
ZPSA40-36	V1	36.0	1.11	1.33	40.0	87
ZPSA60-36	V1	36.0	1.67	2.0	60.0	87
ZPSA40-48	V1	48.0	0.834	1.0	40.0	88
ZPSA60-48	V1	48.0	1.25	1.5	60.0	88

Notes: (2) Average not to exceed max power, <30s, 10% duty cycle

Derating Curve ZPSA40 & 60 Series

**INTERMEDIATE VOLTAGES AVAILABLE
PLEASE CONSULT SALES**

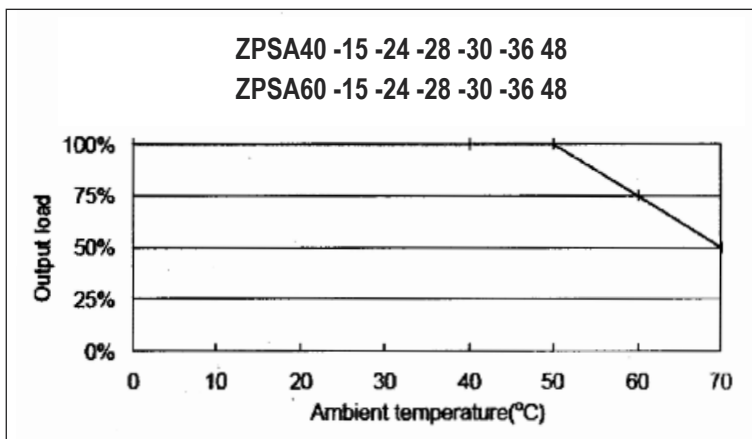
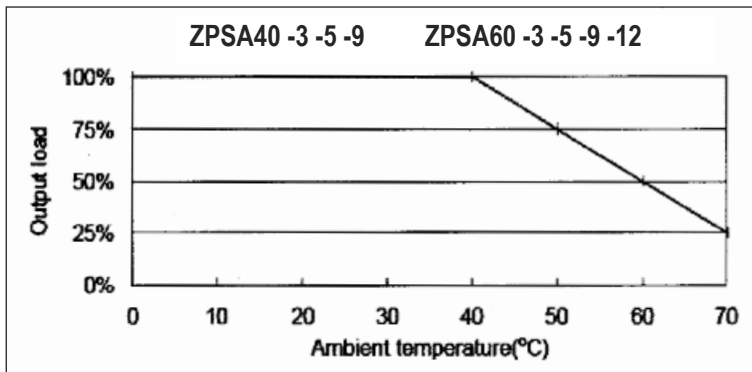



Outline Drawing ZPSA40 & 60 Series

Note: All Dimensions are in inches (mm)
Tolerances: XX±0.2 (.XX±.5) unless otherwise noted

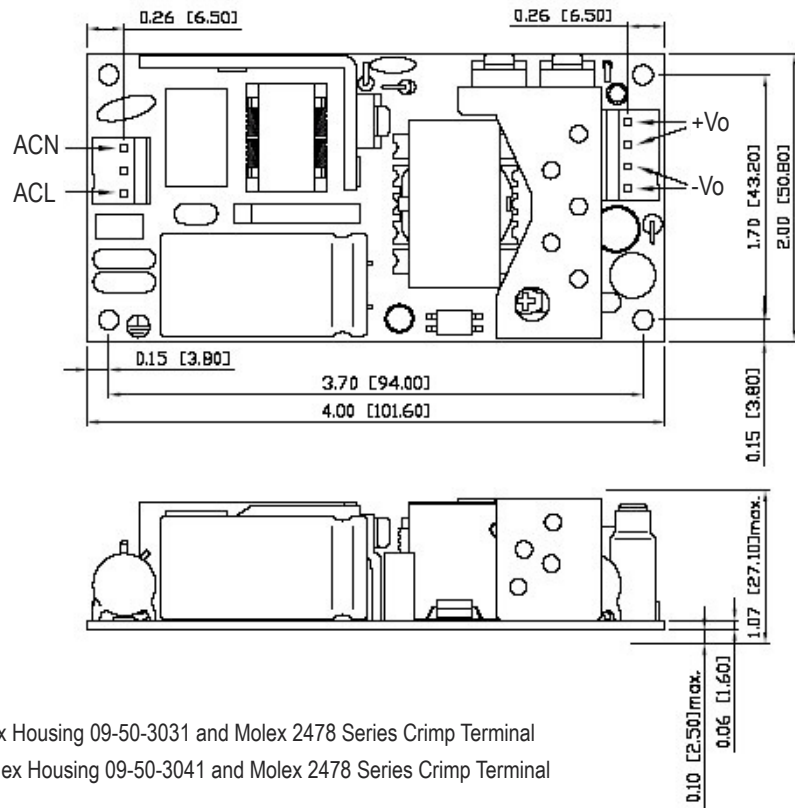

Input Connector Mates with Molex Housing 09-50-3031 and Molex 2478 Series Crimp Terminal
Output Connector Mates with Molex Housing 09-50-3041 and Molex 2478 Series Crimp Terminal

Options	
Suffix	Description
Blank	Molex connectors
/P	PCB mount pins

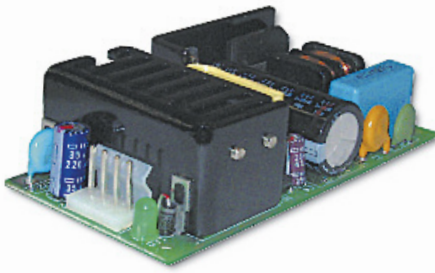

- Single and Multiple Outputs
- Wide Range AC Input
- Low Profile, Industry Standard Footprint
- Global Safety Agency Compliance
- RoHS Compliant

Key Market Segments & Applications

- Video/Audio Routers
- Datacom
- Point of Sale
- Test and Measurement
- LED Signs and Lighting

ZP40 & 60 Series

2" x 4" 40W to 60W
AC-DC Power Supplies

ZP40 & 60 Features and Benefits

Features

- Industry Standard Footprint
- Up to 88% efficiency
- Broad Product Range
- Meets EN61000-4 Immunity

Benefits

- Available to Second Source
- Less System Heating
- Optimization of Power Supply to System
- Greater Reliability

Specifications

ITEMS		MODEL	ZPS40	ZPS60	ZPD40	ZPT40
Input Voltage range		-	90 - 264VAC (47 - 440Hz) or 120 - 370VDC			
Inrush Current (132/265VAC)		A	25 / 50 (cold start)			
Input Current (115/230VAC)		A	1.6 / 1.0			
Temperature Coefficient		-	±0.05%/°C			
Voltage Accuracy		-	±1%		V1: ±3%, V2: ±4%, V3: ±3%	
Minimum Load		A	None		V1: 0.4A, V2: 0.2A	
Load Regulation (1)		-	±1%		V1: ±3%, V2: ±5%, V3: ±1%	
Line Regulation (2)		-	±0.5%		V1: ±1%, V2: ±2%, V3: ±1%	
Ripple & Noise (3)(4)		mV	1% or 50mV whichever is greater			
Short Circuit Protection		-	Continuous - hiccup mode			
Overvoltage Protection		V	Typically 110-130% of nominal			
Hold Up Time (Typ)		ms	8ms at 115VAC input			
LED Indicator		-	Green LED = OK		None	
Operating Temperature		-	0 to +70°C with derating			
Storage Temperature		-	-20 to +85°C			
Humidity (non condensing)		-	10 - 95% RH			
Cooling		-	Convection			
Withstand Voltage		-	Input to Ground 1.5kVAC, Input to Output 3kVAC, Output to Ground 500VAC for 1 min.			
Isolation Resistance		-	>100MΩ at 25°C & 70%RH, Output to Ground 500VDC			
Vibration (non operating)		-	23.52m/s ² (10 - 55Hz: constant sweep 1 min X, Y, Z for 1 hour)			
Shock		-	< 196.1 m/s ² (20G)			
Safety Agency Approvals		-	UL60950-1, CSA60950-1, EN60950-1 Class I, CE Mark (LVD)			
Conducted & Radiated EMI		-	EN55022-B, FCC Class B			
Immunity		-	EN61000-4-2,-3,-4,-5,-6,-8			
Weight (Typ)		g	180g			
Size (WxLxH)		mm	101.6 X 50.8 X 30.48 (including underside components)			
Warranty		yrs	2			

Notes:

- (1) ZPD, ZPT for a 60% to 100% or 100% to 60% change in load
- (2) ZPT40-3512N V2: ±3%, ZPS/ZPD40: 100-240VAC
- (3) Measured with 0.1µF ceramic & 10µF electrolytic at 20MHz BW
- (4) ZPT40-3512N, V1 & V2 100mV



Model Selector

	Model		Output Voltage (V)	Maximum Output (A)	Peak Load (A) (5)	Output Pwr (W)	Eff.(3) (typ)%
Single Output	ZPS40-3R3	V1	3.3	6.0	7.2	20.0	74
	ZPS60-3R3	V1	3.3	8.0	8.5	26.0	74
	ZPS40-5	V1	5.0	6.0	7.2	30.0	78
	ZPS60-5	V1	5.0	8.0	9.0	40.0	78
	ZPS40-9	V1	9.0	4.45	5.34	40.0	82
	ZPS60-9	V1	9.0	6.67	8.0	60.0	82
	ZPS40-12	V1	12.0	3.34	4.0	40.0	84
	ZPS60-12	V1	12.0	5.0	6.0	60.0	84
	ZPS40-15	V1	15.0	2.67	3.2	40.0	85
	ZPS60-15	V1	15.0	4.0	4.8	60.0	85
	ZPS40-24	V1	24.0	1.67	2.0	40.0	86
	ZPS60-24	V1	24.0	2.5	3.0	60.0	86
	ZPS40-28	V1	28.0	1.43	1.71	40.0	86
	ZPS60-28	V1	28.0	2.14	2.57	60.0	86
	ZPS40-30	V1	30.0	1.33	1.6	40.0	86
	ZPS60-30	V1	30.0	2.0	2.4	60.0	86
	ZPS40-36	V1	36.0	1.11	1.33	40.0	87
	ZPS60-36	V1	36.0	1.67	2.0	60.0	87
	ZPS40-48	V1	48.0	0.834	1.0	40.0	88
	ZPS60-48	V1	48.0	1.25	1.5	60.0	88
Dual	ZPD40-512 ⁽⁷⁾	V1	+5.0	3.2	5.0	40.0	77
		V2	+12.0	2.0	2.5		
Dual	ZPD40-524 ⁽⁷⁾	V1	+5.0	3.2	5.0	40.0 (6)	78
		V2	+24.0	1.0	1.5		
Triple Output	ZPT40-5125N ⁽⁷⁾	V1	+5.0	3.2	5.0	40.5 (6)	75
		V2	+12.0	2.0	2.5		
		V3	-5.0	0.3	0.5		
	ZPT40-51212N ⁽⁷⁾	V1	+5.0	3.2	5.0	42.6 (6)	75
		V2	+12.0	2.0	2.5		
		V3	-12.0	0.3	0.5		
	ZPT40-51515N ⁽⁷⁾	V1	+5.0	3.2	5.0	42.0 (6)	75
		V2	+15.0	1.5	2.3		
		V3	-15.0	0.3	0.5		
	ZPT40-52412N ⁽⁷⁾	V1	+5.0	3.2	5.0	42.6 (6)	75
		V2	+24.0	1.0	1.5		
		V3	-12.0	0.3	0.5		
	ZPT40-5245N ⁽⁷⁾	V1	+5.0	3.2	5.0	40.5 (6)	75
		V2	+24.0	1.0	1.5		
		V3	-5.0	0.3	0.5		
	ZPT40-52412P ⁽⁷⁾	V1	+5.0	3.2	5.0	42.6 (6)	75
		V2	+24.0	1.0	1.5		
		V3	+12.0	0.3	0.5		
ZPT40-3512N ⁽⁷⁾	V1	+3.3	5.0	7.0	30.0	70	
	V2	+5.0	2.0	3.5			
	V3	-12.0	0.3	0.5			

Notes: (5) Average not to exceed max power, <30s, 10% duty cycle
 (7) Min Load V1: 0.4A, V2: 0.2A

(6) 50 with 30CFM forced air cooling, derate linearly to 35W from 50°C to 70°C

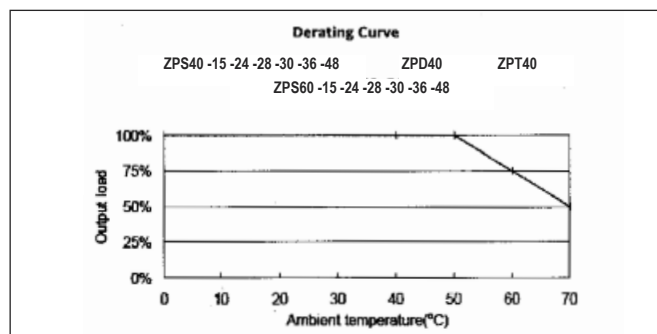
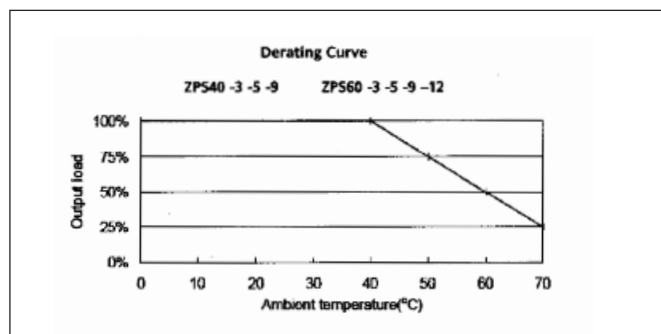



Outline Drawing ZPS Series

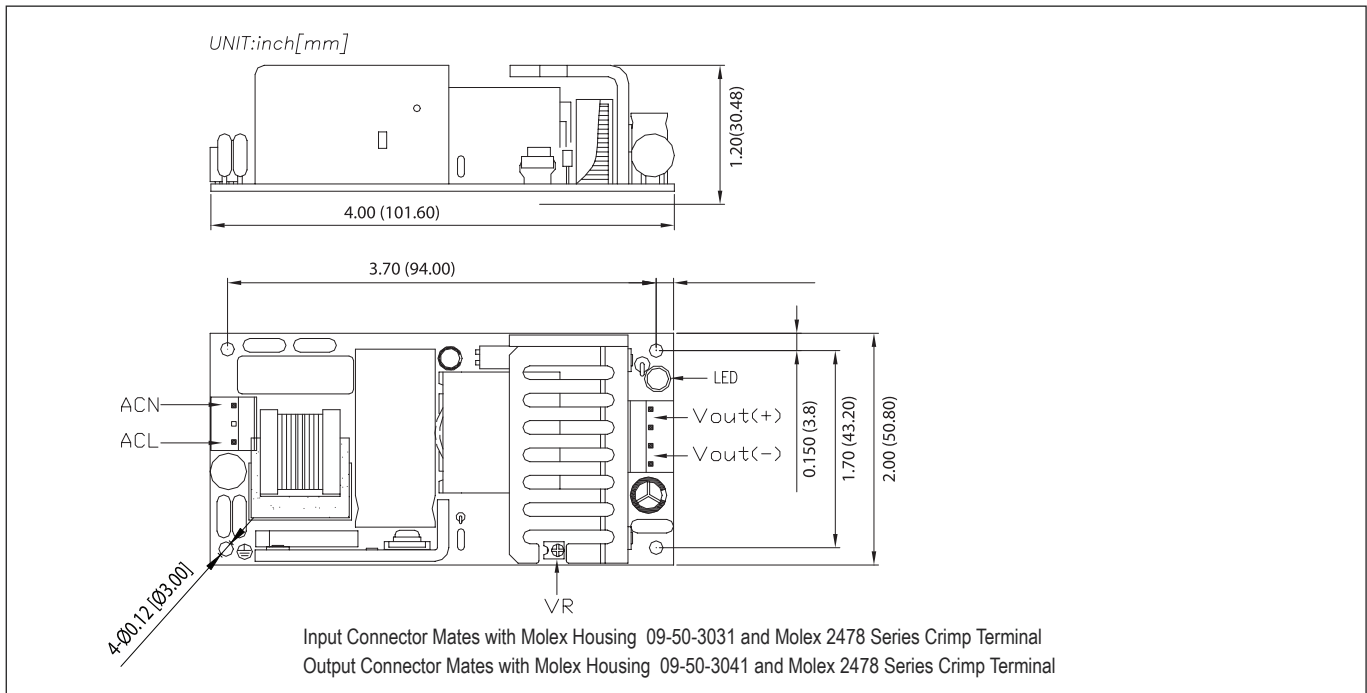

Outline Drawing ZPD/ZPT Series

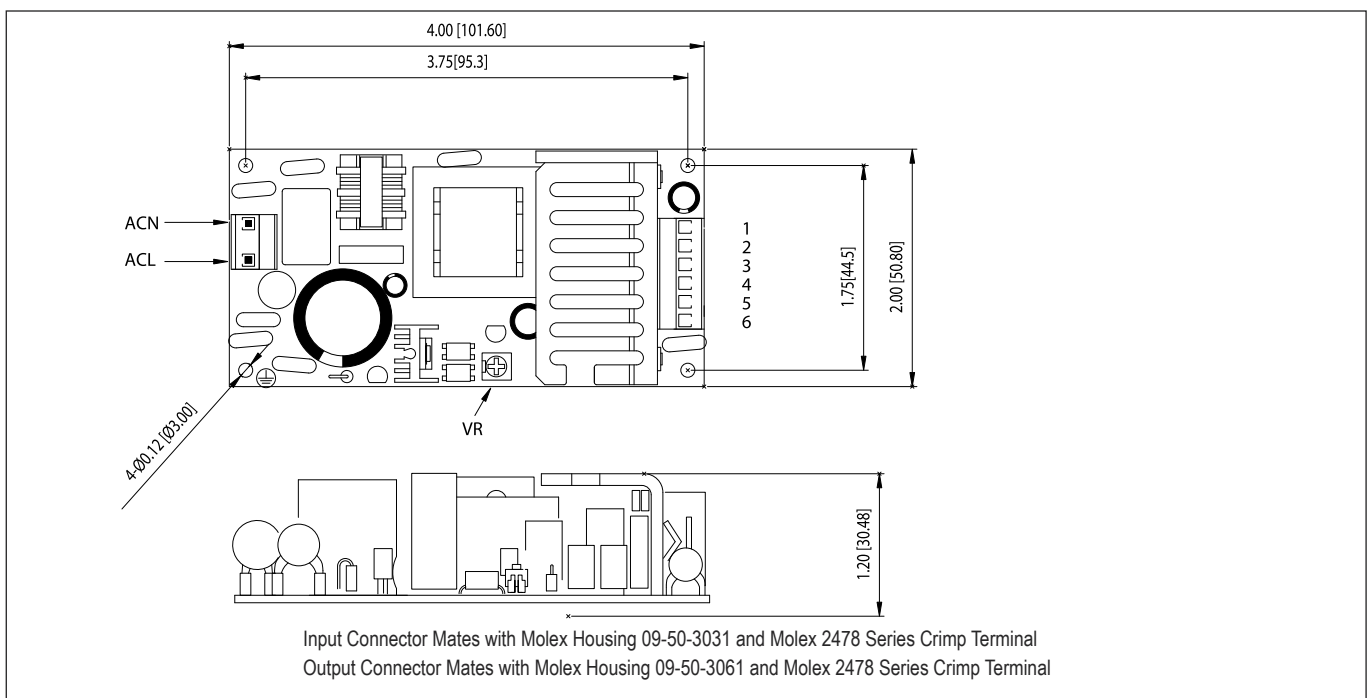

Pin Connection (ZPD/ZPT)

PIN	Function	PIN	Function
1	V2	2	V1
3	V1	4	COM
5	COM	6	V3

INTERMEDIATE VOLTAGES AVAILABLE
PLEASE CONSULT SALES

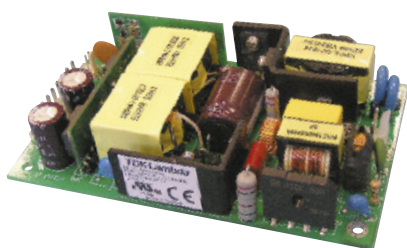

ZPSA100 Series

3" x 5" 100W AC-DC
Power Supplies

- PFC
- Wide Range AC Input
- Low Profile, Industry Standard Footprint
- Global Safety Agency Compliance
- RoHS Compliant

Key Market Segments & Applications

- Video/Audio Routers
- Datacom
- Point of Sale
- Test and Measurement
- LED Information Displays

ZPSA100 Features and Benefits

Features

- Industry Standard Footprint
- Up to 90% efficiency
- Broad Product Range
- Meets EN61000-4 Immunity
- Low Profile

Benefits

- Available to Second Source
- Less System Heating
- Optimization of Power Supply to System
- Greater Reliability

Specifications

ITEMS		MODEL	ZPSA100
Input Voltage range	-	-	90 - 264VAC (47 - 440Hz) or 120 - 370VDC
Inrush Current	A	A	25 / 50 (cold start)
Input Current (115/230VAC)	A	A	1.1 / 0.6
Temperature Coefficient	-	-	±0.05%/°C
Voltage Accuracy	-	-	±1%
Minimum Load	A	A	None
Load Regulation	-	-	±1%
Line Regulation	-	-	±0.5%
Ripple & Noise	(1)	mV	1% or 50mV whichever is greater
Short Circuit Protection	-	-	Foldback
Overvoltage Protection	V	V	Typically 110-130% of nominal, auto recovery
Hold Up Time (Typ)	ms	ms	16ms at 115VAC input
LED Indicator	-	-	Green LED = OK
Operating Temperature	°C	°C	0 to +70°C with derating/air flow
Storage Temperature	°C	°C	-20 to +85°C
Humidity (non condensing)	-	-	10 - 95% RH
Cooling	(2)	-	Convection/air flow
Withstand Voltage			Input to Ground 1.5kVAC, Input to Output 3kVAC, Output to Ground 500VAC for 1 min.
Isolation Resistance			>100MΩ at 25°C & 70%RH, Output to Ground 500VDC
Vibration (non operating)			23.52m/s ² (10 - 55Hz: constant sweep 1 min X, Y, Z for 1 hour)
Shock	-	-	< 196.1 m/s ² (20G)
Safety Agency Approvals	-	-	UL/CSA/EN60950-1 (2nd Ed) Class I , CE Mark (LVD)
Conducted & Radiated EMI	-	-	EN55022-B, FCC Class B
Immunity	-	-	EN61000-4-2,-3,-4,-6,-8
Weight (Typ)	g	g	385
Size (WxLxH)	mm	mm	127 X 76.2 X 26.6 (including underside components)
Warranty	yrs	yrs	2

Notes:

- (1) 5V measured with 0.1μF ceramic & 220μF electrolytic at 20MHz BW, all other models measured with 0.1μF & 10uF ceramic electrolytic at 20MHz BW.
 (2) 70°C operating with 100LFM air flow.



Model Selector

Model	Output Voltage (V)	Maximum Load (A)	Minimum Load (A)	Ripple and Noise	Voltage Accuracy	Line Regulation	Load Regulation
ZPSA100-5	5V	20A	0A	2%	+/- 1%	+/- 0.5%	+/- 1%
ZPSA100-9	9V	11.2A	0A	1%	+/- 1%	+/- 0.5%	+/- 1%
ZPSA100-12	12V	8.4A	0A	1%	+/- 1%	+/- 0.5%	+/- 1%
ZPSA100-15	15V	6.7A	0A	1%	+/- 1%	+/- 0.5%	+/- 1%
ZPSA100-18	18V	5.6A	0A	1%	+/- 1%	+/- 0.5%	+/- 1%
ZPSA100-24	24V	4.2A	0A	1%	+/- 1%	+/- 0.5%	+/- 1%
ZPSA100-48	48V	2.1A	0A	1%	+/- 1%	+/- 0.5%	+/- 1%

Derating Curve ZPSA100 Series

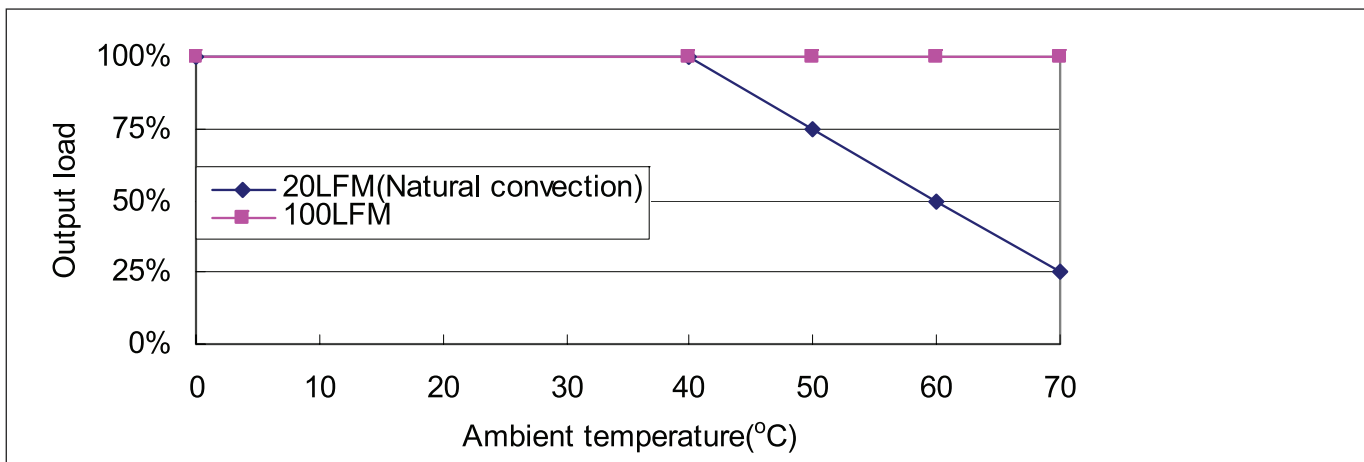

INTERMEDIATE VOLTAGES AVAILABLE
PLEASE CONSULT SALES



Outline Drawing ZPSA100 Series

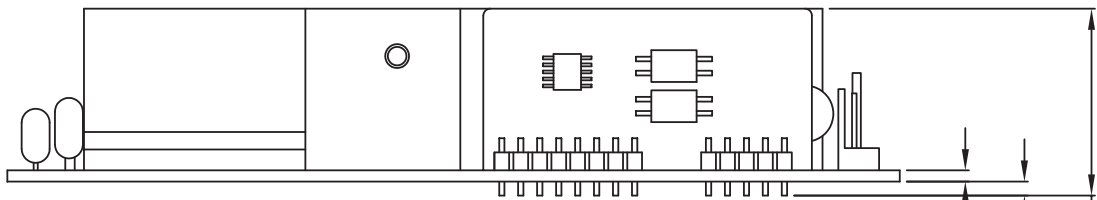
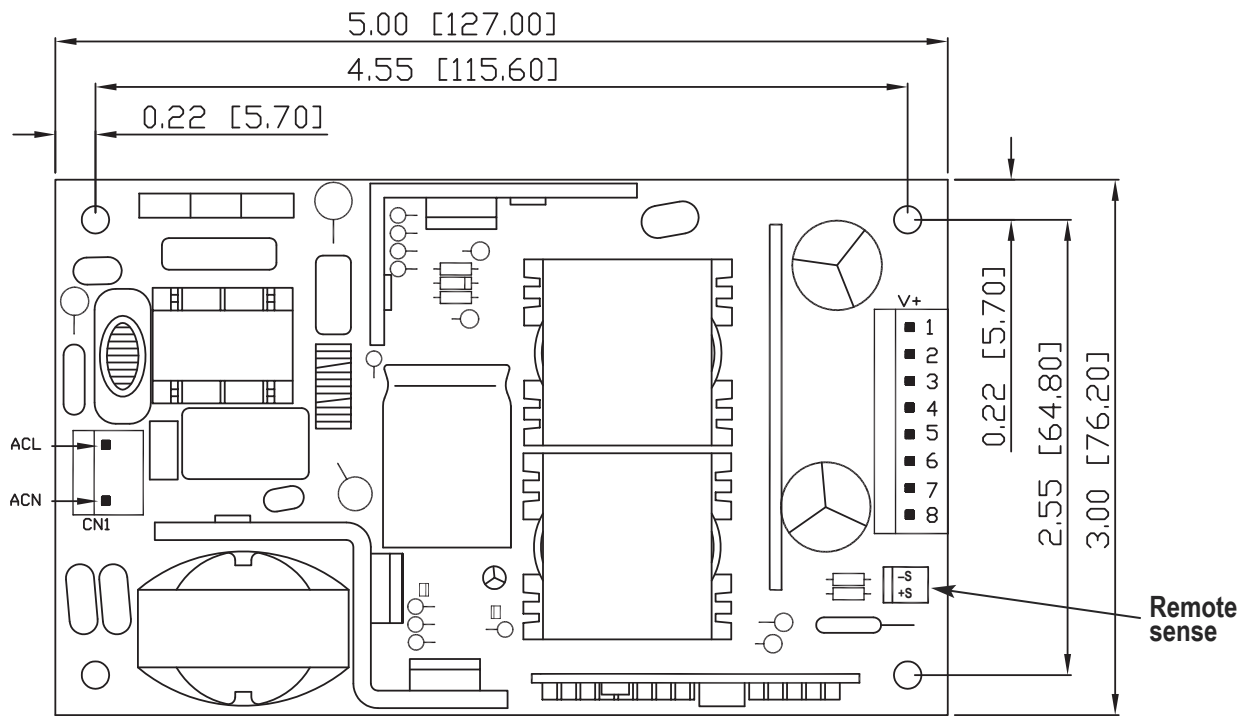

Notes:

All dimensions are in inches (mm)
Tolerances: XX± .02 (XX± .5) unless otherwise noted

PIN Assignments	
Pin#	Function
1	Vout (+)
2	Vout (+)
3	Vout (+)
4	Vout (+)
5	Vout (-)
6	Vout (-)
7	Vout (-)
8	Vout (-)

Input Connector Mates with Molex Housing 09-50-3031 and Molex 2478 Series Crimp Terminal
Output Connector Mates with Molex Housing 09-50-1081 and Molex 5194 Series Crimp Terminal
Sense Connector Mates with Molex Housing 22-01-1022 and Molex 2759 or 5159 Crimp Terminal



- Universal Input (85 - 265VAC)
- Input Transient Protected
- 2 Year Warranty
- High Quality Design
- Peak Power Capability

Key Market Segments & Applications

Factory Automation	Process Control, NC-Machining, Automotive, Packaging Equipment, Materials Handling, Chemical Processing, Robots
Test & Measurement	Burn-in & Test, Automated Test, Instrumentation, Measurement, Detection
Light Industrial	Gaming, Vending, Printers

ZWS Series

Single Output Low Cost, Worldwide Use

ZWS Features and Benefits

Features

- Input Transient Protected
- 2 Year Warranty
- Peak Power Capability

Benefits

- Withstands Harsh Environments
- Lower Cost of Ownership
- Can Drive High current Start Up Devices

Specifications

MODELS		ZWS5 ZWS10	ZWS15 ZWS30	ZWS50
AC Input Voltage range	-	85-265VAC (47-440Hz)		
DC Input Voltage range	-	110 - 330VDC		
Inrush Current (100/200VAC)	(1) A	15 / 30		
Power Factor (Passive)	-	None		
Temperature Coefficient	-	<0.02%/°C		
Overcurrent Protection	(2) -	~125%		
Overvoltage Protection	V	~140% diode clamp		~115 - 130%, manual reset
Hold Up Time (Typ) @ 100VAC	ms	17		
Remote Sense	-	None		
Operating Temperature	-	(open frame) -10°C~+60°C, derate linearly to 70% load from 50°C~60°C		
Operating Temperature	-	(with cover)Additional derating applies, please consult Installation Manual		
Storage Temperature	-	-30 to +85°C		
Humidity (non condensing)	-	10 - 95% RH		
Cooling	-	Convection		
Withstand Voltage	-	Input to Ground 2kVAC (20mA), Input to Output 3kVAC (20mA), Output to Ground 500VAC (100mA) for 1 min.		
Isolation Resistance	-	>100MΩ at 25°C & 70%RH, Output to Ground 500VDC		
Vibration (non operating)	-	10 - 55Hz (1 minute sweep), 19.6m/s ² constant X, Y, Z 1 hour		
Shock	-	< 196.1 m/s ²		
Safety Agency Approvals	-	UL/CSA60950-1, EN60950-1, CE Mark		
Conducted & Radiated	EM	EN55022-B, FCC Class B, VCCI-B		
Weight (Typ)	g	120/120	140/270	370
Size (WxHxD)	mm	See table		
Warranty	yrs	2		

Notes:

(1) 25°C ambient (cold start) (2) Avoid prolonged operation in overload



Model Selector

Model	Voltage	Adjust Range	Max Curr. A	Peak Curr. A	Load Reg mV	Line Reg mV	Ripple Noise mV	Eff. %
ZWS5-3	3.3V	2.97-3.63	1	1.2	40	20	120	62
ZWS10-3	3.3V	2.97-3.63	2	2.4	40	20	120	62
ZWS15-3	3.3V	2.97-3.63	3	3.6	40	20	120	63
ZWS30-3	3.3V	2.97-3.63	6	7.2	40	20	120	70
ZWS50-3	3.3V	2.97-3.63	10	12	40	20	120	73
ZWS5-5	5V	4.5-5.5	1	1.2	40	20	120	67
ZWS10-5	5V	4.5-5.5	2	2.4	40	20	120	70
ZWS15-5	5V	4.5-5.5	3	3.6	40	20	120	71
ZWS30-5	5V	4.5-5.5	6	7.2	40	20	120	75
ZWS50-5	5V	4.5-5.5	10	12	40	20	120	77
ZWS5-12	12V	10.8-13.2	0.42	0.51	96	48	150	68
ZWS10-12	12V	10.8-13.2	0.85	1.02	96	48	150	70
ZWS15-12	12V	10.8-13.2	1.25	1.5	96	48	150	71
ZWS30-12	12V	10.8-13.2	2.5	3	96	48	150	77
ZWS50-12	12V	10.8-13.2	4.3	5.16	96	48	150	80
ZWS5-15	15V	13.5-16.5	0.34	0.41	120	60	150	68
ZWS10-15	15V	13.5-16.5	0.7	0.84	120	60	150	71
ZWS15-15	15V	13.5-16.5	1	1.2	120	60	150	71
ZWS30-15	15V	13.5-16.5	2	2.4	120	60	150	77
ZWS50-15	15V	13.5-16.5	3.5	4.2	120	60	150	81
ZWS5-24	24V	21.6-26.4	0.22	0.27	150	96	200	70
ZWS10-24	24V	21.6-26.4	0.45	0.54	150	96	200	71
ZWS15-24	24V	21.6-26.4	0.65	0.78	150	96	200	71
ZWS30-24	24V	21.6-26.4	1.3	1.56	150	96	200	78
ZWS50-24	24V	21.6-26.4	2.1	2.52	150	96	200	82
ZWS30-36	36V	32.4-39.6	0.9	1.08	240	144	300	78
ZWS50-36	36V	32.4-39.6	1.4	1.68	240	144	300	82
ZWS30-48	48V	43.2-52.8	0.7	0.84	300	192	400	78
ZWS50-48	48V	43.2-52.8	1.1	1.32	300	192	400	82

Note for Peak Current: For 10s maximum, 35% duty cycle, average power not to exceed maximum ratings.

Options

Suffix	Description
Blank	Molex Terminals
/A	Cover option
/J	JST Connectors
/JA	JST Connectors & Cover

Dimension Table (mm)

	Width (W)	Height (H)	Depth (D)
ZWS5	45	21	98
ZWS10	50	21	105
ZWS15	50	21	125
ZWS30	55	26	133
ZWS50	55	26	195

Outline Drawing ZWS5 Series

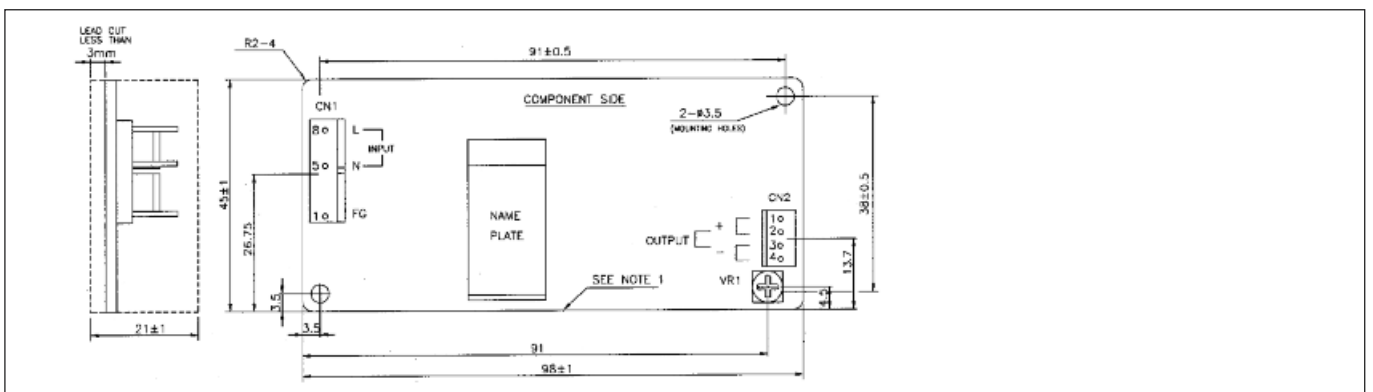



Outline Drawing ZWS10 Series

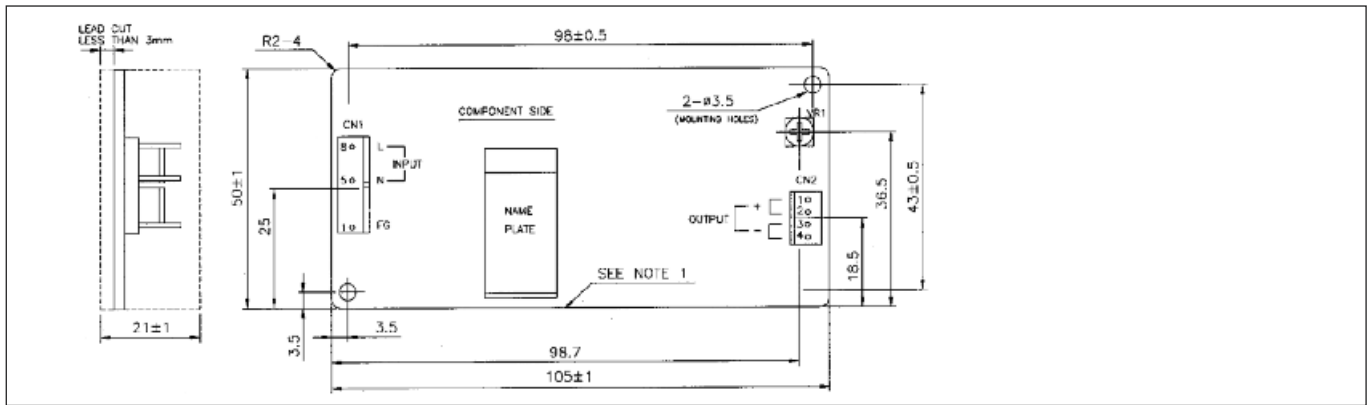

Outline Drawing ZWS15 Series

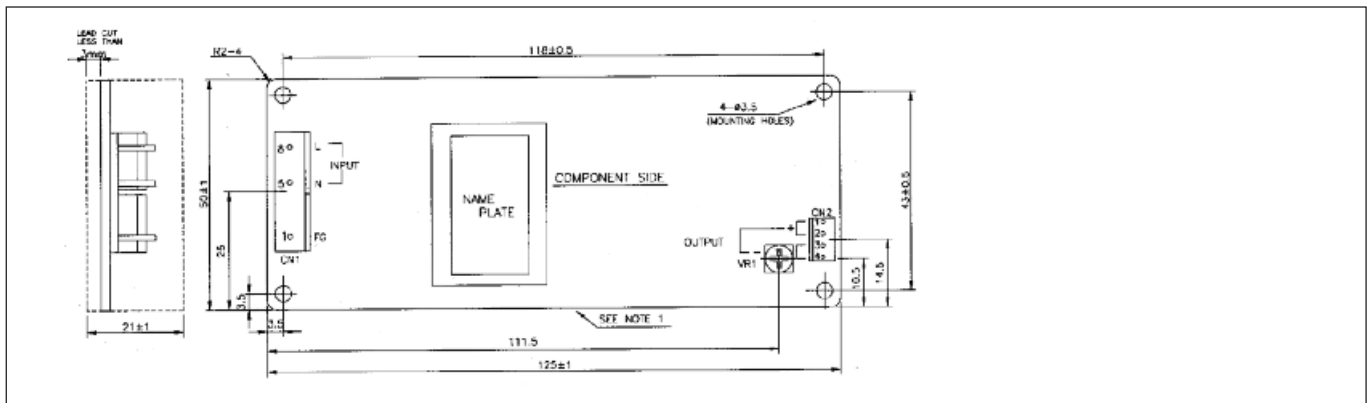

Outline Drawing ZWS30 Series

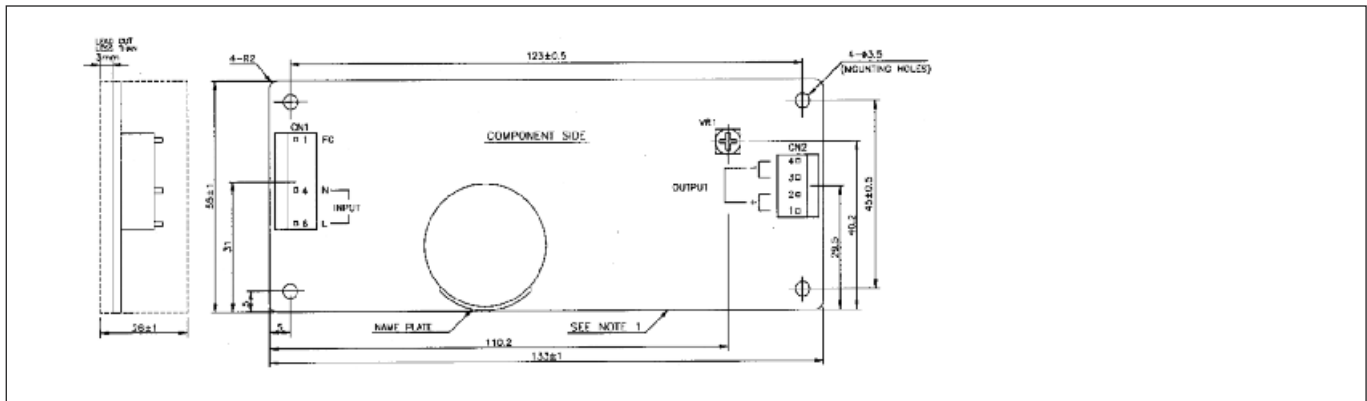

Outline Drawing ZWS50 Series

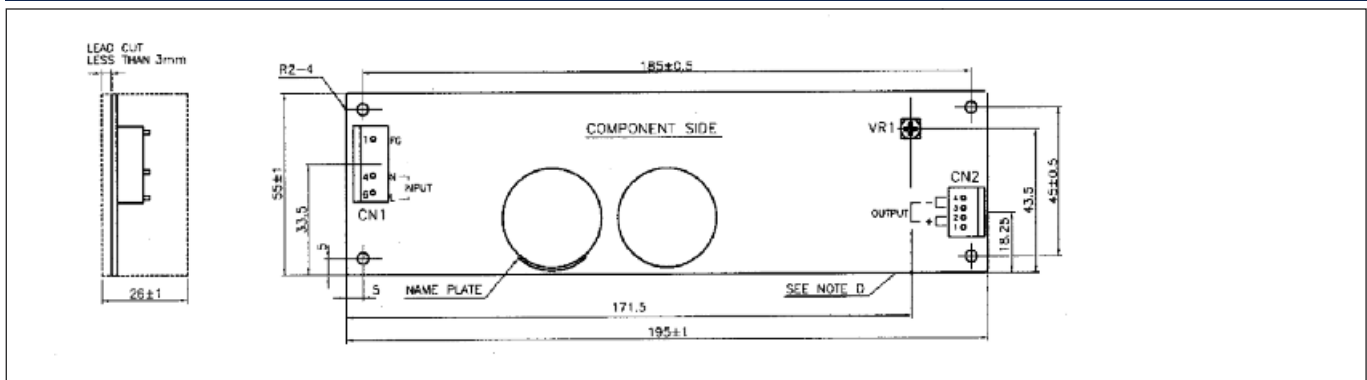



- Universal Input (85 - 265VAC)
- Power Factor Corrected
- Convection Cooled
- 5 year warranty
- Compact Design

Key Market Segments & Applications

- Factory Automation
- Test & Measurement
- Light Industrial Equipment

ZWS-BAF Series

50W to 150W Single Output Power Supplies,
Low Cost, Worldwide Use

ZWS-BAF Features and Benefits

Features

- Convection Cooled
- 5 Year Warranty
- Power Factor Corrected

Benefits

- Better Field Reliability
- Lower Cost of Ownership
- Supports Global Use

Specifications

MODELS		ZWS50BAF	ZWS75BAF	ZWS100BAF	ZWS150BAF
ITEMS					
AC Input Voltage range	-	85-265VAC (47-63Hz)			
DC Input Voltage range	-	120 - 370VDC			
Input Current (Typical) (2)	A	0.45 / 0.25	1.0 / 0.5	1.3 / 0.65	1.9 / 0.95
Inrush Current (2)	A	14 / 28 25°C ambient, cold start			
Power Factor (Active)	-	Meets EN61000-3-2 (Typically 0.98/0.93)			
Maximum Ripple and Noise	mV	3.3 & 5V: 120mV, 12 to 24V: 150mV, 48V: 200mV			
Temperature Coefficient	-	<0.02%/°C			
Overcurrent Protection (1)	-	>105% of maximum output current			
Hold Up Time (Typ) at 100VAC	ms	20ms			
Leakage Current	-	0.5mA max, 0.4mA typ at 230VAC			
Remote On / Off	-	Optional			
Operating Temperature (Convection)	-	-10 to +70°C, derate linearly to 50% load from 50 to 70°C			
Operating Temperature (Forced Air)	-	-10 to +70°C, derate linearly to 75% load from 60 to 70°C			
Storage Temperature	°C	-30 to +75°C			
Humidity (non condensing)	-	Operating: 30 - 90%RH, storage: 10 - 90%RH			
Withstand Voltage	-	I/P to Grnd 2kVAC (10mA), I/P to O/P 3kVAC (10mA), O/P to Grnd 500VAC (20mA) for 1 min.			
Isolation Resistance	-	>100MΩ at 25°C & 70%RH, Output to Ground 500VDC			
Vibration (non operating)	-	10 - 55Hz (1 minute sweep), 19.6m/s ² constant X, Y, Z 1 hour			
Shock	-	< 196.1 m/s ²			
Safety Agency Certifications	-	UL60950-1, CSA60950-1, EN60950-1, EN50178 (OV II), CE Mark			
Conducted & Radiated EMI	-	EN55011/EN55022-B, FCC-B, VCCI-B			
Immunity	-	IEC61000-4-2 (lv 2,3), -3 (lv3), -4 (lv 3), 50/75W: -5 (lv4); 100/150W: -5 (lv 3,4), -6 (lv 3), -8 (lv 4), -11			
Weight (Typ)	g	165	230	290	390
Size (W x H x D)	mm	50 x 26 x 132	50 x 33 x 150	62 x 33 x 155	75 x 37 x 160
Warranty	yrs	5			

Notes:

(1) Avoid prolonged operation in overload (2) 100 / 200VAC Input



Model Selector

Model	Output Voltage	Output Adjust Range (V)	Max Current (A)	Max Output Power(W)	Efficiency (typ) %	Load Reg (mV)	Line Reg (mV)	OVP (V)
ZWS50BAF-3	3.3V	2.97-3.63	10	33	79	40	20	3.8-4.95
ZWS50BAF-5	5V	4.5-5.5	10	50	84	40	20	5.75-7
ZWS50BAF-12	12V	10.8-13.2	4.3	51.6	85	96	48	13.8-16.2
ZWS50BAF-15	15V	13.5-16.5	3.5	52.5	86	120	60	17.3-20.3
ZWS50BAF-24	24V	21.6-26.4	2.1	50.4	87	150	96	27.6-32.4
ZWS50BAF-48	48V	43.2-52.8	1.1	52.8	87	240	192	55.2-64.8
ZWS75BAF-3	3.3V	2.97-3.63	15	49.5	79	40	20	3.8-4.95
ZWS75BAF-5	5V	4.5-5.5	15	75	84	40	20	5.75-7
ZWS75BAF-12	12V	10.8-13.2	6.3	75	85	96	48	13.8-16.2
ZWS75BAF-15	15V	13.5-16.5	5	75	86	120	60	17.3-20.3
ZWS75BAF-24	24V	21.6-26.4	3.2	76.8	87	150	96	27.6-32.4
ZWS75BAF-48	48V	43.2-52.8	1.6	76.8	88	240	192	55.2-64.8
ZWS100BAF-3	3.3V	2.97-3.63	20	66	84	40	20	3.79-4.95
ZWS100BAF-5	5V	4.5-5.5	20	100	86	40	20	5.75-7
ZWS100BAF-12	12V	10.8-13.2	8.5	102	88	96	48	13.8-16.2
ZWS100BAF-15	15V	13.5-16.5	6.7	100.5	88	120	60	17.3-20.3
ZWS100BAF-24	24V	21.6-26.4	4.3	103.2	89	150	96	27.6-32.4
ZWS100BAF-48	48V	39.5-52.8	2.1	100.8	90	240	192	55.2-64.8
ZWS150BAF-3	3.3V	2.97-3.63	30	99	84	40	20	3.79-4.95
ZWS150BAF-5	5V	4.5-5.5	30	150	87	40	20	5.75-7
ZWS150BAF-12	12V	10.8-13.2	12.5	150	88	96	48	13.8-16.2
ZWS150BAF-15	15V	13.5-16.5	10	150	89	120	60	17.3-20.3
ZWS150BAF-24	24V	21.6-26.4	6.3	151.2	90	150	96	27.6-32.4
ZWS150BAF-48	48V	39.5-52.8	3.2	153.6	91	240	192	55.2-64.8

Note: ZWS50 & 75 available Q1 2011

Outline Drawing ZWS50BAF

LEAD CUT LESS THAN 3mm

NAME PLATE

SCALE FOR NAME PLATE : 2/1

CONNECTORS USED:

PART DESCRIPTION	PART NAME	MANUFACT.	QTY
PIN HEADER (INPUT SIDE CN1)	B3P5-VH	J.S.T.	1
PIN HEADER (OUTPUT SIDE CN51)	B4P-VH	J.S.T.	1

*OUTPUT CURRENT OF EACH CONNECTOR PIN MUST BE LESS THAN 5A.

MATCHING HOUSINGS, PINS & TOOL (NOT INCLUDED WITH THE PRODUCT):

PART DESCRIPTION	PART NAME	MANUFACT.	QTY
SOCKET HOUSING (CN1)	VHR-5N	J.S.T.	1
SOCKET HOUSING (CN51)	VHR-4N	J.S.T.	1
TERMINAL PINS	SVH-21T-P1.1	J.S.T.	7
	BVH-21T-P1.1	J.S.T.	7
HAND CRIMPING TOOL	YC-160R	J.S.T.	-

Notes:

- A: 4 - 3.5mm Ø holes are for customers chassis mounting holes. All must be screwed in order to conform the vibration specification.
- B: Model name, input voltage range, nominal output voltage and maximum output current are shown here in accordance with the specifications.
- C: Country of manufacture will be shown here.
- D: ⊥ is for safety ground connection.
- E: To keep the distance more than 4mm between PCB edge and customer's chassis.



Outline Drawing ZWS75BAF

NAME PLATE (SEE NOTE B)

SCALE FOR NAME PLATE : 2/1

CONNECTORS USED:

PART DESCRIPTION	PART NAME	MANUFACT.	QTY
PIN HEADER (INPUT SIDE CN1)	B3P5-VH	J.S.T.	1
PIN HEADER (OUTPUT SIDE CN51)	B6P-VH	J.S.T.	1

MATCHING HOUSINGS, PINS & TOOL (NOT INCLUDED WITH THE PRODUCT):

PART DESCRIPTION	PART NAME	MANUFACT.	QTY
SOCKET HOUSING (CN1)	VHR-5N	J.S.T.	1
SOCKET HOUSING (CN51)	VHR-6N	J.S.T.	1
TERMINAL PINS	SVH-21T-P1.1	J.S.T.	9
	BVH-21T-P1.1	J.S.T.	1
HAND CRIMPING TOOL	YC-160R	J.S.T.	-

Notes:

A: 4 - 3.5mm \varnothing holes are for customers chassis mounting holes. All must be screwed in order to conform the vibration specification.

B: Model name, input voltage range nominal output voltage and maximum output current are shown here in accordance with the specifications.

C: Country of manufacture will be shown here. \downarrow is for safety ground connection.

E: To keep the distance more than 4mm between PCB edge and customer's chassis.

Outline Drawing ZWS100BAF

NAME PLATE (SEE NOTE B)

SCALE FOR NAME PLATE : 2/1

CONNECTORS USED:

PART DESCRIPTION	PART NAME	MANUFACT.	QTY
PIN HEADER (INPUT SIDE CN1)	B3P5-VH	J.S.T.	1
PIN HEADER (OUTPUT SIDE CN51)	B6P-VH	J.S.T.	1

MATCHING HOUSINGS, PINS & TOOL (NOT INCLUDED WITH THE PRODUCT):

PART DESCRIPTION	PART NAME	MANUFACT.	QTY
SOCKET HOUSING (CN1)	VHR-5N	J.S.T.	1
SOCKET HOUSING (CN51)	VHR-6N	J.S.T.	1
TERMINAL PINS	SVH-21T-P1.1	J.S.T.	11
	BVH-21T-P1.1	J.S.T.	1
HAND CRIMPING TOOL	YC-160R	J.S.T.	-

Notes:

A: 4 - 3.5mm \varnothing holes are for customers chassis mounting holes. All must be screwed in order to conform the vibration specification.

B: Model name, input voltage range nominal output voltage and maximum output current are shown here in accordance with the specifications.

C: Country of manufacture will be shown here. \downarrow is for safety ground connection.

E: To keep the distance more than 4mm between PCB edge and customer's chassis.

F: Remote On/Off Control Connector (CN52): B2B-XH-AM (J.S.T.) Option Matching Housing: XHP-2 (J.S.T.). Matching Terminal: BXH-001T-P0.6 (J.S.T.) or SXH-001T-P0.6 (J.S.T.) Hand Crimping Tool: YC-110R (J.S.T.) or YRS-110 (J.S.T.) Matching Housing & Terminal --- not included with the product.

Outline Drawing ZWS150BAF

NAME PLATE (SEE NOTE B)

SCALE FOR NAME PLATE : 2/1

CONNECTORS USED:

PART DESCRIPTION	PART NAME	MANUFACT.	QTY
PIN HEADER (INPUT SIDE CN1)	B3P5-VH	J.S.T.	1
PIN HEADER (OUTPUT SIDE CN51)	B6P-VH	J.S.T.	1
PIN HEADER (OUTPUT SIDE CN53)	B7P-VH	J.S.T.	1

MATCHING HOUSINGS, PINS & TOOL (NOT INCLUDED WITH THE PRODUCT):

PART DESCRIPTION	PART NAME	MANUFACT.	QTY
SOCKET HOUSING (CN1)	VHR-5N	J.S.T.	1
SOCKET HOUSING (CN51)	VHR-6N	J.S.T.	1
SOCKET HOUSING (CN53)	VHR-7N	J.S.T.	1
TERMINAL PINS	SVH-21T-P1.1	J.S.T.	16
	BVH-21T-P1.1	J.S.T.	1
HAND CRIMPING TOOL	YC-160R	J.S.T.	-

Notes:

A: 4 - 3.5mm \varnothing holes are for customers chassis mounting holes. All must be screwed in order to conform the vibration specification.

B: Model name, input voltage range nominal output voltage and maximum output current are shown here in accordance with the specifications.

C: Country of manufacture will be shown here. \downarrow is for safety ground connection.

E: To keep the distance more than 4mm between PCB edge and customer's chassis.

F: Remote On/Off Control Connector (CN52): B2B-XH-AM (J.S.T.) Option Matching Housing: XHP-2 (J.S.T.). Matching Terminal: BXH-001T-P0.6 (J.S.T.) or SXH-001T-P0.6 (J.S.T.) Hand Crimping Tool: YC-110R (J.S.T.) or YRS-110 (J.S.T.) Matching Housing & Terminal --- not included with the product.

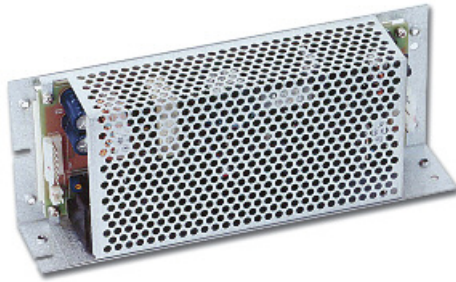

- Universal Input (85 - 265VAC)
- Power Factor Corrected
- 200% Peak Power capability
- 2 Year Warranty
- Less than 0.5mA earth leakage current

Key Market Segments & Applications

Factory Automation	Process Control, NC-Machining, Automotive, Packaging Equipment, Materials Handling, Chemical Processing, Robots
Test & Measurement	Burn-in & Test, Automated Test, Instrumentation, Measurement, Detection
Light Industrial	Gaming, Vending, Printers

ZWS-PAF Series

150W to 480W

Single Output Power Supplies

ZWS-PAF Features and Benefits

Features

- Input Transient Protected
- Power Factor Corrected
- 200% Peak Power Capability

Benefits

- Withstands Harsh Environments
- Supports Global Use
- Can Drive High current Start Up Devices

Specifications

MODELS		ZWS150PAF	ZWS240PAF
ITEMS		85-265VAC (47-63Hz), 120-370VDC	
Input Voltage		85-265VAC (47-63Hz), 120-370VDC	
Input Current (Forced air) (1)	A	2.8/1.4	4.0/2.0
Inrush Current (1,2)	A	14 / 28	
Power Factor		0.99 at 100VAC, 0.95 at 200VAC, Meets EN61000-3-2	
Leakage Current	mA	0.5mA Max. Typically 0.1mA (100VAC), 0.22mA (230VAC)	
Temperature Coefficient		<0.02%/°C	
Overcurrent Protection (3)	-	>102% of peak current capability	
Overvoltage Protection	V	24V: 30-35V, 36V: 43.2-50.4, 48V: 55.2-64.8V	
Hold Up Time (Typ) at 100VAC	ms	20 (16ms at forced air power ratings)	
Efficiency	%	82	
Remote On/Off		See installation manual (Not available with /A cover option)	
Line Regulation	%	0.4%	
Load Regulation	%	0.8%	
Ripple & Noise	%	1%	
Operating Temperature (4)		(Open frame or L bracket) -10°C to +70°C, derate linearly to 70% load from 60°C to 70°C	
Operating Temperature (4)		(With /A cover option) -10°C to +60°C, derate linearly to 70% load from 50°C to 60°C	
Storage Temperature		-30°C to +85°C	
Humidity (non condensing)		Operating: 30 - 90% RH, Operating: 10 - 95% RH	
Cooling		Convection or Forced Air Cooled (1.5m/s)	
Withstand Voltage		Input to Ground 2kVAC (20mA), Input to Output 3kVAC (20mA), Output to Ground 500VAC (100mA) for 1 min.	
Isolation Resistance		>100MΩ at 25°C & 70% RH, Output to Ground 500VDC	
Vibration (non operating)		10 - 55Hz (1 minute sweep), 19.6m/s ² constant X, Y, Z 1 hour	
Shock		< 196.1 m/s ²	
Safety Agency Approvals		UL/CSA60950-1, EN60950-1, EN50178, CE Mark	
Conducted & Radiated EMI		EN55022/EN55022-B, FCC Class B, VCCI-B	
Recommended EMI Filter		MAW1205-22	
Immunity		EN61000-4-2, -3, -4, -5, -6, -8, -11	
Weight (Typ)	g	500g (800g with cover)	750g (1100g with cover)
Size (WxHxD) (PCB versions)	mm	208 x 80 x 40	222 x 95 x 45 (5)
Warranty	yrs	2	

Notes:

- | | | |
|-------------------------------|--|--|
| (1) 100/200VAC | (3) Avoid prolonged operation in overload | (5) See outline drawings for all other models on website |
| (2) 25°C ambient (cold start) | (4) With 0.7m/s airflow. See derating table for convection cooling | |



Model Selector

Model	Voltage	Max Adjust Range	Max Current Convection	Max Power Convection	Max Current Forced Air(6)	Power Forced Air(6)	Peak Current(5)	Peak Power(5)
ZWS150PAF24	24V	21.6 - 28.8V	6.3A	151.2W	8.4A	201.6W	12A	288W
ZWS150PAF36	36V	32.4 - 41.4V	4.2A	151.2W	5.6A	201.6W	8A	288W
ZWS150PAF48	48V	43.2 - 52.8V	3.1A	148.8W	4.3A	206.4W	6A	288W
ZWS240PAF24	24V	21.6 - 28.8V	10A	240W	12.5A	300W	20A	480W
ZWS240PAF36	36V	32.4 - 41.4V	6.7A	241.2W	8.4A	302.4W	13.3A	478.8W
ZWS240PAF48	48V	43.2 - 52.8V	5A	240W	6.3A	302.4W	10A	480W

Note 5: For 10s maximum, 35% duty cycle, average power not to exceed maximum ratings

Note 6: With 1.5m/s forced air

Model Derating for Convection Cooling

Model	25°C	30°C	35°C	40°C	45°C	50°C	55°C	60°C
ZWS150PAF**	100%	100%	100%	100%	100%	100%	85%	70%
ZWS150PAF**/A	100%	100%	90%	80%	72.5%	65%	-	-
ZWS240PAF**	100%	100%	100%	100%	100%	86.7%	73.3%	60%
ZWS240PAF**/A	100%	90%	80%	70%	60%	50.0%	-	-

Outline Drawing ZWS150PAF

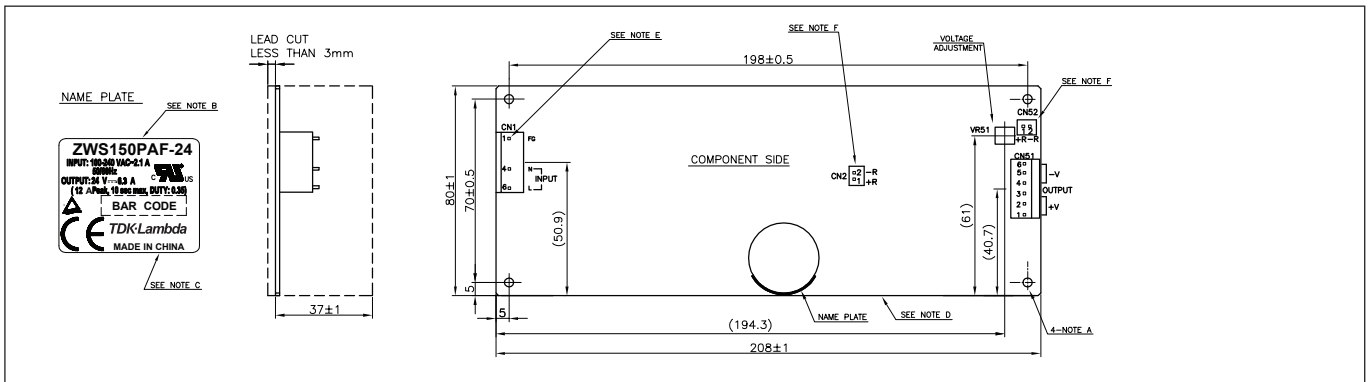

Outline Drawing ZWS150PAF/TL

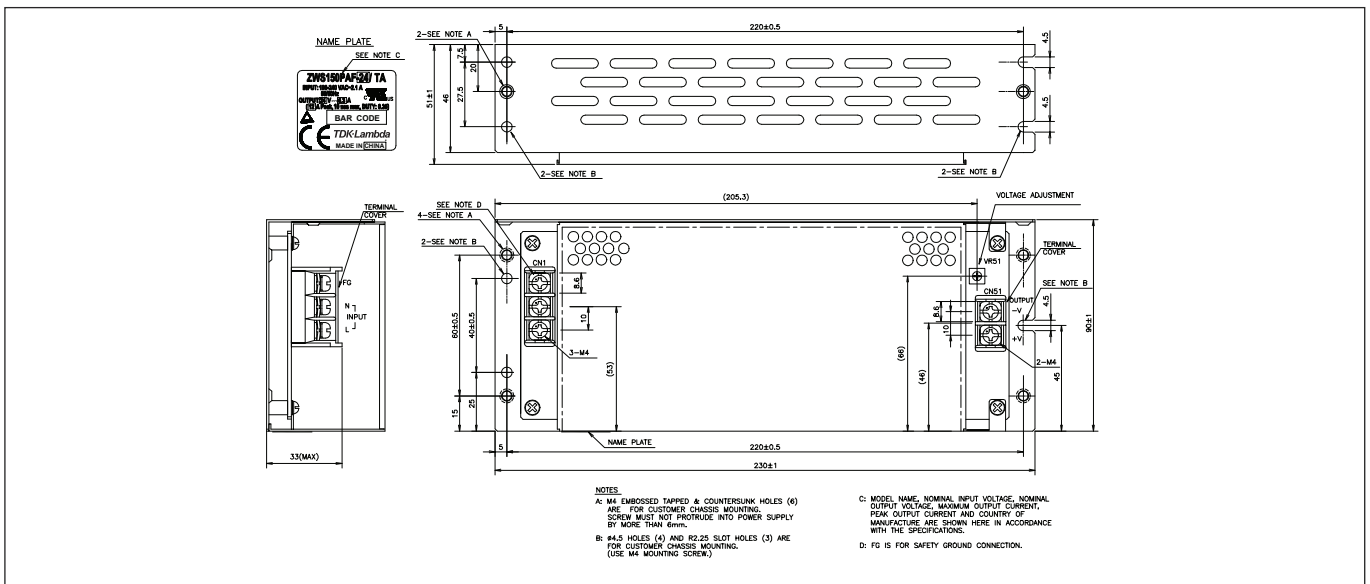

NOTES
 A: M4 EMBOSSED TAPPED & COUNTERSINK HOLES (6) ARE FOR CUSTOMER CHASSIS MOUNTING. SCREW MUST NOT PROTRUDE INTO POWER SUPPLY BY MORE THAN 0.5mm.
 B: #4.5 HOLES (4) AND R2.25 SLOT HOLES (3) ARE FOR CUSTOMER CHASSIS MOUNTING. (USE M4 MOUNTING SCREWS)
 C: MODEL NAME, NOMINAL INPUT VOLTAGE, NOMINAL OUTPUT VOLTAGE, MAXIMUM OUTPUT CURRENT, PEAK OUTPUT CURRENT AND COUNTRY OF MANUFACTURE ARE SHOWN HERE IN ACCORDANCE WITH THE SPECIFICATIONS.
 D: FG IS FOR SAFETY GROUND CONNECTION.



Outline Drawing ZWS240PAF

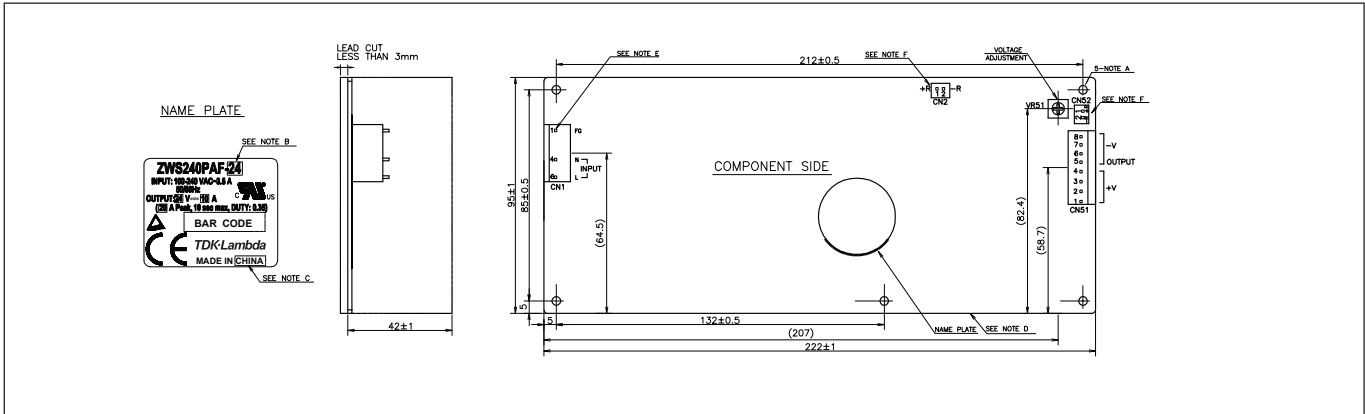

Outline Drawing ZWS240PAF/TL

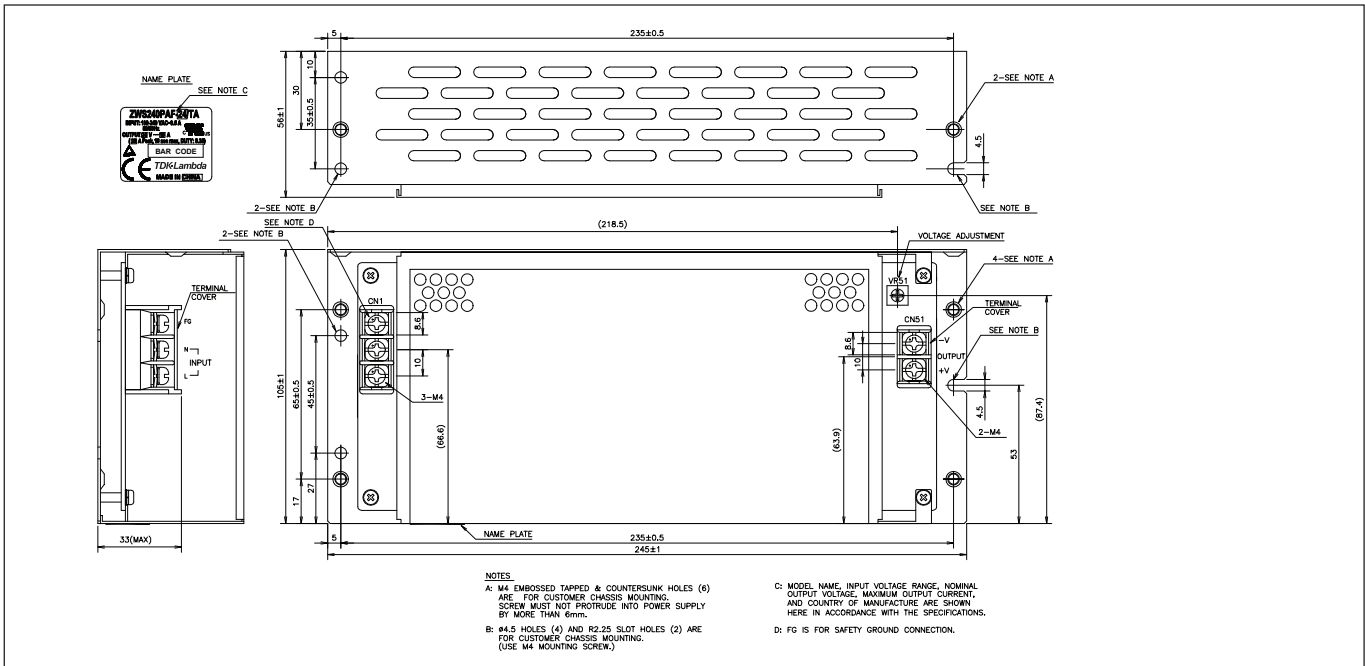

Options

Suffix

Option

Blank	Molex Input & Output Connectors
/L	L Bracket
/A	Cover and L Bracket
/J	JST Input & Output Connectors
/T	Vertical Mount Screw Terminals
/S	Horizontal Mount Screw Terminals

Preferred option combinations:

Blank, /L, /TL or /TA. Example: ZWS240PAF24/TA

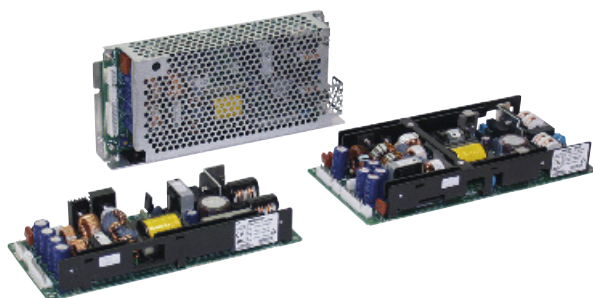

- Universal Input (85 - 265VAC)
- Power Factor Corrected
- Floating Adjustable Fourth Output
- Low Profile <1U High

ZWQ Series

80W to 170W

Quad Output Power Supplies

Key Market Segments & Applications

- Factory Automation
- Test & Measurement
- Light Industrial Equipment

ZWQ Features and Benefits

Features

- Low Profile
- Adjustable Main and Fourth Output
- Power Factor Corrected
- Floating Fourth Output

Benefits

- Fits in 1U Enclosures
- System Optimization
- Supports Global Use
- Can be used as Positive or Negative Output

Specifications

Items	Models		ZWQ80 -5222	ZWQ80 -5223	ZWQ80 -5224	ZWQ80 -5225	ZWQ130 -5222	ZWQ130 -5223	ZWQ130 -5224	ZWQ130 -5225
Input Voltage	-		85-265VAC (47-63Hz), 120-370VDC							
Input Current	(1)	A	1.6 / 0.8				2.6 / 1.3			
Inrush Current	(1)	A	14/28							
Power Factor	-		Meets EN61000-3-2							
Temperature Coefficient	-		<0.02%/°C							
Max Output Power (convection)	W		80				130			
Max Output Power (forced air)	W		104	88.7	104	104	170	149.6	170	170
Overpower Protection	(2)	W	>109	>93	>109	>109	>173	>152	>173	>173
Minimum Load	A		V1: 0.9A Conv, 1.4A Forced Air				V1: 1.5A Conv, 2.1A Forced Air			
Output Voltage Accuracy	%		±5% for outputs V2 and V3							
Efficiency (Typ)	%		72							
Hold Up Time	(1)	ms	20							
Leakage Current	-		0.75mA max, 0.2mA (Typ) at 100VAC / 0.44mA(Typ) at 230VAC							
Remote On / Off	-		See installation manual (Not available with /A cover option)							
Oper Temp (convection cooled)	-		-10°C to 60°C, derate linearly to 50% load from 40°C to 60°C. (3)							
Oper Temp (forced air cooled)	-		-10°C to 70°C, derate linearly to 50% load from 50°C to 70°C. (>30cfm airflow) (3)							
Storage Temperature	-		-30°C to +85°C							
Humidity (non condensing)	-		Operating: 30 - 90% RH; Non-operating 10-95% RH							
Withstand Voltage	-		I/P~Gnd 2kVAC (20mA), I/P~O/P 3kVAC (20mA), O/P~Gnd 500VAC (100mA) for 1 min.							
Isolation Resistance	-		>100MΩ at 25°C & 70%RH, Output to Ground 500VDC							
Vibration (non operating)	-		10 - 55Hz (1 minute sweep), 19.6m/s ² constant X, Y, Z 1 hour							
Shock	-		< 196.1 m/s ²							
Safety Agency Approvals	-		UL/CSA60950-1, EN60950-1, CE Mark, EN50178							
Conducted & Radiated EMI	-		EN55011, EN55022-B, FCC Class B, VCCI-B							
Immunity	-		EN61000-4-2,-3,-4,-5,-6,-8,-11							
Weight (Typ)	g		550				730			
Size (W x H x D)	mm		93.5 x 35 x 210				106 x 35 x 225			
Warranty	yr		1							

Notes:

(1) 100/200VAC

(2) Avoid prolonged operation in overload

(3) /A version - additional derating - See installation manual



Model Selector									
MODEL	Output	Voltage (V)	Voltage Adjust Range (V)	Convect. (A)	Peak or Forced Air (A)(4)	Max Load Reg (mV)	Max Line Reg (mV)	Ripple Noise (mV)	OVP (V)(5)
ZWQ80-5222	V1	5	5.0-5.25	8.0	10.0	100	20	120	5.7-7.0
	V2	+12/15*	+12/+15	2.0	2.5	300	48	150	16.5-22.5
	V3	-12/15*	-12/-15	2.0	2.5	300	48	150	16.5-22.5
	V4	12	11.4-12.6	3.0	4.0	300	48	150	13.8-16.2
ZWQ80-5223	V1	5	5.0-5.25	8.0	10.0	100	20	120	5.7-7.0
	V2	+12/15*	+12/+15	2.0	2.5	300	48	150	16.5-22.5
	V3	-12/15*	-12/-15	2.0	2.5	300	48	150	16.5-22.5
	V4	3.3	2.0-3.63	7.0	9.0	100	20	120	3.79-4.95
ZWQ80-5224	V1	5	5.0-5.25	8.0	10.0	100	20	120	5.7-7.0
	V2	+12/15*	+12/+15	2.0	2.5	300	48	150	16.5-22.5
	V3	-12/15*	-12/-15	2.0	2.5	300	48	150	16.5-22.5
	V4	24	22.8-25.2	1.5	2.0	400	96	200	27.6-32.4
ZWQ80-5225	V1	5	5.0-5.25	8.0	10.0	100	20	120	5.7-7.0
	V2	+12/15*	+12/+15	2.0	2.5	300	48	150	16.5-22.5
	V3	-12/15*	-12/-15	2.0	2.5	300	48	150	16.5-22.5
	V4	5	2.0-5.25	7.0	9.0	100	20	120	5.7-7.0
ZWQ130-5222	V1	5	5.0-5.25	15.0	19.0	100	20	120	5.7-7.0
	V2	+12/15*	+12/+15	4.0	5.0	300	48	150	16.5-22.5
	V3	-12/15*	-12/-15	4.0	5.0	300	48	150	16.5-22.5
	V4	12	11.4-12.6	4.0	5.0	300	48	150	11.4-12.6
ZWQ130-5223	V1	5	5.0-5.25	15.0	19.0	100	20	120	5.7-7.0
	V2	+12/15*	+12/+15	4.0	5.0	300	48	150	16.5-22.5
	V3	-12/15*	-12/-15	4.0	5.0	300	48	150	16.5-22.5
	V4	3.3	2.0-3.63	10.0	12.0	100	20	120	3.79-4.95
ZWQ130-5224	V1	5	5.0-5.25	15.0	19.0	100	20	120	5.7-7.0
	V2	+12/15*	+12/+15	4.0	5.0	300	48	150	16.5-22.5
	V3	-12/15*	-12/-15	4.0	5.0	300	48	150	16.5-22.5
	V4	24	22.8-25.2	2.0	2.5	400	96	200	27.6-32.4
ZWQ130-5225	V1	5	5.0-5.25	15.0	19.0	100	20	120	5.7-7.0
	V2	+12/15*	+12/+15	4.0	5.0	300	48	150	16.5-22.5
	V3	-12/15*	-12/-15	4.0	5.0	300	48	150	16.5-22.5
	V4	5	2.0-5.25	10.0	12.0	100	20	120	5.7-7.0

* User selectable via connector on PCB. Outputs are floating from V1 & V4

Notes:

- (4) Peak current draw must not exceed 10s duration, duty cycle 35%.
- (5) OVP on any output will shut down all outputs. Recycle AC input to reset.

Options	
Suffix	Description
blank	No cover or L Bracket
/L	L Bracket
/A	Cover and L Bracket



- Wide Range AC Input
- Low profile, Industry Standard Footprint
- Global Safety Agency Compliance

CSS65 Series

2 x 4" 40 to 65W AC-DC
Medical Power Supplies

Key Market Segments & Applications

- Medical
- Gaming
- Test & Measurement

CSS65 Features and Benefits

Features

- Industry standard footprint
- Wide Range AC Input
- Dual input fuses

Benefits

- Availability to second source
- Global Operation
- Easier system compliance

Specifications

ITEMS		CSS65
Input Voltage range	V	90 - 264VAC (47 - 63Hz) or 120 - 370VDC
Inrush Current	A	<40A maximum at 115VAC input, 25oC ambient cold start
Input Current (115/230VAC)	A	2 / 1
Leakage Current	µA	<250uA 264VAC 63Hz
Hold Up Time (Typ)	ms	10ms at 115VAC input
Temperature Coefficient	°C	±0.05%/°C
Adjustment Range	-	None
Remote Sense	-	Yes
Minimum Load	A	None
Regulation	%	5V: ±5%, 12-24V: ±3%, 36-48V: ±2% (10 - 100% load change, 100-240VAC line change)
Ripple & Noise	%	1%
Short Circuit Protection	-	Continuous - hiccup mode
Overvoltage Protection	V	110 - 150% of nominal (Automatic Reset)
Efficiency	%	up to 87% (see Model Selector)
Operating Temperature	°C	0 to +70°C derate linearly to 50% load from 50 to 70°C
Storage Temperature	°C	-10 to +70°C
Humidity (non condensing)	-	20 - 95% RH
Cooling	-	Convection
Withstand Voltage	-	Input to Ground 1.5kVAC, Input to Output 4kVAC, Output to Ground 500VDC for 1 min.
Isolation Resistance	-	>20MΩ at 25°C & 70%RH, Output to Ground 500VDC
Vibration (non operating)	-	23.52m/s ² (10 - 55Hz: constant sweep 1 min X, Y, Z for 1 hour)
Shock	-	< 196.1 m/s ² (20G)
Safety Agency Approvals	-	UL60601-1, EN60601-1, IEC60601-1
Conducted & Radiated EMI	-	EN55011-B, FCC Class B
Immunity	-	EN60601-1-2
Weight (Typ)	g	200g
Size (WxLxH)	mm	51 x 104 x 30 (including underside components)
Warranty	yrs	2

• 150W models coming soon • 12V, 15V, 24V, 36V and 48V outputs • 89% efficiency (typ) • standard 3x5" foot print •
 • IEC/EN/UL60601-1 & IEC/EN/UL60950-1 approvals • wide range AC input •

Available 2011



Model Selector

Model	Output (V)	Maximum Output (A)	Maximum Power (A)	Efficiency % (typ)
CSS65-5	5	8.0	40	81
CSS65-12	12	5.0	60	86
CSS65-15	15	4.0	60	86
CSS65-19	19	3.43	65	86
CSS65-24	24	2.71	65	87
CSS65-36	36	1.81	65	87
CSS65-48	48	1.36	65	87

Outline Drawing CSS65 Series

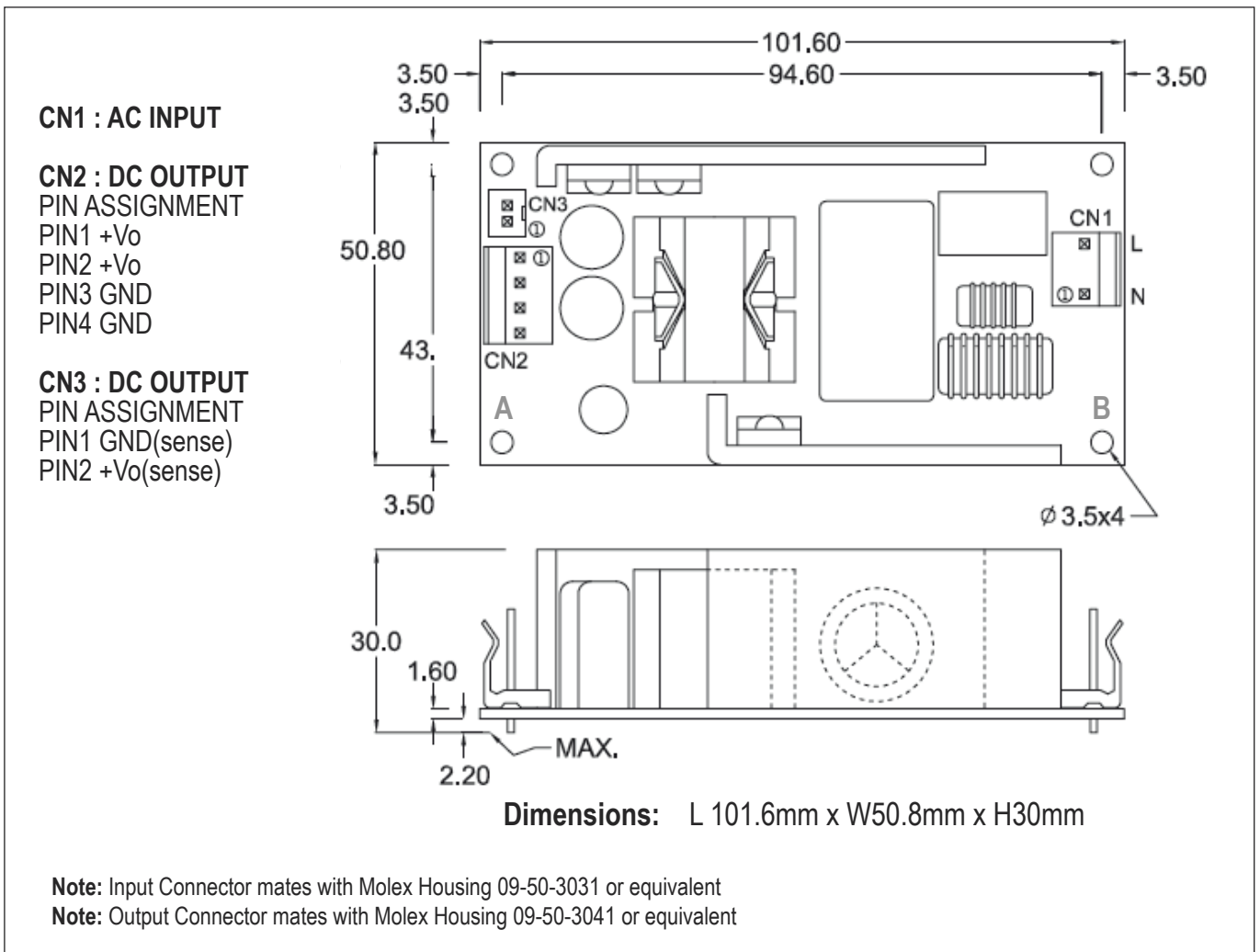

Earthing points: The CSS65 is a Class I product. When installing the CSS65, fixing points **A** & **B** must be securely connected to a protective earth in the final system assembly.

Fusing: Internal fuses (F1 & F2): The product is dual fused in the L and N line, T3.15A, 250V. The product is not user serviceable. Fuses must not be replaced by the user.



- High Efficiency
- 5 in x 3 in / 6 in x 3 in footprint
- No minimum load
- Fits 1U applications
- 400/530 Watts peak power for 10 seconds
- 3 Year Warranty

EFE300 / EFE400

300/400 Watts, Ultra High Density
AC-DC, digital power solution

Key Market Segments & Applications

Instrumentation	Broadcast
Automation	ATE
Security	Industrial Computing
Network Servers/Routers	Lifesciences/Laboratory

Features and Benefits

Features	Benefits
<ul style="list-style-type: none"> • Full Digital Control • High Efficiency • Low Profile 	<ul style="list-style-type: none"> • Improves Product Performance • Minimises heat in system • Fits 1U applications

INPUT			
Input Voltage	90 - 264Vac / 120 - 350Vdc	Input Frequency	45 - 63Hz (440Hz with reduced PFC - consult factory)
Input Harmonics	EN61000-3-2 compliant	Power Factor	0.97 typical
Input Fuse	Dual fuses (Live + Neutral) Fast acting (not user accessible)	Inrush Current at 25°C and 230Vac	<20A for EFE300, <30A for EFE400 (cold start) (meets EN61000-3-3)
Earth Leakage Current	410µA at 120Vac (60Hz), 858µA max at 240Vac (60Hz) Worst case leakage current is less than 1.0mA at 264Vac, 63Hz (normal condition, 1.8mA Single Fault Condition)		

QUICK SELECTOR (Standard models). Additional variants available - see below

Output		Units without fan		Units with end fan
		Open Frame	Cover + Chassis	Cover + Chassis
12V / 25A	Description	EFE300-12-CNMD5	EFE300-12-CCMDS	EFE300-12-ECMDS
	Order code	U2Y002G	U2Y001F	U2Y003H
24V / 12.5A	Description	EFE300-24-CNMD5	EFE300-24-CCMDS	EFE300-24-ECMDS
	Order code	U2Y005K	U2Y004J	U2Y006L
12V / 33.3A	Description	EFE400-12-CNMD5	EFE400-12-CCMDS	EFE400-12-ECMDS
	Order code	U4Y002H	U4Y001G	U4Y003J
24V / 16.7A	Description	EFE400-24-CNMD5	EFE400-24-CCMDS	EFE400-24-ECMDS
	Order code	U4Y005L	U4Y004K	U4Y006M

HOW TO CREATE A PRODUCT CODE

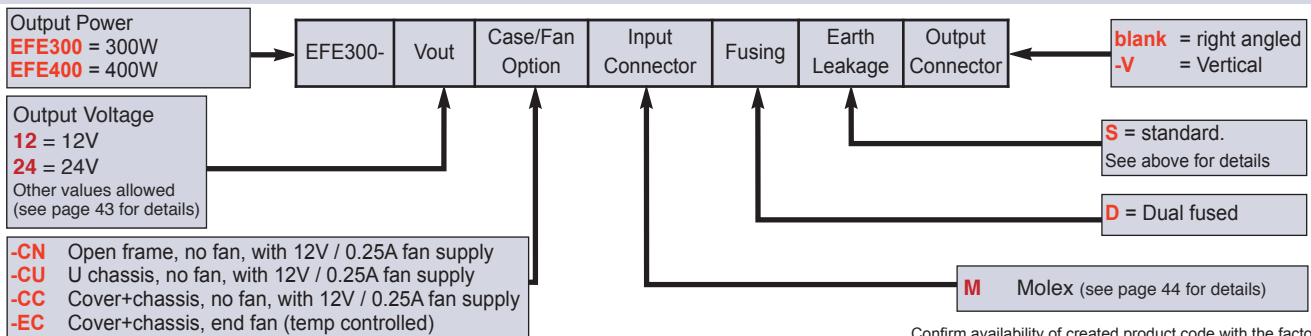



ISOLATION			
Input to Output	Reinforced	3kV (ac), 4.3kV (dc)	
Input to Earth	Basic	1.5kV (ac), 2.3 kV (dc)	Output to Earth 200 V (dc)

OUTPUT SPECIFICATION			
	EFE300	EFE400	
Output Power	300W	400W	Continuous
Peak Power	400W	530W	for 10 seconds (300W RMS for EFE300, 400W RMS for EFE400)
Total Regulation	better than 4% Including Line (for 90-264Vac input change), Load (for 0-100% load change) and temperature (0-50°C)		
Ripple & Noise	1.5%	pk-pk, using EIAJ test method & 20MHz bandwidth	
Voltage Setting Range	+10% / -5% To be specified at time of ordering (chosen in 'Output Voltage' part of product code)		
Voltage Setting Accuracy	±1% at 50% load		
Turn on Time	1.5s typical	at 90 Vac & 100% rated output power	
Efficiency	90%	typical	
Hold up	16ms	typical at 90 Vac, 75% load	
Min Load	None		
Transient Response	<5% of set voltage for 50% load change (in 50µs within the range 25 - 100% load)		
Recovery	<1ms for recovery to 2% of set voltage		
Short circuit protection	Yes	Auto recovery after removal of short circuit	
Over Temperature protection	Yes	Primary - auto recovers, secondary - cycle power to restart	
Over Voltage Protection	Yes	Latching, need to cycle ac to restart unit.	
Fan supply	12V / 250mA	Available if 'no fan' is specified, otherwise used by PSU fan. No access to connector with -CC (cover + chassis) variant.	

ENVIRONMENT	
Temperature	0°C to 50°C operational, -40°C to 70°C storage (max 12 months). Full load, with 2m/s air blown from input to output (approximately 10CFM)
Derating	50°C to 70°C derate each output by 2.5% per °C
Low Temp Startup	-20°C
Humidity	5 - 95% RH non condensing
Shock	±3 x 30g shocks in each plane, total 18 shocks 30g shock = 11ms (+/-0.5msec), half sine Conforms to EN60068-2-27, EN60068-2-47, IEC68-2-27, IEC68-2-47, JIS C0041-1987. Conforms to MIL-STD-810E/F, Method 516.5, Pro I, IV, VI
Vibration	Single axis 10 - 500 Hz at 2g (sweep and endurance at resonance) in all 3 planes Conforms to EN60068-2-6, IEC68-2-6 Conforms to MIL-STD-810E, Method 514.4, Pro I, Cat 1,9
Altitude	-200 to 3,000 metres operational (-200 to 5000m storage/transportation)
Pollution	Degree 2, Material group IIIb

IMMUNITY EN61000-6-2:2005				Criteria
Electrostatic Discharge	EN61000-4-2	Level 4	Air discharge 15kV Contact discharge 8kV Not applicable to open frame units	A
Electromagnetic Field	EN61000-4-3	Level 3	12V/m	A
Fast / Burst Transient	EN61000-4-4	Level 4	ac input tested to 4.4kV dc output tested to 2.2kV	A
Surge Immunity	EN61000-4-5	Level 3	Common mode - 2.2kV Differential - 1.1kV	A
Conducted RF Immunity	EN61000-4-6	Level 3	12V	A
Power Frequency Magnetic Field	EN61000-4-8	Level 4	30A/m	A
Voltage Dips, Variations, Interruptions	EN61000-4-11	Class 3	Criteria B for 5 sec interruption EFE-300, criteria B for 1 cycle interruption	A
Ring Wave	EN61000-4-12	Level 3	Common mode - 2.2kV Differential - 1.1kV	A
Voltage Fluctuations	EN61000-4-14	Class 3		A



EMISSIONS EN61000-6-3:2007, EN60601-1-2:2001

Radiated Electric Field	EN55011, EN55022	(as per CISPR.11/22) Class B, FCC47 part 15 subpart B see application note for details
Conducted Emissions	EN55011, EN55022	(as per CISPR.11/22) Class B, FCC47 part 15 subpart B
Conducted Harmonics	EN61000-3-2	Class A
Flicker	EN61000-3-3	Class C (EFE300 at 100W and above, EFE400 at 200W and above)
		Compliant - d _{max} only

SAFETY APPROVALS

	Date	Amendments	Date	Amendments
EN 60950-1	2006		IEC 60950-1*	2005
UL 60950-1	2007		CSA 22.2 No 60950-1	2007
EN 61010-1	2001		IEC 61010-1*	2007
CE Mark	LV Directive 2006/95/EC (EN60950-1)			
* CB certificate and Report available on request			Check with factory for status of approvals	

OUTLINE & CONNECTION DRAWINGS
(not -V version)

Note connection details and outline drawings for -V (vertical) connector are different. See handbook for details

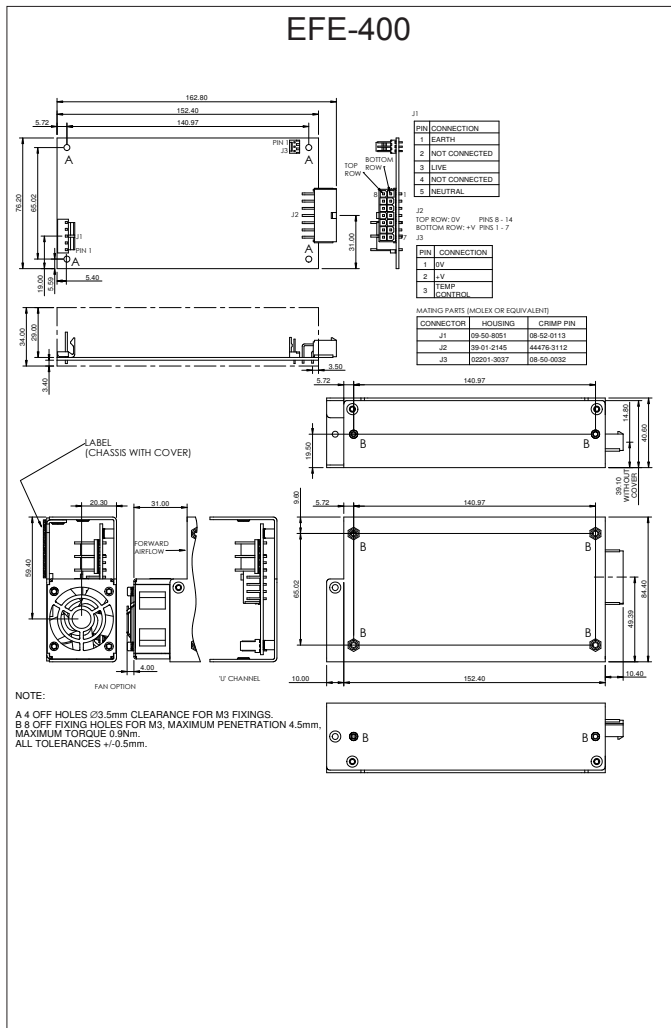
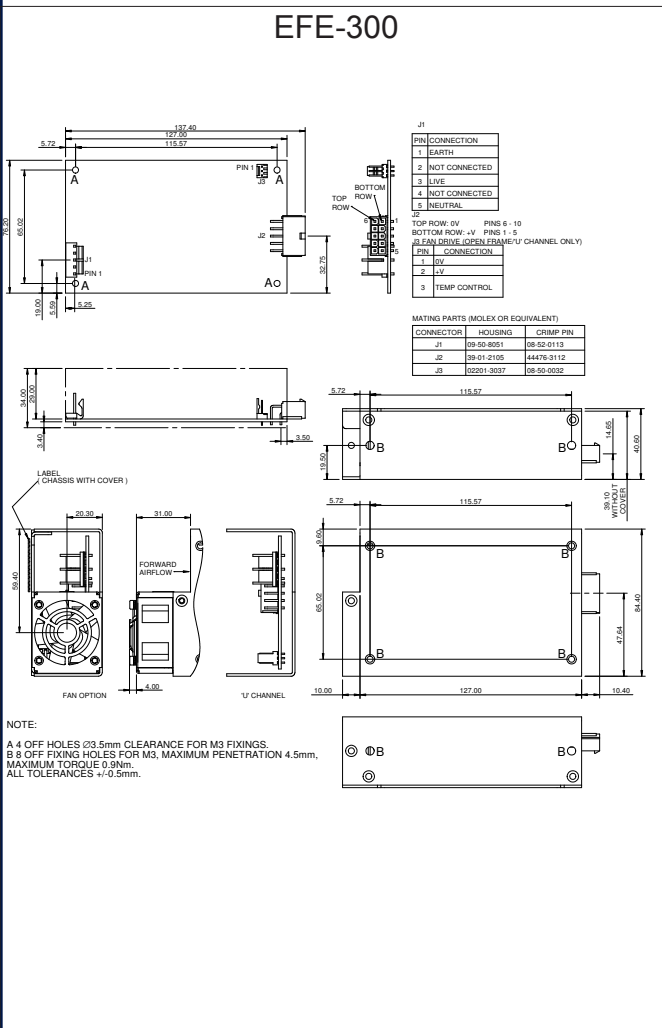

- Notes 1. All customer fixings M3 2. Maximum Penetration 4.5mm 3. Maximum torque 0.9Nm 4. All tolerances +/-0.5mm

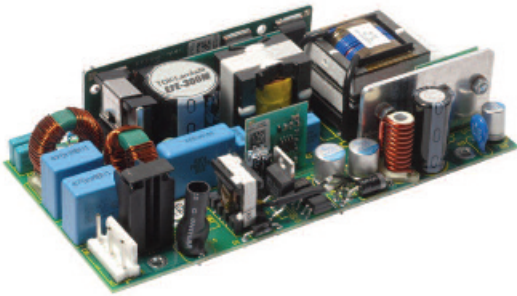

- Designed for Medical Equipment (BF rated)
- High Efficiency
- 300W = 6 in x 3 in footprint, 400W = 6.5 in x 3.5 in
- 1W standby (EFE400M only)
- High Power Density (up to 18W/in³)
- No minimum load
- Fits 1U applications
- 3 Year Warranty

EFE300M / EFE400M

300/400 Watts, medical (BF rated)
AC-DC, digital power solution

Key Market Segments & Applications

Medical	Broadcast
Instrumentation	ATE
Automation	Industrial Computing
Security	Lifesciences/Laboratory
Network Servers and Routers	

Features and Benefits

Features

- Reinforced isolation
- Full Digital Control
- High Efficiency
- Low Profile
- High Power Density
- Temperature controlled fan option

Benefits

- Simplifies equipment design
- Improves Product Performance
- Minimises heat in system
- Fits 1U applications
- Less Space
- Quieter operation

INPUT

Input Voltage	90 - 264Vac / 120 - 350Vdc	Input Frequency	45 - 63Hz (440Hz with reduced PFC - consult factory)
Input Harmonics	EN61000-3-2 compliant	Power Factor	0.97 typical
Input Fuse	Dual fuses (Live + Neutral) Fast acting (not user accessible)	Inrush Current	<40A at 25°C and 230Vac, (cold start) (meets EN61000-3-3)
Earth Leakage Current	123µA at 120Vac (60Hz), 257µA max at 240Vac (60Hz) Worst case leakage current is less than 300µA at 264Vac, 63Hz (normal condition, 0.5mA Single Fault Condition)		

QUICK SELECTOR (Standard models). Additional variants available - see below

Output Voltage	Current	Units without fan				Units with end fan	
		Open Frame		Cover + Chassis		Cover + Chassis	
		Description	Order Code	Description	Order Code	Description	Order Code
12V	25A	EFE300M-12-5-HNMDL-YT	U5Y0020	EFE300M-12-5-HCMDL-YT	U5Y001Z	EFE300M-12-5-ECMDL-YT	U5Y0031
	33.3A	EFE400M-12-5-HNMDL-YT	U6Y001H	EFE400M-12-5-HCMDL-YT	U6Y004L	EFE400M-12-5-ECMDL-YT	U6Y007P
24V	12.5A	EFE300M-24-5-HNMDL-YT	U5Y0053	EFE300M-24-5-HCMDL-YT	U5Y0042	EFE300M-24-5-ECMDL-YT	U5Y0064
	16.7A	EFE400M-24-5-HNMDL-YT	U6Y002J	EFE400M-24-5-HCMDL-YT	U6Y005M	EFE400M-24-5-ECMDL-YT	U6Y008Q
48V	6.25A	EFE300M-48-5-HNMDL-YT	U5Y0201	EFE300M-48-5-HCMDL-YT	U5Y0223	EFE300M-48-5-ECMDL-YT	U5Y0166
	8.3A	EFE400M-48-5-HNMDL-YT	U6Y003K	EFE400M-48-5-HCMDL-YT	U6Y006N	EFE400M-48-5-ECMDL-YT	U6Y009R

HOW TO CREATE A PRODUCT CODE

Output	Factory Setting	Range
	EFE300M	EFE400M
12	11.4 - 13.2V	11.4 - 13.2V
24	22.8 - 26.4V	22.8 - 26.4V
28	27 - 32V	
36	36 - 42V	
48	47 - 50V	47 - 50V
50	50 - 54V	

Required output voltage must be specified at time of ordering

Standby Voltage
5 = 5V / 2A
12 = 12V / 1A

Case/Fan Option

- HN Open frame, no fan, with 12V / 1A fan supply
- HU U chassis, no fan, with 12V / 1A fan supply
- HC Cover+chassis, no fan, with 12V / 1A fan supply
- EC Cover+chassis, end fan (temp controlled)
- NN Open frame, no fan, no fan supply
- NU U chassis, no fan, no fan supply
- NC Cover+chassis, no fan, no fan supply

-Y = ORing FET included

blank = right angled
-V = Vertical

E = Enable
T = Inhibit

M Molex kk (see page 47 for details)

L = 300µA

Confirm availability of created product code with the factory



ISOLATION			
Input to Output	Reinforced	4kVac, 5.7kVdc type tested to 4kVac (equivalent to 5.7kVdc), production tested to 4.3kVdc.	
Input to Earth	Basic	1.5kVac, 2.3 kVdc	Output to Earth 1.5kVac

OUTPUT SPECIFICATION			
	EFE300M	EFE400M	
Output Power	300W	400W	Continuous (including fan supply) or RMS (including Peak power) EFE400M derates below 100V input. See handbook for details.
Peak Power	400W	530W	EFE300M - for 10 seconds. Outputs above 36V, 350W. EFE400M - for 10 seconds. No peak power for outputs 47V and above.
Total Regulation	better than 4%		Including Line (for 90-264Vac input change), Load (for 0-100% load change) and temperature (0-50°C)
Ripple & Noise	1.5%		pk-pk, using EIAJ test method & 20MHz bandwidth
Voltage Setting Accuracy	±1%		at 50% load
Turn on Time	1.5s max		at 90 Vac & 100% rated output power
Efficiency	90%		typical. 87% typical if Standby Supply is fully loaded
Hold up	16ms		typical at 90 Vac, 75% load
Min Load	None		
Transient Response	<5%		of set voltage for 50% load change (in 50µs within the range 25 - 100% load)
Recovery	<1ms		for recovery to 2% of set voltage
Short circuit protection	Yes		Auto recovery after removal of short circuit
Over Temperature protection	Yes		Primary - auto recovers, secondary - cycle power to restart
Over Voltage Protection	Yes		Latching, need to cycle ac to restart unit.
Fan supply	12V / 1A		Depending on 'Case/Fan Option' selected. See p1 for details

GLOBAL SIGNALS	
Remote on/off	Enable - TTL logic level low (relative to Standby 0V) enables channel 1 and fan supply Inhibit - TTL logic level low (relative to Standby 0V) inhibits channel 1 and fan supply
Standby Supply	5V / 2A or 12V / 1A, isolated supply, not affected by remote on/off.
Power Good	Logic high indicates ac supply is good and Ch1 is within regulation
ORing FET	Allows redundant connection of power supplies with no additional diodes required.

ENVIRONMENT	
Temperature	0°C to 50°C operational, -40°C to 70°C storage (max 12 months). Full load, with 2m/s air blown from input to output (approximately 10CFM)
Derating	50°C to 70°C derate each output by 2.5% per °C
Low Temp Startup	-20°C
Humidity	5 - 95% RH non condensing
Shock	±3 x 30g shocks in each plane, total 18 shocks 30g shock = 11ms (+/-0.5msec), half sine Conforms to EN60068-2-27, EN60068-2-47, IEC68-2-27, IEC68-2-47, JIS C0041-1987. Conforms to MIL-STD-810E/F, Method 516.5, Pro I, IV, VI
Vibration	Single axis 10 - 500 Hz at 2g (sweep and endurance at resonance) in all 3 planes Conforms to EN60068-2-6, IEC68-2-6 Conforms to MIL-STD-810E, Method 514.4, Pro I, Cat 1,9
Altitude	Medical approval = -200 to 3000 metres operational (-200 to 5000m storage/transportation) Non medical approval = -200 to 5000 _a metres operational (-200 to 5000m storage/transportation) a - non open frame EFE400M units = -200 to 4000 metres
Pollution	Degree 2, Material group IIIb

IMMUNITY EN61000-6-2:2005				Criteria
Electrostatic Discharge	EN61000-4-2	Level 4	Air discharge 15kV Contact discharge 8kV Not applicable to open frame units	A
Electromagnetic Field	EN61000-4-3	Level 3	12V/m	A
Fast / Burst Transient	EN61000-4-4	Level 4	ac input tested to 4.4kV dc output tested to 2.2kV	A
Surge Immunity	EN61000-4-5	Level 3	Common mode - 2.2kV Differential - 1.1kV	A
Conducted RF Immunity	EN61000-4-6	Level 3	12V	A
Power Frequency Magnetic Field	EN61000-4-8	Level 4	30A/m	A
Voltage Dips, Variations, Interruptions	EN61000-4-11	Class 3	Criteria B for 5 sec interruption Criteria B for 1 cycle interruption	A
Ring Wave	EN61000-4-12	Level 3	Common mode - 2.2kV Differential - 1.1kV	A
Voltage Fluctuations	EN61000-4-14	Class 3		A



EMISSIONS EN61000-6-3:2007, EN60601-1-2:2001

Radiated Electric Field	EN55011, EN55022	(as per CISPR.11/22) Class B, FCC47 part 15 subpart B see application note for details
Conducted Emissions	EN55011, EN55022	(as per CISPR.11/22) Class B, FCC47 part 15 subpart B
Conducted Harmonics	EN61000-3-2	Class A Class C - (at 100W and above)
Flicker	EN61000-3-3	Compliant - d _{max} only

SAFETY APPROVALS

	Edition / Date	Amendments		Edition / Date	Amendments
EN 60950-1	Edition 2 - 2006		IEC 60950-1*	Edition 2 - 2005	
UL 60950-1	Edition 2 - 2007		CSA 22.2 No 60950-1	Edition 2 - 2007	
EN 61010-1	Edition 2 - 2001		IEC 61010-1*	Edition 2 - 2001	
EN60601-1	Edition 2 - 1990	A1, A2, A13	IEC60601-1*	Edition 2 - 1988	A1, A2
CE Mark	LV Directive 2006/95/EC (EN60950-1)		UL/CSA 60601-1	Edition 2 - 2003	With Revisions 2006
* CB certificate and Report available on request			Check with factory for status of approvals		

OUTLINE & CONNECTION DRAWINGS

EFE300M (not -V version)

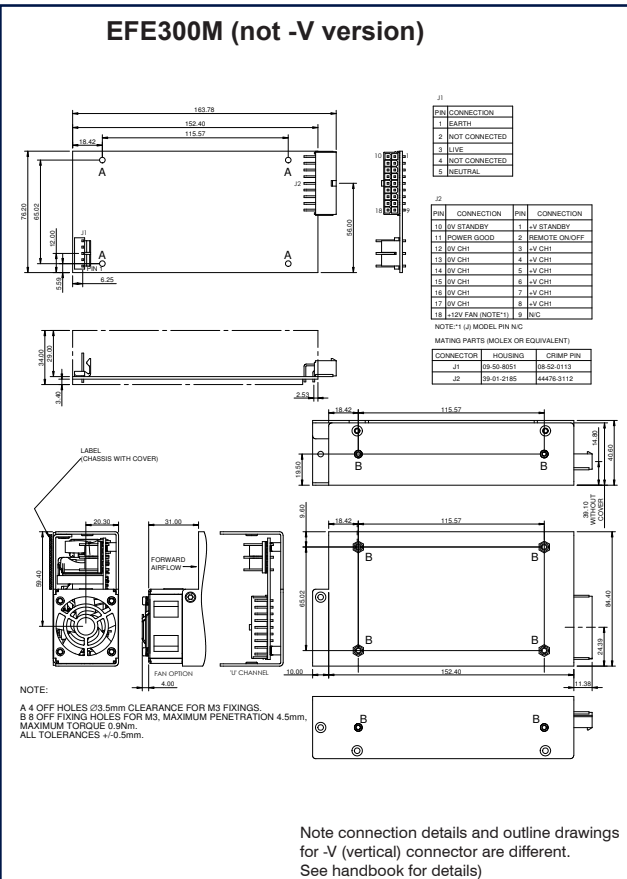

EFE400M (not -V version)

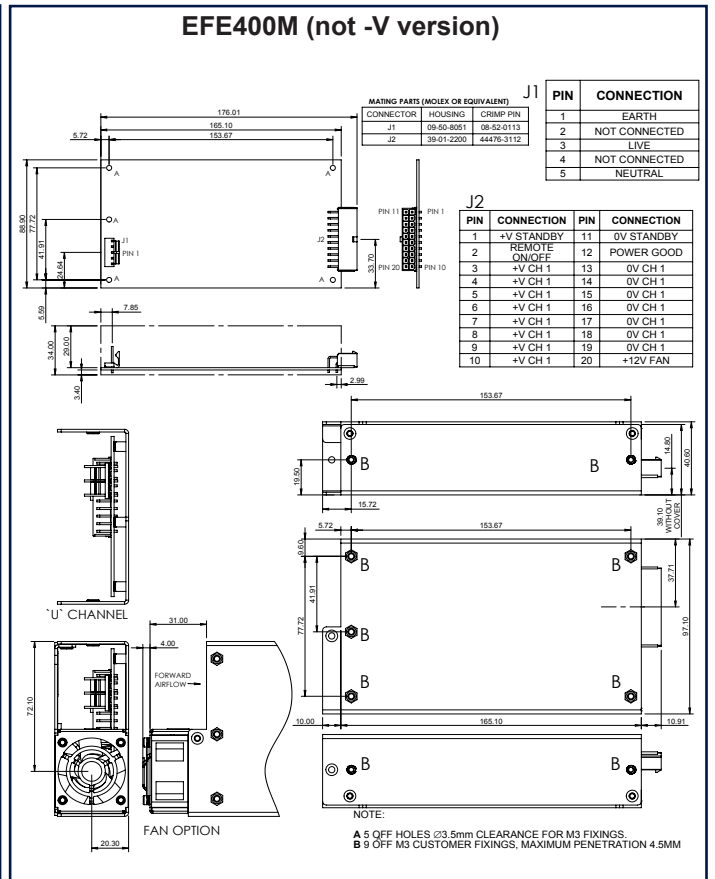

Notes 1. All customer fixings M3

2. Maximum Penetration 4.5mm

3. Maximum torque 0.9Nm

4. All tolerances +/-0.5mm



Enclosed Chassis Mount AC-DC Power Supplies

A broad range with output power from 15W to 1560W encompassing basic cost effective solutions, high grade industrial products with lifetime warranty, high efficiency models with low standby input power, fanless baseplate cooled solutions and products with low operating temperature and military standard vibration and shock specifications. Some models have medical approvals. Suitable for many types of equipment including general industrial machinery, factory automation, broadcast, kiosks, vending, displays and medical equipment.

		<i>Page No.</i>
	LS25-150 Series 150W Single Output	49
	LS200 Series 200W Single Output	54
	GWS250/500 Series 250 & 500W Single Output	57
	HWS15-150 Series 15 - 150W Single Output	60
	HWS300-1500 Series 300 - 1500W Single Output	63
	HWS HD Series 33 - 1560W Single Output	66
	HWS ME Series 30 - 1500W Single Output	69
	HWS300-600P Series 300-600W Single Output	72
	MTW Series 16 - 62W Triple Output	75
	RTW Series 41 - 312W Single Output	78
	SWS300A & 600 Series 300 & 600W Single Output	81
	SWS600L & 1000L Series 600 - 1056W Single Output	84
	RFE1000 Series 992 -1008W Single Output	87
	CPFE500F Series 432W - 500W Single Output	89
	CPFE1000F Series 720 - 1000W Single Output	92
	LZSA Series 504 - 1512W Single Output	95



LS25-150 Series

Single Output General Purpose Power Supplies

- High MTBF up to 900 000 hours
- Superior operating temperature performance up to 70°C
- Very High efficiency up to 87%
- Very Low Cost
- Compact
- Withstands 300VAC surges (5s)
- Three Year Warranty

Key Market Segments & Applications

- Test & Measurement
- Automated Service
- Factory Automation
- General Purpose
- LED Lighting & Display

LS25-150 Features and Benefits

Features

- High MTBF
- High efficiency
- -25 to +70°C operating temperature
- Low derating above 50 °C (up to 70% load available at 70° C)
- Curve B EMC

Benefits

- Superior Reliability
- Easier system cooling
- Suitable for indoor & outdoor enclosures
- Improved system power optimisation
- Assists system compliance

Specifications

ITEMS		LS25	LS35	LS50	LS75	LS100	LS150	
AC Input Voltage (300VAC for 5s)	VAC	88 - 264VAC (See note (2) for LS100)					88-132/176-264VAC(1)	
Input Frequency	Hz	47 - 63Hz						
DC Input Voltage	VDC	125 - 373VDC				248 - 273VDC		
Inrush Current (230VAC, cold start)	A	30	40	40	40	60	40	
Power Factor	-	Meets EN61000-3-2, -3						
Input Current (115/230VAC)	A	0.7 / 0.4	0.8 / 0.55	1.3 / 0.8	1.6 / 1.0	2.2 / 1.2	3.5 / 2	
Temperature Coefficient	-	<0.02%/°C (0 - 50°C)						
Overcurrent Protection	-	> 110%						
Overvoltage Protection	V	3.3V: 3.8-4.45V, 5V: 5.75-6.75V, 12V: 13.8-16.2V, 15V: 17.25-20.25V, 24V: 27.6-32.4V, 36V: 41.4-48.6V, 48V: 55.2-64.8V						
Hold Up Time (115 / 230V input)	ms	14 / 80	12 / 80	14 / 60	14 / 60	25 / 150	20 / 28	
Leakage Current (230VAC 60Hz)	mA	TBA		<1mA		<1mA		
Remote Sense	-	No						
LED Indicator	-	Green LED = On						
Operating Temperature	-	-25 to +70°C. Derate linearly to 50% load from +50 to +70°C (2)						
Storage Temperature	°C	-40 to +85°C						
Operating Humidity	-	20 - 90% RH (non condensing)						
Storage Humidity	-	10 - 95% RH (non condensing)						
Cooling	-	Convection						
Withstand Voltage	-	Input to Ground 1.5kVAC, Input to Output 3kVAC, Output to Ground 500VAC for 1 min.						
Isolation Resistance	-	>100MΩ at 25°C & 70%RH, Output to Ground 500VDC						
Vibration (non operating)	-	10 - 55Hz: 19.6m/s ² constant sweep 1 min X, Y, Z for 1 hour						
Shock	-	< 196.1 m/s ² (20G)						
Immunity	-	IEC61000-4-2, -3, -4, -5, -6, -8, -11						
Safety Agency Approvals	-	UL60950-1, EN60950-1, IEC60950-1, CE Mark						
Conducted & Radiated EMI	-	EN55011/EN55022-B, FCC-B						
MTBF (MIL-HDBK-217F)	hrs	906,997	706,464	712,890	648,786	545,375	505,393	
Weight (Typ)	g	170	270	350	410	600	700	
Size (LxWxH)	mm	79 x 51 x 28	99 x 82 x 36	99 x 97 x 36	130 x 97 x 38	160 x 97 x 38	198 x 99 x 38	
Warranty	yrs	3						



Model Selector							
Model	Voltage	Adjust Range (V)	Max Current (A)	Load Reg (mV)	Line Reg (mV)	Ripple Noise (mV)	Efficiency (typ) %
LS25-3.3	3.3V	3.0 - 3.3	6	66	16.5	80	72
LS25-5	5V	4.75 - 5.5	5	50	25	80	77
LS25-12	12V	10.8 - 13.2	2.1	60	60	120	79
LS25-15	15V	13.5 - 16.5	1.7	75	75	120	82
LS25-24	24V	22 - 27.2	1.1	120	120	120	84
LS25-36	36V	32 - 40	0.75	150	150	150	85
LS25-48	48V	42 - 54	0.57	180	180	200	85
LS35-3.3	3.3V	3.0 - 3.3	7	66	16.5	80	73
LS35-5	5V	4.75 - 5.5	7	50	25	80	77
LS35-12	12V	10.8 - 13.2	3	60	60	120	81
LS35-15	15V	13.5 - 16.5	2.4	75	75	120	83
LS35-24	24V	22 - 27.2	1.5	120	120	120	84
LS35-36	36V	32 - 40	1	150	150	150	84
LS35-48	48V	42 - 54	0.8	180	180	200	84
LS50-3.3	3.3V	3.0 - 3.6	10	40	20	80	75
LS50-5	5V	4.75 - 5.5	10	40	20	80	80
LS50-12	12V	10.8 - 13.2	4.2	96	48	120	84
LS50-15	15V	13.5 - 16.5	3.4	120	60	120	85
LS50-24	24V	22 - 27.2	2.2	192	96	120	86
LS50-36	36V	32 - 40	1.4	288	144	150	86
LS50-48	48V	42 - 54	1.1	384	192	200	86
LS75-3.3	3.3V	3.0 - 3.6	15	40	20	80	75
LS75-5	5V	4.75 - 5.5	12	40	20	80	79
LS75-12	12V	10.8 - 13.2	6	96	48	120	84
LS75-15	15V	13.5 - 16.5	5	120	60	120	85
LS75-24	24V	22 - 27.2	3.2	192	96	120	86
LS75-36	36V	32 - 40	2.1	288	144	150	86
LS75-48	48V	42 - 54	1.6	384	192	200	87
LS100-3.3	3.3V	3.0 - 3.3	20	66	16.5	80	74
LS100-5	5V	4.75 - 5.5	16	50	25	80	77
LS100-12	12V	10.8 - 13.2	8.5	60	60	120	81
LS100-15	15V	13.5 - 16.5	7	75	75	120	82
LS100-24	24V	22 - 27.2	4.5	120	120	120	84
LS100-36	36V	32 - 40	3	150	150	150	84
LS100-48	48V	42 - 54	2.3	180	180	200	84
LS150-3.3	3.3V	3.0 - 3.3	30	66	16.5	80	74
LS150-5	5V	4.75 - 5.5	26	50	25	80	78
LS150-12	12V	10.8 - 13.2	12.5	60	60	120	83
LS150-15	15V	13.5 - 16.5	10	75	75	120	84
LS150-24	24V	22 - 27.2	6.5	120	120	120	86
LS150-36	36V	32 - 40	4.3	150	150	150	86
LS150-48	48V	42 - 54	3.3	180	180	200	87

Notes: See page 1

- (1) Switch selectable for 115 or 230VAC
- (2) LS50, LS75-3.3 & -5: Derate linearly to 70% load from +50 to +70°C.
 LS75-12,-15,-24,-36,-48 Derate linearly to 60% load from +50 to +70°C.
 LS100-3.3 & 5 Derate linearly to 60% load from +45 to +70°C. Derate linearly to 80% load from 115V to 88VAC input.
 LS100-12,-15,-24,-36,-48 Derate linearly to 60% load from +50 to +70°C. Derate linearly to 80% load from 115V to 88VAC input.
 LS150-3.3 & 5 Derate linearly to 50% load from +40 to +70°C.
 LS150-12,-15,-24,-36,-48 Derate linearly to 70% load from +50 to +70°C.



Outline Drawing LS25

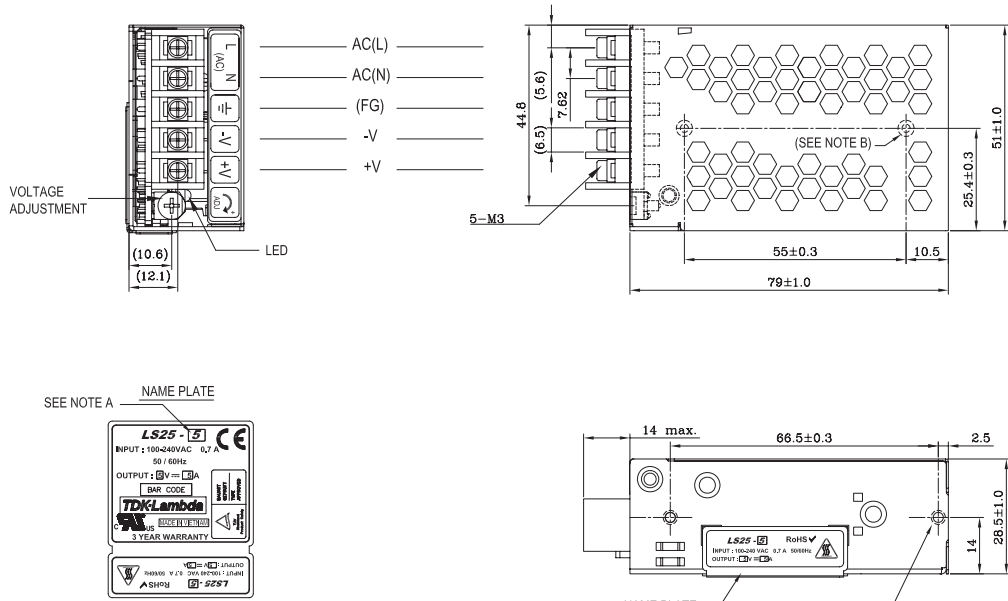

NOTES

- A. MODEL NAME, INPUT VOLTAGE RANGE, NOMINAL OUTPUT VOLTAGE, MAXIMUM OUTPUT CURRENT & COUNTRY OF MANUFACTURE ARE SHOWN IN ACCORDANCE WITH THE SPECIFICATION.
- B. M3 TAPPED, EMBOSSED & COUNTERSUNK HOLES (4) FOR CUSTOMER CHASSIS MOUNTING. SCREWS MUST NOT PROTRUDE INTO POWER SUPPLY BY MORE THAN 4mm.
- C. UNLESS OTHERWISE SPECIFIED, DIMENSION TOLERANCE = ±0.3mm.

Outline Drawing LS35

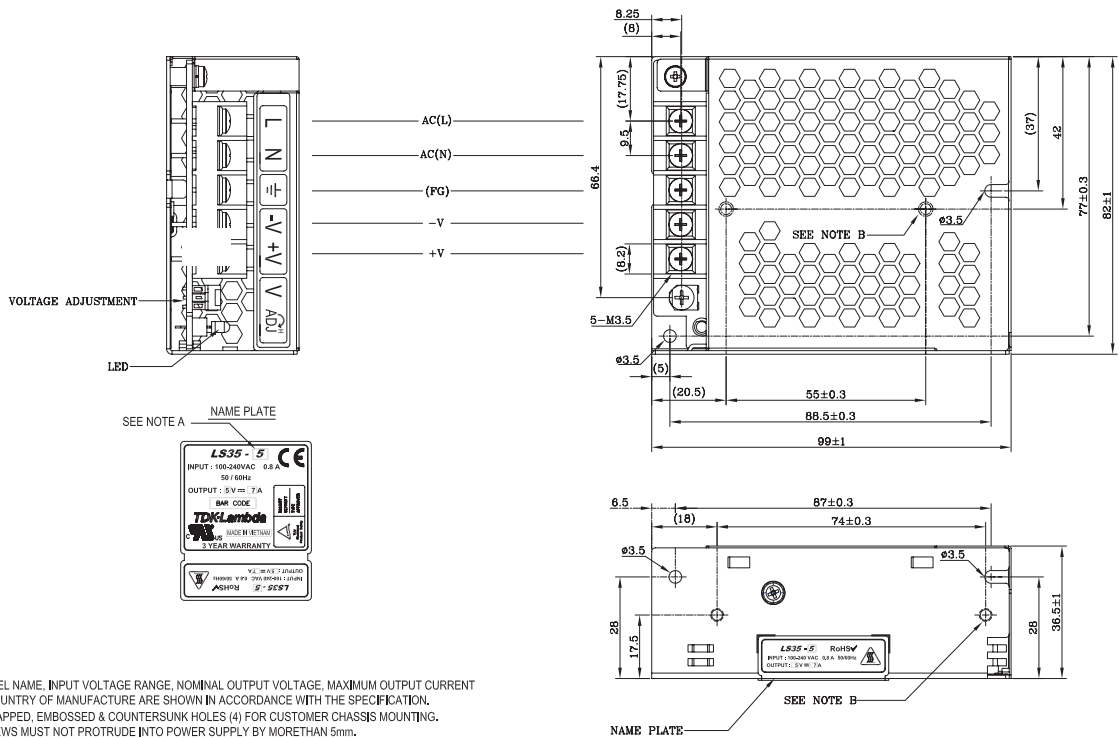

NOTES

- A. MODEL NAME, INPUT VOLTAGE RANGE, NOMINAL OUTPUT VOLTAGE, MAXIMUM OUTPUT CURRENT & COUNTRY OF MANUFACTURE ARE SHOWN IN ACCORDANCE WITH THE SPECIFICATION.
- B. M3 TAPPED, EMBOSSED & COUNTERSUNK HOLES (4) FOR CUSTOMER CHASSIS MOUNTING. SCREWS MUST NOT PROTRUDE INTO POWER SUPPLY BY MORE THAN 5mm.
- C. UNLESS OTHERWISE SPECIFIED, DIMENSION TOLERANCE = ±0.3mm.



Outline Drawing LS50

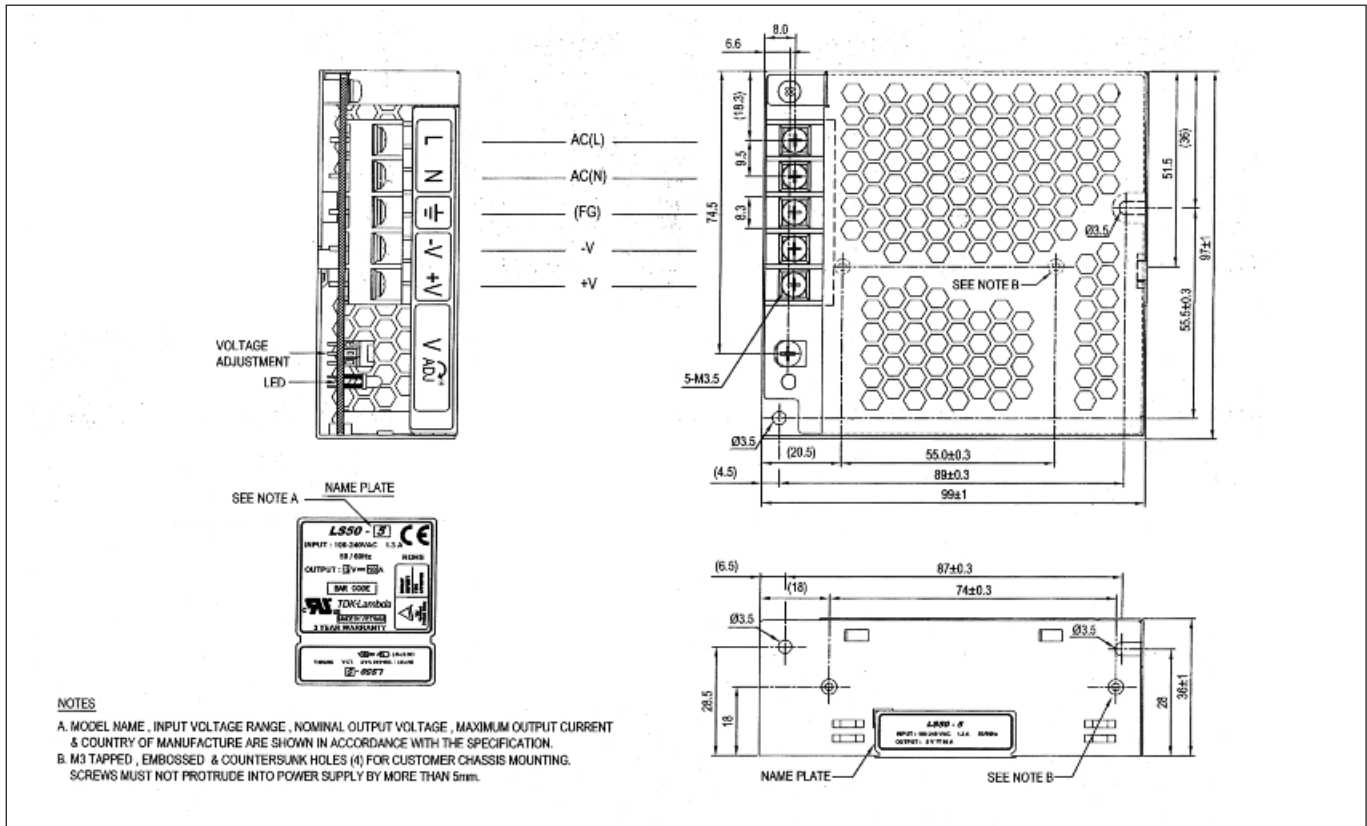

Outline Drawing LS75

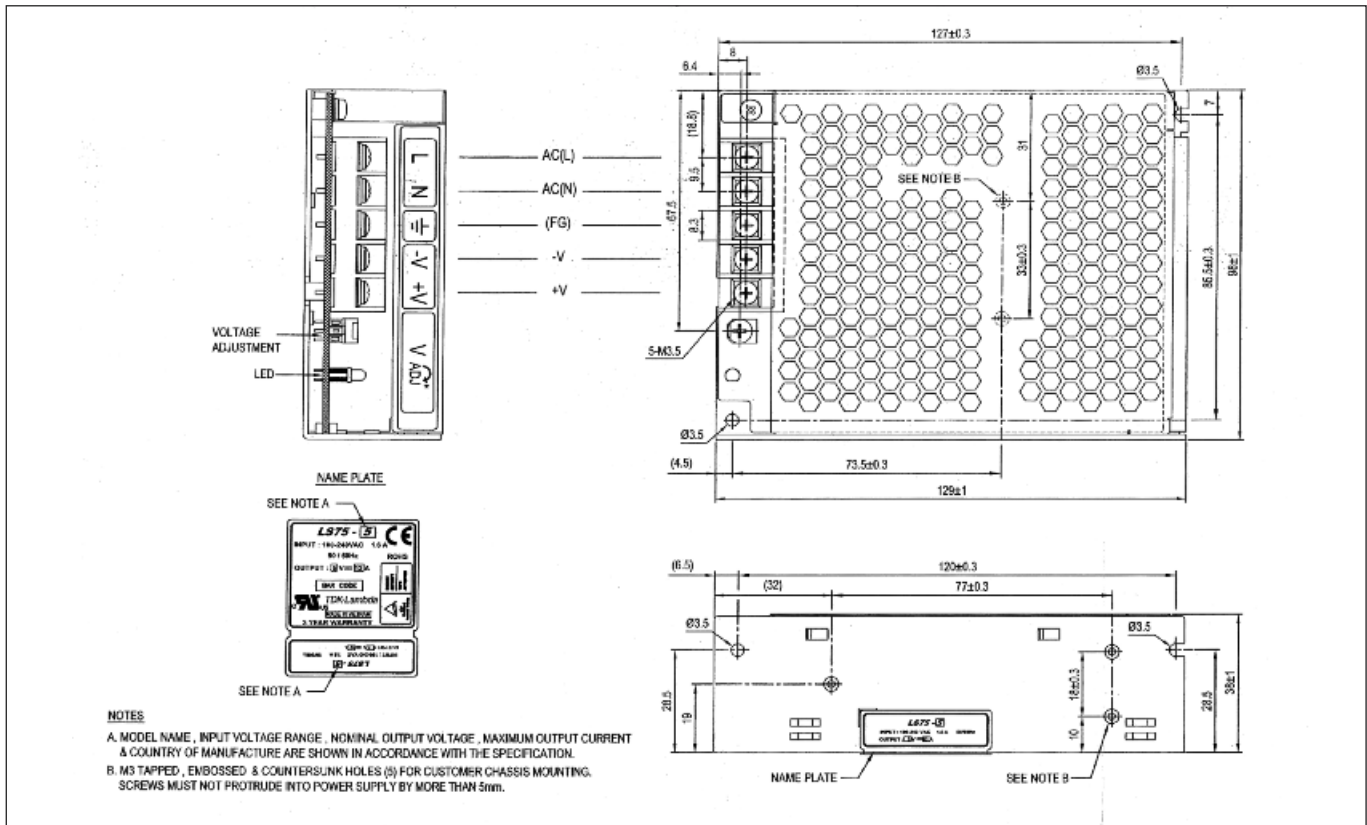



Outline Drawing LS100

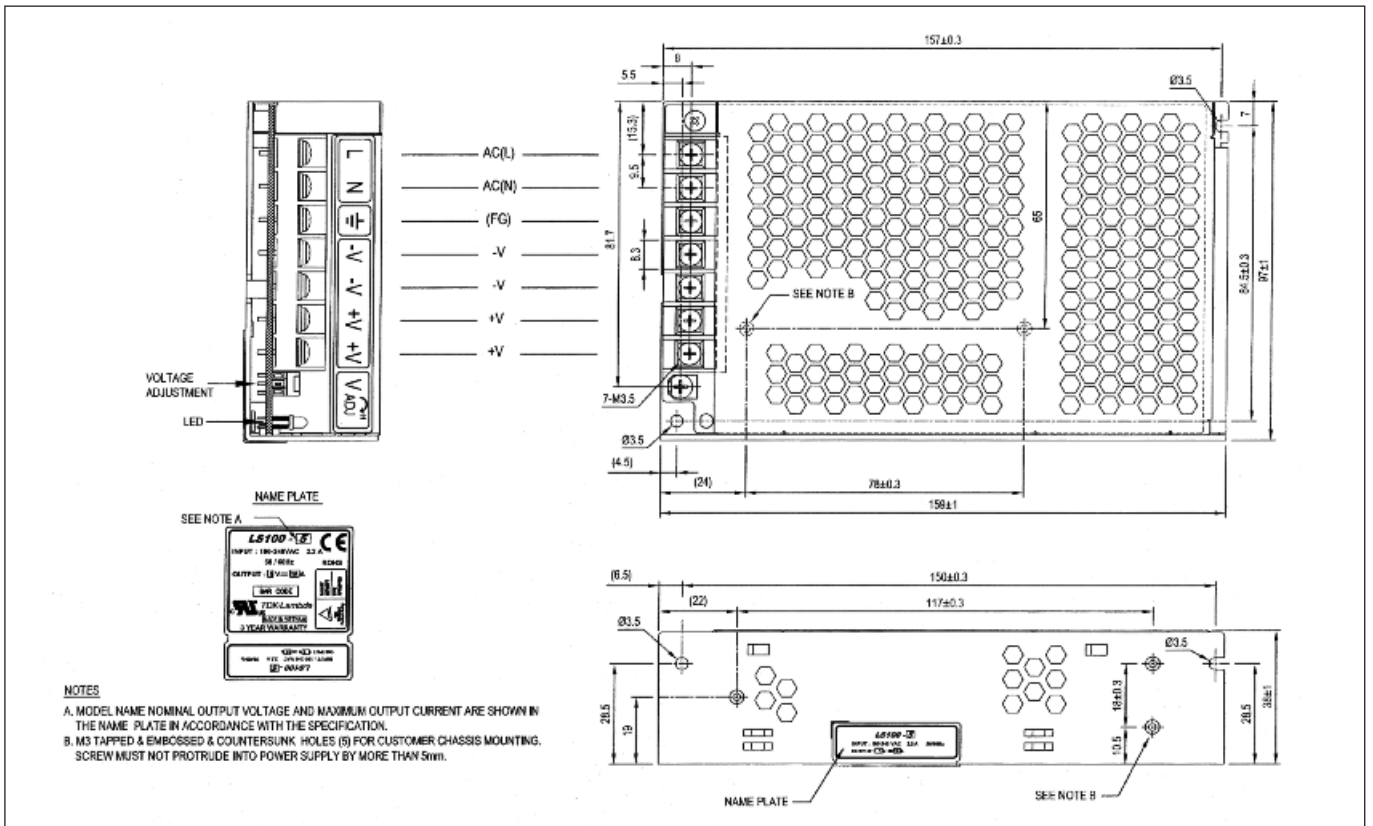

Outline Drawing LS150

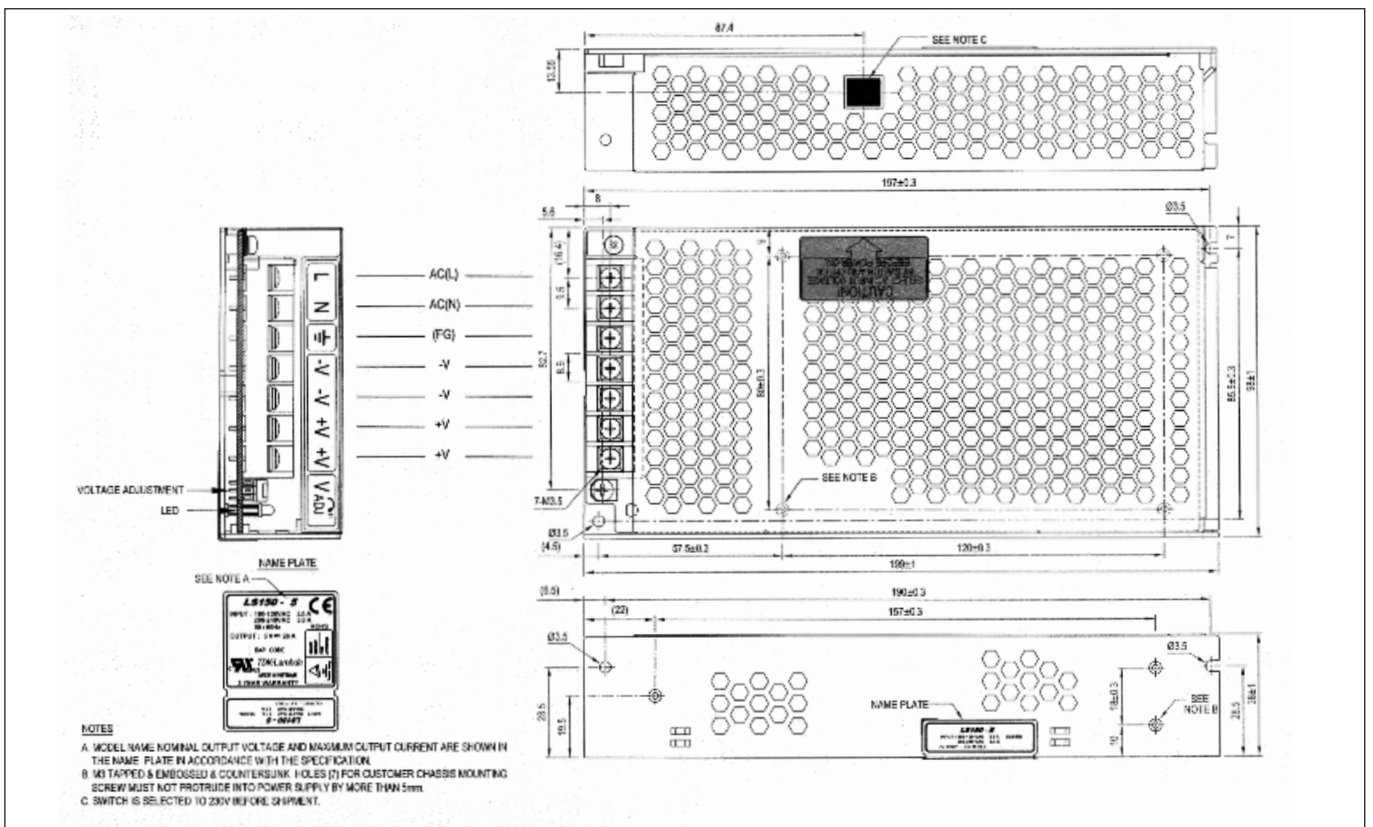



- Very low cost
- Small size
- Power factor corrected
- Wide range AC Input
- Convection or fan cooled
- Three year warranty
- 41mm high (for 1U racking)
- 250W peak rating on 24 & 36V models

LS200 Series

Single Output 150 - 200W
General Purpose Power Supplies

Key Market Segments & Applications

Test and Measurement	Light Industrial
Automated Service	Kiosks
LED Lighting & Displays	

LS200 Features and Benefits

Features

- High MTBF
- High efficiency
- -25 to +70°C operating temperature
- Low derating above 50°C (up to 60% load available at 70°C)
- Curve B EMC

Benefits

- Superior reliability
- Easier system cooling
- Suitable for indoor & outdoor enclosures
- Improved system power optimisation
- Assists system compliance

Specifications

MODEL		LS200 (enclosed style with internal fan)	LS200/L (U channel style - no internal fan)
ITEMS			
AC Input Voltage (300VAC for 5s)	VAC	85 - 264VAC	
Input Frequency	Hz	47 - 63Hz	
DC Input Voltage	VDC	120 - 373VDC	
Inrush Current (230VAC, cold start)	A	60	
Power Factor	-	Meets EN61000-3-2, -3 (Typical PF 0.98/0.95) (1)	
Input Current (115/230VAC)	A	3.5 / 1.7 (typical)	
Temperature Coefficient	-	<0.02%/°C (0 - 50°C)	
Overcurrent Protection (2)	-	> 105% of nominal or peak. Constant current style	
Overvoltage Protection (2)	V	3.3V: 3.8 - 4.45V, 5V: 5.75 - 6.75V, 7.5V: 8.6 - 8.1V, 12V: 15.1 - 17.75V 15V: 17.25 - 20.25V, 24V: 30.25 - 35.5V, 36V: 41.4 - 48.6V, 48V: 60 - 69.6V	
Hold Up Time (115/230V input)	ms	20ms	
Leakage Current (230VAC 60Hz)	mA	<1mA	
Remote Sense	-	Yes	
Remote On/Off	-	On: 0 - 0.8V; Off: 3 - 12V	
LED Indicator	-	Green LED = On	
Operating Temperature	-	-25 to +70°C see derating curves	
Storage Temperature	°C	-40 to +85°C	
Operating Humidity	-	20 - 90% RH (non condensing)	
Storage Humidity	-	10 - 95% RH (non condensing)	
Cooling	-	Fan cooled (exhaust from fan end)	Convection or customer supplied airflow
Withstand Voltage	-	Input to Ground 1.5kVAC, Input to Output 3kVAC, Output to Ground 500VAC for 1 min.	
Isolation Resistance	-	>100MΩ at 25°C & 70%RH, Output to Ground 500VDC	
Vibration (non operating)	-	10 - 55Hz: 19.6m/s ² constant sweep 1 min X, Y, Z for 1 hour	
Shock	-	< 196.1 m/s ² (20G)	
Immunity	-	IEC61000-4-2, -3, -4, -5, -6, -8, -11	
Safety Agency Approvals	-	UL60950-1, CSA60950-1 (cUL), IEC60950-1 2nd Edition, CE Mark	
Conducted & Radiated EMI	-	EN55011/EN55022-B, FCC-B	
MTBF (MIL-HDBK-217F)	hrs	300,000	
Weight (Typ)	g	700	600
Size (LxWxH)	mm	199 x 98 x 41	
Warranty	yrs	3	

Notes (1) 115 / 230VAC input

(2) Recycle AC to reset



Model Selector

Model	Voltage	Adjust Range Range (V)	Max Current (A) (3)	Max Current Convection (A)	Peak Current <10s, >35% DC (A)	Load Reg (mV)	Line Reg (mV)	Ripple Noise (mV)	Efficiency (typ) % (1)
LS200-3.3	3.3V	3.0 - 3.6	40	N/A	-	40	16	80	67 / 68
LS200-5	5V	4.75 - 5.5	40	N/A	-	40	20	80	72 / 75
LS200-7	7.5V	6.8 - 8.2	26.7	N/A	-	40	20	80	74 / 77
LS200-12	12V	10.8 - 14.4	16.7	N/A	-	96	48	120	76 / 79
LS200-15	15V	13.5 - 16.5	13.4	N/A	-	120	60	120	80 / 83
LS200-24	24V	22 - 28.8	8.4	N/A	10.4	192	96	120	82 / 84
LS200-36	36V	32 - 40	5.6	N/A	6.9	288	144	150	82 / 85
LS200-48	48V	42 - 57.6	4.2	N/A	-	384	192	200	82 / 85
LS200-3.3/L	3.3V	3.0 - 3.6	40	32	-	40	16	80	67 / 68
LS200-5/L	5V	4.75 - 5.5	40	32	-	40	20	80	72 / 75
LS200-7/L	7.5V	6.8 - 8.2	26.7	21.36	-	40	20	80	74 / 77
LS200-12/L	12V	10.8 - 14.4	16.7	15	-	96	48	120	76 / 79
LS200-15/L	15V	13.5 - 16.5	13.4	12	-	120	60	120	80 / 83
LS200-24/L	24V	22 - 28.8	8.4	7.5	10.4	192	96	120	82 / 84
LS200-36/L	36V	32 - 40	5.6	5	6.9	288	144	150	82 / 85
LS200-48/L	48V	42 - 57.6	4.2	3.78	-	384	192	200	82 / 85

Notes

(3) Internal fan version or customer supplied airflow for /L models

Options

Suffix	Description
/L	No cover or fan (U channel)
Blank	Cover and fan

Derating Curve LS200

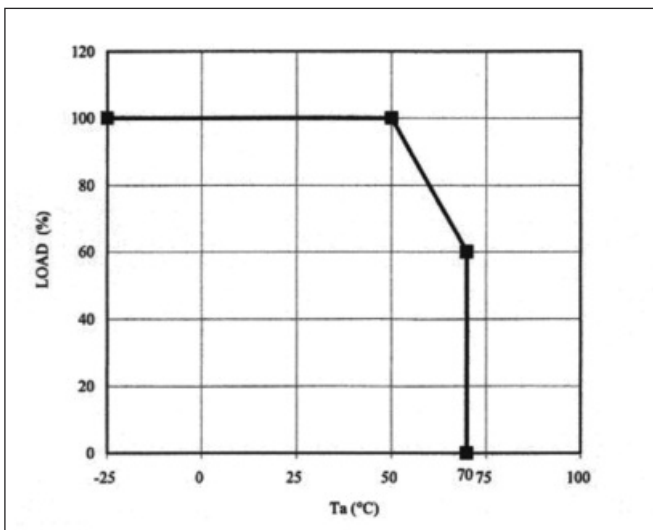



Derating Curve LS200/L

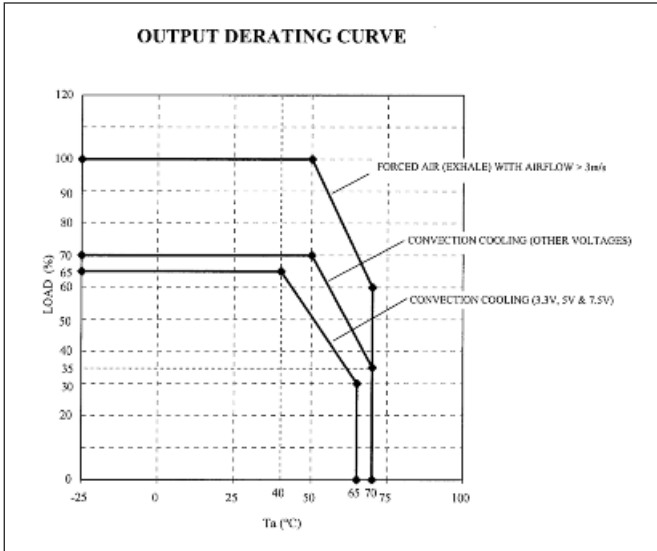

Outline Drawing LS200 Series

SIGNAL CONNECTOR INFORMATION

S8B-PHDSS (LF)(SN)

- +V_L
- +S
- V_L
- S
- NC
- NC
- CNT+
- CNT-

SIGNAL CONNECTOR USED

PART DESCRIPTION	PART NAME	MANUFACT
PIN HEADER	S10B-PHDSS(LF)(SN) (CN2)	JST

MATCHING HOUSINGS, PIN & TOOL

PART DESCRIPTION	PART NAME	MANUFACT
SOCKET HOUSING	PHDR-10VS (CN2)	JST
TERMINAL PINS	SPHD-002T-P05(AWG28-24) SPHD-001T-P05(AWG28-22)	JST
HAND CRIMPING TOOL	YRS-620 (SPHD-002T-P0.5) YC-610R (SPHD-001T-P0.5)	JST

ACCESSORIES

* SHORT PIECE _____

SHORTING +V_L — +S, -V_L — -S, CNT+ — CNT- (ATTACHED ON CN2 AT SHIPMENT)

NAME PLATE

Dimensions: 199.0±1.0, 70.0, 65.0±0.3, 88.0±1.0, 49.0±0.3, 8.0, 117.0±0.3, 25.0, 11.0 (MAX), 15.0, 20.0±0.3, 27.0±0.3, 47.0±1.0, 8.0.

Labels: AC(L), AC(N), (FG), -V_L, -V, +V, +V, LED, VOLTAGE ADJUSTMENT, CN2, NAME PLATE, SEE NOTE C, SEE NOTE B.

NOTES

A. MODEL NAME NOMINAL OUTPUT VOLTAGE AND MAXIMUM OUTPUT CURRENT ARE SHOWN IN THE NAME PLATE IN ACCORDANCE WITH THE SPECIFICATION.

B. M4 COUNTERSUNK & EMBOSSED HOLES (2) FOR CUSTOMER CHASSIS MOUNTING

C. M4 COUNTERSUNK & EMBOSSED HOLES (8) FOR CUSTOMER CHASSIS MOUNTING



- Standby Power Draw < 0.5 Watt
- Average Active Efficiency above ErP Requirements
- 41 mm height only, allowing 1 U Racking
- 250 Watt Convection cooled
- 500 Watt with Low Fan Noise (exhale)
- 5V / 300mA Aux Supply on board
- Output Remote Programming
- Five Year Warranty

GWS Series

Single Output 250 & 500W Power Supplies

Key Market Segments & Applications

Targets all EuP/ErP compliant applications
 Industrial, Traffic Controls, Automated Service, Kiosks
 Test & Measurement, Entertainment Systems
 Front End for Communications & Broadcasting, LED, Display & Signage

GWS Features and Benefits

Features

- Programmable Output Voltage
- Peak Power Capability
- High Efficiency

Benefits

- Broad Range of Applications
- Lower Cost, Smaller Size
- Easier System Cooling, Less Energy Used, Environmental Profit

Specifications

ITEMS		MODEL	GWS250	GWS500
AC Input Voltage (300VAC for 5s)	VAC		85 - 264VAC	
Input Frequency	Hz		47 - 63Hz	
DC Input Voltage	VDC		120 - 373VDC	
Inrush Current (cold start)	A		20A at 115VAC, 40A at 230VAC	
Power Factor (1)	-		Meets EN61000-3-2 (Typical PF 0.98/0.95)	
Input Current (115/230VAC)	A		3.0 / 1.4	5.5 / 2.7 (4.5 / 2.3 for 5V model)
Temperature Coefficient	°C		<0.02%/°C (0 - 50°C)	
Overcurrent Protection	-		>105% of nominal or >101% of peak. 5V-12V hiccup style, 24V-48V Constant current style	
Overvoltage Protection (2)	V		5V: 5.75 - 6.75V, (3) 7.5V: 8.6 - 10.1V, (3) 12V: 13.8 - 16.2V, 24V: 30.3 - 35.5V, 36V: 41.4 - 48.6V, 48V: 60 - 69.6V	
Overtemperature Protection (2)	-		Yes	
Hold Up Time (115 / 230V input)	ms		16ms	
Leakage Current (230VAC 60Hz)	mA		<0.75mA	
Remote Sense	-		No	Yes
Remote On/Off	-		Active Low	
Standby Input Power Draw	W		<0.5W	
5V Standby (always on)	-		5V 0.3A	
DC Good	-		DC Good, open collector signal, High on Fail	
LED Indicator	-		Green LED = On	
Output Remote Programming	-		See installation manual for details	
Operating Temperature	°C		-25°C to +70°C. Derate linearly to TBD % load from +50°C to +70°C	
Storage Temperature	°C		-30°C to +85°C	
Operating Humidity	-		30 - 90% RH (non condensing)	
Storage Humidity	-		10 - 95% RH (non condensing)	
Cooling	-		Convection	Internal fan
Withstand Voltage	-		Input to Ground 1.5kVAC, Input to Output 3kVAC, Output to Ground 500VAC for 1 min.	
Isolation Resistance	-		>100MΩ at 25°C & 70%RH, Output to Ground 500VDC	
Vibration (non operating)	-		10 - 55Hz: 19.6m/s ² constant sweep 1 min X, Y, Z for 1 hour	
Shock	-		< 196.1 m/s ² (20G)	
Immunity	-		IEC61000-4-2 (lv 2, 3), -3 (lv3), -4 (lv 3), -5 (lv 4), -6 (lv 3), -8 (lv 4), -11	
Safety Agency Approvals	-		UL60950-1, CSA C22.2 No 60950-1-07 (cUL), EN60950-1 2nd Edition, IEC60950-1, CE Mark	
Conducted & Radiated EMI	-		EN55022-B, FCC-B	
Weight (Typ)	g		850	1020
Size (L x W x H)	mm		199 x 105 x 41	219 x 105 x 41
Warranty	yrs		5	

Notes: (1) 115 / 230VAC input (2) Recycle AC, or use remote on/off to reset (3) 500W models



Model Selector

Model	Voltage (V)	Adjust Range (V)	Max Current (A)	Peak Curr. <10s, <35% DC (A)	Load Reg. (mV)	Line Reg. (mV)	Ripple Noise (mV)	Efficiency (typ) % (230VAC)
GWS500-5	5V	4.75 - 5.5	80	-	50	25	150	85
GWS500-7.5	7.5V	6.75 - 8.25	67.2	-	70	35	150	88
GWS250-12	12V	10.8 - 13.2	21	-	96	48	150	92
GWS500-12	12V	10.8 - 13.2	42	-	96	48	150	90
GWS250-24	24V	22 - 28.8	10.5	12.5	192	96	240	92
GWS500-24	24V	22 - 28.8	21	25.0	192	96	240	91
GWS250-36	36V	32 - 40	7	8.4	288	144	360	93
GWS500-36	36V	32 - 40	14	16.7	288	144	360	91
GWS250-48	48V	42 - 57.6	5.3	-	384	192	480	93
GWS500-48	48V	42 - 57.6	10.5	-	384	192	480	91

Outline Drawing GWS250

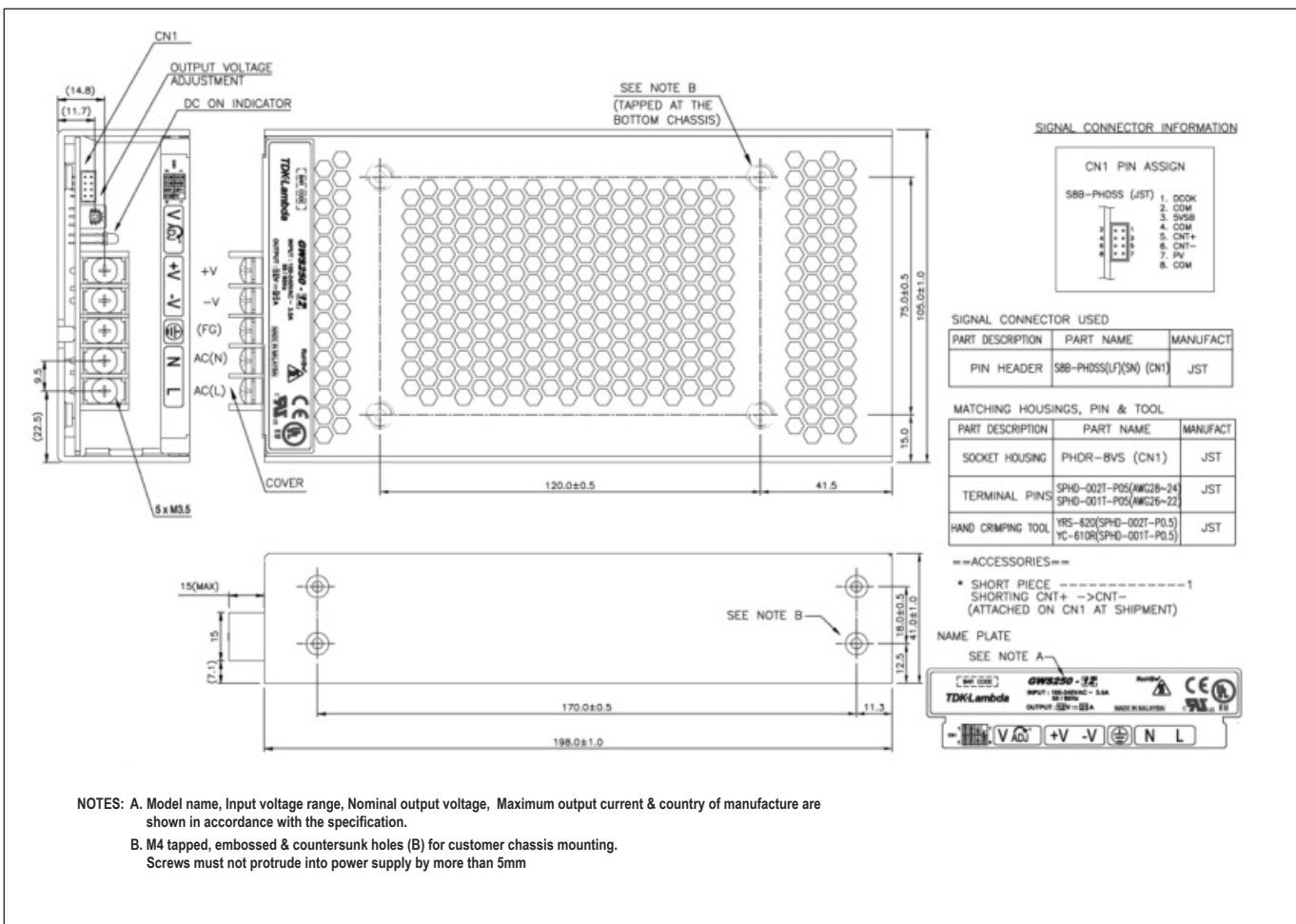



Outline Drawing GWS500

SIGNAL CONNECTOR INFORMATION

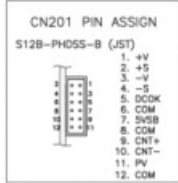

SIGNAL CONNECTOR USED

PART DESCRIPTION	PART NAME	MANUFACT
PIN HEADER	S12B-PHDS5-B(LF)(SN) (CN201)	JST

MATCHING HOUSINGS, PIN & TOOL

PART DESCRIPTION	PART NAME	MANUFACT
SOCKET HOUSING	PHDR-12V5 (CN201)	JST
TERMINAL PINS	SPHD-002T-P05(ANG28-24) SPHD-001T-P05(ANG26-22)	JST
HAND CRIMPING TOOL	HRS-620(SPHD-002T-P0.5) YC-610R(SPHD-001T-P0.5)	JST

==ACCESSORIES==

* SHORT PIECE -----1
 SHORTING +V ---+S, -V --- -S, CNT+ --- CNT-
 (ATTACHED ON CN201 AT SHIPMENT)

NAME PLATE :

SEE NOTE A

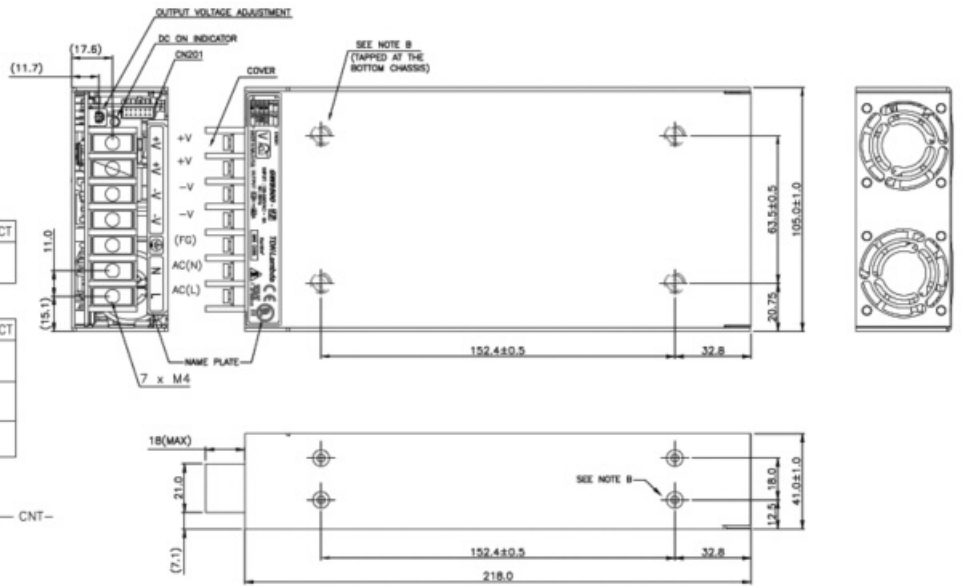
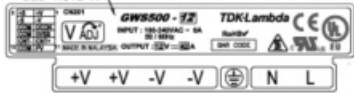

NOTES: A. Model name, Input voltage range, Nominal output voltage, Maximum output current & country of manufacture are shown in accordance with the specification.

B. M4 tapped, embossed & countersunk holes (B) for customer chassis mounting.
 Screws must not protrude into power supply by more than 5mm



- Lifetime Warranty
- UL508 approved
- SEMI F47 Compliant (high line AC)
- Universal Input (85 - 265VAC)
- High Efficiency
- RoHS Compliant Design

Key Market Segments & Applications

- | | |
|--------------------|---|
| Factory Automation | Process Control, NC-Machining, Automotive, Packaging Equipment, Materials Handling, Chemical Processing, Robots |
| Test & Measurement | Burn-in & Test, Automated |
| Automated Service | Test, Instrumentation, Measurement, Detection |

HWS Series

15 -150W Single Output Industrial Power Supplies

HWS Features and Benefits

Features

- Lifetime Warranty
- High Efficiency
- Wide Range AC Input

Benefits

- Lower Cost of Ownership
- Easier System Cooling
- Supports Global Use

Specifications

ITEMS	MODELS	HWS15					HWS30					HWS50					HWS100					HWS150				
Input Voltage range	-	85 - 265VAC (47 - 63Hz) or 120 - 370VDC																								
Input Current (Typ) (1)	A	0.4/0.2 (3.3V: 0.3 / 0.5)			0.8/0.4 (3.3V: 0.6 / 0.3)			0.7/0.35 (3.3V: 0.5 / 0.25)			1.3/0.65 (3.3V: 0.9 / 0.45)			1.9/0.95 (3.3V: 1.3 / 0.65)												
Inrush Current 100/200VAC	A	14 / 28																								
Power Factor	-	Meets EN61000-3-2																								
Temperature Coefficient	-	<0.02%/°C																								
Overcurrent Protection	-	Yes																								
Overvoltage Protection	V	Yes (See page 2)																								
Hold Up Time (Typ)	ms	20																								
Leakage Current (max)	mA	<0.5 (Typ 0.2 at 100VAC, 0.4 at 230VAC)																								
Remote Sense	-	No										Yes														
Indicator	-	Green LED = ON																								
Operating Temp. (no cover)	°C	-10°C to 70°C, derate linearly to 20% load from 50°C to 70°C																								
Storage Temperature	°C	-30°C to 85°C																								
Humidity (non condensing)	% RH	Operating: 30 - 90, Non operating 10 - 95																								
Cooling	-	Convection																								
Withstand Voltage	-	Input to Ground 2kVAC, Input to Output 3kVAC, Output to Ground 500VAC for 1 min.																								
Isolation Resistance	-	>100MΩ at 25°C & 70%RH, Output to Ground 500VDC																								
Vibration (non operating)	-	10 - 55Hz (1 minute sweep), 19.6m/s ² constant X, Y, Z 1 hour																								
Shock	-	< 196.1m/s ²																								
Safety Agency Approvals	-	-UL60950-1, CSA60950-1, EN60950-1, EN50178, Built to meet UL508 CE Mark																								
Line Dip	-	Complies with SEMI F47 (200VAC line only)																								
Conducted & Radiated	-	EN55011 / EN55022-B, FCC-B, VCCI-B																								
Immunity	-	IEC61000-4-2(Level 2,3), -3(Level 3), -4(Level 3), -5(Level 3,4), -6(Level 3), -8(Level 4), -11																								
Weight (Typ)	g	180			220			280			450			500												
Size (WxHxD)	mm	26.5x82x80			26.5x82x95			26.5x82x120			28x82x160			37x82x160												
Warranty	-	Lifetime Warranty (See TDK-Lambda's terms & conditions)																								

Notes: (1) 100/200VAC

See website for HWS/ME medical EN/UL60601-1 approved models and HWS/HD heavy duty / harsh environment models with -40 °C startup. HWS80 is also available but no specification in this catalogue.



Model Selector

Model	Voltage	Adjust Range	Maximum Current (A)	Load Reg (mV)	Line Reg (mV)	Ripple Noise (mV)	Over Voltage (V)	Efficiency typ % 100/200 VAC
HWS15-3/A	3.3V	2.97 - 3.96	3	40	20	120	4.13-4.95	68/71
HWS30-3/A	3.3V	2.97 - 3.96	6	40	20	120	4.13-4.95	70/73
HWS50-3/A	3.3V	2.97 - 3.96	10	40	20	120	4.13-4.95	76/78
HWS100-3/A	3.3V	2.97 - 3.96	20	40	20	120	4.13-4.95	78/81
HWS150-3/A	3.3V	2.97 - 3.96	30	40	20	120	4.13-4.95	78/81
HWS15-5/A	5V	4.0 - 6.0	3	40	20	120	6.25-7.25	77/79
HWS30-5/A	5V	4.0 - 6.0	6	40	20	120	6.25-7.25	77/80
HWS50-5/A	5V	4.0 - 6.0	10	40	20	120	6.25-7.25	82/84
HWS100-5/A	5V	4.0 - 6.0	20	40	20	120	6.25-7.25	83/86
HWS150-5/A	5V	4.0 - 6.0	30	40	20	120	6.25-7.25	83/86
HWS15-12/A	12V	9.6 - 14.4	1.3	96	48	150	15-17.4	80/81
HWS30-12/A	12V	9.6 - 14.4	2.5	96	48	150	15-17.4	81/83
HWS50-12/A	12V	9.6 - 14.4	4.3	96	48	150	15-17.4	81/83
HWS100-12/A	12V	9.6 - 14.4	8.5	96	48	150	15-17.4	83/86
HWS150-12/A	12V	9.6 - 14.4	13	96	48	150	15-17.4	83/86
HWS15-15/A	15V	12.0 - 18.0	1	120	60	150	18.8-21.8	80/81
HWS30-15/A	15V	12.0 - 18.0	2	120	60	150	18.8-21.8	81/83
HWS50-15/A	15V	12.0 - 18.0	3.5	120	60	150	18.8-21.8	81/83
HWS100-15/A	15V	12.0 - 18.0	7	120	60	150	18.8-21.8	83/86
HWS150-15/A	15V	12.0 - 18.0	10	120	60	150	18.8-21.8	83/86
HWS15-24/A	24V	19.2 - 28.8	0.65	192	96	200	30-34.8	82/83
HWS30-24/A	24V	19.2 - 28.8	1.3	192	96	200	30-34.8	83/86
HWS50-24/A	24V	19.2 - 28.8	2.2	192	96	150	30-34.8	82/84
HWS100-24/A	24V	19.2 - 28.8	4.5	192	96	150	30-34.8	84/87
HWS150-24/A	24V	19.2 - 28.8	6.5	192	96	150	30-34.8	85/88
HWS15-48/A	48V	38.4 - 52.8	0.33	384	192	200	55.2-64.8	80/80
HWS30-48/A	48V	38.4 - 52.8	0.65	384	192	200	55.2-64.8	82/83
HWS50-48/A	48V	38.4 - 52.8	1.1	384	192	200	55.2-64.8	83/85
HWS100-48/A	48V	38.4 - 52.8	2.1	384	192	200	55.2-64.8	84/87
HWS150-48/A	48V	38.4 - 52.8	3.3	384	192	200	55.2-64.8	85/88

Outline Drawing HWS15 Series

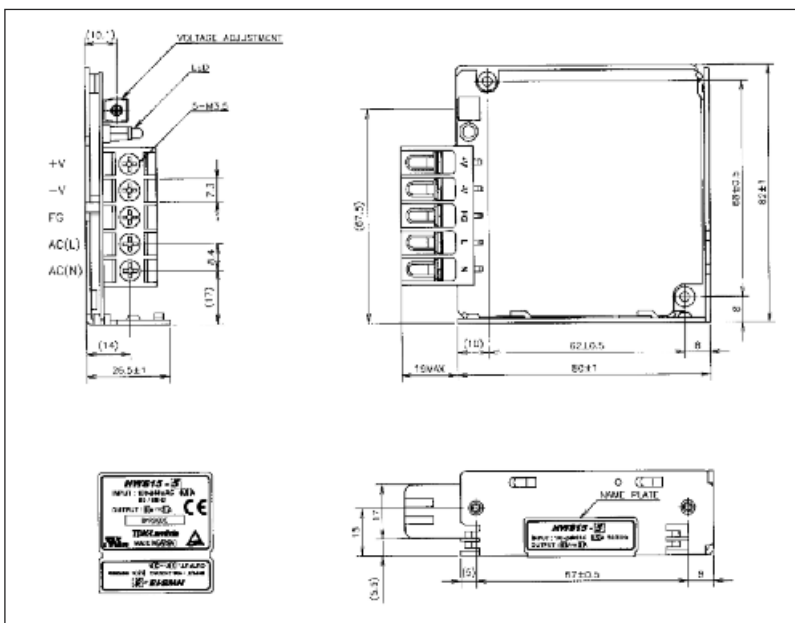

Options

Suffix	Description
Blank	Screw terminals, no cover
/A	Screw terminals, cover
/ADIN	Cover and DinRail Mounting Bracket (24V Models only)
/R	Remote on/off (50-150W only) Example: HWS50-24/RA



Outline Drawing HWS30 Series

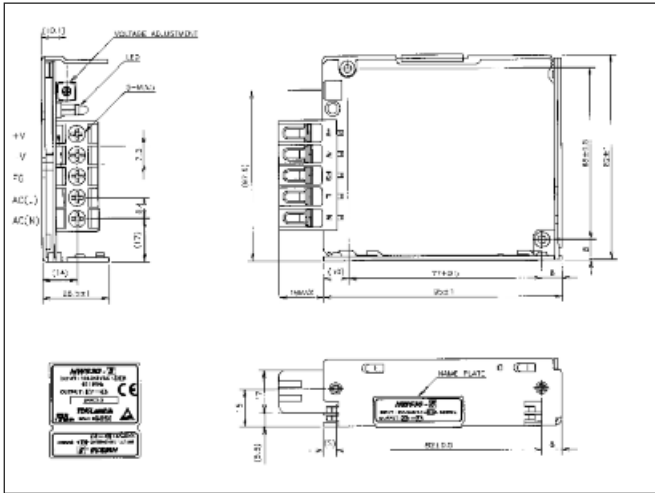

Outline Drawing HWS50 Series

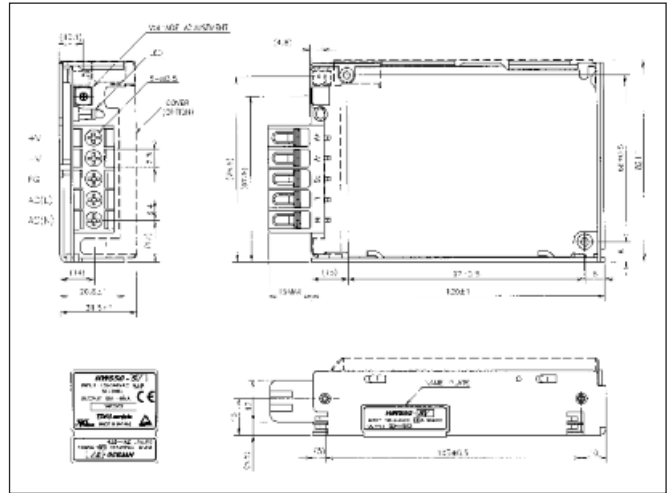

Outline Drawing HWS100 Series

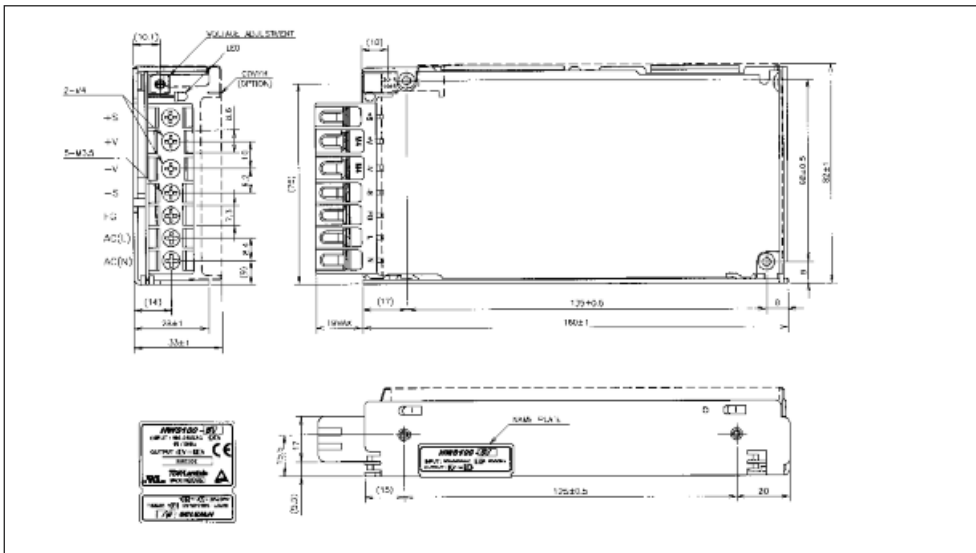

Outline Drawing HWS150 Series

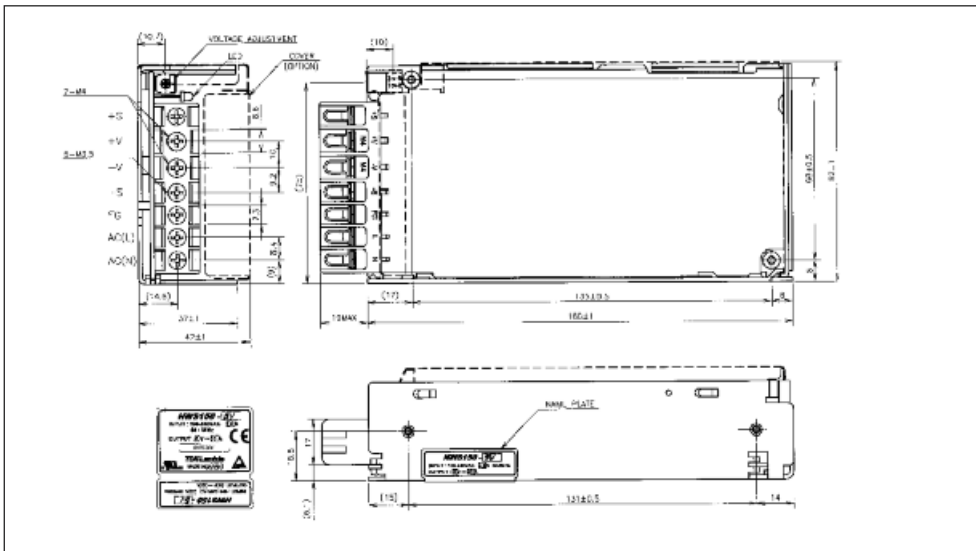

Note: All fixing holes M3 tapped max. depth 6mm

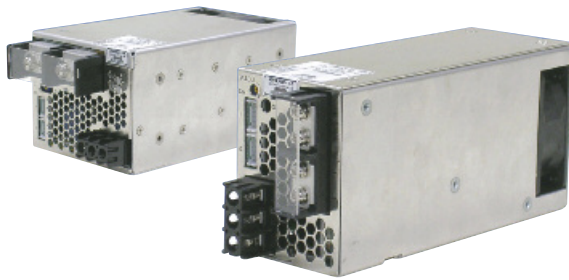

- Lifetime Warranty
- UL508 Approved
- SEMI F47 Compliant (high line AC)
- Universal Input (85 - 265VAC)
- High Efficiency
- RoHS Compliant Design

HWS300-1500 Series

Single Output Industrial Power Supplies

Key Market Segments & Applications

- Factory Automation
- Test & Measurement
- Automated Service

HWS300-1500 Features and Benefits

Features

- Lifetime Warranty
- High Efficiency
- Wide Range AC Input

Benefits

- Lower Cost of Ownership
- Easier System Cooling
- Supports Global Use

Specifications

MODEL		HWS300	HWS600	HWS1000	HWS1500
ITEMS					
Input Voltage range (47-63Hz)	-	85 - 265VAC or 120 - 330VDC			
Input Current (Typ)	(1) A	5V: 3.8/1.9; 12-48V: 4.2/2.1	5V: 7.5/3.6; 12-48V: 8.1/3.9	3.3V: 9.6/5.0; 5-60V: 13.5/7.0	3.3V: 15/8 5-60V: 19/10
Inrush Current	(1) A	20 / 40			
Power Factor	-	Meets EN61000-3-2			
Temperature Coefficient	-	<0.02%/°C			
Overcurrent Protection	-	>105% (>101% of peak current for peak current capable models)			
Overvoltage Protection	V	See table on page 2 (Recycle AC or remote on/off to reset)			
Hold Up Time (Typ)	ms	20 (HWS1500-7 - 16ms)			
Leakage Curr. (at 240VAC, 60Hz)	mA	<0.75mA		<1.2mA	<1.5mA
Remote Sense	-	Yes			
Indicator	-	Green LED = ON			
Remote on/off	-	Yes (Isolated from output)			
Parallel operation	-	Single wire connection (up to 5 units)			
DC Good	-	Yes			
Remote Adjust (PV)	-	External voltage adjusts output, see options table			
Operating Temperature	°C	-10 to +70°C, derate linearly to 50% load from 50 to 70 (2, 3)			
Storage Temperature	°C	-30 to +85°C			
Humidity (non condensing)	-	Operating: 10 - 90%RH, Non operating 10 - 95%RH			
Cooling	-	Internal fan			
Withstand Voltage	(4) -	Input to Ground 2.5kVAC, Input to Output 3kVAC, Output to Ground 500VAC for 1 min.			
Isolation Resistance	-	>100MΩ at 25°C & 70%RH, Output to Ground 500VDC			
Vibration (non operating)	-	10 - 55Hz (1 minute sweep), 19.6m/s ² constant X, Y, Z 1 hour			
Shock	-	< 196.1 m/s ²			
Safety Agency Approvals	(5) -	UL60950-1, CSA60950-1, EN60950-1, EN50178, UL508, CE Mark			
Line Dip	-	Complies with SEMI F47 (200VAC line only)			
Conducted & Radiated EMI	-	EN55011 / EN55022, FCC VCCI (HWS300, 600 & 1000: Class B, HWS1500: Class A)			
Recommended EMI Filter	-	MC1206	MC1210	MC1220	MC1230
Immunity	-	IEC61000-4-2, -3, -4, -6 (Level 3), -5, -8 (Level 4), -11			
Weight (Typ)	g	1,000	1,600	3,200	3,800
Size	mm	61 x 82 x 165	100 x 82 x 165	240 x 126.5 x 82	280 x 126.5 x 82
Warranty		Lifetime Warranty (See TDK-Lambda's terms & conditions)			



Model Selector

Model	Voltage V	Adjust Range V(3)	Max Curr. A	Peak Curr. A(2)	Max. Pwr. W	Peak Power W	Load Reg mV	Line Reg mV	Ripple Noise mV	Over-voltage V	Eff. typ % (1)
HWS300-3	3.3V	2.64 - 3.96	60	-	198		30	20	120	4.13 - 4.95	74/77
HWS600-3	3.3V	2.64 - 3.96	120	-	396		30	20	120	4.13 - 4.95	75/78
HWS1000-3	3.3V	2.64 - 3.96	200		660		40	20	120	4.13 - 4.62	71/73
HWS1500-3	3.3V	2.64 - 3.96	300		990		60	36	150	4.12 - 4.62	72/75
HWS300-5	5V	4 - 6	60	-	300		30	20	120	6.25 - 7.25	79/82
HWS600-5	5V	4 - 6	120	-	600		30	20	120	6.25 - 7.25	80/83
HWS1000-5	5V	4 - 6	200		1000		40	20	120	6.25 - 7	76/78
HWS1500-5	5V	4 - 6	300		1500		60	36	150	4.0 - 6.0	77/81
HWS1000-6	6V	4.8 - 7.2	167		1002		60	36	150	7.5 - 8.4	79/81
HWS1500-6	6V	4.8 - 7.2	250	300	1500	1800	60	40	150	4.8 - 7.2	79/82
HWS1000-7	7.5V	6 - 9V	134	160	1005	1200	60	36	150	9.38 - 10.5	80/82
HWS1500-7	7.5V	6 - 9V	200	240	1500	1800	60	40	150	6.0 - 9.0	81/83
HWS300-12	12V	9.6 - 14.4	27	-	324		72	48	150	15 - 17.4	80/83
HWS600-12	12V	9.6 - 14.4	53	-	636		72	48	150	15 - 17.4	80/83
HWS1000-12	12V	9.6 - 14.4	88	100	1056	1200	100	48	150	15 - 17.4	82/85
HWS1500-12	12V	9.6 - 14.4	125	-	1500		72	48	150	15 - 17.4	82/85
HWS300-15	15V	12 - 18	22	-	330		90	60	150	18.8 - 21.8	80/83
HWS600-15	15V	12 - 18	43	-	645		90	60	150	18.8 - 21.8	81/84
HWS1000-15	15V	12 - 18	70	80	1050	1200	120	60	150	18.8 - 21.8	83/85
HWS1500-15	15V	12 - 18	100	-	1500		90	60	150	18.7 - 21.8	83/87
HWS300-24	24V	19.2 - 28.8	14	16.5	336	396	144	96	150	30 - 34.8	82/85
HWS600-24	24V	19.2 - 28.8	27	31	648	744	144	96	150	30 - 34.8	82/85
HWS1000-24	24V	19.2 - 28.8	46	58.5	1104	1404	150	96	150	30 - 34.8	85/87
HWS1500-24	24V	19.2 - 28.8	65/70 (1)	105	1560	2520	144	96	200	30 - 34.8	84/88
HWS1000-36	36V	28.8 - 43.2	30.7	39	1104	1404	150	144	200	45 - 49.7	85/88
HWS1500-36	36V	28.8 - 43.2	42/46.5 (1)	70	1512	2520	150	144	200	45 - 49.7	84/88
HWS300-48	48V	38.4 - 52.8	7	-	336		288	192	350	55.2 - 64.8	82/85
HWS600-48	48V	38.4 - 52.8	13	-	624		288	192	350	55.2 - 64.8	83/86
HWS1000-48	48V	38.4 - 52.8	23	29	1104	1404	300	192	200	55.2 - 64.8	86/88
HWS1500-48	48V	38.4 - 52.8	32	-	1536		288	192	200	55.2 - 64.8	86/90
HWS1000-60	60V	48 - 66	18.4	23.4	1104	1404	360	240	400	69 - 75	85/88
HWS1500-60	60V	48 - 66	28	42	1536	2520	360	240	400	69 - 75	86/90

Notes

- (1) 100/200VAC
- (2) 200-265VAC Input, 10s maximum on time with 35% duty cycle
- (3) Use program input (PV) to adjust from 20-120% of nominal (20-110% for 48V models)

Options

Suffix	Description
Blank	HWS300-1500 the cover is fitted as standard
/A	Not Applicable HWS300-1500 the cover is fitted as standard
/PV	HWS300, 600 (Standard on HWS1000 & 1500 all output voltages): 1-6V program voltage input to adjust output 20-120% of nominal (20-110% for 48V) (12V-48V models only for 300 & 600W):
/HD	See HWS30-1500/HD Datasheet for details. -40 to +71(74)°C operation, conformally coated PCBs
/ME	See HWS30-1500/ME Datasheet for details. UL60601-1, EN60601-1 medical approvals

Specification Notes (See Page 1):

- (1) 100/200VAC
- (2) HWS start up -20°C. (-40°C see options table)
- (3) HWS1000/1500 with 85VAC input:
See installation manual
HWS1000: -10 to +71°C.
HWS1000-5 derate linearly above 40°C
- (4) 2kVAC HWS1000/1500 Input to ground
- (5) UL60601-1, EN60601-1, see options.
UL508; HWS300/600 5V, 12V, 24V & 48V models



Outline Drawing HWS300 -1500 Series

HWS300
Notes

A: Model name, nominal output voltage and maximum output current are shown in the name plate in accordance with the specifications.

B: M4 tapped holes (8) for customer chassis mounting. (Screw penetration depth 6mm maximum.)

HWS600
Notes

A: Model name, nominal output voltage and maximum output current are shown in the name plate in accordance with the specifications.

B: M4 tapped holes (8) for customer chassis mounting. (Screw penetration depth 6mm maximum.)

HWS1000 Notes

A: Model name, nominal output voltage and maximum output current are shown in the name plate in accordance with the specifications.

B: Country of manufacture is shown here.

C: M4 tapped holes (16) for customer chassis mounting. (Screws must not protrude into power supply by more than 6mm.)

D: I/O Signal Connector.

Connector:	S12B-PHDSS(LF)(SN)	(JST)
Matching Housing:	PHDR-12VS	(JST)
Matching Contact:	SPHD-002T-P0.5(AWG28-24)	(JST) or
	SPHD-001T-P0.5(AWG26-22)	(JST) or
	BPHD-001T-P0.5(AWG26-22)	(JST)
Hand Crimping Tool:	YRS-620(SPHD-002T-P0.5)	(JST)
	YC-610R(SPHD-001T-P0.5)	(JST)
	YC-610R(BPHD-001T-P0.5)	(JST)

E: Recommended torque for the terminal piece

Input terminal (M4 screw):	1.27N·m
Output terminal (M8 bolt & nut):	10.8N·m
Output terminal (M4 screw):	1.27N·m

HWS1500 Notes

A: Model name, option, input voltage range, nominal output voltage, maximum output current are shown in the name plate in accordance with the specifications.

B: Country of manufacture is shown here.

C: M4 tapped holes (16) for customer chassis mounting. (Screws must not protrude into power supply by more than 6mm.) Recommended M4 screws torque: 1.27N·m

D: I/O Signal Connector.

Connector:	S12B-PHDSS(LF)(SN)	(JST)
Matching Housing:	PHDR-12VS	(JST)
Matching Contact:	SPHD-002T-P0.5(AWG28-24)	(JST) or
	SPHD-001T-P0.5(AWG26-22)	(JST) or
	BPHD-001T-P0.5(AWG26-22)	(JST)
Hand Crimping Tool:	YRS-620(SPHD-002T-P0.5)	(JST)
	YC-610R(SPHD-001T-P0.5)	(JST)
	YC-610R(BPHD-001T-P0.5)	(JST)

E: Recommended torque for the terminal piece

Input terminal (M4 screw):	1.27N·m
Output terminal (M8 bolt & nut):	10.8N·m
Output terminal (M4 screw):	1.27N·m



- Lifetime Warranty
- -10 to +71°C Operation (-40°C start up)
- Universal Input (85 - 265VAC)
- Conformally coated PCB's
- RoHS Compliant Design

HWS30-1500/HD Series

Single Output Industrial Power Supplies

Key Market Segments & Applications

- Factory Automation
- Test & Measurement
- LED Displays

HWS30-1500/HD Features and Benefits

Features

- Lifetime Warranty
- Conformally coated PCB's
- Wide Range AC Input

Benefits

- Lower Cost of Ownership
- Operates in Harsh Environments
- Supports Global Use

Specifications

MODELS		HWS30 HWS50	HWS100 HWS150	HWS300	HWS600	HWS1000	HWS1500	
ITEMS								
Input Voltage range (47-63Hz)		85 - 265VAC or 120 - 370VDC			85 - 265VAC or 120 - 330VDC			
Input Current (Typ)	(1)	A	0.8 / 0.4 0.7 / 0.35	1.3 / 0.65 1.9 / 0.95	4.1 / 2.1	8.1 / 3.9	13.5 / 7.0 19 / 10	
Inrush Current	(1)	A	14 / 28		20 / 40			
Power Factor	-	Meets EN61000-3-2						
Temperature Coefficient	-	<0.02%/°C						
Overcurrent Protection	-	>104%						
Overvoltage Protection	V	Yes (See table on page 2)						
Hold Up Time (Typ)	ms	20						
Leakage Current (60Hz)	mA	<0.5mA		<0.75mA		<1.2mA	≤1.5mA	
Remote Sense	-	No		Yes				
Indicator	-	Green LED = ON						
Remote On/Off	-	No		Yes (Isolated from output)				
Parallel operation	-	No		Single wire connection (5 units max)				
DC Good	-	No		Yes				
Operating Temperature & Derating (operation to +74°C - contact factory)		HWS30-150: -10°C to +71°C, (-10 to +50°C: 100%, +60°C: 60%, +71°C: 20%) HWS300-1500: -10°C to +71°C, (-10 to +50°C: 100%, derate linearly to 50% load from +50 to +71°C) Guaranteed start up at -40°C (see specification sheets on website for details and derating)						
Storage Temperature		-40°C to +85°C						
Humidity (non condensing)	-	Operating: 30-90%RH (10 - 90% on HWS300-1500), Non operating 10-95%RH						
Cooling	-	Convection			Internal fan			
Withstand Voltage (2)	-	Input to Ground 2kVAC, Input to Output 3kVAC, Output to Ground 500VAC for 1 min.						
Isolation Resistance	-	>100MΩ at 25°C & 70%RH, Output to Ground 500VDC, >10MΩ Output to remote on/off 100VDC						
Vibration (non operating)	-	MIL-STD-810F 514.5 Category 4, 10						
Shock (in packaging)	-	MIL-STD-810F 516.5 Procedure I, VI (<196.1m/s ²)						
Safety Agency Approvals	-	UL60950-1, CSA60950-1, EN60950-1, EN50178, CE Mark						
Line Dip	-	Complies with SEMI F47 (200VAC line only)						
Conducted & Radiated EMI	-	EN55011 / EN55022-B, FCC-B, VCCI-B (Curve A for HWS1500)						
Immunity	-	IEC61000-4-2 (Level 2,3), -3, -4, -6, (Level 3), -5, -8 (Level 4), -11						
Weight (Typ)	g	220 280	450 500	1000	1600	3200	3800	
Size (WxHxD)	mm	26.5 x 82 x 95 26 x 82 x 120	28 x 82 x 160 37 x 82 x 160	61 X 82 X 165	100 X 82 X 165	126.5 X 82 X 240	126.5 X 82 X 280	
Warranty		Lifetime Warranty (See TDK-Lambda's terms & conditions)						

Notes: (1) 100/200VAC input. (2) HWS300-600 2.5kVAC Input to ground



Model Selector

Model	Voltage (V)	Adjust Range (V)	Max Curr. (A)	Peak ⁽³⁾ Curr. (A)	Max. Power (W)	Peak ⁽³⁾ Power (W)	Load Reg (mV)	Line Reg (mV)	Ripple Noise (mV)	Over voltage (V)	Efficiency ⁽¹⁾ typ %
HWS50-3/HD	3.3	2.97 - 3.96	6		20		40	20	120	4.13 - 4.95	70/73
HWS50-3/HD	3.3	2.97 - 3.96	10		33		40	20	120	4.13 - 4.95	76/78
HWS100-3/HD	3.3	2.97 - 3.96	20		66		40	20	120	4.13 - 4.95	78/81
HWS150-3/HD	3.3	2.97 - 3.96	30		99		40	20	120	4.13 - 4.95	78/81
HWS300-3/HD	3.3	2.64 - 3.96	60		198		30	20	120	4.13 - 4.95	74/77
HWS600-3/HD	3.3	2.64 - 3.96	120		396		30	20	120	4.13 - 4.95	75/78
HWS1000-3/HD	3.3	2.64 - 3.96	200		660		40	20	120	4.12 - 4.62	71/73
HWS1500-3/HD	3.3	2.64 - 3.96	300		990		60	36	200	4.12 - 4.62	72/75
HWS30-5/HD	5	4.0 - 6.0	6		30		40	20	120	6.25 - 7.25	77/80
HWS50-5/HD	5	4.0 - 6.0	10		50		40	20	120	6.25 - 7.25	82/84
HWS100-5/HD	5	4.0 - 6.0	20		100		40	20	120	6.25 - 7.25	83/86
HWS150-5/HD	5	4.0 - 6.0	30		150		40	20	120	6.25 - 7.25	83/86
HWS300-5/HD	5	4.0 - 6.0	60		300		30	20	120	6.25 - 7.25	79/82
HWS600-5/HD	5	4.0 - 6.0	120		600		30	20	120	6.25 - 7.25	80/83
HWS1000-5/HD	5	4.0 - 6.0	200		1000		30	20	120	6.25 - 7.0	76/78
HWS1500-5/HD	5	4.0 - 6.0	300		1500		60	36	200	6.25 - 7.0	77/81
HWS1000-6/HD	6	4.8 - 7.2	167		1002		30	20	150	7.5 - 8.4	79/81
HWS1500-6/HD	6	4.8 - 7.2	250	300	1500	1800	60	36	200	6.25 - 7.0	79/82
HWS1000-7/HD	7.5	6.0 - 9.0	134	160	1005	1200	30	20	150	9.37 - 10.5	80/82
HWS1500-7/HD	7.5	6.0 - 9.0	200	240	1500	1800	60	40	200	9.37 - 10.5	81/83
HWS30-12/HD	12	9.6 - 14.4	2.5		30		96	48	150	15.0 - 17.4	81/83
HWS50-12/HD	12	9.6 - 14.4	4.3		51.6		96	48	150	15 - 17.4	81/83
HWS100-12/HD	12	9.6 - 14.4	8.5		102		96	48	150	15 - 17.4	83/86
HWS150-12/HD	12	9.6 - 14.4	13		156		96	48	150	15 - 17.4	83/86
HWS300-12/HD	12	9.6 - 14.4	27		324		72	48	150	15 - 17.4	80/83
HWS600-12/HD	12	9.6 - 14.4	53		636		72	48	150	15 - 17.4	80/83
HWS1000-12/HD	12	9.6 - 14.4	88	100	1056	1200	72	48	150	15 - 17.4	82/85
HWS1500-12/HD	12	9.6 - 14.4	125		1500		72	48	150	15 - 17.4	82/85
HWS30-15/HD	15	12.0 - 18.0	2		30		120	60	150	18.8 - 21.8	81/84
HWS50-15/HD	15	12.0 - 18.0	3.5		52.5		120	60	150	18.8 - 21.8	81/83
HWS100-15/HD	15	12.0 - 18.0	7		105		120	60	150	18.8 - 21.8	83/86
HWS150-15/HD	15	12.0 - 18.0	10		150		120	60	150	18.8 - 21.8	83/86
HWS300-15/HD	15	12.0 - 18.0	22		330		90	60	150	18.8 - 21.8	80/83
HWS600-15/HD	15	12.0 - 18.0	43		645		90	60	150	18.8 - 21.8	81/84
HWS1000-15/HD	15	12.0 - 18.0	70	80	1050	1200	90	60	150	18.7 - 21.8	83/85
HWS1500-15/HD	15	12.0 - 18.0	100		1500		90	60	150	18.7-21.8	83/87
HWS30-24/HD	24	19.2 - 28.8	1.3		31.2		192	96	200	30 - 34.8	83/86
HWS50-24/HD	24	19.2 - 28.8	2.2		52.8		192	96	150	30 - 34.8	82/84
HWS100-24/HD	24	19.2 - 28.8	4.5		108		192	96	150	30 - 34.8	84/87
HWS150-24/HD	24	19.2 - 28.8	6.5		156		192	96	150	30 - 34.8	85/88
HWS300-24/HD	24	19.2 - 28.8	14	16.5	336	396	144	96	150	30 - 34.8	82/85
HWS600-24/HD	24	19.2 - 28.8	27	31	648	744	144	96	150	30 - 34.8	82/85
HWS1000-24/HD	24	19.2 - 28.8	46	58.5	1104	1404	144	96	150	30 - 34.8	85/87
HWS1500-24/HD	24	19.2 - 28.8	65/70	105	1560/1680	2520 ⁽¹⁾	144	96	200	30 - 34.8	84/88
HWS1000-36/HD	36	28.8 - 43.2	30.7	39	1104	1404	150	144	200	45 - 49.7	85/88
HWS1500-36/HD	36	28.8 - 43.2	42/46.5	70	1512/1674	2520 ⁽¹⁾	150	144	200	45 - 49.7	84/88
HWS30-48/HD	48	38.4 - 52.8	0.65		31.2		384	192	200	55.2 - 64.8	82/83
HWS50-48/HD	48	38.4 - 52.8	1.1		52.8		384	192	200	55.2 - 64.8	83/85
HWS100-48/HD	48	38.4 - 52.8	2.1		100.8		384	192	200	55.2 - 64.8	84/87
HWS150-48/HD	48	38.4 - 52.8	3.3		158.4		384	192	200	55.2 - 64.8	85/88
HWS300-48/HD	48	38.4 - 52.8	7		336		288	192	350	55.2 - 64.8	82/85
HWS600-48/HD	48	38.4 - 52.8	13		624		288	192	350	55.2 - 64.8	83/86
HWS1000-48/HD	48	38.4 - 52.8	23	29.2	1104	1404	288	192	200	55.2 - 60.0	86/88
HWS1500-48/HD	48	38.4 - 52.8	32		1536		288	192	200	55.2 - 64.8	86/90
HWS1000-60/HD	60	48.0 - 66	18.4	23.4	1104	1404	360	240	400	69.0 - 75.0	85/88
HWS1500-60/HD	60	48.0 - 66	28	42	1536	2520	360	240	400	69.0 - 75.0	86/90

Options

Suffix	Description
Blank	No cover (except HWS300-1500 cover fitted as standard)
/A	Cover fitted (eg HWS100-24/HDA) Deratings apply

Notes: (3) Peak load for 10s maximum on time, 35% duty cycle at >200V input



Outline Drawing HWS30 Series

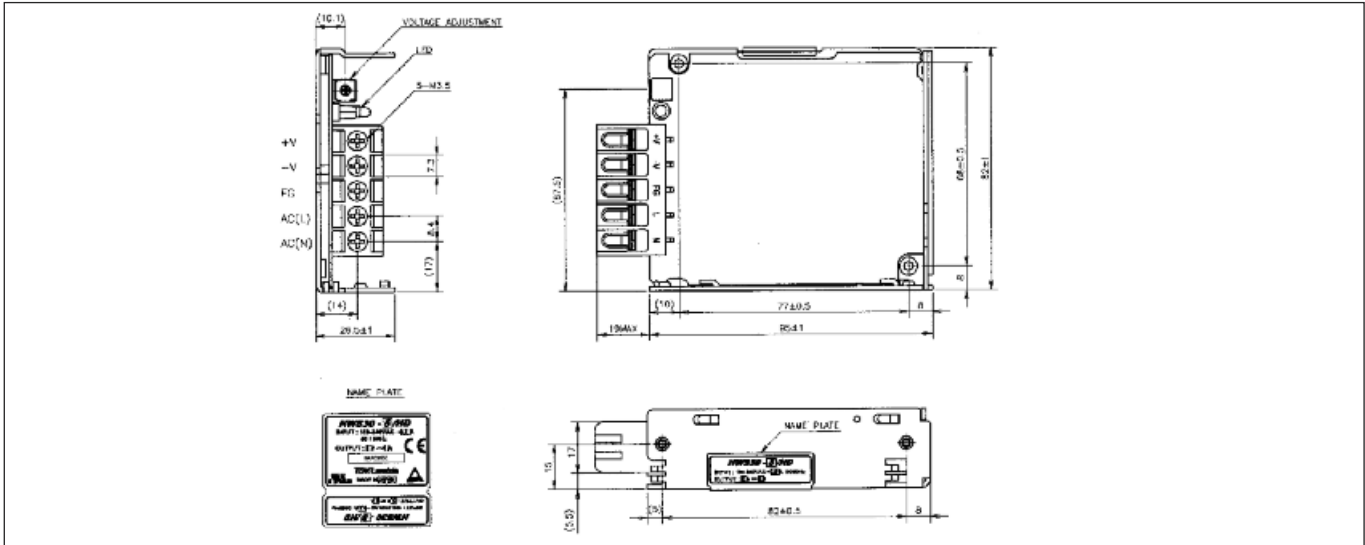

Outline Drawing HWS150 Series

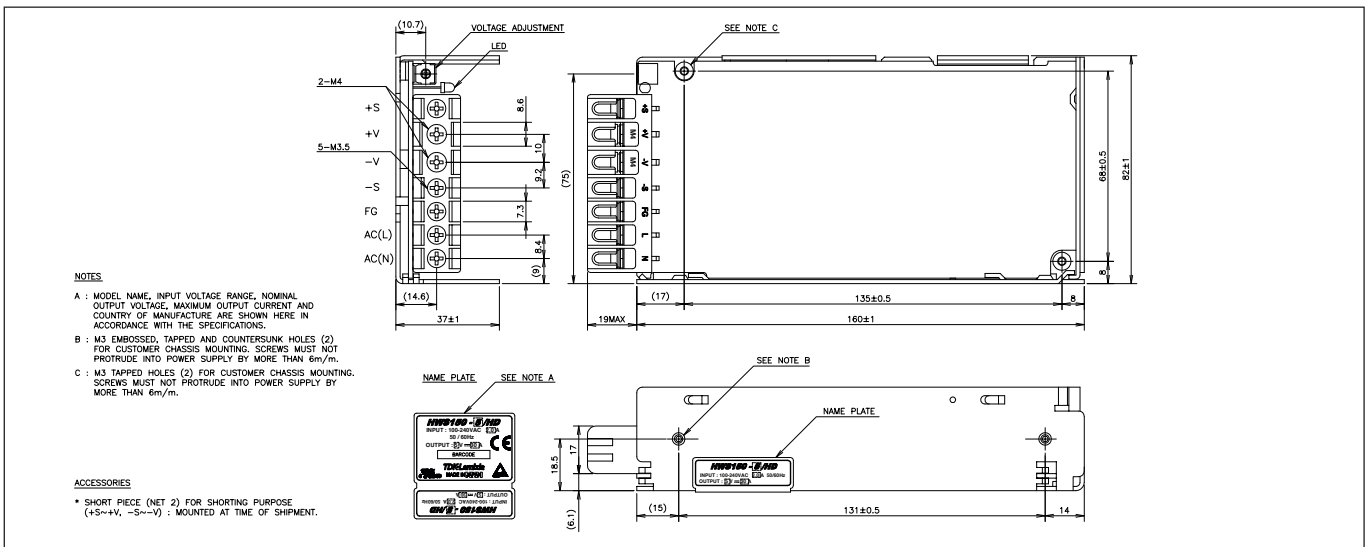

Outline Drawing HWS1500 Series

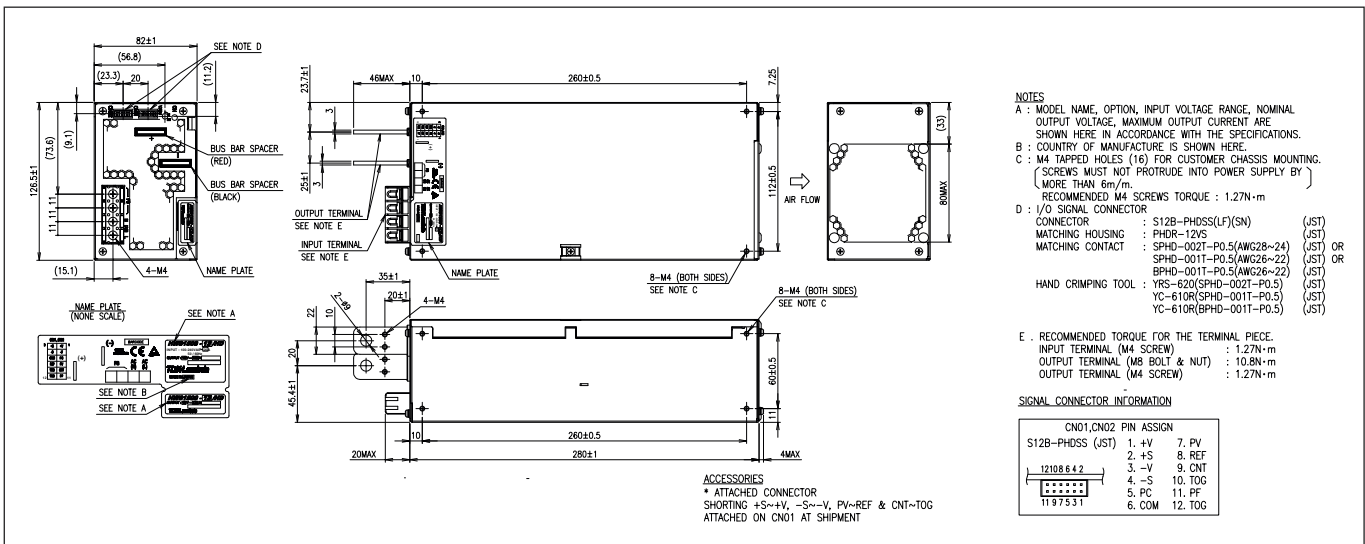



- Lifetime Warranty
- Medical Approvals
- Universal Input (85 - 265VAC)
- High Efficiency
- Broad 30W to 1500W product range
- RoHS Compliant Design

HWS30-1500/ME Series

Single Output
Medical Power Supplies

Key Market Segments & Applications

Non-Surgical Medical Equipment
Analysers

HWS30-1500/ME Features and Benefits

Features

- Lifetime Warranty
- Medical Approvals
- Wide Range AC Input

Benefits

- Lower Cost of Ownership
- Reduces System Approval Times
- Supports Global Use

Specifications

ITEM	MODELS		HWS30	HWS100	HWS300	HWS600	HWS1000	HWS1500
			HWS50	HWS150				
Input Voltage range			85-265VAC (47-63Hz) or 120-370VDC		85-265VAC (47-330VDC)		85-265VAC (47-63Hz)	
Input Current (Typ)	(1)	A	0.8 / 0.4	1.3 / 0.65	4.1 / 2.1	8.1 / 3.9	13.5/7.0	19/10
Inrush Current	(1)	A	14 / 28		20 / 40			
Power Factor / Flicker			Meets EN61000-3-2, EN61000-3-3					
Temperature Coefficient	-		<0.02%/°C					
Overcurrent Protection	-		>104%					
Overvoltage Protection	V		Yes (See table on page 2)					
Hold Up Time (Typ)		ms	20					
Leakage Current (60Hz)	(2)	mA	<0.5mA					
Remote Sense			No			Yes		
Indicator	-		Green LED = ON					
Remote On/Off	-		No			Yes (Isolated from output)		
Parallel operation	-		No			Single wire conn. (5 units max)		
DC Good	-		No			Yes		
Voltage Programming			No					Yes
Operating Temperature and Derating	-		HWS30-150: -10°C to +70°C, (-10 to +50°C: 100%, +60°C: 60%, +70°C: 20%) HWS300-1500: -10°C to +70°C, (-10 to +50°C: 100%, derate linearly to 50% load from +50°C to +70°C)					
Storage Temperature	°C		-30°C to +85°C					
Humidity (non condensing)	-		Operating: 30 - 90%RH (10 -90% on HWS300-1500), Non operating 10 - 95%RH					
Cooling	-		Convection			Internal fan		
Withstand Voltage	(3)	-	Input to Ground 2kVAC, Input to Output 3kVAC, Output to Ground 500VAC for 1 min.					
Isolation Resistance	-		>100MΩ at 25°C & 70%RH, Output to Ground 500VDC, >10MΩ Output to remote on/off 100VDC					
Vibration (non operating)	-		10 - 55Hz (1 min sweep), 19.6m/s ² constant, X, Y, Z axis, one hour each					
Shock (in packaging)	-		< 196.1m/s ²					
Safety Agency Approvals	(2)	-	UL60601-1, EN60601-1, CSA-C22.2 No6011-M90 (C-UL) (basic insulation), CE Mark					
Line Dip	-		Complies with SEMI F47 (200VAC line only)					
Conducted & Radiated EMI	-		EN55011 / EN55022-B, FCC-B, VCCI-B (HWS600 & 1500 Class A)					
Immunity	-		IEC61000-4-2 (Level 2,3), -3, -4, -6, (Level 3), -5 (Level 3,4), -11					
Weight (Typ)	g		220 280	450 500	1000	1600	3200	3800
Size (WxHxD)	mm		26 x 82 x 95 26 x 82 x 120	28 x 82 x 160 37 x 82 x 160	61 x 82 x 165	100 x 82 x 165	126.5 x 82 x 240	280 x 82 x 126.5
Warranty			Lifetime Warranty (See TDK-Lambda's terms & conditions)					

Notes: (1) 100/200VAC input (2) See clause 19.5DV.2 of UL60601 for equipment in proximity of patient (3) HWS300-600 2.5kVAC Input to ground



Model Selector									
Model	Voltage	Adjust Range	Max Curr(A) ⁴	Max Power(W)	Load Reg(mV)	Line Reg(mV)	Ripple Noise(mV)	Overvoltage (V)	Efficiency (typ)% ¹
HWS30-5/ME	5V	4.0 - 6.0	6	30	40	20	120	6.25-7.25	77/80
HWS50-5/ME	5V	4.0 - 6.0	10	50	40	20	120	6.25-7.25	82/84
HWS100-5/ME	5V	4.0 - 6.0	20	100	40	20	120	6.25-7.25	83/86
HWS150-5/ME	5V	4.0 - 6.0	30	150	40	20	120	6.25-7.25	83/86
HWS600-5/ME	5V	4.0 - 6.0	120	600	30	20	120	6.25-7.25	80/83
HWS30-12/ME	12V	9.6 - 14.4	2.5	30	96	48	150	15-17.4	81/83
HWS50-12/ME	12V	9.6 - 14.4	4.3	51.6	96	48	150	15-17.4	81/83
HWS100-12/ME	12V	9.6 - 14.4	8.5	102	96	48	150	15-17.4	83/86
HWS150-12/ME	12V	9.6 - 14.4	13	156	96	48	150	15-17.4	83/86
HWS300-12/ME	12V	9.6 - 14.4	27	324	72	48	150	15-17.4	80/83
HWS600-12/ME	12V	9.6 - 14.4	53	636	72	48	150	15-17.4	80/83
HWS30-15/ME	15V	12.0 - 18.0	2	30	120	60	150	18.8-21.8	81/83
HWS50-15/ME	15V	12.0 - 18.0	3.5	52.5	120	60	150	18.8-21.8	81/83
HWS100-15/ME	15V	12.0 - 18.0	7	105	120	60	150	18.8-21.8	83/86
HWS150-15/ME	15V	12.0 - 18.0	10	150	120	60	150	18.8-21.8	83/86
HWS300-15/ME ⁽⁵⁾	15V	12.0 - 18.0	22	330	90	60	150	18.8-21.8	82/85
HWS600-15/ME	15V	12.0 - 18.0	43	645	90	60	150	18.8-21.8	81/84
HWS30-24/ME	24V	19.2 - 28.8	1.3	31.2	192	96	200	30-34.8	83/86
HWS50-24/ME	24V	19.2 - 28.8	2.2	52.8	192	96	150	30-34.8	82/84
HWS100-24/ME	24V	19.2 - 28.8	4.5	108	192	96	150	30-34.8	84/87
HWS150-24/ME	24V	19.2 - 28.8	6.5	156	192	96	150	30-34.8	85/88
HWS300-24/ME	24V	19.2 - 28.8	14 (16.5 pk)	336	144	96	150	30-34.8	82/85
HWS600-24/ME	24V	19.2 - 28.8	27 (31 pk)	648	144	96	150	30-34.8	82/85
HWS1000-24/ME	24V	19.2 - 28.8	46 (58.5 pk)	1104	150	96	150	30-34.8	85/87
HWS1500-24/ME	24V	4.8 - 28.8 ⁽⁷⁾	65/70 ⁽¹⁾ (105pk ⁽⁶⁾)	1560/1680 ⁽¹⁾ (2520 pk ⁽⁶⁾)	144	96	200	30-34.8	84/88
HWS1000-36/ME	36V	28.8 - 43.2	30.7 (39 pk)	1104	150	144	200	45-49.7	85/88
HWS1500-36/ME	36V	7.2 - 43.2 ⁽⁷⁾	42/46.5 ⁽¹⁾ (70 pk) ⁽⁶⁾	1512/1674 ⁽¹⁾ (2520 pk ⁽⁶⁾)	150	144	200	34-49.7	84/88
HWS30-48/ME	48V	38.4 - 52.8	0.65	31.2	384	192	200	55.2-64.8	82/83
HWS50-48/ME	48V	38.4 - 52.8	1.1	52.8	384	192	200	55.2-64.8	83/85
HWS100-48/ME	48V	38.4 - 52.8	2.1	100.8	384	192	200	55.2-64.8	84/87
HWS150-48/ME	48V	38.4 - 52.8	3.3	158.4	384	192	200	55.2-64.8	85/88
HWS300-48/ME	48V	38.4 - 52.8	7	336	288	192	350	55.2-64.8	82/85
HWS600-48/ME	48V	38.4 - 52.8	13	624	288	192	350	55.2-64.8	83/86
HWS1000-48/ME	48V	38.4 - 52.8	23	1104	300	192	200	55.2-60	86/88
HWS1500-48/ME	48V	9.6 - 52.8 ⁽⁷⁾	32	1536	288	192	200	55.2-64.8	86/90

(4) Peak load for 10s maximum on time, 35% duty cycle
 (6) 200-265AC Input

(5) Safety Agency in progress - contact factory for status
 (7) Using voltage programming input - see installation manual for details

Options	
Suffix	Description
Blank	No cover (except HWS300-1500 cover fitted) as standard
/A	Cover fitted (egHWS100-24/MEA) option available for HWS100 & HWS150 only



Outline Drawing HWS100 Series

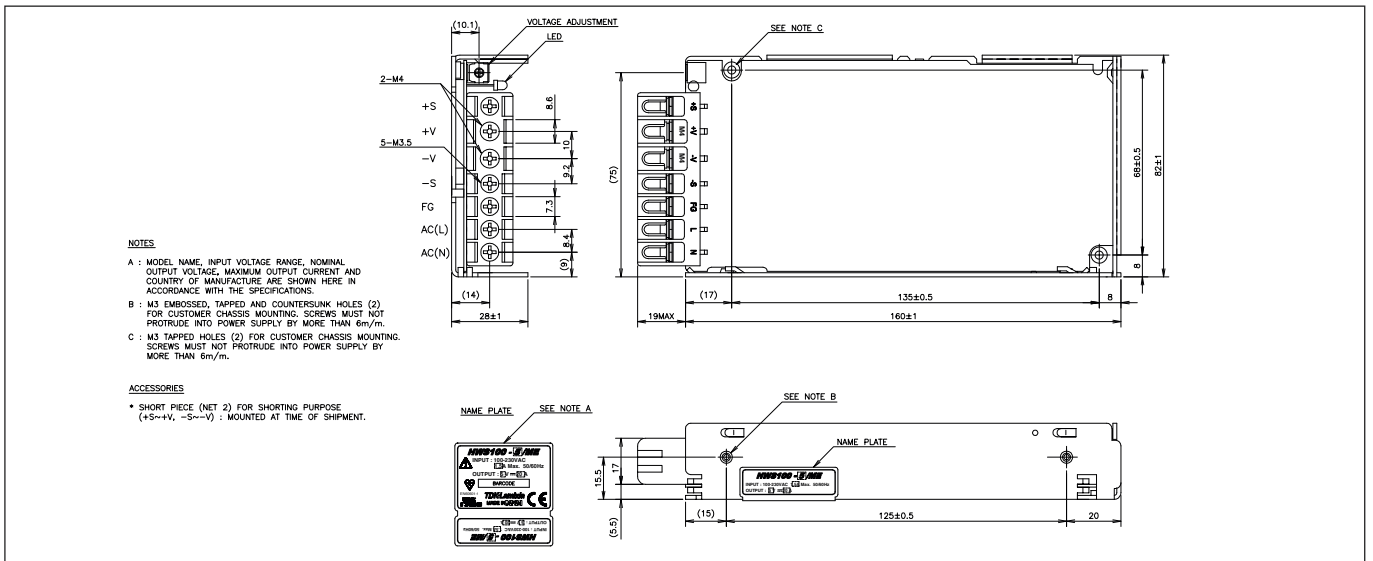

Outline Drawing HWS300 Series

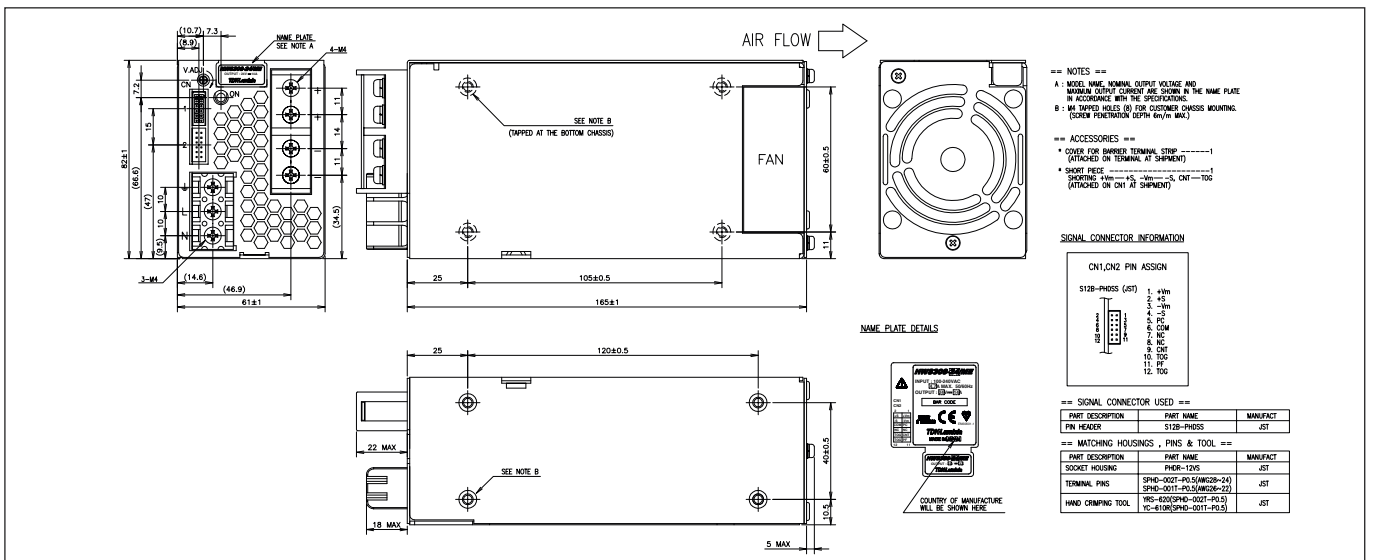

Outline Drawing HWS1500 Series

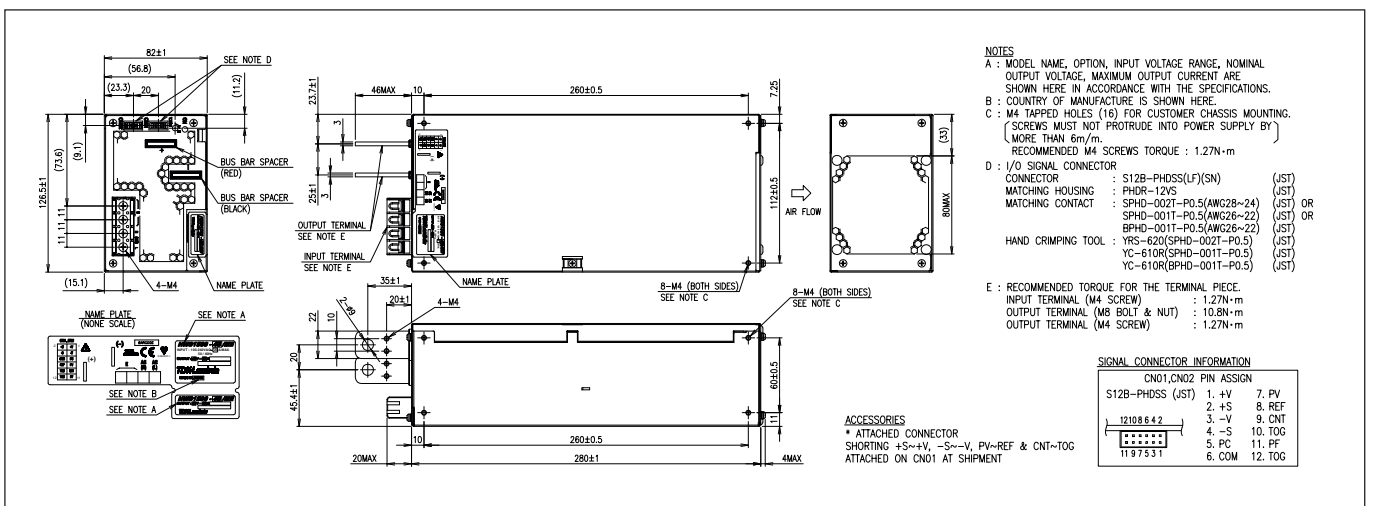



- Lifetime Warranty
- 300% Peak Power Capability
- Small Package Size
- Universal Input (85 - 265VAC)
- High Efficiency

Key Market Segments & Applications

- Factory Automation
- Process Control
- Semiconductor Fabrication
- Motor and Pump Drives

HWS300P & 600P Series

Peak Power Industrial Power Supplies

HWS300P & 600P Features and Benefits

Features

- Limited Lifetime Warranty
- Peak Power Capability
- High Efficiency

Benefits

- Lower Cost of Ownership
- Lower cost, smaller size
- Easier system cooling, less power used

Specifications

ITEMS	MODEL		HWS300P	HWS600P
Input Voltage range	-		85 - 265VAC (47 - 63Hz) or 120 - 330VDC	
Input Current (Typ)	(1)	A	3.6/1.9	7.2/3.7
Inrush Current	(1)	A	20 / 40	
Power Factor	-		Meets EN61000-3-2	
Temperature Coefficient	-		<0.02%/°C	
Overcurrent Protection	-		See table on page 2 (Recycle AC or remote on/off to reset)	
Overvoltage Protection	-	V	See table on page 2 (Recycle AC or remote on/off to reset)	
Hold Up Time (Typ)		ms	20	
Efficiency	(1)	%	84 / 87	
Leakage Curr. (@240VAC, 60Hz)		mA	<0.75mA (Typically 0.2mA at 100VAC)	
Remote Sense	-		No	
Indicator	-		Green LED = ON	
Remote on/off	-		Yes	
Line Regulation		mV	24V: 96mV, 36V: 144mV, 48V: 192mV	
Load Regulation		mV	24V: 144mV, 36V: 216mV, 48V: 288mV	
Ripple & Noise		mV	24V: 150mV, 36V: 200mV, 48V: 350mV	
Parallel operation	-		No	Yes, up to 2 units
DC Good	-		Yes	
Operating Temperature	-		-10°C to +70°C, derate linearly to 50% load from 50°C to 70°C	
Storage Temperature	-		-30°C to +85°C	
Humidity (non condensing)	-		Operating: 10 - 90%RH, Non operating 10 - 95%RH	
Cooling	-		Internal fan	
Withstand Voltage	-		Input to Ground 2.5kVAC, Input to Output 3kVAC, Output to Ground 500VAC for 1 min.	
Isolation Resistance	-		>100MΩ at 25°C & 70%RH, Output to Ground 500VDC	
Vibration (non operating)	-		10 - 55Hz (1 minute sweep), 19.6m/s ² constant X, Y, Z 1 hour	
Shock	-		< 196.1 m/s ²	
Safety Agency Certification	-		UL60950-1, CSA60950-1, EN60950-1, EN50178, CE Mark	
Line Dip	-		Complies with SEMI F47 (200VAC line only)	
Conducted & Radiated EMI	-		EN55011 / EN55022, FCC VCCI Class B	
Immunity	-		IEC61000-4-2, -3, -4, -6 (Level 3), -5, -8 (Level 4), -11	
Weight (Typ)		g	1,000	1,600
Size (WxHxD)		mm	61 x 82 x 165	100 x 82 x 165
Warranty	-		Lifetime Warranty (See TDK-Lambda's terms & conditions)	

Notes: (1) 100/200VAC



Model Selector

Model	Voltage V	Adjust Range V	Max Avg. Current A	Max Avg. Power W	Peak Current A (1,2)	Max Peak Power W (1)	Overcurrent Minimum A	Overvoltage V
HWS300P-24	24V	19.2 - 26.4	12.5	300	21 / 42	504 / 1008	21.4 / 42.8	27.6 - 32.4
HWS600P-24	24V	19.2 - 26.4	25	600	40.5 / 83	972 / 1992	41.3 / 84.6	27.6 - 32.4
HWS300P-36	36V	28.8 - 39.6	8.4	302.4	14 / 28	504 / 1008	14.3 / 28.6	41.4 - 48.6
HWS600P-36	36V	28.8 - 39.6	16.7	601.2	27 / 55.5	972 / 1998	27.5 / 56.6	41.4 - 48.6
HWS300P-48	48V	38.4 - 52.8	6.3	302.4	10.5 / 21	504 / 1008	10.7 / 21.4	55.2 - 64.8
HWS600P-48	48V	38.4 - 52.8	12.5	600	20 / 41.5	960 / 1992	20.4 / 42.3	55.2 - 64.8

Notes

- (1) 100/200VAC
- (2) 200-265VAC Input, 5s maximum on time up to 35% duty cycle (see instruction manual)

Outline Drawing HWS300P

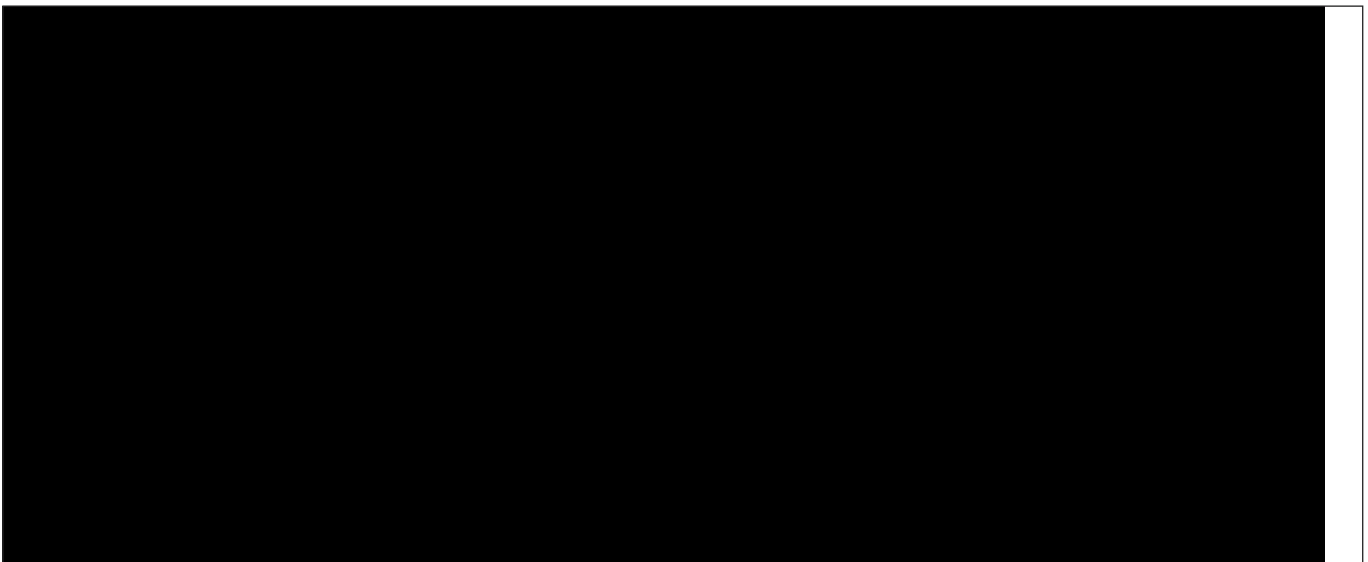

Outline Drawing HWS600P

SIGNAL CONNECTOR INFORMATION

== ACCESSORIES ==

- COVER FOR BARRIER TERMINAL STRIP (ATTACHED ON TERMINAL AT SHIPMENT)
- SHORT PIECE (SHORTING CNT - TOG) (ATTACHED ON CN1 AT SHIPMENT)

== SIGNAL CONNECTOR USED ==

PART DESCRIPTION	PART NAME	MANUFACT
PIN HEADER	SSB-PHDS	JST

== MATCHING HOUSINGS, PINS & TOOL ==

PART DESCRIPTION	PART NAME	MANUFACT
SOCKET HOUSING	PHDR-DBVS	JST
TERMINAL PINS	SPH0-002T-P0.5(AWG28-24) SPH0-001T-P0.5(AWG26-22)	JST
HAND CRIMPING TOOL	YRS-620(SPH0-002T-P0.5) YC-610R(SPH0-001T-P0.5)	JST

== NOTES ==

A : MODEL NAME, NOMINAL OUTPUT VOLTAGE AND MAXIMUM OUTPUT CURRENT ARE SHOWN IN THE NAME PLATE IN ACCORDANCE WITH THE SPECIFICATIONS.

B : M4 TAPPED HOLES (8) FOR CUSTOMER CHASSIS MOUNTING. (SCREW PENETRATION DEPTH 6mm MAX.)



HWS300P Peak Output Power vs. Duty Cycle

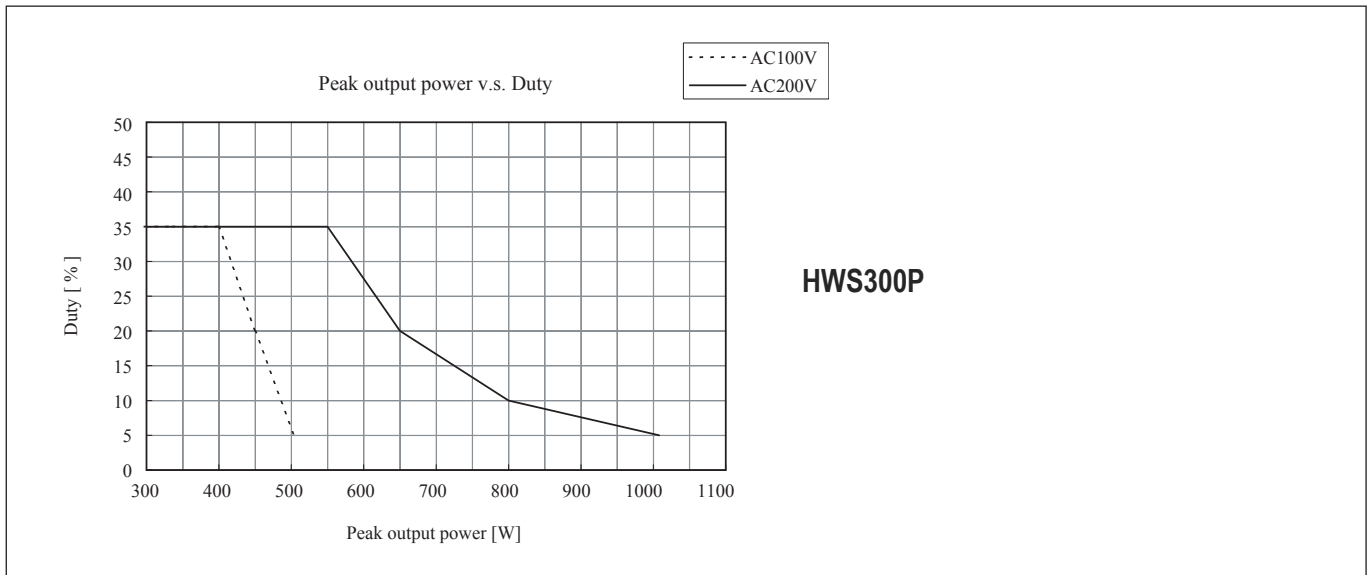

HWS600P Peak Output Power vs. Duty Cycle

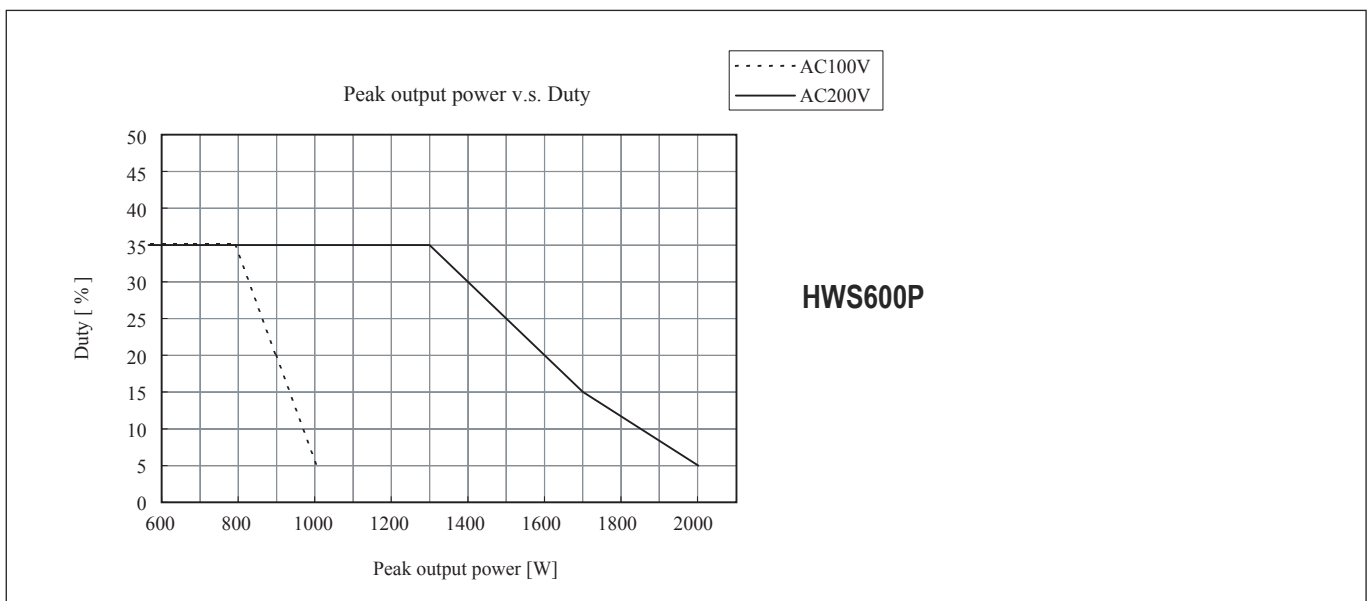

Options

Suffix	Description
Blank	HWS300-1500 cover is fitted as standard
/A	Not applicable

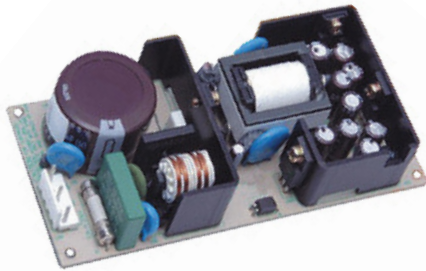

- 26mm height
- 3 year Warranty
- Peak Load capable
- Light weight
- Output 1 isolated from outputs 2 & 3

MTW Series

15W to 60W Low Profile Triple Output Power Supplies

Key Market Segments & Applications

- Factory Automation
- Test & Measurement
- Automated Service
- Portable Equipment

MTW Features and Benefits

Features

- Low Profile
- Three Year Warranty
- Output 1 is isolated from outputs 2 & 3

Benefits

- Assists System Integration
- Low Cost of Ownership
- Outputs V2 & V3 can be connected in series

Specifications

ITEMS		MODELS	MTW15-51212 MTW15-51515	MTW30-51212 MTW30-51515	MTW60-51212 MTW60-51515
Input Voltage Range		V	85 - 265VAC (47 - 440Hz)		
Input Current Typ	(1)	A	0.42 / 0.25	0.8 / 0.4	1.4 / 0.8
Inrush Current	(1)	A	25 / 50	20 / 40	20 / 40
Leakage Current (240VAC, 60Hz)		mA	0.75mA Max		
Max Output Power		W	16	30	60
			17.5	33	62.5
Efficiency (Typ)		%	71	76	76
Hold Up Time	(1)	ms	20 / 150	20 / 140	10 / 20
Output Voltage Adjustment		-	Fixed		
Overcurrent Protection		-	Yes, automatic recovery. Hiccup style on MTW30 & 60		
Overvoltage Protection		V	V1: Zener Clamp	V1: Zener Clamp	V1 & V2: Zener Clamp
Operating Temperature		-	-20°C start up. -10°C to +60°C, derating linearly to 70% load above 50°C		
Storage Temperature		-	-30°C to +75°C		
Humidity (Non condensing)		-	10 - 90%RH (Operating & storage) at 35°C		
Cooling		-	Convection		
Withstand Voltage		-	Input to ground 2kVAC, Input to output 3kVAC, Output to ground 500VAC		
Vibration (non operating)		-	5 - 10Hz: 10mm amplitude, 10 - 200Hz: 2G (19.6m/s ²)10m sweep time, 3 axis, 1 hour each		
Shock		-	Acceleration: 60G (588m/s ²) Half sine wave, 6 - 16ms pulse duration, 3x each direction		
Safety Agency Approvals		-	UL60950-1, CSA C22.2 No 60950-1 (C-UL), EN60950-1		
Immunity		-	EN61000-4-2 (Lv 4), -3, -4 (Lv 3), -5 (Lv 4), -6 (Lv 3), -8 (Lv 4), -11		
Conducted EMI		-	FCC-Class B, EN55011-B, EN55022-B		
Weight (Typ)		g	150	210	330
Size (WxHxL)		mm	50 x 26 x 127	65 x 26 x 140	83 x 26 x 185
Warranty		yrs	3		

Notes:

(1) 100/240VAC



Model Selector

Model	Output	Voltage (V)	Regulation	Minimum Current (A)	Maximum Current (A)	Peak Current (A)	Ripple & Noise (mV)
MTW15-51212	V1	5V	4.75 - 5.25V	0	2.0	3.0	120
	V2	12V	11.4 - 12.6V	0	0.3	0.6	150
	V3	-12V	11.4 - 12.6V	0	0.2	0.3	150
MTW15-51515	V1	5V	4.75 - 5.25V	0	2.0	3.0	120
	V2	15V	14.4 - 15.6V	0	0.3	0.6	150
	V3	-15V	14.4 - 15.6V	0	0.2	0.3	150
MTW30-51212	V1	5V	4.9 - 5.3V	0	3	4.5	120
	V2	12V	11.4 - 12.6V	0	1.2	2.0	150
	V3	-12V	11.4 - 12.6V	0	0.3	0.45	150
MTW30-51515	V1	5V	4.9 - 5.3V	0	3	4.5	120
	V2	15V	14.25 - 15.75V	0	0.8	2.0	150
	V3	-15V	14.25 - 15.75V	0	0.3	0.45	150
MTW60-51212	V1	5V	4.9 - 5.3V	0	5.0	7.0	120
	V2	12V	11.4 - 12.6V	0	2.5	3.5	150
	V3	-12V	11.4 - 12.6V	0	0.5	0.7	150
MTW60-1515	V1	5V	4.9 - 5.3V	0	5.0	7.0	120
	V2	15V	14.25 - 15.75V	0	2.0	3.5	150
	V3	-15V	14.25 - 15.75V	0	0.5	0.7	150

Mating Connectors

	Model	Input	Output
Connectors	MTW15	B3P5-VH-B	B8B-XH-2
JST	MTW30	B3P5-VH-B	B6P-VH-B
	MTW60	B3P5-VH-B	B8P-VH-B



Outline Drawing MTW15 Series

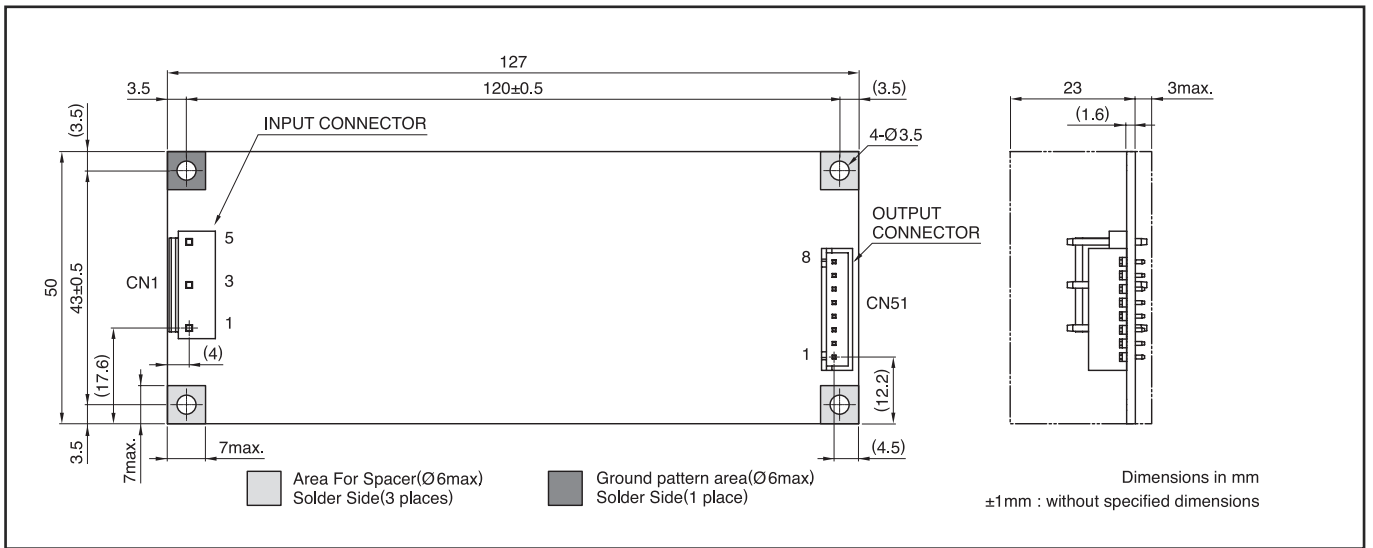

Outline Drawing MTW30 Series

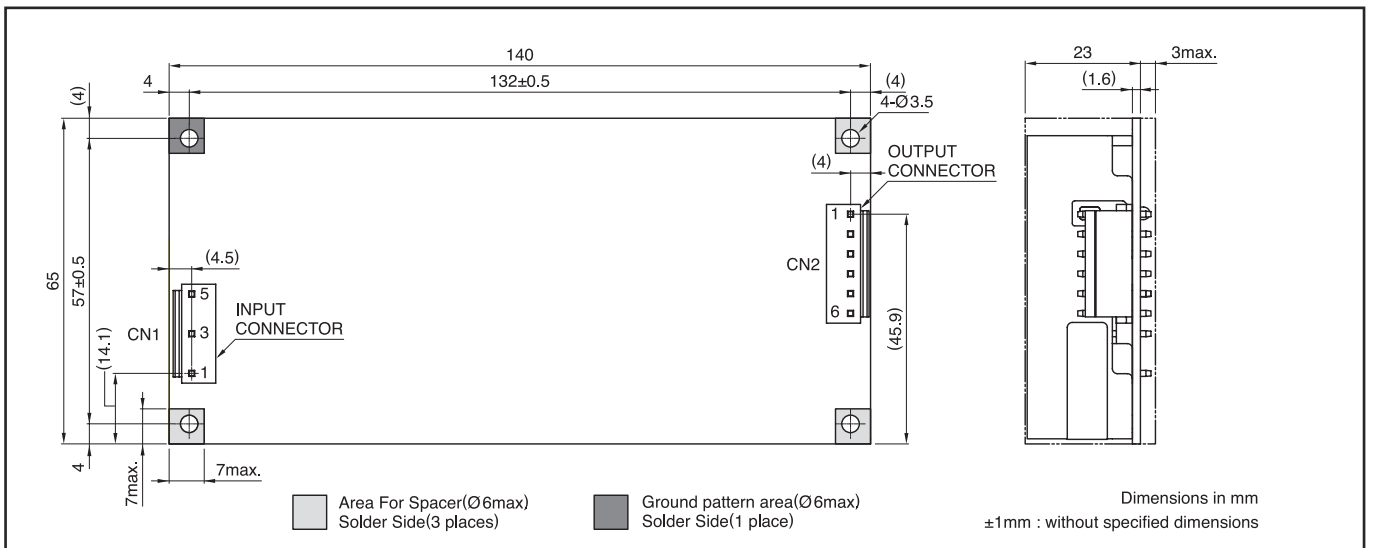



- 5 Year Warranty
- Ultra Thin Package
- SEMI F47 Compliant (high line AC)
- Universal Input (85 - 265VAC)
- High Efficiency

Key Market Segments & Applications

Semiconductor Fabrication
 Test & Measurement:
 LED Signs

RTW Series

Single Output Industrial Power Supplies

RTW Features and Benefits

Features

- 5 Year Warranty
- Ultra Thin Package
- Wide range AC Input

Benefits

- Lower Cost of Ownership
- Allows use in small spaces
- Supports global use

Specifications

MODELS		50W	100W	150W	300W
ITEMS					
Input Voltage range	(1)	85 - 265VAC (47 - 440Hz), 120-370VDC			
Input Current (100/200VAC) (Typ)	A	0.7 / 0.4	1.5 / 0.75	1.9 / 1.0	2.0 / 4.0
Inrush Current (100/200VAC)	A	14 / 28			15 / 30
Power Factor	-	Meets EN61000-3-2			
Overcurrent Protection	-	Yes, typically 105 - 125% (100 & 150W hiccup style)			
Overvoltage Protection	V	Yes, typically 120-140%. Cycle input to reset			
Hold Up Time (100/200VAC)	ms	>20			
Leakage Current (max at 240VAC)	mA	0.6	0.45	0.65	0.75
Load Regulation	%	0.4% (0-100% load change)			
Line Regulation	%	0.2% (85-132 or 170-265VAC line change)			
Remote Sense	-	Yes			
Current Share	-	No			Yes
Remote On/Off	-	Yes, see instruction manual on website			
DC Fail Signal	-	No			Yes
Indicator	-	Green LED = ON			
Operating Temperature	-	-10°C to +71°C, -20°C start up. See derating curves on sheet 2			
Storage Temperature	°C	-30°C to +75°C			
Humidity (non condensing)	-	10 - 95%RH			
Cooling	-	Convection			
Withstand Voltage	-	Input to Ground 2kVAC, Input to Output 3kVAC, Output to Ground 500VAC for 1 min.			
Isolation Resistance	-	>100MΩ at 25°C & 70%RH, Output to Ground 500VDC			
Vibration (non operating)	-	5 - 200Hz (10 min sweep), 19.6m/s ² , 1 hour (Amplitude 10mm)			
Shock (Vertical mounting)	-	392m/s ²	196m/s ²	588m/s ²	
Safety Agency Approvals	-	UL60950-1, CSA60950-1 (cUL), EN60950-1, CE Mark			
Line Dip	-	Complies with SEMI F47 (200VAC line only)			
Conducted & Radiated EMI	-	EN55011 / EN55022-B, FCC-B			
Immunity	-	IEC61000-4-2 (Level 4), -3, -4 (Level 3), -5 (Level 4)			
Weight (Typ)	g	290	450	600	1300
Size (WxHxD)	mm	22 x 82 x 124	25 x 82 x 160	30 x 92 x 180	40 x 120 x 250
Warranty	yrs	5			

Notes: (1) Safety approvals do not cover DC input



Model Selector

Model	Voltage (V)	Adjustment Range	Max Current (A)	Max Power (W)	Ripple/Noise (mV)	Efficiency (typ)% ²	Pack Size
RTW03-12R	3.3V	2.6 - 4.0	12.5	41.2	120	75 / 77	50W
RTW03-25R	3.3V	2.6 - 4.0	25	82.5	120	79 / 81	100W
RTW03-35R	3.3V	2.6 - 4.0	35	115.5	120	80 / 83	150W
RTW03-70RH	3.3V	1.8 - 3.6	70	231	120	83 / 86	300W
RTW05-10R	5V	4.0 - 5.8	10	50	120	80 / 82	50W
RTW05-20R	5V	4.0 - 5.8	20	100	120	83 / 85	100W
RTW05-30R	5V	4.0 - 5.8	30	150	120	83 / 86	150W
RTW05-60RH	5V	3.5 - 5.6	60	300	120	84 / 87	300W
RTW12-4R3	12V	9.6 - 13.2	4.3	51.6	150	81 / 83	50W
RTW12-8R4	12V	9.6 - 13.2	8.4	100.8	150	84 / 86	100W
RTW12-12R	12V	9.6 - 13.2	12.5	150	150	84 / 87	150W
RTW12-25RH	12V	7.2 - 14.4	25	300	150	83 / 86	300W
RTW15-3R5	15V	12.0 - 16.5	3.5	52.5	150	82 / 85	50W
RTW15-6R7	15V	12.0 - 16.5	6.7	100.5	150	85 / 87	100W
RTW15-10R	15V	12.0 - 16.5	10	150	150	84 / 87	150W
RTW15-20RH	15V	10.5 - 18.0	20	300	150	83 / 86	300W
RTW24-2R2	24V	19.2 - 26.4	2.2	52.8	200	82 / 85	50W
RTW24-4R2	24V	19.2 - 26.4	4.2	100.8	200	85 / 87	100W
RTW24-6R3	24V	19.2 - 26.4	6.3	151.2	150	86 / 88	150W
RTW24-13RH	24V	16.8 - 26.4	13	312	200	85 / 88	300W
RTW28-1R8	28V	22.4 - 30.8	1.8	50.4	200	82 / 85	50W
RTW28-3R6	28V	22.4 - 30.8	3.6	100.8	200	85 / 87	100W
RTW28-5R4	28V	22.4 - 30.8	5.4	151.2	200	86 / 88	150W
RTW28-11RH	28V	19.6 - 33.6	11	308	200	85 / 88	300W
RTW48-1R1	48V	38.4 - 52.8	1.1	52.8	300	82 / 85	50W
RTW48-2R1	48V	38.4 - 52.8	2.1	100.8	300	85 / 88	100W
RTW48-3R2	48V	38.4 - 52.8	3.2	153.6	200	86 / 89	150W
RTW48-6R5H	48V	33.6 - 55.0	6.5	312	300	86 / 89	300W

Notes: (2) 100/200VAC See website technical downloads for detailed information

Options

Suffix	Description
L	Vertical Terminal Block (option for 50W & 100W models only)
C	Cover (50W, 100W & 150W models)
H	Cover (300W models)



Derating Curves RTW50-150W Series

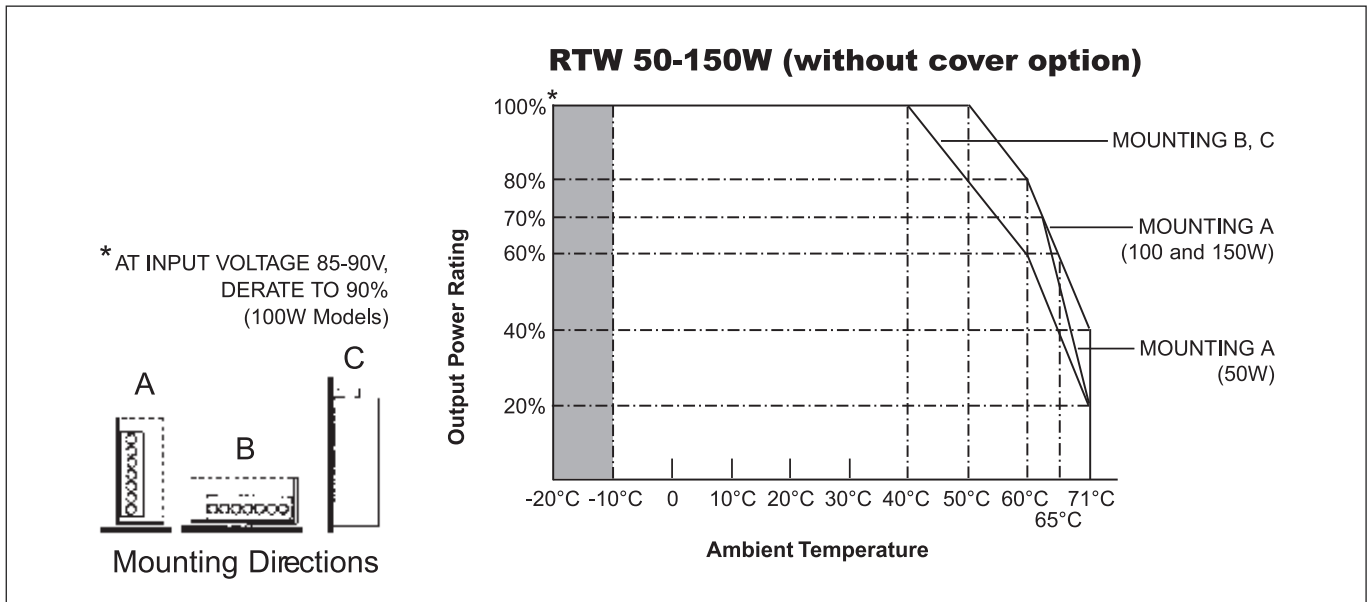

Derating Curve RTW 300W Series

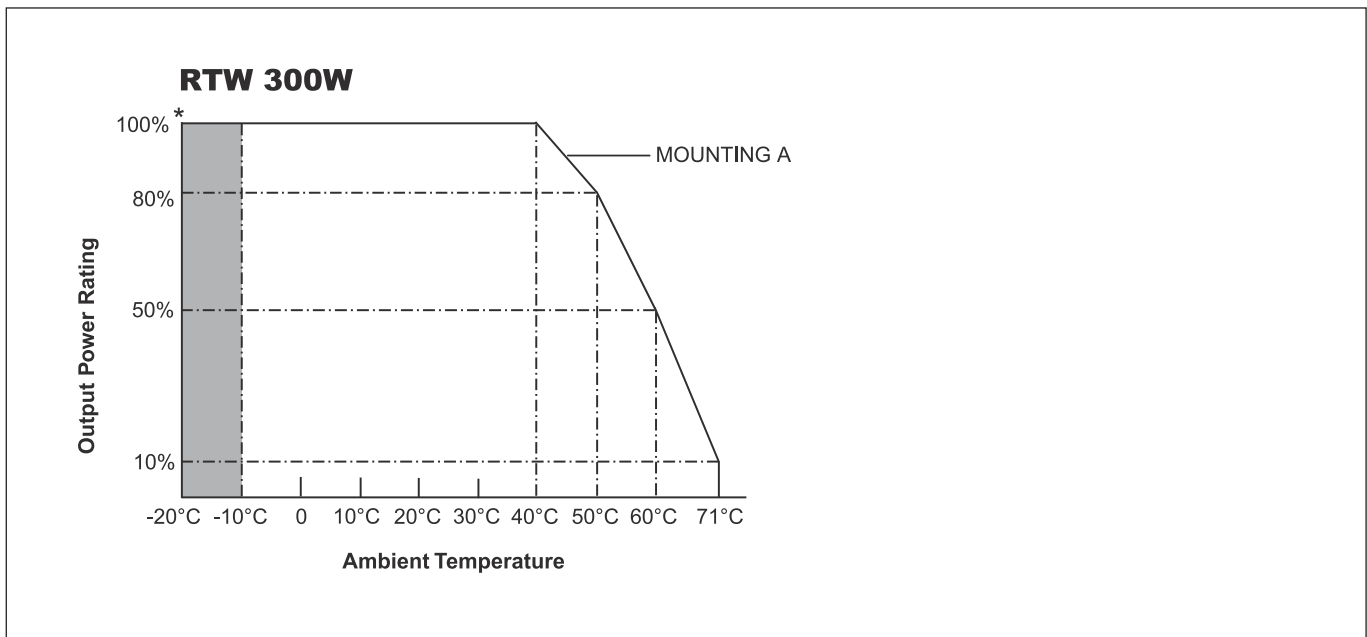



- Low Cost
- Active Power Factor Correction
- Input Transient Protected IEC61000-4
- Enclosed

Key Market Segments & Applications

Factory Automation	Process Control, NC-Machining, Automotive, Packaging Equipment, Materials Handling, Chemical Processing, Robots
Test & Measurement	Burn-in & Test, Automated, Detection Test, Instrumentation, Measurement
Automated Service	Vending Machines, Elevators, Video Gaming, Point of Sale Equipment

SWS300A&600 Series

Single Output
General Purpose Power Supplies

SWS300A&600 Features and Benefits

Features

- Meets IEC61000-4
- Global Safety Approvals
- Power Factor Corrected
- Level B EMI

Benefits

- Greater Reliability
- Supports Global Use
- Assists System Compliance

Specifications

ITEMS		MODEL	SWS300A	SWS600
Input Voltage range	(1)	-	85 - 265VAC (47 - 63Hz) or 120 - 370VDC	
Inrush Current (115 / 230VAC)		A	20 / 40	
Power Factor		-	Meets EN61000-3-2	
Input Current (100/200VAC)		A	3.6 / 1.8 (3.3V: 2.5/1.3, 4V:2.8/1.4, 5V: 3.2/1.6)	7.2 / 3.6 (3.3V: 4.3/2.2, 5V: 6.6/3.3)
Temperature Coefficient		-	<0.02%/°C	
Overcurrent Protection		-	>105%, Constant current style	
Overvoltage Protection		V	3.3V: 4.1-5.3V, 4V: 5.0-6.0V, 5V: 6.25-7.5V, 7.5V: 9.4-11.2V, 12V: 13.8-16.8V 15V: 19.3-24.2V, 24V: 30-34.8V, 28V: 35-40.6V, 36V: 41.4-50.4V, 48V: 60-69.6V	
Overtemperature Protection		-	Yes, cycle AC to reset	
Hold Up Time (Typ)		ms	20ms at 115/230VAC	
Leakage Current (max)		mA	0.75	1.5
Remote Sense		-	None	Yes
Parallel Connection		-	None	Yes
Remote On/Off		-	None	Yes
DC Good Signal		-	None	Yes, open collector output
LED Indicator		-	Green LED = On	
Operating Temperature		°C	-10°C to +65°C (See table for derating - model specific)	
Storage Temperature		°C	-30°C to +85°C	
Operating Humidity		%RH	30 - 90 (non condensing)	
Storage Humidity		%RH	10 - 95 (non condensing)	
Cooling		-	Internal fan	
Withstand Voltage		-	I/P to Gnd 2kVAC, I/P to O/P 3kVAC, O/P to Gnd 500VAC, (O/P to CNT 100VAC for 1 min SWS600)	
Isolation Resistance		-	>100MΩ at 25°C & 70%RH, Output to Ground 500VDC	
Vibration (non operating)		-	10 - 55Hz (sweep for 1 min)19.6m/s ² constant X, Y, Z 1 hour each plane)	
Immunity		-	EN61000-4-2, -3, -4, -5, -6, -8, -11	
Safety Agency Approvals		-	UL60950-1, CSA60950-1, EN60950-1, EN50178, CE Mark	
Conducted & Radiated EMI		-	EN55011 / EN55022-B, FCC Class B	
Weight (Typ)		g	950	2000
Size (WxHxD)		mm	52 x 102 x 198	92 x 120 x 190
Warranty		yrs	2	

Notes: (1) Derate linearly to 85% load from 115VAC to 85VAC input (derate to 90% load for SWS600-5)



Model Selector							
Model	Voltage	Adjust Range (V)	Max Current (A)	Load Reg mV	Line Reg mV	Ripple Noise mV	Eff. (3) (typ)%
SWS300A-3	3.3	2.97-3.96	55	40	20	120	69/72
SWS300A-4	4	3.6-4.8	55	40	20	120	72/75
SWS300A-5	5	4.6-6.0	55	40	20	120	75/78
SWS300A-7R5	7.5	6.0-9.0	40	60	30	120	77/80
SWS300A-12	12	9.6-13.2	26	96	48	120	79/83
SWS300A-15	15	13.2-18.6	21	120	48	120	80/84
SWS300A-24	24	20-28.8	13	120	48	150	82/85
SWS300A-28	28	22.4-33.6	11	140	56	150	83/86
SWS300A-36	36	28.8-40	8.8	180	72	200	83/87
SWS300A-48	48	40-57.6	6.7	240	96	240	83/86
SWS600-3	3.3	2.97-3.96	100 (2)	40	20	100	69/71
SWS600-5	5	4.5-6	100 (2)	40	20	100	74/77
SWS600-12	12	9.6-13.2	50	96	48	120	78/81
SWS600-15	15	13.2-18.6	40	120	48	120	80/83
SWS600-24	24	20-28.8	25	120	48	150	81/84
SWS600-36	36	28.8-40	16.7	180	72	200	81/85
SWS600-48	48	40-57.6	12.5	240	96	240	82/85

Notes: (2) Peak rating of 120A for 10s (3) 115/230VAC

Derating				
Model	50°C	55°C	60°C	65°C
SWS300A	100%	91.6%	83.3%	50%
SWS600	100%	85%	70%	55%

Additional derating required when operating SWS600 with side ventilation holes blocked
See installation manual.



Outline Drawing SWS300A Series

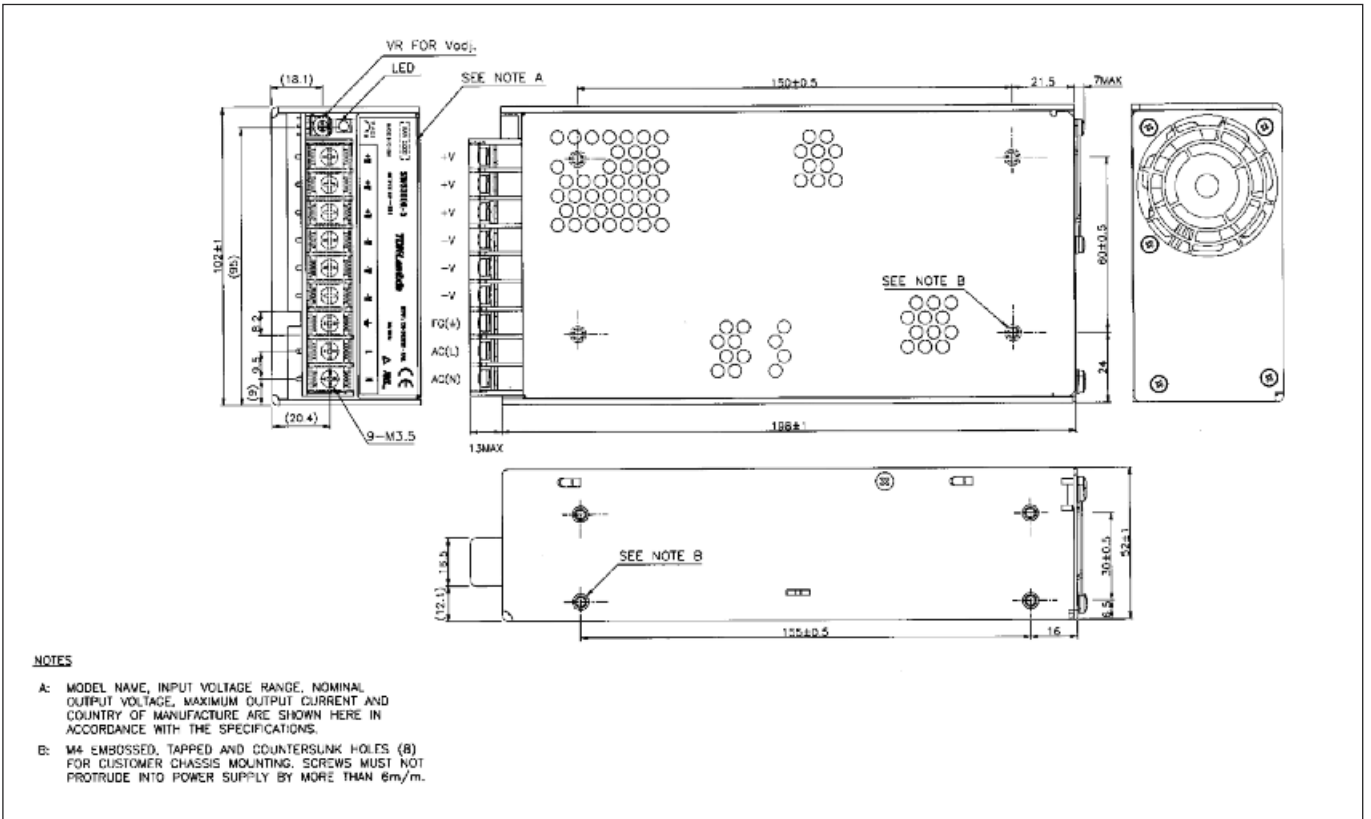

Outline Drawing SWS600 Series

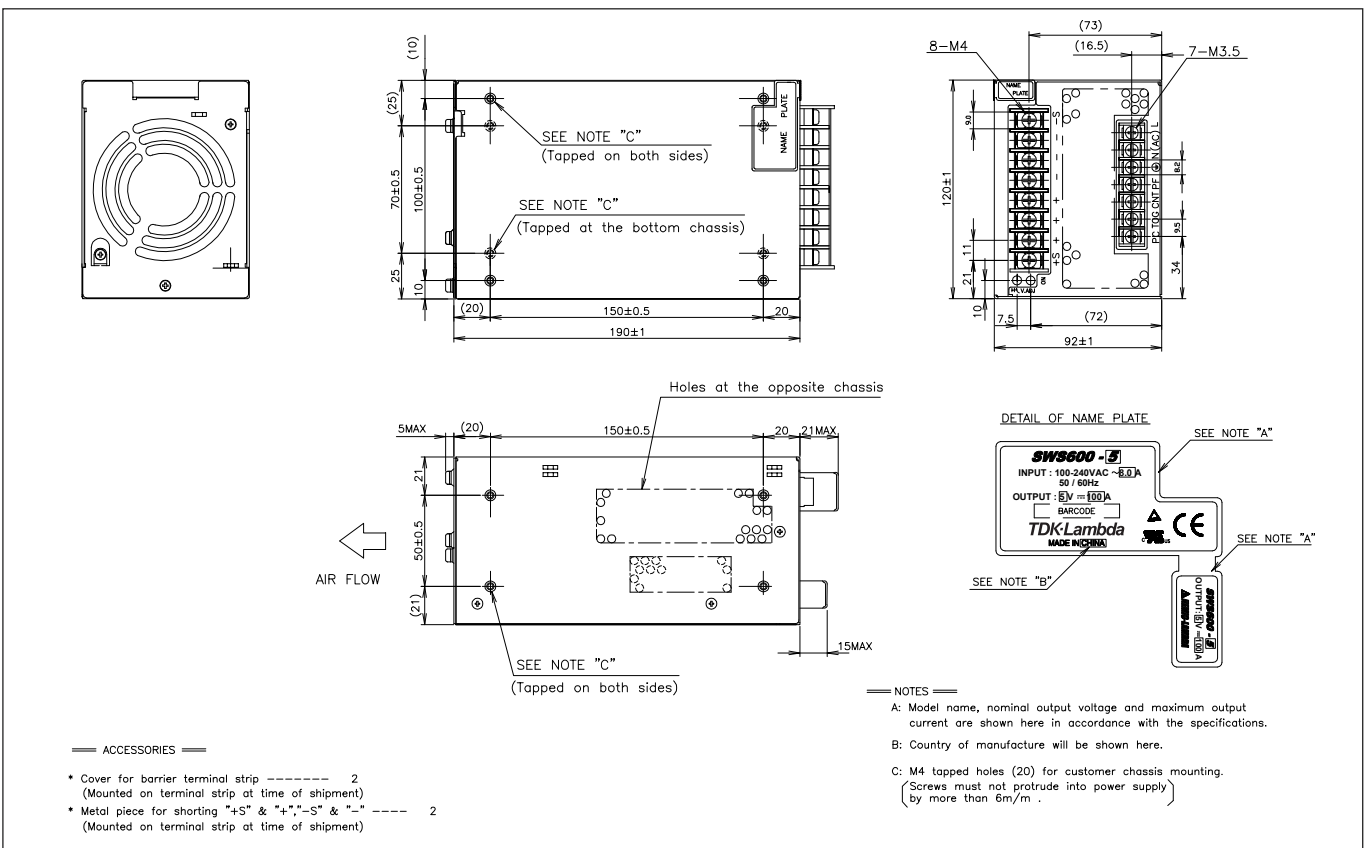



- Quiet Temperature Controlled Fan
- Low Cost
- Low Profile
- Wide Operating Temperature Range
- Active Power Factor Correction
- Medical Approvals (SWS1000L)

SWS600/1000L Series

600W and 1000W Low Profile Single Output Power Supplies

SWS600/1000L Features and Benefits

Features

- Temperature Controlled Fan
- Global safety Approvals
- Wide Temperature Range
- Level B EMI

Benefits

- Low Acoustic Noise
- Supports Global Use
- Suitable for Outdoor Temperature Extremes
- Assists System Compliance

Specifications

MODEL		SWS600L	SWS1000L
ITEMS			
Input Voltage range	-	85 - 265VAC (47 - 63Hz) or 120 - 350VDC	
Inrush Current (115 / 230VAC)	A	20 / 40	
Power Factor	-	Meets EN61000-3-2 Class A	
Input Current (100/200VAC)	A	7.1 / 3.6 (3.3V : 5/2.5)	12/6 (3.3V : 8/4)
Temperature Coefficient	-	<0.02%/°C	
Overcurrent Protection	-	>105%, Constant current style	
Overvoltage Protection	V	125% -145%	
Over temperature Protection	-	Yes, cycle AC or Remote On/Off to reset	
Hold Up Time (Typ)	ms	20ms at 115/230VAC	
Leakage Current (max)	mA	<0.75mA	<0.3mA
Remote Sense	-	Yes	
Parallel Connection	-	Yes	
Remote On/Off (CNT)	-	Yes	
Voltage Programming	-	Yes, 1-6V adjusts output from 20 - 120% of nominal	
DC Good & Fan Fail Signal	-	Yes, open collector output	
Auxiliary Output	-	12V 0.1A	
LED Indicator	-	Green LED = On	
Operating Temperature	-	-40°C start up. -20°C to 74°C, derating linearly to 50% load above 50°C	
Storage Temperature	-	-40°C to +85°C	
Humidity (non condensing)	-	20 - 90% RH operating, 10 - 95%RH non operating	
Cooling	-	Internal fan	
Withstand Voltage(One minute)	-	Input to Ground 2kVAC, Input to Output 3kVAC, Output to Ground 500VAC, Output to CNT 100VAC	Input to Ground 2kVAC, Input to Output 4kVAC, Output to Ground 500VAC, Output to CNT 120VAC
Isolation Resistance	-	>50MΩ at 25°C & 70%RH, Output to Ground 500VDC	
Vibration (non operating)	-	MIL-STD-810F 514.5 CAT. 4, 10	
Shock (in packaging)	-	MIL-STD-810F 516.5 Procedure 1, V1	
Immunity	-	EN61000-4-2, -3, -4, -5, -6, -8, -11	
Safety Agency Approvals	-	UL, CSA, EN60950-1, EN/UL60601-1 (1000W only), IEC61010-1 (600W only), EN50178, CE Mark	
Conducted & Radiated EMI	-	EN55011 / EN55022-B, FCC Class B	
Weight (Typ)	g	1600	2300
Size (WxHxD)	mm	61 x 120 x 190	61 x 150 x 240
Warranty	yrs	3	



Note: (Numbers in brackets indicate peak current and power available at 170 - 265VAC Input, 10s max, 35% duty cycle)

Model Selector								
Model	Voltage (V)	Adjust Range (via Trim Pot)	Max Curr. (A)	Max Pwr (W)	Load Reg (mV)	Line Reg (mV)	Ripple Noise (mV)	Eff. ⁽¹⁾ (typ)%
SWS600L-3	3.3V	2.64 - 3.96V	120	396	30	20	120	70 / 72
SWS1000L-3	3.3V	2.64 - 3.96V	200	660	30	20	120	74 / 76
SWS600L-5	5V	4 - 6V	120	600	30	20	120	75 / 77
SWS1000L-5	5V	4 - 6V	200	1000	30	20	120	79 / 81
SWS600L-12	12V	9.6 - 14.4V	53	636	72	48	150	79 / 82
SWS1000L-12	12V	9.6 - 14.4V	88	1056	72	48	150	82 / 84
SWS600L-15	15V	12 - 19.5V	43	645	90	60	150	79 / 82
SWS1000L-15	15V	12 - 19.5V	70	1050	90	60	150	82 / 84
SWS600L-24	24V	19.2 - 28.8V	27 (31)	648 (744)	144	96	150	81 / 84
SWS1000L-24	24V	19.2 - 28.8V	44 (51)	1056 (1224)	144	96	150	84 / 86
SWS600L-36	36V	28.8 - 43.2V	18	648	216	144	200	82 / 84
SWS1000L-36	36V	28.8 - 43.2V	29	1044	216	144	200	84 / 86
SWS600L-48	48V	38.4 - 56V	13 (15)	624 (720)	288	192	200	82 / 84
SWS1000L-48	48V	38.4 - 56V	22 (25)	1056 (1200)	288	192	200	84 / 86
SWS600L-60	60V	48 - 66V	10	600	360	240	200	82 / 84
SWS1000L-60	60V	48 - 66V	17	1020	360	240	200	84 / 86



Outline Drawing SWS600L Series

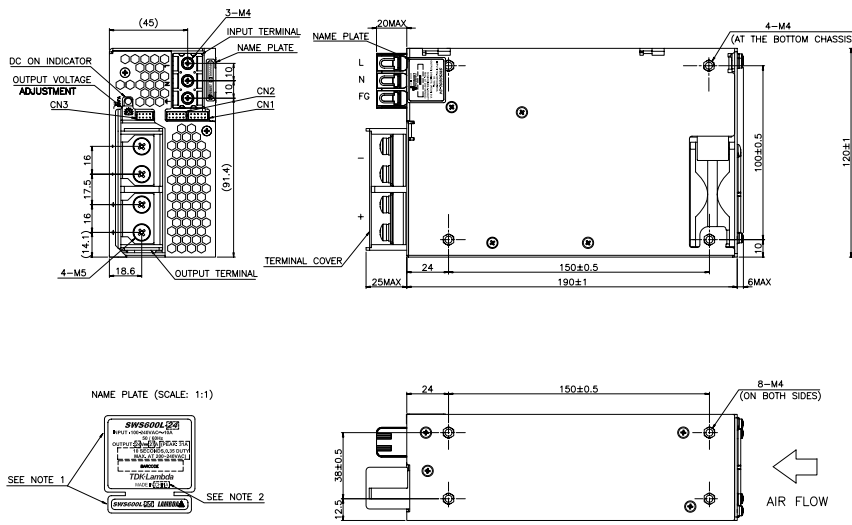

SIGNAL CONNECTOR INFORMATION

PIN CONFIGURATION AND FUNCTIONS OF CN1,CN2

PIN No.	FUNCTION
1	+V _m : +OUTPUT VOLTAGE MONITOR
2	+S : +SENSING
3	-V _m : -OUTPUT VOLTAGE MONITOR
4	-S : -SENSING
5	N.C. : NO CONNECTION
6	PC : CURRENT BALANCE
7	PV : ADJUSTMENT OF OUTPUT VOLTAGE
8	COM : GROUND FOR PC AND PV SIGNAL
9	CNT2 : REMOTE ON/OFF
10	TOG : REMOTE ON/OFF GROUND

PIN CONFIGURATION AND FUNCTIONS OF CN3

PIN No.	FUNCTION
1	COM : GROUND FOR PC AND PV SIGNAL
2	COM : GROUND FOR PC AND PV SIGNAL
3	AUX : AUXILIARY OUTPUT (12V 0.1A)
4	CNT1 : REMOTE ON/OFF
5	G2 : GROUND FOR AUX AND CNT1
6	G2 : GROUND FOR AUX AND CNT1
7	SLM : ALARM
8	G1 : ALARM GROUND

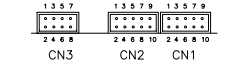

SIGNAL CONNECTOR USED

PART DESCRIPTION	PART NAME	MANUFACT
PIN HEADER	S10B-PH0SS (CN1,CN2) S8B-PH0SS (CN3)	JST

MATCHING HOUSINGS, PIN & TOOL

PART DESCRIPTION	PART NAME	MANUFACT
SOCKET HOUSING	PHDR-10VS (CN1,CN2) PHDR-8VS (CN3)	JST
TERMINAL PINS	SPHD-002T-P05(AWG28~24) SPHD-001T-P05(AWG26~24)	JST
HAND CRIMPING TOOL	YRS-620(SPHD-002T-P0.5) YC-610R(SPHD-001T-P0.5)	JST

NOTE:

- 1: MODEL NAME, INPUT VOLTAGE RANGE, NOMINAL OUTPUT VOLTAGE, NOMINAL OUTPUT CURRENT AND PEAK OUTPUT CURRENT ARE SHOWN ON THE NAME PLATE IN ACCORDANCE WITH THE SPECIFICATIONS
- 2: COUNTRY OF MANUFACTURE IS SHOWN ON THE NAME PLATE IN ACCORDANCE WITH THE SPECIFICATIONS
- 3: M4 TAPPED HOLES (12) FOR CUSTOMER CHASSIS MOUNTING (SCREW PENETRATION DEPTH 6m/m MAX.)
- 4: RECOMMENDED SCREW TORQUE OUTPUT TERMINAL(M5 SCREW) = 2.5N·m
INPUT TERMINAL(M4 SCREW) = 1.27N·m

Outline Drawing SWS1000L Series

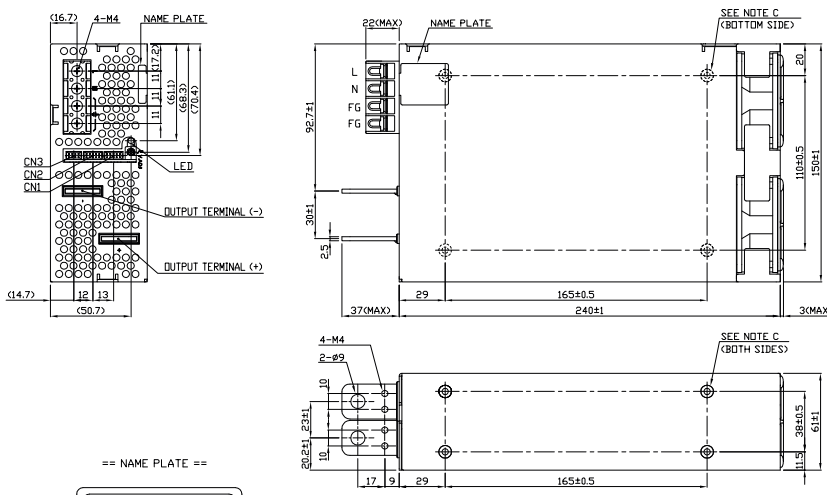

SIGNAL CONNECTOR INFORMATION

CN1,CN2 PIN ASSIGNMENT

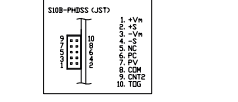

CN3 PIN ASSIGNMENT

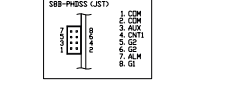

SIGNAL CONNECTOR USED

PART DESCRIPTION	PART NAME	MANUFACT
PIN HEADER (CN1 & CN2)	S10B-PH0SS	JST
PIN HEADER (CN3)	S8B-PH0SS	JST

MATCHING HOUSINGS, PINS & TOOL

PART DESCRIPTION	PART NAME	MANUFACT
SOCKET HOUSING (CN1 & CN2)	PHDR-10VS	JST
SOCKET HOUSING (CN3)	PHDR-8VS	JST
TERMINAL PINS	SPHD-002T-P0.5(AWG28~24) SPHD-001T-P0.5(AWG26~22)	JST
HAND CRIMPING TOOL	YRS-620(SPHD-002T-P0.5) YC-610R(SPHD-001T-P0.5)	JST

NAME PLATE

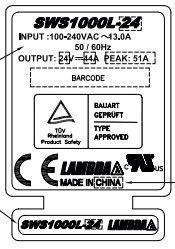

- == NOTES ==
- A: MODEL NAME, INPUT VOLTAGE RANGE, NOMINAL OUTPUT VOLTAGE, NOMINAL OUTPUT CURRENT AND PEAK OUTPUT CURRENT ARE ON NAME PLATE IN ACCORDANCE WITH THE SPECIFICATIONS.
 - B: COUNTRY OF MANUFACTURE IS SHOWN HERE.
 - C: M4 TAPPED HOLES (12) FOR CUSTOMER CHASSIS MOUNTING. (SCREW PENETRATION DEPTH 6m/m MAX.)



- 1U high
- Optional Internal ORing Diodes
- Current Share

RFE Series

1000W 1U Front End Power Supplies

RFE Features and Benefits

Features	Benefits
1U high	Utilizes less system space
Internal ORing diode option	Suitable for N+1 redundancy
Current Share	Can be paralleled for higher power
Full array of signals	Easier system monitoring

Specifications		RFE1000-24	RFE1000-32	RFE1000-48
ITEMS	MODEL			
Nominal Output Voltage	V	24V	32V	48V
Output Voltage Range (front panel)	V	21.5 - 29V	28.8 - 38.4V	43 - 58V
Output Current	A	40A	31A	21A
Output Power	W	960W	992W	1008W
Line Regulation	mV	96mV	128mV	192mV
Load Regulation	mV	192mV	256mV	384mV
Output Noise	mV	200mV	250mV	300mV
Overvoltage Protection (Latching)	V	31 to 34V	41.5 to 45.5V	62 to 66V
Overcurrent Protection	%	105 - 125%, Non foldback type		
Overtemperature	-	Yes, automatic reset		
Series Operation	-	Up to 3 units may be connected in series		
Current share	-	Single wire current sharing, up to 8 units		
Remote Sense	-	Compensates for up to 1V on each load wire		
Signals (opto isolated)	-	DC OK, AC Fail, and Overtemperature warning, high on fail		
Remote On/Off	-	On: 0 - 0.6V or short, Off: 2- 15V or open		
Auxiliary Output	-	12V 0.25A bias voltage, (11.2 to 12.5V). Built in ORing diode		
AC Input Range	-	85 - 265VAC, 47 - 63Hz		
AC Input Current (100/200VAC)	A	12 / 6A		
Leakage Current	mA	<1.1mA at 230VAC input		
Inrush Current	A	<40A		
Hold up time (100VAC input)	ms	20ms typical		
Efficiency (typical) 100/200VAC	%	86 / 88%	86 / 88%	87 / 89%
Power factor Correction	-	EN61000-3-2 class A (20-100% load), >0.98 at full load		
Immunity	-	EN61000-4-2, -3, -4, -5, -6, -11		
EMC (conducted and radiated)	-	EN55022, level B, FCC part 15J-B		
Operating Temperature	-	0°C to +70°C, derate 2%/°C from 50°C to 60°C, 2.5%/°C from 60°C to 70°C		
Storage Temperature	°C	-30°C to +85°C		
Withstand Voltage	-	Input to Output 3kVAC, Input to Output 2kVAC, Output to Ground 500VAC for 1 min.		
Isolation Resistance	-	>100MΩ at 25°C & 70%RH, Output to Ground 500VDC		
Cooling	-	Two variable speed internal fans, airflow exits across input/output		
Humidity	-	Operating: 10 - 90% RH, Storage: 10 - 95% RH (non condensing)		
Shock & Vibration	-	Meets ETS 300 019		
Safety Agency	-	UL60950-1, EN60950-1, CE Mark		
Input / Output Connector	-	Input: Screw terminals, Output: M5x12 screws, Signals: Mating connector JST PHDR-12VS		
Output indicator	-	Green LED DC OK		
Size (L x W x H)	mm	305 x 127 x 41		
Weight	g	2000		
Warranty	yrs	2		



Outline Drawing RFE Series

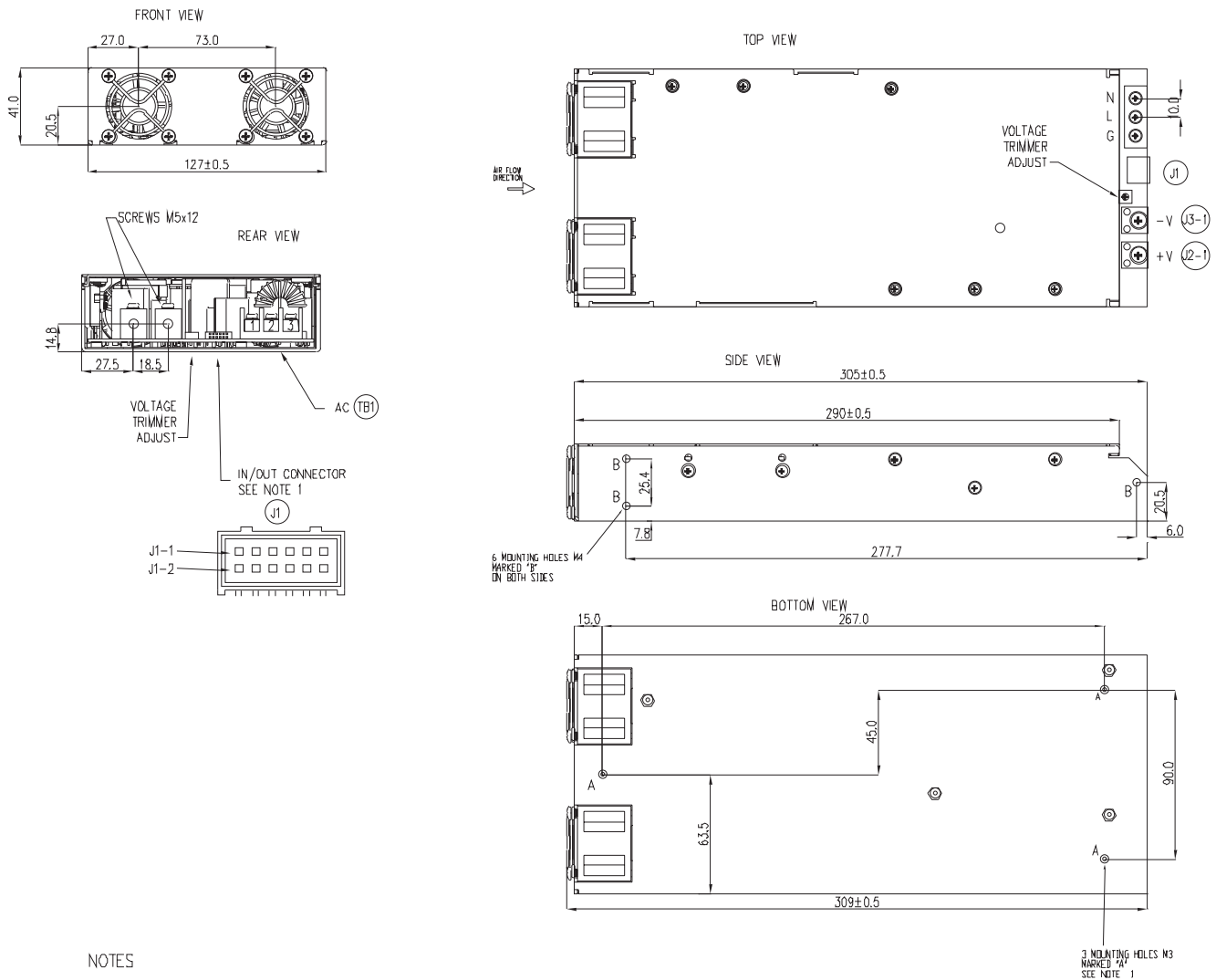

NOTES

- CONNECTOR TYPE: SI2B-PHDSS (JST)
FEMALE CONNECTOR TYPE: PHDR-12VS (JST)
- LED INDICATORS REFER TO INSTRUCTION MANUAL.
- MOUNTING SCREWS MUST NOT PENETRATE MORE THAN 3mm INTO THE UNIT.
- MODEL NAME, INPUT AND OUTPUT RATING AND SAFETY APPROVALS SYMBOLS ARE DESCRIBED ON TOP SURFACE LABEL.
- ALLOW MINIMUM 50 mm OF UNRESTRICTED AIR SPACE AT THE REAR OF UNIT. DO NOT OBSTRUCT AIR FLOW TO THE UNIT FRONT PANEL.
- IN OUT CONNECTOR BACK VIEW AND PINS ASSIGNMENT:

Options	
Suffix	Description
-Y	O Ring output diode

PIN.No.	FUNCTION
J1-3	+V
J1-10	-V
J1-6	ON/OFF
J1-1	+SENSE
J1-7	CURRENT SHARE
J1-9	CURRENT SHARE

PIN.No.	FUNCTION
J1-5	DC_OK
J1-11	SIGNAL_RTN
J1-12	AC_FAIL
J1-8	TEMP_ALARM
J1-2	-SENSE
J1-4	+12V AUX

PIN.No.	FUNCTION
TB1-1	AC GROUND
TB1-2	AC LINE
TB1-3	AC NEUTRAL



- Universal Input
- Baseplate cooled
- No fan required
- High Efficiency
- Protective coating
- No minimum load
- 2 Year Warranty

CPFE500F

500 Watts, single output, AC-DC, Conduction/Baseplate cooled power supply

Key Market Segments & Applications

- Outdoor Electronics
- LED Signage
- COTS
- Rugged environments
- Quiet/Silent Applications

Features and Benefits

Features

- Fanless
- Baseplate cooled
- Wide range ac input
- Diode ORing + share option

Benefits

- Longer field life and no fan noise
- Conducts heat outside of the system
- Supports global use
- Increases system reliability

INPUT			
Input Voltage	90 - 265Vac	Input Frequency	47 - 63Hz (440Hz with reduced PFC - consult factory)
Input Harmonics	EN61000-3-2 compliant	Power Factor	0.95 typical
Input Fuse	Fast acting (not user accessible)	Inrush Current	<40A at 25°C and 230Vac, (cold start) (meets EN61000-3-3)
Earth Leakage Current	1.5mA at 230Vac (50Hz)		

QUICK SELECTOR (Standard models). Additional variants available - contact sales office

Output Voltage	Max Output current	ORing diode?	Units with cover	
			Description	Order Code
12V	42A	Yes	CPFE500F-12-DL-C	T800097
		No	CPFE500F-12-NL-C	T800100
24V	18A	Yes	CPFE500F-24-DL-C	T800111
		No	CPFE500F-24-NL-C	T800122
28V	18A	Yes	CPFE500F-28-DL-C	T800133
		No	CPFE500F-28-NL-C	T800144
48V	10.5A	Yes	CPFE500F-48-DL-C	T800155
		No	CPFE500F-48-NL-C	T800166

HOW TO CREATE A PRODUCT CODE

Output	Adjustment Range	Maximum Current
12	9.6 - 14.4V	42A
24	22.4 - 33.6V	18A
28	22.4 - 33.6V	18A
48	38.4 - 57.6V	10.5A

ORing diode Option	
N	No ORing diode
D	ORing diode included Note:- Reduces maximum output Voltage by 1V

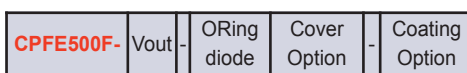

Coating Option	
C	Protective coating applied

Cover Option	
L	supplied with cover fitted

Confirm availability of created product code with the factory



ISOLATION				
Input to Output	Reinforced	4.24kV (dc)		
Input to Earth	Basic	2.12 kV (dc)	Output to Earth	500 Vdc

OUTPUT SPECIFICATION		
Output Power	504W	Continuous. Do not exceed maximum output current in 'How to Create a Product Code'.
Total Regulation	better than 4%	Including Line (for 90-264Vac input change), Load (for 0-100% load change) and temperature (0-50°C). The ORing diode option adds 1V to the load regulation specification.
Ripple & Noise	1%	pk-pk, using EIAJ test method & 20MHz bandwidth (1.5% below -10°C)
Voltage Setting Accuracy	±2%	at 50% load
Turn on time	1.5s	at 90Vac and 100% of rated output power.
Efficiency	85%	typical (at 75% load, without ORing diode).
Hold up	10ms	typical at 230 Vac, 100% load
Min Load	None	
Transient Response	<10%	of set voltage for 50% load change (in 50µs within the range 25 - 100% load)
Recovery	<0.5ms	for recovery to 2% of set voltage
Short circuit protection	Yes	Auto recovery after removal of short circuit
Over Temperature protection	Yes	Latching, need to cycle ac to restart unit.
Over Voltage Protection	Yes	Latching, need to cycle ac to restart unit.
Series Operation	Yes	
Parallel Operation	Yes	Single wire, up to 6 units
Remote Sense	Yes	Compensates for up to 500mV cable drop.

GLOBAL SIGNALS	
Remote on/off	Opto isolated, 2.5mA (10-14V) to enable power supply, less than 0.15mA (0.5V) to disable.
Standby Supply	12V+/-2V / 20mA isolated supply, not affected by remote on/off.
Output good (ENA)	Open collector (10mA sink current). Low (on) when output is in regulation
ORing diode	(option) - Allows redundant connection of power supplies with no additional diodes required.

ENVIRONMENT	
Baseplate Temperature	-40°C to 85°C operational (12V version 80°C max), -40°C to 85°C storage (max 12 months).
Low Temp Startup	-40°C
Humidity	20 - 90% RH non condensing
Shock	±3 x 30g shocks in each plane, total 18 shocks 30g shock = 11ms (+/-0.5msec), half sine Conforms to EN60068-2-27, EN60068-2-47, IEC68-2-27, IEC68-2-47, JIS C0041-1987. Conforms to MIL-STD-810E/F, Method 516.5, Pro I, IV, VI
Vibration	Single axis 10 - 500 Hz at 2g (sweep and endurance at resonance) in all 3 planes Conforms to EN60068-2-6, IEC68-2-6 Conforms to MIL-STD-810E, Method 514.4, Pro I, Cat 1,9
Altitude	-200 to 2000 metres operational (-200 to 5000m storage/transportation)
Weights	With lid = 1.4kg, no lid = 1.2kg
Pollution	Degree 2, Material group IIIb

IMMUNITY EN61000-6-2:2005				Criteria
Electrostatic Discharge	EN61000-4-2	Level 2	Air discharge level 3 Contact discharge level 2 Not applicable to units without lid	A
Electromagnetic Field	EN61000-4-3	Level 3	12V/m	A
Fast / Burst Transient	EN61000-4-4	Level 3		A
Surge Immunity	EN61000-4-5	Level 4	Common mode - 4.4kVac Differential - 2.2kVac	A
Conducted RF Immunity	EN61000-4-6	Level 3	12V	A
Power Frequency Magnetic Field	EN61000-4-8	Level 4	30A/m	A
Voltage Dips, Variations, Interruptions	EN61000-4-11	Class 3	as required by EN61000-6-2:2005	A/B
Ring Wave	EN61000-4-12	Level 3	Common mode - 2.2kV Differential - 1.1kV	A
Voltage Fluctuations	EN61000-4-14	Class 3		A



EMISSIONS EN61000-6-3:2007

Radiated Electric Field	EN55011, EN55022	(as per CISPR.11/22) Class B, FCC47 part 15 subpart B see application note for details
Conducted Emissions	EN55011, EN55022	(as per CISPR.11/22) Class B, FCC47 part 15 subpart B
	MIL STD 461E/462D CE102	115V and 220V
Conducted Harmonics	EN61000-3-2	Class A, Class C at full load.
Flicker	EN61000-3-3	Compliant - $d_{max} < 4\%$ only

SAFETY APPROVALS

	Edition / Date	Amendments		Edition / Date	Amendments
EN 60950-1	Edition 2 - 2006		IEC 60950-1*	Edition 2 - 2005	
UL 60950-1	Edition 2 - 2007		CSA 22.2 No 60950-1	Edition 2 - 2007	
CE Mark	LV Directive 2006/95/EC (EN60950-1)				
* CB certificate and Report available on request			Check with factory for status of approvals		

OUTLINE & CONNECTION DRAWINGS

CPFE500F

Signals Connections
Housing - Molex 22-01-1102
Crimp - Molex 50802 series
(or equivalents)

Pin	Function
10	Do not connect
9	Output good - ENA
8	Trim
7	Current share
6	Aux
5	+remote on/off
4	-remote on/off
3	Aux common
2	- Sense
1	+ Sense

264.00

10 1 126.00

dc output
M6 x 18 stud for +ve output
M6 x 18 stud for -ve output
M6 nut, spring washer and flat washer supplied for each terminal

ac input connector
Housing Tyco 350766-4
Crimp 926895-1 (3 off)
or equivalent

Live Earth Neutral

Notes 1. All customer fixings 10 x M4 clearance holes 2. All tolerances +/-0.5mm



- Universal Input
- Baseplate cooled
- No fan required
- High Efficiency
- Protective coating option
- No minimum load
- I²C interface
- 2 Year Warranty

CPFE1000F

1000 Watts, single output, AC-DC,
Conduction/Baseplate cooled power supply

Key Market Segments & Applications

- Outdoor Electronics
- LED Signage
- COTS
- Rugged environments
- Quiet/Silent Applications

Features and Benefits

Features

- Fanless
- Baseplate cooled
- Wide range ac input
- I²C interface

Benefits

- Longer field life and no fan noise
- Conducts heat outside of the system
- Supports global use
- Allows remote monitoring

INPUT

Input Voltage	90 - 265Vac	Input Frequency	47 - 63Hz (reduced PFC 63 - 440Hz - consult sales office)
Input Harmonics	EN61000-3-2 compliant	Power Factor	0.95 typical (meets EN61000-3-2)
Input Fuse	Fast acting (not user accessible)	Inrush Current	<40A at 25°C and 230Vac, (cold start) (meets EN61000-3-3)
Earth Leakage Current	1.3mA at 230Vac (50Hz)		

QUICK SELECTOR (Standard models)

Output Voltage	Adjustment Range	Output current	Description	Order Code
12V	9.6 - 14.4V	60A	CPFE1000F-12	XXXXXXX
28V	22.4 - 33.6V	36A	CPFE1000F-28	XXXXXXX
48V	38.4 - 57.6V	21A	CPFE1000F-48	XXXXXXX

GLOBAL SIGNALS

Remote on/off	Opto isolated, 2.5mA to enable power supply, less than 0.15mA to disable
Standby Supply	12V+/-2V / 20mA isolated supply, not affected by remote on/off.
Output good (ENA)	Open collector (10mA sink current). Low (on) when output is in regulation
I ² C	Provides manufacturing location, date, serial number, part number, unit revision, output voltage & current read back, base plate temperature, remote on/off, IOG, DC good and over temperature warning



ISOLATION				
Input to Output	Reinforced	4.24kV (dc)		
Input to Earth	Basic	2.12 kV (dc)	Output to Earth	500 Vdc

OUTPUT SPECIFICATION		
Output Power	1008W	Continuous. (12V versions = 720W)
Total Regulation	better than 4%	Including Line (for 90-264Vac input change), Load (for 0-100% load change) and temperature (0-50°C). The ORing diode option adds 1V to the load regulation specification.
Ripple & Noise	1%	pk-pk, using EIAJ test method & 20MHz bandwidth (2% below 0°C)
Voltage Setting Accuracy	±2%	at 50% load
Turn on time	1.5s	at 90Vac and 100% of rated output power.
Efficiency	85%	typical (at 75% load, without ORing diode).
Hold up	25ms	typical at 230 Vac, 100% load
Min Load	None	
Transient Response	<10%	of set voltage for 50% load change (in 50µs within the range 25 - 100% load)
Recovery	<0.5ms	for recovery to 2% of set voltage
Short circuit protection	Yes	Auto recovery after removal of short circuit
Over Temperature protection	Yes	Auto recovery
Over Voltage Protection	Yes	Auto recovery
Remote Sense	Yes	Compensates for up to 500mV cable drop

ENVIRONMENT								
Baseplate Temperature	-40°C to 85°C operational, -40°C to 100°C storage (max 12 months). (PFE1000F-28 and PFE1000F-48, -40°C to 70°C below 170Vac input)	Ambient Temperature Operating Limits						
Ambient Temperature	See adjacent table of operating limits		Output Power				Derating Factor	
Low Temp Startup	-40°C	Model No	Input Voltage	at 50°C	at 60°C	at 70°C		at 85°C
Humidity	20 - 90% RH non condensing, (non operating 10-95% RH) (PCB assembly protective coated)	CPFE1000F-12	85-170Vac	720W	720W	576W	360W	14.4W/°C
			170-265Vac	720W	720W	670W	595W	5W/°C
Shock	Conforms to MIL-STD-810E, Method 516.4, Pro I, II, IV, VI	CPFE1000F-28	85-170Vac	1008W	864W	720W		14.4W/°C
			170-265Vac	1008W	1008W	958W	883W	5W/°C
Vibration (non operating)	Conforms to MIL-STD-810E, Method 514.4, Pro I, Cat 1,9	CPFE1000F-48	85-170Vac	1008W	864W	720W		14.4W/°C
			170-265Vac	1008W	1008W	958W	883W	5W/°C
Altitude	-200 to 2000 metres operational (-200 to 5000m storage/transportation)							
Pollution	Degree 2, Material group IIIb							

IMMUNITY EN61000-6-2:2005				Criteria
Electrostatic Discharge	EN61000-4-2	Level 2	Air discharge level 3 Contact discharge level 2 Not applicable to units without lid	A
Electromagnetic Field	EN61000-4-3	Level 3	12V/m	A
Fast / Burst Transient	EN61000-4-4	Level 3		A
Surge Immunity	EN61000-4-5	Level X (Better than level 4)	Common mode - 6kV Differential - 6kV	A
Conducted RF Immunity	EN61000-4-6	Level 3	12V	A
Power Frequency Magnetic Field	EN61000-4-8	Level 4	30A/m	A
Voltage Dips, Variations, Interruptions	EN61000-4-11	Class 3	as required by EN61000-6-2:2005	A/B
Ring Wave	EN61000-4-12	Level 3	Common mode - 2.2kV Differential - 1.1kV	A
Voltage Fluctuations	EN61000-4-14	Class 3		A



EMISSIONS EN61000-6-3:2007

Radiated Electric Field	EN55011, EN55022	Class B (see application note for details)
Conducted Emissions	EN55011, EN55022 MIL STD 461E/462D CE102	Class B
Conducted Harmonics	EN61000-3-2	TBC
Flicker	EN61000-3-3	Compliant - $d_{max} < 4\%$ only

SAFETY APPROVALS

	Edition / Date	Amendments	Edition / Date	Amendments
EN 60950-1	Edition 2 - 2006		UL 60950-1	Edition 2 - 2007
CE Mark	LV Directive 2006/95/EC (EN60950-1)			
<i>Check with factory for status of approvals</i>				

OUTLINE & CONNECTION DRAWINGS

ac input connector
Housing Tyco 350766-1
Crimp 3 off
926895-1 (24-18 awg)
926893-1 (*20-14 awg)
or equivalent

dc output
M6 x 18 stud for +ve output
M6 x 18 stud for -ve output
M6 nut, spring washer and flat washer supplied for each terminal
Maximum tightening torque 10Nm

I2C
Molex 22-01-2037
Pins: Molex 2759 series

Notes

- All customer fixings 10 x M4 clearance holes
- All tolerances +/-0.5mm



LZSA Series

Single Output Industrial Power Supplies

- 5 Year Warranty
- -40°C to +71°C Operation
- MIL-STD-810E Vibration / Shock
- Input transient protected
- UL508, SEMIF47, Factory Mutual (Class 1, Division 2)

Key Market Segments & Applications

- Factory Automation
- Process & Controls
- Harsh Environments

LZSA Features and Benefits

Features

- Rugged mechanical design
- Superior thermal design
- Wide range adjustment of output
- Input voltage transient protected

Benefits

- High reliability in harsh conditions
- Longer life even at 71°C operation
- Reduces need for custom outputs
- Reduced system filtering

Specifications

MODELS		LZSA500	LZSA1000	LZSA1500
ITEMS				
Input Voltage (47-440Hz)*	-	85 - 265V (1500W: See output rating below 100VAC) 100-400VDC		
Inrush Current (110 / 220VAC)	A	20 / 40A	40 / 80A	
Power Factor	-	EN61000-3-2 Class A		
Efficiency (typical)	%	84%		
Ripple & Noise (Max) Pk-Pk	-	75mV	75mV	24V: 75mV 48V: 150mV
Line Regulation	%	0.1%		
Load Regulation	%	0.1%		
Transient Response	-	±1% deviation, recovering to ±0.2% in <1.25ms (25% load change)		
Overcurrent Protection	-	110 - 130%		
Overvoltage Protection	V	User adjustable from front panel		
Thermal Protection	-	Internal thermostat. Recycle AC to reset		
Hold Up Time at 110VAC	ms	20ms Hold Up, 20ms Ride Through		
Remote Sense	-	Compensates for a total of 1V cable drop		
Remote Adjust	-	Using front panel potentiometer, Resistance (1k/V), or Voltage (1V/V)		
Remote On / Off	-	TTL compatible, active high		
Signals	-	Optocoupled transistor for AC Fail, DC Good, Inverter OK, 200kHz sync signal (ref-sense)		
Indicators	-	Green LED indicates output good, red LED indicates overvoltage or over temperature		
Parallel Connection	-	Single wire current share		
Operating Temperature	°C	-40°C to +71°C, derate linearly to 60% load from 60°C to 71°C (20 min warm up period needed for <-30°C)		
Storage Temperature	°C	-40°C to +85°C		
Temperature Coefficient	-	0.01%/°C		
Humidity (non condensing)	%RH	10 - 90		
Cooling	-	Internal fan		
Withstand Voltage	-	Input - Ground 2,121VDC, Input - Output 4,242VDC, Output - Ground 500VDC		
Vibration	-	MIL-STD-810E, Method 516.4 Proc. I, II, IV, VI		
Shock	-	MIL-STD-810E, Method 514.4, Category 1, 9		
Safety Agency Approvals	-	UL60950-1, UL508, EN60950-1, FM 3600, 3611, 3810, & CE Mark. SEMIF47(>100VAC)		
Leakage current	uA	<500uA at 265VAC, 60Hz		
Emissions	-	EN55022/EN55011 Class B, EN61000-3-3, MIL STD461/462D CE102		
Immunity	-	EN61000-4-2, -3, -4, -5, -6, -8, -11. IEEE C62.41 (6kV/30 Ohm, Criteria A)		
Altitude	m	3,000m operating, 12,000m non operating		
Weight	kg	2.95	3.7	
Size (WxHxD) (w/o bus bars)	mm	108 x 121 x 260	143 x 121 x 267	
Warranty	yrs	5		

Notes: (Consult Installation Manual for detailed specifications, test methods and application notes)

*Reduced power factor above 63Hz



Outline Drawing LZSA500

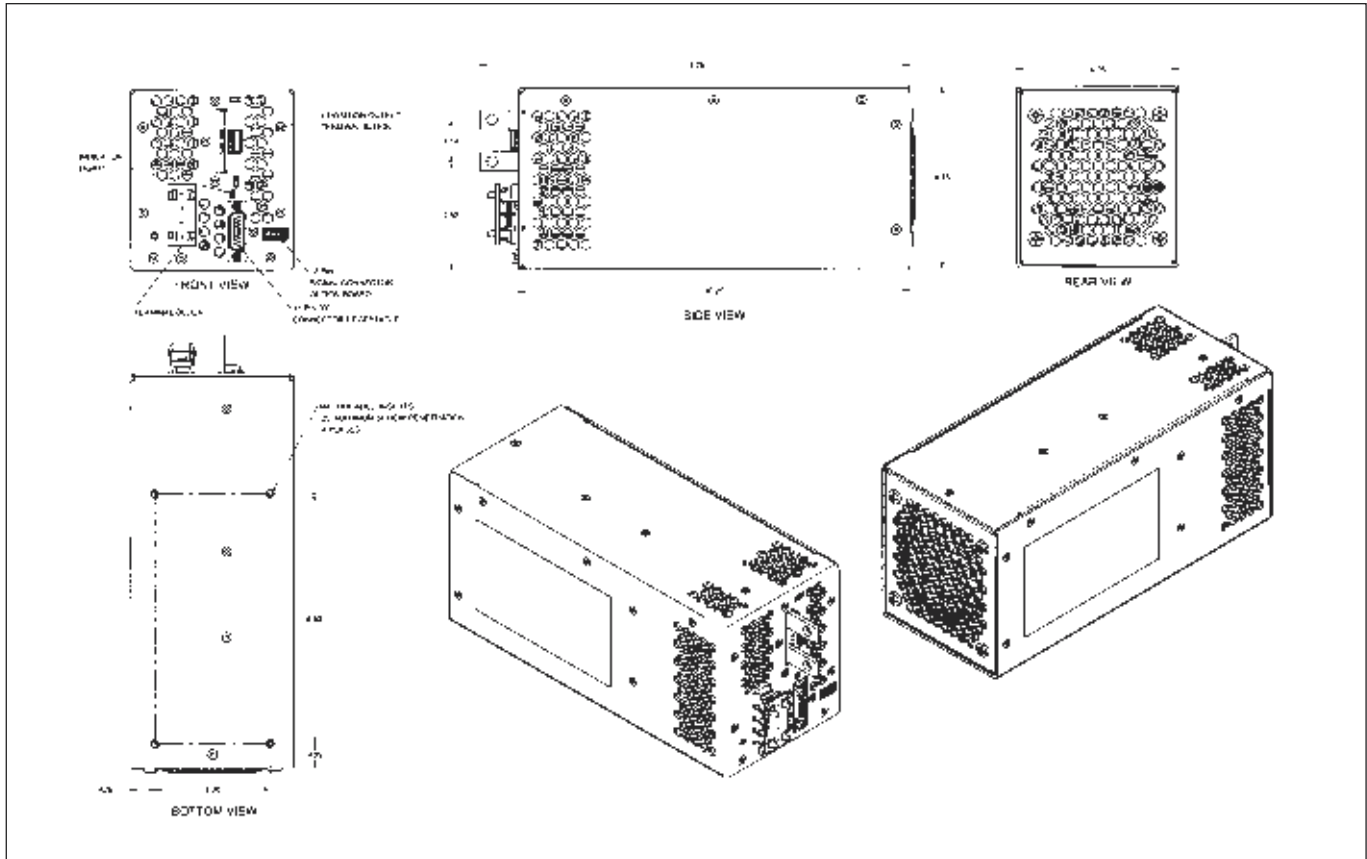

Outline Drawing LZSA1000/1500

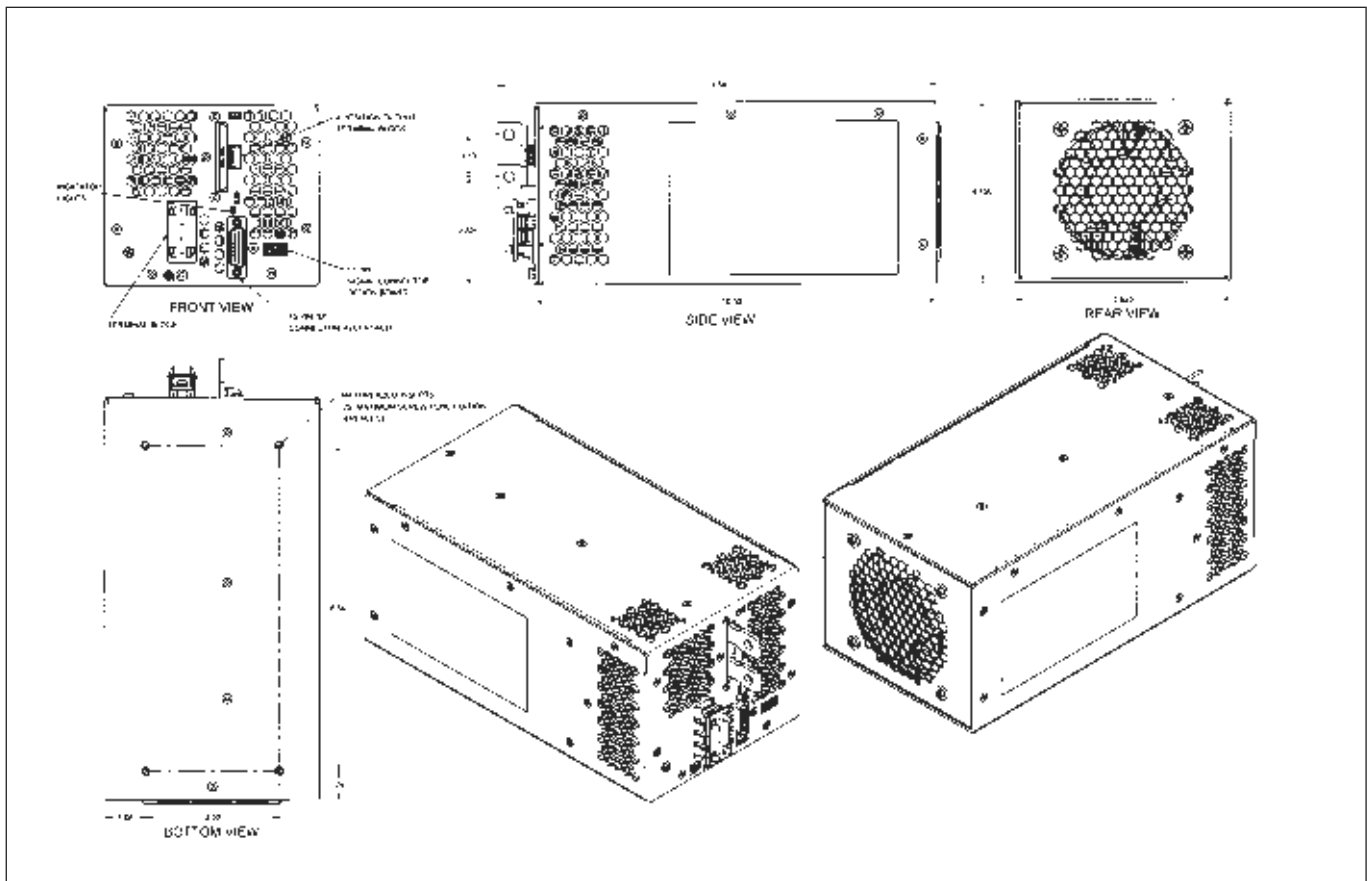



Connection Diagram LZSA500 Series

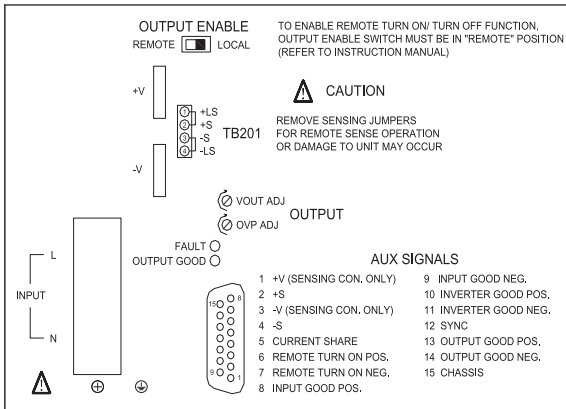

Model Selector

Model	Nominal Voltage (V)	Adjustment Range (V)	Maximum Current (A)	Maximum Power (W)
LZSA500-3	24	18 - 29.4	21	504
LZSA1000-2	12	10 - 15.75	84	1008
LZSA1000-3	24	18 - 29.4	42	1008
LZSA1500-3-001	24	18 - 29.4	63	1512 ⁽¹⁾
LZSA1500-4	48	36 - 56	31.5	1512 ⁽¹⁾

Note (1) 1512W @ 180-265VAC, 1200W @ 120VAC, 1104W @ 100 VAC, 1008W @ 85VAC

Figure 1 - PIN Assignments for TB201 and chassis mounted "D" connector

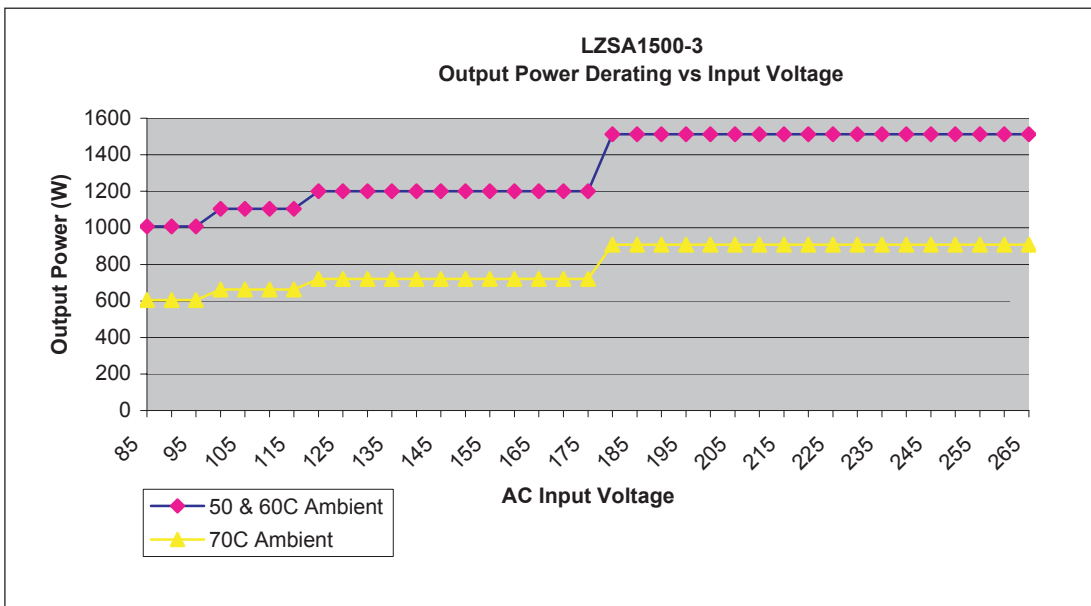
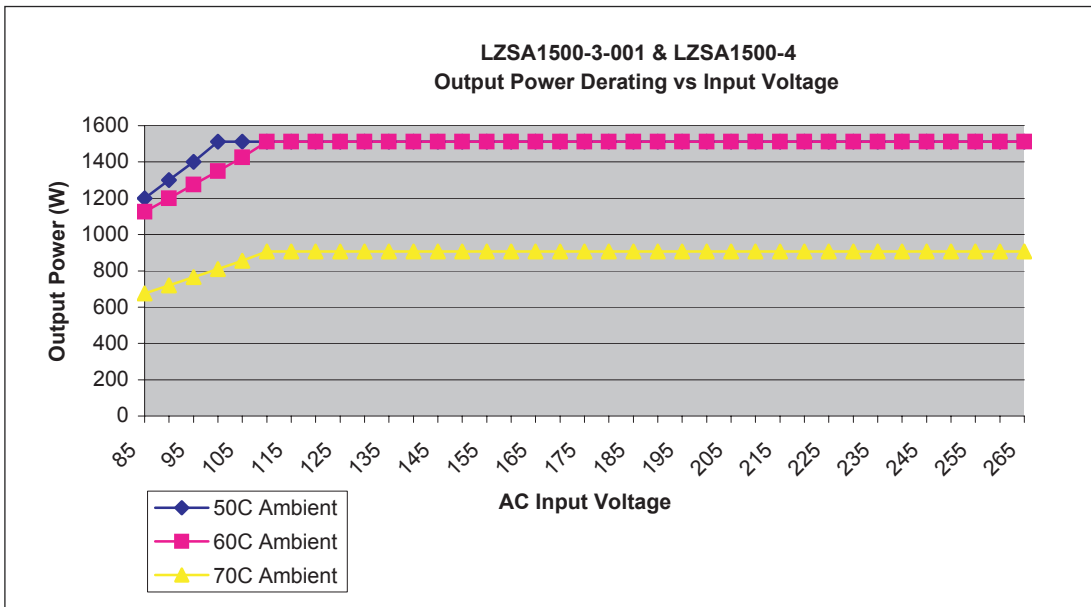



Configurable and Modular AC-DC Power Supplies

These products offer flexibility in the extreme because they are configured or assembled to order and offer a rapid and cost effective way to provide the exact set of outputs required for your equipment. Non-standard output voltages are easily catered for. Output power levels range from 100W to 1500W and up to 16 outputs are possible. Many signal options are available. Most models have medical approval. Suitable for many types of equipment including general industrial machinery, factory automation, broadcast, displays and medical equipment.

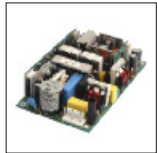

NV100 Series 100W Quad Output

Page No.

99



NV175/180/200 Series 175/180/200W Up to 5 Outputs

102



NV175M Series 180/200W Up to 5 Outputs

107

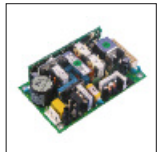

NVM175 Series 180W Single Output

110

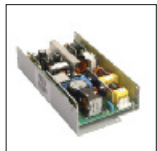

NV300 Series 300W Up to 5 Outputs

112



NV350/700 Series 350 - 1150W Up to 8 Outputs

117



Vega Series 450 - 900W Up to 10 Outputs

122



Vega Lite Series 450 - 900W Up to 10 Outputs

127



Alpha 1000/1500 Series 1000 - 1500W Up to 16 Outputs

132



- High Efficiency
- 4 Outputs
- Fits 1U Applications
- 3 Year Warranty
- Open frame or cased

NV-100

100 Watts

AC-DC flexible power solution

Key Market Segments & Applications

Instrumentation	Broadcast
Automation	ATE
Security	Industrial Computing
Network Servers and Routers Lifesciences/Laboratory	

Features and Benefits

Features

- Low Profile
- Multiple output
- Single connector output

Benefits

- Fits 1U applications, less space in system
- Reduces number of power supplies in system
- Simple and error free connection

INPUT

Input Voltage	90 - 264Vac / 120 - 350Vdc	Input Frequency	45 - 63Hz (440Hz with reduced PFC - consult factory)
Input Harmonics	EN61000-3-2 compliant	Inrush Current	<40A at 25°C and 264Vac, (cold start)
Input Fuse	Time delay (not user accessible)	Power Factor	0.97 typical
Earth Leakage Current	123µA typical at 120Vac (60Hz), 257µA typical at 240Vac (60Hz)		

ISOLATION

Input to Output	Reinforced	4.3kV (dc)		
Input to Earth	Basic	2.3 kV (dc)	Output to Earth	200 V (dc)

QUICK SELECTOR - preferred configurations

Model	CH1	CH2	CH3	CH4
NVA1-453TT	5V / 10A	3.3V / 8A	12V / 3A	-12V / 1A
NVA1-453FF	5V / 10A	3.3V / 8A	15V / 3A	-15V / 1A
NVA1-4G5TT	24V / 4A	5V / 5A	12V / 3A	-12V / 1A
NVA1-4G5FF	24V / 4A	5V / 5A	15V / 3A	-15V / 1A

Additional variants available (depending on volume) - 'Build to Order' - see below

AVAILABLE OUTPUTS

Channel 1	Adjustment Range	Channel 2	Adjustment Range	Channel 3	Adjustment Range	Channel 4 ₂	Adjustment Range
5 5V / 10A ₁	4.75 - 5.25V	3 3.3V / 8A	3.14 - 3.46V	T 12V / 3A F 15V / 3A G 24.5V / 1.5A	Fixed Fixed Fixed	T -12V / 1A ₃ F -15V / 1A ₃	Fixed Fixed
G 24V / 4A	23 - 25V	5 5V / 5A	3.3 - 5.5V	T 12V / 3A F 15V / 3A	Fixed Fixed	T -12V / 1A F -15V / 1A	Fixed Fixed

1. 5V ch 1/3.3V ch 2 combined power must not exceed 60W 2. Follow characters in red by 'P' for positive channel 4 3. If channel 3 = 24V (G), channel 4 must be 'P'

Other output options are available, please contact factory with your requirements.



OUTPUT SPECIFICATION

Remote Sense	Yes	Channels 1 & 2 - Max 0.5V total line drop.
Total Regulation	1%	Including Line (for 90-264Vac input change), Load (for 0-100% load change) and Cross (for 0-100% load change on any other output) regulation. (5% for channels 3 & 4)
Ripple & Noise	1%	(or 50mV if higher) pk-pk, using EIAJ test method & 20MHz bandwidth 1.5% on channel 4 for 5V channel 1 configs.
Voltage Accuracy	±1%	±5% for Channels 3 & 4 (with Channel 1 set to nominal voltage)
Turn on Time	1.5s max	at 90 Vac & 100% rated output power
Efficiency	up to 90%	configuration dependent
Hold up	16ms min	at 90 Vac
Min Load	None	on any output. (For models with 12V or 15V Ch3, a load ≥ 1A is required on Ch3 to keep it in full regulation when Ch1+Ch2 output power ≥ 50W.)
Transient Response	<4%	of set voltage for 50% load change (in 50µs within the range 25 - 100% load)
Recovery	<500µs	for recovery to 1% of set voltage
Short circuit protection	Yes	
Over Temperature protection	Yes	
Over Voltage Protection	Yes	See Application Notes for details
Ch1 Good Signal	Optional	Contact factory for details

HOW TO CREATE A PRODUCT CODE

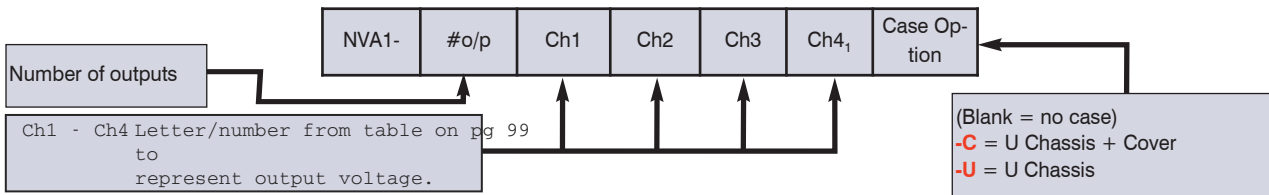

- For Positive Output Channel 4, follow chosen letter by 'P'.
For example, FP channel 4 = +15V / 1A

Confirm availability of created product code with the factory

ENVIRONMENT

Temperature	0°C to 50°C operational, -40°C to 85°C storage (max 12 months). Full load, with 2m/s air blown from input to output (approximately 10CFM)
Convection Rating	50W at 50°C. Max 50% output current on any output. See Application note for details
Derating	50°C to 70°C derate each output by 2.5% per °C
Low Temp Startup	-20°C
Humidity	5 - 95% RH non condensing
Shock	±3 x 30g shocks in each plane, total 18 shocks 30g shock = 11ms (+/-0.5msec), half sine Conforms to EN60068-2-27, EN60068-2-47, IEC68-2-27, IEC68-2-47, JIS C0041-1987. Conforms to MIL-STD-810E/F, Method 516.5, Pro I, IV, VI
Vibration	Single axis 10 - 500 Hz at 2g (sweep and endurance at resonance) in all 3 planes Conforms to EN60068-2-6, IEC68-2-6 Conforms to MIL-STD-810E, Method 514.4, Pro I, Cat 1,9
Altitude	-200 to 3,000 metres operational (-200 to 5000m storage/transportation)
Pollution	Degree 2, Material group IIIb

IMMUNITY EN61000-6-2:2001

Criteria

Electrostatic Discharge	EN61000-4-2	Level 4	Air discharge 15kV Contact discharge 8kV Not applicable to open frame units	A
Electromagnetic Field	EN61000-4-3	Level 3	(12V/m)	A
Fast / Burst Transient	EN61000-4-4	Level 3	ac input tested to 2.2kV dc output tested to 1.1kV	A
Surge Immunity	EN61000-4-5	Level 3	Common mode - 2.2kV Differential - 1.1kV	A
Conducted RF Immunity	EN61000-4-6	Level 3	(12V)	A
Power Frequency Magnetic Field	EN61000-4-8	Level 4	(30A/m)	A
Voltage Dips, Variations, Interruptions	EN61000-4-11	Class 3	Criteria B for 5 sec interruption	A



EMISSIONS EN61000-6-3:2001, EN60601-1-2:2001

Radiated Electric Field	EN55011, EN55022	(as per CISPR.11/22) Class B, FCC47 part 15 subpart B see application note for details
Conducted Emissions	EN55011, EN55022	(as per CISPR.11/22) Class B, FCC47 part 15 subpart B
Conducted Harmonics	EN61000-3-2	Class A
Flicker	EN61000-3-3	Compliant - d _{max} only

SAFETY APPROVALS

	Date	Amendments	Date	Amendments
EN 60950-1	2006		CSA 22.2 No 60950-1	2003
UL 60950-1	2007		IEC 60950-1*	2005
CE Mark	LV Directive 2006/95/EC (EN60950-1)			
* CB certificate and Report available on request			Check with factory for status of approvals	

OUTLINE & CONNECTION DRAWINGS

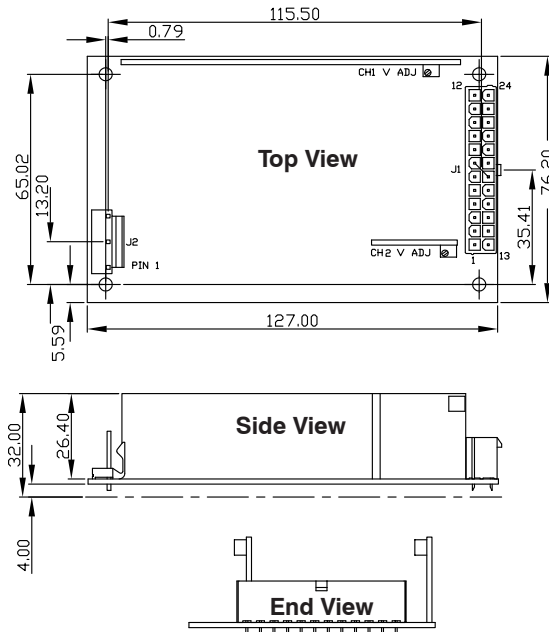

J2

PIN	FUNCTION
1	EARTH
2	NOT CONNECTED
3	LIVE
4	NOT CONNECTED
5	NEUTRAL

Weights (+/-80g)
 open frame = 250g
 '-U' = 350g
 '-C' = 400g

J1

PIN	FUNCTION	PIN	FUNCTION
12	NOT CONNECTED	24	NOT CONNECTED
11	NOT CONNECTED	23	NOT CONNECTED
10	CH1 OUTPUT	22	CH1 POWER GOOD
9	CH1 OUTPUT	21	CH1 OUTPUT
8	CH1 OUTPUT	20	CH1 OUTPUT
7	+SENSE CH1	19	-SENSE CH1
6	0V COMMON	18	0V COMMON
5	0V COMMON	17	0V COMMON
4	CH2 OUTPUT	16	0V COMMON
3	CH2 OUTPUT	15	CH2 OUTPUT
2	+SENSE CH2	14	-SENSE CH2
1	CH3 OUTPUT	13	CH4 OUTPUT

MATING PARTS (MOLLEX OR EQUIVALENT)

CONN	HOUSING	PINS
J1	39-01-2245	44476-3112
J2	09-50-8051	08-52-0113

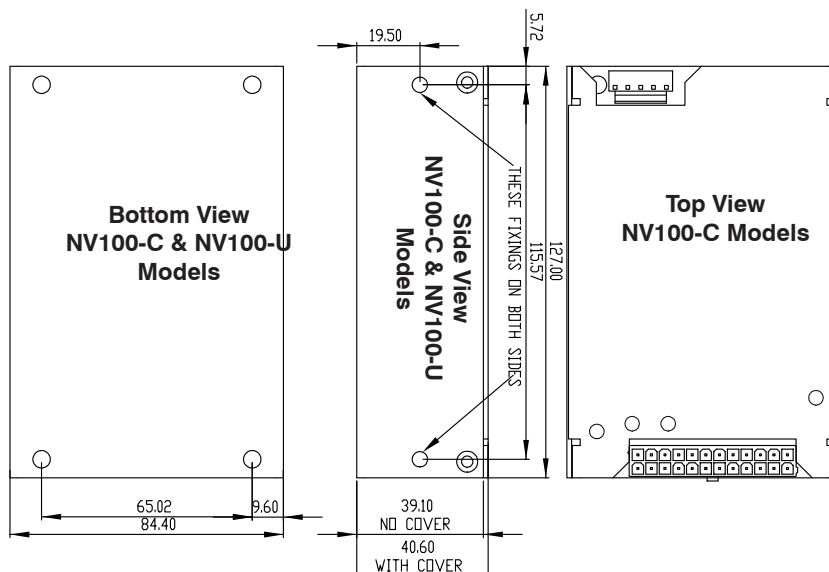

Notes 1. All customer fixings M3 2. Maximum Penetration 4.5mm 3. Maximum torque 0.9Nm 4. All tolerances +/-0.5mm



- High Efficiency
- High Power Density (9.3W/in³)
- Up to 5 outputs
- No minimum load
- Fits 1U applications
- Medical Approval
- 3 Year Warranty
- Temperature controlled Fan Option

Key Market Segments & Applications

- | | |
|-----------------------------|-------------------------|
| Instrumentation | Broadcast |
| Medical | ATE |
| Automation | Industrial Computing |
| Security | Lifesciences/Laboratory |
| Network Servers and Routers | |

NV-175

175/180/200 Watts

AC/DC Flexible Power Solution

Features and Benefits

Features

- High Efficiency
- Low profile
- High Power Density

Benefits

- Minimises heat in system
- Fits 1U applications
- Less Space

INPUT

Input Voltage	90 - 264Vac / 120 - 350Vdc	Input Frequency	45 - 63Hz (440Hz with reduced PFC - consult factory)
Input Harmonics	EN61000-3-2 compliant	Inrush Current	<40A at 25°C and 264Vac, (cold start)
Input Fuse	Fast acting (not user accessible)	Power Factor	0.97 typical
Earth Leakage Current	123µA max at 120Vac (60Hz), 257µA max at 240Vac (60Hz) Worst case leakage current is less than 300µA at 264Vac, 63Hz (normal condition, 500µA Single Fault Condition)		

AVAILABLE OUTPUTS

Channel 1	Adjustment Range	Channel 2 ₁	Adjustment Range	Channel 3 ₃	Adjustment Range	Channel 4 ₄	Adjustment Range
S 5V / 25A ₂	5 - 5.5V	1 1.8V / 15A	0.9 - 2.5V	T 12V / 5A F 15V / 5A G 24V / 2.5A O Omit	12 - 15V 12 - 15V 18 - 24V	T -12V / 1A	Fixed
		2 2.7V / 15A	2.5 - 3.3V			F -15V / 1A	Fixed
		3 3.3V / 15A	2.5 - 3.3V			3H -3.3V / 2A ₉	Fixed
T 12V / 15A F 15V / 12A	12 - 15V ₅ 12 - 15V ₆	5 5V / 10A ₁₀ O Omit	3.3 - 5.5V	O Omit	18 - 24V	5H -5V / 2A ₉	Fixed
G 24V / 7.5A	24 - 28V ₇	5 5V / 8A ₈ O Omit	3.3 - 5.5V			TH -12V / 2A ₉	Fixed
		O Omit				FH -15V / 2A ₉	Fixed
						OH Fan supply only O Omit	

- | | | |
|---|--|--|
| 1. 1.8V, 2.7V, 3.3V channel 2 only available with 5V Channel 1
5V/10A channel 2 only available with 12V or 15V Channel 1
5V/8A channel 2 only available with 24V Channel 1. | 3. Follow letters in red by 'Y' for negative output channel 3.
4. Follow letters in red by 'P' for positive output channel 4. | 7. 24 - 24.5V if 5V channel 2 fitted
24 - 26V if 24V channel 3 fitted. |
| 2. Maximum combined output current from Ch1 & Ch2 = 25A
Models with 5V channel 1 are limited to 175W output power | 5. 12 - 12.5V if 24V channel 3 fitted.
6. 14.5 - 15V if 24V channel 3 fitted. | 8. 7A max with '-F' or '-I' option.
9. 1.5A max with '-F' or '-I' option.
10. 9A max with '-F' or '-I' option. |

Other output options are available, please contact factory with your requirements.

ISOLATION

Input to Output	Reinforced	4.3kV (dc)	Note: Basic for IEC/EN/UL/CSA60601-1. Medical Reinforced version available, contact factory for details	
Input to Earth	Basic	2.3 kV (dc)	Output to Earth	200 V (dc)



OUTPUT SPECIFICATION		
Remote Sense	Yes	Channels 1 & 2 - Max 0.5V total line drop.
Total Regulation	1%	Including Line (for 90-264Vac input change), Load (for 0-100% load change) and Cross (for 0-100% load change on any other output) regulation
Ripple & Noise	1%	(or 50mV if higher) pk-pk, using EIAJ test method & 20MHz bandwidth
Voltage Accuracy	±1%	±4% for Channel 4 with 'T' or 'F' type outputs, +4%/-3% for all other Ch 4
Turn on Time	1.5s max	at 90 Vac & 100% rated output power
Efficiency	up to 90%	configuration dependent
Hold up	16ms min	at 90 Vac
Min Load	None	on any output
Transient Response	<4%	of set voltage for 50% load change (in 50µs within the range 25 - 100% load)
Recovery	<500µs	for recovery to 1% of set voltage
Short circuit protection	Yes	
Over Temperature protection	Yes	
Over Voltage Protection	Yes	See Application Notes for details
Ch1 Good Signal	Yes	Provides a Logic 'Low' signal after Channel 1 output is within 90% (±5%) of nominal.
Peak Output Power	200W	Single output units with 12V, 15V or 24V (T, F or G). Average output power must not exceed 180W over any 5 minute period.

HOW TO CREATE A PRODUCT CODE

NV1-	#o/p	Ch1	Ch2	Ch3 ₂	Ch4 ₃	Global Option	Case Option	Connector Option
	Number of outputs (excluding standby supply)	Ch1 - Ch4 Letter/number from table on pg 102 to represent output voltage.						(Blank = standard, vertical connector) -R = Right angled connector (see handbook for -R connection and mechanical details)
							(Blank = no case) -C = U Chassis + Cover -U = U Chassis -F = End fan + case ₁ -I = End fan + case + IEC inlet ₁	
							(Blank = no option) -N = 5V/2A -N1 = 12V/1A -N2 = 13.5/1A -N3 = 5V/2A ATX compatible -N4 = 12V/1A ATX compatible	

1. Needs 0H, 3H, 5H, TH or FH type channel 4.
The fan speed is temperature dependent, ensuring optimum cooling and lowest audible noise.
 2. For Negative Output Channel 3, follow chosen letter by 'Y'. For example, TY channel 3 = -12V / 5A
 3. For Positive Output Channel 4, follow chosen letter by 'P'. For example, TP channel 4 = +12V / 1A
 Confirm availability of created product code with the factory

QUICK SELECTOR - preferred configurations						
Model	CH1	CH2	CH3	CH4	CH5	Global Option ₁
NV1-1T000	12V / 15A	-	-	-	-	No
NV1-1G000	24V / 7.5A	-	-	-	-	No
NV1-453TT	5V / 25A	3.3V / 15A	12V / 5A	-12V / 1A	-	No
NV1-453TT-N3	5V / 25A	3.3V / 15A	12V / 5A	-12V / 1A	5V / 2A	ATX (-N3)
NV1-453FF	5V / 25A	3.3V / 15A	15V / 5A	-15V / 1A	-	No
NV1-453FF-N3	5V / 25A	3.3V / 15A	15V / 5A	-15V / 1A	5V / 2A	ATX (-N3)
NV1-4G5TT	24V / 7.5A	5V / 8A	12V / 5A	-12V / 1A	-	No
NV1-4G5TT-N3	24V / 7.5A	5V / 8A	12V / 5A	-12V / 1A	5V / 2A	ATX (-N3)
NV1-4G5FF	24V / 7.5A	5V / 8A	15V / 5A	-15V / 1A	-	No
NV1-4G5FF-N3	24V / 7.5A	5V / 8A	15V / 5A	-15V / 1A	5V / 2A	ATX (-N3)

Above Units available on rapid delivery.

Additional variants available 'Build to Order' - see above

1. see page 104 for details of global option



GLOBAL SIGNALS (-N, -N1 and -N2 Option Models)	
Remote on/off	TTL logic level high inhibits all outputs (except Standby)
Power Good	Open collector output (referenced to PSU 0V). Turns on to indicate ac supply is good and output 1 is within regulation.
Standby Supply	Isolated supply, not affected by remote on/off -N option = 5V / 2A (2.5A peak) -N1 Option = 12V / 1A -N2 Option = 13.5V / 1A

GLOBAL SIGNALS (-N3 and -N4 Option Models)	
ATX Remote on/off	TTL logic level high or open circuit will inhibit all outputs (except Standby)
ATX Power Good	Logic high indicates ac supply is good and output 1 is within regulation.
Standby Supply	Common 0V with power supply. Not affected by ATX remote on/off -N3 Option = 5V / 2A -N4 Option = 12V / 1A.

IMMUNITY EN61000-6-2:2001				Criteria
Electrostatic Discharge	EN61000-4-2	Level 4	Air discharge 15kV Contact discharge 8kV Not applicable to open frame units	A
Electromagnetic Field	EN61000-4-3	Level 3	(12V/m)	A
Fast / Burst Transient	EN61000-4-4	Level 4	ac input tested to 4.4kV dc output tested to 2.2kV	A
Surge Immunity	EN61000-4-5	Level 3	Common mode - 2.2kV Differential - 1.1kV	A
Conducted RF Immunity	EN61000-4-6	Level 3	(12V)	A
Power Frequency Magnetic Field	EN61000-4-8	Level 4	(30A/m)	A
Voltage Dips, Variations, Interruptions	EN61000-4-11	Class 3	Criteria B for 5 sec interruption	A

EMISSIONS EN61000-6-3:2001, EN60601-1-2:2001		
Radiated Electric Field	EN55011, EN55022	(as per CISPR.11/22) Class B, FCC47 part 15 subpart B see application note for details. Additional filtering required for IEC inlet version.
Conducted Emissions	EN55011, EN55022	(as per CISPR.11/22) Class B, FCC47 part 15 subpart B
Conducted Harmonics	EN61000-3-2	Class A
Flicker	EN61000-3-3	Compliant - d _{max} only

ENVIRONMENT	
Temperature	0°C to 50°C operational, -40°C to 85°C storage (max 12 months). Full load, with either 'F' option fitted or 2m/s air blown from input to output (approximately 10CFM)
Convection Rating	See Application note for details
Derating	50°C to 70°C derate each output by 2.5% per °C
Low Temp Startup	-20°C
Humidity	5 - 95% RH non condensing
Shock	±3 x 30g shocks in each plane, total 18 shocks 30g shock = 11ms (+/-0.5msec), half sine Conforms to EN60068-2-27, EN60068-2-47, IEC68-2-27, IEC68-2-47, JIS C0041-1987. Conforms to MIL-STD-810E/F, Method 516.5, Pro I, IV, VI
Vibration	Single axis 10 - 500 Hz at 2g (sweep and endurance at resonance) in all 3 planes Conforms to EN60068-2-6, IEC68-2-6 Conforms to MIL-STD-810E, Method 514.4, Pro I, Cat 1,9
Altitude	3,000 metres operational
Pollution	Degree 2, Material group IIIb

SAFETY APPROVALS					
	Date	Amendments		Date	Amendments
EN 60950-1	2006		EN 61010-1	2001	
UL 60950-1	2007		IEC 61010-1*	2001	
CSA 22.2 No 60950-1	2003		IEC 60601-1*	1988	
IEC 60950-1*	2005		EN 60601-1	1990	A1, A2
CE Mark	LV Directive 2006/95/EC (EN60950-1)		UL 60601-1	2003	with revisions 2006
* CB certificate and Report available on request			Check with factory for status of approvals		



OUTLINE & CONNECTION DRAWINGS

All drawings relate to both 175W and 180W versions

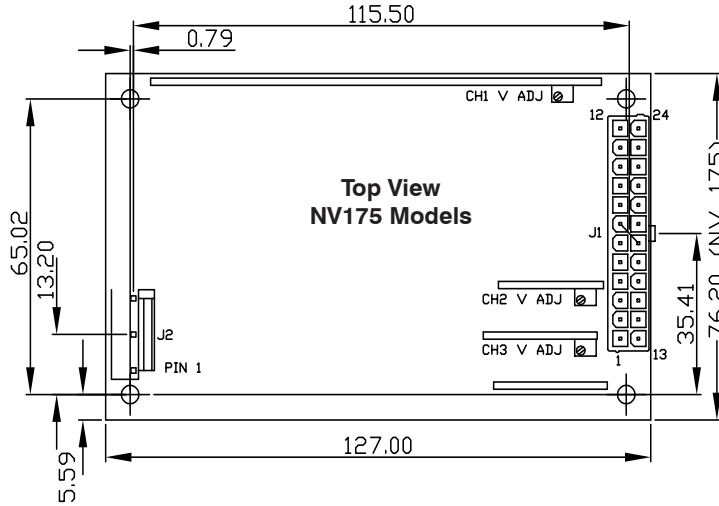

J2	
PIN	FUNCTION
1	EARTH
2	NOT CONNECTED
3	LIVE
4	NOT CONNECTED
5	NEUTRAL

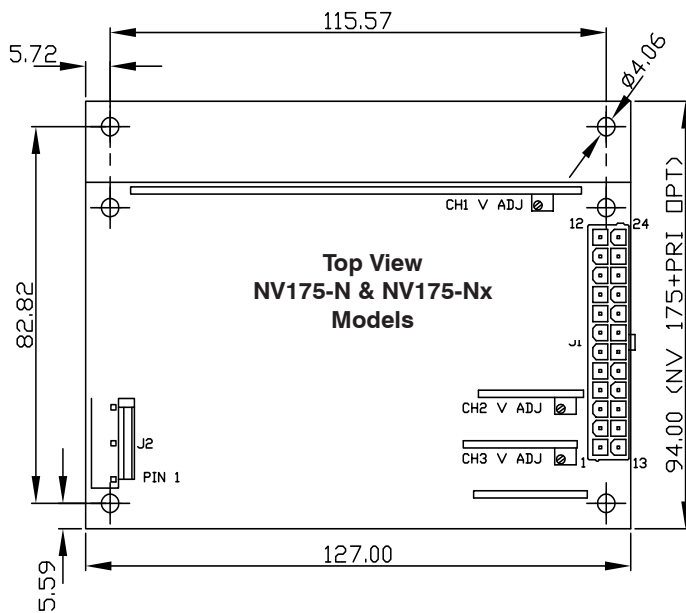

J1			
PIN	FUNCTION	PIN	FUNCTION
12	STANDBY +Ve	24	STANDBY RETURN
11	POWER GOOD	23	REMOTE ON/OFF
10	CH1 OUTPUT	22	CH1 POWER GOOD
9	CH1 OUTPUT	21	CH1 OUTPUT
8	CH1 OUTPUT	20	CH1 OUTPUT
7	+SENSE CH1	19	-SENSE CH1
6	0V COMMON	18	0V COMMON
5	0V COMMON	17	0V COMMON
4	CH2 OUTPUT	16	0V COMMON
3	CH2 OUTPUT	15	CH2 OUTPUT
2	+SENSE CH2	14	-SENSE CH2
1	CH3 OUTPUT	13	CH4 OUTPUT

MATING PARTS (MOLEX OR EQUIVALENT)

CONN	HOUSING	PINS
J1	39-01-2245	44476-3112
J2	09-50-8051	08-52-0113

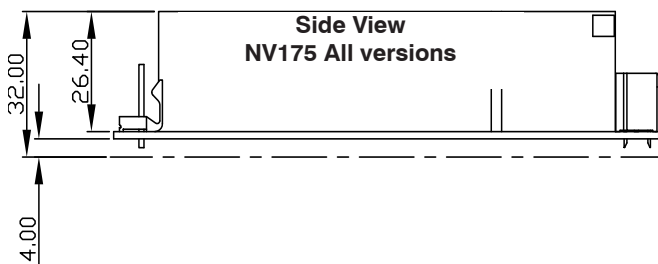

End View

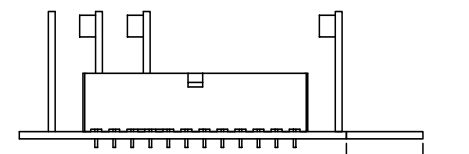

THIS PORTION FOR GLOBAL OPTION ONLY

Notes 1. All customer fixings M3

2. Maximum Penetration 4.5mm

3. Maximum torque 0.9Nm

4. All tolerances +/-0.5mm



OUTLINE & CONNECTION DRAWINGS

CONTINUED

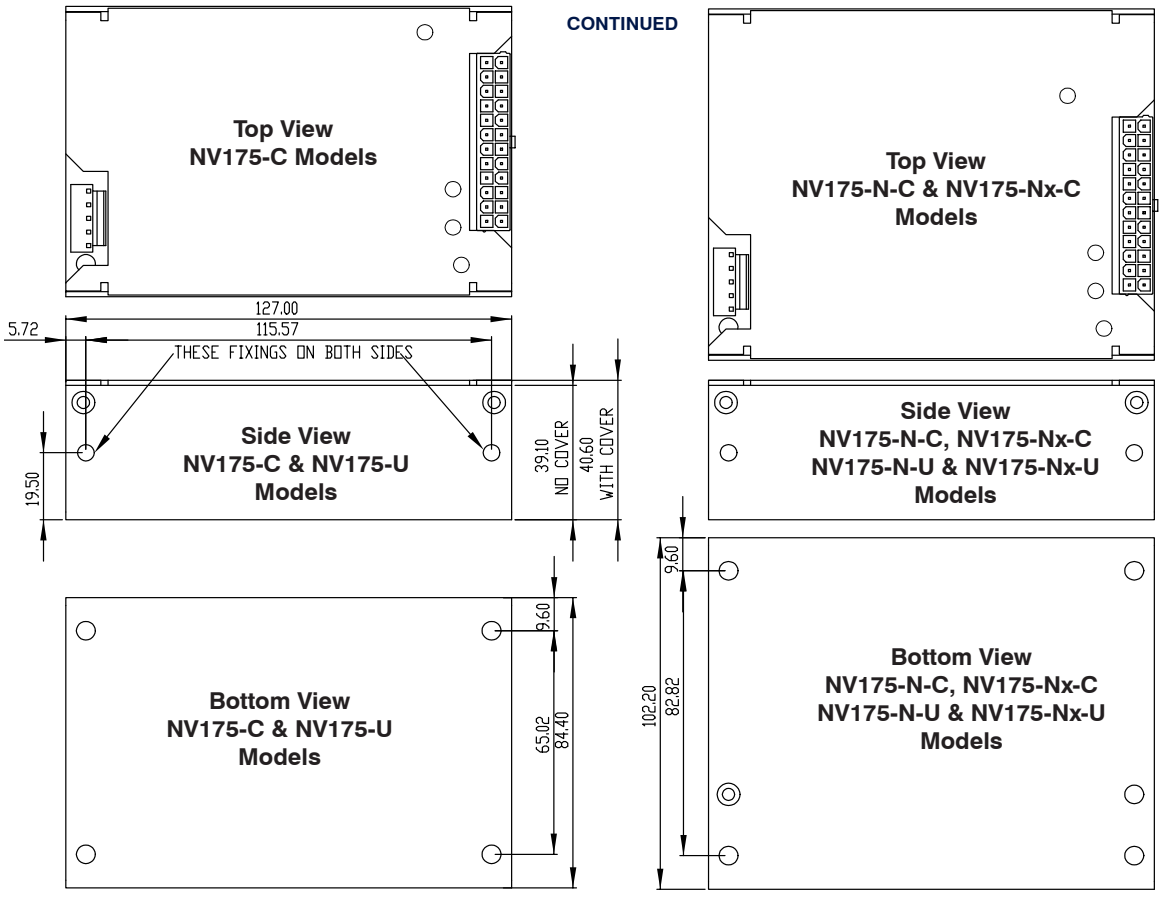

NV-175 units with fan (-F / -I)

All drawings relate to both 175W and 180W versions

WITHOUT GLOBAL OPTION

WITH GLOBAL OPTION

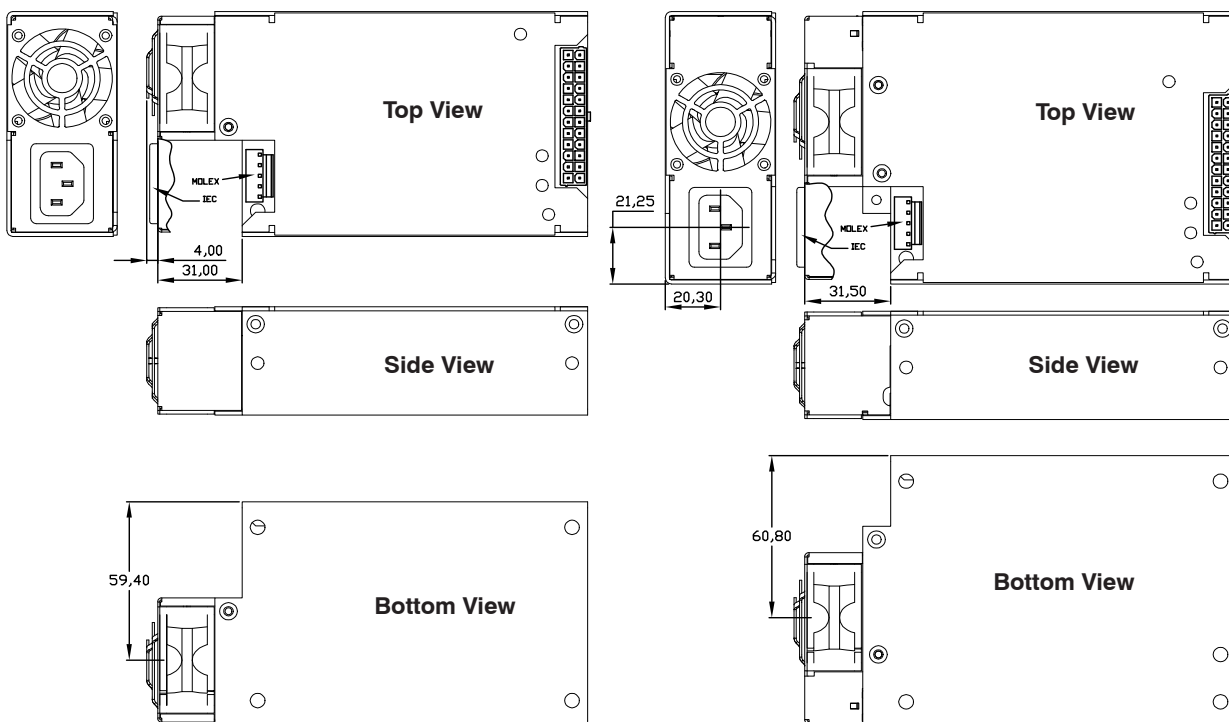

Other dimensions same as cases without fans (above)

- Notes 1. All customer fixings M3
- 2. Maximum Penetration 4.5mm
- 3. Maximum torque 0.9Nm
- 4. All tolerances +/-0.5mm



- Reinforced Input to Output Isolation for IEC60601
- Low Earth Leakage and Class B EMC
- Medical Approval
- High Efficiency
- High Power Density (9.3W/in³)
- Up to 3 outputs
- No minimum load
- Fits 1U applications
- 3 Year Warranty

NV-Power Medical

180/200 Watts, flexible power solution

Key Market Segments & Applications

Medical	Broadcast
Instrumentation	ATE
Automation	Industrial Computing
Security	Lifesciences/Laboratory
Network Servers and Routers	

Features and Benefits

Features

- High Efficiency
- Low Profile
- High Power Density

Benefits

- Minimises heat in system
- Fits 1U applications
- Less Space

INPUT			
Input Voltage	90 - 264Vac (100 - 240Vac nominal)	Input Frequency	45 - 63Hz
Input Harmonics	EN61000-3-2 compliant	Inrush Current	<40A at 25°C and 264Vac, (cold start)
Input Fuse	Fast acting (not user accessible)	Power Factor	0.97 typical
Earth Leakage Current	123µA max at 120Vac (60Hz), 257µA max at 240Vac (60Hz). Worst case leakage current is less than 300µA at 264Vac, 63Hz (normal condition, 500µA Single Fault Condition) Lower leakage versions available. Contact sales office for details		

ISOLATION			
Input to Output	Reinforced 4kV (ac)	type tested to 4kVac (equivalent to 5.7kVdc), production tested to 4.3kV (dc)	
Input to Earth	Basic	2.3 kV (dc)	Output to Earth 200 V (dc)

QUICK SELECTOR - preferred configurations				
Model	CH1	CH3	CH4	
NV1-1T000-M	12V / 15A	-	-	
NV1-1G000-M	24V / 7.5A	-	-	
NV1-3G0TT-M	24V / 7.5A	12V / 5A	-12V / 1A	
NV1-3G0FF-M	24V / 7.5A	15V / 5A	-15V / 1A	

Above Units available on rapid delivery.

Additional variants available 'Build to Order' - see below

AVAILABLE OUTPUTS						
Channel 1	Adjustment Range	Channel 2	Channel 3 ₁	Adjustment Range	Channel 4 ₂	Adjustment Range
T 12V / 15A	12 - 15V ₃	Not available	T 12V / 5A	12 - 15V	T -12V / 1A	Fixed
F 15V / 12A	12 - 15V ₄		F 15V / 5A	12 - 15V	F -15V / 1A	Fixed
G 24V / 7.5A	24 - 28V ₅		G 24V / 2.5A	18 - 24V	3HP +3.3V / 2A ₆	Fixed
			O Omit		5HP +5V / 2A ₆	Fixed
					TH -12V / 2A ₆	Fixed
					FH -15V / 2A ₆	Fixed
					OH Fan supply only	
					O Omit	

1. Follow letters in red by 'Y' for negative output channel 3.

2. Follow letters in red by 'P' for positive output channel 4.

3. 12 - 12.5V if 24V channel 3 fitted.

4. 14.5 - 15V if 24V channel 3 fitted.

5. 24 - 26V if 24V channel 3 fitted.

6. 1.5A max if fitted with '-F' option.

Other output options are available, please contact factory with your requirements.



OUTPUT SPECIFICATION		
Remote Sense	Yes	Channel 1 - Max 0.5V total line drop.
Total Regulation	1%	Including Line (for 90-264Vac input change), Load (for 0-100% load change) and Cross (for 0-100% load change on any other output) regulation
Ripple & Noise	1%	(or 50mV if higher) pk-pk, using EIAJ test method & 20MHz bandwidth
Voltage Accuracy	±1%	±4% for Channel 4 with 'T' or 'F' type outputs, +4%/-3% for all other Ch 3
Turn on Time	1.5s max	at 90 Vac & 100% rated output power
Efficiency	up to 90%	configuration dependent
Hold up	16ms min	at 90 Vac
Min Load	None	on any output
Transient Response	<4%	of set voltage for 50% load change (in 50µs within the range 25 - 100% load)
Recovery	<500µs	for recovery to 1% of set voltage
Short circuit protection	Yes	
Over Temperature protection	Yes	
Over Voltage Protection	Yes	See Application Notes for details
Ch1 Good Signal	Yes	Provides a Logic 'Low' signal after Channel 1 output is within 90% (±5%) of nominal.
Peak Output Power	200W	Single output units. Average output power must not exceed 180W over any 5 minute period.

HOW TO CREATE A PRODUCT CODE

1. Needs 0H, 3H, 5H, TH or FH type channel 4. **The fan speed is temperature dependent, ensuring optimum cooling and lowest audible noise.**

2. For Negative Output Channel 3, follow chosen letter by 'Y'. For example, TY channel 3 = -12V / 5A

3. For Positive Output Channel 4, follow chosen letter by 'P'. For example, TP channel 4 = +12V / 1A

Confirm availability of created product code with the factory

ENVIRONMENT	
Temperature	0°C to 50°C operational, -40°C to 85°C storage (max 12 months). Full load, with either '-F' option fitted or 2m/s air blown from input to output (approximately 10CFM)
Convection Rating	See Application note for details
Derating	50°C to 65°C derate each output by 2.5% per °C
Low Temp Startup	-20°C
Humidity	5 - 95% RH non condensing
Shock	±3 x 30g shocks in each plane, total 18 shocks 30g shock = 11ms (+/-0.5msec), half sine Conforms to EN60068-2-27, EN60068-2-47, IEC68-2-27, IEC68-2-47, JIS C0041-1987. Conforms to MIL-STD-810E/F, Method 516.5, Pro I, IV, VI
Vibration	Single axis 10 - 500 Hz at 2g (sweep and endurance at resonance) in all 3 planes Conforms to EN60068-2-6, IEC68-2-6
Altitude	3,000 metres operational
Pollution	Degree 2, Material group IIIb

IMMUNITY EN61000-6-2:2001				Criteria
Electrostatic Discharge	EN61000-4-2	Level 4	Air discharge 15kV Contact discharge 8kV Not applicable to open frame units	A
Electromagnetic Field	EN61000-4-3	Level 3	(12V/m)	A
Fast / Burst Transient	EN61000-4-4	Level 4	(tested to 4.4kV)	A
Surge Immunity	EN61000-4-5	Level 3	Common mode - 2.2kV Differential - 1.1kV	A
Conducted RF Immunity	EN61000-4-6	Level 3	(12V)	A
Power Frequency Magnetic Field	EN61000-4-8	Level 4	(30A/m)	A
Voltage Dips, Variations, Interruptions	EN61000-4-11	Class 3	Criteria B for 5 sec interruption	A



EMISSIONS EN61000-6-3:2001, EN60601-1-2:2001

Radiated Electric Field	EN55011, EN55022	(as per CISPR.11/22) Class B, FCC47 part 15 subpart B (2005) see application note for details
Conducted Emissions	EN55011, EN55022	(as per CISPR.11/22) Class B, FCC47 part 15 subpart B (2005)
Conducted Harmonics	EN61000-3-2	Class A
Flicker	EN61000-3-3	Compliant - d _{max} only

SAFETY APPROVALS

	Date	Amendments		Date	Amendments
EN 60950-1	2006		EN 61010-1	2001	
UL 60950-1	2007		IEC 61010-1*	2001	
CSA 22.2 No 60950-1	2003		IEC 60601-1*	1988	A1, A2
IEC 60950-1*	2005		EN 60601-1	1990	A1, A2, A13
CE Mark	LV Directive 2006/95/EC (EN60950-1)		UL 60601-1	2003	with revisions 2006
* CB certificate and Report available on request			Check with factory for status of approvals		

OUTLINE & CONNECTION DRAWINGS

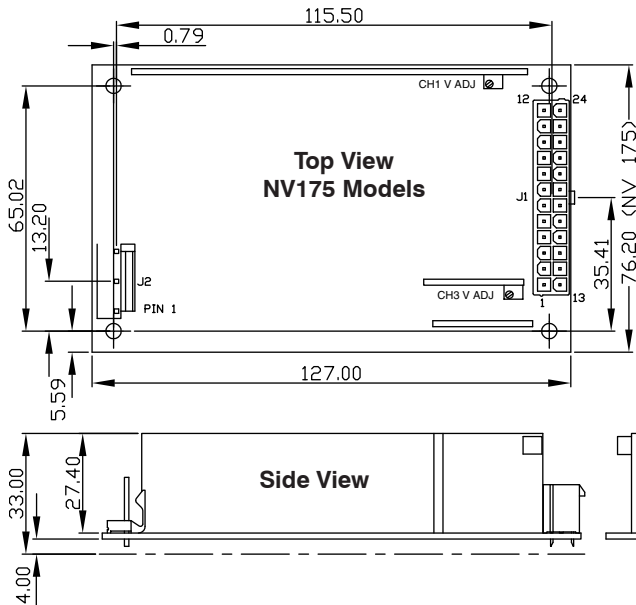

MATING PARTS (MOLEX OR EQUIVALENT)

CONN	HOUSING	PINS
J1	39-01-2245	44476-3112
J2	09-50-8051	08-52-0113

J1			
PIN	FUNCTION	PIN	FUNCTION
12	STANDBY +Ve	24	Do not connect
11	Do not connect	23	Do not connect
10	CH1 OUTPUT	22	CH1 POWER GOOD
9	CH1 OUTPUT	21	CH1 OUTPUT
8	CH1 OUTPUT	20	CH1 OUTPUT
7	+SENSE CH1	19	-SENSE CH1
6	0V COMMON	18	0V COMMON
5	0V COMMON	17	0V COMMON
4	Do not connect	16	0V COMMON
3	Do not connect	15	Do not connect
2	Do not connect	14	Do not connect
1	CH3 OUTPUT	13	CH4 OUTPUT

J2	
PIN	FUNCTION
1	EARTH
2	NOT CONNECTED
3	LIVE
4	NOT CONNECTED
5	NEUTRAL

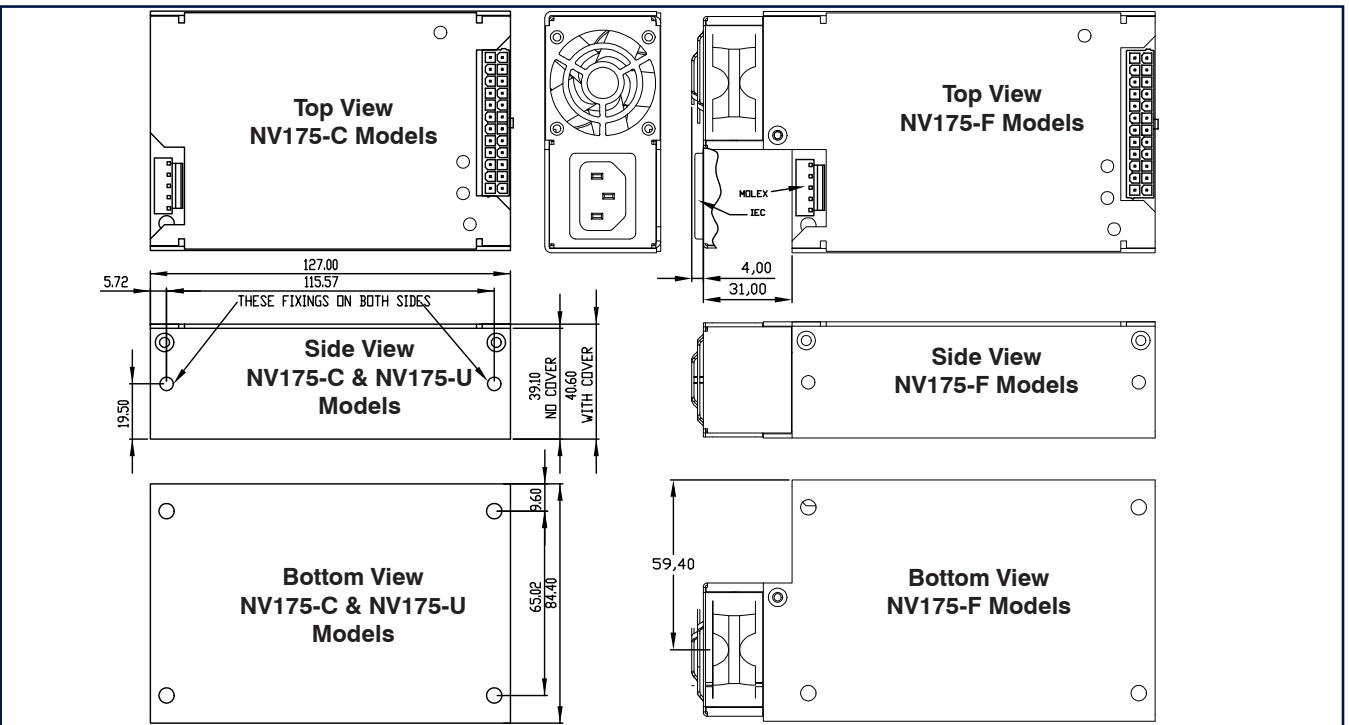

Notes 1. All customer fixings M3 2. Maximum Penetration 4.5mm 3. Maximum torque 0.9Nm 4. All tolerances +/-0.5mm

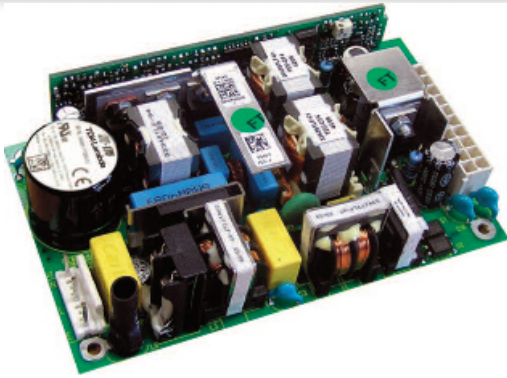

NV-Power Medical

180 Watts medical power supply for BF applications

- Reinforced Input to Output Isolation for IEC60601
- Very low Earth Leakage and Class B EMC
- Below 1W standby power
- Medical Approval (Designed for BF applications)
- 5" x 3" footprint
- Standby supply and remote on/off
- High Efficiency & High Power Density (9.3W/in³)
- No minimum load
- Fits 1U applications
- 3 Year Warranty

Key Market Segments & Applications

Medical	Security
Lifesciences/Laboratory	Network Servers and Routers
Instrumentation	Broadcast
Automation	ATE

Features and Benefits

Features

- Very low Earth Leakage and Class B EMC
- Dual Fusing
- Designed for BF medical applications

Benefits

- Meets medical leakage specs and achieves curve B EMC
- Simplifies system design, reduces cost
- Simplifies system design

INPUT

Input Voltage	90 - 264Vac (100 - 240Vac nominal)	Input Frequency	45 - 63Hz
Input Harmonics	EN61000-3-2 compliant	Inrush Current	<40A at 25°C and 264Vac, (cold start)
Input Fuse	Dual Fused, Fast acting (not user accessible)	Power Factor	0.97 typical
Earth Leakage Current	80µA max at 120Vac (60Hz), 170µA max at 240Vac (60Hz). Worst case leakage current is less than 200µA at 264Vac, 63Hz (normal condition, =330µA Single Fault Condition)		

HOW TO CREATE A PRODUCT CODE

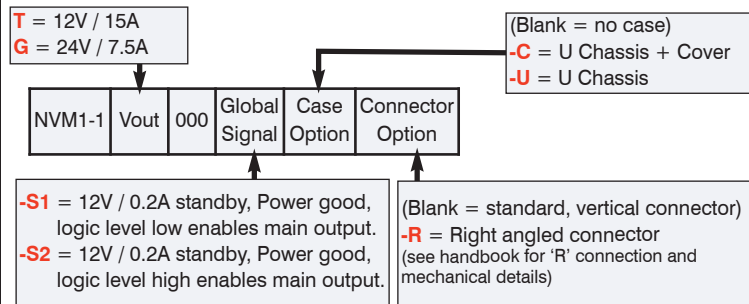

Confirm availability of created product code with the factory

SAFETY APPROVALS

	Date	Amendments
EN 60950-1	2006	
UL 60950-1	2007	
CSA 22.2 No 60950-1	2003	
IEC 60950-1*	2005	
CE Mark	LV Directive 2006/95/EC (EN60950-1)	
IEC 60601-1*	1988	A1, A2
EN 60601-1	1990	A1, A2, A13
UL 60601-1	2003	with revisions 2006

* CB certificate and Report available on request
Check with factory for status of approvals

ISOLATION

Input to Output	Reinforced	4.5kV (ac) type tested to 4.5kVac (equivalent to 6.3kVdc), production tested to 4.3kV (dc)
Input to Earth	Basic	1.5 kV (ac), 2.3 kV (dc)
Output to Earth		1.5 kV (ac)

QUICK SELECTOR

Model	CH1	Standby	Remote On/Off
NVM1-1T000-S1	12V/15A	12V/0.2A TTL high / OC to inhibit	
NVM1-1G000-S1	24V/7.5A		

IMMUNITY EN61000-6-2:2001

Criteria

Test	Standard	Level	Criteria
Electrostatic Discharge	EN61000-4-2	Level 4	A
Electromagnetic Field	EN61000-4-3	Level 3	A
Fast / Burst Transient	EN61000-4-4	Level 4	A
Surge Immunity	EN61000-4-5	Level 3	A
Conducted RF Immunity	EN61000-4-6	Level 3	A
Power Frequency Magnetic Field	EN61000-4-8	Level 4	A
Voltage Dips, Variations, Interruptions	EN61000-4-11	Class 3	A

EMISSIONS EN61000-6-3:2001, EN60601-1-2:2001

Test	Standard	Criteria
Radiated Electric Field	EN55011, EN55022	A (as per CISPR.11/22) Class B, FCC47 part 15 subpart B (2005) see application note for details
Conducted Emissions	EN55011, EN55022	A (as per CISPR.11/22) Class B, FCC47 part 15 subpart B (2005)
Conducted Harmonics	EN61000-3-2	Class A
Flicker	EN61000-3-3	Compliant - d _{max} only



OUTPUT SPECIFICATION			ENVIRONMENT	
Remote Sense	Yes	Channel 1 - Max 0.5V total line drop.	Temperature	0° to 50°C operational, -40°C to 85°C storage (max 12 months). Full load, with 1.5m/s air blown from input to output (approximately 10CFM)
Total Regulation	1%	Including Line (for 90-264Vac input change) and Load (for 0-100% load change)		
Ripple & Noise	1%	(or 50mV if higher) pk-pk, using EIAJ test method & 20MHz bandwidth	Convection Rating	See Application note for details
Voltage Accuracy	±1%		Derating	50° to 70°C derate each output by 2.5% per °C with 2.0m/s air blown from input to output.
Turn on Time	1.5s max	at 90 Vac & 100% rated output power	Low Temp Startup	-20°C
Efficiency	up to 90%		Humidity	5 - 95% RH non condensing
Hold up	16ms min	at 90 Vac	Shock	±3 x 30g shocks in each plane, total 18 shocks 30g shock = 11ms (+/-0.5msec), half sine Conforms to EN60068-2-27, EN60068-2-47, IEC68-2-27, IEC68-2-47, JIS C0041-1987. Conforms to MIL-STD-810E/F, Method 516.5, Pro I, IV, VI
Min Load	None	on any output		
Transient Response	<4%	of set voltage for 50% load change (in 50µs within the range 25 - 100% load)	Vibration	Single axis 10 - 500 Hz at 2g (sweep and endurance at resonance) in all 3 planes Conforms to EN60068-2-6, IEC68-2-6 Conforms to MIL-STD-810E, Method 514.4, Pro I, Cat 1,9
Recovery	<500µs	for recovery to 1% of set voltage		
Short circuit protection	Yes		Altitude	5,000metres operational (3,000 metres for IEC/EN/UL60601-1)
Over Temperature protection	Yes			
Over Voltage Protection	Yes	120-135% of Vout. Remove ac for 10 seconds then reapply to restart unit.	Pollution	Degree 2, Material group IIIb
Power good signal (J1, pin 12)	Yes	'S1' and 'S2' type global signals. Logic 'High' signal indicates ac supply is good and output 1 is within regulation. Provides minimum 4ms ac fail warning.		

OUTLINE & CONNECTION DRAWINGS

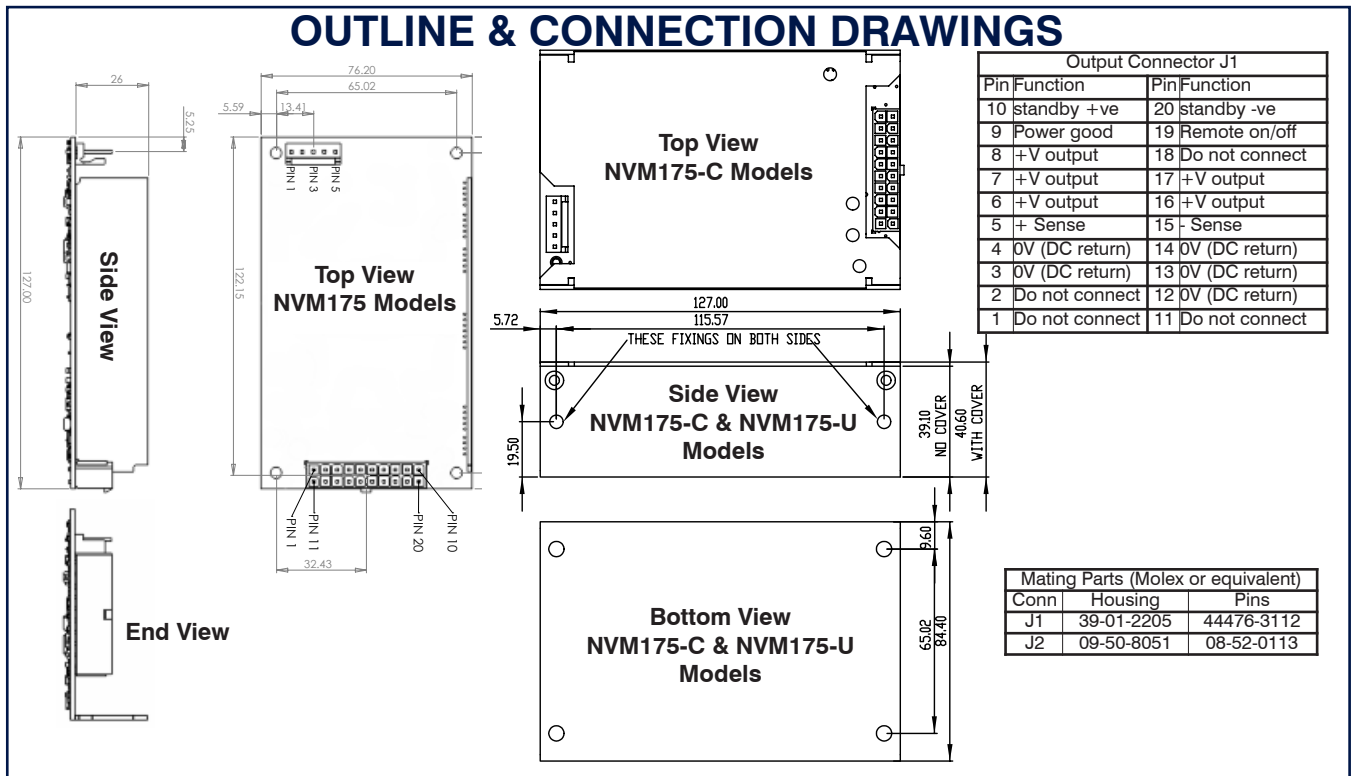

Notes 1. All customer fixings M3 2. Maximum Penetration 4.5mm 3. Maximum torque 0.9Nm 4. All tolerances +/-0.5mm



- High Efficiency
- High Power Density (8.3W/in³)
- Up to 5 outputs
- No minimum load
- Fits 1U applications
- Medical Approval
- 3 Year Warranty
- Temperature controlled Fan Option

NV-300

300 Watts
Flexible Power Solution

Key Market Segments & Applications

- | | |
|-----------------------------|-------------------------|
| Instrumentation | Broadcast |
| Medical | ATE |
| Automation | Industrial Computing |
| Security | Lifesciences/Laboratory |
| Network Servers and Routers | |

Features and Benefits

Features

- High Efficiency
- Low Profile
- High Power Density

Benefits

- Minimises heat in system
- Fits 1U applications
- Less Space

INPUT			
Input Voltage	90 - 264Vac / 120 - 350Vdc (Below 100Vac input, derate by 3W per Volt)	Input Frequency	45 - 63Hz (440Hz with reduced PFC - consult factory)
Input Harmonics	EN61000-3-2 compliant	Inrush Current	15A (typical) at 20°C and 264Vac, (cold start)
Input Fuse	6.3A, Fast acting (not user accessible)	Power Factor	0.97 typical
Earth Leakage Current	123µA max at 120Vac (60Hz), 257µA max at 240Vac (60Hz) Worst case leakage current is less than 300µA at 264Vac, 63Hz (normal condition, 500µA Single Fault Condition)		

AVAILABLE OUTPUTS											
Channel 1	Adjustment Range ₅	Channel 2 ₁	Adjustment Range ₅	Channel 3	Adjustment Range	Channel 4 ₃	Adjustment Range				
5 5V / 40A ₂	5 - 5.5V	1 1.8V / 15A	0.9 - 2.5V								
		2 2.7V / 15A	2.5 - 3.8V								
T 12V / 25A	12 - 13V	3 3.3V / 15A	2.5 - 3.8V	T 12V / 5A ₄	12 - 15V	3H -3.3V / 2A ₈	Fixed				
		2H 2.7V / 24A	2.5 - 3.8V					TH 12V / 8A ₆	12 - 15V	5H -5V / 2A ₈	Fixed
		3H 3.3V / 24A	2.5 - 3.8V					F 15V / 4A ₄	12 - 15V	TH -12V / 2A ₈	Fixed
G 24V / 12.5A	24 - 28V ₇	0 Omit	2.5 - 3.8V	FH 15V / 6.4A ₆	12 - 15V	FH -15V / 2A ₈	Fixed				
		5 5V / 10A	3.3 - 5.5V	G 24V / 2.5A	18 - 24V	0H Fan supply only					
		5H 5V / 16A	3.3 - 5.5V	0 Omit		0 Omit					
		0 Omit									
		5 5V / 8A	5 - 5.5V								
		5H 5V / 12.5A	5 - 5.5V								
		T 12V / 10A	12 - 15.5V								
		F 15V / 10A	12 - 15.5V								
		0 Omit									

- 1, 2, 3, 2H & 3H channel 2 only available with 5V channel 1.
5V / 10A channel 2 only available with 12 or 15V channel 1
5V / 8A channel 2 only available with 24V channel 1
- Maximum combined output current from Ch1 & Ch2 = 40A
- Follow letters in red by 'P' for positive output channel 4.
- 60W max output power
- Max voltage at the output (includes remote sense)
- 96W max output power
- 24 - 24.5V if 5V channel 2 fitted
24 - 26V if 24V channel 3 fitted
- 1.5A max if fitted with '-F' option.

Other output options are available, please contact factory with your requirements.



ISOLATION			
Input to Output	Reinforced	4.3kV (dc)	Note: Basic for IEC/EN/UL/CSA60601-1
Input to Earth	Basic	2.25 kV (dc)	Output to Earth 200 V (dc)

OUTPUT SPECIFICATION		
Remote Sense	Yes	Channels 1 & 2 - Max 0.5V total line drop.
Total Regulation	1.5%	For channels 1, 2 and 3 (2.5% for channel 4) Including Line (for 90-264Vac input change), Load (for 0-100% load change) and Cross (for 0-100% load change on any other output) regulation.
Ripple & Noise	1%	(or 50mV if higher) pk-pk, using EIAJ test method & 20MHz bandwidth 1.5% for units with 5V Channel 1
Voltage Accuracy	±1%	±5% for Channel 4
Turn on Time	1.5s max	at 90 Vac & 100% rated output power
Efficiency	up to 90%	configuration dependent
Hold up	16ms min	at 90 Vac
Min Load	None	on any output
Transient Response	<5%	of set voltage for 40% load change (in 50µs within the range 25 - 100% load)
Recovery	<500µs	for recovery to 1% of set voltage
Short circuit protection	Yes	
Over Temperature protection	Yes	
Over Voltage Protection	Yes	See Application Notes for details
Ch1 Good Signal	Yes	Provides a Logic 'Low' signal after Channel 1 output is within 90% (±5%) of nominal.
Output Power	300W	Total output power from all outputs (for Vin below 180Vac including standby supply) for Vin above 180Vac, max output power = 300W + standby supply

HOW TO CREATE A PRODUCT CODE

NVA3-	#o/p	Ch1	Ch2	Ch3	Ch4	Global Option	Case Option
	↑	↑	↑	↑	↑	↑	↑

Number of outputs (excluding standby supply)

Ch1 - Ch4 Letter/number from table on pg 112 to represent output voltage.

(Blank = no case)
-C = U Chassis + Cover
-U = U Chassis
-F = End fan + case,
-I = IEC input, End fan + case,

(Blank = no option)
-N3 = 5V/2A ATX compatible
-N4 = 12V/1A ATX compatible

1. Needs 0H, 3H, 5H, TH or FH type channel 4. **The fan speed is temperature dependent, ensuring optimum cooling and lowest audible noise.**

Confirm availability of created product code with the factory

QUICK SELECTOR - preferred configurations						
Model	CH1	CH2	CH3	CH4	CH5	Global Option ₁
NVA3-453TTH	5V / 40A	3.3V / 15A	12V / 5A	-12V / 2A	-	No
NVA3-453TTH-N3	5V / 40A	3.3V / 15A	12V / 5A	-12V / 2A	5V / 2A	ATX (-N3)
NVA3-350TTH	5V / 40A	-	12V / 5A	-12V / 2A	-	No
NVA3-350TTH-N3	5V / 40A	-	12V / 5A	-12V / 2A	5V / 2A	ATX (-N3)
NVA3-453FFH	5V / 40A	3.3V / 15A	15V / 5A	-15V / 2A	-	No
NVA3-453FFH-N3	5V / 40A	3.3V / 15A	15V / 5A	-15V / 2A	5V / 2A	ATX (-N3)
NVA3-350FFH	5V / 40A	-	15V / 5A	-15V / 2A	-	No
NVA3-350FFH-N3	5V / 40A	-	15V / 5A	-15V / 2A	5V / 2A	ATX (-N3)

Above Units available on rapid delivery.

See over for additional variants available 'Build to Order'

1. see page 114 for details of global option



GLOBAL SIGNALS (-N3 and -N4 Option Models)	
ATX Remote on/off	TTL logic level high or open circuit will inhibit all outputs (except Standby)
ATX Power Good	Logic high indicates ac supply is good and output 1 is within regulation.
Standby Supply	Common 0V with power supply. Not affected by ATX remote on/off -N3 Option = 5V / 2A -N4 Option = 12V / 1A.

IMMUNITY EN61000-6-2:2005, EN60601-1-2:2001				Criteria
Electrostatic Discharge	EN61000-4-2	Level 4	Air discharge 15kV Contact discharge 8kV Not applicable to open frame units	A
Electromagnetic Field	EN61000-4-3	Level 3	(12V/m)	A
Fast / Burst Transient (ac input)	EN61000-4-4	Level 4	(tested to 4.4kV)	A
Fast / Burst Transient (dc output)	EN61000-4-4	Level 4	(tested to 2.2kV)	A
Surge Immunity	EN61000-4-5	Level 3	Common mode - 2.2kV Differential - 1.1kV	A
Conducted RF Immunity	EN61000-4-6	Level 3	(12V)	A
Power Frequency Magnetic Field	EN61000-4-8	Level 4	(30A/m)	A
Voltage Dips, Variations, Interruptions	EN61000-4-11	Class 3	Criteria B for 5 sec interruption	A
Voltage Fluctuations	EN61000-4-14	Class 3	For 100 - 240V Nominal	A

EMISSIONS EN61000-6-3:2001, EN60601-1-2:2001		
Radiated Electric Field	EN55011, EN55022	(as per CISPR.11/22) Class B, FCC47 part 15 subpart B see app note for details
Conducted Emissions	EN55011, EN55022	(as per CISPR.11/22) Class B, FCC47 part 15 subpart B
Conducted Harmonics	EN61000-3-2	Class A
Flicker	EN61000-3-3	Compliant - d _{max} only

ENVIRONMENT	
Temperature	0°C to 50°C operational, -40°C to 85°C storage (max 12 months). Full load, with either '-F' option fitted or 1.5m/s air blown from input to output (approximately 10CFM)
Derating	50°C to 65°C derate each output by 2.5% per °C
Low Temp Startup	-20°C
Humidity	5 - 95% RH non condensing
Shock	±3 x 30g shocks in each plane, total 18 shocks 30g shock = 11ms (+/-0.5msec), half sine Conforms to EN60068-2-27, EN60068-2-47, IEC68-2-27, IEC68-2-47, JIS C0041-1987. Conforms to MIL-STD-810E/F, Method 516.5, Pro I, IV, VI
Vibration	Single axis 10 - 500 Hz at 2g (sweep and endurance at resonance) in all 3 planes Conforms to EN60068-2-6, IEC68-2-6 Conforms to MIL-STD-810E, Method 514.4, Pro I, Cat 1,9
Altitude	3,000 metres operational
Pollution	Degree 2, Material group 3

SAFETY APPROVALS					
	Date	Amendments		Date	Amendments
EN 60950-1	2006		EN 61010-1	2001	
UL 60950-1	2007		IEC 61010-1*	2001	
CSA 22.2 No 60950-1	2003		IEC 60601-1*	1988	A1, A2
IEC 60950-1*	2005		EN 60601-1	1990	A1, A2, A13
CE Mark	LV Directive 2006/95/EC (EN60950-1)		UL 60601-1	2003	with revisions 2006
* CB certificate and Report available on request			Check with factory for status of approvals		



OUTLINE & CONNECTION DRAWINGS

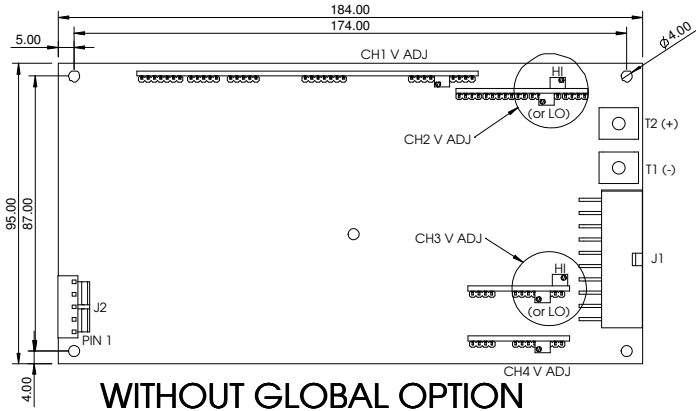

WITHOUT GLOBAL OPTION

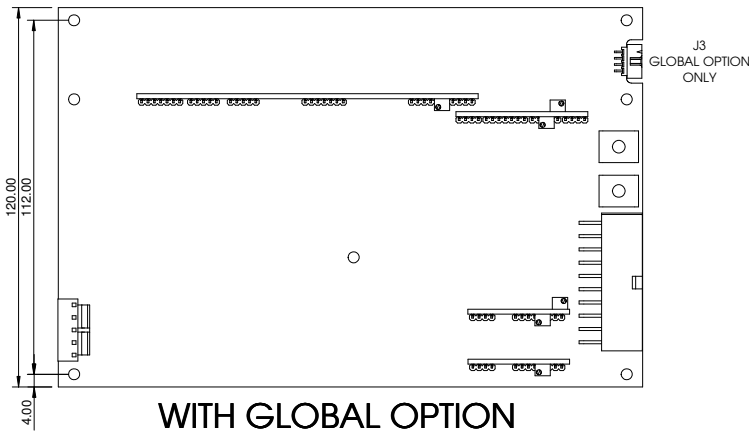

WITH GLOBAL OPTION

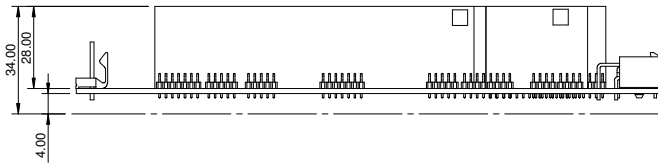

J2

PIN	CONNECTION
1	EARTH
2	NOT CONNECTED
3	LIVE
4	NOT CONNECTED
5	NEUTRAL

J1

PIN	CONNECTION	PIN	CONNECTION
11	0V COMMON	1	0V COMMON
12	0V COMMON	2	0V COMMON
13	CH2 +Ve	3	CH2 +Ve
14	CH2 +Ve	4	CH2 +Ve
15	+SENSE CH1	5	-SENSE CH1
16	+SENSE CH2	6	-SENSE CH2
17	CH1 GOOD	7	N/C
18	CH3 +Ve	8	CH3 +Ve
19	0V COMMON	9	0V COMMON
20	CH4 O/P	10	CH4 O/P

T1 & T2 (SEE TOP LEFT)

J3 (GLOBAL OPTION ONLY)

PIN	CONNECTION	PIN	CONNECTION
1	STANDBY -Ve	5	N/C
2	STANDBY +Ve	6	N/C
3	STANDBY -Ve	7	POWER GOOD
4	STANDBY +Ve	8	REM ON/OFF

MATING PARTS (MOLEX OR EQUIVALENT)

CONNECTOR	HOUSING	CRIMP PIN
J1	39-01-2205	44476-3112
J2	09-50-8051	08-52-0113
J3	51110-0860	50394
T1 & T2	N/A	TAG 19073-0165

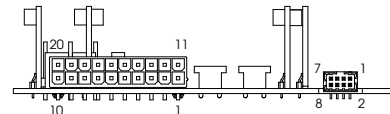

Notes 1. All customer fixings M3

2. Maximum Penetration 4.5mm

3. Maximum torque 0.9Nm

4. All tolerances +/-0.5mm



OUTLINE & CONNECTION DRAWINGS

OPEN FRAME

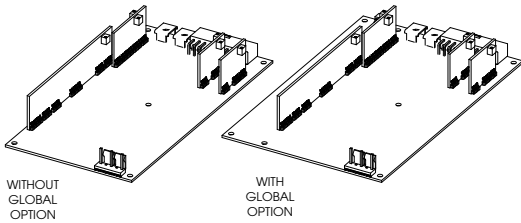

'U' CHANNEL
(COVER OPTIONAL)

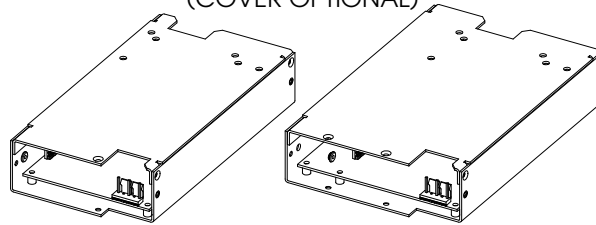

FAN OPTION

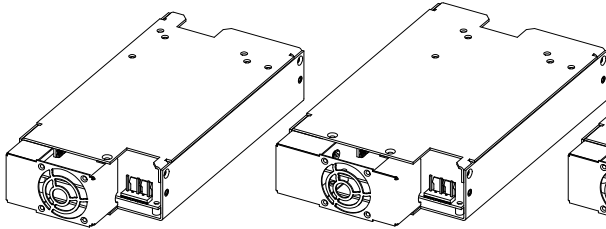

FAN+IEC OPTION

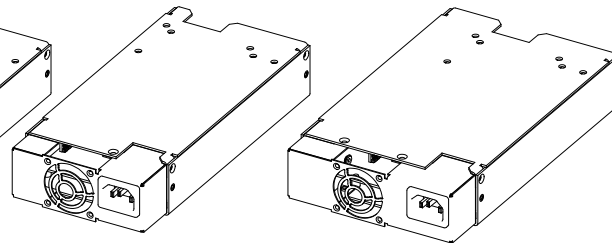

FAN+IEC OPTION

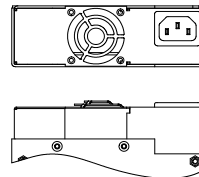
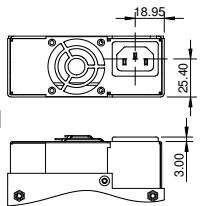

FAN OPTION

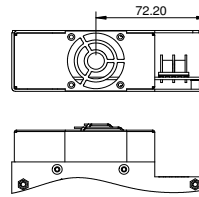
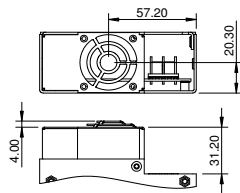

'U' CHANNEL

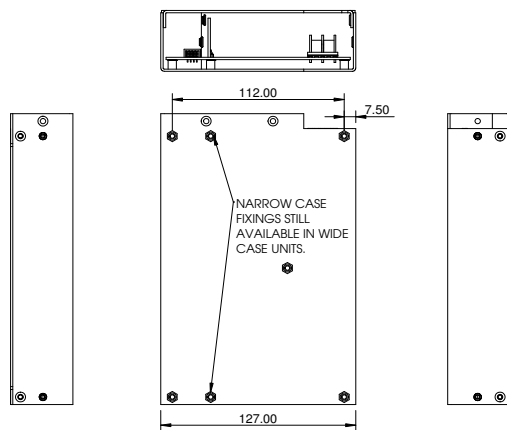
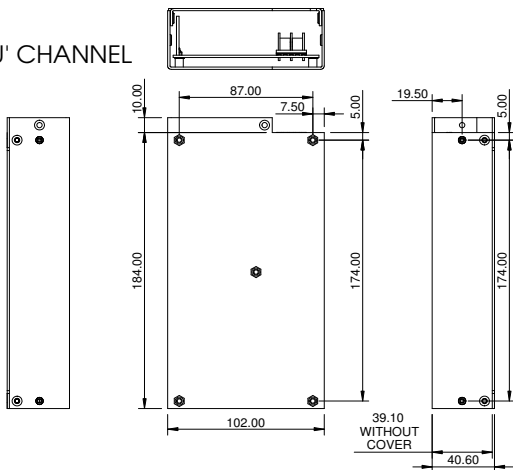

Notes 1. All customer fixings M3

2. Maximum Penetration 4.5mm

3. Maximum torque 0.9Nm

4. All tolerances +/-0.5mm



NV-350 / NV-700

350 - 1150Watts Modular power solution
With up to 1450W peak rating for 10 seconds

- High Efficiency
- High Power Density (up to 19W/in³)
- High Peak Power Rating
- Up to 8 outputs (6 for NV350)
- No minimum load
- Fits 1U applications
- Medical Approval
- 3 Year Warranty

Key Market Segments & Applications

Instrumentation	Broadcast
Medical	ATE
Automation	Industrial Computing
Security	Lifesciences/Laboratory
Network Servers and Routers	

Features and Benefits

Features

- High Efficiency
- Low Profile
- High Power Density

Benefits

- Minimises Heat in System
- Fits 1U Applications
- Less Space

NV350 / NV700 CONFIGURING

The extensive range of output modules and options make it possible to achieve almost any combination of Volts and Amps. You can create your own NV350 or NV700 configuration online at www.nv-power.com. This method checks your configuration and offers the optimum solution. Alternatively, you can do this manually by using the guide below.

1. Calculate total output power to ensure power requirements are within 350W or 1150W, then select required Cooling, Connection and Controls/Signals from the following table:

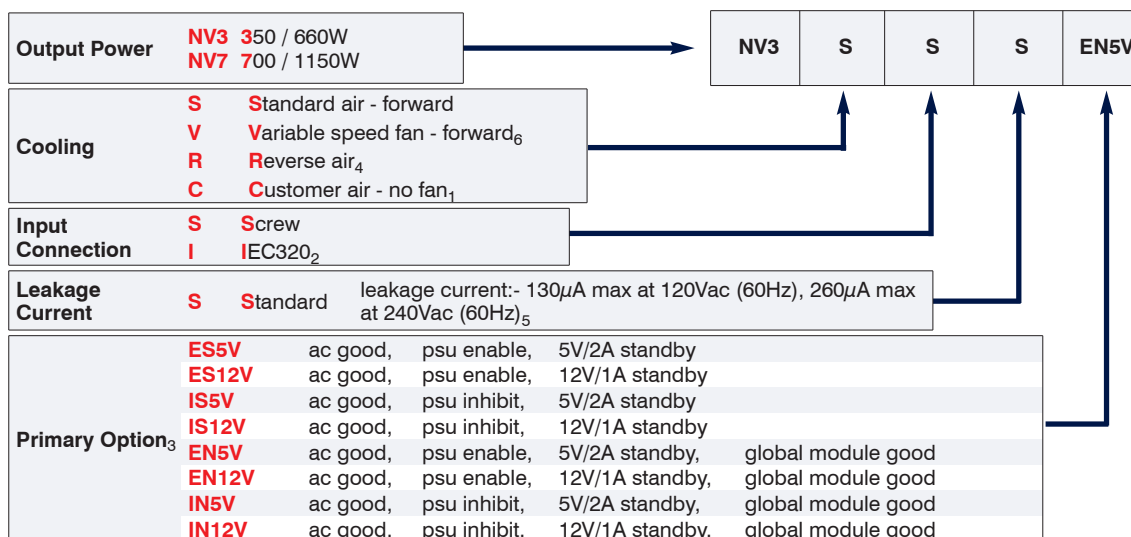

1 - Thermocoupled sample recommended to ensure adequate cooling - consult sales
2 - Not with customer air Cooling
3 - The Primary Option uses 1 slot
4 - Not with NV7
5 - Worst case leakage current is less than 300µA at 264Vac, 63Hz Normal Condition (<500µA Single Fault Condition)
6 - Recommended for new designs for NV-350. Not with NV7 (variable speed fan standard on NV7).



2. Select Output Modules from the Module Tables below ensuring that no more than 6 slots (NV-350) or 8 slots (NV-700) in total are used.

Example - if you require 13V 20A :-

- a) Select B as closest match for voltage & current and prefix with voltage eg **13BH**
- b) Repeat for other outputs.

This will create a complete product description eg **NV3SSSES5V 13BH 12/15DB** which represents a three output NV350 with Forward air cooling, Screw input terminals, standard leakage filter, ac good, PSU enable & 5V/2A aux supply

Output 1 = 13V / 20A. Output 2 = 12V / 13A with screw terminals. Output 3 = 15V / 4A with screw terminals
Max 350W continuous output power

3. Contact TDK-Lambda to validate configuration and issue a part number.

DUAL OUTPUT MODULES							
Module		Output 1		Output 2		Max Power	
Code	Slots	Voltage Range	Current	Voltage Range	Current		
DA	1 ₈	12 (fixed)		-12 (fixed)		1A	48W
DB	2	3.2 - 3.6	25A	3.3 - 5.5	10A	55W	
				7 - 15	5A	60W	
DB	2	4.75 - 5.5	25A	24 - 32	2A	50W	
				3.3 - 5.5	10A	55W	
DB	2	5.5 - 6.5	25A	7 - 15	5A	60W	
				24 - 32	2A	50W	
DB	2	12 - 15	13A ₁	3.3 - 5.5	10A	55W	
				7 - 15	5A	60W	
DB	2	24 - 28	7A ₂	24 - 32	2A	50W	
				3.3 - 5.5	10A	55W	
DB	2	24 - 28	7A ₂	7 - 15	5A	60W	
				24 - 32	2A	50W	

1. derate linearly from 13A at 12.5V to 10A at 15.5V
2. derate linearly from 7A at 25V to 6A at 28V
3. for NV3 - derate linearly from 40A at 5.2V to 36A at 5.5V
for NV7 - derate linearly from 40A at 5V to 36A at 5.5V
4. derate linearly from 22.5A at 8V to 20A at 9V
5. for NV3 - derate linearly from 20A at 13.2V to 16.5A at 15.5V
for NV7 - derate linearly from 20A at 12.5V to 15.5A at 15.5V

SINGLE OUTPUT MODULES						
Module		Voltage Range		Current		
Code	Slots			Continuous	Peak	
B	2	3.2 - 3.6		40A	40A	
		4.75 - 5.5		40A ₃	40A ₃	
		7 - 9		22.5A ₄	22.5A ₄	
BH	2	12 - 15.5		20A ₅	20A ₅	
		24 - 28		10A ₆	10A ₆	
C	3	12 - 13.2		37.5A ₇	50A ₇	
		15 - 16.5		30A ₇	37.5A ₇	
		24 - 26.4		18.75A ₇	25A ₇	
		27 - 32		16.6A ₇	19.7A ₇	
CM	3	24 - 26.4		18.75A ₇	25A ₇	
		24 - 26.4		37.5A ₉	50A ₉	
CC	6	30 - 33		30A ₉	37.5A ₉	
		48 - 52.8		18.75A ₉	25A ₉	
		54 - 63		16.6A ₉	19.7A ₉	
CCM	6	48 - 52.8		18.75A ₉	25A ₉	

6. for NV3 - derate linearly from 10A at 25.7V to 8.5A at 28V
for NV7 - derate linearly from 10A at 24V to 8.5A at 28V
7. for NV3, 400W max
for NV7, 600W peak for up to 10sec, 450W average
8. Only one per power supply.
9. for NV7 only, 1200W peak for up to 10sec, 900W average

INPUT				
Input Voltage	90-264Vac		Input Frequency	47 - 63 Hz (up to 440Hz with reduced PFC)
Input Harmonics	EN61000-3-2 compliant		Power Factor	0.97 typical
Inrush Current	NV-350 <15A	at 25°C and 264Vac	Input Fuse	NV-350 6.3A 250Vac HBC Fast Acting
	NV-700 <40A	(cold start)		NV-700 16A (not user accessible)
Leakage Current	130µA max at 120Vac (60Hz), 260µA max at 240Vac (60Hz) Worst case leakage current is less than 300µA at 264Vac, 63Hz (Normal Condition, <500µA Single Fault Condition)			

OUTPUT POWER						
		90-115Vac	115-150Vac	150-180Vac	180-264Vac	Comments
NV-350	Continuous ₆	350W	450W	450W	660W	1. 350W average 2. 450W average 3. 600W average 4. 700W average 5. 1150W average 6. 250W for reverse air 7. Not for reverse air
	Peak (10s) ₇	400W ₁	500W ₂	500W ₂	740W ₃	
NV-700	Continuous	700W	700W	1150W	1150W	
	Peak (10s)		850W ₄	1150W	1450W ₅	

OUTPUT		
Voltage / Current	See module tables	
Turn on Time	1.5s max	at 90Vac and 100% rated output power
Rise time	<50ms	to 90% of voltage, monotonic rise above 10%
Efficiency	up to 90%	configuration dependent
Hold up	16ms min	at 90Vac and 100% rated power (12ms for NV-700 above 700W output power)
Ripple and Noise	<1%	pk-pk, using EIAJ test method & 20MHz bandwidth
Voltage Accuracy	<1%	of set voltage (DA module: +5/-1% for channel 1, +2/-3.5% for channel 2)
Remote Sense	Yes	standard on single o/p + ch1 of dual modules, max 0.5V total line drop (DA module: None)
Minimum Load	No	on any output (DA module: 150mA on channel 1)
Temperature Coefficient	<0.02%	of rated voltage per °C
Load Regulation	<1%	for 0-100% load change (<2% for channel 2) (DA module: <3%)
Line Regulation	<0.1%	for 90-264Vac input change
Cross Regulation	<0.1%	for 100% load change on any output (DA module: 0.2% for channel 1, 3% for channel 2)



OUTPUT - continued		
Transient Response	<4%	of set voltage for 50% load change
Recovery	500µs	for recovery to 1% of set voltage (DA module: 1000µs)
Over Voltage Protection	Yes	
Over Current Protection (singles)	110 - 150%	of module current. Hiccup mode. Module primary side protected
Power Limit (duals)	110 - 150%	of max Power ch1 + ch2. Hiccup mode. Module primary side protected (DA module: 110-220% for channel 1, 110 - 170% for channel 2)
Short Circuit Protection	Yes	
Over Temperature Protection	Yes	cycle ac off/on to reset Shutdown temperature varies according to ambient, output power & input Voltage.

ISOLATION			
Input to Output	Reinforced	4kV (ac), 5.7kV (dc) type tested to 4kVac (equivalent to 5.7kVdc), production tested to 4.3kVdc	Outputs from C, CC, CM or CCM modules only
	Reinforced	4.3kV (dc) Note: Basic for IEC/EN/UL/CSA60601-1	Units with any other module or primary option
Input to Earth	Basic	2.3kV (dc)	
Output to Earth		200V (dc).	CM and CCM modules are 500Vac

SIGNALS - Standard	
Ch1/Ch2 Module Good	Open collector output. 'On' indicates output is within 90% (±5%) of nominal
Module Inhibit	TTL logic high inhibits the output (both outputs for duals) of the module
Ch2 On/Off (duals only)	TTL logic low inhibits output 2 of the module
All signals referenced to 0V of channel	

GLOBAL INTERFACE SIGNALS - with Primary Option	
AC good collector AC good emitter	Uncommitted optocoupler. Turns on typically 5ms after ac is good and off typically 5ms before any channel falls below 95% of nominal
Global module good collector Global module good emitter	Uncommitted optocoupler. Turns on typically 200ms after all outputs are within 90% (±5%) of nominal and off typically 5ms before any channel falls below 90% (±5%) of nominal. Do not connect for ES and IS type primary option.
EN/ES & IN/IS Logic 0	TTL low enables (EN or ES) or inhibits (IN or IS) the entire psu including fan (except standby)
EN/ES & IN/IS Logic 1	TTL high enables (EN or ES) or inhibits (IN or IS) the entire psu including fan (except standby)
Standby Supply	5V / 2A (2.5A peak) or 12V / 1A (1.2A peak)

ENVIRONMENT	
Temperature	0° to 50° operational, -40° to 85°C storage (max 12 months)
Derating	50°C _a to 70°C derate total output power and each output current by 2.5% per °C
Low Temperature Start-up	-20°C
Humidity	5-95% RH non condensing
Shock	±3 x 30g shocks in each plane, total 18 shocks 30g shock = 11ms (±0.5ms), half sine conforms to EN60068-2-27, EN60068-2-47, IEC68-2-27, IEC68-2-47, JIS C0041-1987.
Vibration	Single axis 10 - 500Hz at 2g (sweep and endurance at resonance) in all 3 planes
Altitude	3,000 metres operational (5,000 metres non operational)
Pollution	Degree 2, Material group IIIb
a - 45°C for NV7 with input voltage below 100Vac	

IMMUNITY EN61000-6-2:2005, EN60601-1-2:2001				Criteria
Electrostatic Discharge	EN61000-4-2	Level 4	Air discharge 15kV Contact discharge 8kV	A
Electromagnetic Field	EN61000-4-3	Level 3	12V/m	A
Fast / Burst Transient (ac input)	EN61000-4-4	Level 4	tested to 4.4kV	A
Fast / Burst Transient (dc output)	EN61000-4-4	Level 4	tested to 2.2kV	A
Surge Immunity	EN61000-4-5	Level 3	Common mode - 2.2kV Differential - 1.1kV	A
Conducted RF Immunity	EN61000-4-6	Level 3	12V	A
Power Frequency Magnetic Field	EN61000-4-8	Level 4	30A/m	A
Voltage Dips, Variations, Interruptions	EN61000-4-11	Class 3	Criteria B for 5 sec interruption	A
Voltage Fluctuations	EN61000-4-14	Class 3	For 100 - 240V Nominal	A



EMISSIONS EN61000-6-3:2001, EN60601-1-2:2001

Radiated Electric Field	EN55011, EN55022	(as per CISPR.11/22) Class B, FCC47 part 15 subpart B see app note for details
Conducted Emissions	EN55011, EN55022	(as per CISPR.11/22) Class B, FCC47 part 15 subpart B
Conducted Harmonics	EN61000-3-2	Class A
Flicker	EN61000-3-3	Compliant - d _{max} only

SAFETY APPROVALS

	Date	Amendments	Date	Amendments	
EN 60950-1	2006		EN 61010-1	2001	
UL 60950-1	2003		IEC 61010-1*	2001	
CSA22.2 No 60950-1	2003		IEC 60601-1*	1988	A1, A2
IEC 60950-1*	2005		EN 60601-1	1990	A1, A2, A13
CE Mark	LV Directive 2006/95/EC (EN60950-1)		UL 60601-1	2003	with revisions 2006

* CB Certificate and report available on request Please check with Technical Sales for status of approvals

PRIMARY OPTION / DA MODULE

DA Module

- 1 +12V (channel 1)
- 2 +12V (channel 1)
- 3 +12V (channel 1)
- 4 0V (common ch1 / ch2)
- 5 0V (common ch1 / ch2)
- 6 0V (common ch1 / ch2)
- 7 -12V (channel 2)
- 8 -12V (channel 2)

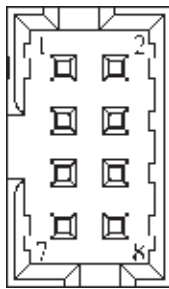

Primary Option

- 1 +V Standby
- 2 0V Standby
- 3 EN/ES & IN/IS Logic 1
- 4 EN/ES & IN/IS Logic 0
- 5 Global Module Good Collector
- 6 Global Module Good Emitter
- 7 AC good Collector
- 8 AC good Emitter

Housing: Molex 51110-0860
Crimp pin: 50394
Hand crimp tool: 69008-0959

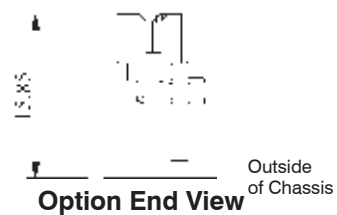

OUTPUT CONNECTIONS

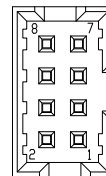
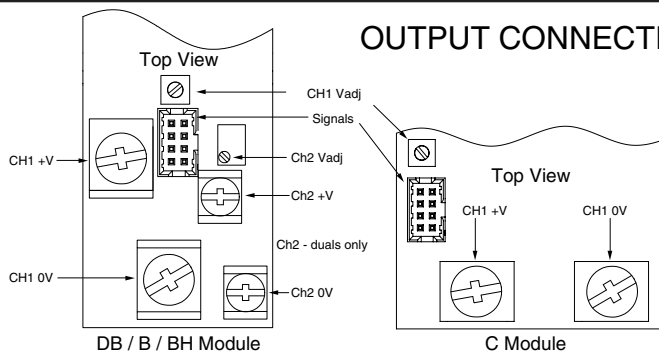

- Signals
- 1 Ch2 0V
 - 2 Ch2 Output Good
 - 3 Ch2 On/Off
 - 4 Module Inhibit
 - 5 Ch1 0V
 - 6 Ch1 Output Good
 - 7 Ch1 Remote Sense -
 - 8 Ch1 Remote Sense +

Housing: Molex 51110-0860
Crimp pin: 50394 Hand crimp tool: 69008-0959
Note: Do not connect pins 1-3 on single output modules

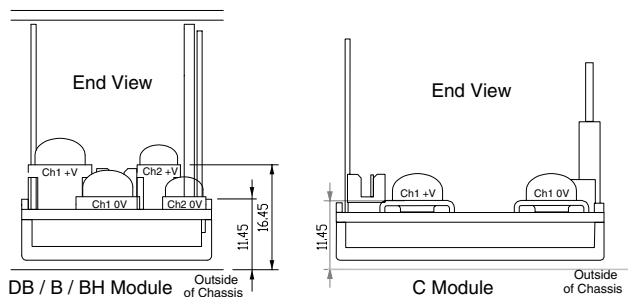

Connection Guidelines
Ring Tags: Up to 50A, AMP PIDG terminals
Red: M3 36151, M4 320551, M5 130660
Blue: M3 320561, M4 320560, M5 130663
Yellow: M3 M4 320568, M5 130167
Crimp tool: 16900 Die set 169404

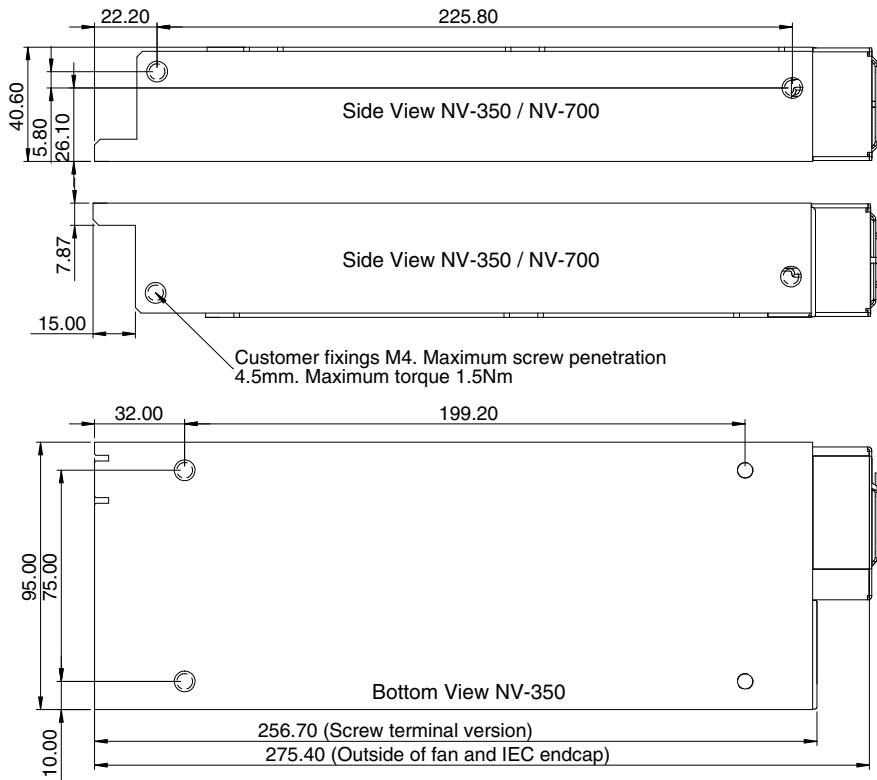

NOTES

- 1) Dimensions in mm
- 2) Tolerances:
Edge to edge/Edge to centre, +/-0.5
Centre to centre +/-0.2

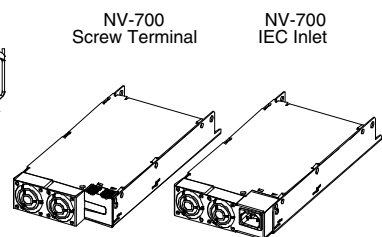
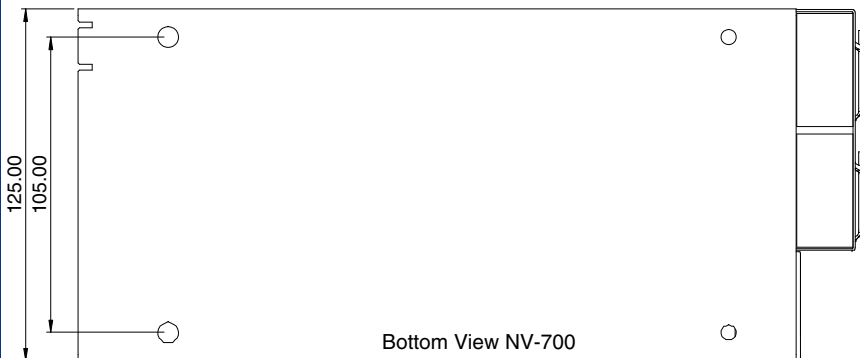
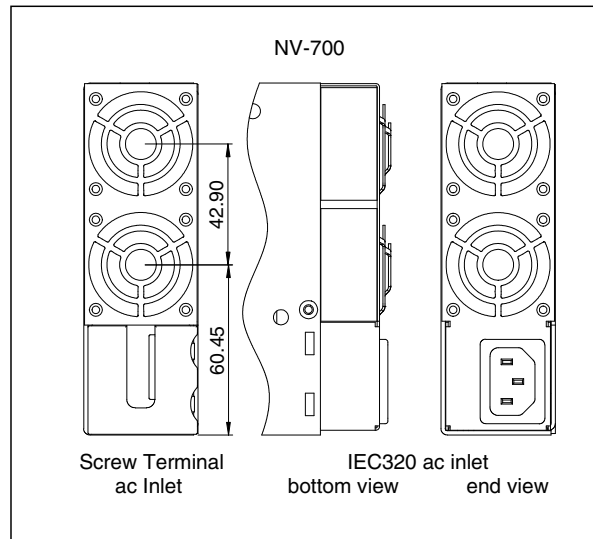
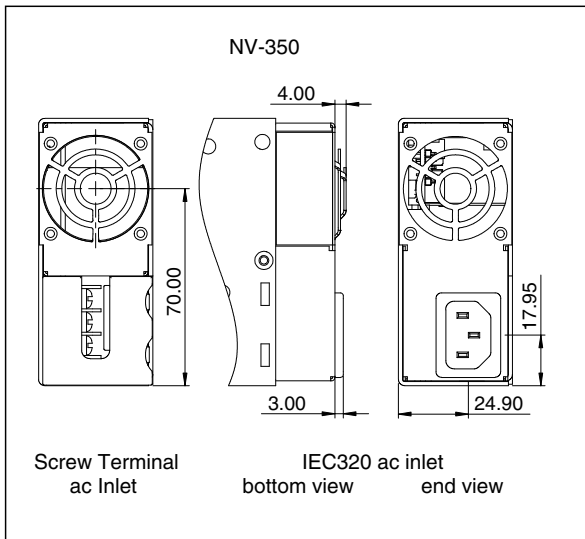
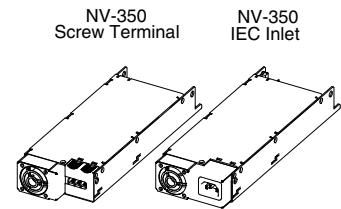



Vega Series

450, 650 & 900 Watts
Modular Power Solution

- Industry Leading Flexibility
- Up to 11 outputs
- Voltages up to 62V, Current up to 114 Amps
- Screw, Fast-on or IEC connection
- Worldwide approvals & CB report
- Medical Approval Option
- 3 Year Warranty

Key Market Segments & Applications

Instrumentation	Broadcast
Medical	ATE
Automation	Industrial Computing
Security	Lifesciences/Laboratory
Network Servers and Routers	

Features and Benefits

Features

- Modular construction
- Selection of termination options
- Worldwide Safety Approvals

Benefits

- Maximum flexibility
- Improves connection / looming options
- Supports global use

INPUT

	Vega 450, 650, and 900	Vega dc (450W)
Input Voltage	90 - 264Vac 900W version is 150-264Vac only, 650W below 150Vac	34 - 75Vdc Derate linearly below 44V to 340W at 34V
Input Frequency	47 - 63Hz (440Hz with reduced PFC - consult factory)	dc only
Inrush Current	<40A at 25°C and 264Vac (cold start)	<40A at 25°C, ETSI EN300 132-2
Input Fuse	16A / 250Vac HBC Fast Acting (not user accessible)	20A Fast Acting (not user accessible)
Leakage Current	1.5mA max at 264Vac & 63Hz	n/a
Lower Leakage Option	see configuring guide	n/a
Power Factor	0.99 typical	n/a

OUTPUT

Voltage / Current	See module output table	
Turn on Delay	1.5s max	at 90Vac (150Vac for 900W, 48Vdc for Vega dc) & 100% rated output power
Rise Time	<50ms	to 90% of voltage, monotonic rise above 10%
Turn on Overshoot	<5% or 250mV	Load type dependant, no overshoot with resistive load
Efficiency	75%	typical at 230Vac (48Vdc for Vega dc) & 100% rated power, config dependent
Hold up	16ms min	at 90Vac (150Vac for 900W) & 100% rated output power. 10ms min for Vega dc
Ripple & Noise	<1% or 50mV	Pk- Pk, using EIAJ test method & 20MHz bandwidth
Voltage Accuracy	<1%	of set Voltage
Remote Sense	Yes	Standard on single output modules, max 0.75V total line drop Option for twin output modules
Minimum Load	No	on any output
Temperature Coefficient	<0.02%	of rated voltage per °C
Load Regulation	<0.5% or 25mV	for 0-100% load change
Line Regulation	<0.1%	for 90 - 264Vac input change (34-75Vdc for Vega dc)
Cross Regulation	<0.2%	for 100% load change on any other output
Transient Response Recovery	<6% or 300mV	of set voltage for 50% load change (above 25% load)
	500µs	for recovery to 1% or 100mV of set voltage
Over Voltage Protection	120 - 130%	of set voltage for outputs > 4.1V (Tracking OVP)
	140 - 150%	of set voltage for outputs < 4.1V (Tracking OVP)
	120 - 150%	of max rated output (Fixed OVP)
Over Current Protection	105 - 125%	of rated current, constant current characteristic
Short Circuit Protection	<150%	of rated current, when output voltage <1%
Over Temperature Protection	Yes	Shuts down all outputs and fan. Cycle ac off / on to reset

Note 1 shutdown temp varies according to ambient, output power and input V
2 ac fail signal (if fitted) provides 5ms warning of thermal shutdown



SAFETY APPROVALS

	Date	Amendments		Date	Amendments
EN 60950-1	2006		EN 61010-1	2001	
UL 60950-1	2003		IEC 61010-1*	2001	
CSA22.2 No 60950-1	2003		IEC 60601-1* _a	1988	A1, A2
IEC60950-1*	2005		EN 60601-1 _a	1990	A1, A2, A13
CE Mark	LV Directive 2006/95/EC (EN60950-1)		UL 60601-1 _a	2003	with revisions 2006
* CB Certificate and report available on request			a - Only for L, R and T leakage variants. Not applicable to Vega dc		

EMISSIONS BS EN61000-6-3:2001 (Residential, Commercial & Light Industrial Supply), also complies with BS EN61000-6-4:2001

Radiated Electric Field	EN55022	Class B (as per CISPR.22) Class A for Vega dc	See application note for details. Only for 'S' type leakage versions
Conducted Emissions	EN55022	Class B (as per CISPR.22) Class A for Vega dc	Only for 'S' type leakage versions. 'M' & 'L' types meet Class A
Conducted Harmonics	EN61000-3-2	Compliant to Class A	Not applicable to Vega dc
Flicker	EN61000-3-3	Compliant	Not applicable to Vega dc

IMMUNITY BS EN61000-6-2:2001 (Industrial Environment), also complies with BS EN61000-6-1:2001

				Criteria
Electrostatic Discharge	EN61000-4-2	Level 4	Air discharge 15kV Contact discharge 8kV	A
Electromagnetic Field	EN61000-4-3	Level 3	10V/m (tested to 12V/m)	A
Fast / Burst Transient	EN61000-4-4	Level 4 Level 3 for Vega dc	Input 4kV, (2kV for Vega dc) Outputs 2kV, (1kV for Vega dc) Tested at 5kHz and 100kHz	A
Surge Immunity	EN61000-4-5	Level 3 Level 2 for Vega dc	Line to Line 1kV tested to 1.1kV (0.5kV, tested to 0.55kV for Vega dc) Line to Earth 2kV tested to 2.2kV (1kV, tested to 1.1kV for Vega dc)	A
Conducted RF Immunity	EN61000-4-6	Level 3	10V (tested to 12V)	A
Power Frequency Magnetic Field	EN61000-4-8	Level 4	30A Continuous	A
Voltage Dips, Variation, Interruptions	EN61000-4-11	Class 3 na - Vega dc		A B for 5s interruptions

ENVIRONMENT

Temperature	0° to 65° operational, -40° to 85°C storage (max 12 months)
Derating	50°C to 65°C derate each output by 2.5% per °C (1.5% per °C for Vega dc)
Low Temperature Start-up	-20°C
Humidity	5-95% RH non condensing
Shock	±3 x 20g shocks in each plane, total 18 shocks 20g shock = 11ms (±0.5ms), half sine conforms to EN60068-2-27, EN60068-2-47, IEC68-2-27, IEC68-2-47, JIS C0041-1987 conforms to MIL-STD-810E/F, Method 516.5, Pro I, IV, VI
Vibration	Single axis 10 - 500Hz at 2g (sweep and endurance at resonance) in all 3 planes Conforms to EN60068-2-6, IEC68-2-6 Conforms to MIL-STD-810E, Method 514.4, Pro I, Cat 1, 9
Altitude	5000 metres operational / non operational (IEC inlet 3000m operational, 5000m non-operational)
Pollution	Degree 2, Material group 3
IP Rating	IP 10

ISOLATION

Input to Output	Reinforced	4kV (ac), 5.7kV (dc) type tested, production tested to 4.3kVdc. Vega dc = 4.3kVdc
Input to Earth	Basic	2.3 kV (dc) Output to Output / Output to Earth Operational 200 V (dc)



OUTPUT VOLTAGES (single output modules)					(twin output modules)							
Module	Adjustment Range (Volts)		Amps	Slots	Module	V1 Adjustment Range (Volts)		Amps	V2 Adjustment Range (Volts)	Amps	Slots	
B1L	1.8	- 3.8 _e	20	1	H1L/1L				1.8 - 3.8 _n	8	1	
C1	1.8	- 4.1 _e	35	1	H1L/1H				3.9 - 5.5 _d	8	1	
C1Y	1.8	- 4.1 _e	40	1	H1L/2	1.8	- 3.8 _n	12	5.6 - 9 _f	6	1	
D1L	1.8	- 3.8	50	1.5	H1L/3				9.1 - 16.2 _u	6	1	
E1	1.8	- 3.8 _e	60	2	H1L/4				16.3 - 25 _p	4.5	1	
F1 _a	1.8	- 3.8	80	2	H1H/1L				1.8 - 3.8 _n	8	1	
Z2	1.8	- 3.8 _e	95	3	H1H/1H				3.9 - 5.5 _d	8	1	
Z3	1.8	- 3.8 _e	114	4	H1H/2	3.9	- 5.5 _d	12	5.6 - 9 _f	6	1	
B1H	3.9	- 5.5 _d	20	1	H1H/3				9.1 - 16.2 _u	6	1	
L1	4.2	- 5.5 _d	35	1	H1H/4				16.3 - 25 _p	4.5	1	
D2	3.8	- 9 _k	45	1.5	H2/1L				1.8 - 3.8 _n	8	1	
D1H	3.9	- 5.5 _d	50	1.5	H2/1H				3.9 - 5.5 _d	8	1	
E2	3.8	- 8 _k	60	2	H2/2	5.6	- 9 _f	10	5.6 - 9 _f	6	1	
Z18	4.2	- 5.5	66	2	H2/3				9.1 - 16.2 _u	6	1	
F2 _a	3.8	- 8	75	2	H2/4				16.3 - 25 _p	4.5	1	
Z4	3.9	- 5.5 _d	95	3	H3/1L				1.8 - 3.8 _n	8	1	
Z6	3.9	- 5.5 _d	104	3.5	H3/1H				3.9 - 5.5 _d	8	1	
B2	5	- 9 _f	25	1	H3/2	9.1	- 16.2 _u	10	5.6 - 9 _f	6	1	
B3	9.1	- 16.2 _g	12	1	H3/3				9.1 - 16.2 _u	6	1	
C3	9.1	- 16.2 _g	18	1	H3/4				16.3 - 25 _p	4.5	1	
D3	8	- 16.5 _g	24	1.5	H5/1L				1.8 - 3.8 _n	8	1	
E3L	8	- 13.9 _l	40	2	H5/1H				3.9 - 5.5 _d	8	1	
Z7	8	- 16.5 _g	45	3	H5/2	16.2	- 28	5	5.6 - 9 _f	6	1	
EE2	7.6	- 16 _g	45	4	H5/3				9.1 - 16.2 _u	6	1	
D4	14	- 21.5 _i	18	1.5	H5/4				16.3 - 25 _p	4.5	1	
E4	14	- 19.9 _m	30	2	Wide Range Programmable Modules							
E3H	14	- 15	36	2	Module	Voltage Range	Amps	Slots				
C4	16.3	- 21.5 _i	14	1	W2 _a	1 - 7.5	30	1	Select features from table			
CC3	18.2	- 32.4 _j	18	2	W5	0.5 - 32	8.5	1	below			
E5L _v	20	- 24	27	2	Follow by	F or T Fixed or Tracking Overvoltage protection						
B5	21.6	- 31 _h	6	1		F or S Fast-on or Screw terminal						
C5	21.6	- 31 _j	10	1		R or V Resistance (0-32kOhm)						
D5	21	- 28	15	1.5		R or V Voltage (0-5V) programming						
E5H _v	24	- 28	25	2		1 Inhibit, Fixed Current Limit						
Z19 _{co}	24	- 28	36	3.5		1, 2, 3 Inhibit, Programmable current limit (0-5V)						
HH5/3	25.3	- 44.2 _b	5	1		or 4 3 Enable, Fixed Current Limit						
DD4	28	- 43 _s	18	3		4 Enable, Programmable current limit (0-5V)						
EE4 _c	28	- 38	22.5	4	Follow non wide range modules by F (Fast-on) or S (Screw) terminal							
HH5/4	32.5	- 53 _t	4.5	1	Options - Single output Modules*			Options - Twin Output Modules*				
BB4	32.6	- 43 _q	10	2	N	Output Inhibit, Module Good			Output Inhibit, Module Good, Remote Sense			
EE5L _{co}	40	- 48	18	4		Current Sharing			R Remote sense only			
C5B4	43	- 48	10	2	* see configuring guide							
EE5H _o	48	- 56	18	4								
CC5	48.1	- 62 _r	10	2								
DD5	42	- 56	15	3								

- a) F1, F2 and W2 modules not for Vega 900
- b) 38V max for 900W
- c) Only available for Vega 900
- d) 5.1V max for 900W
- e) 3.4V max for 900W
- f) 8V max for 900W
- g) 15V max for 900W
- h) 28V max for 900W

- i) 18V max for 900W
- j) 30V max for 900W
- k) 7.5V max for 900W
- l) 12.5V max for 900W
- m) 19V max for 900W
- n) 3.4V max for 900W
- o) 'N' option not available
- p) 24V max for 900W

- q) 40V max for 900W
- r) 60V max for 900W
- s) 36V max for 900W
- t) 52V max for 900W
- u) 15.5V max for 900W
- v) 'N' option not available if more than 1 module fitted



Vega Configuring Guide

The extensive range of output modules and options make it possible to achieve almost any combination of Volts and Amps. The 'online' configurator is the best way to achieve the optimum configuration, however you can also create your own Vega configuration from this datasheet by using the guide below.

Web Configurator

- 1 Visit <http://www.emea.tdk-lambda.com>, select 'Vega Configurator' and follow the online instructions.
- 2 Enter your required Volts / Amps, type of output connection and any additional functions (if required)
- 3 Enter preferred type of cooling, input connection, lower leakage current (if required) and controls & signal functions, (if required)
- 4 Configurator will select the most suitable modules and options and give a unique part number.

Configuring from Datasheet

- 1 Calculate total output power to determine Vega 450W, 650W or 900W and select converter, then select required Cooling, Connection, Leakage Current and Controls/Signals from the following table:-

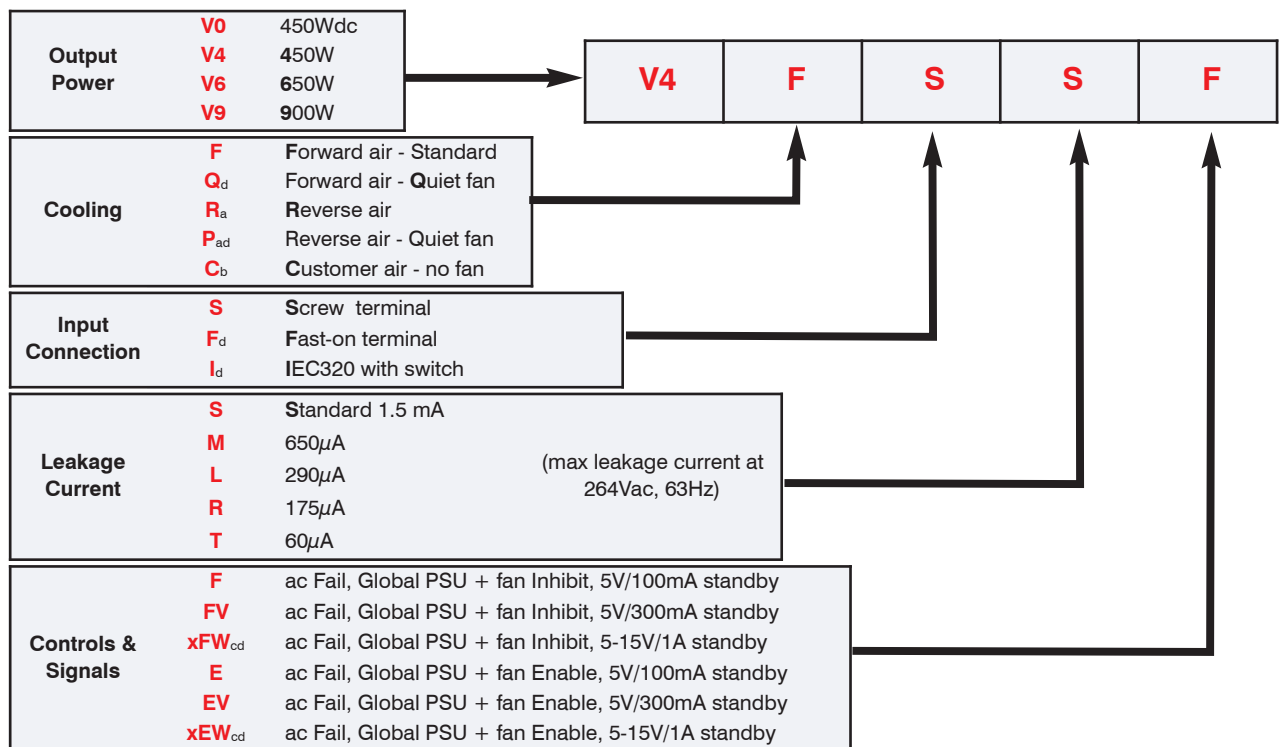

Notes:

- Not available for Vega 900
- Thermocoupled sample recommended to ensure adequate cooling - consult sales
- xFW and xEW options increase leakage current by 90µA
Replace 'x' with required output voltage (5FW = 5V aux supply)
- Not available for Vega dc.

- 2 Select Output Modules and Options from the Output Voltages tables.

Example - if you require 5.2V / 18A with output inhibit :-

- select B1H as closest match for voltage and current and prefix with voltage (eg **5.2B1H**)
- add suffix S or F for Screw or Fast-on connection (eg **5.2B1HS**)
- add suffix N for output inhibit eg **5.2B1HSN**
- repeat for other outputs

Ensure you do not select more than a total of 5 slots width of module. This will create a complete product description eg:-

V6FSSF 5L1SN 12/12H3/3S 24C5S which represents a four output 650W Vega with Forward air, Screw input terminals, 1.5mA Earth Leakage, ac Fail, Global Inhibit & 5V / 100mA aux supply with the following outputs:-

- Output 1 = 5V / 35A with output inhibit, Module Good and Current Share option
- Output 2 = 12V / 10A
- Output 3 = 12V / 6A
- Output 4 = 24V / 10A

- 3 Contact TDK-Lambda to validate configuration and issue a part number.

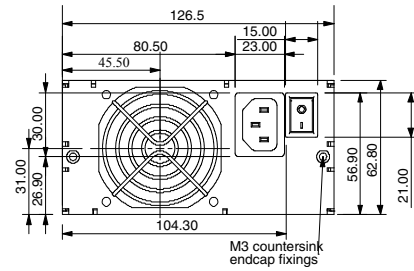
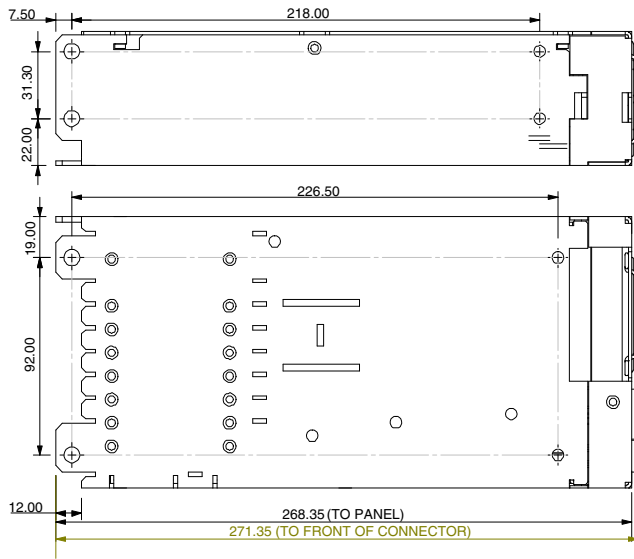

IEC-320 Connector Case

All versions have:-
 8 x M4 Customer fixings
 Max thread penetration:- 4.5mm

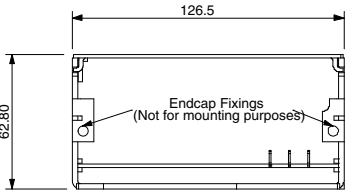
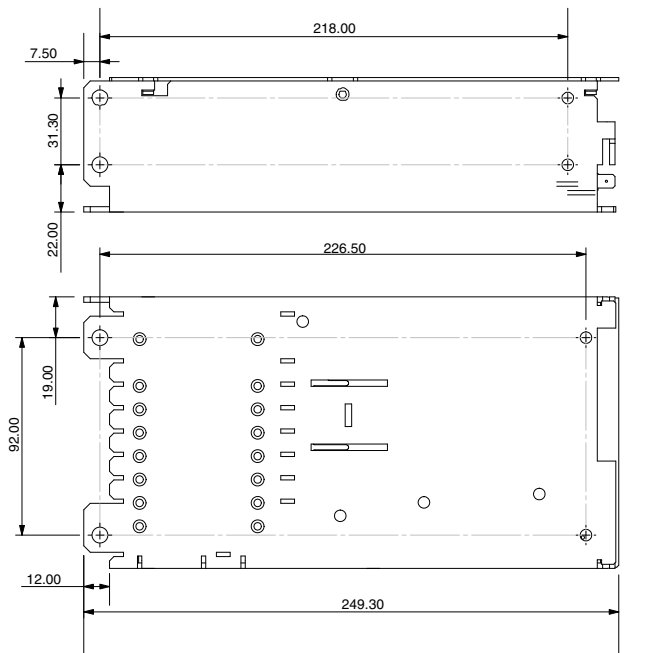

Customer Air Case (no fan)

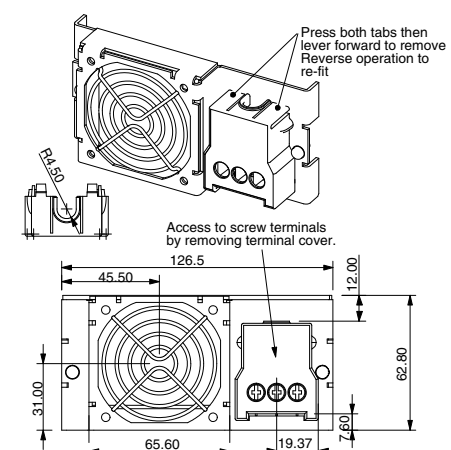
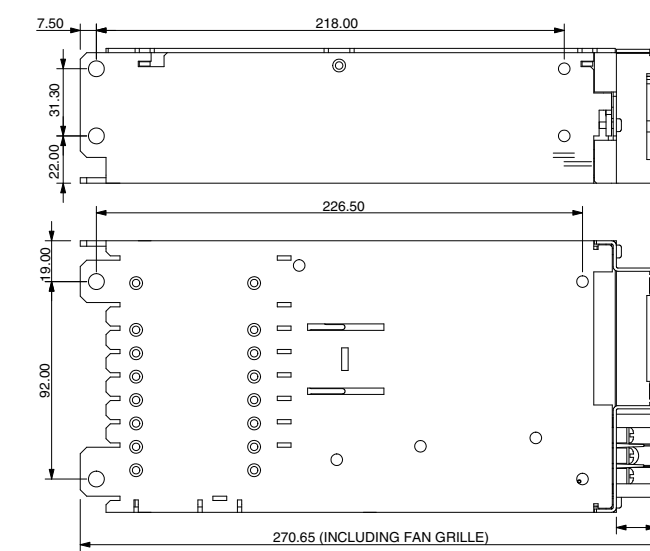

Screw & Fast-on Terminal Case

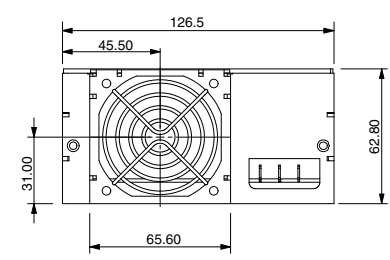



Vega-Lite Series

550 - 900 Watts

Modular power solution

- Industry Leading Flexibility
- 1 to 11 outputs
- Voltages from 1.8 to 56V
- Current up to 60 Amps
- Worldwide approvals & CB report
- Medical approval option
- 3 Year Warranty

Key Market Segments & Applications

Instrumentation	Broadcast
Medical	ATE
Automation	Industrial Computing
Security	Lifesciences/Laboratory
Network Servers and Routers	

Features and Benefits

Features

- Modular Construction
- Worldwide Safety Approvals

Benefits

- Maximum flexibility
- Supports Global use

INPUT

Voltage Range	85 - 264Vac
Frequency	47 - 63Hz (440Hz with reduced PFC - consult factory)
Inrush Current	<40A at 25°C and 264Vac (cold start)
Fuse	16A / 250Vac High Breaking Capacity, Fast Acting (not user accessible)
Leakage Current	1.5mA max at 264Vac & 63Hz (medical version also available)
Power Factor	0.99 typical

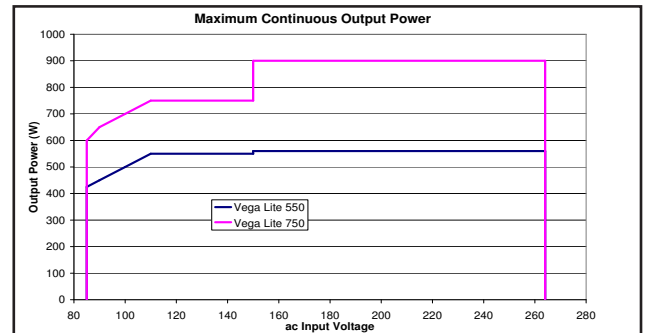

OUTPUT

Voltage / Current	See module tables	
Turn on Delay	1.5s max	at 90Vac & 100% rated output power
Rise Time	<50ms	to 90% of voltage, monotonic rise above 10%
Turn on Overshoot	<5% or 250mV	Load type dependant, no overshoot with resistive load
Efficiency	75%	typical at 230Vac & 100% rated power, configuration dependent
Hold up	16ms min	at 100Vac & 100% rated output power
Ripple & Noise	<1%	(or 50mV if higher) Pk- Pk, using EIAJ test method & 20MHz bandwidth
Voltage Accuracy	<1%	of set Voltage
Remote Sense	Yes	Standard on single output modules, max 0.75V total line drop Option for twin output modules
Minimum Load	No	on any output
Temperature Coefficient	<0.02%	of rated voltage per °C
Load Regulation	<0.5% or 25mV	for 0-100% load change
Line Regulation	<0.1%	for 100 - 264Vac input change
Cross Regulation	<0.2%	for 100% load change on any other output
Transient Response Recovery	<6% or 300mV	of set voltage for 50% load change (above 25% load)
	500µs	for recovery to 1% or 100mV of set voltage
Over Voltage Protection	120 - 130%	of set voltage for outputs > 4.1V (Tracking OVP)
	140 - 150%	of set voltage for outputs < 4.1V (Tracking OVP)
	120 - 150%	of max rated output (Fixed OVP)
Over Current Protection	105 - 125%	of rated current, constant current characteristic
Short Circuit Protection	<150%	of rated current, when output voltage <1%
Over Temperature Protection	Yes	Shuts down all outputs and fan. Cycle ac off / on to reset

Note 1 shutdown temp varies according to ambient, output power and input V
2 ac fail signal (if fitted) provides 5ms warning of thermal shutdown



OUTPUT VOLTAGES (single modules)								
Output Voltage	Module Width (Slots)							
	1 slot		1.5 slots		2 slots		3 slots	
	Module	Current	Module	Current	Module	Current	Module	Current
1.8V	1.8C1S	35A	1.8D1LS	50A	1.8E1S	60A		
2V	2C1S	35A	2D1LS	50A	2E1S	60A		
3.3V	3.3C1S	35A	3.3D1LS	50A	3.3E1S	60A		
5V	5L1S	35A	5D1HS	50A	5E2S	60A		
6.5V	6.5B2S	25A	6.5D2S	45A	6.5E2S	60A		
12V	12C3S	18A	12D3S	24A	12E3LS	40A		
15V	15C3S	18A	15D3S	24A	15E4S	30A		
18V	18C4S	14A	18D4S	18A	18E4S	30A		
24V	24C5S	10A	24D5S	15A	24E5HS	25A		
28V	28C5S	10A	28D5S	15A	28E5HS	25A		
36V	36HH5/4S	4.5A			36BB4S	10A		
48V	48HH5/4S	4.5A			48C5B4S	10A	48DD5S	15A

OUTPUT VOLTAGES (twin modules) - all 1 slot width							
Output Voltage	Channel 1						
	5V / 12A	12V / 10A	15V / 10A	18V / 5A	24V / 5A	28V / 5A	
Channel 2	1.8V / 8A	5/1.8H1H/1LS					
	2V / 8A	5/2H1H/1LS					
	3.3V / 8A	5/3.3H1H/1LS					
	5V / 8A		12/5H3/1HS	15/5H3/1HS	18/5H5/1HS	24/5H5/1HS	28/5H5/1HS
	12V / 6A	5/12H1H/3S	12/12H3/3S	15/12H3/3S	18/12H5/3S	25/12H5/3S	28/12H5/3S
	15V / 6A	5/15H1H/3S	12/15H3/3S	15/15H3/3S	18/15H5/3S	25/15H5/3S	28/15H5/3S
	18V / 4.5A				18/18H5/4S	24/18H5/4S	28/18H5/4S
	24V / 4.5A				18/24H5/4S	24/24H5/4S	28/24H5/4S

OUTPUT VOLTAGES (single modules)						TWIN OUTPUT MODULES							
Module	Adjustment Range (Volts)		Amps	Slots		Module	V1 Adjustment Range (Volts)		Amps	V2 Adjustment Range (Volts)		Amps	Slots
C1S	1.8	- 3.4	35	1		H1H/1LS	3.9	- 5.1	12	1.8	- 3.4	8	1
D1LS	1.8	- 3.8	50	1.5		H1H/3S	3.9	- 5.1	12	9.1	- 15.5	6	1
E1S	1.8	- 3.4	60	2		H3/1HS	9.1	- 15.5	10	3.9	- 5.1	8	1
L1S	4.2	- 5.1	35	1		H3/3S	9.1	- 15.5	10	9.1	- 15.5	6	1
D2S	3.8	- 7.5	45	1.5		H5/1HS	16.2	- 28	5	3.9	- 5.1	8	1
D1HS	3.9	- 5.1	50	1.5		H5/3S	16.2	- 28	5	9.1	- 15.5	6	1
E2S	3.8	- 7.5	60	2		H5/4S	16.2	- 28	5	16.3	- 24	4.5	1
B2S	5	- 8	25	1									
C3S	9.1	- 15	18	1									
D3S	8	- 15	24	1.5									
E3LS	8	- 12.5	40	2									
D4S	14	- 18	18	1.5									
E4S	14	- 19	30	2									
C4S	16.3	- 21.5	14	1									
C5S	21.6	- 30	10	1									
D5S	21	- 28	15	1.5									
E5HS	24	- 28	25	2		Options - Single output Modules*				Options - Twin Output Modules*			
HH5/4S	32.5	- 48	4.5	1		N	Output Inhibit, Module Good Current Sharing			N Output Inhibit, Module Good, Remote Sense			
BB4S	32.6	- 40	10	2	R Remote Sense Only								
C5B4S	43	- 48	10	2									
DD5S	42	- 56	15	3		* see configuring guide							



SAFETY APPROVALS					
	Date	Amendments		Date	Amendments
EN 60950-1	2006		EN 61010-1	2001	
UL 60950-1	2003		IEC 61010-1*	2001	
CSA22.2 No 60950-1	2003		IEC 60601-1*	1988	A1, A2
IEC 60950-1*	2005		EN 60601-1 _a	1990	A1, A2, A13
CE Mark	LV Directive 2006/95/EC (EN60950-1)		UL 60601-1 _a	2003	with revisions 2006
* CB Certificate and report available on request			a - Only for 'L' type leakage variants Check with technical Sales for status of approvals		

ISOLATION					
Input to Output	Reinforced	4kV (ac), 5.7kV (dc) type tested, production tested to 4.3kVdc.			
Input to Earth	Basic	2.3 kV (dc)	Output to Output / Output to Earth	Operational	200 V (dc)

EMISSIONS BS EN61000-6-3:2001 (Residential, Commercial & Light Industrial Supply), also complies with BS EN61000-6-4:2001			
Radiated Electric Field	EN55022	Class B (as per CISPR.22)	See application note for details. Only for 'S' type leakage versions
Conducted Emissions	EN55022	Class B (as per CISPR.22)	Only for 'S' type leakage versions. 'L' types meet Class A
Conducted Harmonics	EN61000-3-2	Compliant to Class A	
Flicker	EN61000-3-3	Compliant	

IMMUNITY BS EN61000-6-2:2001 (Industrial Environment), also complies with BS EN61000-6-1:2001					Criteria
Electrostatic Discharge	EN61000-4-2	Level 4	Air discharge 15kV Contact discharge 8kV		A
Electromagnetic Field	EN61000-4-3	Level 3	10V/m (tested to 12V/m)		A
Fast / Burst Transient	EN61000-4-4	Level 4	Input 4kV Outputs 2kV Tested at 5kHz and 100kHz		A
Surge Immunity	EN61000-4-5	Level 3	Line to Line 1kV (tested to 1.1kV) Line to Earth 2kV (tested to 2.2kV)		A
Conducted RF Immunity	EN61000-4-6	Level 3	10V (tested to 12V)		A
Power Frequency Magnetic Field	EN61000-4-8	Level 4	30A Continuous		A
Voltage Dips, Variation, Interruptions	EN61000-4-11	Class 3			A B for 5s interruptions

ENVIRONMENT	
Temperature	0° to 65° operational, -40° to 85°C storage (max 12 months)
Derating	50°C to 65°C derate each output by 2.5% per °C
Low Temperature Start-up	-20°C
Humidity	5-95% RH non condensing
Shock	±3 x 20g shocks in each plane, total 18 shocks 20g shock = 11ms (±0.5ms), half sine conforms to EN60068-2-27, EN60068-2-47, IEC68-2-27, IEC68-2-47, JIS C0041-1987 conforms to MIL-STD-810E/F, Method 516.5, Pro I, IV, VI
Vibration	Single axis 10 - 500Hz at 2g (sweep and endurance at resonance) in all 3 planes Conforms to EN60068-2-6, IEC68-2-6 Conforms to MIL-STD-810E, Method 514.4, Pro I, Cat 1, 9
Altitude	5,000 metres operational / non operational
Pollution	Degree 2, Material group 3
IP Rating	IP 10



Vega-Lite Configuring Guide

The extensive range of output modules and options make it possible to achieve all popular combinations of Volts and Amps. The 'online' configurator is the best way to achieve the optimum configuration, however you can also create your own Vega configuration from this datasheet by using the guide below.

Web Configurator

- 1 Visit <http://www.emea.tdk-lambda.com>, select 'Vega Configurator' and follow the online instructions.
- 2 Enter your required Volts / Amps, and any additional functions (if required)
- 3 Enter preferred type of cooling, input connection, lower leakage current (if required) and controls & signal functions, (if required)
- 4 Configurator will select the most suitable modules and options and give a unique part number.

Configuring from Datasheet

1 Calculate total output power to determine Vega 550W (560W at 150 Vac and above) or 750W (900W at 150Vac and above) and select converter, then select required Cooling, Connection, Leakage Current and Controls/Signals from the following table:-

2 Select Output Modules and Options from the Available Output Voltages tables.

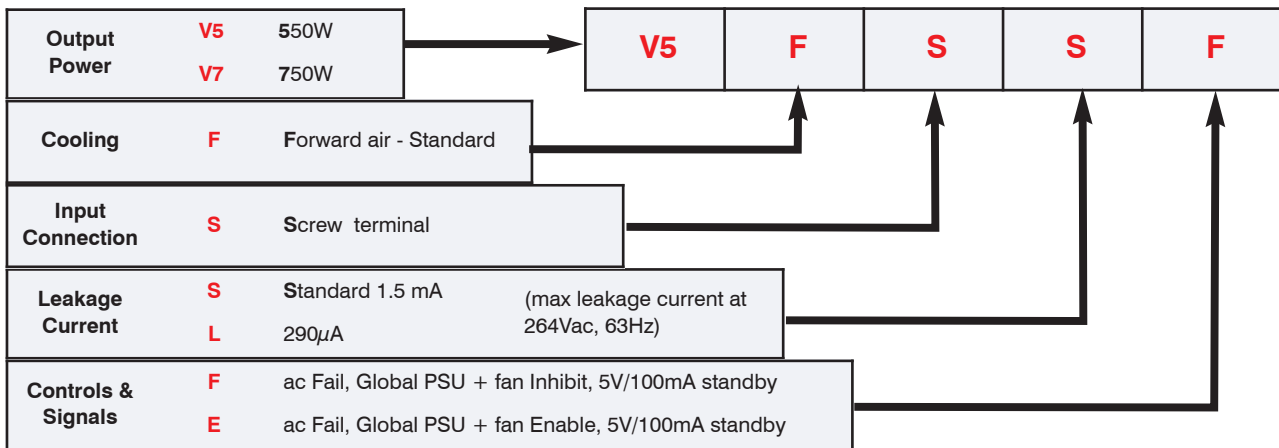

- Example - if you require 5V / 18A with output inhibit :-
- a) select 5L1S as closest match for voltage and current
 - b) add suffix N for output inhibit eg **5L1SN**
 - c) repeat for other outputs

Ensure you do not select more than a total of 5 slots width of module. This will create a complete product description eg:- **V5FSSF 5L1SN 12/12H3/3S 24C5S** which represents a four output 550W Vega with Forward air, Screw input terminals, 1.5mA Earth Leakage, ac Fail, Global Inhibit & 5V / 100mA aux supply.

- Output 1 = 5V / 35A with output inhibit, Module Good and Current Share option
- Output 2 = 12V / 10A
- Output 3 = 12V / 6A
- Output 4 = 24V / 10A

3 **Contact TDK-Lambda to validate configuration and issue a part number.**

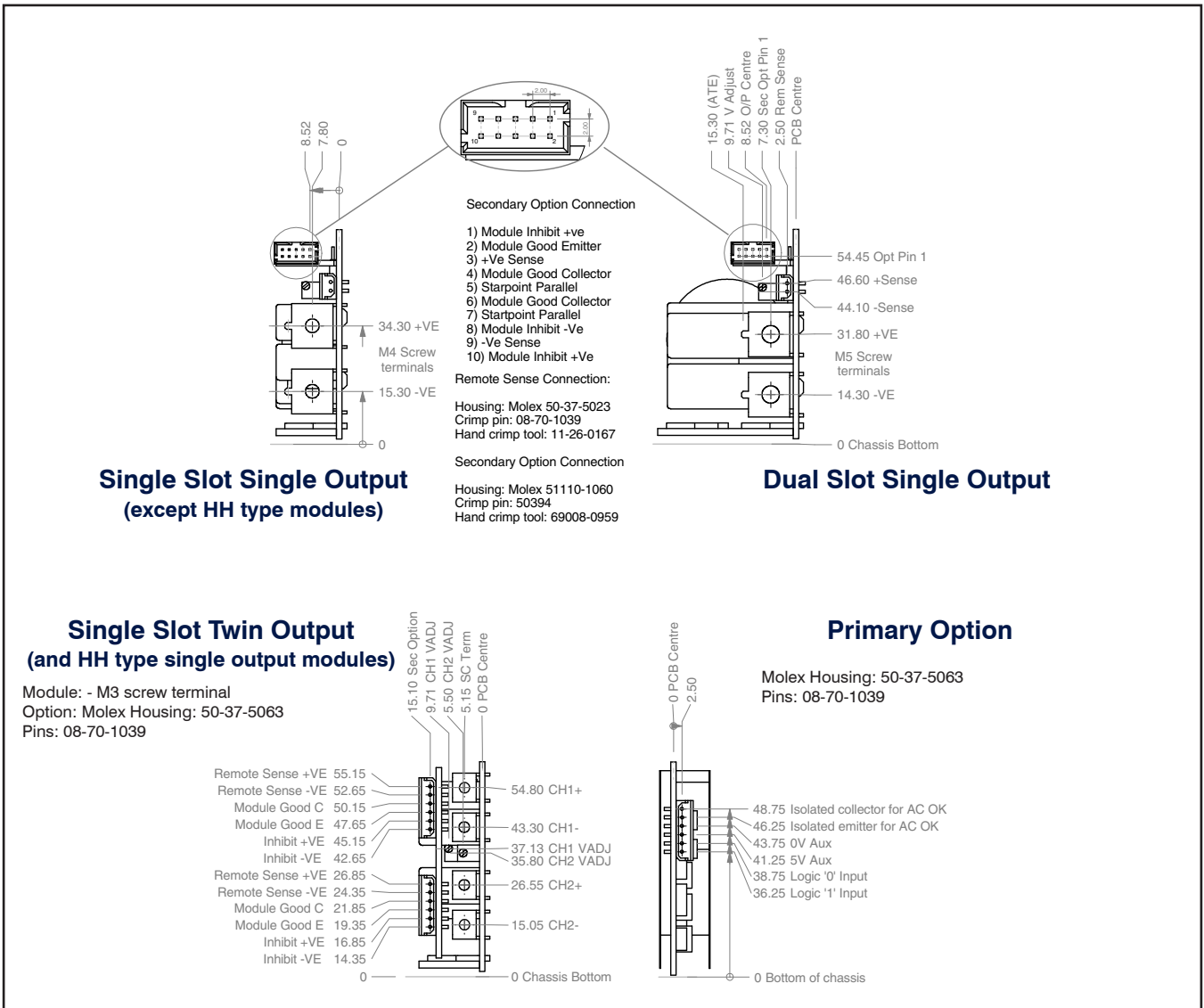
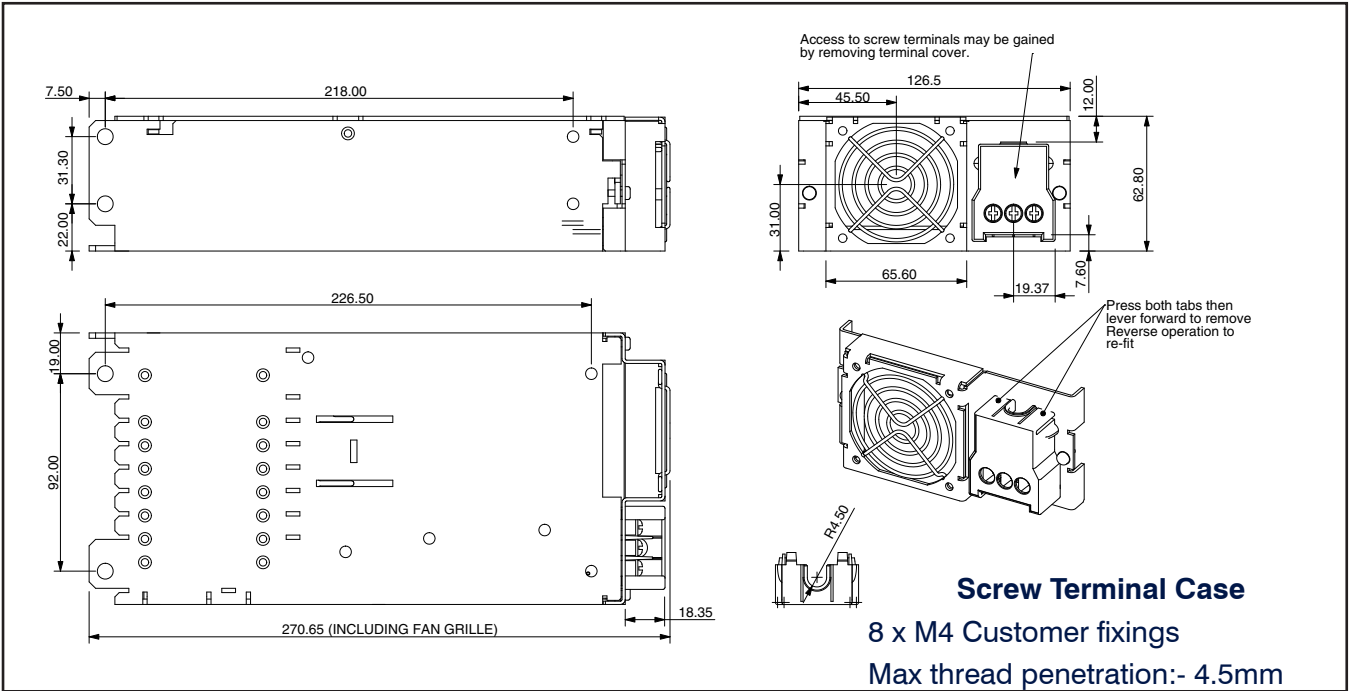



Alpha Series

1000 and 1500W
AC/DC Modular

- Up to 16 outputs
- Voltages up to 48V, Current up to 300A
- Fast-on output connection
- Worldwide approvals & CB report
- Medical Approval Option
- 3 Year Warranty

Key Market Segments & Applications

Instrumentation	Broadcast
Medical	ATE
Automation	Industrial Computing
Security	Lifesciences/Laboratory
Network Servers and Routers	

Features and Benefits

Features

- Low Profile
- Fast-on output terminal
- Medical Approval available

Benefits

- Simpler to install in system
- Reduces installation time/errors
- Suitable in medical applications

INPUT

Input Voltage	Alpha 1000	85 - 264Vac, 120 - 360Vdc
	Alpha 1500	85 - 264Vac (1000W below 150Vac input)
Input Frequency	47 - 63Hz (440Hz with reduced PFC - consult factory)	
Inrush Current	<50A at 25°C and 264Vac (cold start)	
Input Fuse	20A / 250Vac HBC Fast Acting (not user accessible)	
Leakage Current	1.1mA max at 264Vac & 63Hz	
Lower Leakage Option	see configuring guide	
Power Factor	0.99 typical	

OUTPUT

Voltage / Current	See module output table	
Turn on Delay	1.5s max	at 90Vac (150Vac for Alpha 1500W) & 100% rated output power
Rise Time	<50ms	to 90% of voltage, monotonic rise above 10%
Turn on Overshoot	<5% or 250mV	Load type dependant, no overshoot with resistive load
Efficiency	75%	typical at 230Vac & 100% rated power, config dependent
Hold up	13ms min	at 90Vac & 100% rated output power 13ms for 1000W, 8ms for 1500W and at 207Vac for 1500W
Ripple & Noise	<2%	(or 100mV if greater) Pk- Pk, using EIAJ test method & 20MHz bandwidth
Voltage Accuracy	<1%	of set Voltage
Remote Sense	Yes	Standard on single output modules
Minimum Load	No	on any output
Temperature Coefficient	<0.02%	of rated voltage per °C
Load Regulation	<0.5% or 25mV	for 0-100% load change (with sense connected, <2% without)
Line Regulation	<0.5%	for 90 - 264Vac input change (210-264Vac for 1500W)
Cross Regulation	<0.2%	for 100% load change on any other output
Transient Response Recovery	<10%	of set voltage for 50% load change (above 25% load)
	500µs	for recovery to 1% or 100mV of set voltage (1000µs for S module)
Over Voltage Protection	Standard	for all outputs
Over Current Protection	Standard	for all outputs
Short Circuit Protection	<150%	of rated current, when output voltage <1%
Over Temperature Protection	Yes	Shuts down all outputs. Cycle ac off / on to reset

Note shutdown temp varies according to ambient, output power and input V



SAFETY APPROVALS					
	Date	Amendments		Date	Amendments
EN 60950-1	2001		IEC 60601-1 _a	1988	A1, A2
UL 60950-1	2003		UL 60601-1 _a	2003	
CSA22.2 No 60950-1	2003		CSA 60601-1 _a	2003	
IEC60950-1*	2001		CE Mark	LV Directive 2006/95/EC (EN60950-1)	
* CB Certificate and report available on request			a - Only for LL, RL and TL leakage variants. CA400 + CA1000 only		

PRODUCT, GENERIC & COLLATERAL STANDARDS				
Low Voltage Power Supply, EMC	EN61204-3: 2001	Compliant to High Severity Immunity	Class A emissions for CA1000 / CA1500	
Medical Electrical Equipment, EMC	EN61601-1-2: 2001	Compliant	Class A emissions for CA1000 / CA1500	
Immunity for residential, commercial and light industrial environments	EN61000-6-1: 2001	Compliant		
Immunity for industrial environments	EN61000-6-2: 2001	Compliant		
Emissions for industrial environments	EN61000-6-4: 2001	Compliant		

EMISSIONS			
Radiated Electric Field	EN55022	Class A (as per CISPR.22)	See application note for details. Only for 'S' type leakage versions
Conducted Emissions	EN55022	Class A (as per CISPR.22)	Only for 'S' type leakage versions.
Conducted Harmonics	EN61000-3-2: 2001	Compliant to Class A	
Flicker	EN61000-3-3: 1995 + A1:2001	Compliant - d _{max} only.	

IMMUNITY				Criteria
Electrostatic Discharge	EN61000-4-2	Level 4	Air discharge 15kV Contact discharge 8kV	A
Electromagnetic Field	EN61000-4-3	Level 3	10V/m (tested to 12V/m)	A
Fast / Burst Transient	EN61000-4-4	Level 4	Input 4kV Outputs 2kV, Tested at 5kHz and 100kHz	A
Surge Immunity	EN61000-4-5	Level 3	Line to Line (Differential) 1.1kV Line to Earth (Common Mode) 2.2kV	A
Conducted RF Immunity	EN61000-4-6	Level 3	10V (tested to 12V)	A
Power Frequency Magnetic Field	EN61000-4-8	Level 4	30A Continuous	A
Voltage Dips, Variation, Interruptions	EN61000-4-11	Class 3		A B for 5s interruptions
Voltage Fluctuations	EN61000-4-14	Class 3	For 100 to 240V nominal	A

ENVIRONMENT	
Temperature	0°C to 70°C operational, -40° to 85°C storage (max 12 months)
Derating	50°C to 70°C derate each output by 2.5% per °C
Low Temperature Start-up	-20°C
Humidity	5-95% RH non condensing
Shock	3000 shocks, each of 10g (16ms) half sine
Vibration	10 - 200Hz @ 1.5g
Altitude	3,000 metres operational (15,000 metres non operational)
Pollution	Degree 2, Material group 3
IP Rating	IP 10

ISOLATION					
Input to Output	Reinforced	4.3 kV (dc)	Output to Earth	Operational	500 V (dc)
Input to Earth	Basic	2.3 kV (dc)	Output to Output	Operational	500 V (dc)



OUTPUT VOLTAGES (single output modules)					(twin output modules)					
Module	Adjustment Range (Volts)	Amps	Slots		Module	V1 Adjustment Range (Volts)	Amps	V2 Adjustment Range (Volts)	Amps	Slots
A	4.5 - 5.5	60	2		E	5 - 16	8	5 - 16	8	1
AA	4.5 - 6.2	60	2		EB	4.5 - 5.5	9	4.5 - 5.5	9	1
B	4.5 - 5.5	25	1		EQ	4.5 - 5.5	9	2.7 - 3.9	9	1
BB	4.5 - 6.5	25	1		H	18 - 32	5 _c	18 - 32	5 _c	1
C	5 - 16	16 _a	1		P	18 - 29	5	5 - 16	8	1
D	18 - 29	8	1							
F	9 - 15.5	33	2							
G	17.5 - 29	25	2							
J	30 - 48	10 _b	2							
K	18 - 29	15	2							
L	1.8 - 3.2	25	1							
M	5 - 16	8	1							
N	18 - 32	5 _c	1							
Q	2.7 - 3.9	25	1							
R	2.7 - 3.9	60	2							
S	2.5 - 5.7	85	2							
T	1.8 - 3.2	60	2							
U	10 - 21	16	1							
V	10 - 21	25	2							
W	4.5 - 5.5	15	1							
Z	4.5 - 5.5	25	1							

a) 12A max above 12V
b) Derate output current by 0.25A / V above 40V
c) 1A max above 29V

Alpha Configuring Guide

The extensive range of output modules and options make it possible to achieve many combinations of Volts and Amps. To achieve the optimum configuration, please contact our sales office. However you can also create your own configuration from this datasheet by using the guide below.

Configuring from Datasheet

- 1 Calculate total output power to determine Alpha 1000W or 1500W and select converter, then select required Cooling and Leakage Current from the following table:-

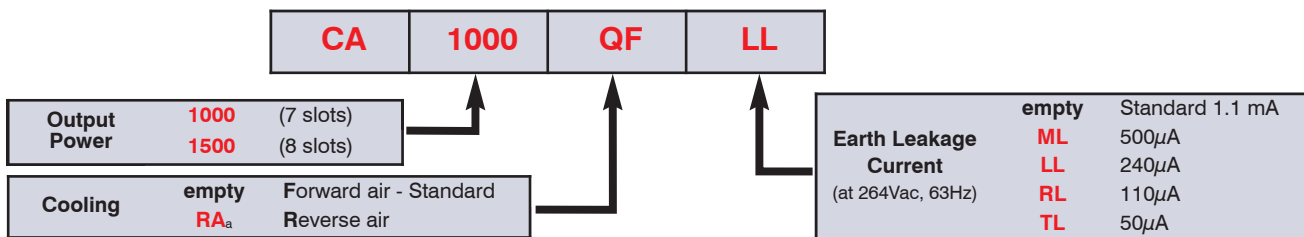

Notes:

- a) Contact sales office for details

- 2 Select Output Modules and Options from the Output Voltages tables.

Example - if you require 5.2V / 18A with output inhibit :-

- a) select B as closest match for voltage and current and prefix with voltage (e.g. **5.2B**)
- b) add suffix for option (if required)
 - ‘PA’ for parallel/current share (for N+1 redundant applications)
 - ‘PP’ for parallel (increase current from one PSU)
 - ‘IN’ for inhibit
 - ‘RP’ for remote programming
 - ‘MF’ (only applicable on 1st module) for global inhibit, ac fail and 5V/50mA standby supply
- c) repeat for other outputs

Ensure that the total width of all selected modules is within the slots for the chosen converter. For example:-

CA1000 5A 12/12E 24G which represents a four output 1000W Alpha with Forward air, 1.1mA Earth Leakage, with:-

- Output 1 = 5V / 60A with remote sense
- Output 2 = 12V / 8A
- Output 3 = 12V / 8A
- Output 4 = 24V / 25A with remote sense

- 3 Contact TDK-Lambda to validate configuration and issue a part number.



Option Connections

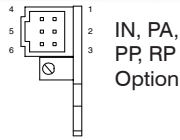

Pin	IN option	PA option	PP option	RP option	MF option
1	n/c	+ Sense	+ Sense	+ Sense	Inhibit (low)
2	Module Good	Module Good	n/c	- Sense	5V supply
3	Inhibit	Star point	n/c	Control 2	Power Fail
4	n/c	- Sense	- Sense	n/c	0V
5	- Power	- Power	n/c	Control 1	Inhibit (high)
6	- Power	Star point	n/c	n/c	n/c

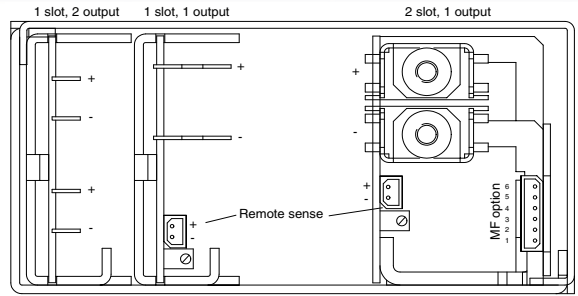

Alpha 1000

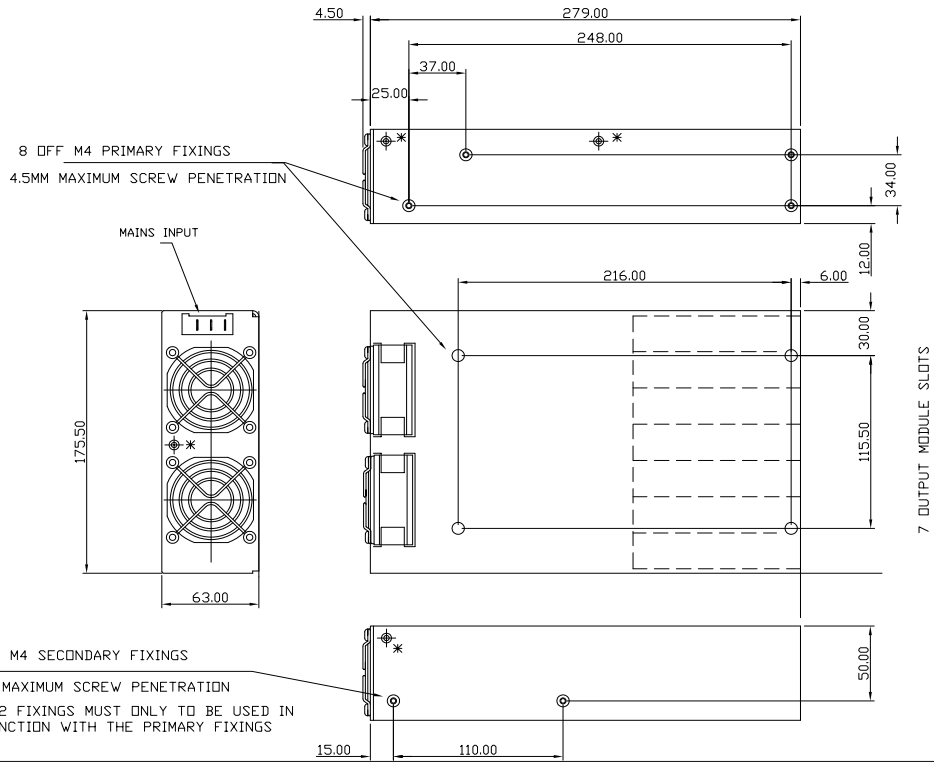

Alpha 1500

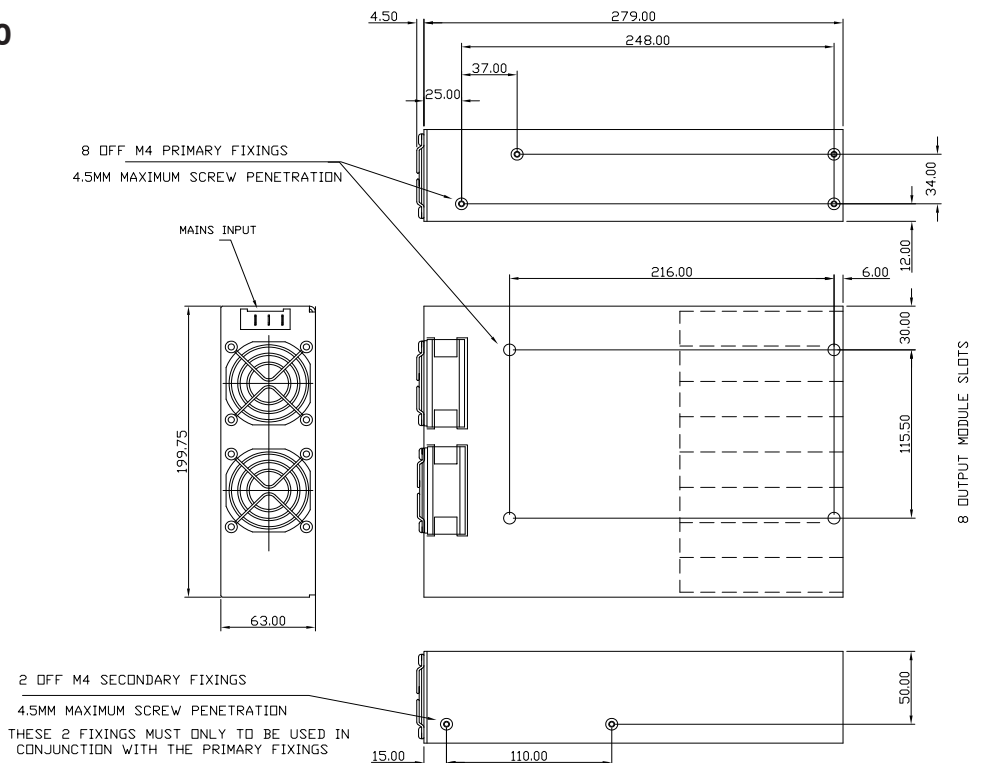



DIN Rail Mounting AC-DC Power Supplies and DC-DC Converters

The DPP range is a complete family of standard DIN rail mounting power supplies with output power from 15W to 960W. Models from 120W upwards can be paralleled if increased power is needed. Single phase and three phase mains inputs are catered for. The DSP range from 7.5W to 100W has a specific low profile design with standard width sizes to fit standard wall-mounted control panels. Output voltages from 5V to 48V are available in addition to the most popular 24V models. DPX models are single, dual or triple output dc-dc converters up to 60W intended to provide additional auxiliary voltages.



DSP Series 7.5 -100W Single Output

Page No.

137



DPP15-100 Series 15 -100W Single Output

140



DPP120-240 1PH Series 120 - 240W Single Output

143



DPP480 1PH Series 480W Single Output

146



DPP120 - 960 3PH Series 120 - 960W Single Output

149



DPX Series 15-60W Single, Dual & Triple Output

152



- Low Profile for Building Automation
- 5V to 24V Outputs
- Wide Range AC Input
- -25°C to +71°C Operation
- Convection Cooled
- UL1310 Class 2
- Class II Double Insulation

DSP Series

7.5W to 100W Low Profile
Din Rail Mount Power Supplies

Key Market Segments & Applications

Building Services Automation: Alarms and Security, Access and Fire Safety Systems, Lighting and Environment Control Systems.

DSP Features and Benefits

Features

- Low 56mm Profile
- Wide Range AC
- Convection cooled

Benefits

- Fits into wall mounted cabinets
- Global use with no input selector switches
- No system fan required

Specifications

ITEMS	MODEL	DSP10				DSP30				DSP60				DSP100			
		DSP10		DSP30		DSP60		DSP100		DSP10		DSP30		DSP60		DSP100	
AC Input Voltage range	VAC	90 - 264VAC, Class II double insulated (No ground connection required)															
Input Frequency	Hz	47 - 63Hz															
DC Input Voltage range	VDC	120 - 370VDC															
Inrush Current (115 / 230VAC)	A	15 / 30A				25 / 50A				30 / 60A				30 / 60A			
Power Factor		Meets EN61000-3-2, EN61000-3-3															
Output Voltage Accuracy	%	±1% of Nominal															
Line Regulation	%	1%															
Load Regulation	%	1%															
Ripple and Noise (20MHz BW)	mV	50mV ⁽¹⁾															
Overcurrent Protection (Typ)	-	110 - 160%, fold forward under short circuit (DSP100-24/C2 102-108%)															
Overvoltage Protection	V	120 - 145%															
Hold Up Time (115VAC input)	ms	See Model Selector															
LED Indicators	-	Green LED = On, Red LED = DC Output Low															
Operating Temperature	-	-25 to +71°C (Derate linearly 2.5%/°C from 55 to 71°C)															
Temperature Coefficient	%/°C	±0.02%/°C															
Storage Temperature	-	-25°C to +85°C															
Operating Humidity	-	20 - 95% RH (non condensing)															
Cooling	-	Convection															
Withstand Voltage	-	Input to Output 3kVAC for 1 min.															
Isolation Resistance	Ω	>100MΩ at 25°C & 70%RH, Input to Ground 500VDC															
Vibration (Operating)		IEC60068-2-6 (Mounting by rail: Random wave, 100-500Hz, 2G, ea. along X, Y, Z axes 10min/cycle, 60 min)															
Shock (Operating)		IEC60068-2-27 (Half sine wave, 4G, 22ms, 3 axes, 6 faces, 3 times for each face)															
Safety Agency Approvals	-	UL1310 Class 2 ⁽²⁾ , UL508 Listed, UL60950-1, EN60950-1, CE															
Immunity	-	EN61000-4-2, -3, -4, -5, -6, -8 & -11															
Conducted & Radiated EMI	-	EN55022 class B				EN55022 class A											
Weight (Typ)	g	60				200				250				320			
Size (WxHxD)	mm	18 x 91 x 55.6				53 x 91 x 55.6				71 x 91 x 55.6				90 x 91 x 56.8			
Case material	-	Plastic															
Warranty	yrs	2															

Note 1: For DSP100-24/C2 Ripple & Noise measured with Vin 115- 230 Vac

Note 2: Excludes Models: DSP60-5, DSP60-12, DSP100-12, DSP100-15, DSP100-24



Model Selector

Model	Voltage (V)	Voltage Adjust (V)	Current (A)	Power (W)	Efficiency (Typ %)	HoldUp Time 115VAC in (ms)
DSP10-5	5	None	1.5	7.5	74	10
DSP30-5	5	5 - 5.5	3.0	15.0	74	25
DSP60-5	5	5 - 5.5	7.0	35.0	80	16
DSP10-12	12	None	0.83	10.0	78	10
DSP30-12	12	12 - 14	2.1	25.2	82	25
DSP60-12	12	12 - 14	4.5	54.0	84	16
DSP100-12	12	12 - 14	6.0	72.0	82	16
DSP10-15	15	None	0.67	10.1	78	60
DSP30-15	15	13.5 - 16.5	2.0	30.0	83	25
DSP60-15	15	13.5 - 16.5	4.0	60.0	85	12
DSP100-15	15	13.5 - 16.5	5.0	75.0	85	16
DSP10-24	24	None	0.42	10.1	80	60
DSP30-24	24	24 - 28	1.3	31.2	83	25
DSP60-24	24	24 - 28	2.5	60.0	86	12
DSP100-24/C2	24	20 -24.2	3.8	91.2	89	10
DSP100-24	24	24 - 28	4.2	100.8	85	10

Outline Drawing DSP10 Series

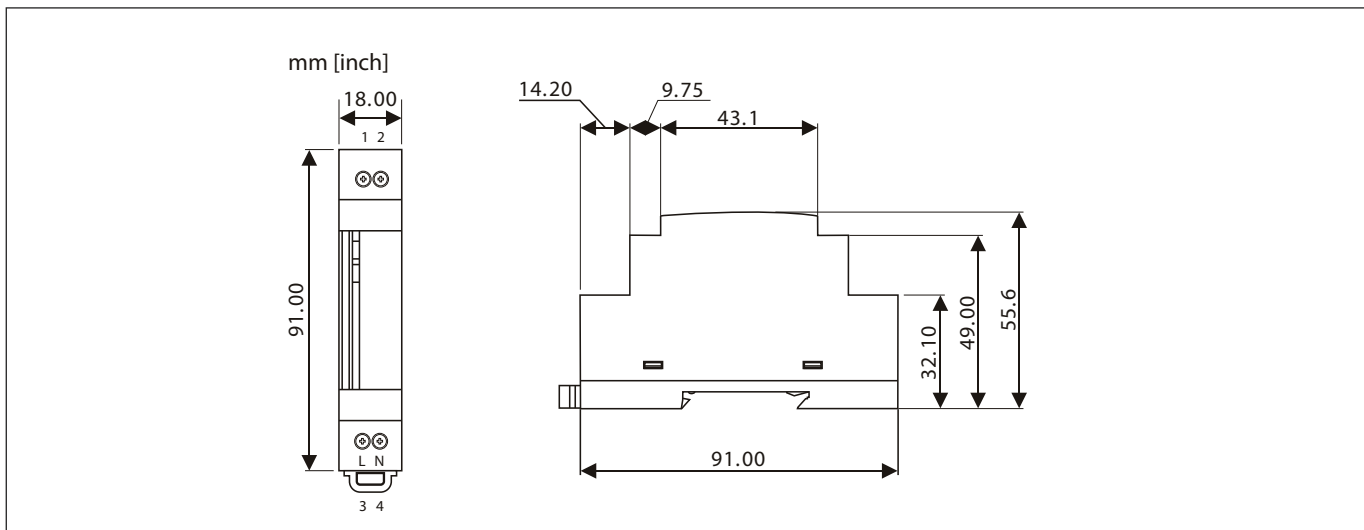



Outline Drawing DSP30 Series

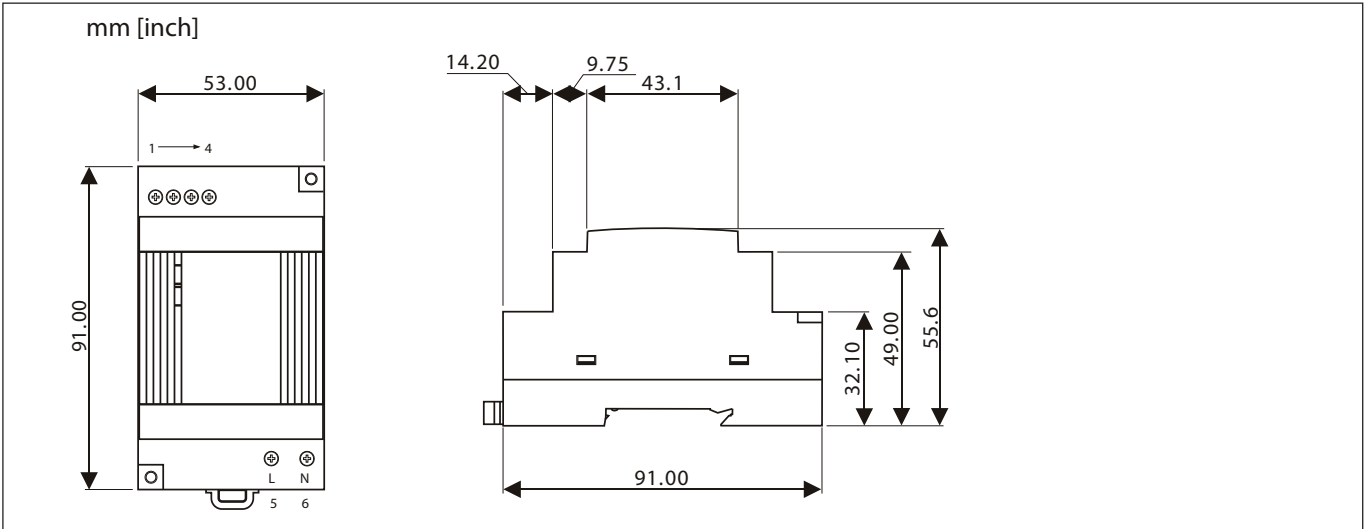

Outline Drawing DSP60 Series

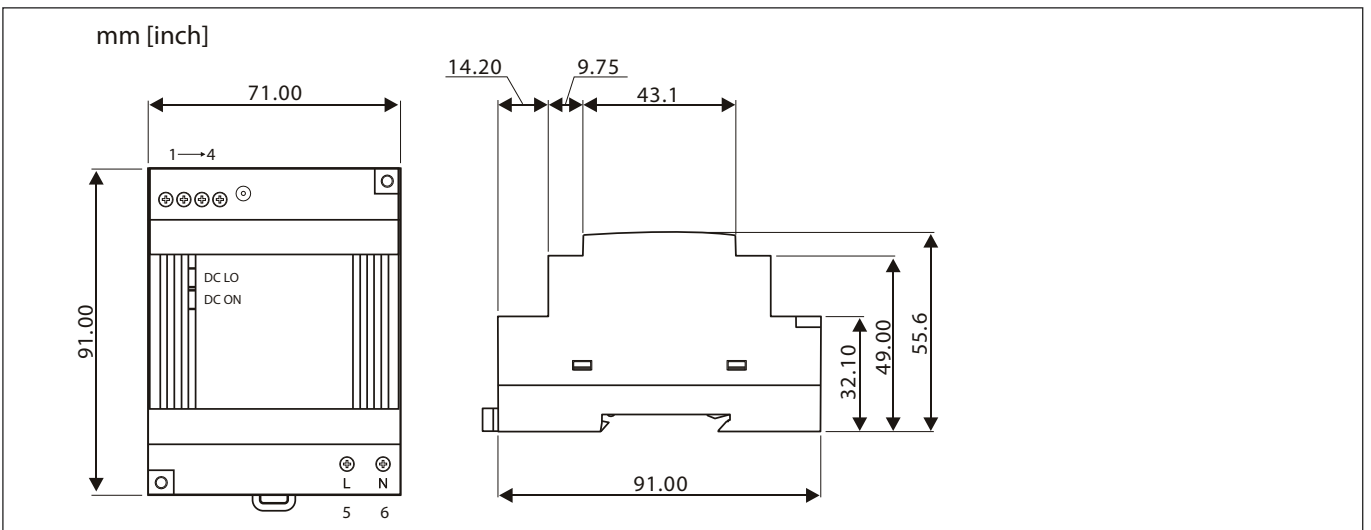

Outline Drawing DSP100 Series

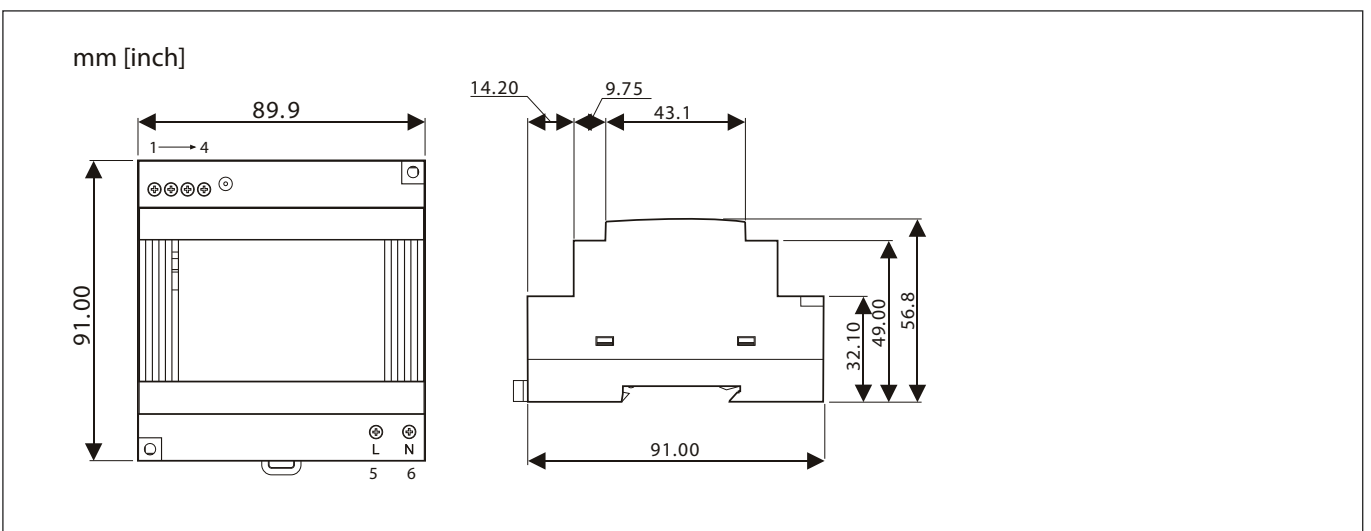



- Low Cost
- 5V to 48V Outputs
- Universal Input
- Compact Size
- NEC Class 2 Compliant
- UL508 Listed
- -10°C to +71°C Operation
- RoHS Compliant

DPP15-100 Series

15-100W, 5-48V Output
DIN Rail Mount Power Supplies

Key Market Segments & Applications

- Industrial Controls: Motor Control Systems
- Factory Automation: Process Control, Automotive, Chemical Processing
- Test & Measurement: Burn in & Test, Instrumentation Measurement

DPP15-100 Features and Benefits

Features

- PFC Compliant to EN61000-3-2
- UL508 Approvals
- TS35/7.5 or TS35/15 DIN Rail Mounting

Benefits

- Supports Global Use
- Easier System Configuration
- Easy System Integration

Specifications

ITEMS	MODELS		DPP15	DPP25/30	DPP50	DPP100
	(1)	VAC				
AC Input Voltage range	(1)	VAC	85 - 264VAC			85 - 132VAC 176 - 264VAC
Input Frequency		Hz	47 - 63Hz			
DC Input Voltage range		-	90 - 375VDC			210 - 375VDC
Inrush Current (115 / 230VAC)		A	<35A	35 / 45A	35 / 50A	35 / 55A
Power Factor		-	Meets EN61000-3-2 Class A			
Max Input Current (230VAC)		A	0.4	0.72	1.35	2.2
Output Voltage Accuracy		%	±1% (24V outputs preset at 24.5V)			
Line Regulation		%	< 0.5%			
Load Regulation		%	< 0.5%			
Ripple/Noise		mV	<50mV (20MHz Bandwidth)			
Overcurrent Protection (Typ)		-	>120%			
Overvoltage Protection		V	125 - 137.5%, Cycle AC line to reset			
Hold Up Time (115VAC input)		ms	> 20ms			
Parallel switch		-	No			Yes
LED Indicator		-	Green LED = On			
Operating Temperature		-	-10°C to +71°C (Derate linearly 5%/°C from 61°C to 71°C)			
Storage Temperature		-	-25°C to +85°C			
Operating Humidity		-	20 - 90% RH (non condensing)			
Cooling	(2)	-	Convection			
Withstand Voltage		-	Input to Output 3kVAC for 1 min.			
Shock		-	Half sine wave, 4G, 22ms, 3 times per face, X, Y, Z			
Vibration		-	10-500Hz (20 min sweep) 0.002G ² /Hz, 1Grms acceleration X, Y, Z, 1 hour			
Isolation Resistance		Ω	>100MΩ at 25°C & 70%RH, Output to Ground 500VDC			
Safety Agency Approvals		-	UL60950-1, UL508, UL1310 ⁽³⁾ (Class 2), EN60950-1, CE Mark			
Emissions		-	EN55011, EN55022 Class B Radiated & Conducted, EN61000-6-3			
Immunity		-	EN61000-6-2, EN61000-4-2 Level4, EN61000-4-3, EN61000-4-6 Level 3			
			EN61000-4-4 Level 4 (I/P) Level 3 (O/P), EN61000-4-5 Level 4, EN61000-4-8, EN61000-4-11			
Weight (Typ)		g	130	260	390	
Size (WxHxD)		mm	23 x 75 x 97	45 x 75 x 91	73 x 75 x 97	
Case material		-	Plastic			
MTBF (MIL-HDBK-217F, GF25)		Hours	287,000	>288,000	273,000	239,000
Warranty		yrs	2			

(1) Auto Select - DPP100 only

(2) Recommend 25mm clearance on all sides.

(3) Does not include DPP25-5 & DPP100-24 models. Evaluated to NEC NFPA70 Class 2 output per UL1310.



Model Selector

Model	Output Voltage (V)	Output Adjust (V)	Output Curr. (A)	Max. Output Power (W)	Efficiency at Full Load (%)
DPP25-5	5	5-6	5	25	78
DPP30-12	12	9.9-12.1	2.5	30	82
DPP50-15	15	11.9-15.1	3.4	50	85
DPP15-24	24	22.5-28.5	0.63	15	80
DPP30-24	24	22.5-28.5	1.3	30	84
DPP50-24	24	22.5-28.5	2.1	50	86
DPP100-24	24	22.5-28.5	4.2	100	87
DPP50-48	48	48-56	1.05	50	87

Installation

Snap-on Mounting - snap onto DIN Rail TS35/7.5 or TS35/15 (no tools required)

Cooling - Normal Convection

Clearance - 25mm all sides

Connection - Use copper wire 0.5-2.5mm² (AWG24-12)

Outline Drawing DPP15 Series

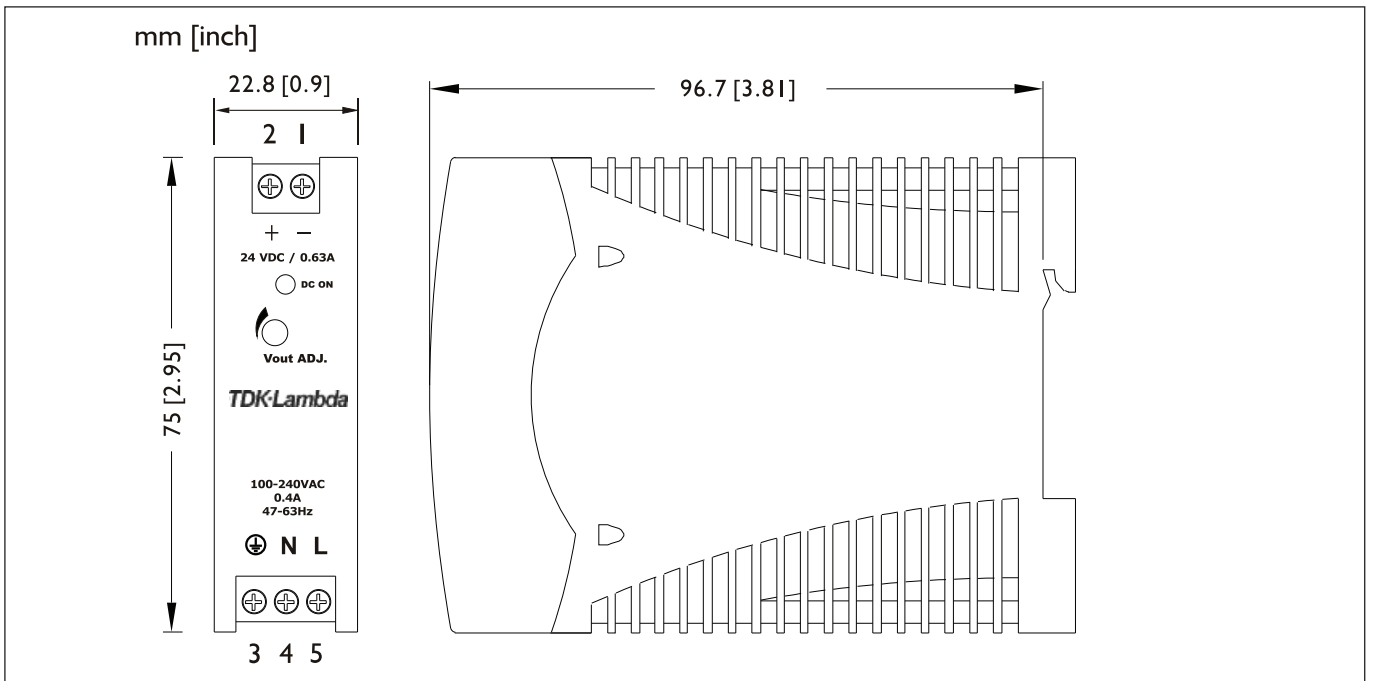



Outline Drawing DPP25-DPP50 Series

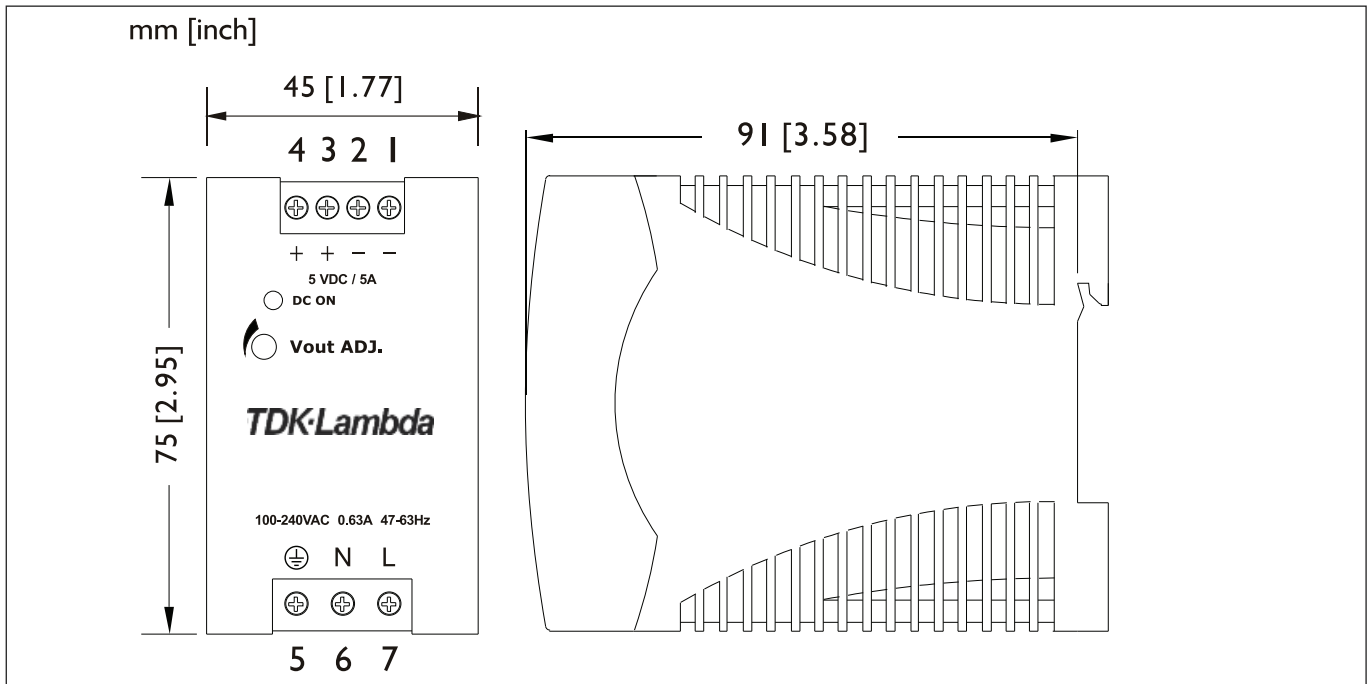

Outline Drawing DPP100 Series

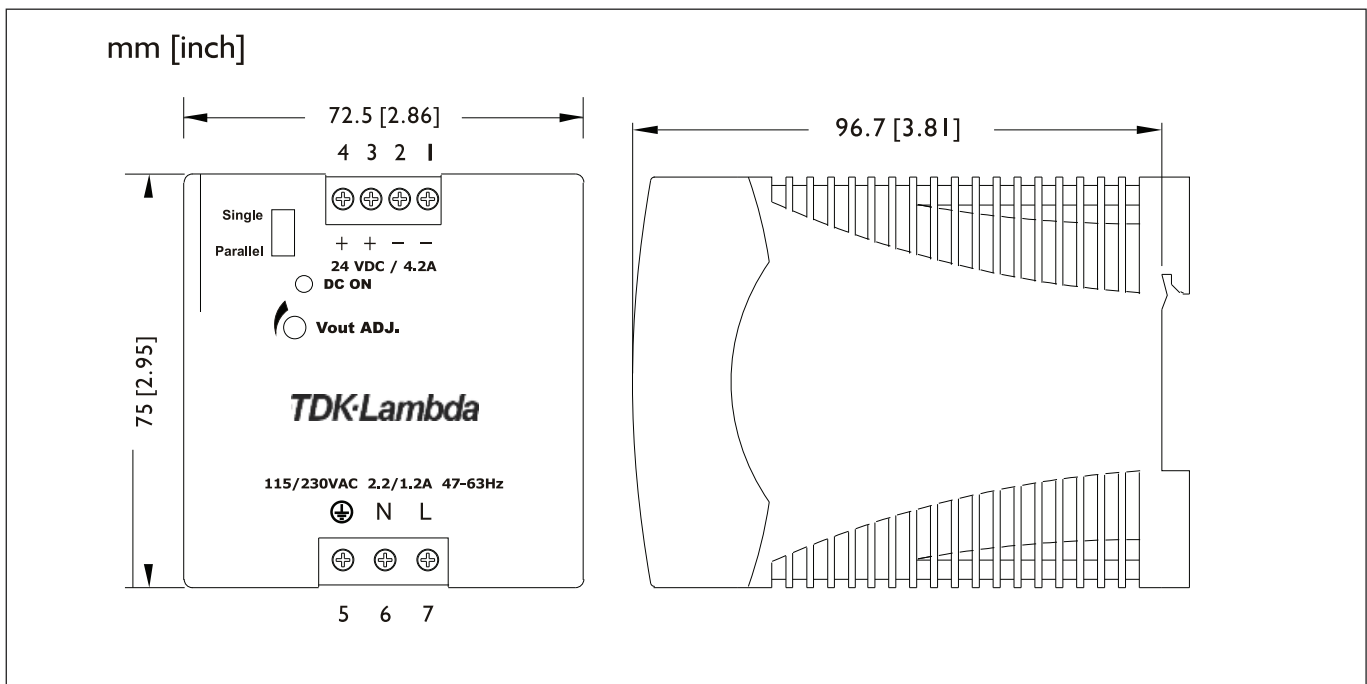



DPP120 & 240 Series

120W & 240W Single Output
DIN Rail Mount Power Supplies

- Low Cost
- 12, 24 or 48V Outputs
- Wide Range AC Input
- Parallel Function Switch
- -25°C to +71°C Operation

Key Market Segments & Applications

Industrial Controls:	Motor Control Systems
Factory Automation:	Process Control, Automotive, Chemical Processing
Test & Measurement:	Burn in & Test, Instrumentation Measurement

DPP120 & 240 Features and Benefits

Features

- PFC Compliant to EN61000-3-2
- UL508 Approvals
- TS35/7.5 or TS35/15 DIN Rail Mounting

Benefits

- Supports Global Use
- Easier System Configuration
- Easy System Integration

Specifications

MODELS		DPP120	DPP240
ITEMS			
AC Input Voltage range	VAC	90 - 132/186-264VAC (auto select)	
Input Frequency	Hz	47 - 63Hz	
DC Input Voltage range	VDC	210 - 370VDC	
Inrush Current (115 / 230VAC)	A	24/48A	30/60A
Power Factor	-	typ 0.7 at 230VAC input	
Input Current (115/230VAC)	A	2.8/1.4A	5.4/2.2A
Output Voltage	V	12, 24 or 48V	24 or 48V
Output Voltage Accuracy	%	-0, +1% of Nominal	
Line Regulation	%	±0.5%	
Load Regulation	%	±1% Single Mode ±5% Parallel Mode	
Ripple and Noise (20MHz BW)	mV	<50mV	<100mV
Overcurrent Protection (Typ)	-	120 - 145%	
Overvoltage Protection	V	120 - 145%	
Hold Up Time (230VAC input)	ms	>30 ms	
Efficiency (typ)	%	84 - 90% (see table)	
Parallel Operation (1)	-	Up to 3 units	
LED Indicators	-	Green LED = On, Red LED = DC Output Low	
DC Good Relay (24V model only)	-	-0.3A rated normally open relay contacts, closes when output is above 17.6 - 19.4V	
Operating Temperature	-	-25°C to +71°C (Derate linearly 2.5% per °C from 61°C to 71°C)	
Storage Temperature	-	-25°C to +85°C	
Operating Humidity	-	20 - 95% RH (non condensng)	
Cooling	-	Convection	
Withstand Voltage	-	Input to Output 3kVAC for 1 min.	
Isolation Resistance	Ω	>100MΩ at 25°C & 70%RH, Output to Ground 500VDC	
Vibration (Operating)	-	IEC 60068-2-6 (Mounting by rail: Random wave, 10-500 Hz, 2G, ea. along X, Y, Z axes 10 min/cycle, 60 min)	
Shock (Operating)	-	IEC 60068-2-27 (Half sine wave, 4G, 22ms, 3 axes, 6 Faces, 3 times for each face)	
Safety Agency Approvals	-	UL508 Listed, UL60950-1, EN60950-1, CE	
Conducted & Radiated EMI	-	EN55022 class B	
Weight (Typ)	g	920	1000
Size (HxWxD)	mm	125 x 63.5 x 123.6	125 x 83 x 126
Case material	-	Metal	
Warranty	yrs	2	



Notes: (1) For parallel operations a minimum 10% load is required - loading conditions 0.1Io min to 0.9Io max

Model Selector					
Model	Voltage (V)	Voltage Adjust (V)	Current (A)	Power (W)	Effic. (typ) %
DPP120-12	12	11.4 - 14.5	10	120	84
DPP120-24	24	22.5 - 28.5	5	120	86
DPP120-48	48	45 - 55	2.5	120	87
DPP240-24	24	22.5 - 28.5	10	240	89
DPP240-48	48	47 - 56	5	240	90

For plug type connectors add suffix 'B' to part number

PIN Assignments	
Pin#	Function
1	DC Good Relay
2	DC Good Relay
3	V+
4	V+
5	V-
6	V-
7	GND
8	L
9	N



Outline Drawing DPP120

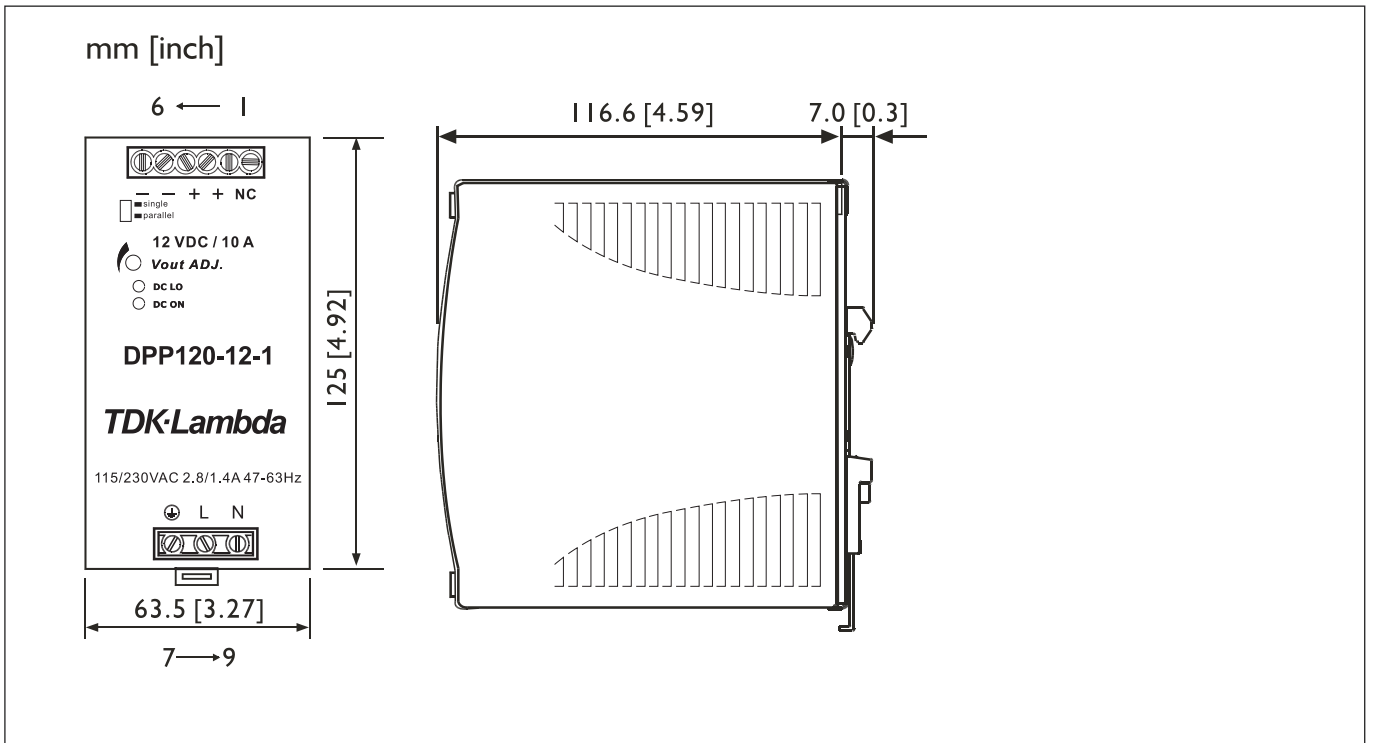

Outline Drawing DPP240

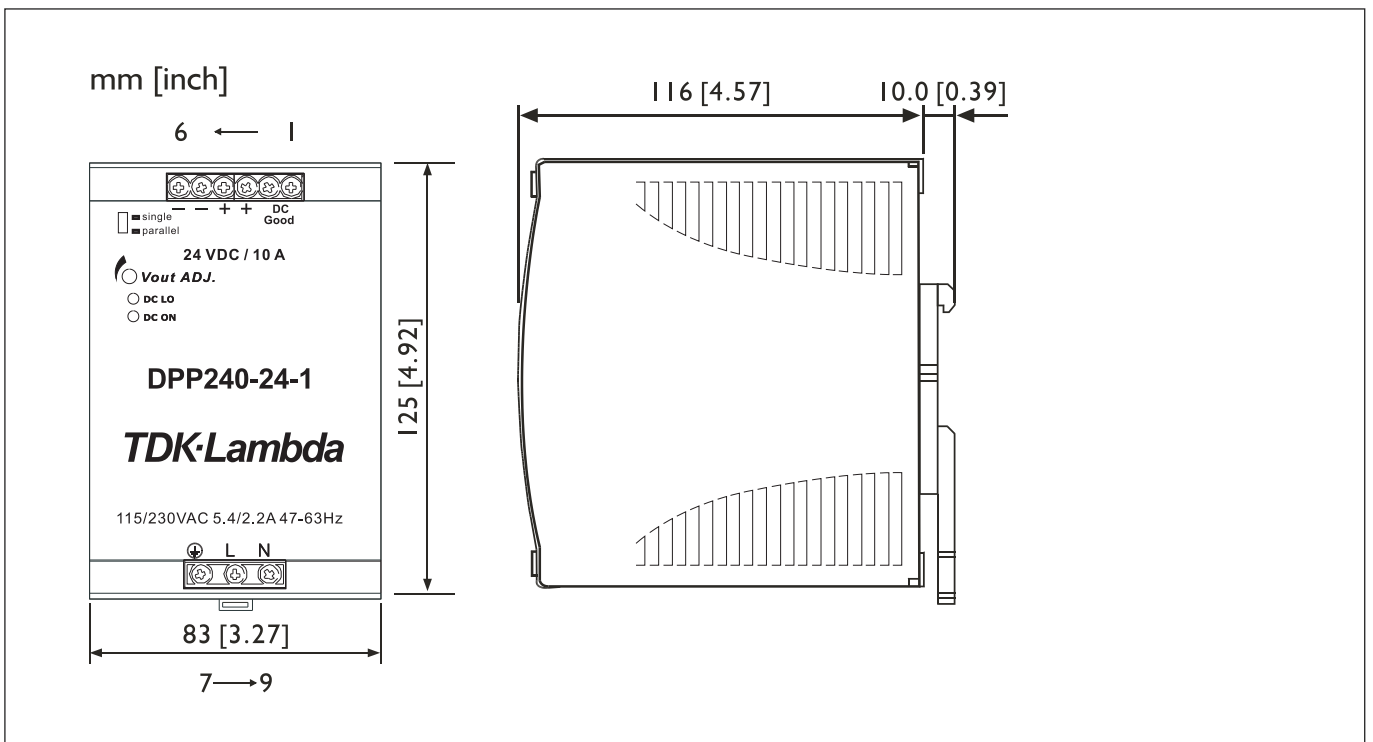



- Low Cost
- 24 or 48V Outputs
- Wide Range AC Input
- Active PFC
- Parallel Function Switch
- -25°C to +71°C Operation

DPP480 Series

480W Single Output
DIN Rail Mount Power Supplies

Key Market Segments & Applications

Key Market Segments & Applications

- Industrial Controls: Motor Control Systems
- Factory Automation: Process Control, Automotive, Chemical Processing
- Test & Measurement: Burn in & Test, Instrumentation Measurement

DPP480 Features and Benefits

Features

- PFC Compliant to EN61000-3-2
- UL508 Approvals
- TS35/7.5 or TS35/15 DIN Rail Mounting

Benefits

- Supports Global Use
- Easier System Configuration
- Easy System Integration

Specifications

MODELS		DPP480-24-1	DPP480-48-1
ITEMS			
AC Input Voltage range	VAC	90 - 264VAC	
Input Frequency	Hz	47 - 63Hz	
DC Input Voltage range	VDC	120 - 370VDC	
Inrush Current (115 / 230VAC)	A	25 / 50A	
Power Factor	-	Meets EN61000-3-2 Class A, typ 0.99 at 230VAC input	
Input Current (115/230VAC)	A	7 / 3.5A	
Output Voltage	V	24V	48V
Output Current	A	20A	10A
Output Voltage Adjustment Range	-	22.5 - 28.5V	47 - 56V
Output Voltage Accuracy	%	-0, +1% of Nominal	
Line Regulation	%	±0.5%	
Load Regulation	%	±0.5% (±5% when set in parallel mode)	
Ripple and Noise (20MHz BW)	mV	100mV	
Overcurrent Protection (Typ)	-	120 - 140%	
Overvoltage Protection	V	30 - 33V	57 - 63V
Hold Up Time (115VAC input)	ms	> 30ms	
Efficiency (typ)	%	89%	90%
Parallel operation	-	Set in single or parallel (droop) mode - maximum of 3 units	
LED Indicators	-	Green LED = On, Red LED = DC Output Low	
DC Good Relay (24V model only)	-	0.3A rated normally open relay contacts, closes when output is above 17.6 - 19.4V	
Operating Temperature	--	-25°C to +71°C (Derate linearly 2.5%/°C from 56°C to 71°C) ⁽²⁾	
Storage Temperature	-	-25°C to +85°C	
Operating Humidity	-	20 - 95% RH (non condensing)	
Cooling	(1) -	Convection	
Withstand Voltage	-	Input to Output 3kVAC for 1 min.	
Isolation Resistance	Ω	>100MΩ at 25°C & 70%RH, Output to Ground 500VDC	
Safety Agency Approvals	-	UL508 Listed, UL60950-1, EN60950-1, CE	
Conducted & Radiated EMI	-	EN55022 class B	
Weight (Typ)	g	1920g	
Size (WxHxD)	mm	175 x 125 x 123	
Case material	-	Metal	
Warranty	yrs	2	

Notes:

- (1) Recommend 1" clearance on all sides
- (2) Derating curve applies for input of 110V and above. For 90V input derating at 4% per deg



Model Selector

Model	Output Voltage (V)	Output Adjust (V)	Output Curr. (A)	Max. Output Power (W)	Efficiency at Full Load (%)
DPP480-24-1	24	22.5 - 28.5	20	480	89
DPP480-48-1	48	47.0 - 56.0	10	480	90

For plug type connectors add suffix 'B' to part number

PIN Assignments

Pin#	Function
1	DC Good Relay
2	DC Good Relay
3	V+
4	V+
5	V-
6	V-
7	GND
8	N
9	L



Outline Drawing DPP480 Series

Dimensions are in millimeters (inches)

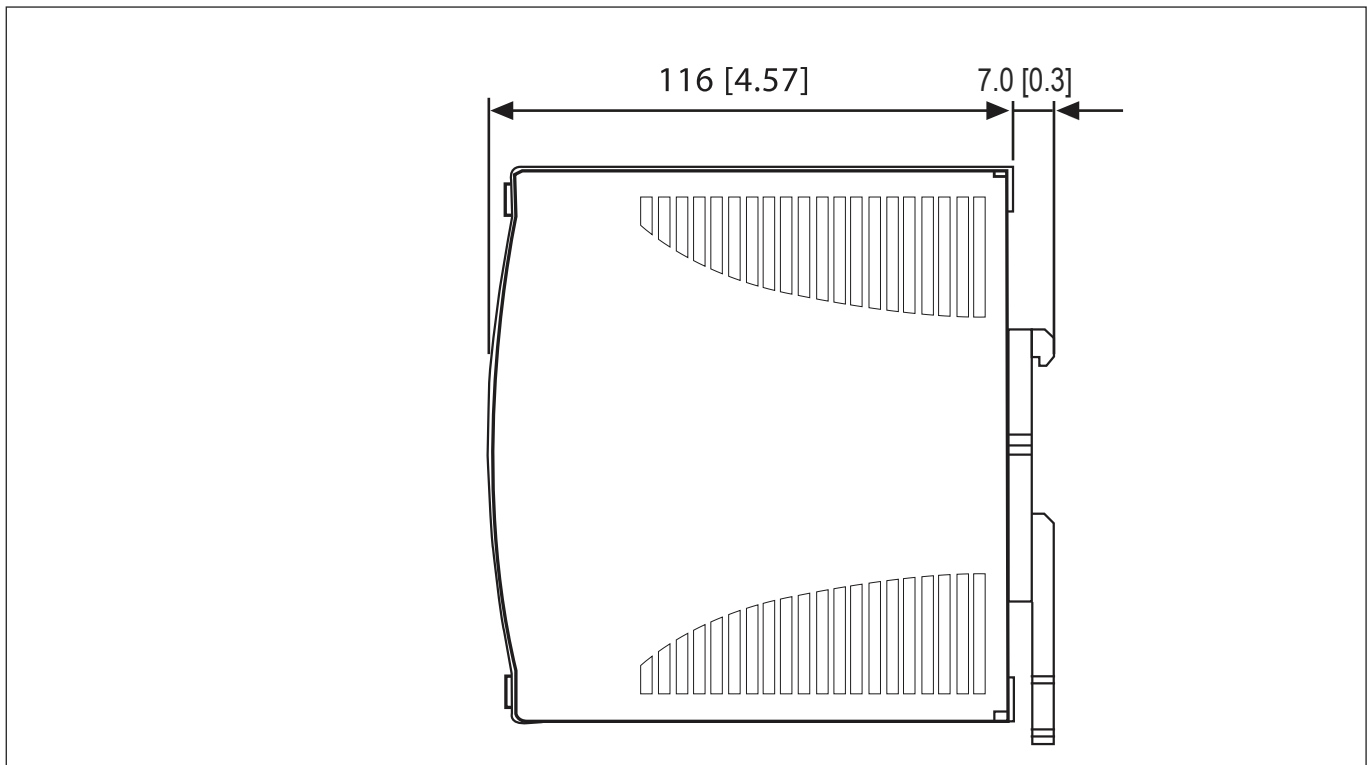
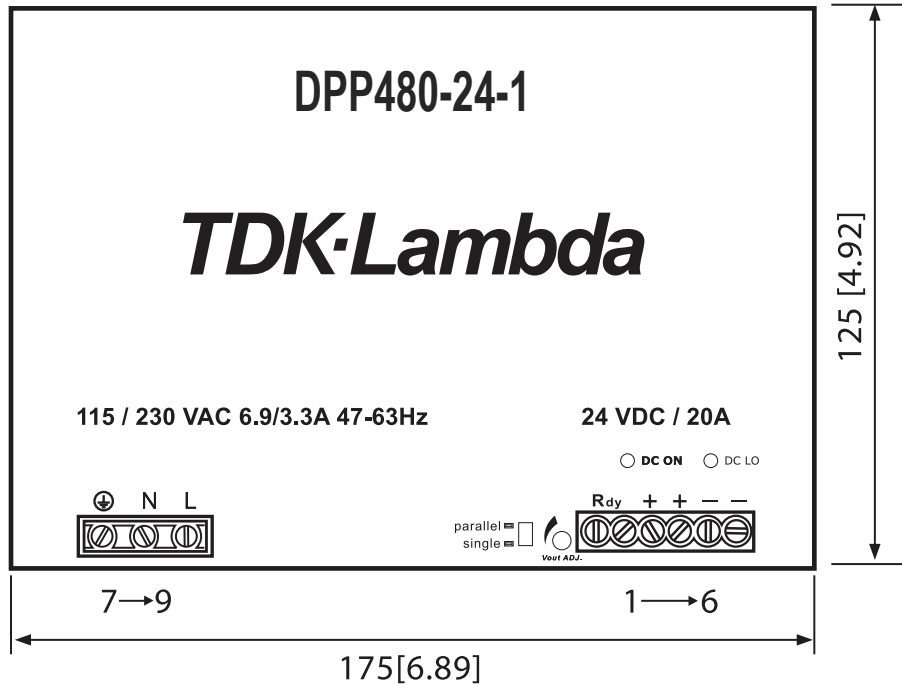



- Low Cost
- 12V, 24V or 48V Outputs
- Wide Range 340 to 575VAC Input
- Parallel Function Switch (240 & 480W)
- Current Share (960W)
- -25°C to +71°C Operation
- Convection Cooled

DPP120 - 960 Series

120W, 240W, 480W & 960W
3 Phase DIN Rail Mount Power Supplies

Key Market Segments & Applications

Industrial Controls:	Motor Control Systems
Factory Automation:	Process Control, Automotive, Chemical Processing
Test & Measurement:	Burn in & Test, Instrumentation Measurement

DPP120 - 960 Features and Benefits

Features

- PFC Compliant to EN61000-3-2
- UL508 Approvals
- TS35/7.5 or TS35/15 DIN Rail Mounting

Benefits

- Supports Global Use
- Easier System Configuration
- Easy System Integration

Specifications

MODELS		DPP120-xx-3	DPP240-xx-3	DPP480-xx-3	DPP960-xx-3
ITEMS					
AC Input Voltage range (1)	VAC	340 - 575VAC, three phase			
Input Frequency	Hz	47 - 63Hz			
DC Input Voltage range	VDC	480 - 820VDC			
Inrush Current (380-480VAC) (typ)	A	10A	20A	20A	30A
Power Factor (2)	-	0.55	0.55	0.65	0.8
Input Current (400VAC) (typ)	A	0.36A	0.65A	1.1A	1.72A
Output Voltage Accuracy	%	-0, +1% of Nominal			
Line Regulation	%	±1%			
Load Regulation	%	±1% (±5% when set in parallel mode)			
Ripple and Noise (20MHz BW)	mV	100mV	100mV	100mV	80mV
Overcurrent Protection (Typ)	-	115 - 135%	120 - 140%	110 - 135%	110 - 130%
Overvoltage Protection	V	See model selector			
Overtemperature Protection	-	Yes, auto recovery			
Hold Up Time (380-480VAC)	ms	> 20ms	> 20ms	> 20ms	> 15ms
Parallel operation (up to 90% load)	-	Set in parallel (droop) mode - up to 2 units			
LED Indicators	-	Green LED = On, Red LED = DC Output Low			
DC Good Relay (24V models only)	-	0.3A rated normally open relay contacts, closes when output is above 17.6 - 19.4V			
Operating Temperature	-	-25°C to +71°C (Derate linearly 2.5%/°C from 61°C to 71°C, 3.5%/°C for DPP960)			
Storage Temperature	-	-25°C to +85°C			
Operating Humidity (non condensing)	-	20 - 95% RH			
Cooling	-	Convection. Recommend 25mm clearance on all sides			
Withstand Voltage	-	Input to Output 3kVAC, Input to Ground 1.5kVAC for 1 min.			
Isolation Resistance	Ω	>100MΩ at 25°C & 70%RH, Output to Ground 500VDC			
Vibration	-	IEC 60068-2-6. 10- 500Hz, 2G on X, Y & Z axes			
Shock	-	IEC 60068-2-27. Half sinewave, 4G, 22ms, 3 times each face			
Safety Agency Approvals	-	UL508 Listed, UL60950-1, EN60950-1, CE			
Conducted & Radiated EMI	-	EN55022 class B			
Immunity	-	IEC 61000-4-2, -3, 4, -5, -6, -8, -11			
Weight (Typ)	g	800	1100	1720	3400g
Size (WxHxD)	mm	74.3 x 124 x 111.9	89 x 124 x 111.9	150 x 124 x 111.9	275.8 x 126.2 x 111.9
Switching Frequency	kHz	70	25	80	52
MTBF (Bellcore Issue 6 @ 40°C, GB)	Hours	527,000	488,000	411,000	352,000
Case material	-	Metal			
Warranty	yrs	2			



Model Selector

Model	Voltage (V)	Adjust Range (V)	Output Current (A)	Overvoltage (V)	Efficiency (%)
DPP120-12-3	12V	11.4 - 14.5V	10A	14.5 - 17.4V	87%
DPP120-24-3	24V	22.5 - 28.5V	5A	30 - 33V	89%
DPP240-24-3	24V	22.5 - 28.5V	10A	30 - 33V	90%
DPP480-24-3	24V	22.5 - 28.5V	20A	30 - 33V	90%
DPP960-24-3	24V	22.5 - 28.5V	40A	30 - 33V	92%
DPP240-48-3	48V	47 - 56V	5A	60 - 68V	91%
DPP480-48-3	48V	47 - 56V	10A	60 - 68V	91%
DPP960-48-3	48V	47 - 56V	20A	60 - 68V	93%

See Notes from Page 1

(1) Bi phase input is permissible, but output load must be derated to 75%

(2) Passive, meets EN61000-3-2



Outline Drawing DPP120

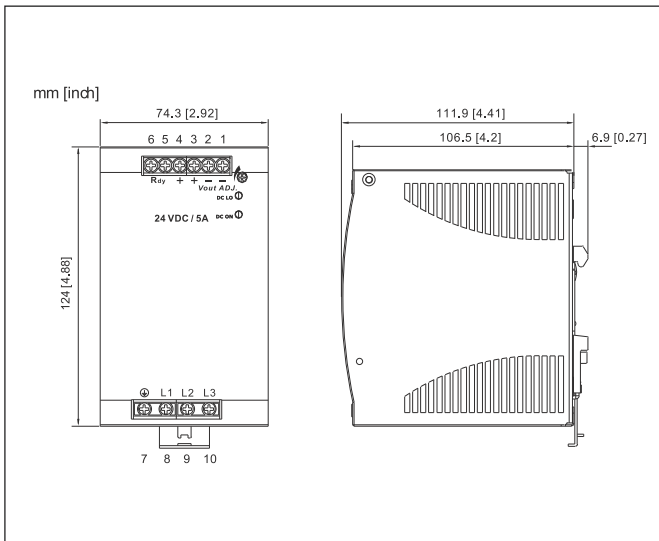

Outline Drawing DPP240

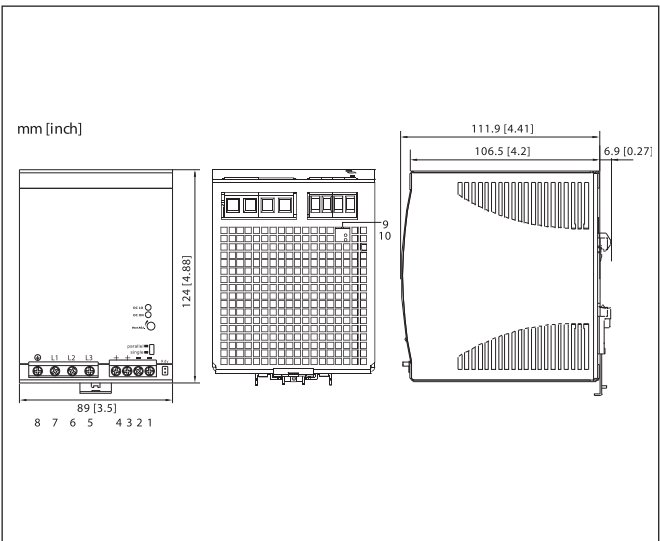

Outline Drawing DPP480

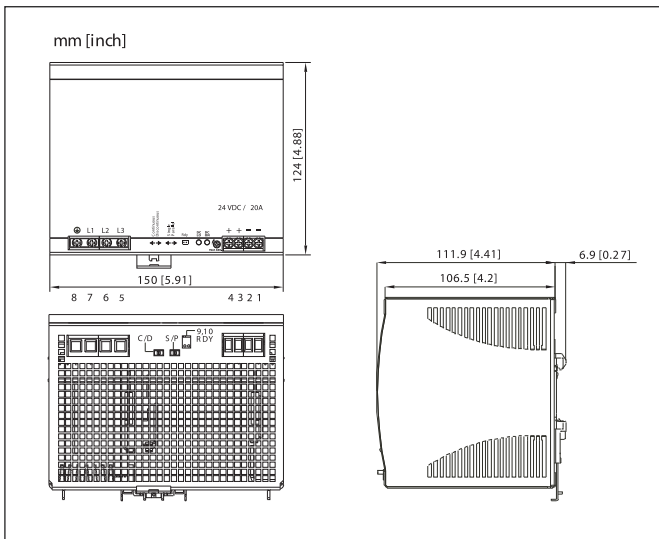

Outline Drawing DPP960

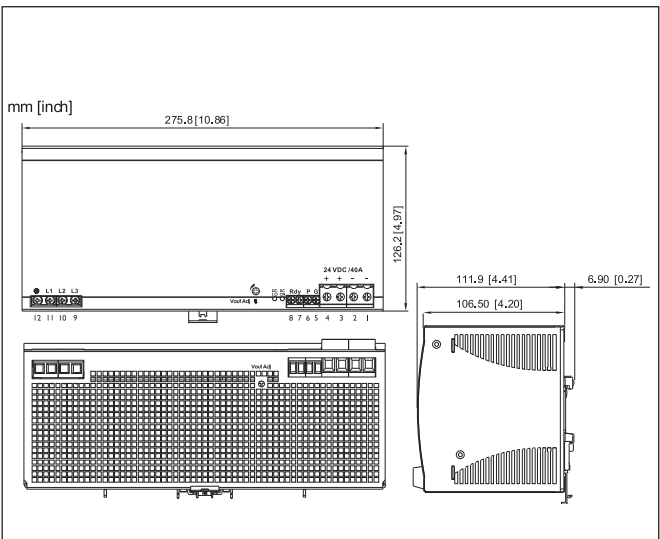

Snap-on Mounting: snap onto DIN Rail TS35/7.5 or TS35/15. (no tools required)



- Single and dual output
- 2:1 and 4:1 Input Ranges
- Meet EN55022 Class B
- Input fuse protection
- Input reverse polarity protection
- Overload and short circuit protection
- Over voltage protection
- Reliable snap-on for DIN rail TS-35/7.5 or TS-35/15
- I/O-isolation 1600 VDC
- Output DC-OK indicator

DPX Series

15 - 60W Din Rail Mount DC-DC Converters

Key Market Segments & Applications

Communication Systems, Industry Control Systems
Factory Automation, Semiconductor Equipment

The DPX Series offers a very broad range of DC/DC converters suitable for DIN-Rail mounting. The DPX DIN-Rail power supplies are available with a choice of output voltages from 3.3 to ± 15 V. There are 5 power levels starting from 15 W up to 60 W with input voltages from 9.5 to 75 V offering a convenient solution for additional DIN-Rail mounted auxiliary voltages. A narrow 25 mm rugged metal case takes up minimal DIN-Rail space.

Model Selector

Model DPX15	Input Range	Output Voltage	Output Current Min Load	Output Current Full Load
DPX15-24WS3P3	9.5 - 36 VDC	3.3 VDC	0mA	4500mA
DPX15-24WS05	9.5 - 36 VDC	5 VDC	0mA	3000mA
DPX15-24WS5P1	9.5 - 36 VDC	5.1 VDC	0mA	3000mA
DPX15-24WS12	9.5 - 36 VDC	12 VDC	0mA	1250mA
DPX15-24WS15	9.5 - 36 VDC	15 VDC	0mA	1000mA
DPX15-24WD05	9.5 - 36 VDC	± 5 VDC	0mA	± 1500 mA
DPX15-24WD12	9.5 - 36 VDC	± 12 VDC	0mA	± 625 mA
DPX15-24WD15	9.5 - 36 VDC	± 15 VDC	0mA	± 500 mA
DPX15-48WS3P3	18 - 75 VDC	3.3 VDC	0mA	4500mA
DPX15-48WS05	18 - 75 VDC	5 VDC	0mA	3000mA
DPX15-48WS5P1	18 - 75 VDC	5.1 VDC	0mA	3000mA
DPX15-48WS12	18 - 75 VDC	12 VDC	0mA	1250mA
DPX15-48WS15	18 - 75 VDC	15 VDC	0mA	1000mA
DPX15-48WD05	18 - 75 VDC	± 5 VDC	0mA	± 1500 mA
DPX15-48WD12	18 - 75 VDC	± 12 VDC	0mA	± 625 mA
DPX15-48WD15	18 - 75 VDC	± 15 VDC	0mA	± 500 mA



Model Selector

Model DPX20	Input Range	Output Voltage	Output Current Min Load	Output Current Full Load
DPX20-24WS3P3	9.5 - 36 VDC	3.3 VDC	0mA	5500mA
DPX20-24WS05	9.5 - 36 VDC	5 VDC	0mA	4000mA
DPX20-24WS12	9.5 - 36 VDC	12 VDC	0mA	1670mA
DPX20-24WS15	9.5 - 36 VDC	15 VDC	0mA	1330mA
DPX20-24WD05	9.5 - 36 VDC	±5 VDC	0mA	±2000mA
DPX20-24WD12	9.5 - 36 VDC	±12 VDC	0mA	±833mA
DPX20-24WD15	9.5 - 36 VDC	±15 VDC	0mA	±667mA
DPX20-48WS3P3	18 - 75 VDC	3.3 VDC	0mA	5500mA
DPX20-48WS05	18 - 75 VDC	5 VDC	0mA	4000mA
DPX20-48WS12	18 - 75 VDC	12 VDC	0mA	1670mA
DPX20-48WS15	18 - 75 VDC	15 VDC	0mA	1330mA
DPX20-48WD05	18 - 75 VDC	±5 VDC	0mA	±2000mA
DPX20-48WD12	18 - 75 VDC	±12 VDC	0mA	±833mA
DPX20-48WD15	18 - 75 VDC	±15 VDC	0mA	±667mA
Model DPX 30				
DPX30-24WS3P3	10 - 40 VDC	3.3 VDC	0mA	6000mA
DPX30-24WS05	9.5 - 36 VDC	5 VDC	0mA	6000mA
DPX30-24WS12	10 - 40 VDC	12 VDC	0mA	2500mA
DPX30-24WS15	10 - 40 VDC	15 VDC	0mA	2000mA
DPX30-24WD12	10 - 40 VDC	±12 VDC	0mA	±1250mA
DPX30-24WD15	10 - 40 VDC	±15 VDC	0mA	±1000mA
DPX30-48WS3P3	18 - 75 VDC	3.3 VDC	0mA	6000mA
DPX30-48WS05	18 - 75 VDC	5 VDC	0mA	6000mA
DPX30-48WS12	18 - 75 VDC	12 VDC	0mA	2500mA
DPX30-48WS15	18 - 75 VDC	15 VDC	0mA	2000mA
DPX30-48WD12	18 - 75 VDC	±12 VDC	0mA	±1250mA
DPX30-48WD15	18 - 75 VDC	±15 VDC	0mA	±1000mA



Model Selector				
Model DPX40	Input Range	Output Voltage	Output Current Min Load	Output Current Full Load
DPX40-24WS3P3	9.5 - 36 VDC	3.3 VDC	0mA	10000mA
DPX40-24WS05	9.5 - 36 VDC	5 VDC	0mA	8000mA
DPX40-24WS12	9.5 - 36 VDC	12 VDC	50mA	3333mA
DPX40-24WS15	9.5 - 36 VDC	15 VDC	50mA	2666mA
DPX40-24WD12	9.5 - 36 VDC	±12 VDC	±65mA	±1667 mA
DPX40-24WD15	9.5 - 36 VDC	±15 VDC	±50mA	±1333mA
DPX40-48WS3P3	18 - 75 VDC	3.3 VDC	0mA	1000mA
DPX40-48WS05	18 - 75 VDC	5 VDC	0mA	8000mA
DPX40-48WS12	18 - 75 VDC	12 VDC	50mA	3333mA
DPX40-48WS15	18 - 75 VDC	15 VDC	50mA	2666mA
DPX40-48WD12	18 - 75 VDC	±12 VDC	±65mA	±1667mA
DPX40-48WD15	18 - 75 VDC	±15 VDC	±60mA	±1333mA
DPX40 Triple Output				
DPX40-12T3312	9.5 - 18 VDC	3.3 ±12VDC	600mA ±40mA	6000mA ±400mA
DPX40-12T3315	9.5 - 18 VDC	3.3 ±15VDC	600mA ±30mA	6000mA ±300mA
DPX40-12T0512	9.5 - 18 VDC	5.0 ±12VDC	600mA ±40mA	6000mA ±400mA
DPX40-12T0512	9.5 - 18 VDC	5.0 ±15VDC	600mA ±30mA	6000mA ±300mA
DPX40-24T3312	18 - 36 VDC	3.3 ±12VDC	600mA ±40mA	6000mA ±400mA
DPX40-24T3315	18 - 36 VDC	3.3 ±15VDC	600mA ±30mA	6000mA ±300mA
DPX40-24T0512	18 - 36 VDC	5.0 ±12VDC	600mA ±40mA	6000mA ±400mA
DPX40-24T0515	18 - 36 VDC	5.0 ±15VDC	600mA ±30mA	6000mA ±300mA
DPX40-48T3312	36 - 75 VDC	3.3 ±12VDC	600mA ±40mA	6000mA ±400mA
DPX40-48T3315	36 - 75 VDC	3.3 ±15VDC	600mA ±30mA	6000mA ±300mA
DPX40-48T0512	36 - 75 VDC	5.0 ±12VDC	600mA ±40mA	6000mA ±400mA
DPX40-48T0515	36 - 75 VDC	5.0 ±15VDC	600mA ±30mA	6000mA ±300mA
DPX60				
DPX60-24S3P3	18 - 36 VDC	3.3 VDC	0mA	14000mA
DPX60-24S05	18 - 36 VDC	5 VDC	0mA	12000mA
DPX60-24S12	18 - 36 VDC	12 VDC	0mA	5000mA
DPX60-24S15	18 - 36 VDC	15 VDC	0mA	4000mA
DPX60-48S3P3	36 -75 VDC	3.3 VDC	0mA	14000mA
DPX60-48S05	36 -75 VDC	5 VDC	0mA	12000mA
DPX60-48S12	36 -75 VDC	12 VDC	0mA	5000mA
DPX60-48S15	36 -75 VDC	15 VDC	0mA	4000mA

For full data and drawings please visit
www.emea.tdk-lambda.com/dpx



Outline Drawing DPX20W Series

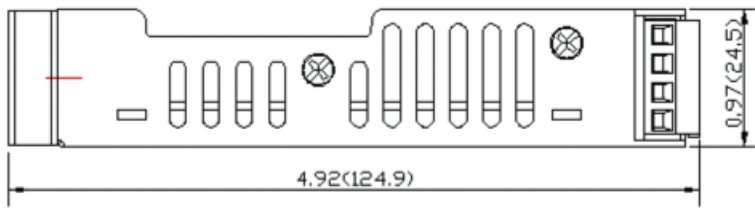
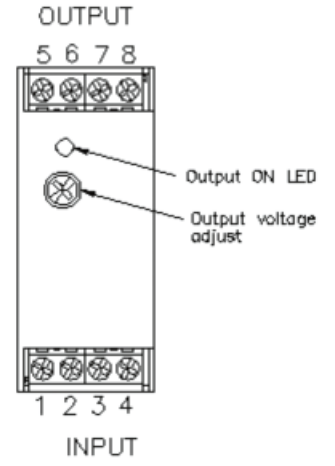
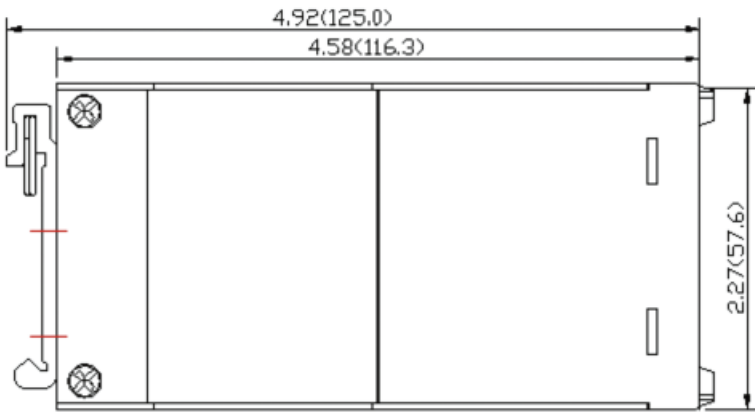

All dimensions in inches (mm)
Tolerance: X.XX ± 0.04 (X.X±1.0)
X.XXX± 0.02 (X.XX±0.5)



Hot Swap Front End AC-DC Power Supplies

Ideal for any application utilising distributed power architecture or requiring hotswap pluggable ac-dc power supplies. 12V, 24V, 32V and 48V models are available as well as 1U racks with split outputs for applications other than standard parallel bulk power connection. The HFE range offers high reliability, high efficiency and high power density with up to 10kW possible in a 1U rack and has a PMBus interface option. Flexible control over output voltage and current limit is possible. These products are widely used in broadcast transmitters, industrial lasers, LED display systems and in the oil and gas industry.



FPS1000 Series 864 -1008W Single Output

Page No.

157



HFE1600/2500 Series 1584W - 2500W Single Output

160



- 1U High
- Up to 3000W (3 units) in 19" Rack
- Hotswap capable (Oring Diodes Built In)
- Low Cost
- PoE Option

FPS1000 Series

1000W Front End
Power Supplies

Key Market Segments & Applications

Power for Distributed Power Architecture
Factory Automation
RF Amplifiers

FPS Features and Benefits

Features

- 1U High
- Hotswap capable
- High Efficiency
- Full Array of Signals

Benefits

- Lower Cost of Ownership
- Suitable for N+1 Redundancy
- Less Heat Dissipated in System
- Easier System Monitoring

Specifications

ITEMS	MODELS	NOMINAL			
		12V Nominal	24V Nominal	32V Nominal	48V Nominal
Output Voltage Range	(1) V	10.5 - 13.2V	21.5 - 29V	28.8 - 38.4V	43 - 58V
Output Current	A	72A	40A	31A	21A
Line Regulation	-	<0.4%			
Load Regulation	-	<0.8%			
Output Noise	mV	150mV	200mV	250mV	300mV
Overvoltage Protection	V	14.3 to 15.7V	31 to 34V	41.5V to 45.5V	62 to 66V
Overcurrent Protection	-	105 - 125%, Constant Current type			
Load Sharing	-	Single wire current sharing, up to 8 units			
Remote Sense	-	Compensates for 1V on each output lead			
I ² C Monitoring	-	Optional (Specify /S)			
Signals (opto isolated)	-	DC OK, AC Fail, and Over temperature warning, high on fail			
Remote On/Off	-	On: 0 - 0.6V or short, Off: 2- 15V or open			
Auxiliary Output	-	11.2-12.5VDC 0.25A			
AC Input	(2)	85 - 265VAC, 47 - 63Hz ² , 120-360VDC. (Derate 10% < 100VAC)			
Leakage Current	mA	<1.1mA at 230VAC input			
Inrush Current	A	<40A			
Hold up time (100VAC input)	-	20ms typical (at 80% rated load)			
Efficiency (typ) 100/200VAC	-	81 / 83%	84 / 86%	84 / 86%	85 / 88%
Power Factor Correction	-	EN61000-3-2 class A (20-100% load), >0.98 at full load			
Immunity	-	EN61000-4-2, -3, -4, -5, -6, -11			
EMC (conducted and radiated)	-	EN55022, level B, FCC Class B			
Operating Temperature	°C	0°C to +70°C, derate 2%/°C from 50°C to 60°C, 2.5%/°C from 60°C to 70°C			
Storage Temperature	°C	-30°C to +85°C			
Withstand Voltage	-	Input to Output 3kVAC, Input to Ground 2kVAC, Output to Ground 500VAC for 1 min.			
Cooling	-	Two internal fans, airflow from front to back (variable speed)			
Humidity	-	Operating: 10 - 90% RH, Storage: 10 - 95% RH (non condensing)			
Shock & Vibration	-	Built to meet ETS 300 019			
Safety Agency	-	UL60950-1, EN60950-1, CE Mark			
Input / Output Connector	-	Positronic PCIB24W9M400A1 (Mating #PCIB24W9F400A1)			
Front panel indicators	-	AC OK, DC OK, DC Fail			
Size (HxWxL)	mm	Stand alone: 41 x 127 x 290; Rack: 44 x 400 x 351			
Weight	g	2,000			
Warranty	yr	2			

Note 1 Via Trim pin on output connector

Note 2 47-440Hz with reduced PFC (100-265VAC)



Model Selector

Front AC Input Panel Configuration	Output Voltage	Output Current	Max Power	I ² C Interface
FPS100012/P	12V	72A	864W	No
FPS100012/PS	12V	72A	864W	Yes
FPS100024/P	24V	40A	960W	No
FPS100024/PS	24V	40A	960W	Yes
FPS100032/P	32V	31A	992W	No
FPS100032/PS	32V	31A	992W	Yes
FPS100048/P	48V	21A	1008W	No
FPS100048/PS	48V	21A	1008W	Yes
FPSS1U/P	Rack (3 slot), contains two blanking panels			
FPST1U/P	Rack with 3 individual outputs (floating)			

Rear AC Input Panel Configuration	Output Voltage	Output Current	Max Power	I ² C Interface
FPS100012	12V	72A	864W	No
FPS100012/S	12V	72A	864W	Yes
FPS100024	24V	40A	960W	No
FPS100024/S	24V	40A	960W	Yes
FPS100032	32V	31A	992W	No
FPS100032/S	32V	31A	992W	Yes
FPS100048	48V	21A	1008W	No
FPS100048/S	48V	21A	1008W	Yes
FPSS1U	Rack (3 slot), contains two blanking panels			
FPST1U	Rack with 3 individual outputs (floating)			

Options

Suffix	Description
/POE*	1500VAC Output to Ground Isolation (output noise 400mV)
*FPS100048 only	

Full System (3 Modules & FPS s1U rack)

FPS3000 -	XX	/ X	
	12	BLANK	= Standard
	24	S	= I ² C
	32	P	= FRONT AC INPUT
	48		

Outline Drawing FPS1000 Series

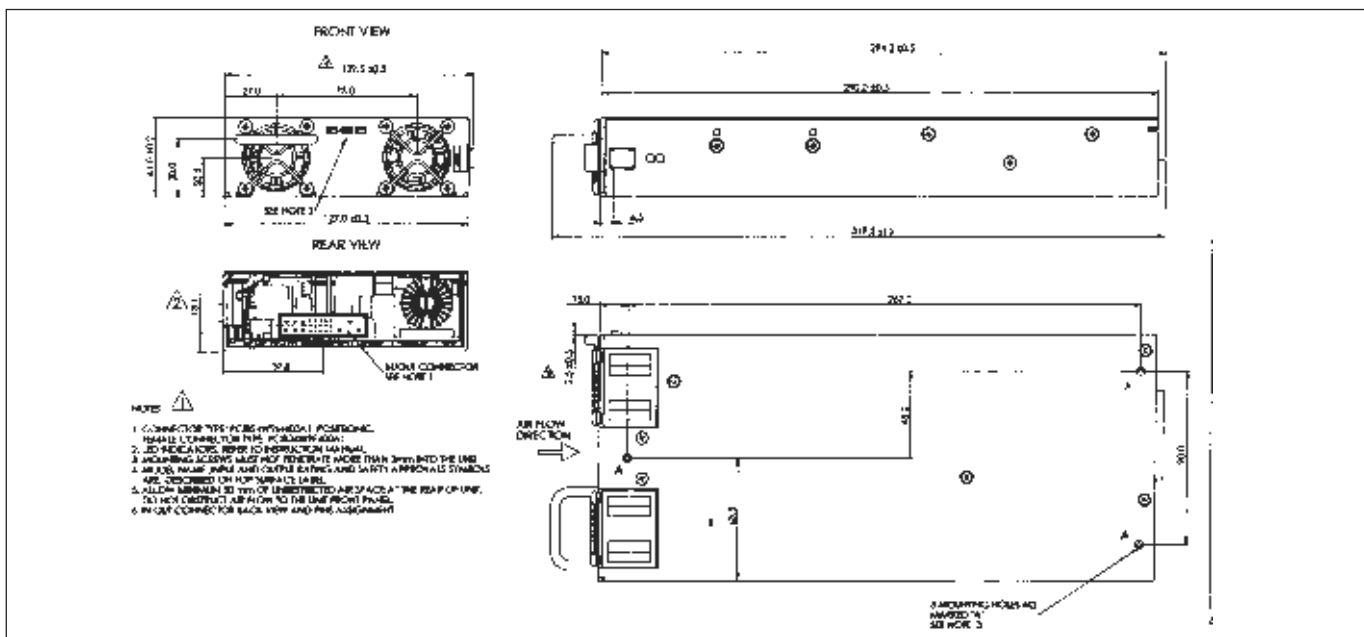



Outline Drawing FPS1000/P Series

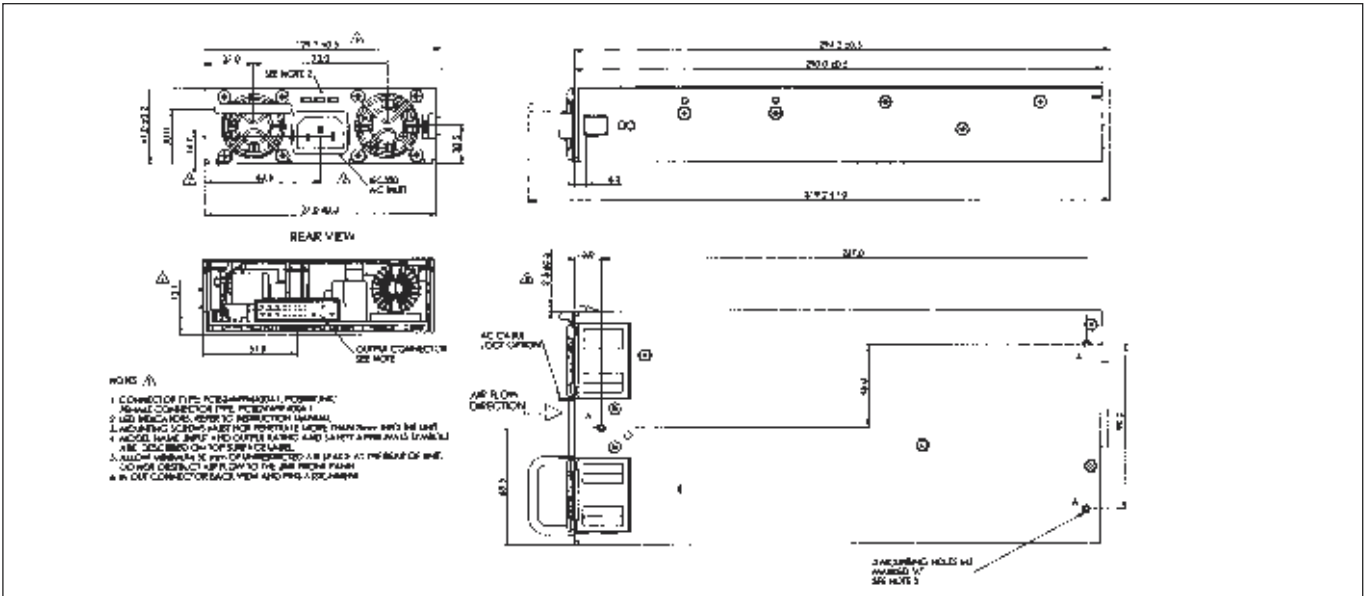

Outline Drawing FPS Racks

FPST1U Rear View

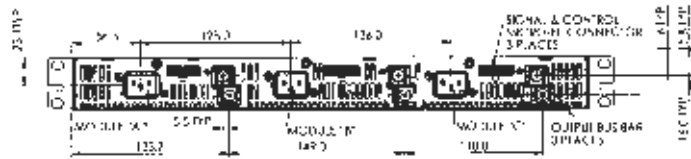

FPSS1U

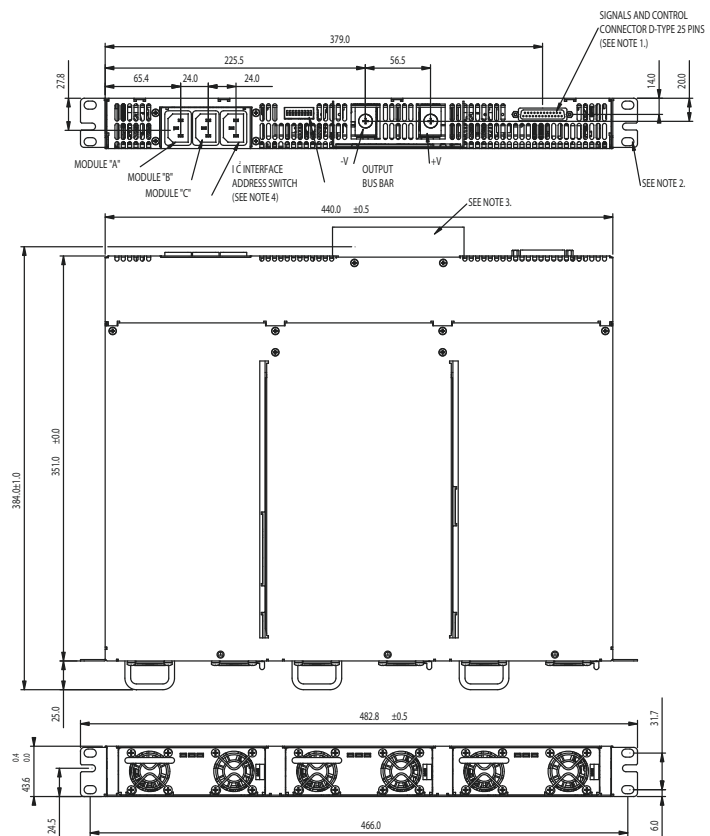



- 25.2W/in³ power density
- Internal ORing MOSFET & Current Share
- Climate Savers Computing efficiency standards
- Up to 8000W in 1U rack
- Status monitoring signals
- PMBus option



HFE1600 Series

1600W 1U Hot Swap Front End Power Supplies

Key Market Segments & Applications

Power for Distributed Power Architecture
Industrial Automation

HFE1600 Features and Benefits

Features

- 1U high
- Internal ORing MOSFET & Current Share
- Status monitoring signals

Benefits

- Utilizes less system space
- Suitable for N+1 redundancy
- Easier system monitoring including PMBus

Specifications

ITEMS	MODELS		
	(2)	VAC	
Input Voltage Range	(2)	VAC	85 - 265VAC, 47 - 63Hz. See model selector for power derating
Input Current (Max) 100/230VAC		A	14.2 / 8.1A
Inrush Current		A	<35A
Power Factor Correction		-	Meets EN61000-3-2, PF > 0.98 at full load
Temperature Coefficient		%/°C	<0.02%/°C
Overcurrent Protection		%	105 - 120%. Programmable by external voltage (0-5V)
Overvoltage Protection	(1)	%	115% (Tracking). Cycle AC to reset or utilize Remote On/Off
Overtemperature Protection	(1)	-	Shutdown with automatic restart. Warning signal provided
Hold up time		ms	>10ms, 100/230VAC Input, 80% loading
Leakage Current		mA	< 0.75 / 1.5mA 100/230VAC, 60Hz
Remote Sense Compensation		-	HFE1600-12: 0.5V/wire, HFE1600-24, -48: 1V/wire
Indicators		-	AC OK: Green LED, DC OK / Fail: Green / Red LED
Remote On/Off		-	Unit ON: 0 - 0.6V or short, OFF: 2 - 15V or open circuit
Parallel Operation		-	Yes, single wire current share, 90% accuracy, up to 10 units
AC Fail Signal		-	Open Collector, ON when AC is within 85 - 270VAC
DC Good Signal		-	Open Collector, ON when output is above 85 to 95% of setpoint (tracking)
Remote Adjust	(1)	-	By either external 0 - 5V signal or 1k potentiometer
I ² C Interface	(1)	-	Isolated from output, Add suffix /S, PMBus compatible
Auxiliary Output		-	11.2 - 12.5V, 0.5A, 240mV ripple and noise
Operating Temp. (-TB Rack)		°C	-10°C to +70°C, derate 2%/°C from 50°C to 60°C, 2.5%/°C from 60°C to 70°C
Operating Temp. (-IEC320 Rack)		°C	-10°C to +60°C, derate 2%/°C from 50°C to 60°C
Storage Temperature		°C	-30°C to +85°C
Humidity (Non condensing)		%RH	Operating: 10 - 90%RH, Storage: 10 - 95%RH
Cooling		-	Two variable speed internal fans, airflow exits across input/output connector
Withstand Voltage		-	I/P to O/P 3kVAC, I/P to Ground 2kVAC, O/P to Ground: HFE1600-12, -24V 500VAC, HFE1600-48 1.5kVAC
Isolation Resistance		Ω	>100MΩ at 25°C & 70%RH, Output to Ground 500VDC
Vibration (Basic transportation)		-	Meets IEC61068-2-64
Shock (Basic transportation)		-	Meets IEC61068-2-27
Safety Agency Certifications		-	UL60950-1, EN60950-1, CE Mark
Conducted and Radiated EMI		-	EN55022 & FCC part 15; Conducted class B, Radiated class A
Immunity		-	IEC61000-4-2 (lv 2,3), -3 (lv 2), -4 (lv2), -5 (lv3,4), -6 (lv2), -8 (lv 4), -11
Size (W x H x D)		mm	Power Supply: 85 x 41 x 300, Rack: 445 x 44 x 365
Weight		g	Power Supply: 1550g, Rack: 4800g
Warranty		yrs	3

(1) See installation manual for detailed specifications & test methods

(2) Derate output power linearly 1%/V from 100VAC to 85VAC input



Model Selector

Model	Output Voltage	Adjust Range (1)	Max Current (Vin>170VAC)(2)	Max Power (Vin>170VAC)(2)	Max Current (100<Vin<170VAC)(2)	Max Power (100<Vin<170VAC)(2)
HFE1600-12	12V	9.6 - 13.2V	133A	1596W	100A	1200W
HFE1600-12/S	12V	9.6 - 13.2V	133A	1596W	100A	1200W
HFE1600-24	24V	19.2 - 29V	67A	1608W	50A	1200W
HFE1600-24/S	24V	19.2 - 29V	67A	1608W	50A	1200W
HFE1600-48	48V	38.4 - 58V	33A	1584W	25A	1200W
HFE1600-48/S	48V	38.4 - 58V	33A	1584W	25A	1200W

Model	Load Reg	Line Reg	Ripple & Noise	Efficiency (%) ⁽³⁾	PC
HFE1600-12	60mV	30mV	240mV	87 / 90%	-
HFE1600-12/S	60mV	30mV	240mV	87 / 90%	Yes
HFE1600-24	120mV	60mV	240mV	88 / 90%	-
HFE1600-24/S	120mV	60mV	240mV	88 / 90%	Yes
HFE1600-48	240mV	120mV	480mV	89 / 92%	-
HFE1600-48/S	240mV	120mV	480mV	89 / 92%	Yes

(3) At 75% load, 100 / 230VAC input

- HFE2500 high power density 1U hotswap front end 29W/cu in • 12, 24 or 48 V models • Up to 4 units in a 1U 19" rack •
- 10 kW output power per rack (2 racks can be paralleled for 20kW) •

Available early 2011

Rack Model Selector

Model	Description	Maximum Rack Current
HFE1600-S1U	Five slot 19" rack, IEC320 input connectors (5)	200A each side (400A total)
HFE1600-S1U-TB	Five slot 19" rack, Terminal Block input connectors (5)	200A each side (400A total)
HFE1600/BP	One slot blanking panel, three provided with each rack	

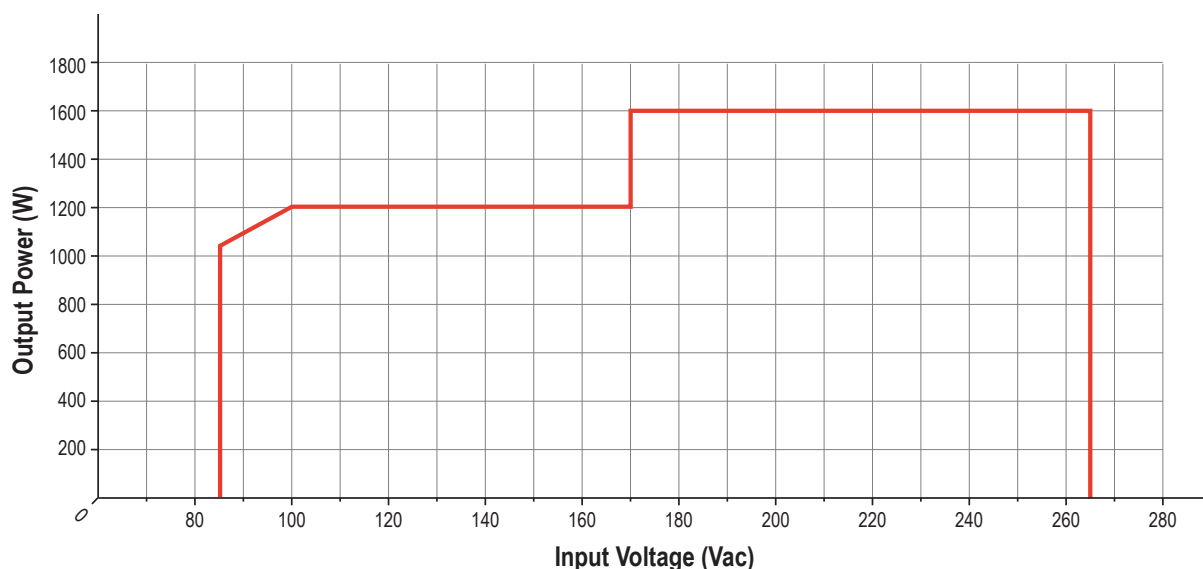

HFE 1600 Power Derating v's Input Voltage



Outline Drawing HFE1600 Series

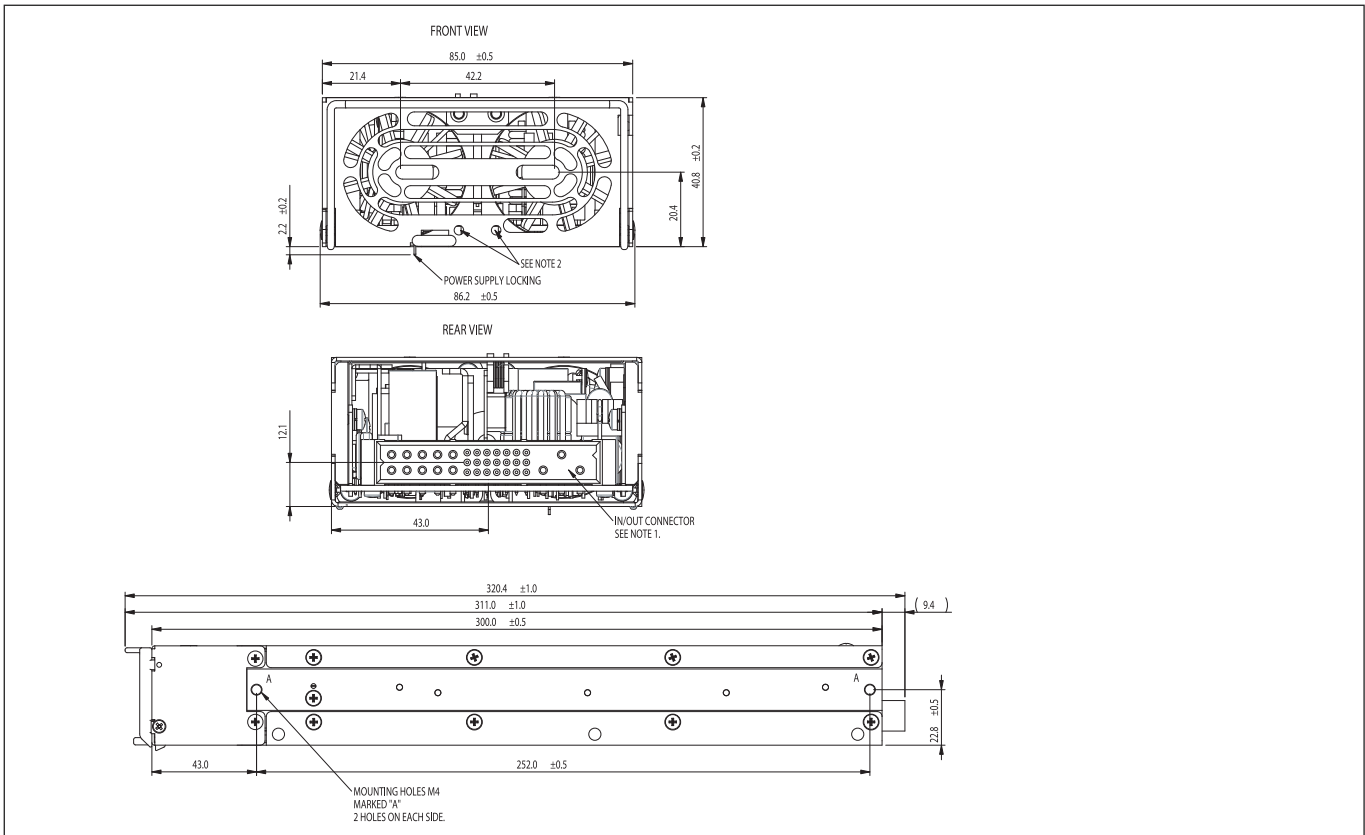

Outline Drawing HFE1600S1U Series

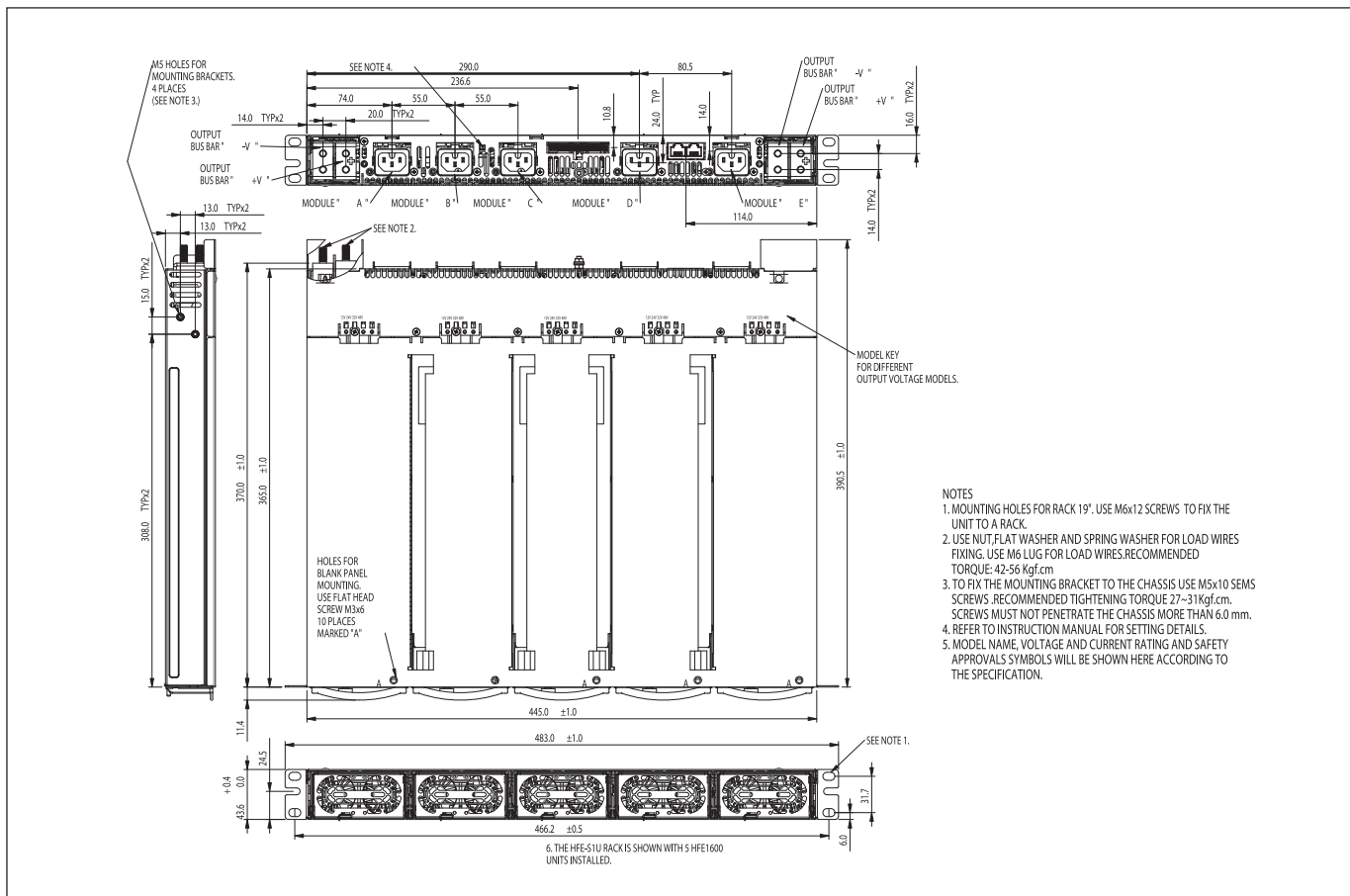



LED Lighting Constant Voltage and Constant Current AC-DC Power Supplies

The ALV constant voltage and ALC constant current LED lighting power supplies are IP66 splash proof rated and are ideal for indoor and outdoor installations. They are designed for long service life to match the expected lifetime of the LED lighting fixture itself. Available now in 12W output power with 60W, 80W and 100W models due for launch in Spring 2011.

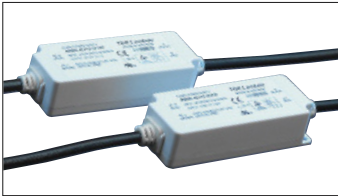

ALC/ALV Series 12W Single Output

Page No.

164

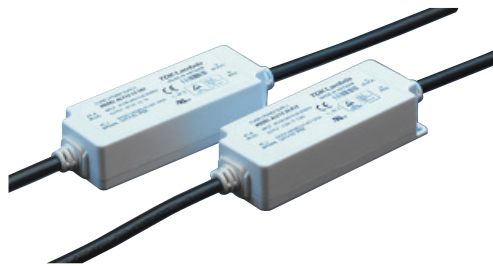

- Small Size
- Constant Current or Constant Voltage Versions
- Splash proof
- Conservative component ratings for long life

Key Market Segments & Applications

- LED Lighting
- Damp Environments

ALC/ALV Series

12W IP66
Power Supplies

AL12 Features and Benefits

Features

- IP66 Rated
- Vacuum Encapsulated
- Wide range AC Input

Benefits

- Can be used in wet applications
- Robust
- Supports global use

Specifications

MODEL		ALC12	ALV12
ITEMS			
AC Input	VAC/Hz	90 - 264VAC, 47 - 63Hz	
Inrush Current (100/200VAC)	A	25 / 50A, 25°C ambient, cold start	
Input Current (110/200VAC)	A	0.28 / 0.18A	
Temperature Coefficient	-	<0.02%/°C (0 - 50°C)	
Overcurrent Protection	-	Automatic Recovery	> 105% of rated power
Overvoltage Protection	%	> 110%	
Turn on time	ms	< 200ms	
Leakage Current (265VAC 60Hz)	mA	0.25mA	
Efficiency	%	82% typical at full load	
Operating Temperature	-	-10 to +60°C (Guaranteed start up at -20°C)	
Storage Temperature	-	-30°C to +85°C	
Operating Humidity (1)	-	15 - 90% RH	
Storage Humidity (1)	-	15 - 90% RH	
Cooling	-	Convection	
Withstand Voltage	-	Input to Output 3kVAC (Class II, no ground connection needed)	
Isolation Resistance	Ω	>100MΩ at 25°C & 70%RH, Input to Output at 500VDC	
Vibration (non operating)	-	10 - 55Hz: 19.6m/s ² constant sweep 1 min X, Y, Z for 30 mins	
Shock	-	< 196.1 m/s ² (20G)	
Immunity	-	IEC61000-4-2, -3, -4, -5, -6, -8, -11	
Safety Agency Approvals	-	UL8750 (Class 2), EN61347-1, EN61347-2-13, CSA C22.2 No. 60950-1, CE Mark	
Conducted & Radiated EMI	-	EN55015, EN55022, FCC Class B	
IP Class	-	IP66	
Weight (Typ)	g	84	
Size (LxWxH)	mm	90 x 34.5 x 21	
Warranty	yrs	3	

(1) Non condensing

60, 80 & 100W models coming soon - available early 2011



Model Selector

Model	CV/CC	Output Voltage (V)	Output Accuracy	Min. Output Current (A)	Output Current (A)	Maximum Average Power	Ripple & Noise
ALC12-36-R35	CC	3 - 36V	0.33 - 0.37A	-	0.35A	12.6W	-
ALC12-18-R70	CC	3 - 18V	0.66 - 0.735A	-	0.7A	12.6W	-
ALV12-12-1R0	CV	12	11.4 - 12.6V	0.1A	1A	12W	100mV
ALV12-15-R80	CV	15	14.25 - 15.75V	0.08A	0.8A	12W	100mV
ALV12-24-R50	CV	24	22.8 - 25.2V	0.05A	0.5A	12W	150mV

Outline Drawing AL12 Series

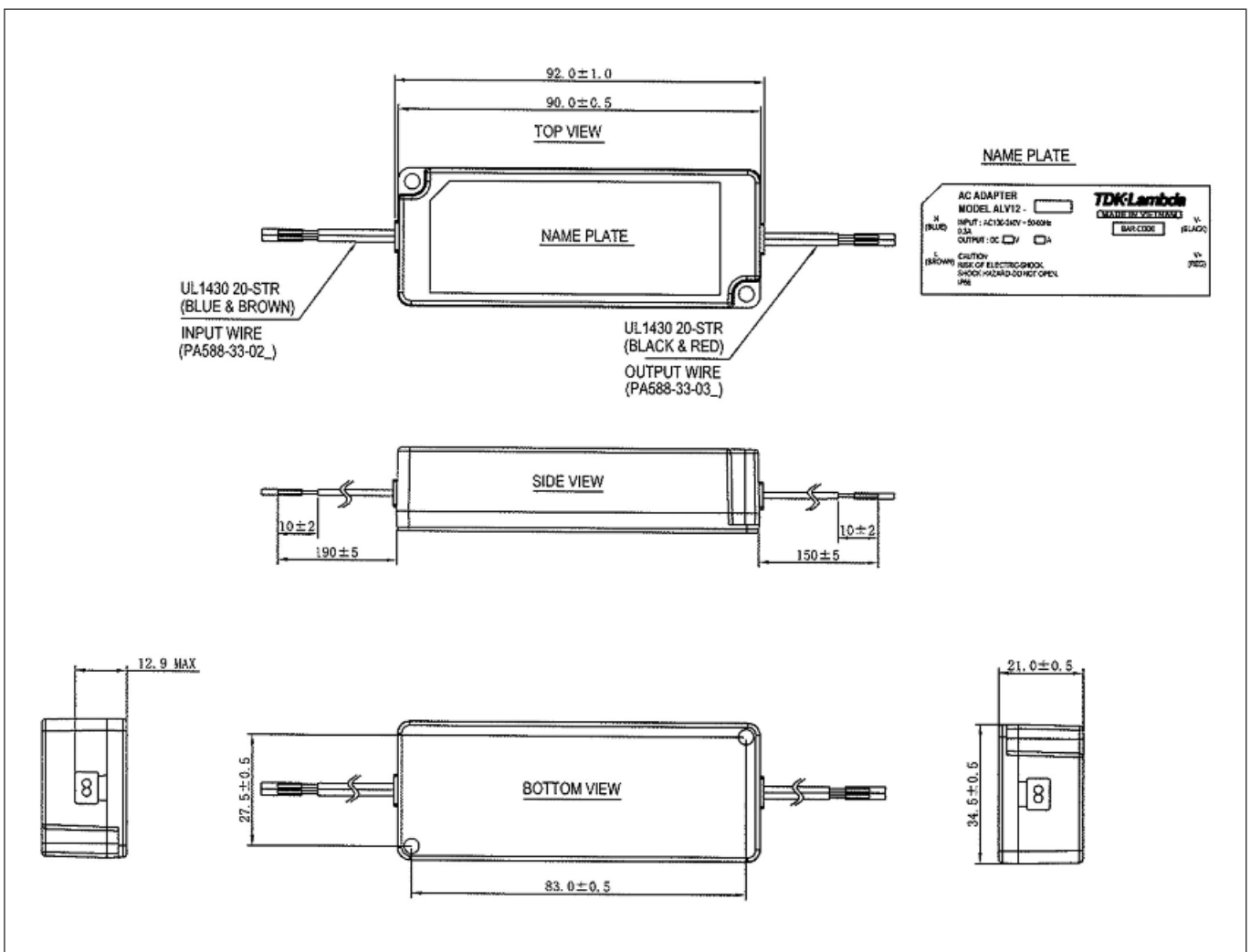



Programmable Rack Mount and Laboratory Power Supplies

Genesys™ and ZUP constant voltage / constant current programmable power supplies are available in versions from 200W to 15kW. Units can be run in master / slave parallel to facilitate higher powered systems. Comprehensive analogue and digital control features come as standard along with free downloadable software and drivers from our website.

Genesys™ has many additional options available such as LAN LXI and GPIB interfaces, power sink and special “fast speed” models optimized for laser diodes and automotive test programmes.

Applications cover many industries including ATE test and component burn-in systems, semiconductor and flat panel display manufacturing processes, water purification, ship-borne ROV power, MRI, electroplating, particle accelerators and renewable energy system inverter testing.



Genesys™ Series 600W - 15000W Single Output

Page No.

168



ZUP Series 200W - 860W Single Output

172



Programmable Power Supplies

Many applications require more than a fixed voltage. Today's test systems and industrial processes require stable and accurate control of output voltage and current during operation with the facility to monitor these parameters.

Genesys™ and ZUP are designed to fulfil these requirements by offering RS-232/RS-485 and analogue control and monitoring interfaces built in as standard. Further options for Genesys™ include LAN (**LXI** compliant) and GPIB (SCPI compliant).

Various software drivers, such as IVI-COM and Labview, and tools are downloadable from our website to enable easy integration with industry standard software control packages.



Applications

Genesys™ and ZUP can provide the best solution for programmable power in many applications by offering comprehensive control and monitoring features that are intuitive and easy to use and not overly complex.

Medical

- X-Ray
- Oncology
- MRI
- Magnets
- Gradient amplifiers

Aerospace & Defence

- RF communication
- Satellite test systems
- Materials research
- ATE systems

Diode Laser

- Medica
- Marking
- Cutting
- Welding

Automotive

- Component burn-in
- Fuel cell
- Lamp testing
- Component development
- Battery simulation

Semiconductor

- Burn-in
- Deposition
- Ion implantation
- Component lead electroplating
- MBE systems
- MOCVD for LED manufacture
- Solar cell manufacture

Test & Measurement

- Large ATE systems
- Component test
- Analytical instrument
- Module and component burn-in
- Solar inverter testing

Other Industrial

- Water purification
- Plating and etching
- Capacitor forming
- Shipborne DC power
- High power halogen heaters
- Flat panel display manufacture



Genesys™

The Genesys™ family of programmable power supplies sets a new standard for flexible, reliable, AC/DC power systems in OEM, Industrial and Laboratory applications.

Features

- **High Power Density**
 - 750W / 1500W / 2400 W in 1 U – 3.3 / 5 kW in 2 U
 - 750 W in 9.5" 1 U – 10 / 15 kW in 3 U
- **Wide Range of popular worldwide AC inputs**
 - 1-phase wide range (85 – 265 V AC)
 - 1-phase (230 V AC)
 - 3-phase (208 V AC, 400 V AC, 480 V AC) model dependent
- **Active/passive Power Factor Correction**
(Single-Phase & Three-Phase AC Input)
- **Output Voltage up to 600 V, Current up to 1000 A**
- **Built-in RS-232 / RS-485 Interface Standard**
- **Global Commands for Serial RS-232 / RS-485 Interface**
- **Auto-Re-Start / Safe-Start: user-selectable**
- **Last-Setting Memory; Front panel lockout**
- **High Resolution 16 bit ADCs & DACs**
- **Low Ripple & Noise**
- **Front Panel Lock selectable from Front Panel or Software**
- **Reliable Encoders for Voltage and Current Adjustment**
- **Constant Voltage / Constant Current auto-crossover**
- **NEW Integrated Power Sink Option for 1U 750W & 1500W Models – up to 60V**

- **Parallel Operation with Active Current Sharing;**
up to four identical units
- **Advanced Parallel Master/Slave**
Total Current is programmed and measured via the master
- **Independent Remote ON/OFF and Remote Enable /Disable**
- **External Analog Programming and Monitoring**
(user-selectable 0 – 5 V & 0 –10 V)
- **Programmable foldback delay for current limit**
- **Auxiliary output 5 V/0.2 A isolated, 15 V/0.2 A non isolated (GEN 2.4 kW only)**
- **Reliable Modular and SMT Design**
- **19" Rack Mount capability for ATE and OEM applications**
- **Optional Interfaces**
 - Isolated Analog Programming and Monitoring Interface (0 – 5 V / 0 –10 V & 4 – 20 mA)
 - IEEE 488.2 SCPI (GPIB) Multi-Drop
 - **LXI** compliant LAN interface
- **LabView™ Genesys™ Control (Runtime Module) and Drivers**
- **Five Years Warranty**

Worldwide Safety Agency Approvals; CE Mark for LVD and EMC Regulation.



Genesys™ 750 / 1500W in 1U with Power Sink

The market leading Genesys™ Programmable Power Supplies offer a wide variety of useful inte-grated functions and features, making them into an extremely effective and easy to use tool for many applications. Now Genesys™ 1 U 750 W and 1500 W models are available with a Power Sink Option (PSINK) that can absorb energy from the load.





Genesys™ LAN 2.0 Interface

The optional LAN Interface for Genesys™ power supplies has been upgraded to provide many new features including functionality for users outside of Test and Measurement. We now offer TCP and UDP networking protocols for alternative operating systems, programming languages and controllers. The option maintains LXI-C Certification.

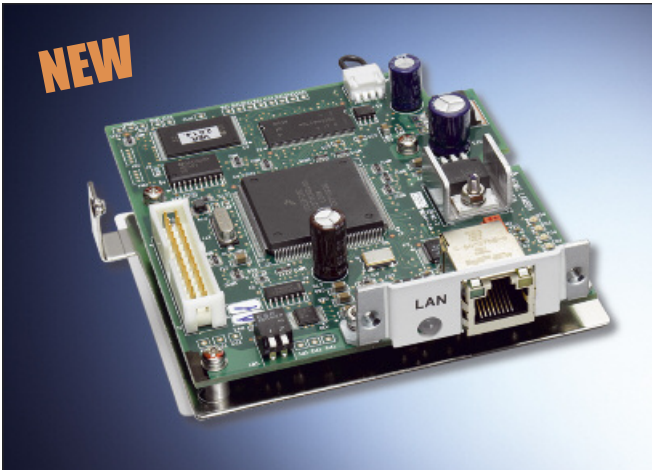

- **Adds TCP and UDP Sockets**
LAN 2.0 expands connectivity for many customers beyond standard test software, operating systems and controllers.
- **Change IP Address using Front Panel Current Encoder**
The current encoder will change the IP address. Locking in a new address requires a confirmation button press, to prevent accidental changes. Address conflicts (duplicate IP) are prevented.

- **The LAN remains LXI-C Certified**
- **Adds Multiple Controllers**
The new LAN allows two or more controller devices to “talk” to the power supply at the same time. The controllers may use any mix of TCP, UDP or VISA protocols.
- **Duplicate IP Recovery**
If the user accidentally sets a duplicate IP address, which is already used by another device, LAN 2.0 will reconnect to the last working address instead of disconnecting from the network. A Front Panel and/or web page alert is posted to the user.
- **Higher Capacity Input Buffer**
The number of commands that may be sent at once has been increased from four to twenty commands.
- **Adds Network Security Setting**
A new security button, on the web page, can be set for “allow only one controller using a secure protocol” or “allow everybody at the same time” to talk to the power supply. (Note: UDP is not a secure protocol, TCP and VISA are secure).
- **Improves Message Terminators**
The traditional terminator for messages is the Line-Feed character. The new LAN 2.0 sockets will accept and return the line-feed.
- **Improved LAN User Manual**
New manual includes specification on command speed. And has an easier to use layout.

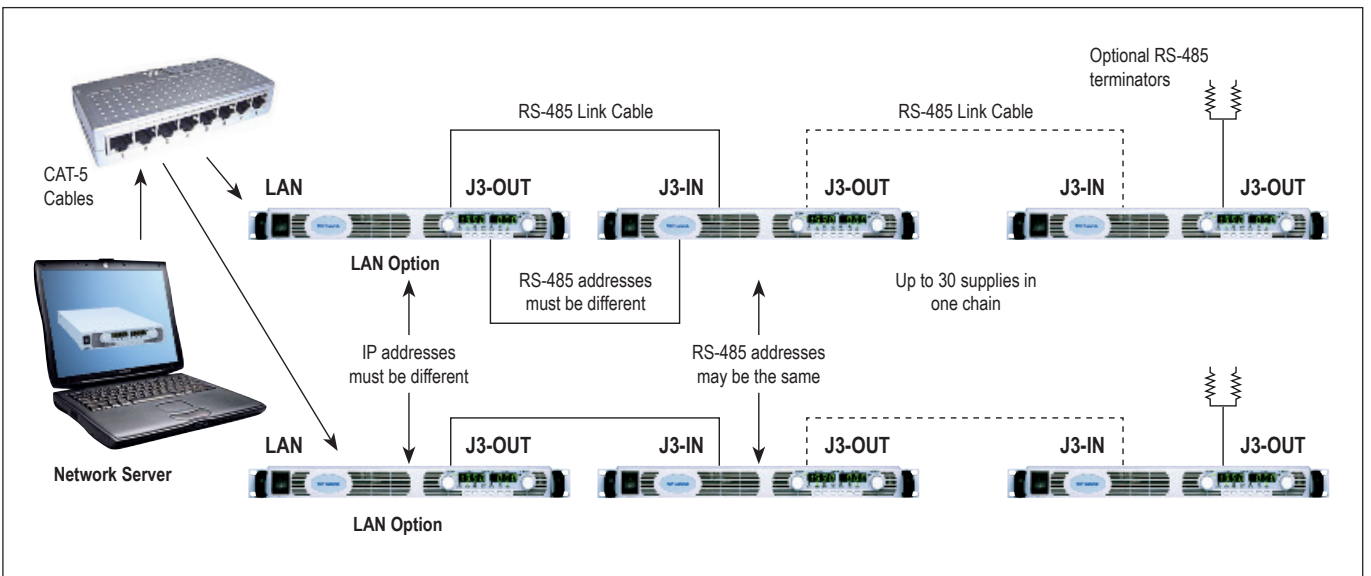



GENH 750 W in 1U Half Rack

Model	Output Voltage V DC	Output Current (A)	Output Power (W)
GENH6-100	0~6 V	0~100 A	600 W
GENH8-90	0~8 V	0~90 A	720 W
GENH12.5-60	0~12.5 V	0~60 A	750 W
GENH20-38	0~20 V	0~38 A	760 W
GENH30-25	0~30 V	0~25 A	750 W
GENH40-19	0~40 V	0~19 A	760 W
GENH60-12.5	0~60 V	0~12.5 A	750 W
GENH80-9.5	0~80 V	0~9.5 A	760 W
GENH100-7.5	0~100 V	0~7.5 A	750 W
GENH150-5	0~150 V	0~5 A	750 W
GENH300-2.5	0~300 V	0~2.5 A	750 W
GENH600-1.3	0~600 V	0~1.3 A	780 W



- Wide Range Input (85 - 265 VAC Continuous)
- Active Power Factor Correction (0.99 typical)
- Output Voltage up to 600V, Current up to 100A

GEN 750/1500/2400 W in 1U 19" Rack

Model	Output Voltage V DC	Output Current (A)	Output Power (W)
GEN6-100	0 ~ 6 V	0 ~ 100 A	600 W
GEN6-200		0 ~ 200 A	1200 W
GEN8-90	0 ~ 8 V	0 ~ 90 A	720 W
GEN8-180		0 ~ 180 A	1440 W
GEN8-300		0 ~ 300 A	2400 W
GEN10-240	0 ~ 10 V	0 ~ 240 A	2400 W
GEN12.5-60	0 ~ 12.5 V	0 ~ 60 A	750 W
GEN12.5-120		0 ~ 120 A	1500 W
GEN16-150	0 ~ 16 V	0 ~ 150 A	2400 W
GEN20-38	0 ~ 20 V	0 ~ 38 A	760 W
GEN20-76		0 ~ 76 A	1520 W
GEN20-120		0 ~ 120 A	2400 W
GEN30-25	0 ~ 30 V	0 ~ 25 A	750 W
GEN30-50		0 ~ 50 A	1500 W
GEN30-80		0 ~ 80 A	2400 W
GEN40-19	0 ~ 40 V	0 ~ 19 A	760 W
GEN40-38		0 ~ 38 A	1520 W
GEN40-60		0 ~ 60 A	2400 W
GEN50-30	0 ~ 50 V	0 ~ 30 A	1500 W
GEN60-12.5	0 ~ 60 V	0 ~ 12.5 A	750 W
GEN60-25		0 ~ 25 A	1500 W
GEN60-40		0 ~ 40 A	2400 W
GEN80-9.5	0 ~ 80 V	0 ~ 9.5 A	760 W
GEN80-19		0 ~ 19 A	1520 W
GEN80-30		0 ~ 30 A	2400 W
GEN100-7.5	0 ~ 100 V	0 ~ 7.5 A	750 W
GEN100-15		0 ~ 15 A	1500 W
GEN100-24		0 ~ 24 A	2400 W
GEN150-5	0 ~ 150 V	0 ~ 5 A	750 W
GEN150-10		0 ~ 10 A	1500 W
GEN150-16		0 ~ 16 A	2400 W
GEN300-2.5	0 ~ 300 V	0 ~ 2.5 A	750 W
GEN300-5		0 ~ 5 A	1500 W
GEN300-8		0 ~ 8 A	2400 W
GEN600-1.3	0 ~ 600 V	0 ~ 1.3 A	780 W
GEN600-2.6		0 ~ 2.6 A	1560 W
GEN600-4		0 ~ 4 A	2400 W



- Highest Power Density available: 2400W in 1U
- Wide Range Input (85 - 265 VAC Continuous, single phase, 47/63Hz) for models up to 1500W.
- Active Power Factor Correction (0.99 typical)
- Output Voltage up to 600V, Current up to 300A
- Power Sink Option for 750W & 1500W.





GEN 3.3/5kW in 2U 19" Rack

Model	Output Voltage V DC	Output Current (A)	Output Power (W)
GEN-8-400	0 ~ 8 V	0 ~ 400 A	3200 W
GEN-8-600		0 ~ 600 A	4800 W
GEN-10-330	0 ~ 10 V	0 ~ 330 A	3300 W
GEN-10-500		0 ~ 500 A	5000 W
GEN-15-220	0 ~ 15 V	0 ~ 220 A	3300 W
GEN-16-310	0 ~ 16 V	0 ~ 310 A	4960 W
GEN-20-165	0 ~ 20 V	0 ~ 165 A	3300 W
GEN-20-250		0 ~ 250 A	5000 W
GEN-30-110	0 ~ 30 V	0 ~ 110 A	3300 W
GEN-30-170		0 ~ 170 A	5100 W
GEN-40-85	0 ~ 40 V	0 ~ 85 A	3400 W
GEN-40-125		0 ~ 125 A	5000 W
GEN-60-55	0 ~ 60 V	0 ~ 55 A	3300 W
GEN-60-85		0 ~ 85 A	5100 W
GEN-80-42	0 ~ 80 V	0 ~ 42 A	3360 W
GEN-80-65		0 ~ 65 A	5200 W
GEN-100-33	0 ~ 100 V	0 ~ 33 A	3300 W
GEN-100-50		0 ~ 50 A	5000 W
GEN-150-22	0 ~ 150 V	0 ~ 22 A	3300 W
GEN-150-34		0 ~ 34 A	5100 W
GEN-200-16.5	0 ~ 200 V	0 ~ 16.5 A	3300 W
GEN-200-25		0 ~ 25 A	5000 W
GEN-300-11	0 ~ 300 V	0 ~ 11 A	3300 W
GEN-300-17		0 ~ 17 A	5100 W
GEN-400-13	0 ~ 400 V	0 ~ 13 A	5200 W
GEN-500-10	0 ~ 500 V	0 ~ 10 A	5000 W
GEN-600-5.5	0 ~ 600 V	0 ~ 5.5 A	3300 W
GEN-600-8.5		0 ~ 8.5 A	5100 W

GEN 10/15kW in 3U 19" Rack

Model	Output Voltage V DC	Output Current (A)	Output Power (W)
GEN-7.5-1000	0 ~ 7.5 V	0 ~ 1000 A	7.5 kW
GEN-10-1000	0 ~ 10 V	0 ~ 1000 A	10 kW
GEN-12.5-800	0 ~ 12.5 V	0 ~ 800 A	10 kW
GEN-20-500	0 ~ 20 V	0 ~ 500 A	10 kW
GEN-25-400	0 ~ 25 V	0 ~ 400 A	10 kW
GEN-30-333	0 ~ 30 V	0 ~ 333 A	10 kW
GEN-40-250	0 ~ 40 V	0 ~ 250 A	10 kW
GEN-50-200	0 ~ 50 V	0 ~ 200 A	10 kW
GEN-60-167	0 ~ 60 V	0 ~ 167 A	10 kW
GEN-60-250		0 ~ 250 A	15 kW
GEN-80-125	0 ~ 80 V	0 ~ 125 A	10 kW
GEN-80-187.5		0 ~ 187.5 A	15 kW
GEN-100-100	0 ~ 100 V	0 ~ 100 A	10 kW
GEN-100-150		0 ~ 150 A	15 kW
GEN-125-80	0 ~ 125 V	0 ~ 80 A	10 kW
GEN-125-120		0 ~ 120 A	15 kW
GEN-150-66	0 ~ 150 V	0 ~ 66 A	10 kW
GEN-150-100		0 ~ 100 A	15 kW
GEN-200-50	0 ~ 200 V	0 ~ 50 A	10 kW
GEN-200-75		0 ~ 75 A	15 kW
GEN-250-40	0 ~ 250 V	0 ~ 40 A	10 kW
GEN-250-60		0 ~ 60 A	15 kW
GEN-300-33	0 ~ 300 V	0 ~ 33 A	10 kW
GEN-300-50		0 ~ 50 A	15 kW
GEN-400-25	0 ~ 400 V	0 ~ 25 A	10 kW
GEN-400-37.5		0 ~ 37.5 A	15 kW
GEN-500-20	0 ~ 500 V	0 ~ 20 A	10 kW
GEN-500-30		0 ~ 30 A	15 kW
GEN-600-17	0 ~ 600 V	0 ~ 17 A	10 kW
GEN-600-25		0 ~ 25 A	15 kW

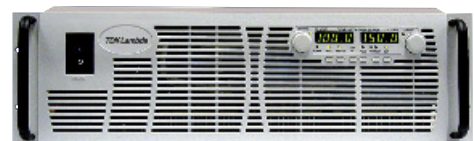

- Highest Power Density 5kW in 2U
- Wide Range of popular worldwide AC inputs, Single-Phase (230VAC) & Three-Phase (208VAC, 400VAC) (5kW only 3 phase)
- Active Power Factor Correction (Single-Phase & Three-Phase AC Input)
- Output Voltage up to 600V, Current up to 600A

- Highest Power Density 10/15kW in 3U
- Wide Range of popular worldwide Three Phase AC Inputs, (208VAC, 400VAC, 480VAC)
- Power Factor 0.88 (Passive Correction on all Inputs)
- Output Voltage up to 600V, Current up to 1,000A



- Constant Voltage / Constant Current
- Last Setting Memory
- Digital Meters
- Built-in RS232 & RS485 Interface w/ GPIB optional
- Bench or Rack Mount
- Embedded Microprocessor Controller
- Voltage up to 120V, Current up to 132A

ZUP Series

Zero Up Programmable Power Supplies

Specifications		ZUP6	ZUP10	ZUP20	ZUP36	ZUP60	ZUP80	ZUP120
ITEMS	MODELS							
	Cond.							
Load Regulation	CV	2mV + 0.005% over 0 - 100% load change						
Line Regulation	CV	1mV + 0.005% over 85 - 132 or 170 - 265VAC constant load						
Recovery Time (1)	CV	1ms	0.5ms	0.2ms				
Temperature Coefficient	CV	30ppm/°C following 30 minute warm up						
Temperature Drift (2)	CV	0.01% + 2mV change in output						
Up programming response time	CV	50 - 60ms					80ms	120ms
Down prog. resp. time (CV)	Full	50ms (70ms ZUP60-14)						
Down prog. resp. time (CV)	Zero	250ms	350ms	400ms	500ms	750ms	800ms	1000ms
Load Regulation	CC	0.01% + 5mA on 200W and 400W models, 0.07% + 10mA on 800W models						
Line Regulation	CC	0.01% + 2mA on 200W and 400W models, 0.01% + 5mA on 800W models						
Temperature Coefficient	CC	100ppm/°C from rated current after 30 minute warm up time						
Temperature Drift (2)	CC	0.02% + 5mA, 200W and 400W models, 0.05% + 10mA, 800W models						
Prog Voltage resolution	-	Better than 0.028% of rated voltage						
Prog Voltage accuracy	-	.02%+5mV.	.02%+8mV.	.02%+12mV	.02%+20mV	.02%+35mV	.02%+50mV	.02%+80mV
Prog Current resolution	-	Better than 0.03% of rated current						
Prog Current accuracy	-	0.4% + 40mA						
Overvoltage Shutdown	V	0 - 7.5	0 - 13	0 - 24	0 - 40	0 - 66	0 - 88	0 - 132
Thermal Protection	-	Over temperature protected						
Display - Voltage	-	3 digits (6, 20, 36, 60, 80V models), 3.5 digits (10, 120V models). Accuracy 0.2% ± 2 digits						
Display - Current	-	3 digits, (3.5 digits 132A model). Accuracy 0.5% ± 3 digits						
Display - Status	-	CV / CC, Alarm, Foldback, Local/Remote, On/Off						
Remote On/Off	-	TTL signal or dry contact relay						
Output Good	-	Open Collector						
Voltage & Current Programming	-	By either Voltage (0-4V) or Resistance (0-4k)						
Remote Sense	-	Up to 0.5V compensation per output cable						
Communication Interface	-	RS232 & RS485 standard, IEEE488 optional						
Series & Parallel Operation	-	Series: Up to two units; Parallel: Up to five units in master-slave configuration						
AC Input Voltage range	-	85-265VAC (47-63Hz)						
Inrush Current (100/200VAC) (3)	-	15/30A, 200W models, 15A, 400W models, 30A, 800W models						
Hold Up Time (Typ) at 100VAC	ms	20						
Power Factor Correction	-	Complies with EN61000-3 Class A (0.99 typ)						
Temperature Range	-	Operating: 0°C - 50°C; Storage: -20°C to +70°C						
Humidity (non condensing)	-	Operating: 30°C - 90% RH, Storage 10°C - 95%RH						
Cooling	-	Internal fan						
Withstand Voltage	-	Input to Ground 2kVAC, Input to Output 3kVAC, Output to Ground 500VAC for 1 min.						
Isolation Resistance	Ω	>100MΩ at 25°C & 70%RH						
Vibration & Shock (non-op.)	-	Vibration:10-55Hz(1 min.) 2G constant X, Y, Z, when correctly mounted; Shock: <20G						
Safety Agency Approvals	-	UL3111-1, EN61010-1, CE Mark						
Conducted & Radiated EMI	-	EN55022-B conducted, A radiated, FCC Class B conducted, A radiated, VCCI-B conducted, -A radiated						
Warranty	yrs	3						

(1) Recovery to within +/-50mV after load change of 50-100% (2) Over 8 hour period following 30 minute warm up time (3) 25°C ambient (cold start)



Model Selector

Model	Voltage Adjust Range	Current Adjust Range	Max Power	Ripple 5Hz-1MHz mV	Noise 20MHz BW mV	Ripple 5Hz-1MHz mA	Efficiency % (100/200VAC)	Weight kg
ZUP6-33	0-6V	0-33	198	5	50	50	69 / 72	2.9
ZUP6-66	0-6V	0-66	396	5	50	100	74 / 77	3.2
ZUP6-132	0-6V	0-132	792	8	100	200	74 / 77	5.8
ZUP10-20	0-10	0-20	200	5	50	25	73 / 77	2.9
ZUP10-40	0-10	0-40	400	5	50	50	79 / 82	3.2
ZUP10-80	0-10	0-80	800	8	90	100	77 / 81	5.8
ZUP20-10	0-20	0-10	200	5	50	15	74 / 78	2.9
ZUP20-20	0-20	0-20	400	5	50	30	79 / 83	3.2
ZUP20-40	0-20	0-40	800	5	80	60	79 / 82	5.8
ZUP36-6	0-36	0-6	216	5	50	7.5	76 / 80	2.9
ZUP36-12	0-36	0-12	432	5	50	15	80 / 84	3.2
ZUP36-24	0-36	0-24	864	5	70	30	80 / 84	5.8
ZUP60-3.5	0-60	0-3.5	210	5	50	5	75 / 79	2.9
ZUP60-7	0-60	0-7	420	5	50	10	80 / 84	3.2
ZUP60-14	0-60	0-14	840	5	60	20	80 / 84	5.8
ZUP80-2.5	0-80	0-2.5	200	20	70	5	78 / 82	2.9
ZUP80-5	0-80	0-5	400	20	70	10	83 / 87	3.2
ZUP120-1.8	0-120	0-1.8	216	20	80	5	78 / 82	2.9
ZUP120-3.6	0-120	0-3.6	432	20	80	10	82 / 86	3.2

Options and Accessories

Option	Model Suffix	Part Number
Front panel terminals (20A max) ⁵	/L ⁴	ZUP200/400/L ⁴
Front panel terminals (20A max) ⁶	/L ⁴	ZUP800/L ⁴
IEC320 cable Europe plug	/E	ZUP/E
Serial link cable RJ-45	/W	ZUP/W
GPIO Controller		GP485A
Dual Unit Assembly		NL200*
(accepts 200W or 400W models)		
19" 3U rack (accepts up to 6 200/400W models)	NL100*	
Blanking panels for NL100 (19 in. rack)	NL101*	
RS232 Communications Cable DB-9F	ZUP/NC401	
RS232 Communications Cable DB-25F	ZUP/NC403	
RS485 Communications Cable DB-9F	ZUP/NC402	
RS485 Communications Cable DB-25F	ZUP/NC404	
User Manual		NL102
* (See website for more details)		
⁴ Not available with ZUP80 or ZUP120 models.		
⁵ 200W and 400W models		
⁶ 800W models		



Outline Drawing 200/400W

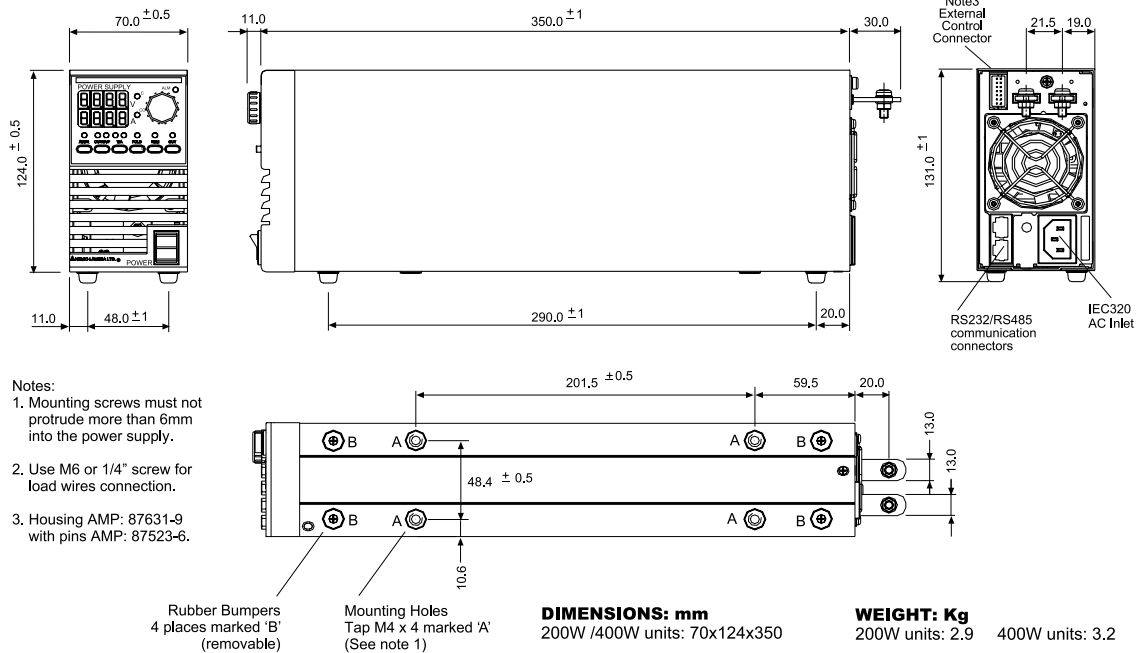

Outline Drawing 800W

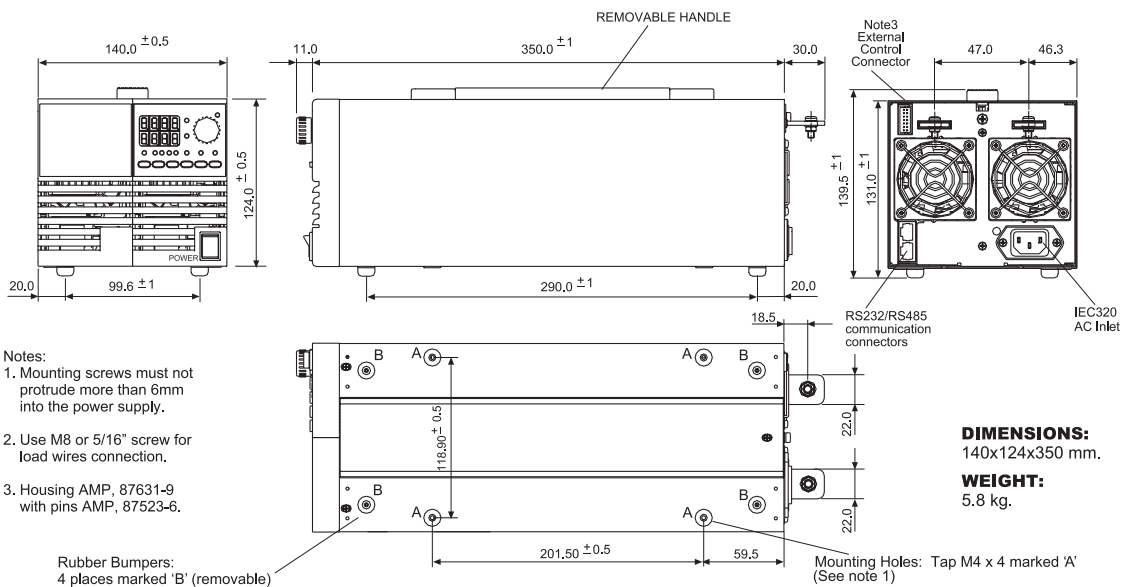



AC-DC and DC-DC Power Modules (Bricks)

A comprehensive range of standard dc-dc “bricks” and baseplate conduction cooled ac-dc modules for integration into equipment with minimal external components.

DC inputs include 24V and 48V, nominal 110V (60 to 160V range) for rail applications (CN-A series) and nominal 280V (200 to 400V) high voltage models.

		<i>Page No.</i>
	PFE Series 300- 1008W Single Output AC-DC	176
	PF Series 756 - 1512W Single Output AC-DC	179
	iSA Series 36 - 82W Single Output DC-DC	182
	iEA Series 66 - 78W Single Output DC-DC	184
	iQE Series 96 - 204W Single Output DC-DC	186
	iQG Series 300W Single Output DC-DC	188
	iQL Series 150 - 300 Single Output DC-DC	190
	CN-A Series 30-200W Single Output DC-DC	192
	iHG Series 50 - 300W Single Output DC-DC	195
	PAH Series 29 - 451W Single Output DC-DC	197
	PAH300/450 Series 300 & 450W Single Output DC-DC	200
	PAF500F & PAF600F Series 500 & 600W Single Output DC-DC	203
	PAF450F/600F 280 Series 450 & 600W Single Output DC-DC	206
	PAF700F Series 700W Single Output DC-DC	209
	PH-S Series 50 - 600W Single Output DC-DC	212
	PH-F Series 50 - 300W Single Output DC-DC	214



- Low profile, small size
- 100°C baseplate temperature
- High power density
- High Efficiency
- Suitable for conduction cooling

PFE300 - 1000 Series

300 to 1008W
AC-DC Power Module

Key Market Segments & Applications

- Bulk DC Power for DC-DC Converters & POL Converters
- Custom Fanless Power Supplies
- LED Signs
- Traffic Signalling
- Toll Equipment

PFE300 - 1000 Features and Benefits

Features

- Low profile
- High Efficiency
- Power Factor Corrected (PFC)
- Operation up to 100°C baseplate

Benefits

- Assists system integration
- Easier to cool
- Supports Global Use
- Operates in harsh environments

Specifications

ITEMS	MODEL	PFE300S PFE500S	PFE700S	PFE500F	PFE1000F
AC Input	VAC	85 to 265VAC, 47-63Hz (Reduced PFC above 63Hz)			
Input Current (100 / 220VAC)	A	4.0 / 2.0	8.8 / 4.4	6.8 / 3.4	13.6 / 6.6
Model dependant		6.2 / 3.2			
Inrush Current (100/200VAC) (1)	A	20 / 40 peak			
Power Factor		0.95 minimum			
Output Voltage Setpoint Accuracy	-	±2%	±1V	±2%	±2%
Ripple and Noise (1)	-	1%	4V	1%	1%
Over Current Protection	%	105 - 140% (Automatic Recovery)			
Over Voltage Protection	-	125 - 145%	60 - 69.6V	125 - 145%	125 - 145%
Series Operation	-	Yes			
Parallel Operation	-	No	Yes (Droop mode)	Yes (Single wire)	Yes (Single wire)
Power On Signal (ENA)	-	Open collector (10mA sink current). Low (on) when output is present			
Auxilliary Supply	-	None	None	10 - 14V, 20mA	10 - 14V, 20mA
Remote On/Off (Opto isolated)	-	None	None	High = On	High = On
Overtemperature Protection		Yes			
Operating Baseplate Temp.	°C	-40°C to +100°C (2)			
Storage Temperature	°C	-40°C to +100°C			
Humidity (non condensing)		Operating: 20 - 95%RH, Non Operating: 10 - 95%RH			
Cooling		Conduction			
Withstand Voltage (1 min) (4)		Input to Output 3kVAC, Input to Baseplate 2.5kVAC, Output to Baseplate 1.5kVDC for S models, 500VDC for F models			
Isolation Resistance	Ω	Output to baseplate: 100MΩ Ohm at 500VDC, 25°C ambient, 70%RH			
Vibration (non operating)		10-55Hz (1 min sweep), constant amplitude 0.825mm (max 49m/s ²), X, Y, Z 1 hour each			
Shock		196.1m/s ²			
Safety Certifications		UL60950-1, CSA60950-1 (cUL), EN60950-1, CE mark (LVD)			
Weight	g	250	250	300	500
Size (WxHxL)	mm	61 x 12.7 x 116.8mm		70 x 12.7 x 122mm	100 x 13.4 x 160mm
	in	2.4 x 0.5 x 4.6"		2.76 x 0.5 x 4.8"	3.94 x 0.53 x 6.3"
Warranty	yrs	2			

Notes: (Consult Installation Manual for detailed specifications, test methods and application notes)

1) External components are required, Consult application notes.

2) PFE500-12, PFE500F-12: -40°C to 85°C. See instruction manuals for derating curves. PFE1000F28 & PFE1000F48: -40°C to 85°C below 170VAC input voltage. See instruction manuals for derating curves.

3) PFE500F, PFE1000F: 500VDC Output to baseplate



Model Selector

Model	Output Voltage (V)	Adjust. Range (V)	Maximum Current (A)	Maximum Wattage (W)	Load Reg. (mV)	Line Reg. (mV)	Efficiency typ (5)
PFE300S-12	12	9.6 - 14.4	25	300	48	48	81 / 83
PFE500S-12	12	9.6 - 14.4	33	396	48	48	82 / 83
PFE500F-12	12	9.6 - 14.4	42	504	48	48	81 / 83
PFE1000F-12	12	9.6 - 14.4	60	720	48	48	80 / 82
PFE300S-28	28	22.4 - 33.6	10.8	302	56	56	83 / 85
PFE500S-28	28	22.4 - 33.6	18	504	56	56	84 / 86
PFE500F-28	28	22.4 - 33.6	18	504	56	56	84 / 86
PFE1000F-28	28	22.4 - 33.6	36	1008	56	56	84 / 86
PFE300S-48	48	38.4 - 57.6	6.3	302	96	96	84 / 86
PFE500S-48	48	38.4 - 57.6	10.5	504	96	96	84 / 86
PFE500F-48	48	38.4 - 57.6	10.5	504	96	96	84 / 86
PFE1000F-48	48	38.4 - 57.6	21	1008	96	96	84 / 86
PFE700S-48	51	None	14	714	50 - 57V (6)		86 / 89

(5) 100 / 200VAC

(6) Total regulation range

PFE500S Basic connection

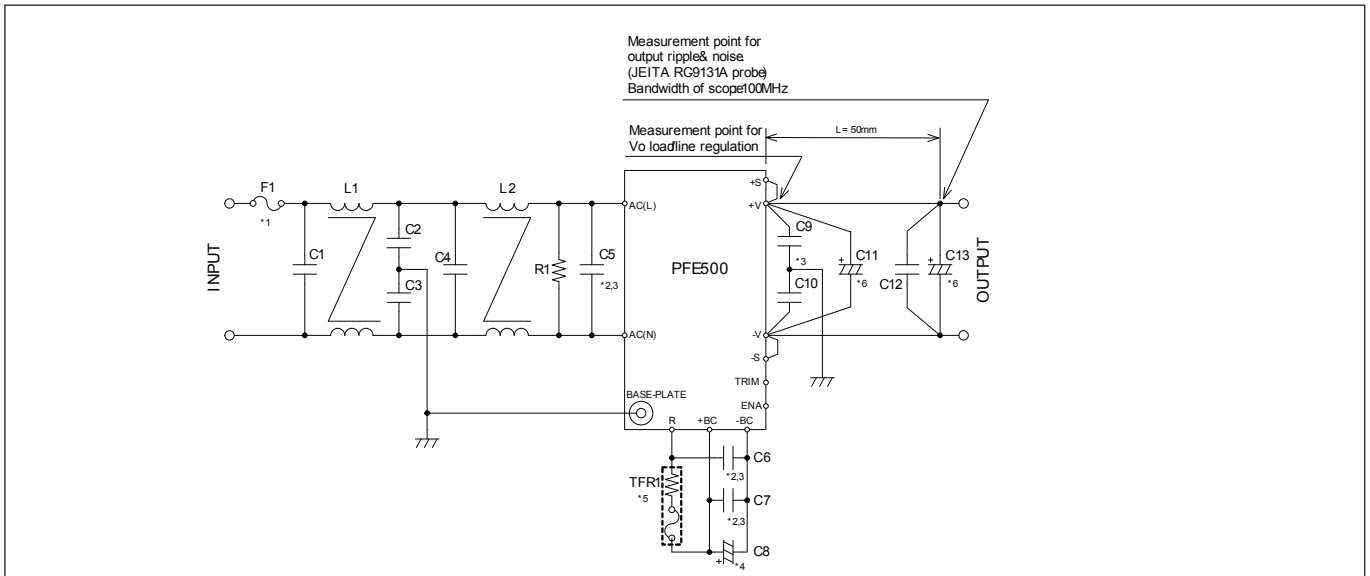

Heatsink Table (PFE-S Models only)

Heatsink	Size (mm)	Thermal Resistance
HAF-10L	116.8 x 25.4 x 61	2.2°C/W
HAF-15L	116.8 x 38.1 x 61	1.9°C/W
HAF-15T	116.8 x 38.1 x 61	1.5°C/W

Heatsink Table (PFE-F Models only)

PFE500-F		
HAL-F12T	122 x 35 x 69.9	0.97°C/W
PFE1000-F		
HAM-F10T	160 x 33.4 x 100	0.78°C/W

Options

Suffix	Description
Blank	M3 tapped mounting inserts (4)
/T	3.3mm non-threaded inserts (4)



Outline Drawing PFE500S & PFE700S

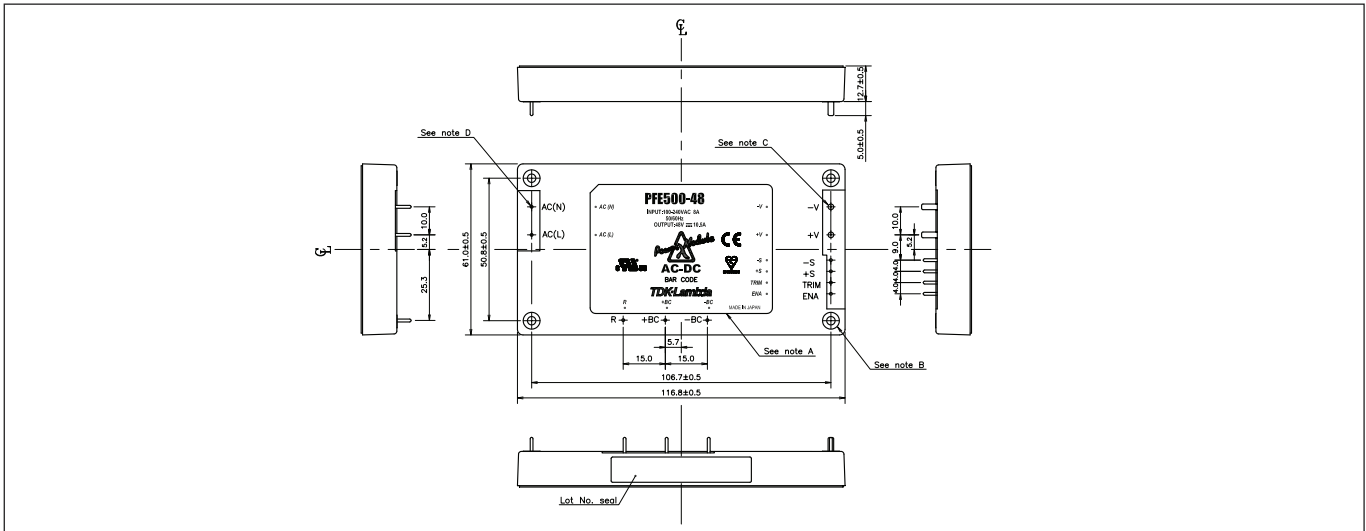

Outline Drawing PFE500F

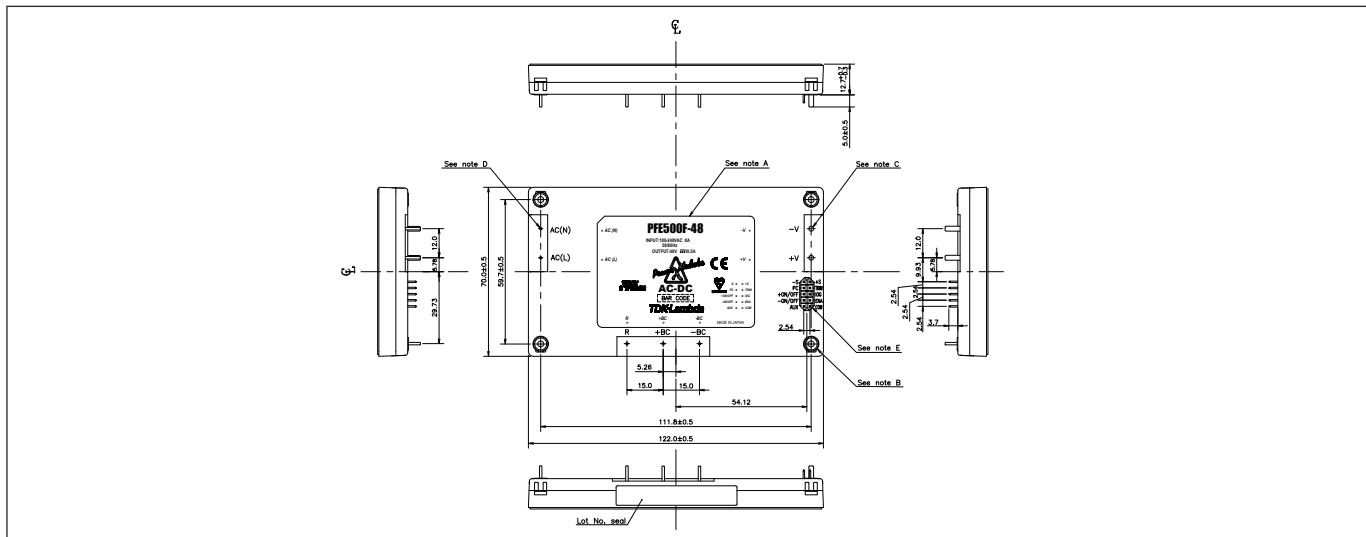

Outline Drawing PFE1000F

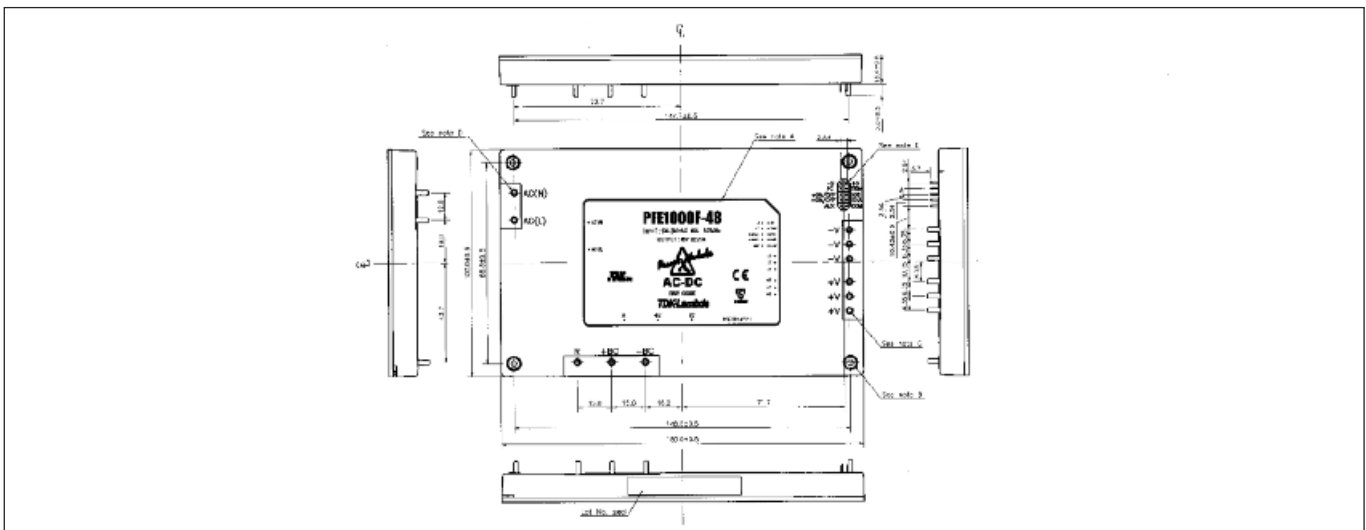



- Suitable for use in Custom Power Supplies
- Provides high voltage DC to TDK-Lambda's PH & PAF Power Modules
- Parallel operation on PF Series
- 12.7mm profile

PF Series

Rectifier & Power Factor Correction Modules

PF Features and Benefits

Features

- Low profile
- Parallel
- Power Factor corrected (PF)
- Operation up to 85°C

Benefits

- Assist system integration
- For higher power or N+1 operation
- Supports Global Use
- Operates in harsh environments

Specifications

Items		PF500A-360	PF1000A-360
AC Input Voltage range & Frequency	VAC	85-265 wide range	
Input Frequency	-	47 - 63Hz	
Output Voltage	VDC	360	
Output Power at 100/200VAC	W	504/756W	1008/1512W
Load Regulation	-	10V	
Line Regulation	-	5V typical	
Inrush Current	A	External pins provided connection for in rush resistor	
Efficiency (typ) at full load	%	90% (100VAC), 95% (200VAC)	
Power Factor	-	Meets EN61000-3-2 (0.95 typical)	
Overcurrent Protection	-	Converter shutdown	
Overvoltage Protection	V	390 - 400VDC, manual reset	
Thermal Shutdown	-	Shuts down Inverter, manual reset	
Inverter Good Signal	-	Yes, when inverter is operating correctly	
Enable Signal	-	Signal provided to enable "PH" DC-DC converters	
Parallel Connection	-	Single wire current share	
Auxiliary Output Voltage	-	Yes - see installation manual	
Operating Baseplate Temperature	°C	-20°C to +85°C (no derating)	
Storage Temperature	°C	-40°C to +85°C	
Cooling	-	Conduction (see installation manuals for heatsinks)	
Withstand Voltage	-	Input - Ground 3kVAC for 1 min	
Safety Agency Approvals	-	UL60950-1, CSA22.2 No.60950-1, EN60950-1, & CE Mark	
Weight	g	130	200
Size (WxHxD)	mm	See outline line drawings	
Warranty	yrs	2	

Notes: (Consult Installation Manual for detailed specifications, test methods and application notes)



Outline Drawing PF500A

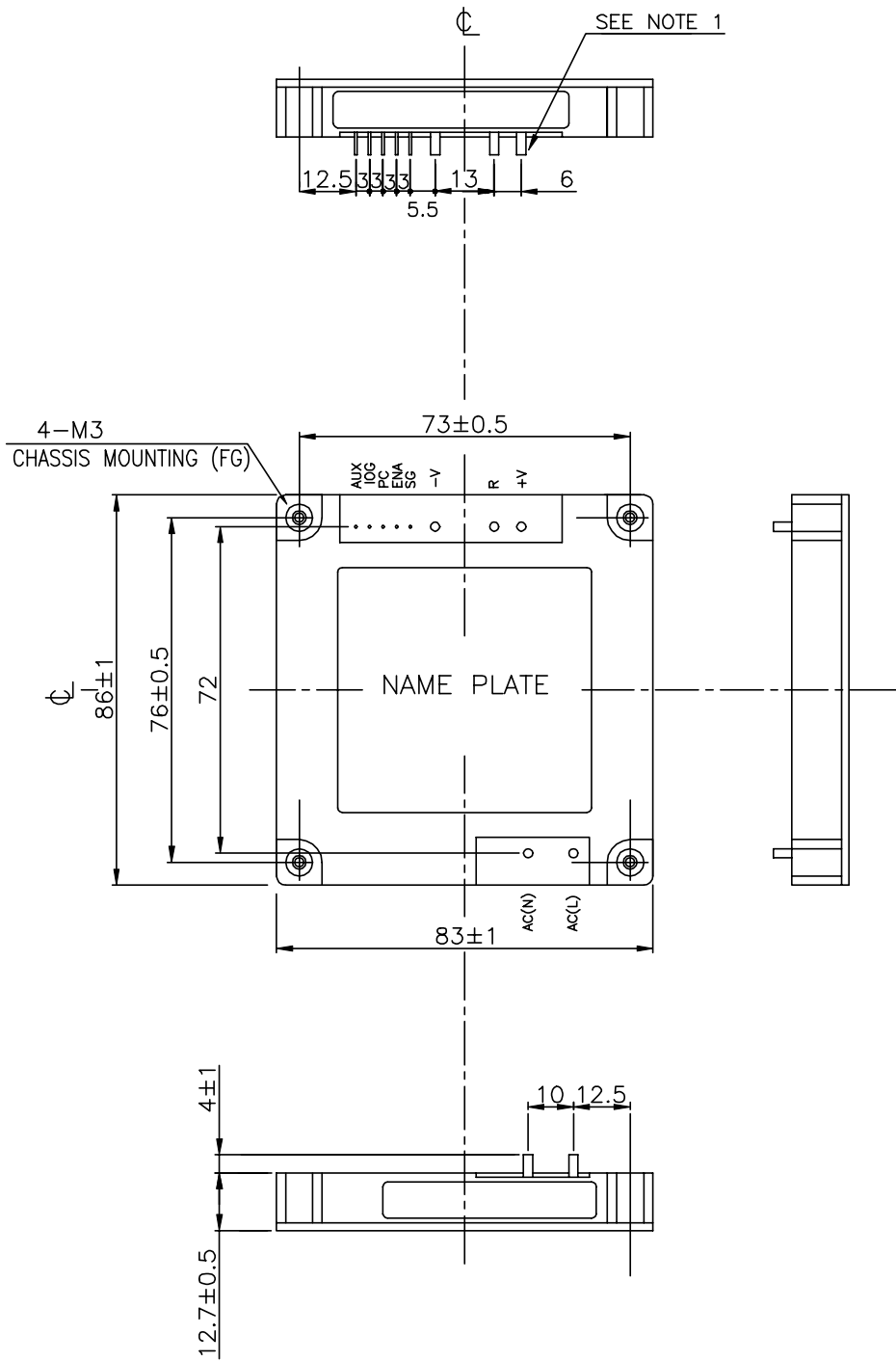



Outline Drawing PF1000A

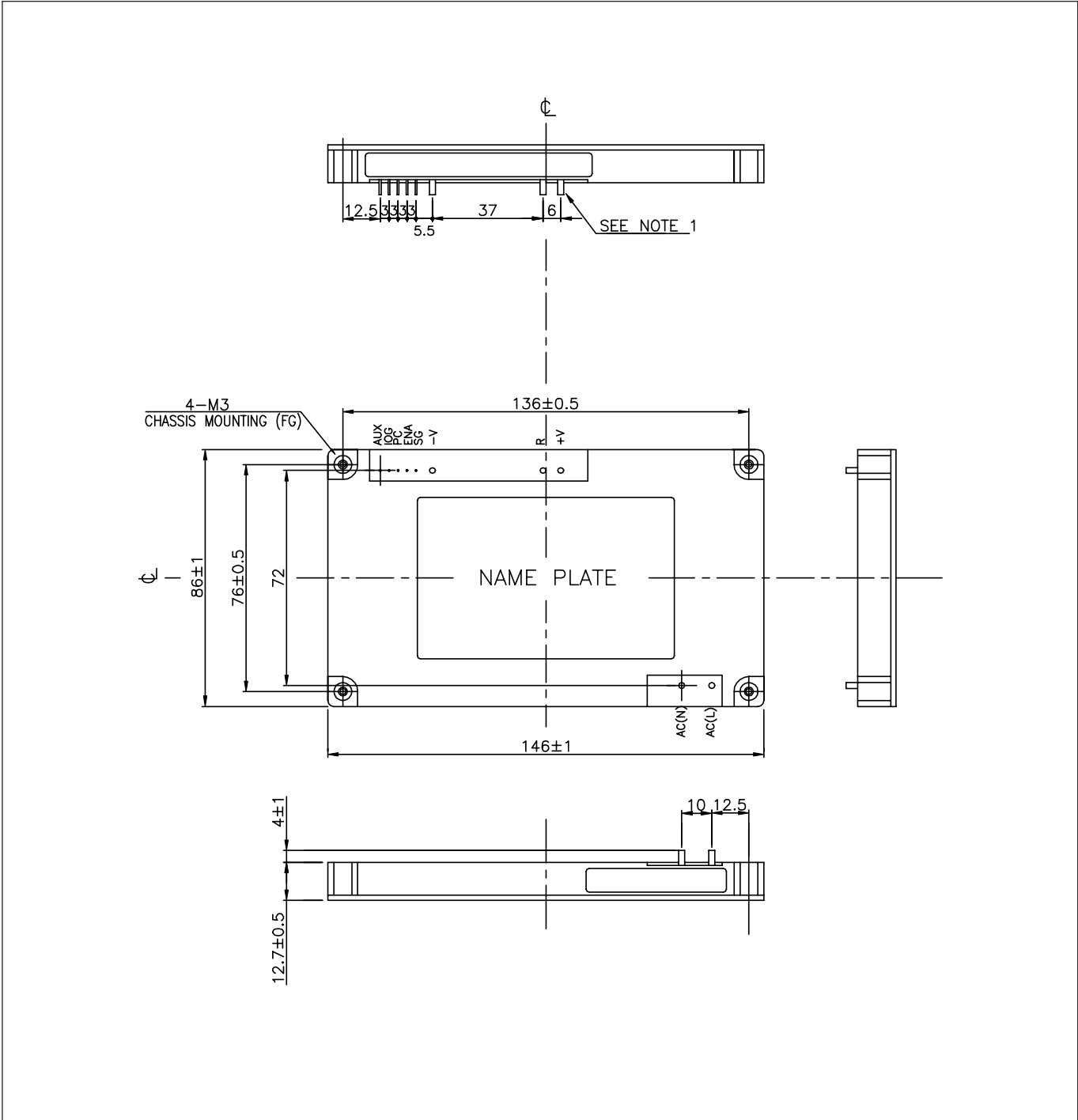

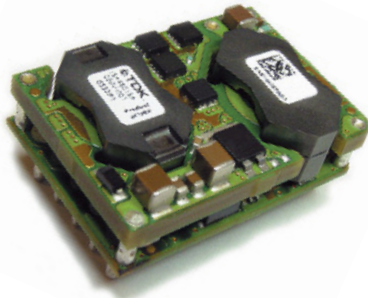

- Standard Sixteenth Brick Footprint (DOSA)
- 36-75VDC Input
- 1.2V 30A - 12V 6.5A Nominal Outputs
- Through Hole Mounting
- Low 12.7mm Profile
- 1500VDC Basic Isolation

iSA Series

36 - 82.5W

Sixteenth Brick Converter

iSA Features and Benefits

Features

- High operating efficiency (up to 90%)
- Constant switching frequency
- 44% smaller than eighth brick

Benefits

- Reduced system heating
- Easier system filtering
- Optimization of board space

Specifications

ITEMS		MODEL	iSA480						
			1.2	1.5	1.8	2.5	3.3	5	12
Nominal Output Voltage	VDC								
Input Voltage Range	VDC		36 to 75						
Input Current (max)	A		4						
Output Voltage Tolerance	VDC	1.164-1.236	1.45-1.55	1.74-1.86	2.42-2.58	3.20-3.40	4.85-5.15	11.58-12.42	
Ripple & Noise (max) (pk to pk)	mV		75		100			200	
Line Regulation (max)	mV		7				10	24	
Load Regulation (max)	mV		8				10	24	
Overload Protection	%		Inception- 130-147% of rated output; Short circuit auto recovery						
Overvoltage Protection	VDC	1.5-2.0	1.7-2.3	2.1-2.6	2.7-3.5	3.75-4.65	5.7-6.7	13.6-15.7	
Remote Sense	-		Yes						
Remote On / Off	-		Positive and Negative Logic available, see Feature Set						
Temperature (operating)	°C		-40°C to +125°C						
Temperature (storage)	°C		-55°C to +125°C						
Humidity (operating)	-		20 - 95% RH Non condensing						
Humidity (storage)	-		10 - 95% RH Non condensing						
Cooling	-		Convection or forced air						
I/O Isolation Voltage	VDC		1500						
Vibration (non operating)	-		5 to 50Hz @ 0.5g (4.9m/s ²), and 50 to 500Hz @ 1.5g (14.7m/s ²) per Bellcore TR-EOP-000063-5.4.4						
Shock	-		196.1m/s ²						
Safety Agency Approvals	-		UL60950 (US and Canada), VDE0805 (IEC60950), CB scheme (IEC60950), CE Mark (LVD)						
Weight (max)	g		30.4						
Size	mm		33 x 22.9 x 12.7						
Warranty	yrs		3						



Model Selector

Model	Voltage (V)	Adjust Range (V)	Max. Curr. (A)	Max. Output Power (W)	Efficiency at Full Load (%)
iSA48007A120V-001-R	12	10.8 - 13.2	6.5	78	90
iSA48007A120V-007-R	12	10.8 - 13.2	6.5	78	90
iSA48015A050V-001-R	5	4.5 - 5.5	15	75	90
iSA48025A025V-001-R	2.5	2.25 - 2.75	25	62.5	85
iSA48025A033V-000-R	3.3	2.97 - 3.63	25	82.5	88
iSA48025A033V-001-R	3.3	2.97 - 3.63	25	82.5	88
ISA48030A012V-000-R	1.2	1.08 - 1.32	30	36	75
ISA48030A012V-001-R	1.2	1.08 - 1.32	30	36	75
ISA48030A015V-001-R	1.5	1.35 - 1.65	30	45	79
ISA48030A018V-001-R	1.8	1.62 - 1.98	30	54	82

NB other configurations on request

Recommended Hole Pattern

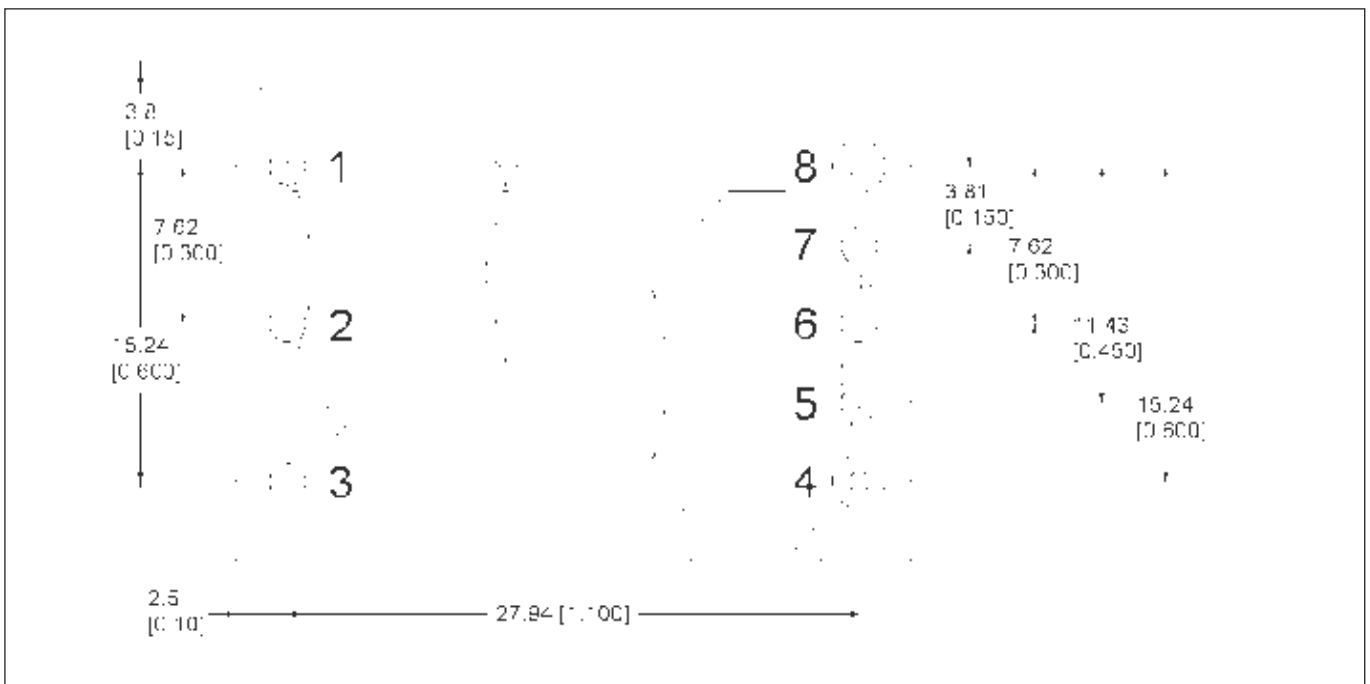

Feature Set

Feature Set	Positive Logic On / Off	Negative Logic On / Off	0.110" Pin Len.	0.180" Pin Len.	0.145" Pin Len.	Latching OVP
00	X				X	
01		X			X	
02	X		X			
03		X	X			
06	X			X		
07		X		X		
11		X			X	X
17		X		X		X

PIN Assignments

Pin	Function
1	Vin (+)
2	On / Off
3	Vin (-)
4	Vout (-)
5	Sense (-)
6	Trim
7	Sense (+)
8	Vout (+)

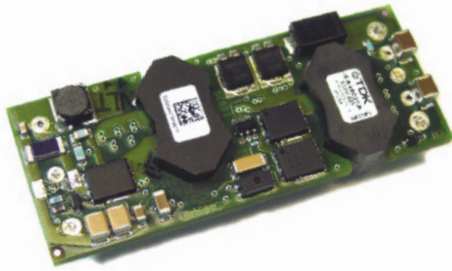

- Standard Eighth Brick Footprint
- 36-75VDC Input
- 3.3V 20A - 28V 2.67A Nominal Output
- Through Hole Mounting
- Low 8.8mm Profile
- 1500VDC Basic Isolation

iEA Series

66 -78W

Eighth Brick DC-DC Converters

iEA Features and Benefits

Features

- High operating efficiency (up to 91%)
- Constant switching frequency
- Open frame design

Benefits

- Reduced system heating
- Easier system filtering
- Better thermal performance

Specifications		iEA Series						
ITEMS	MODEL	3.3	5	12	15	18	28	
Nominal Output Voltage	VDC	3.3	5	12	15	18	28	
Input Voltage Range	VDC	36 - 75						
Input Current (max)	A	4.5						
Output Voltage Tolerance	VDC	3.20 - 3.40	4.85 - 5.15	11.58 - 12.42	14.47 - 15.52	17.28 - 18.72	26.88 - 29.12	
Ripple & Noise (max) (pk-pk) (1)	mV	100	125	200	150	200	250	
Line Regulation (max)	mV	7	10	24	35	45	70	
Load Regulation (max)	mV	8	10	24	35	45	70	
Overload Protection (typ)	A	29	20	8.5	6	4.4	4	
Overvoltage Protection	VDC	3.75 - 4.4	5.7 - 6.7	13.6 - 15.7	16.8 - 22.0	20.0 - 26.0	32.0 - 38.0	
Remote Sense	-	Yes						
Remote On / Off	-	Positive or Negative Logic, see Model Selector						
Temperature (operating)	°C	-40°C to +125°C						
Temperature (storage)	°C	-55°C to +125°C						
Humidity (operating)	-	20 - 95% RH Non condensing						
Humidity (storage)	-	10 - 95% RH Non condensing						
Cooling	-	Convection or forced air						
Isolation Voltage	VDC	1500						
Vibration (non operating)	-	5~50Hz@0.5g (4.9m/s ²), & 50~500Hz@1.5g (14.7m/s ²) per Bellcore TR-EOP-000063-5.4.4						
Shock	-	196.1m/s ²						
Safety Agency Approvals	-	UL60950 (US and Canada), VDE0805 (IEC60950), CB scheme (IEC60950), CE Mark (LVD)						
Weight (max)	g	30.4						
Size	mm	58.4 x 22.9 x 8.8						
Warranty	yrs	3						

Notes: (1) Measured across one 0.1µF ceramic capacitor and one 10µF tantalum ceramic capacitor; BW = 20MHz



Model Selector

Model	Voltage Output (V)	Voltage Adjust (V)	Output Curr. (A)	Max. Output Power (W)	Efficiency at Full Load (%)	Pos. Logic On/Off	Neg. Logic On/Off
iEA48020A033V-000-R	3.3	2.97 - 3.63	20	66	90	X	
iEA48020A033V-001-R	3.3	2.97 - 3.63	20	66	90		X
iEA48015A050V-000-R	5	4.5 - 5.5	15	75	90	X	
iEA48015A050V-001-R	5	4.5 - 5.5	15	75	90		X
iEA48007A120V-000-R	12	10.8 - 13.2	7	78	91	X	
iEA48007A120V-001-R	12	10.8 - 13.2	7	78	91		X
iEA48005A150V-001-R	15	13.5 - 16.5	4.5	67.5	90		X
iEA48004A180V-001-R	18	16.2 - 19.8	3.75	67.5	90.5		X
iEA48003A280V-001-R	28	19.6 - 30.8	2.67	75	90		X

Recommended Footprint (Top view)

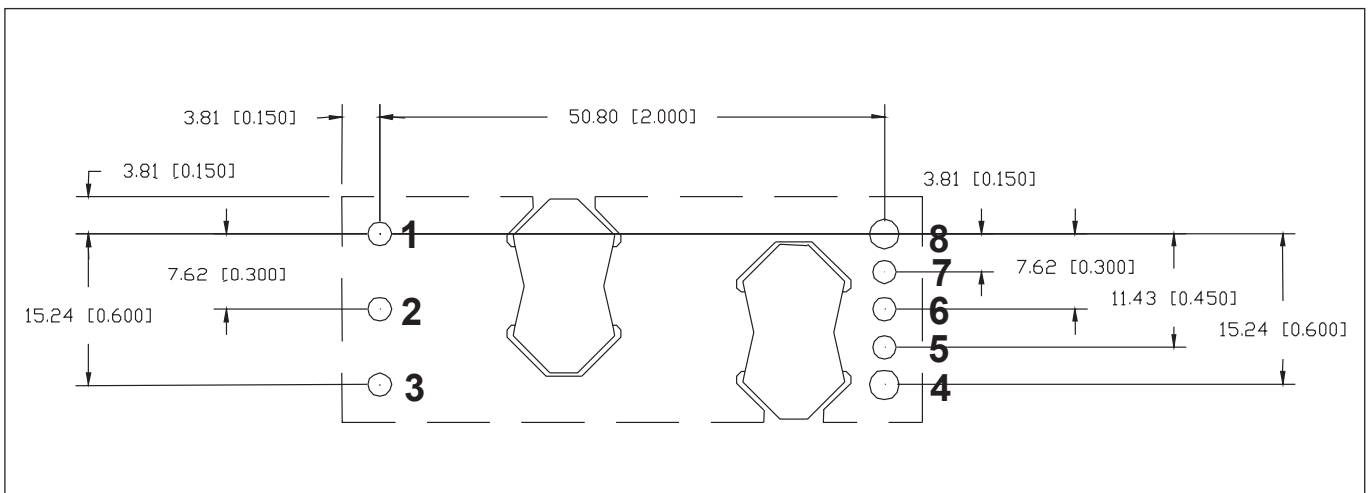

Pinout

Pin#	Function
1	Vin (+)
2	On / Off
3	Vin (-)
4	Vout (-)
5	Sense (-)
6	Trim
7	Sense (+)
8	Vout (+)

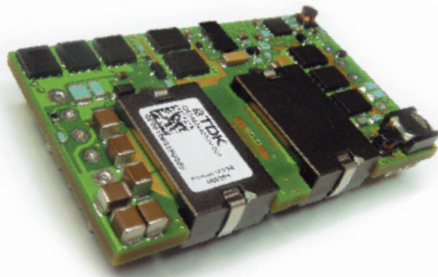

- Standard Quarter Brick Footprint
- 18-36VDC, 36-75VDC & Wide Range 18-60V Inputs
- 3.3V 40A - 15V 10A Nominal Outputs
- Through Hole Mounting
- Low 10.41mm Profile
- 1500VDC Basic Isolation

iQE Series

96 - 204W

Quarter Brick Converter

iQE Features and Benefits

Features

- High operating efficiency (>90%)
- Constant switching frequency
- Low component count

Benefits

- Reduced system heating
- Easier system filtering
- Higher reliability

Specifications		iQE Series				
ITEMS	MODEL	3.3	5	8	12	15
Nominal Output Voltage	VDC	3.3	5	8	12	15
Input Voltage Range	VDC	See model Selector				
Input Current (max)	A	10				
Output Voltage Tolerance	VDC	3.2 - 3.4	4.85 - 5.15	7.76 - 8.24	11.58 - 12.42	14.48 - 15.52
Ripple & Noise (max) (pk to pk) (1)	mV	150	150	150	150	150
Line Regulation (max)	mV	10	15	25	30	30
Load Regulation (max)	mV	10	30	25	30	30
Overload Protection (typ)	%	Inception - 133-158% of rated output; Short circuit - auto recovery				
Overvoltage Protection	VDC	3.8 - 4.6	5.7 - 6.7	8.9 - 11	13.6 - 16.5	16.7 - 21
Remote Sense	-	Yes				
Remote On / Off	-	Positive or Negative Logic available, see Model Selector				
Temperature (operating)	°C	-40°C to +125°C				
Temperature (storage)	°C	-55°C to +125°C				
Humidity (operating)	-	20 - 95% RH Non condensing				
Humidity (storage)	-	10 - 95% RH Non condensing				
Cooling	-	Convection or forced air				
Isolation Voltage	VDC	1500				
Vibration (non operating)	-	5 to 50Hz @ 0.5g (4.9m/s ²), and 50 to 500Hz @ 1.5g (14.7m/s ²) per Bellcore TR-EOP-000063-5.4.4				
Shock	-	196.1m/s ²				
Safety Agency Approvals	-	UL60950 (US and Canada), VDE0805 (IEC60950), CB scheme (IEC60950)				
Weight (max)	g	50				
Size	mm	57.9 x 36.8 x 10.41				
Warranty	yrs	3				

Notes: (1) Measured across one 22µF and one 0.1µF ceramic capacitor; BW = 20MHz



Model Selector

Model	Input Voltage (V)	Output Voltage (V)	Adjust Range (V)	Max. Current (A)	Max. Output Power (W)	Efficiency
IQE24007A150V-001-R	18-36	15	13.5-16.5	7	105	90
IQE24007A150V-007-R	18-36	15	13.5-16.5	7	105	90
IQE24009A120V-001-R	18-36	12	10.8-13.2	9	108	88
IQE24009A120V-007-R	18-36	12	10.8-13.2	9	108	88
IQE24012A080V-001-R	18-36	8	7.2-8.8	12	96	92
IQE24012A080V-007-R	18-36	8	7.2-8.8	12	96	92
IQE24024A050V-001-R	18-36	5	4.5-5.5	24	120	90
IQE24024A050V-007-R	18-36	5	4.5-5.5	24	120	90
IQE24030A033V-001-R	18-36	3.3	2.97-3.63	30	99	90
IQE24030A033V-007-R	18-36	3.3	2.97-3.63	30	99	90
IQE48010A150V-001-R	36-75	15	13.5-16.5	10	150	91
IQE48010A150V-007-R	36-75	15	13.5-16.5	10	150	91
IQE48014A080V-001-R	36-75	8	7.2-8.8	14	112	92
IQE48017A120V-000-R	36-75	12	10.8-13.2	17	204	93
IQE48017A120V-001-R	36-75	12	10.8-13.2	17	204	93
IQE48017A120V-007-R	36-75	12	10.8-13.2	17	204	93
IQE48030A050V-000-R	36-75	5	4.5-5.5	30	150	91
IQE48030A050V-001-R	36-75	5	4.5-5.5	30	150	91
IQE48040A033V-000-R	36-75	3.3	2.97-3.63	40	132	89.5
IQE48040A033V-001-R	36-75	3.3	2.97-3.63	40	132	89.5
IQE48040A033V-007-R	36-75	3.3	2.97-3.63	40	132	89.5
IQE4W011A120V-001-R*	18-60	12	10.8-13.2	11	132	90

NB: other configurations on request * New Wide Range Model - Contact Sales for more information

Feature Set

Feature Set	Positive Logic On / Off	Negative Logic On / Off	0.110" Pin Len.	0.180" Pin Len.	0.145" Pin Len.
00	X				X
01		X			X
02	X		X		
03		X	X		
06	X			X	
07*		X		X	

* Preferred feature set
Model Number Example: iQE24030A033V-007-R

PIN Out

PIN	Function
1	Vin (+)
2	On / Off
3	Vin (-)
4	Vout (-)
5	Sense (-)
6	Trim
7	Sense (+)
8	Vout (+)

Recommended Hole Pattern (Top View)

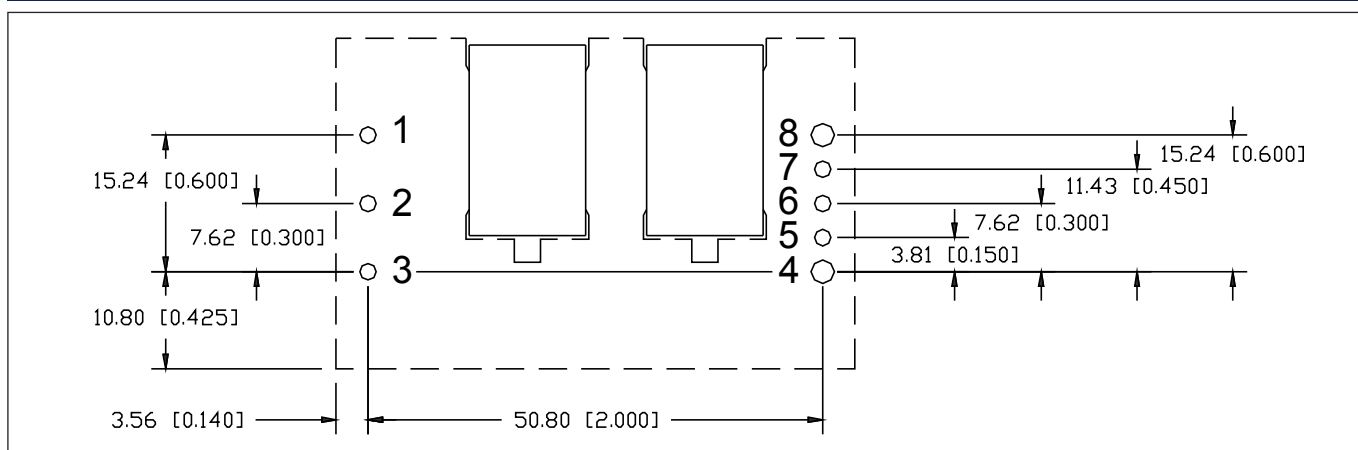

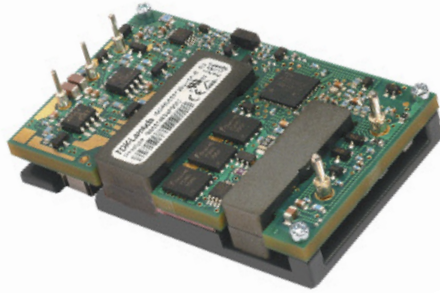

- Standard Quarter Brick Footprint
- 36-75VDC Input
- 12V 25A Output
- Through Hole Mounting
- Low 12.7mm Profile (13.21mm with baseplate)
- 1500VDC Basic Isolation

iQG Series

300W Quarter Brick converters

iQG Features and Benefits

Features

- High operating efficiency (up to 95%)
- Reduced system heating
- Constant 115kHz switching frequency
- Supports complex digital systems

Benefits

- Starts with pre-biased output
- Baseplate cooled
- Easier system filtering
- Allows for conduction cooling

Specifications

MODEL		iQG
ITEMS		
Nominal Output Voltage	VDC	12V
Input Voltage Range	VDC	36 - 75VDC
Input Current (max)	A	9A
Efficiency	%	67% loading: 95%, 100% loading: 94% - 48V Input
Output Voltage Tolerance	VDC	11.1 - 12.1V
Ripple & Noise (max) (pk - pk)	mV	70mV
Line Regulation (max)	mV	100mV
Load Regulation (typical)	mV	50mV (10 - 100% load)
Overload Protection	A	Inception- 30A; Short circuit - auto recovery
Overvoltage Protection	VDC	13.7 - 15.6V (Latching)
Remote Sense	-	None
Remote On / Off	-	Negative Logic standard. Positive logic available, contact factory
Temperature (operating)	°C	-40°C to +125°C (See detailed datasheet for derating)
Temperature (storage)	°C	-55°C to -125°C
Humidity (operating)	%RH	20 - 95% RH Non condensing
Humidity (storage)	%RH	10 - 95% RH Non condensing
Cooling	-	Conduction, convection or forced air (See detailed datasheet for derating)
Isolation Voltage	VDC	1500VDC Input to Output, Input to Baseplate
Vibration (non operating)	-	5 to 50Hz@0.5g (4.9m/s ²), and 50 to 500Hz@1.5g (14.7m/s ²) per Bellcore TR-EOP-000063-5.4.4
Shock	-	196.1m/s ²
Safety Agency Certifications	-	UL60950-1 (US and Canada), VDE0805 (IEC60950-1), CB scheme (IEC60950-1)
Weight (max)	g	55g open frame, 70g with baseplate
Size (LxWxH)	mm	58.91 x 36.83 x 13.21 (Baseplate version)
Warranty	yrs	3



Model Selector

Model	Input Voltage (V)	Output Voltage (V)	Max. Curr. (A)	Max. Output Power (W)	On/Off Polarity	Pin Length	Base Plate
iQG48025A120V-101-R	36 - 75	12	25	300	Neg	0.145"	Yes
iQG48025A120V-109-R	36 - 75	12	25	300	Neg	0.180"	Yes

Pinout

PIN	Function	PIN	Function
1	Vin (+)	5	None
2	On / Off	6	None
3	Vin (-)	7	None
4	Vout (-)	8	Vout (+)

Recommended Footprint iQG Series (Top view)

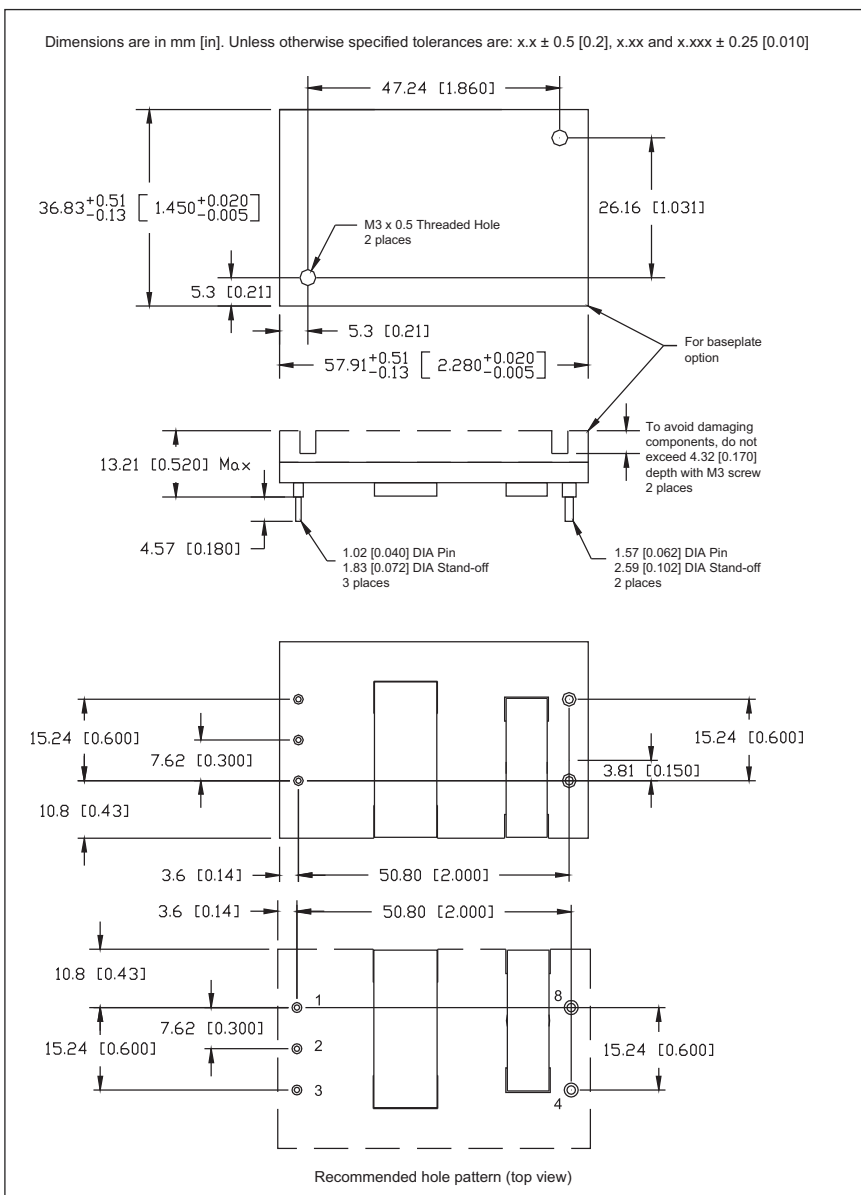



- Standard Quarter Brick Footprint
- 18-36 & 36-75VDC Inputs
- From 2.5V 60A up to 12V 25A Nominal Outputs
- Through Hole Mounting
- 1500VDC Basic Isolation
- Baseplate cooling

iQL Series

72-308W

Quarter Brick Converter

iQL Features and Benefits

Features

- High operating efficiency (up to 93.5%)
- Constant switching frequency
- Baseplate

Benefits

- Reduced system heating
- Easier system filtering
- Conduction or heatsink cooling

Specifications

ITEMS	MODEL	iQL				
		2.5	3.3	5	8.3	12
Nominal Output Voltage	VDC	2.5	3.3	5	8.3	12
Input Voltage Range	VDC	See Model Selector				
Ripple & Noise (max)(pk-pk) (1) mV	30	100	80	100	100	120
Line Regulation (max)	mV	5	6.6	10	30	60
Load Regulation (max)	mV	5	15	10	40	60
Overload Protection Threshold (3)	A	69	70	50	34	27.5
Overvoltage Protection (Typ) (2)	VDC	3.1	4.1	6.1	10	14.7
Overtemperature Protection (3)	-	Yes				
Remote Sense	-	Yes except 8.3V models and above				
Remote On / Off	-	Negative Logic				
Temperature (operating)	°C	-40°C to +115°C		-40°C to +125°C	-40°C to +119°C	-40°C to +118°C
Temperature (storage)	°C	-55°C to +125°C				
Humidity (operating)	-	20 to 95% (non-condensing)				
Humidity (storage)	-	10 to 95% (non-condensing)				
Cooling	-	Conduction, convection, or forced air				
Isolation Voltage	VDC	1500 Input - Output, 1500 Input - Baseplate				
Vibration (non operating)	-	5 to 50Hz@0.5g (4.9m/s ²), and 50 to 500Hz@1.5g (14.7m/s ²) per Bellcore TR-EOP-000063-5.4.4				
Shock	-	50 G at 6 ms pulse in three axes				
Safety Agency Approvals	-	UL60950 (US and Canada), VDE0805, CB scheme IEC950), CE Mark (EN60950)				
Weight (max)	g	55g open-frame, 70g with the base-plate				
Size	mm	57.9 x 36.8 x 13.21				
Warranty	yrs	3				

Notes:

- (1) Measured across one 0.1μF, one 1.0μF, one 47μF ceramic capacitor, and one 440μF electrolytic capacitor located 2 inches away. BW = 20MHz.
- (2) Latching
- (3) Non-latching



Model Selector

Model	Input Voltage (V)	Output Voltage (V)	Adjust Range (V)	Max. Curr. (A)	Max. Output Power (W)	Efficiency at Full Load (%)
IQL24024A083V-009-R	18 - 36	8.3	6.64 - 9.13	24	199	89
IQL24040A050V-009-R	18 - 36	5	4.0 - 5.5	40	200	91
IQL24050A033V-009-R	18 - 36	3.3	2.64 - 3.63	50	165	90.5
IQL48011A280V-009-R	36 - 75	28	22.4 - 30.8	11	308	92.5
IQL48025A120V-001-R	36 - 75	12	9.6 - 13.2	25	300	94
IQL48025A120V-009-R	36 - 75	12	9.6 - 13.2	25	300	94
IQL48025A120V-0B9-R	36 - 75	12	9.6 - 13.2	25	300	94
IQL48030A083V-009-R	36 - 75	8.3	n/a	30	249	90.5
IQL48045A050V-009-R	36 - 75	5	4.0 - 5.5	45	225	91
IQL48045A050V-0B9-R	36 - 75	5	4.0 - 5.5	45	225	91
IQL48060A025V-0B9-R	36 - 75	2.5	2.0 - 2.75	60	150	89
IQL48060A033V-009-R	36 - 75	3.3	2.64 - 3.63	60	198	91
IQL48060A033V-0B9-R	36 - 75	3.3	2.64 - 3.63	60	198	91

NB: other configurations on request

Recommended Footprint (Top View) iQL Series

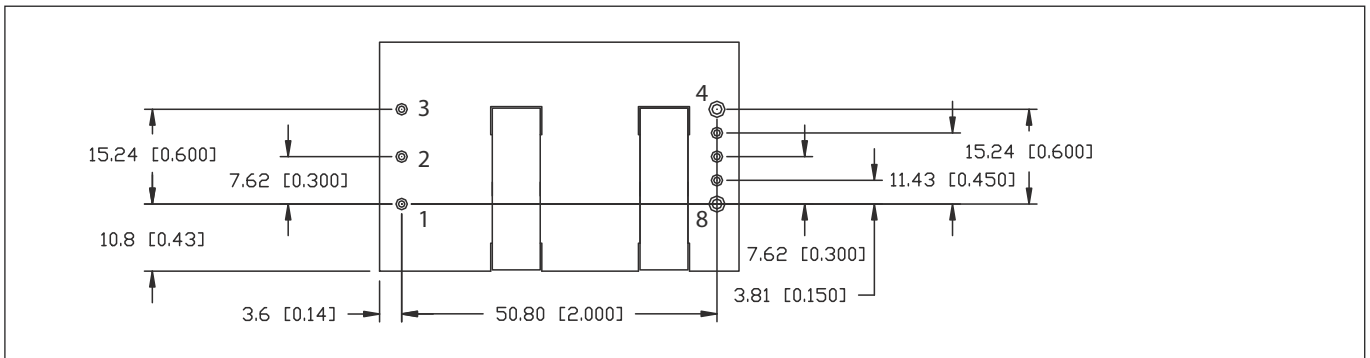

Pinout

PIN	Function	PIN	Function
1	Vin (+)	5	Sense (-) (if applicable-not fitted on 8.3V or above)
2	On / Off	6	Trim
3	Vin (-)	7	Sense (+) (if applicable-not fitted on 8.3V or above)
4	Vo (-)	8	Vo (+)

Feature Set

Feature Set	On / Off Logic	Trim Pin	Pin Length	Base Plate
00	Positive	Yes	0.145	Yes
01	Negative	Yes	0.145	Yes
08	Positive	Yes	0.180	Yes
09*	Negative	Yes	0.180	Yes
B8	Positive	Yes	0.180	No
B9	Negative	Yes	0.180	No
L8	Positive	No	0.180	Yes
L9	Negative	No	0.180	Yes

* Preferred feature set
Model Number Example: iQL48030A096V-009-R



- 60 - 160VDC Input to EN50155/IEC60571
- EN/IEC 61373 Shock and Vibration
- Base plate Cooled
- Full Power at +100°C base plate
- Five Year Warranty

Key Market Segments & Applications

- Railway Applications
- Suitable for battery powered railway systems
- Power Plants

CN-A Series

30W to 200W 110VDC Input
Quarter Brick & Half Brick Railway DC-DC Converters

CN-A Features and Benefits

Features

- Small Size
- Quarter & Half Brick Footprint
- Full Power from -40°C to +100°C
- UVLO Function

Benefits

- Less PCB space used
- Industry Standard size
- No Derating required - covers TX class for Railway
- Protects battery against deep discharges

Specifications

MODELS		CN30A110, CN50A110, CN100A110, CN200A110 See model selector			
Nominal Output Voltage	VDC	5V	12V	15V	24V
Input Voltage Range	VDC	60 - 160VDC			
Input Current	A	0.34 - 2.16A (model dependant)			
Output Voltage Adjustment	VDC	4.5 - 6	10.8 - 13.2	13.5 - 16.5	21.6 - 26.4
Ripple & Noise (max) pk-pk	mV	100	150	150	240
Line Regulation (max)	mV	20	48	60	96
Load Regulation (max)	mV	40	96	120	192
Overcurrent Protection	%	105 - 140%			
Overvoltage Protection	%	125 - 145% (Cycle input or remote on/off to reset)			
Remote Sense	-	Yes			
Remote On/Off	-	Yes; Low = ON, Open = OFF			
Parallel Operation	-	CN30-50 : No / CN200 : 5V : No; 12, 15, 24V : Yes			
Operating Temperature	°C	-40°C to +100°C Baseplate			
Storage Temperature	°C	-40°C to +100°C			
Temperature Coefficient	%/°C	0.02%/°C			
Humidity (non condensing)	%RH	5 - 95% RH Operating and Non Operating			
Cooling	-	Conduction (See Installation Manual for heatsink selection)			
Withstand Voltage	VAC	Input to Baseplate: 1.5kVAC; Input to Output 3.0kVAC for 1 min.; Output to Baseplate: 500VAC for 1 min			
Isolation Resistance	Ω	>100MΩ at 25°C and 70%RH, Output to Base plate 500VDC			
Vibration	-	Non Operating, 10-55Hz (sweep for 1 min.) Amplitude 0.825mm constant (Max 49 m/s ²) X,Y,Z 1 hour each IEC61373 - Category 1, Grade B			
Shock	-	196.1m/s ² , EN/IEC61373 - Category 1, Grade B			
Safety Agency Certifications	-	UL60950-1, CSA60950-1, EN60950-1, CE LVD			
Weight (Typ)	g	CN30-50 : 70 / CN200 : 100			
Size (WxHxD)	mm	CN30A - 100A : 36.8 x 12.7 x 57.9, CN200A : 61 x 12.7 x 57.9			
Warranty	yrs	5			

Notes: See Installation Manual for full details, test methods of parameters and application notes



Model Selector

Model	Voltage (V)	Output Current (A)	Maximum Power (W)	Input Current (A)	Efficiency (%) (100% load, 110VDC In)
CN30A110-5	5	6.0	30.0	0.34	83
CN50A110-5	5	10.0	50.0	0.55	85
CN100A110-5	5	20.0	100.0	1.08	85
CN200A110-5	5	40.0	200.0	2.16	85
CN30A110-12	12	2.5	30.0	0.34	84
CN50A110-12	12	4.2	50.4	0.55	86
CN100A110-12	12	8.4	100.8	1.05	88
CN200A110-12	12	16.7	200.4	2.09	88
CN30A110-15	15	2.0	30.0	0.34	84
CN50A110-15	15	3.4	51.0	0.55	86
CN100A110-15	15	6.7	100.5	1.05	88
CN200A110-15	15	13.4	201	2.1	88
CN30A110-24	24	1.3	31.2	0.34	84
CN50A110-24	24	2.1	50.4	0.55	86
CN100A110-24	24	4.2	100.8	1.05	88
CN200A110-24	24	8.4	201.6	2.11	88

Outline Drawing CN30A-CN100A

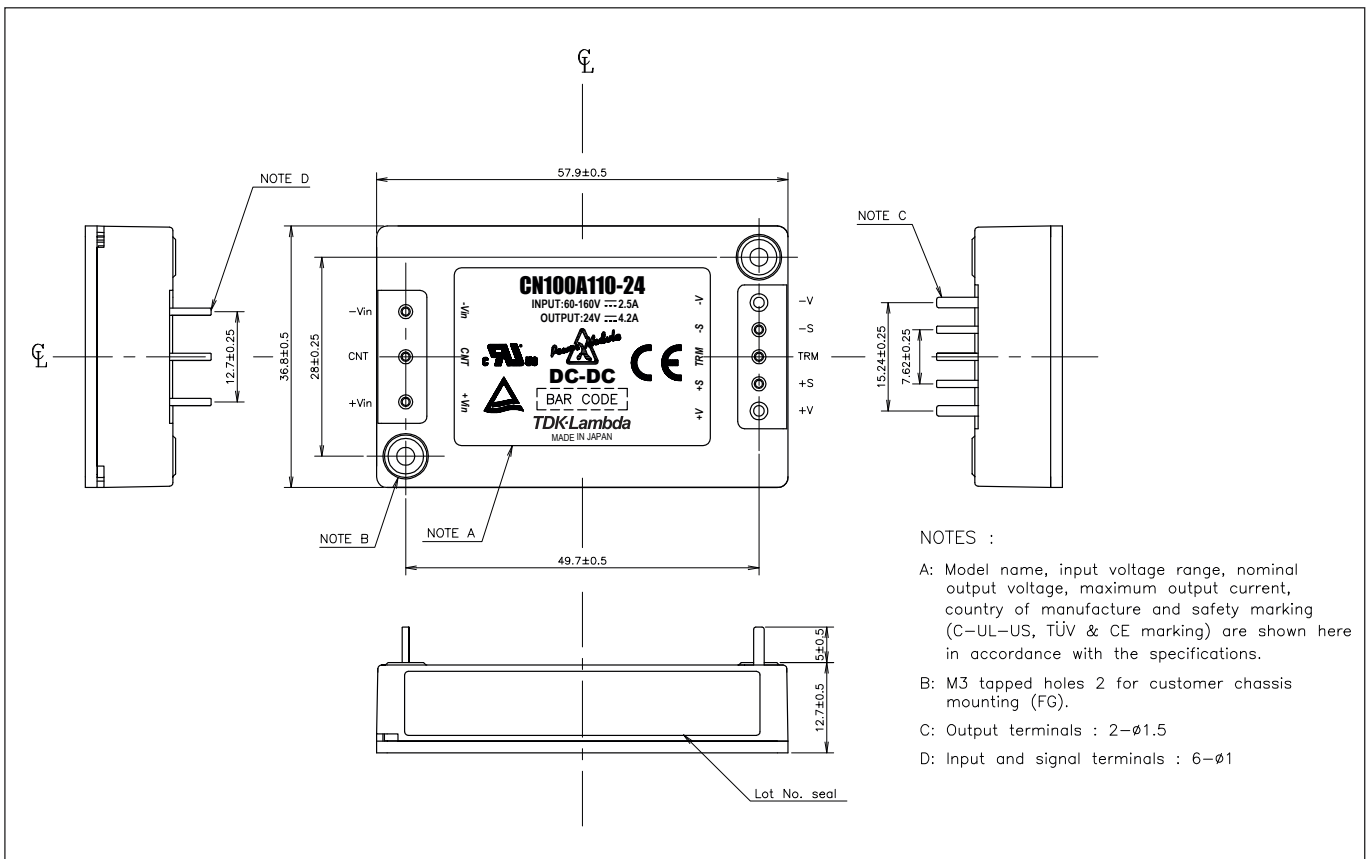



Outline Drawing CN200A

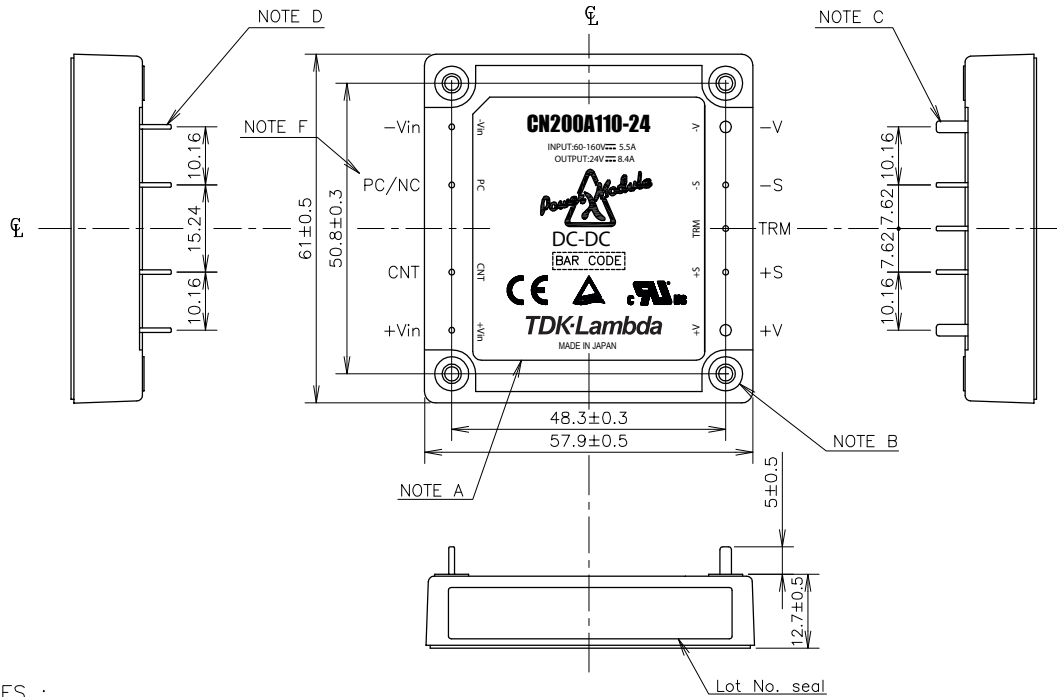

NOTES :

- A: Model name, input voltage range, nominal output voltage, maximum output current, country of manufacture and safety marking (C-UL-US, TÜV & CE marking) are shown here in accordance with the specifications.
- B: M3 tapped holes 4 for customer chassis mounting (FG).
- C: Output terminals : 2- ϕ 2.0
- D: Input and signal terminals : 7- ϕ 1
- E: Unless otherwise specified dimensional tolerance : ± 0.25
- F: 5V output model : NC
12V, 15V, 24V output models : PC

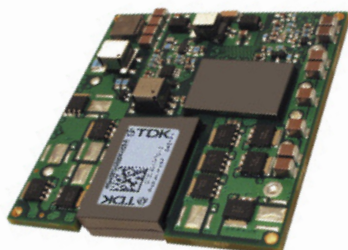

- Standard Half Brick Footprint (DOSA)
- 36 - 75VDC Input
- 3.3V 30A - 5V 60A Nominal Outputs
- Through Hole Mounting
- 1500VDC Basic Isolation

iHG Series

50 - 300W, 48V Input
Half Brick Converter

iHG Features and Benefits

Features

- High operating efficiency (up to 92.5%)
- Constant switching frequency
- Low component count

Benefits

- Reduced system heating
- Easier system filtering
- Higher reliability

Specifications

MODEL		iHG48030A033V-002-R	iHG48070A033V-001-R	iHG48010A050V-002-R	iHG48060A050V-002-R
ITEMS					
Nominal Output Voltage	VDC	3.3	3.3	5	5
Input Voltage Range	VDC	36 - 75			
Efficiency	%	92.5	90	89	91
Ripple & Noise (max)(pk-pk) (1)	mV	50	50	60	60
Line Regulation (max)	mV	10	10	10	12
Load Regulation (max)	mV	10	10	10	12
Overload Protection Threshold (3)	A	38	82	13.8	70
Overvoltage Protection (2)	VDC	4.1	4.1	6.1	6.1
Overtemperature Protection (3)	-	Yes			
Remote Sense	-	yes			
Remote On-Off	-	Positive or Negative Logic Available, see Model Selector			
Temperature (operating)	°C	-40°C to +115°C	-40°C to +123°C	-40°C to +125°C	-40°C to +125°C
Temperature (storage)	°C	-55°C to +125°C			
Humidity (operating)	-	20 to 95% (non-condensing)			
Humidity (storage)	-	10 to 95% (non-condensing)			
Cooling	-	Convection or Forced Air			
Isolation Voltage	VDC	1500			
Vibration (non operating)	-	5 to 50Hz@0.5g (4.9m/s ²), and 50 to 500Hz@1.5g (14.7m/s ²) per Bellcore TR-EOP-000063-5.4.4			
Shock	-	50 G at 6ms pulse in three axes			
Safety Agency Approvals	-	UL60950 (US and Canada), VDE0805, CB scheme (IEC950), CE Mark (EN60950)			
Weight (max)	g	63			
Size	mm	59.94 x 56.90 x 11.68			
Warranty	yrs	3			

Notes:

- (1) Measured across one 10 μ f, one 0.47 μ f, one 0.1 μ f ceramic capacitors, and one 220 μ f electrolytic capacitor. BW = 20MHz.
- (2) Latching
- (3) Non-latching



Model Selector

Model	Input Volt. (V)	Output Volt. (V)	Adjust Range (V)	Output Current (A)	Max. Output Power (W)	On/Off Logic	Pin Length (in)
iHG48010A050V-002-R	36 - 75	5	2.5 - 5.5	10	50	P	0.145
IHG48030A033V-002-R	36 - 75	3.3	1.65 - 3.63	30	99	P	0.145
IHG48060A018V-003-R	36 - 75	1.8	0.9 to 1.98	60	108	N	0.145
IHG48060A050V-002-R	36 - 75	5	2.5 - 5.5	60	300	P	0.145
IHG48070A033V-001-R	36 - 75	3.3	1.65 - 3.63	70	231	N	0.145

NB other configurations on request

Hole Pattern (Top View) iHG

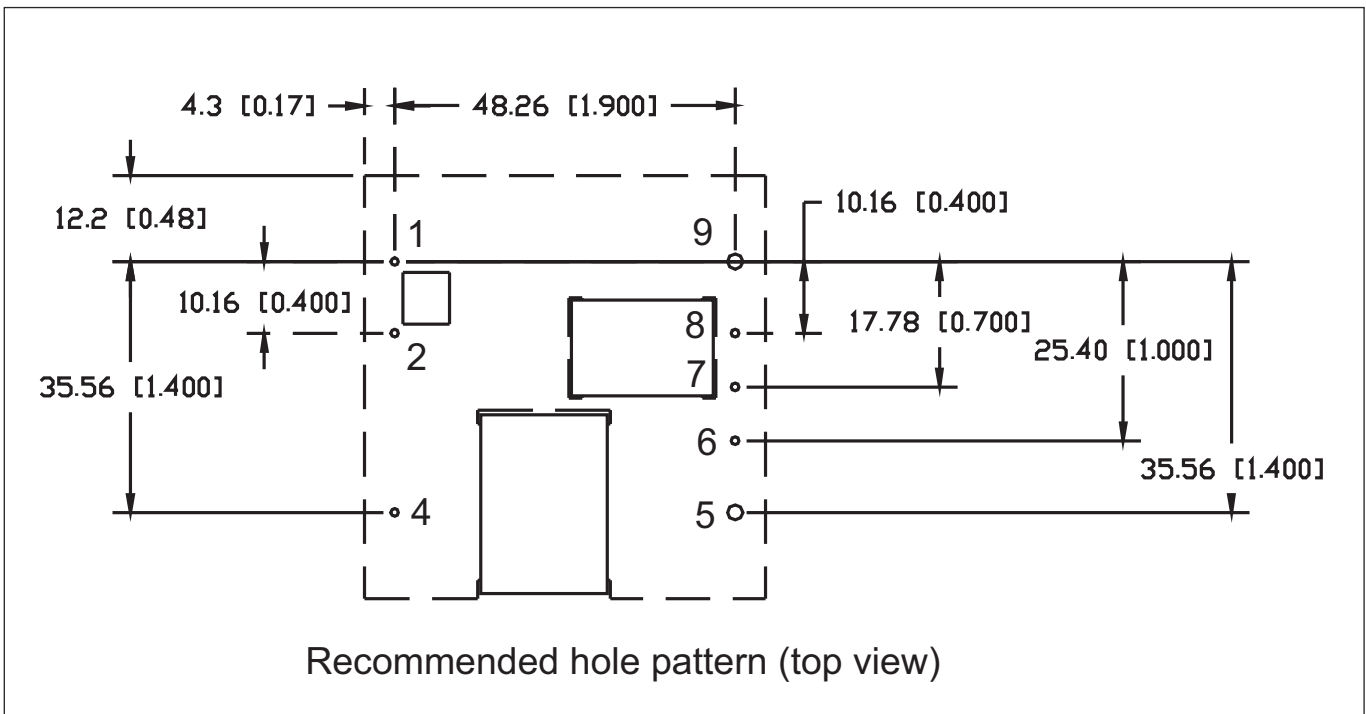

Pinout			
PIN	Function	PIN	Function
1	Vin (+)	6	Sense (-)
2	On / Off	7	Trim
3	N / A	8	Sense (+)
4	Vin (-)	9	Vout (+)
5	Vout (-)		



PAH Series

48V Input Half brick
DC-DC Converters

- Industry Standard Footprint & Pinouts
- 12V output for driving non-isolated converters
- Safety Approved
- Full power at +100°C baseplate
- Wide Adjustable Output Range

Key Market Segments & Applications

- Central Office: ATM, Sonet, DSL, ISDN, Frame relay
- Broadband: Switching Equipment, Routers
- Wireless/Cellular: Micro Cells (larger in size/10 sq. mi.)
Pico Cells (smaller in size/1 to 2 sq. mi.)
- Remote Electronics: Fixed Local Loop, Fiber Optic
Transmission, Microwave Transmission,
Wireless Local Loop
- Customer Premise: PBX, PABX, Datacomm, Voice Systems,
Video Conferencing

PAH Features and Benefits

Features

- Wide adjustment range
- Zero Pre-load
- ASIC Design
- No potting materials

Benefits

- Reduces need for custom modules
- Eliminates heat dissipation in system
- Reduced component count, increased MTBF
- Lower weight

Specifications

MODELS		2.5V	3.3V	5V	12V	15V	24V	28V	48V
ITEMS									
Efficiency (Typ)	%	75-76	79-80	83-84	85-86		86-88		88
Input Voltage range	VDC	36-76							
Output Voltage Accuracy	%	±1.6							
Max Ripple & Noise	mV	150			200		240	280	250
Max Line Regulation	mV	10			24	30	48	56	96
Max Load Regulation	mV	10			24	30	48	56	96
Overcurrent Protection	A	105 - 150% automatic recovery							
Overvoltage Protection (1)	%	120-160	120-140	125-145				135-155	
Remote Sense	-	Yes							
Remote On/Off	-	Standard; Low = ON, Open = OFF /P option; Low = OFF, Open = ON)							
Operating Temperature	-	-40°C to +100°C baseplate							
Overtemperature	-	Shutdown between 105°C to 130°C, Auto restart							
Cooling	-	Conduction (See Installation Manual for heatsink selection)							
Isolation Voltage	V	Input - Baseplate 1500VAC, Input - Output 1500VAC, Output-Baseplate 500VDC							
Shock	-	196.1m/s ²							
Vibration	-	Non Operating, 10-55Hz (sweep for 1 min.)							
Amplitude	-	0.825mm constant (Max 49 m/s ²) X,Y,Z 1 hour each							
Safety Agency Approvals	-	UL60950-1, CSAC22.2 No.60950-1, EN60950-1, CE LVD							
Weight (Typ)	g	80							
Size (WxHxD)	in(mm)	2.28x0.5x2.4 (57.9x12.7x61) See outline drawing							
Warranty	yrs	2							

Notes: (1) See options table. General: See Installation Manual for full details, test methods of parameters and application notes



Model Selector				
Model Name	Output Voltage	Adjustment	Output Current	Maximum Power
PAH50S48-2.5	2.5	2.25 - 2.75	11.70	29.3
PAH75S48-2.5	2.5	2.25 - 2.75	17.50	43.8
PAH100S48-2.5	2.5	2.25 - 2.75	23.40	58.5
PAH150S48-2.5	2.5	2.25 - 2.75	35.00	87.5
PAH50S48-3.3	3.3	2.97 - 3.63	11.70	38.6
PAH75S48-3.3	3.3	2.97 - 3.63	17.50	57.8
PAH100S48-3.3	3.3	2.97 - 3.63	23.40	77.2
PAH150S48-3.3	3.3	2.97 - 3.63	35.00	115.5
PAH50S48-5	5.0	3.0 - 5.75	10.00	50.0
PAH75S48-5	5.0	3.0 - 5.75	15.00	75.0
PAH100S48-5	5.0	3.0 - 5.75	20.00	100.0
PAH150S48-5	5.0	3.0 - 5.75	30.00	150.0
PAH50S48-12	12.0	7.2 - 13.2	4.20	50.4
PAH75S48-12	12.0	7.2 - 13.2	6.30	75.6
PAH100S48-12	12.0	7.2 - 13.2	8.40	100.8
PAH150S48-12	12.0	7.2 - 13.2	12.50	150.0
PAH200S48-12	12.0	7.2 - 13.2	16.70	200.4
PAH50S48-15	15.0	9.0 - 16.5	3.40	51.0
PAH75S48-15	15.0	9.0 - 16.5	5.00	75.0
PAH100S48-15	15.0	9.0 - 16.5	6.70	100.5
PAH150S48-15	15.0	9.0 - 16.5	10.00	150.0
PAH200S48-15	15.0	9.0 - 16.5	13.40	201.0
PAH50S48-24	24.0	14.4 - 26.4	2.10	50.4
PAH75S48-24	24.0	14.4 - 26.4	3.20	76.8
PAH100S48-24	24.0	14.4 - 26.4	4.20	100.8
PAH150S48-24	24.0	14.4 - 26.4	6.30	151.2
PAH200S48-24	24.0	14.4 - 26.4	8.40	201.6
PAH50S48-28	28.0	16.8 - 30.8	1.80	50.4
PAH75S48-28	28.0	16.8 - 30.8	2.70	75.6
PAH100S48-28	28.0	16.8 - 30.8	3.60	100.8
PAH150S48-28	28.0	16.8 - 30.8	5.40	151.2
PAH200S48-28	28.0	16.8 - 30.8	7.20	201.6
PAH150S48-48	48.0	38.4 - 57.6	3.20	153.6

Options		
Suffix	ON/OFF Control	Overvoltage
-	Negative	Manual Reset
/P	Positive	Manual Reset
/V*	Negative	Auto Reset
/PV	Positive	Auto Reset

Note: * Standard US Stock Item.



Outline Drawing PAH150S

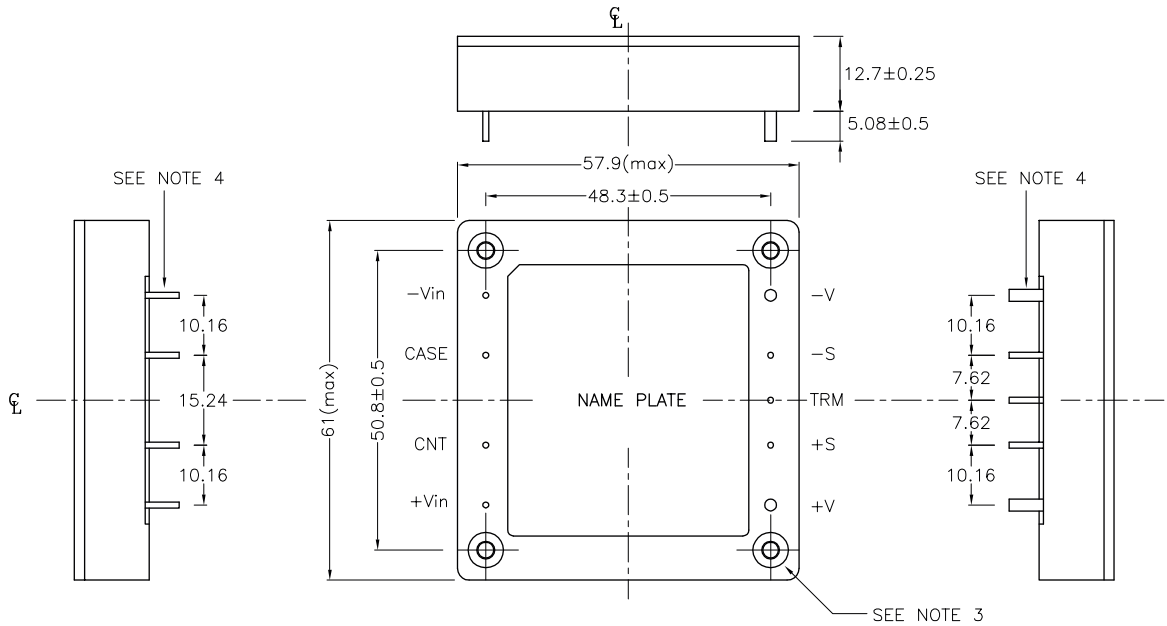

NAME PLATE :

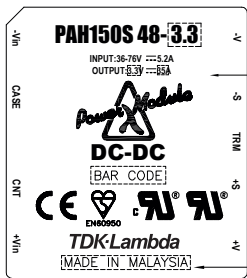

NOTE :

1. MODEL NAME, INPUT VOLTAGE RANGE, MAXIMUM INPUT CURRENT, NOMINAL OUTPUT VOLTAGE AND MAXIMUM OUTPUT CURRENT ARE SHOWN HERE IN ACCORDANCE WITH THE SPECIFICATIONS.
2. COUNTRY OF MANUFACTURE WILL BE SHOWN HERE.
3. M3 TAPPED HOLES (4) FOR CUSTOMER CHASSIS MOUNTING.
4. INPUT AND OUTPUT TERMINAL : 2- ϕ 2 (+V, -V)
7- ϕ 1 (OTHER PINS)
5. UNLESS OTHERWISE SPECIFIED DIMENSIONAL TOLERANCE : ± 0.25

Pinout

Pin Description	Function
-Vin	Negative Input Terminal
+Vin	Positive Input Terminal
Case	Baseplate Terminal
CNT	On / Off Control terminal
+V	Positive Output Terminal
-V	Negative Output Terminal
TRIM	Output adjustment Trim pin
+S	Positive Remote sense
-S	Negative Remote sense



- 12V output for driving non-isolated converters
- Safety Approved
- Operation at +100°C baseplate
- Wide Adjustable Output Range
- Industry Standard Half Brick Package

Key Market Segments & Applications

Base Station Power Amplifiers
 Bus converters for Distributed Power Architectures

PAH300/450 Series

300W to 450W 24V & 48V Input Half Brick DC-DC Converters

PAH Features and Benefits

Features

- Wide adjustment range
- Compact size
- ASIC Design
- 24V & 48V inputs

Benefits

- Reduces need for custom modules
- Replaces 3/4 or Full Brick Power Modules
- Reduced component count, increased MTBF
- Suitable for remote & central office applications

Specifications

ITEM	MODELS	PAH300S, 350S, 450S		
		12V	28V	48V
Nominal Output Voltage	VDC	12V	28V	48V
Input Voltage range	VDC	18-36 or 36-76		
Input Current (Max)	A	8.24-17.4A (model dependant)		
Output Voltage Adjustment	VDC	7.2 - 13.2	16.8 - 33	28.8 - 57.6(5)
Ripple & Noise (max) (pk to pk)	mV	200	280(1)	480
Line Regulation (max)	mV	24	56	96
Load Regulation (max)	mV	24	56	96
Overload Protection	%	105 - 140%, constant current with auto recovery		
Overvoltage Protection (3)	%	115-135%	125-140%(2)	125-145%(6)
Remote Sense	-	Yes		
Remote On/Off (See options)	-	Standard; Low = ON, Open = OFF /P option; Low = OFF, Open = ON		
Temperature (operating)	°C	-40°C to +100°C baseplate, full power(4)		
Temperature (storage)	°C	-40°C to +100°C		
Temperature Coefficient	-	0.02%/°C		
Humidity (operating)	-	5 - 95% RH Non condensing		
Humidity (storage)	-	5 - 95% RH Non condensing		
Cooling	-	Conduction (See Installation Manual for heatsink selection)		
Isolation Voltage	VDC	1500VDC Input to output & baseplate, 500VDC Output to baseplate		
Vibration	-	Non Operating, 10-55Hz (sweep for 1 min.)		
Amplitude	-	0.825mm constant (Max 49 m/s ²) X,Y,Z 1 hour each		
Shock	-	196.1m/s ²		
Safety Agency Approvals	-	UL60950-1, CSA60950-1, EN60950-1, CE LVD (48V input models only)		
Weight (Typ)	g	90/100		
Size (WxHxD)	mm	61x12.7x57.9 See outline drawing		
Warranty	yrs	2		

Note: See Installation Manual for full details, test methods of parameters and application notes

(1) 240mV for PAH300

(2) 125-145% for PAH450S48-28

(3) Manual reset

(4) PAH350S24-28 & -48 derate linearly to 85% load from 90°C to 100°C

(5) 28.8-52.8 PAH350S24-48

(6) 115-140% PAH350S24-48

**Model Selector**

Model	Input Voltage (V)	Output Voltage (V)	Max. Curr. (A)	Max. Output Power (W)	Efficiency Typ. (%)
PAH300S24-12	18 - 36	12	25	300	87
PAH300S48-12	36 - 76	12	25	300	90
PAH350S48-12	36 - 76	12	29.2	350	89
PAH300S24-28	18 - 36	28	11	308	88
PAH350S24-28	18 - 36	28	12.5	350	88
PAH350S24-48	18 - 36	48	7.3	350	87
PAH300S48-28	36 - 76	28	11	308	90
PAH350S48-28	36 - 76	28	12.5	350	89
PAH450S48-28	36 - 76	28	16	448	92
PAH450S48-48	36 - 76	48	9.4	451	92

Pinout

Pin Description	Function
-Vin	Negative Input Terminal
+Vin	Positive Input Terminal
CNT	On / Off Control terminal
+V	Positive Output Terminal
-V	Negative Output Terminal
TRIM	Output adjustment Trim pin
+S	Positive Remote sense
-S	Negative Remote sense

Options

Suffix	Description
-	M3 Tapped inserts for mounting
/T	M3 clearance inserts for mounting
/P	Positive logic remote On/Off



Outline Drawing PAH300/450 Series

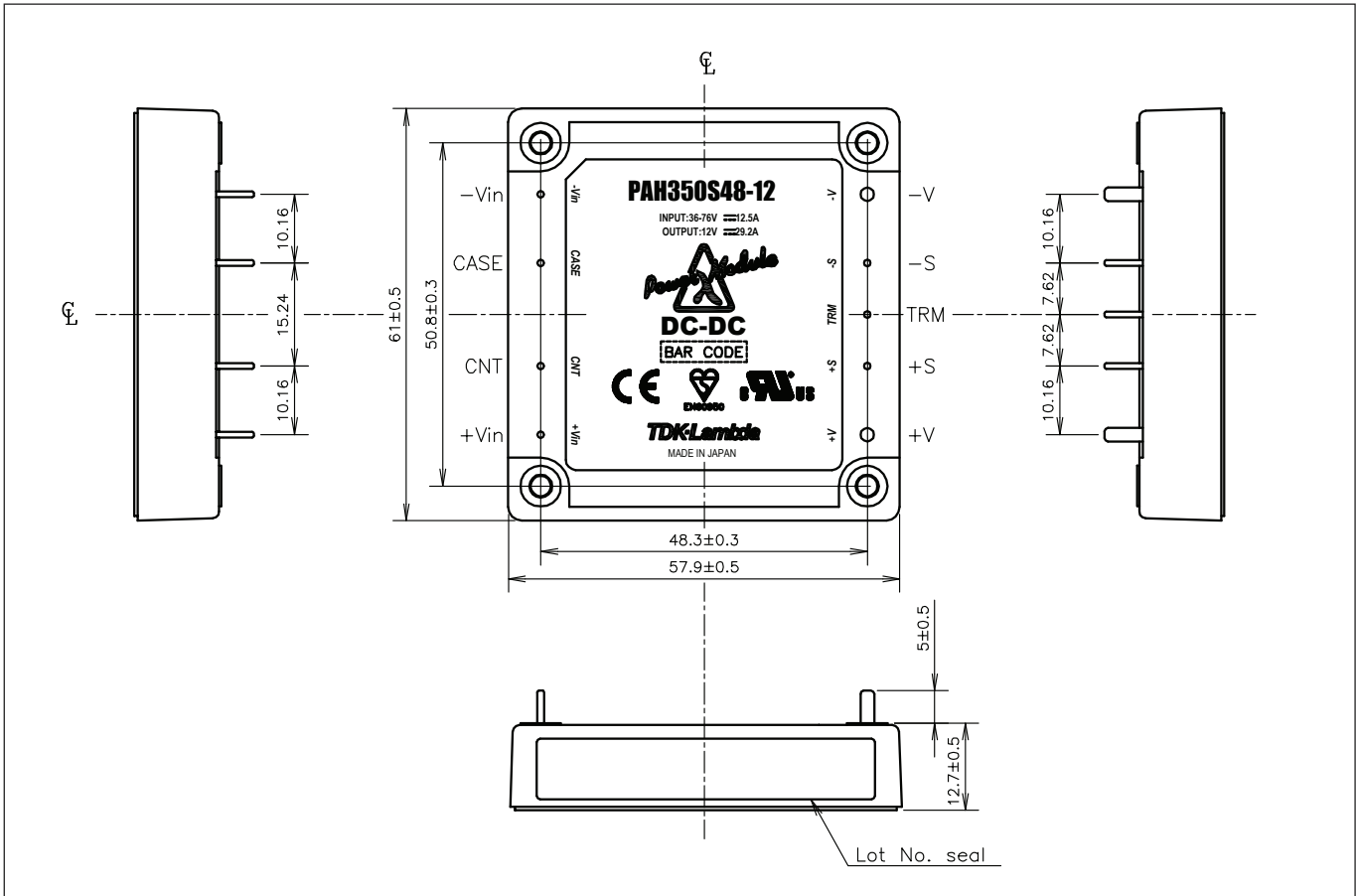



PAF500F PAF600F

24V & 48V Input Full Brick DC-DC Converters

- Includes 12V output models for driving non-isolated converters
- Up to 80A output current (48V models)
- Full power at +100°C baseplate
- Opto Isolated Remote On / Off
- Wide Adjustable Output Range

Key Market Segments & Applications

Central Office:	ATM, Sonet, DSL, ISDN, Frame relay
Broadband:	Switching Equipment, Routers
Wireless/Cellular:	Micro Cells, Pico Cells
Remote Electronics:	Fixed Local Loop, Fibre Optic Transmission, Microwave Transmission, Wireless Local Loop
Customer Premise:	PBX, PABX, Datacomm, Voice Systems, Video Conferencing

PAF500F & PAF600F Features and Benefits

Features

- Wide adjustment range
- Parallel Pin
- ASIC Design
- 24V and 48V Inputs

Benefits

- Reduces need for custom modules
- Modules can be connected together for higher current
- Reduced component count, increased MTBF
- Suitable for Industrial and Telecom Applications

Specifications

ITEMS	MODEL	PAF500F48-3.3	PAF500F48-5	PAF500F24-12	PAF500F24-28	PAF600F24-12	PAF600F24-28
		PAF500F48-12	PAF500F48-12	PAF500F48-28	PAF600F48-12	PAF600F48-28	
Nominal Output Voltage	VDC	3.3	5	12	28	12	28
Output Current (Max)	A	80	80	42	18	50	21.5
Max Output Power	W	264	400	504	504	600	602
Efficiency (Typ)	%	78	83	89	90	89-90	89-90
Input Voltage range	VDC	36-76		19-36 or 36-76	18-36 or 36-76	20-36 / 36-76	19-36 / 36-76
Input Current (Typ) (24V/48V)	A	7.3	10.4	24 / 12.2	23.8 / 12.1	28.9 / 14.2	28.9 / 14.1
Output Voltage Accuracy	%	±1					
Output Voltage Adjustment	VDC	2 - 4	3 - 6	7.2 - 13.2	16.8 - 30.8	7.2 - 13.2	16.8 - 30.8
Max Ripple & Noise	mV	100	100	200	280	200	280
Max Line Regulation	mV	10	10	24	56	24	56
Max Load Regulation	mV	10	10	24	56	24	56
Overcurrent Protection	%	105 - 140%					
Overvoltage Protection	%	130-160	125-145	115-135	115-135	115-135	115-135
Signals & Control	-	Remote sense, remote On/Off, Parallel Pin, DC Good (12, 28V models) Adjustable OVP (3.3, 5V models), 7-10V Auxiliary voltage				Remote sense, remote On/Off, Parallel Pin DC Good, 7-10V Auxiliary voltage	
Operating Temperature	-	-40°C to +100°C baseplate					
Cooling	-	Conduction (See Installation Manual for heatsink selection)					
Isolation Voltage	VDC	Input - Baseplate 1500V, Input - Output 1500V, Output-Baseplate 500V					
Shock	-	196.1m/s ²					
Vibration	-	Non Operating, 10-55Hz (sweep for 1 min.) Amplitude 0.825mm constant (Max 49m/s ²) X, Y, Z 1 hour each					
Safety Agency Approvals	-	UL60950-1, CSA60950-1, EN60950-1, CE LVD					
Weight (Typ)	g	250					
Size (WxHxD)	mm	61 x 12.7 x 116.8 See outline drawing					
Warranty	yrs	2					

Notes: See Installation Manual for full details, test methods of parameters and application notes.



Pinout	
Pin Description	Function
-Vin	Negative Input Terminal
+Vin	Positive Input Terminal
- ON/OFF	Remote On/Off negative terminal
+ON/OFF	Remote On/Off positive terminal
+V	Positive Output Terminal
-V	Negative Output Terminal
AUX	7-10V Aux voltage
IOG/OVP	DC Good / OVP adjustment
PC	Parallel control connection
TRIM	Output adjustment Trim pin
+S	Positive Remote sense
-S	Negative Remote sense

Options	
Suffix	Description
Blank	
/T	No thread in mounting holes

Heatsink Table		
Heatsink	Size (mm)	Thermal Resistance
HAF-10L	116.8 x 25.4 x 61	2.2°C/W
HAF-15L	116.8 x 38.1 x 61	1.9°C/W
HAF-15T	116.8 x 38.1 x 61	1.5°C/W

Outline Drawing PAF500F

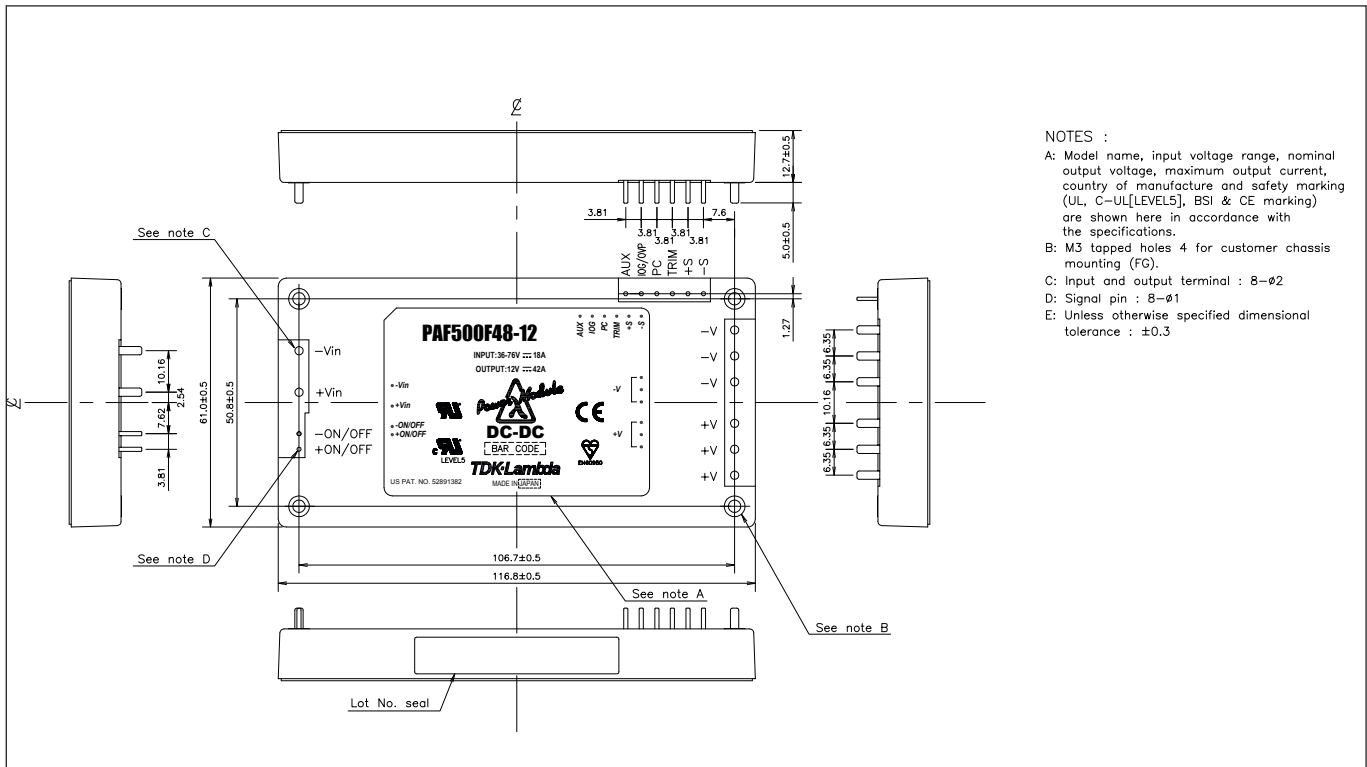



Outline Drawing PAF600F

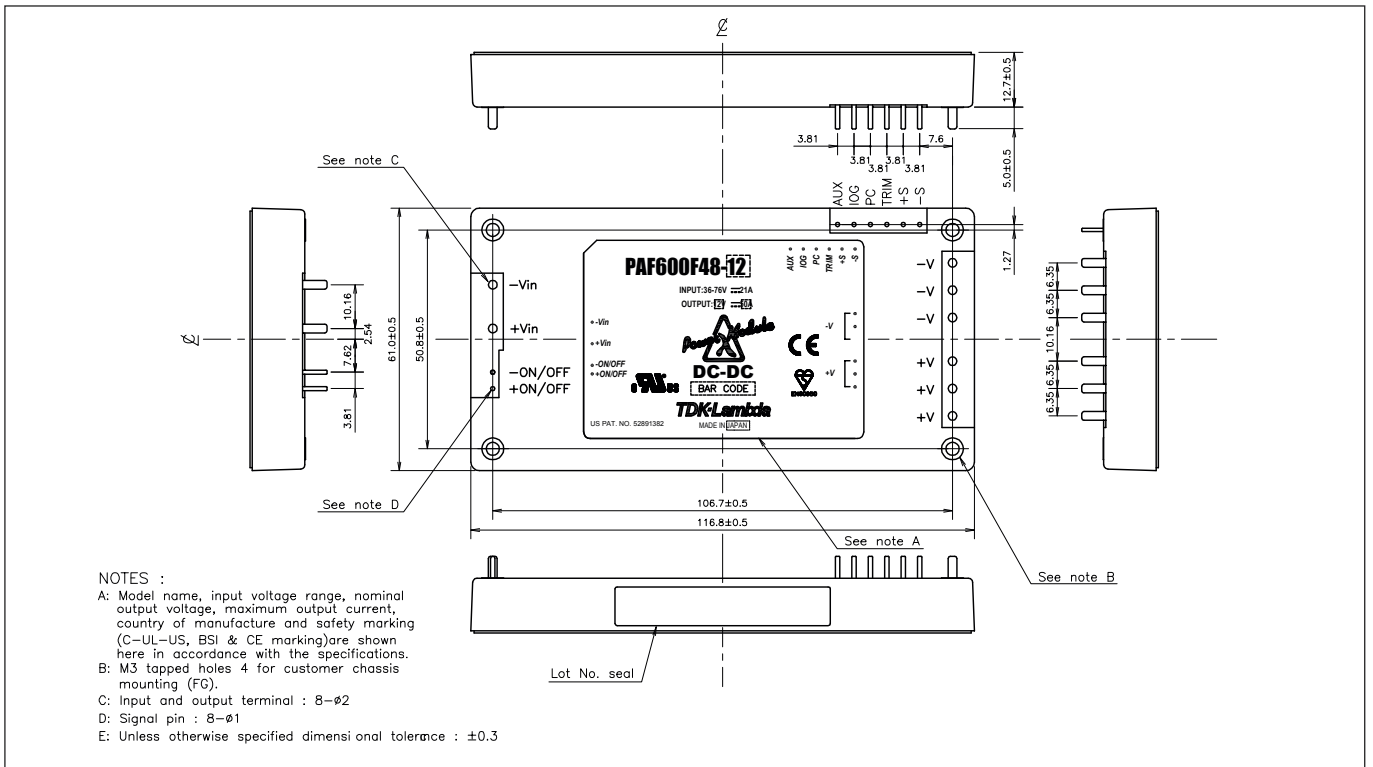

Connection Example

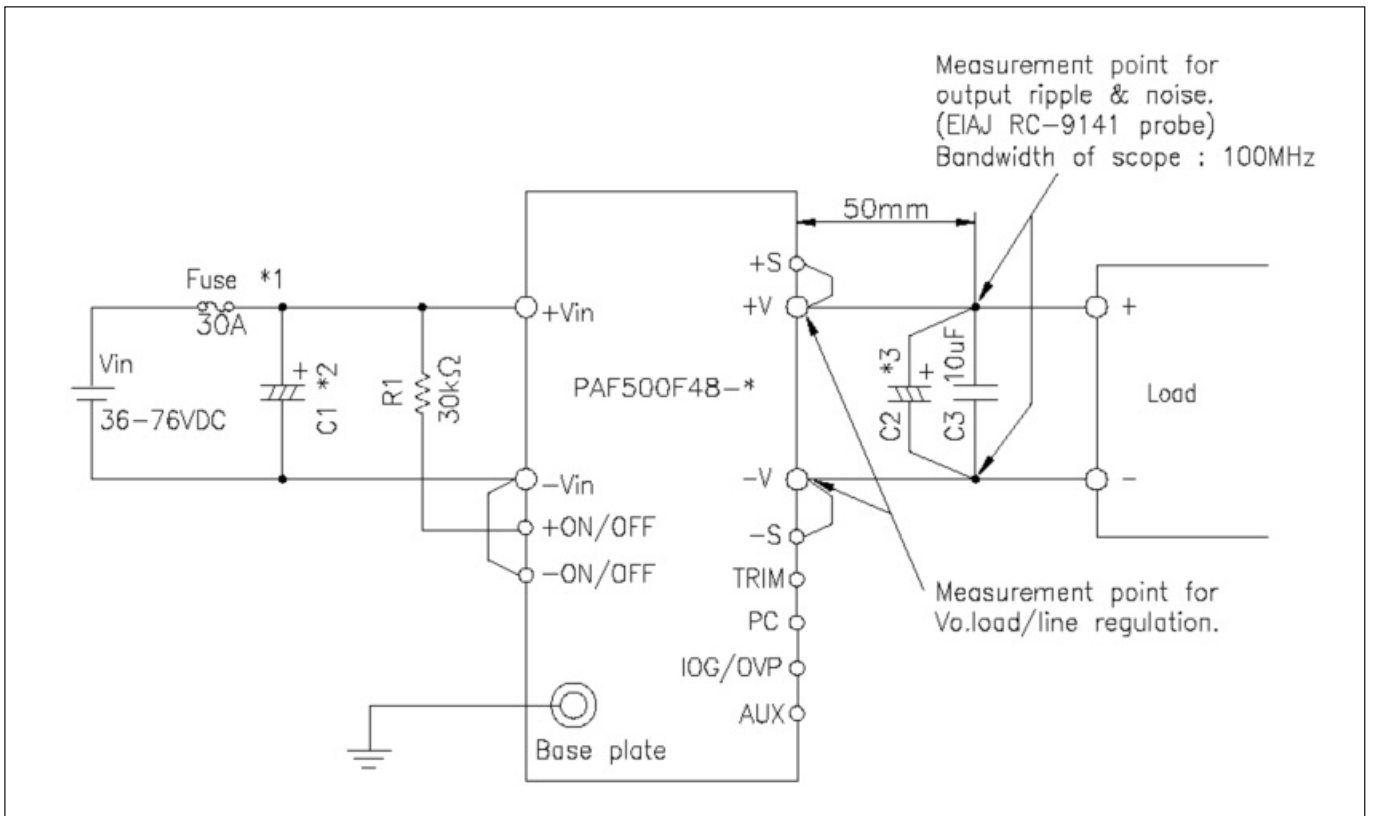



- Output Voltages from 7.2V to 57V
- Current Share
- Operation to +100°C Baseplate
- Wide Adjustable Output Range

Key Market Segments & Applications

- Servers & Rail Systems
- High End Computers
- Customer Power Supplies

PAF450F280 & PAF600F280

200V to 400VDC Input Full Brick
DC-DC Converters

PAF450F280 & PAF600F280 Features and Benefits

Features

- Wide adjustment range
- Parallel Pin
- High efficiency - up to 91%

Benefits

- Reduces need for custom modules
- Modules can be connected together for higher current
- Reduces Heat Loss

Specifications

MODEL		PAF600F280-12 /PAF450F280-12	PAF600F280-24 /PAF450F280-24	PAF600F280-28 /PAF450F280-28	PAF600F280-48 /PAF450F280-48
ITEMS					
Nominal Output Voltage	VDC	12	24	28	48
Output Current (Max)	A	50/38	25/19	21.5/16.5	12.5/9.5
Max Output Power	W	600/456	600/456	602/462	600/456
Efficiency (Typ)	%	89/90	91	91	91
Input Voltage Range	VDC	200-400VDC			
Output Voltage Accuracy	%	±1			
Output Voltage Adjustment	VDC	7.2 - 14.4	14.4 - 28.8	16.8 - 33.6	28.8 - 57.6
Max Ripple & Noise	mV	120	240	280	480
Max Line Regulation	mV	48	56	56	96
Max Load Regulation	mV	48	56	56	96
Temperature Coefficient	°C	0.02%/°C			
Overcurrent Protection	%	105 - 140%			
Overvoltage Protection	%	125 - 145%			
Signals & Control	-	Remote sense, remote On/Off, Parallel Pin, Inverter Good, 10-14V Auxiliary voltage			
Baseplate Temperature	-	-40°C to +100°C Baseplate: (See derating chart)			
Humidity (non condensing)	-	5 - 95% RH Operating, 5 - 95% RH Non Operating			
Cooling	-	Conduction (See Installation Manual for heatsink selection)			
Isolation Voltage	-	Input to Baseplate: 2500VAC (20mA); Input to Output 3000VAC for 1 min.; Output to Baseplate: 500VDC for 1 min			
Shock	-	196.1m/s ²			
Vibration	-	Non Operating, 10-55Hz (sweep for 1 min.) Amplitude 0.825mm constant (Max 49 m/s ²) X,Y,Z 1 hour each			
Safety Agency Approvals	-	UL60950-1, CSA60950-1, EN60950-1, CE LVD			
Weight (Typ)	g	200			
Size (WxHxD)	mm	61 x 12.7 x 116.8			
Warranty	yr	2			

Notes: See Installation Manual for full details, test methods of parameters and application notes.



Pinout

Pin Description	Function
-Vin	Negative Input Terminal
+Vin	Positive Input Terminal
CNT	Remote On/Off Negative Terminal
+V	Positive Output Terminal
-V	Negative Output Terminal
AUX	10-14V Aux Voltage
PC	Parallel Control Connection
TRIM	Output Adjustment Trim Pin
+S	Positive Remote Sense
-S	Negative Remote Sense
SG	Remote ON/OFF Return

Options

Suffix	Description
Blank	M3 tapped mounting inserts (4)
/T	3.3mm non-threaded inserts (4)

Outline Drawing PAF450F280

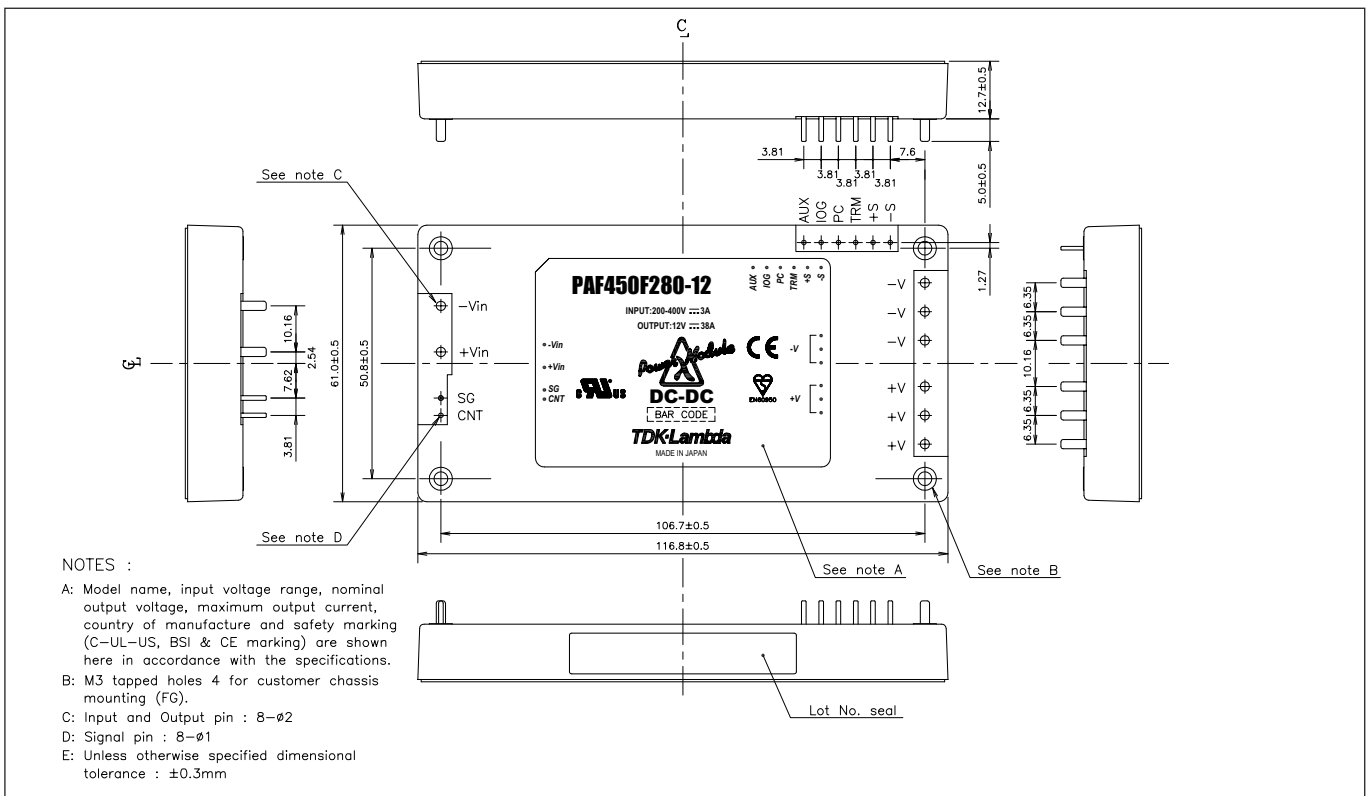

Derating Curve PAF450F280

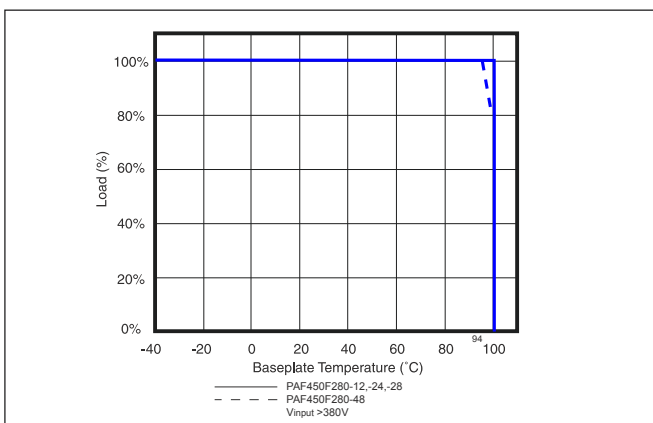

Derating Curve PAF600F280

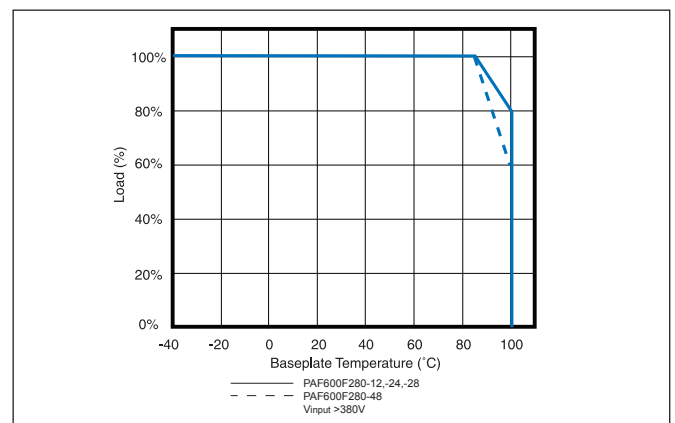



Outline Drawing PAF600F280

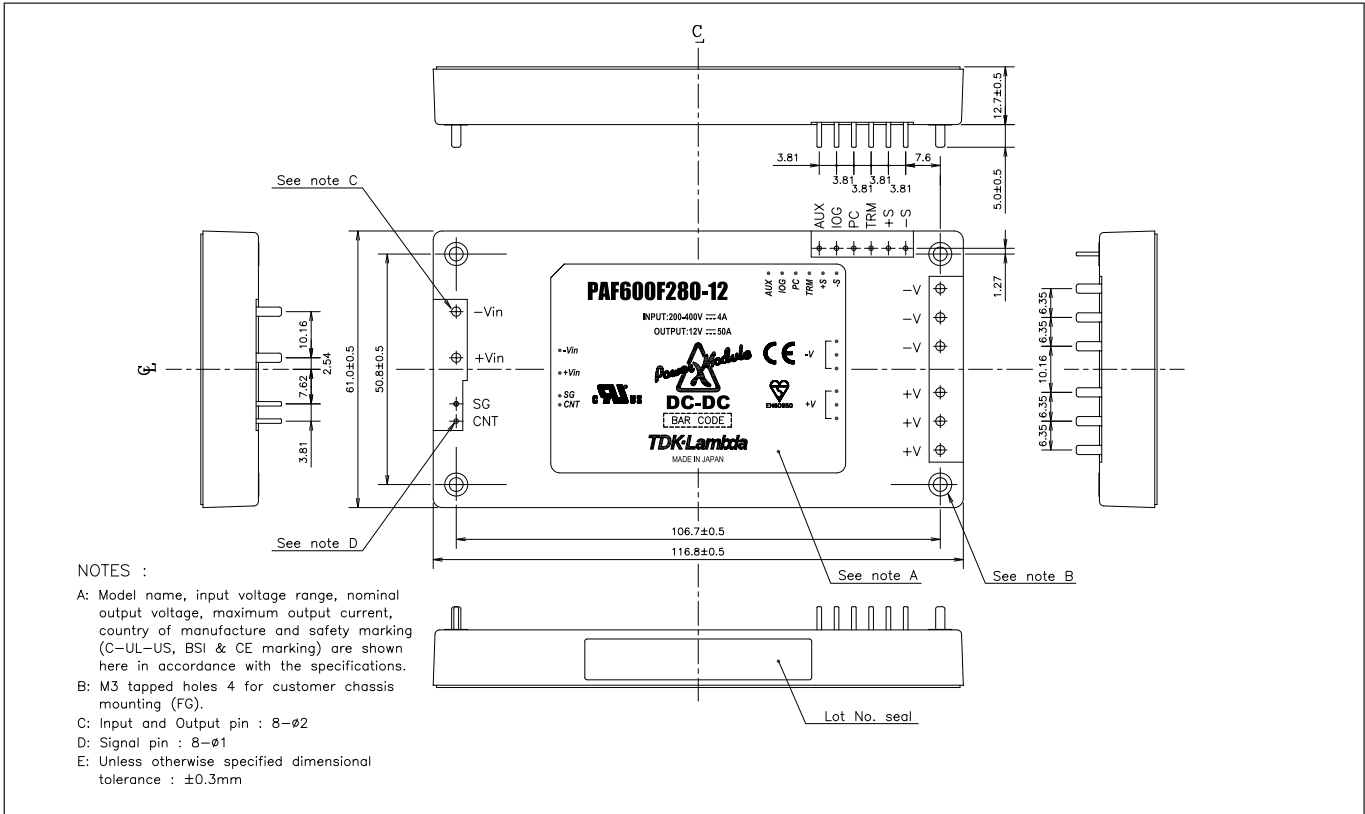

Connection Example

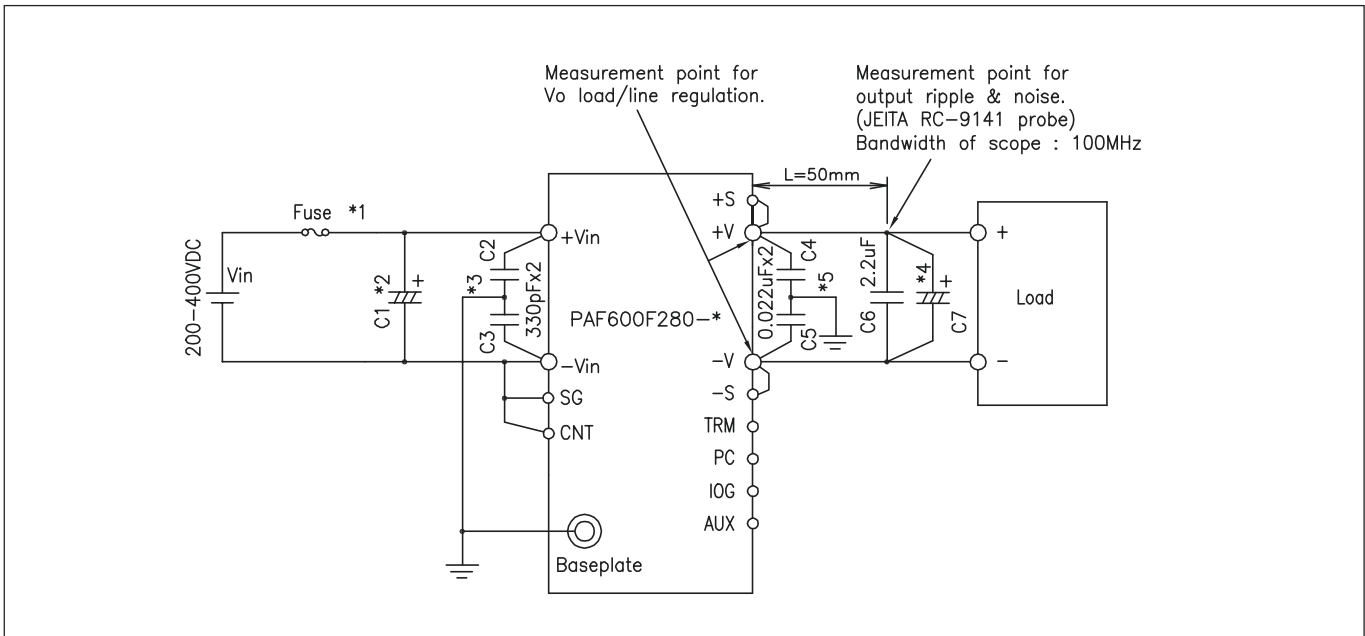



PAF700F Series

700W 48V Input
Full Brick DC-DC Converters

- 12V output for driving non-isolated converters
- 12V, 28V output for BTS amps
- Full power at +85°C baseplate, operation to +100°C
- Opto Isolated Remote On / Off
- Wide Adjustable Output Range

Key Market Segments & Applications

- | | |
|--------------------------------|---|
| Central Office: | ATM, Sonet, DSL, ISDN, Frame Relay |
| Broadband: | Switching Equipment, Routers |
| Wireless/Cellular: | Micro Cells (larger in size/10 sq. mi.)
Pico Cells (smaller in size/1 to 2 sq. mi.) |
| Remote Electronics: | Fixed Local Loop, Fibre Optic
Transmission, Microwave Transmission,
Wireless Local Loop |
| Base Station Power Amplifiers | |
| Intermediate Bus Architectures | |

PAF700F Features and Benefits

Features

- Wide adjustment range
- Parallel Pin
- ASIC Design

Benefits

- Reduces need for custom modules
- Modules can be connected together for higher current
- Reduced component count, increased MTBF

Specifications

MODEL		PAF700F48-12	PAF700F48-28
ITEMS			
Nominal Output Voltage	VDC	12	28
Output Current (Max)	A	58.5	25
Output Power (Max)	W	702	700
Efficiency (Typ)	%	90%	91%
Input Voltage Range	VDC	36-76	
Input Current(Typ)	A	16.5	16.4
Output Voltage Accuracy	%	±1	
Output Voltage Adjustment	VDC	7.2 - 13.8	16.8 - 32.2
Ripple & Noise (Max)	mV	200	280
Line Regulation (Max)	mV	24	56
Load Regulation (Max)	mV	24	56
Temperature Coefficient	-	0.02%/°C	
Overcurrent Protection	%	105 - 140%	
Overvoltage Protection	%	120 - 135%	
Parallel Operation		Yes	
Series Operation		Yes	
Signals & Control	-	Remote sense, remote On/Off, Parallel Pin, DC Good, 7-10V Auxiliary voltage	
Operating Temperature	-	-40°C to +100°C baseplate	
Humidity (operating)	-	20 - 95% RH Non condensing	
Humidity (storage)	-	10 - 95% RH Non condensing	
Cooling	-	Conduction (See Installation Manual for heatsink selection)	
Isolation Voltage	VDC	Input - Baseplate 1500V, Input - Output 1500V, Output-Baseplate 500V (for 1 min.)	
Shock	-	196.1m/s ²	
Vibration	-	Non Operating, 10-55Hz (sweep for 1 min.) Amplitude 0.825mm constant (Max 49 m/s ²) X,Y,Z 1 hour each	
Safety Agency Approvals	-	UL60950-1, CSAC22.2 No. 60950-1, EN60950, CE LVD	
Weight (Typ)	g	200	
Size (WxHxD)	mm (in)	61 x 12.7 x 116.8 (2.4 x 0.5 x 4.6) See outline drawing	
Warranty	yrs	2	

Notes: See Installation Manual for full details, test methods of parameters and application notes.



Derating Curve

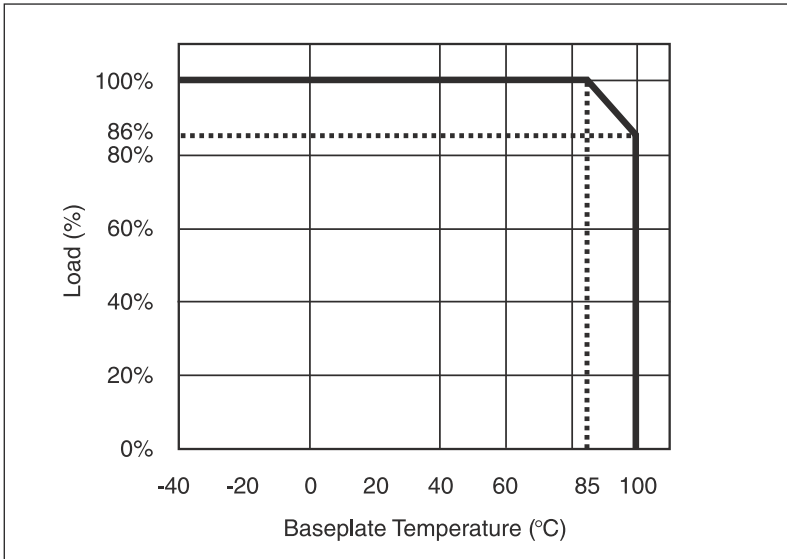

Part Number Scheme

Full Brick	Max Power Watts	Full Function	Nominal Input Voltage	Output Voltage	Option Suffix
PAF	700	F	48	12 or 28	Blank = M3 Tapped inserts T = 3.3mm Non-threaded through hole

Connection Example

Note

- 1 Use external fuse of fast blow type, for each unit
- 2 Put input capacitor, C1 and C2, greater than 220uF for each. If the impedance of input line is high, C1 and C2 capacitance must be greater than above.
- 3 Put output capacitor, C3 (12v: more than 470uF, 28V: greater than 220uF). If the ambient temperature is less than -20C, use 4 pieces of the recommended capacitor above.
- 4 Refer to instruction manual for further details.

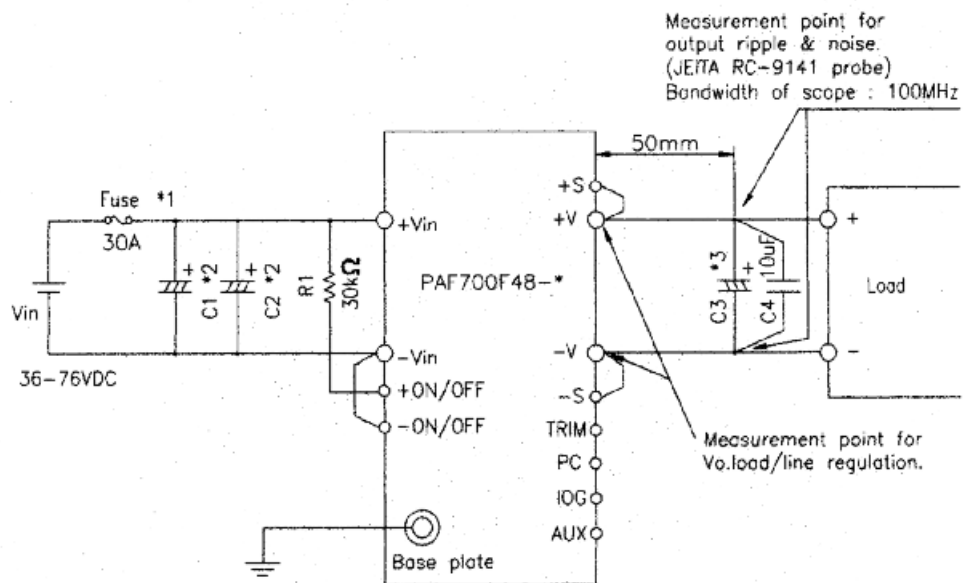



Outline Drawing PAF700F

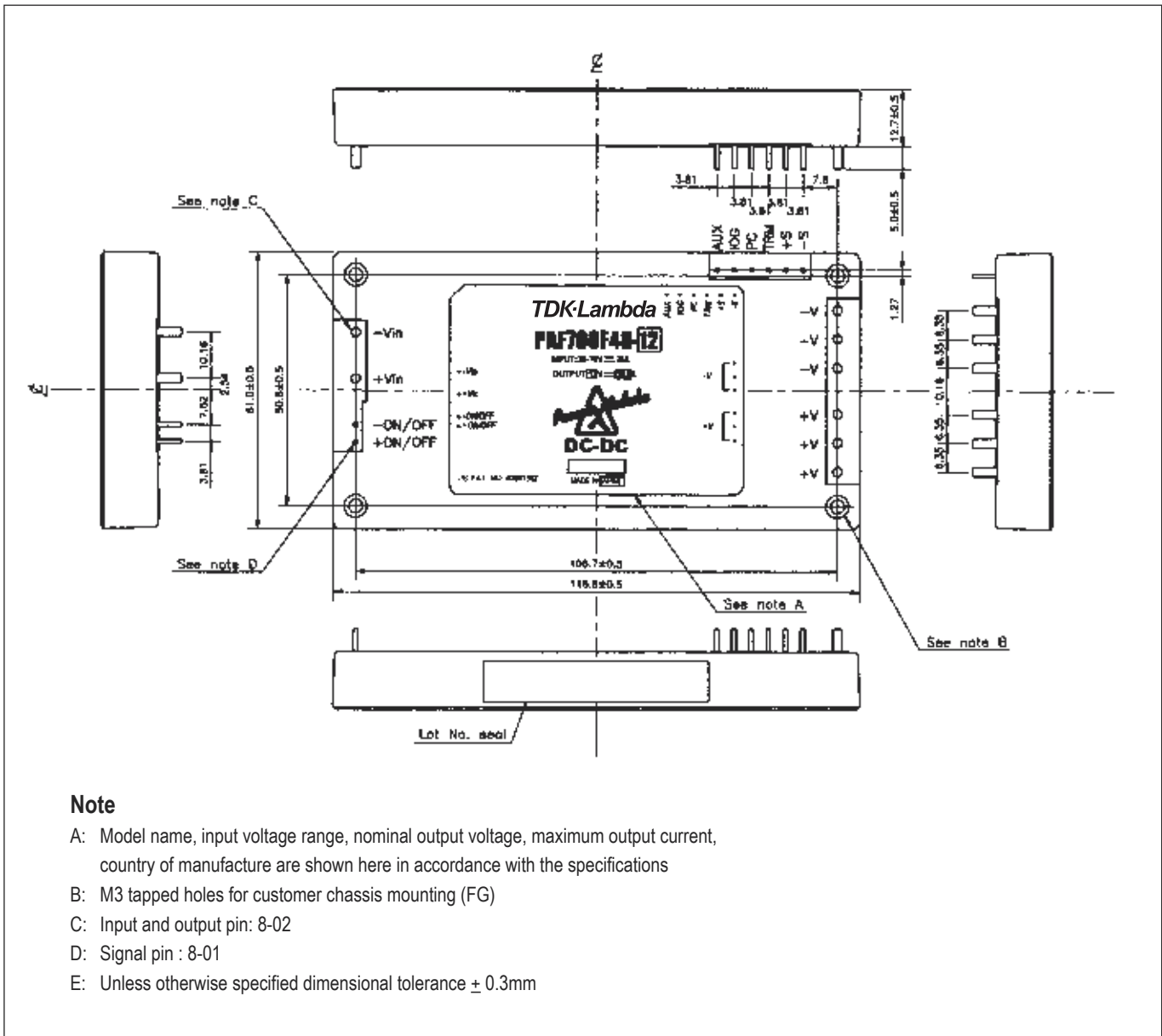

- A: Model name, input voltage range, nominal output voltage, maximum output current, country of manufacture are shown here in accordance with the specifications
- B: M3 tapped holes for customer chassis mounting (FG)
- C: Input and output pin: 8-02
- D: Signal pin : 8-01
- E: Unless otherwise specified dimensional tolerance $\pm 0.3\text{mm}$

Pinout	
Pin Description	Function
-Vin	Negative Input Terminal
+Vin	Positive Input Terminal
- ON/OFF	Remote On/Off Negative Terminal
+ON/OFF	Remote On/Off Positive Terminal
+V	Positive Output Terminal
-V	Negative Output Terminal
AUX	7-10V Aux Voltage
IOG	DC Good
PC	Parallel Control Connection
TRIM	Output Adjustment Trim Pin
+S	Positive Remote Sense
-S	Negative Remote Sense



- High Density
- Wide Range Input
- Output adjustment Capability
- Remote On/Off
- Fixed Switching Frequency
- International Safety Approvals

Key Market Segments & Applications

- Telecom
- Custom Power Supplies
- Point of Load

PH-S Series

Simple Function 50W to 600W
DC-DC Converters

PH-S Features and Benefits

Features

- High density
- Low component count
- Fixed operating frequency
- Variety of input voltages

Benefits

- Smaller package size
- High reliability Demonstrated 5 million hours MTBF
- Easier system filtering
- Systems can operate from different input voltages

Specifications

		3.3V	5V	12V	15V	24V	28V	48V
ITEMS								
Input range	VDC	24V nom: 18-36, 48V nom: 36-76V, 110V nom: 82-185V, 280V nom: 200-400V						
Output Voltage Adj. Range 300-600W	VDC	2.97-3.96	4.5-6	10.8-13.2	13.5-16.5	21.6-26.4	25.2-30.8	43.2-57.8
Output Voltage Adj. Range	VDC	2.97-3.63	4.5-5.5					43.2-52.8
Line Regulation	-	0.4% or 20mV (whichever is greater) over entire input range with constant load						
Load Regulation	-	0.8% or 40mV (whichever is greater) from no load to full load with constant input line						
Ripple and Noise	mV	100		150		240	280	480
Series Operation	-	Possible - Refer to installation manual						
Over Voltage Protection (2)	%	150 - 180		125 - 145				
Over Current Protection	%	Approximately 105 - 150, automatic recovery						
Remote On/Off	-	Short = ON, Open = OFF						
Remote Sensing	-	PH100S, PH150S, PH300S, PH600S models						
Parallel operation	-	PH300S & PH600S only: Requires external circuitry						
Inverter Good signal	-	PH300S & PH600S only: Signal available for status of inverter						
Thermal Protection	-	Internal sensing, self resetting						
Cooling	-	Conduction or forced air. See application notes for cooling and heatsink selection						
Operating Temperature Range	°C	Baseplate temperature -20°C to +85°C (+100°C on PH300 & PH600)						
	°C	-40°C start up versions available (1)						
Storage Temperature	°C	-40°C to +85°C (+100°C on PH300 & PH600)						
Temperature Coefficient	-	0.02%/°C						
Isolation	-	Input to output: 3000VAC, Input to Baseplate: 2500VAC						
Isolation Resistance	Ω	Output to Baseplate 100mΩ at 500VDC and 70%RH						
Safety Agency Approval	-	UL60950-1, CSA22.2 No.60950-1, EN60950 and CE Mark.						
Warranty	yrs	2						

Note: See Installation Manual for full details, test methods of parameters and application notes

(1) Please consult sales

(2) 50W: 165 - 240%, 300W - 600W: 140 - 190%



Model Selector						
Nominal Output Voltage (V)	Output Current (A)	Output Power (W)	24V input	48V input	110V input	280V input
3.3	10.0	33.0	PH50S24-3.3	PH50S48-3.3	-	PH50S280-3.3
3.3	15.0	49.5	-	PH75S48-3.3	-	PH75S280-3.3
3.3	20.0	66.0	-	PH100S48-3.3	-	PH100S280-3.3
3.3	30.0	99.0	-	PH150S48-3.3	-	PH150S280-3.3
3.3	50.0	165.0	-	-	-	PH300S280-3.3
3.3	100.0	330.0	-	-	-	PH600S280-3.3
5.0	10.0	50.0	PH50S24-5	PH50S48-5	PH50S110-5	PH50S280-5
5.0	15.0	75.0	-	PH75S48-5	PH75S110-5	PH75S280-5
5.0	20.0	100.0	-	PH100S48-5	-	PH100S280-5
5.0	30.0	150.0	-	PH150S48-5	PH150S110-5	PH150S280-5
5.0	50.0	250.0	-	-	-	PH300S280-5
5.0	100.0	500.0	-	-	-	PH600S280-5
12.0	4.2	50.0	PH50S24-12	PH50S48-12	PH50S110-12	PH50S280-12
12.0	6.3	75.0	-	PH75S48-12	PH75S110-12	PH75S280-12
12.0	8.4	100.0	-	PH100S48-12	-	PH100S280-12
12.0	12.5	150.0	-	PH150S48-12	PH150S110-12	PH150S280-12
12.0	25.0	300.0	-	-	-	PH300S280-12
12.0	50.0	600.0	-	-	-	PH600S280-12
15.0	3.4	50.0	PH50S24-15	PH50S48-15	PH50S110-15	PH50S280-15
15.0	5.0	75.0	-	PH75S48-15	PH75S110-15	PH75S280-15
15.0	6.7	100.0	-	PH100S48-15	-	PH100S280-15
15.0	10.0	150.0	-	PH150S48-15	PH150S110-15	PH150S280-15
15.0	20.0	300.0	-	-	-	PH300S280-15
15.0	40.0	600.0	-	-	-	PH600S280-15
24.0	2.1	50.0	PH50S24-24	PH50S48-24	PH50S110-24	PH50S280-24
24.0	3.2	75.0	-	PH75S48-24	PH75S110-24	PH75S280-24
24.0	4.2	100.0	-	PH100S48-24	-	PH100S280-24
24.0	6.3	150.0	-	PH150S48-24	PH150S110-24	PH150S280-24
24.0	12.5	300.0	-	-	-	PH300S280-24
24.0	25.0	600.0	-	-	-	PH600S280-24
28.0	1.8	50.0	PH50S24-28	PH50S48-28	PH50S110-28	PH50S280-28
28.0	2.7	75.0	-	PH75S48-28	PH75S110-28	PH75S280-28
28.0	3.6	100.0	-	PH100S48-28	-	PH100S280-28
28.0	5.4	150.0	-	PH150S48-28	PH150S110-28	PH150S280-28
28.0	10.8	302.0	-	-	-	PH300S280-28
28.0	21.5	602.0	-	-	-	PH600S280-28
48.0	6.3	302.0	-	-	-	PH300S280-48
48.0	12.5	600.0	-	-	-	PH600S280-48

PIN Assignments	
Pin Description	Function
-Vin	Negative Input Terminal
+Vin	Positive Input Terminal
+S	Positive Remote sense
-S	Negative Remote sense
+V	Positive Output Terminal
-V	Negative Output Terminal
IOG	Inverter Good Signal
TRIM	Output adjustment trim pin
CNT	On/Off Control Terminal
CS	Current Monitor Signal

For full data and drawings please visit www.emea.tdk-lambda.com/ph



- High Density
- Wide Range Input
- Wide output adjustment capability
- Remote On/Off
- Fixed Switching Frequency
- International Safety Approvals
- Parallel Operation

Key Market Segments & Applications

- Telecom
- Custom Power Supplies
- N+1 redundant systems
- Scalable systems
- Point of Load

PH-F Series

Full Function 50W to 300W
DC-DC Converters

PH-F Features and Benefits

Features

- Low component count
- Wide output adjustment
- Signals to support N+1 redundancy
- Variety of input voltages

Benefits

- High reliability demonstrated 5 million hours MTBF
- Avoids the need for custom modules
- Ease of use in redundant configurations
- Systems can operate from different input voltages

Specifications

		2V	3.3V	5V	12V	15V	24V	28V
ITEMS								
Input range	VDC	24V nom: 18-36, 48V nom: 36-76V, 110V nom: 82-185V, 280V nom: 200-400V						
Output Voltage Adj. Range	VDC	1.6~2.4	2.64~3.96	2~6	4.8~14.4	6~18	9.6~28.8	11.2~33.6
Line Regulation	-	0.4% or 20mV (whichever is greater) over entire input range with constant load						
Load Regulation	-	0.8% or 40mV (whichever is greater) from no load to full load with constant input line						
Ripple and Noise	mV	100		150		240		280
Series Operation	-	Possible - Refer to installation manual						
Over Voltage Protection	-	150 - 180%		125 - 145%				
Overload Protection	-	Approximately 105 - 140%, automatic recovery						
Remote On/Off	-	Short = ON, Open = OFF						
Remote Sensing	-	Yes						
Parallel operation	-	Using current share pin (PC). Will share within 5%, see app. notes for connection details						
Inverter Good signal	-	Signal available for status of inverter						
Auxiliary Bias Supply	-	7-10V 10mA auxiliary voltage to supply power to interface circuits (AUX pin)						
Thermal Protection	-	Internal sensing, self resetting						
Cooling	-	Conduction or forced air. See application notes for cooling and heatsink selection						
Operating Temperature Range	°C	Baseplate temperature -20°C to +85°C (-40°C start up versions available (2))						
Storage Temperature	°C	-40°C to +85°C						
Temperature Coefficient	-	0.02%/°C						
Isolation	-	Input to output: 3000VAC, Input to Baseplate: 2500VAC(1)						
Isolation Resistance	Ω	Output to Baseplate -100mΩ at 500VDC and 70%RH						
Safety Agency Approval	-	UL60950-1, CSA22.2 No.60950-1, EN60950-1 and CE Mark.						
Warranty	yrs	2						

Note: See Installation Manual for full details, test methods of parameters and application notes
 (1) 24V input models input to output: 2kVAC; input to baseplate: 2kVAC
 (2) Please consult sales



Model Selector						
Nominal Output Voltage (V)	Output Current (A)	Output Power (W)	24V input	48V input	110V input	280V input
2.0	15.0	30	-	PH75F48-2	PH75F110-2	PH75F280-2
2.0	20.0	40	PH100F24-2	-	-	-
2.0	30.0	60	-	PH150F48-2	PH150F110-2	PH150F280-2
2.0	60.0	120	-	PH300F48-2	PH300F110-2	PH300F280-2
3.3	15.0	45	-	PH75F48-3	PH75F110-3	PH75F280-3
3.3	20.0	60	PH100F24-3	-	-	-
3.3	30.0	90	-	PH150F48-3	PH150F110-3	PH150F280-3
3.3	60.0	180	-	PH300F48-3	PH300F110-3	PH300F280-3
5.0	15.0	75	-	PH75F48-5	PH75F110-5	PH75F280-5
5.0	20.0	100	PH100F24-5	-	-	-
5.0	30.0	150	-	PH150F48-5	PH150F110-5	PH150F280-5
5.0	60.0	300	-	PH300F48-5	PH300F110-5	PH300F280-5
12.0	6.3	75	-	PH75F48-12	PH75F110-12	PH75F280-12
12.0	8.4	100	PH100F24-12	-	-	-
12.0	12.5	150	-	PH150F48-12	PH150F110-12	PH150F280-12
12.0	20.0	240	PH300F24-12	-	-	-
12.0	25.0	300	-	PH300F48-12	PH300F110-12	PH300F280-12
15.0	5.0	75	-	PH75F48-15	PH75F110-15	PH75F280-15
15.0	6.7	100	PH100F24-15	-	-	-
15.0	10.0	150	-	PH150F48-15	PH150F110-15	PH150F280-15
15.0	20.0	300	-	PH300F48-15	PH300F110-15	PH300F280-15
24.0	3.2	75	-	PH75F48-24	PH75F110-24	PH75F280-24
24.0	4.2	100	PH100F24-24	-	-	-
24.0	6.3	150	-	PH150F48-24	PH150F110-24	PH150F280-24
24.0	12.6	300	-	PH300F48-24	PH300F110-24	PH300F280-24
28.0	2.7	50	-	PH75F48-28	PH75F110-28	PH75F280-28
28.0	3.6	100	PH100F24-28	-	-	-
28.0	5.4	150	-	PH150F48-28	PH150F110-28	PH150F280-28
28.0	10.8	300	PH300F24-28	PH300F48-28	PH300F110-28	PH300F280-28

PIN Assignments

Pin Description	Function
-Vin	Negative Input Terminal
+Vin	Positive Input Terminal
+S	Positive Remote sense
-S	Negative Remote sense
+V	Positive Output Terminal
-V	Negative Output Terminal
AUX	Bias voltage output (secondary ref)
IOG	DC Good
TRIM	Output adjustment trim pin
CNT	On / Off Control terminal
SG	Signal (CNT RTN)
PC	Parallel control connection

Options

Suffix	Description
-	M3 Tapped inserts for mounting
/T	M3 clearance inserts for mounting
/P	Positive logic remote On/Off

For full data and drawings please visit
www.emea.tdk-lambda.com/ph



Isolated PCB Mount and Surface Mount DC-DC Converters

A comprehensive range of standalone pcb mount dc-dc converters offering output power from 0.7W to 60W, single, dual and triple outputs and a wide choice of input voltages including 4:1 input range options.
Suitable for any OEM equipment.



CC-E Series 0.72 - 25W Single & Dual Output

Page No.

217



CC-P-E Series 14.9 - 30W Single Output

220



PXA Series 11.6 - 15W Single & Dual Output

223



PXB Series 13.2 - 15W Single & Dual Output

226



PXC Series 3.3 - 6W Single & Dual Output

229



PXD Series 6.6 - 20W Single & Dual Output

232



PXD30W 30W Single & Dual Output

235



PXE Series 19.8 - 30W Single & Dual Output

238



PXF Series 24 - 60W Single, Dual & Triple Output

241



- Compact Footprint/Low Profile
- Through Hole or SMT Versions
- 5V, 12V, 24V & 48V Inputs
- 3.3 to 30V¹ Single, ± 12 to 15V Dual Outputs
- Output Voltage Adjustment
- Input - Output Isolation
- RoHS Compliant
- 5 Year Warranty

CC-E Series

Ultra Compact, 1.5W to 25W Single & Dual DC-DC Converters

Key Market Segments & Applications

- Telecommunications
- Instrumentation
- Datacom

CC-E Features and Benefits

Features

- Compact
- Self Contained
- Multiple Input Voltage configurations
- Open Frame (no potting)

Benefits

- Less PCB Area Used
- Requires No External Components
- Easier System Configuration
- Lighter in Weight, Suitable for Surface Mount (R Version)

Specifications

		3.3V	5V	12/15V	$\pm 12/15$ (24/30) ¹
Nominal Output Voltage	V				
DC Input	V	5V: 4.5-9.0V, 12V: 9-18V, 24V: 18-36V, 48V: 36-76V			
Efficiency	%	71 to 90% model dependant			
Output Voltage Tolerance	%	1.5-10W: $\pm 3\%$, 15-25W: $\pm 5\%$			
Output Adjustment (via trim pin)	V	3.15-3.6V	4.75-6.0V	11.4-15V	22.8 - 30V
Line Regulation	mV	20 (40 CC15; 30 CC25)		40	80
Load Regulation	mV	40 (120 CC15; 200 CC25)		100	600 ²
Temperature Coefficient	%	$\pm 0.02\%/^{\circ}\text{C}$			
Preload	-	No preload required			
Output Ripple (typ./max.BW 50MHz)	mV	40/120		30/120	
Overcurrent Protection	-	Output current limiting with automatic recovery, shutdown CC15, 25 type			
Overvoltage Protection	-	No			
Remote On/ Off	-	CC1R5, 3, 6, & 10: RC terminal open, output is OFF; RC terminal to -Vin (0-0.4V), output is ON CC15 & CC25: RC terminal open, output is ON; RC terminal to +Vin, output is OFF			
Operating Temp.- Convection	$^{\circ}\text{C}$	-40 $^{\circ}\text{C}$ to +85 $^{\circ}\text{C}$, derates linearly to 40% load from +50 $^{\circ}\text{C}$ to +85 $^{\circ}\text{C}$			
Operating Temp.- Forced Air	$^{\circ}\text{C}$	-40 $^{\circ}\text{C}$ to +85 $^{\circ}\text{C}$ with 1m/s air full load			
Storage Temperature	$^{\circ}\text{C}$	-40 $^{\circ}\text{C}$ to +85 $^{\circ}\text{C}$			
Humidity (non Condensing)	-	95% RH max.(maximum wet-bulb temperature: +38 $^{\circ}\text{C}$)			
Isolation Voltage	-	500VAC 1 min. Input to output, input to case, output to case			
Isolation Resistance	Ω	Input to output, input to case, output to case: 50m Ω min. (500VDC)			
Shock	m/s ²	980m/s ² (100G) 6ms (6 directions, each 3 times)			
Vibration (non Operating)	-	10 to 55Hz (sweep for 15min) 1.52mm constant, 3 directions X, Y, Z each 2 hours			
Safety Agency Approvals	-	UL60950-1, CSA60950-1, EN60950-1			
Weight	g	CC1R5: 3.2, CC3: 4.5, CC6: 5.8, CC10:10.0, CC15: 12.5, CC25: 20.0			
Size (L x W x H) (Through Hole & SMD package)	mm	CC1R5: 16.51 x 16.61 x 8.51; CC3: 22.86 x 16.61 x 8.51; CC6: 22.86 x 21.11 x 8.51 CC10: 35.56 x 22.61 x 8.51 CC15: 38.10 x 32.11 x 7.49; CC25: 43.21 x 44.91 x 7.49 CC3: SIP type 27.69 x 9.19 x 17.91			
Warranty	yrs	5			

Notes:

1. For 24V/30V output - connect across +Vout & -Vout and leave "common out" pin not connected.
2. Based upon equal load current from both outputs. 3. For 15V output connect trim to -Vout.
4. See Installation Manual for full specifications, test methods of parameters and application notes.



Model Selector						
Output Voltage (V)	Output Current (A)	Output Power (W)	5V Input	12V Input	24V Input	48V Input
Single Outputs						
3.3	0.4	1.5	CC1R5-0503SF-E	CC1R5-1203SF-E	CC1R5-2403SF-E	CC1R5-4803SF-E
3.3	0.8	3	CC3-0503SF-E	CC3-1203SF-E	CC3-2403SF-E	CC3-4803SF-E
3.3	1.2	6	CC6-0503SF-E	CC6-1203SF-E	CC6-2403SF-E	CC6-4803SF-E
3.3	2.5	10	CC10-0503SF-E	CC10-1203SF-E	CC10-2403SF-E	CC10-4803SF-E
3.3	4.5	15	-	-	CC15-2403SF-E	-
3.3	7.5	25	-	-	CC25-2403SF-E	-
5	0.3	1.5	CC1R5-0505SF-E	CC1R5-1205SF-E	CC1R5-2405SF-E	CC1R5-4805SF-E
5	0.6	3	CC3-0505SF-E	CC3-1205SF-E	CC3-2405SF-E	CC3-4805SF-E
5	1.0	5	CC6-0505SF-E	-	-	-
5	1.2	6	-	CC6-1205SF-E	CC6-2405SF-E	CC6-4805SF-E
5	2.0	10	CC10-0505SF-E	CC10-1205SF-E	CC10-2405SF-E	CC10-4805SF-E
5	3.0	15	-	-	CC15-2405SF-E	-
5	5.0	25	-	-	CC25-2405SF-E	-
12(15)	0.125(0.1)	1.5	CC1R5-0512SF-E	CC1R5-1212SF-E	CC1R5-2412SF-E	CC1R5-4812SF-E
12(15)	0.25(0.2)	3	CC3-0512SF-E	CC3-1212SF-E	CC3-2412SF-E	CC3-4812SF-E
12(15)	0.5(0.4)	6	CC6-0512SF-E	CC6-1212SF-E	CC6-2412SF-E	CC6-4812SF-E
12(15)	0.8(0.64)	10	CC10-0512SF-E	-	-	-
12(15)	1.0(0.8)	10	-	CC10-1212SF-E	CC10-2412SF-E	CC10-4812SF-E
Dual Outputs						
±12 (15) ³	0.06(0.05)	1.5	CC1R5-0512DF-E	CC1R5-1212DF-E	CC1R5-2412DF-E	CC1R5-4812DF-E
±12 (15) ³	0.125(0.1)	3	CC3-0512DF-E	CC3-1212DF-E	CC3-2412DF-E	CC3-4812DF-E
±12 (15) ³	0.25(0.2)	6	CC6-0512DF-E	CC6-1212DF-E	CC6-2412DF-E	CC6-4812DF-E
±12 (15) ³	0.4(0.32)	10	CC10-0512DF-E	-	-	-
±12 (15) ³	0.45(0.36)	10	-	CC10-1212DF-E	CC10-2412DF-E	CC10-4812DF-E

Options	
Version	Description
F-E	Through hole mounting (DIP)
R-E	Surface mount (SMD)
S-E	Through hole mounting (SIP) (SIP option available for CC3 only)

Pinout (CC1R5, 3, 6, and 10)		
Pin	Single	Dual
1	+Vin	+Vin
2	RC	RC
3	-Vin	-Vin
4	NC	-Vout
5	-Vout	Common out
6	TRM	TRM
7	+Vout	+Vout

For CC15 and 25 see Installation Manual online



Pin Out Diagrams CC-E Series

CONNECTIONS
CC1R5-□□□□S□-E

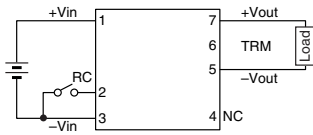

TERMINAL PIN CONFIGURATION

No.1	+Vin
No.2	RC
No.3	-Vin
No.4	NC
No.5	-Vout
No.6	TRM
No.7	+Vout

CC1R5-□□□□D□-E

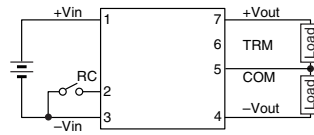

TERMINAL PIN CONFIGURATION

No.1	+Vin
No.2	RC
No.3	-Vin
No.4	-Vout
No.5	Common out
No.6	TRM
No.7	+Vout

CONNECTIONS
CC3-□□□□S□-E

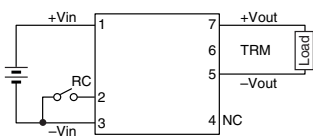

TERMINAL PIN CONFIGURATION

No.1	+Vin
No.2	RC
No.3	-Vin
No.4	NC
No.5	-Vout
No.6	TRM
No.7	+Vout

CC3-□□□□D□-E

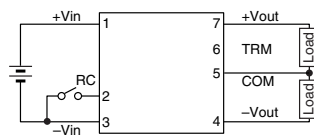

TERMINAL PIN CONFIGURATION

No.1	+Vin
No.2	RC
No.3	-Vin
No.4	-Vout
No.5	Common out
No.6	TRM
No.7	+Vout

CONNECTIONS
CC6-□□□□S□-E

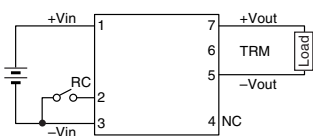

TERMINAL PIN CONFIGURATION

No.1	+Vin
No.2	RC
No.3	-Vin
No.4	NC
No.5	-Vout
No.6	TRM
No.7	+Vout

CC6-□□□□D□-E

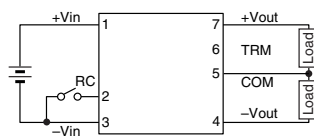

TERMINAL PIN CONFIGURATION

No.1	+Vin
No.2	RC
No.3	-Vin
No.4	-Vout
No.5	Common out
No.6	TRM
No.7	+Vout

CONNECTIONS
CC10-□□□□S□-E

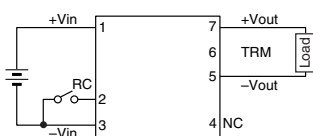

TERMINAL PIN CONFIGURATION

No.1	+Vin
No.2	RC
No.3	-Vin
No.4	NC
No.5	-Vout
No.6	TRM
No.7	+Vout

CC10-□□□□D□-E

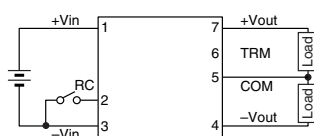

TERMINAL PIN CONFIGURATION

No.1	+Vin
No.2	RC
No.3	-Vin
No.4	-Vout
No.5	Common out
No.6	TRM
No.7	+Vout

CONNECTION CC15-xxxxSF-E (DIP TYPE)

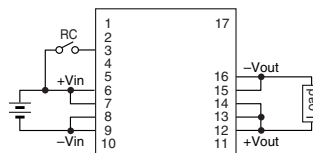

TERMINAL PIN CONFIGURATION

No.1	NC	No.10	NC
No.2	NC	No.11	NC
No.3	NC	No.12	+Vout
No.4	RC	No.13	+Vout
No.5	NC	No.14	+Vout
No.6	+Vin	No.15	-Vout
No.7	+Vin	No.16	-Vout
No.8	-Vin	No.17	NC
No.9	-Vin		

CONNECTION CC25-xxxxSF-E (DIP TYPE)

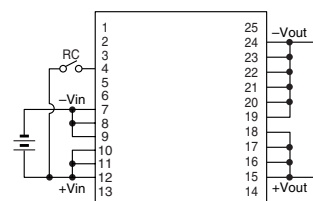

TERMINAL PIN CONFIGURATION

No.1	NC	No.10	+Vin	No.19	-Vout
No.2	NC	No.11	+Vin	No.20	-Vout
No.3	NC	No.12	+Vin	No.21	-Vout
No.4	RC	No.13	NC	No.22	-Vout
No.5	NC	No.14	NC	No.23	-Vout
No.6	NC	No.15	+Vout	No.24	-Vout
No.7	-Vin	No.16	+Vout	No.25	NC
No.8	-Vin	No.17	+Vout		
No.9	-Vin	No.18	+Vout		



- Compact Footprint / Low Profile
- 24V & 48V Inputs
- 3.3V to 15V Outputs
- Input - Output Isolation
- Through Hole or SMT Versions
- DC OK signal
- Sequencing pin
- 5 Year Warranty

CC-P-E Series

Ultra Compact, 15W to 30W
DC-DC Converters

Key Market Segments & Applications

- Process Control
- Instrumentation
- Datacom & Telecom

CC-E Features and Benefits

Features

- Compact
- Five Sided Shielding (cased version)
- Parallel Operation

Benefits

- Less PCB Area Used
- Lower radiated EMI
- Provides additional power / redundancy

Specifications

Specifications		3.3V	5V	12V	15V
Nominal Output Voltage	V	3.3V	5V	12V	15V
DC Input	VDC	24V Nominal: 18-36V, 48V Nominal: 36-76V			
Efficiency	%	89 to 92% model dependant			
Initial set accuracy	%	±1%			
Total Regulation limits	%	+5%, -3%			
Output Adjustment	-	None			
Temperature Coefficient	%/°C	<0.02%/°C			
Preload	A	None			
Output Ripple	mV	50mV		150mV	
Overcurrent Protection	-	> 103% of nominal rating			
Overvoltage protection	-	Operates at 115 - 145% of nominal voltage			
Remote On/Off (RC)	-	Logic high (pull high to shutdown), referenced to -Vin			
Alarm (ALM)	-	Low On Fail, referenced to -Vin. 20 units maximum			
Sequencing (PO)	-	Connecting PO terminals on multiple power supplies ensures all simulataneously start up (20 units maximum)			
Cooling	-	Convection			
Operating Temp. Range	°C	-40°C to +85°C			
Storage Temperature	°C	-40°C to +85°C			
Humidity (Non condensing)	%RH	5 - 95%RH			
Isolation Voltage (Cased version)	VDC	1000VDC 1 min. Input-Output, Input-Chassis, Output-Chassis			
Isolation Voltage (Uncased version)	VDC	1500VDC 1 min. Input-Output			
Isolation Resistance	Ω	>50mΩ at 25°C and 70%RH, 500 VDC Input-Output, Input-Case, Output-Case			
Shock (Non operating)	-	980m/s ² (100G), 6ms, 6 directions, 3 times			
Vibration (non operating)	-	10-55-10 Hz (sweep for 15 min.) 1.52mm amplitude, 2 hour X, Y, Z			
Safety Certifications	-	UL60950-1, CSA C22.2 No.60950-1 (c-UL), EN60950-1			
Weight	g	With case: CC15 15g, CC30 20g. Without case: CC15 10g, CC30 15g			
Size (LxWxH) (Thru hole ver., w/ case)	mm	CC15: 38.4 x 6.8 x 29.6mm, CC30: 38.4 x 8.3 x 33.5mm			
Warranty	yrs	5			

Notes:

See Installation Manual for full specifications, test methods of parameters and application notes.



Model Selector

Output Voltage (V)	Output Current (A)	Max O/P Power (W)	24V Input	48V Input
3.3	4.5	15	CC15-2403SFP-E	CC15-4803SFP-E
3.3	9	30	CC30-2403SFP-E	CC30-4803SFP-E
5	3	15	CC15-2405SFP-E	CC15-4805SFP-E
5	6	30	CC30-2405SFP-E	CC30-4805SFP-E
12	1.25	15	CC15-2412SFP-E	CC15-4812SFP-E
12	2.5	30	CC30-2412SFP-E	CC30-4812SFP-E
15	1	15	CC15-2415SFP-E	CC15-4815SFP-E
15	2	30	CC30-2415SFP-E	CC30-4815SFP-E

Options

Version	PIN	Case
CCxx-yyySFP-E*	Through hole	Yes
CCxx-yyySFH-E	Through hole	No
CCxx-yyySRP-E	SMT	Yes
CCxx-yyySRH-E	SMT	No

Where xx is output power & yyy is input and output voltage combination. * denotes preferred model

Pinout SFP-E Models

Pin	Pin Name	Function
1	Stopper	Stopper
2	+Vout	+DC output
3	+Vout	+DC output
4	+Vout	+DC output
5	-Vout	-DC output
6	-Vout	-DC output
7	Stopper	Stopper
8	NC	Not connected
9	ALM	Alarm
10	RC	Remote control
11	PO	Start in / out
12	Stopper	Stopper
13	+Vin	+DC input
14	+Vin	+DC input
15	-Vin	-DC input
16	-Vin	-DC input
17	NC	Not connected

Pinout SRP-E Models

Pin	Pin Name	Function
1	NC	Not connected
2	+Vout	+DC output
3	+Vout	+DC output
4	+Vout	+DC output
5	-Vout	-DC output
6	-Vout	-DC output
7	NC	Not connected
8	NC	Not connected
9	ALM	Alarm
10	RC	Remote control
11	PO	Start in / out
12	NC	Not connected
13	+Vin	+DC input
14	+Vin	+DC input
15	-Vin	-DC input
16	-Vin	-DC input
17	NC	Not connected



Outline Drawing CC15-xxxxSFP-E Series

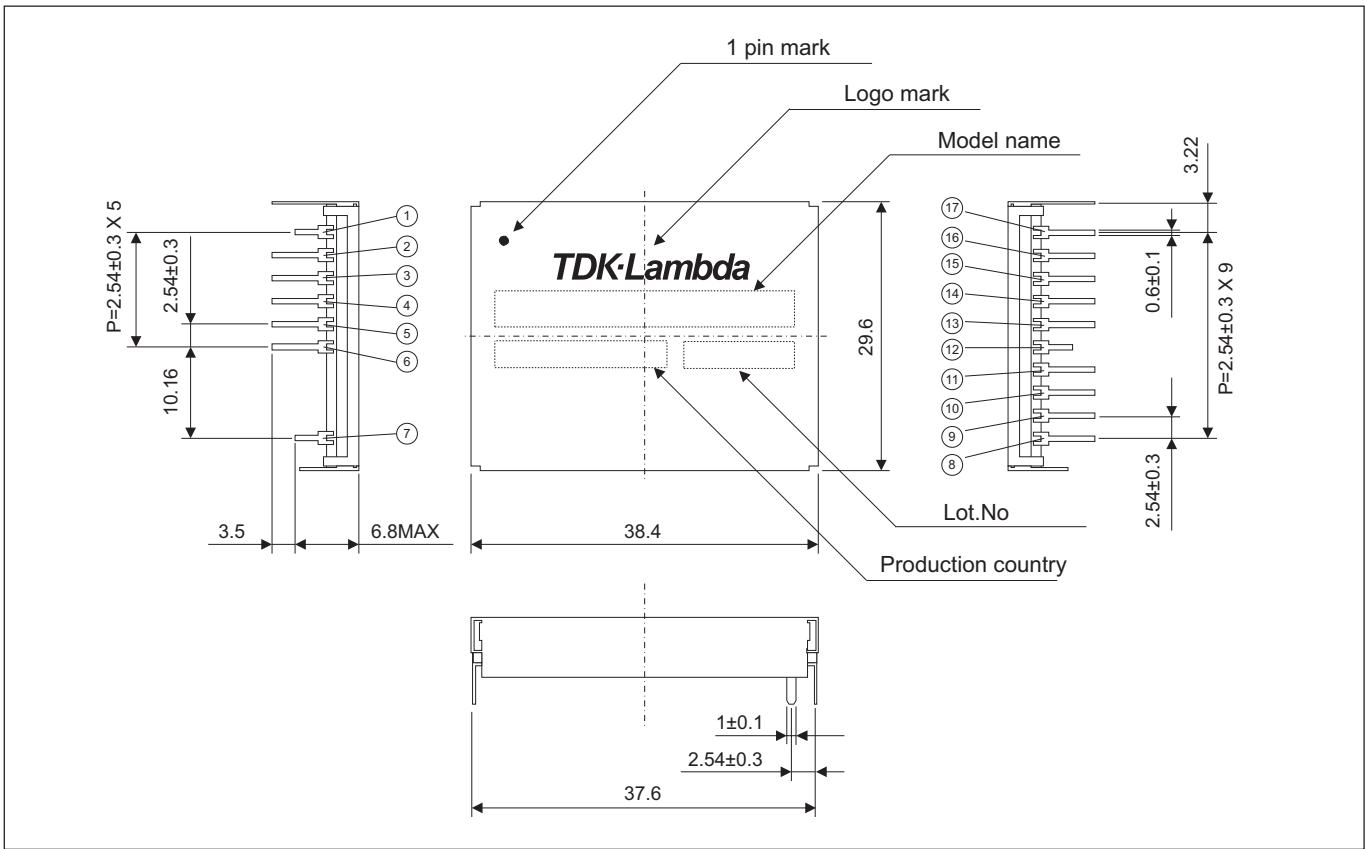

Outline Drawing CC30-xxxxSRP-E Series

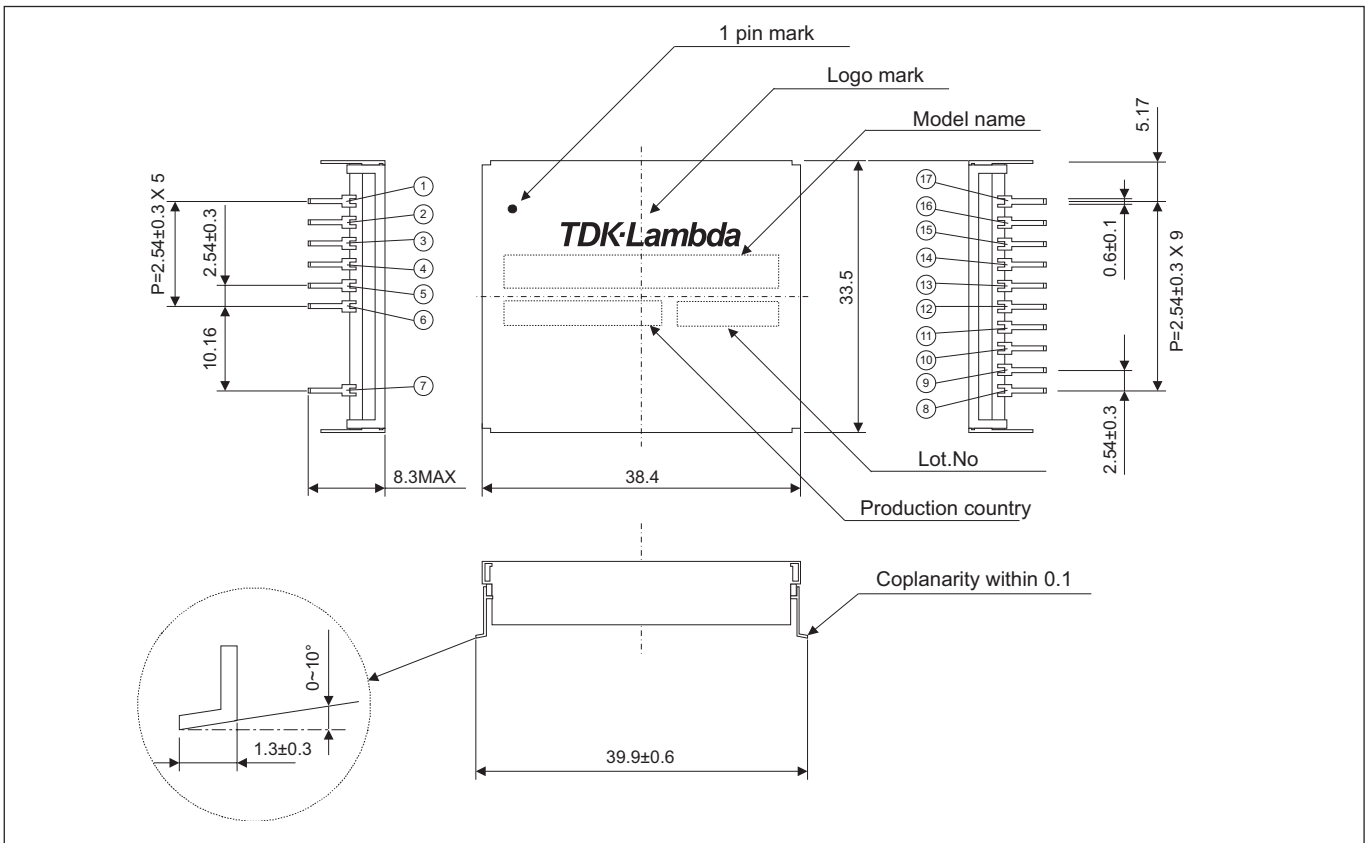

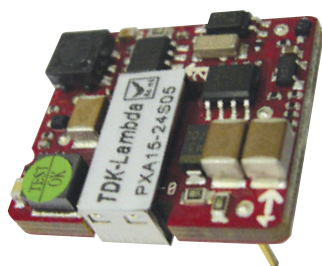

PXA15 Series

Single Output 15W
DC-DC Converters

- Industry Standard 1" x 1" Footprint
- 9-36V or 18-75VDC Input
- Pin & Surface Mount Models
- Efficiency up to 88%
- Fixed switching Frequency

Key Market Segments & Applications

- Telecom/Datcom
- Process Control
- Wireless Network
- Measurement & Test

PXA15 Features and Benefits

Features

- UL, C-UL, VDE CE
- 2:1 and 4:1 Range Input
- Surface mount or Through hole

Benefits

- Easier system approvals
- Less parts to inventory
- Reduced radiated noise

Specifications	Single Output		
Max Output Power	15W		
Voltage Accuracy	+/-1%		
Voltage Adjustment (1)	+/-10%		
Minimum Load	None		
Line Regulation	+/-0.2%		
Load Regulation	+/-0.2%		
Ripple and Noise	See table		
Start up time	Nominal VIN and constant Resistive load	Power Up 30mS Remote ON/OFF 30mS	
Start up voltage 2:1 Input 24V/48V	17VDC/33VDC		
Start up voltage 4:1 Input 24V/48V	9VDC/18VDC		
Shut down voltage 2:1 Input 24V/48V	14.5VDC/30.5VDC		
Shut down voltage 4:1 24V/48V	8VDC/16VDC		
Remote on/off	Positive Logic: ON: Open or 3-15V, OFF Short or <1.2V Negative Logic: ON: Short or <1.2V, OFF: Open or 3-15V		
Efficiency	See table		
Temperature Coefficient	<+/-0.02%/°C		
Operating Temperature	-40°C to +85°C, derating necessary above 60°C		
Storage Temperature	-55°C to +125°C		
Thermal Shock	MIL-STD-810F		
Relative Humidity (non condensing)	5 to 95%		
Transient Response (25% step load change)	PXA < 200µS, PXA-W < 300µS recovery		
Overvoltage Protection (Zener clamp)	120 - 130%		
Overcurrent and Short Circuit Protection	Typically at 150%, hiccup with self recovery		
Input Surge Voltage (Maximum for 100ms)	24V input: 50V, 48V input: 100V		
Reflected input ripple (peak to peak)	30mA Typ		
Isolation Voltage (Basic Insulation)	2250VDC minimum		
Isolation Resistance	10 ⁹ Ω minimum		
Isolation Capacitance (max)	2:1 Input, 1000pF/ 4:1 Input, 1500pF		
Typical Switching Frequency (Fixed)	2:1 Input	3.3V, 5V 12V, 15V	270kHz 470kHz
	4:1 Input	3.3V, 5V 12V, 15V	350kHz 400kHz
MTBF (BELLCORE TR-NWT-000332)	2:1 Input	2,200,000 hours	
	4:1 Input	1,322,000 hours	
Conducted and Radiated Emissions (2)	MIL-STD-810F EN55022 Level A		
Immunity (3)	EN61000-4-3, -4, -5, -6 Pref Criteria A		
Safety Agency Certifications	IEC60950-1, UL60950-1, EN60950-1, CE Mark		
Size mm (L x W x H)	27.9 x 23.9 x 8.5		
Weight (g)	10.5		
Warranty (yrs)	2		



Model Selector

Model	Output Voltage V	Output Current A	Output Power W	Input Voltage V	Nominal Input Current mA	Efficiency %	Ripple and Noise mVp-p	Max Load Capacitance uF
4:1 INPUT Single Outputs								
PXA15-24WS3P3	3.3V	4.0A	13.2W	9 - 36VDC	680mA	85%	100mVp-p	1000uF
PXA15-48WS3P3	3.3V	4.0A	13.2W	18 - 75VDC	340mA	85%	100mVp-p	1000uF
PXA15-24WS05	5V	3.0A	15W	9 - 36VDC	754mA	87%	100mVp-p	1000uF
PXA15-48WS05	5V	3.0A	15W	18 - 75VDC	377mA	87%	100mVp-p	1000uF
PXA15-24WS12	12V	1.25A	15W	9 - 36VDC	793mA	86%	100mVp-p	330uF
PXA15-48WS12	12V	1.25A	15W	18 - 75VDC	397mA	86%	100mVp-p	330uF
PXA15-24WS15	15V	1.0A	15W	9 - 36VDC	763mA	86%	100mVp-p	220uF
PXA15-48WS15	15V	1.0A	15W	18 - 75VDC	382mA	86%	100mVp-p	220uF
2:1 INPUT								
PXA15-24S3P3	3.3V	3.5A	10.5W	18-36VDC	587mA	86%	75mVp-p	1000uF
PXA15-48S3P3	3.3V	3.5A	10.5W	36-75VDC	297mA	85%	75mVp-p	1000uF
PXA15-24S05	5V	3.0A	15W	18-36VDC	753mA	87%	75mVp-p	1000uF
PXA15-48S05	5V	3.0A	15W	36-75VDC	377mA	87%	75mVp-p	1000uF
PXA15-24S12	12V	1.25A	15W	18-36VDC	753mA	87%	100mVp-p	330uF
PXA15-48S12	12V	1.25A	15W	36-75VDC	377mA	87%	100mVp-p	330uF
PXA15-24S15	15V	1.0A	15W	18-36VDC	744mA	88%	100mVp-p	220uF
PXA15-48S15	15V	1.0A	15W	36-75VDC	372mA	88%	100mVp-p	220uF

Specification Notes:

- (1) Output can be trimmed using an external resistor
- (2) To meet EN55022 Class B external filter components are required. See additional application note.
- (3) To meet EN61000-4-4, EN610004-5 an external filter capacitor is required. See additional application note.

Remote On/Off Options

Suffix	Description
P	Positive Logic
N	Negative Logic
S	Surface Mount
T	Trim

-NST or -NT as standard
Delete suffix if not required

Pinout - Single Output

Pin#	Function
1	+ Input
2	- Input
3	Remote On/Off
4	+ Output
5	Trim
6	- Output



Outline Drawing PXA15 Series

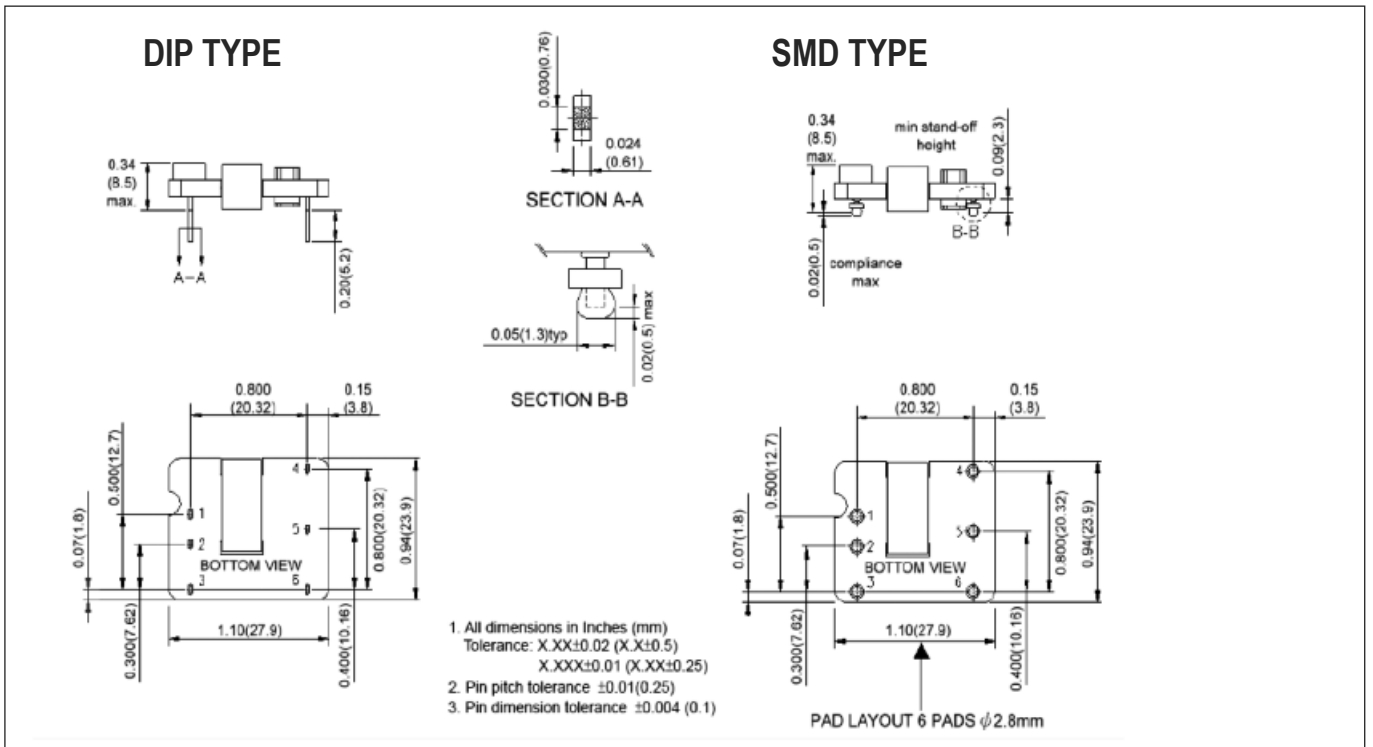

Derating Curve PXA15 Series

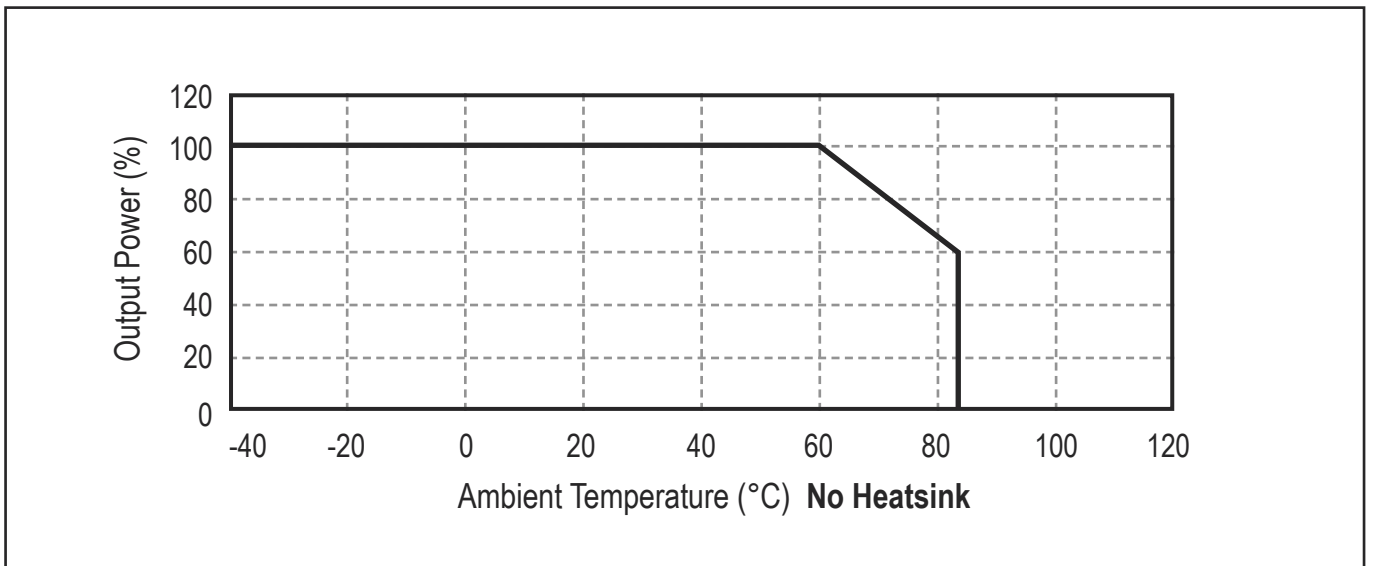



PXB15 Series

Single and Dual output 15W
DC-DC converters

- Industry Standard 1" x 1" Footprint
- 9-36V or 18-75VDC Input
- Six Sided Shield
- Standard pin out compatible with 2" x 1" products
- Efficiency up to 89%
- Fixed switching frequency

Key Market Segments & Applications

- Telecom/Datacom
- Process Control
- Wireless Network
- Measurement & Test

PXB15 Features and Benefits

Features

- UL, C-UL, VDE CE
- 2:1 and 4:1 Range Input
- Low Profile

Benefits

- Easier system approvals
- Less parts to inventory
- Reduced radiated noise

Specifications	Single Output	Dual Output
Max Output Power	15W	
Voltage Accuracy	+/-1%	
Voltage Adjustment (1)	+/-10%	
Minimum Load	None	
Line Regulation Single/Dual output	+/-0.2%	+/-0.5%
Load Regulation Single/Dual output	+/-0.2%	+/-1.0%
Cross regulation	+/-5%	
Ripple and Noise	See table	
Start up time	Nominal VIN and constant Resistive load	Power Up 30mS Remote ON/OFF 30mS
Start up voltage 2:1 Input 12V/24V/48V	9VDC/17VDC/33VDC	
Start up voltage 4:1 Input 24V/48V	9VDC/18VDC	
Shut down voltage 2:1 Input 12V/24V/48V	8VDC/14.5VDC/30.5VDC	
Shut down voltage 4:1 24V/48V	8VDC/16VDC	
Remote on/off	Positive Logic: ON: Open or 3-15V, OFF Short or <1.2V Negative Logic: ON: Short or <1.2V, OFF: Open or 3-15V	
Efficiency	See table	
Temperature Coefficient	<+/-0.02%/°C	
Operating Temperature	-40° to +85°C, derating necessary above 60°C	
Storage Temperature	-55° to +125°C	
Thermal Shock	MIL-STD-810F	
Relative Humidity (non condensing)	5 to 95%	
Transient Response (25% step load change)	250µs recovery	
Overvoltage Protection (Zener clamp)	120-130%	
Overcurrent and Short Circuit Protection	Typically at 150%, hiccup with self recovery	
Input Surge Voltage (Maximum for 100ms)	12V input: 36V, 24V input: 50V, 48V input: 100V	
Reflected input ripple (peak to peak)	30mA	
Isolation Voltage Input to Output	1600VDC minimum	
Input (output) to Case	1000VDC minimum	
Isolation Resistance	10 ⁹ Ω minimum	
Isolation Capacitance (max)	1000pF	
Switching Frequency (Fixed)	400kHz typ	
MTBF (BELLCORE TR-NWT-000332)	1,330,000 hours	
Vibration	MIL-STD-810F	
Conducted and Radiated Emissions (2)	EN55022 Level A	
Immunity (3)	EN61000-4-2, -3, -4, -5, -6 Pref Criteria A	
Safety Agency Certifications	IEC60950-1, UL60950-1, EN60950-1, CE Mark	
Size (mm) (L x W x H)	25.4 x 25.4 x 9.9	
Weight (g)	15	
Warranty (yrs)	2	



Model Selector

Model	Output Voltage V	Output Current A	Output Power W	Input Voltage V	Nominal Input Current mA	Efficiency %	Ripple and Noise mVp-p	Max Load Capacitance uF
4:1 INPUT Single Outputs								
PXB15-24WS3P3	3.3V	4.0A	13.2W	9 - 36VDC	688mA	86%	75mVp-p	1000uF
PXB15-48WS3P3	3.3V	4.0A	13.2W	18 - 75VDC	336mA	86%	75mVp-p	1000uF
PXB15-24WS05	5.0V	3.0A	15W	9 - 36VDC	762mA	86%	75mVp-p	1000uF
PXB15-48WS05	5.0V	3.0A	15W	18 - 75VDC	382mA	86%	75mVp-p	1000uF
PXB15-24WS12	12V	1.25A	15W	9 - 36VDC	783mA	87%	100mVp-p	330uF
PXB15-48WS12	12V	1.25A	15W	18 - 75VDC	392mA	87%	100mVp-p	330uF
PXB15-24WS15	15V	1.0A	15W	9 - 36VDC	753mA	87%	100mVp-p	220uF
PXB15-48WS15	15V	1.0A	15W	18 - 75VDC	377mA	87%	100mVp-p	220uF
4:1 INPUT Dual Outputs								
PXB15-24WD05	±5V	1.5A	15W	9 - 36VDC	772mA	85%	100mVp-p	±500uF
PXB15-24WD12	±12V	0.625A	15W	9 - 36VDC	753mA	87%	100mVp-p	±150uF
PXB15-24WD15	±15V	0.5A	15W	9 - 36VDC	744mA	88%	100mVp-p	±100uF
PXB15-48WD05	±5V	1.5A	15W	18 - 75VDC	386mA	85%	100mVp-p	±500uF
PXB15-48WD12	±12V	0.625A	15W	18 - 75VDC	382mA	86%	100mVp-p	±150uF
PXB15-48WD15	±15V	0.5A	15W	18 - 75VDC	377mA	87%	100mVp-p	±100uF
2:1 INPUT Single Outputs								
PXB15-12S3P3	3.3V	4.0A	13.2W	9 - 18VDC	1375mA	84%	75mVp-p	1000uF
PXB15-24S3P3	3.3V	4.0A	13.2W	18 - 36VDC	671mA	86%	75mVp-p	1000uF
PXB15-48S3P3	3.3V	4.0A	13.2W	36 - 75VDC	336mA	86%	75mVp-p	1000uF
PXB15-12S05	5.0V	3.0A	15W	9 - 18VDC	1542mA	86%	75mVp-p	1000uF
PXB15-24S05	5.0V	3.0A	15W	18 - 36VDC	763mA	86%	75mVp-p	1000uF
PXB15-48S05	5.0V	3.0A	15W	36 - 75VDC	372mA	88%	75mVp-p	1000uF
PXB15-12S12	12V	1.25A	15W	9 - 18VDC	1605mA	85%	100mVp-p	330uF
PXB15-24S12	12V	1.25A	15W	18 - 36VDC	783mA	87%	100mVp-p	330uF
PXB15-48S12	12V	1.25A	15W	36 - 75VDC	387mA	88%	100mVp-p	330uF
PXB15-12S15	15V	1.0A	15W	9 - 18VDC	1506mA	87%	100mVp-p	220uF
PXB15-24S15	15V	1.0A	15W	18 - 36VDC	744mA	88%	100mVp-p	220uF
PXB15-48S15	15V	1.0A	15W	36 - 75VDC	372mA	88%	100mVp-p	220uF
2:1 INPUT Dual Outputs								
PXB15-12D05	±5V	±1.5A	15W	9 - 18VDC	1543mA	85%	100mVp-p	±500uF
PXB15-12D12	±12V	±0.625A	15W	9 - 18VDC	1506mA	87%	100mVp-p	±150uF
PXB15-12D15	±15V	±0.5A	15W	9 - 18VDC	1488mA	88%	100mVp-p	±100uF
PXB15-24D05	±5V	±1.5A	15W	18 - 36VDC	772mA	85%	100mVp-p	±500uF
PXB15-24D12	±12V	±0.625A	15W	18 - 36VDC	744mA	88%	100mVp-p	±150uF
PXB15-24D15	±15V	±0.5A	15W	18 - 36VDC	744mA	88%	100mVp-p	±100uF
PXB15-48D05	±5V	±1.5A	15W	36 - 75VDC	386mA	85%	100mVp-p	±500uF
PXB15-48D12	±12V	±0.625A	15W	36 - 75VDC	368mA	89%	100mVp-p	±150uF
PXB15-48D15	±15V	±0.5A	15W	36 - 75VDC	372mA	88%	100mVp-p	±100uF

Specification Notes:

- (1) Output can be trimmed using an external resistor.
- (2) To meet EN55022 Class B external filter components are required. See additional application note.
- (3) To meet EN61000-4-4, EN610004-5 an external filter capacitor is required. See additional application note.

Options

Suffix	Description
P	Positive Logic
N	Negative Logic
T	Trim

-NT as standard Delete suffix if not required



Outline Drawing PXB15 Series

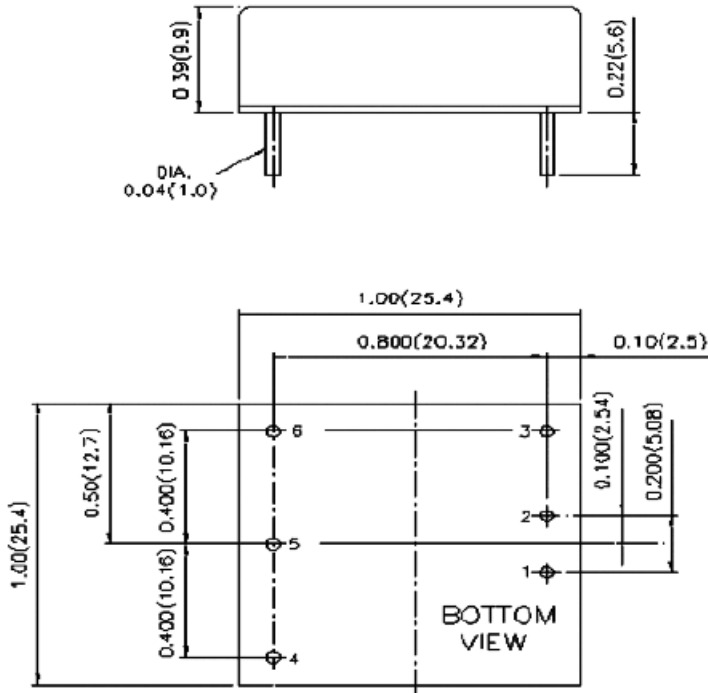

1. All dimensions in inches (mm)
Tolerance: X.XX±0.02 (X.X±0.5)
X.XXX±0.01 (X.XX±0.25)
2. Pin pitch tolerance ±0.01(0.25)
3. Pin dimension tolerance ±0.004 (0.1)

Pinout

Pin#	Function	
	Single Output	Dual Output
1	+ Input	+ Input
2	- Input	- Input
3	Remote On/Off	Remote On/Off
4	+ Output	+ Output
5	Trim	Common
6	- Output	- Output

Derating Curve PXB15 Series

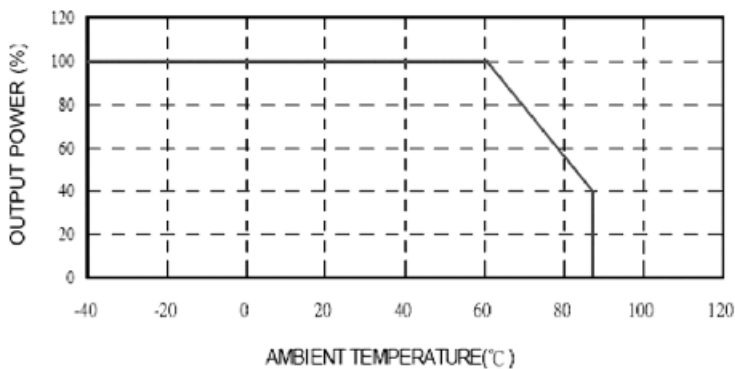

No Heatsink



- Industry Standard 24 Pin Dip Package
- Five Sided Shielding
- Wide Range 4:1 Input
- 3.3, 5, 12, 15 Volt Outputs
- Pin & Surface Mount Models

PXC05 Series

Single and Dual Output 5W
DC-DC Converters

Key Market Segments & Applications

- Telecom
- Datacom
- Factory Automation & Process Control

PXC05 Features and Benefits

Features

- UL, C-UL, TUV, CE approvals
- Wide range input
- Five sided shielding

Benefits

- Easier system approvals
- Less parts to inventory
- Reduced radiated noise

Specifications

ITEMS	PXC05
Max Output Power	5W
Voltage Accuracy	+/-2%
Voltage Adjustment	None
Minimum Load (1)	10%
Line Regulation	+/-0.2%
Load Regulation (25% to 100%)	Single Output: +/-0.5%, Dual Output: +/-1%
Cross Regulation (25% to 100%)	Dual +/-5%
Ripple and Noise	50mVp-p (20MHz bandwidth)
Start up time	600ms
Temperature Coefficient	<+/-0.02%/°C
Operating Temperature	See derating curves
Maximum Case Temperature	+100°C
Storage Temperature	-55°C to +105°C
Thermal Shock	MIL-STD-810D
Relative Humidity (non condensing)	5 to 95%
Transient Response	200µs recovery (25% step load change)
Overvoltage Protection	None
Overcurrent Protection	Typically at 170%, self recovery
Input Surge Voltage (Max for 100ms)	12V input: 36V, 24V input: 50V, 48V input: 100V
Reflected input ripple (peak to peak)(2)	20mA
Isolation Voltage	1600VDC min.
Isolation Resistance	10 ⁹ Ω min.
Isolation Capacitance (max)	300pF
Typical Switching Frequency (Fixed)	300kHz
MTBF (BELLCORE TR-NWT-000332)	3,165,000 hours
Vibration	10 - 55Hz, 2G, 30 minutes each X, Y, Z axis
Conducted and Radiated Emissions	EN55022 Level A
Immunity	EN61000-4-2, -3, -4, -5, -6 Pref Criteria 2
Safety Agency Approval	IEC60950-1, UL/CSA60950-1, EN60950-1, CE Mark
Size mm (L x W x H)	32 x 21 x 11
Weight (g)	DIP 16 SMD 18
Warranty (yrs)	2

Notes: (1) To meet regulation & noise specifications. Operation at zero load will not damage the device

(2) 12µH source impedance in series with + input (3) SMD package: Add suffix "/SMD" to model number.



Model Selector							
Model	Output Voltage (V)	Output Current (mA)	Output Power (W)	Input Voltage (V)	Nominal Input Current (mA)	Efficiency (%)	Max Load Capacity (uF)
Single Outputs							
PXC05-24WS3P3	3.3	1000	3.3	9 - 36VDC	191	76	2200
PXC05-48WS3P3	3.3	1000	3.3	18 - 75VDC	100	73	2200
PXC05-24WS05	5	1000	5	9 - 36VDC	285	77	1000
PXC05-48WS05	5	1000	5	18 - 75VDC	145	76	1000
PXC05-24WS12	12	470	5.64	9 - 36VDC	309	80	220
PXC05-48WS12	12	470	5.64	18 - 75VDC	155	80	220
PXC05-24WS15	15	400	6	9 - 36VDC	329	80	150
PXC05-48WS15	15	400	6	18 - 75VDC	167	79	150
Dual Outputs							
PXC05-24WD05	+/-5	+/-500	5	9 - 36VDC	282	78	+/-680
PXC05-48WD05	+/-5	+/-500	5	18 - 75VDC	145	76	+/-680
PXC05-24WD12	+/-12	+/-230	5.52	9 - 36VDC	295	82	+/-100
PXC05-48WD12	+/-12	+/-230	5.52	18 - 75VDC	151	80	+/-100
PXC05-24WD15	+/-15	+/-190	5.7	9 - 36VDC	313	80	+/-68
PXC05-48WD15	+/-15	+/-190	5.7	18 - 75VDC	159	79	+/-68

DIP Pin Connection			
Pin #	Single	Function	Dual
2	- Input		- Input
3	- Input		- Input
9	NC		Common
10	no pin		no pin
11	NC		- Output
23	+ Input		+ Input
22	+ Input		+ Input
16	- Output		Common
15	no pin		no pin
14	+ Output		+ Output

SMD Pin Connection			
Pin #	Single	Function	Dual
2	- Input		- Input
3	- Input		- Input
9	NC		Common
10	NC		NC
11	NC		- Output
23	+ Input		+ Input
22	+ Input		+ Input
16	- Output		Common
15	NC		NC
14	+ Output		+ Output
Others	NC		NC



Derating Curve PXC05 Series

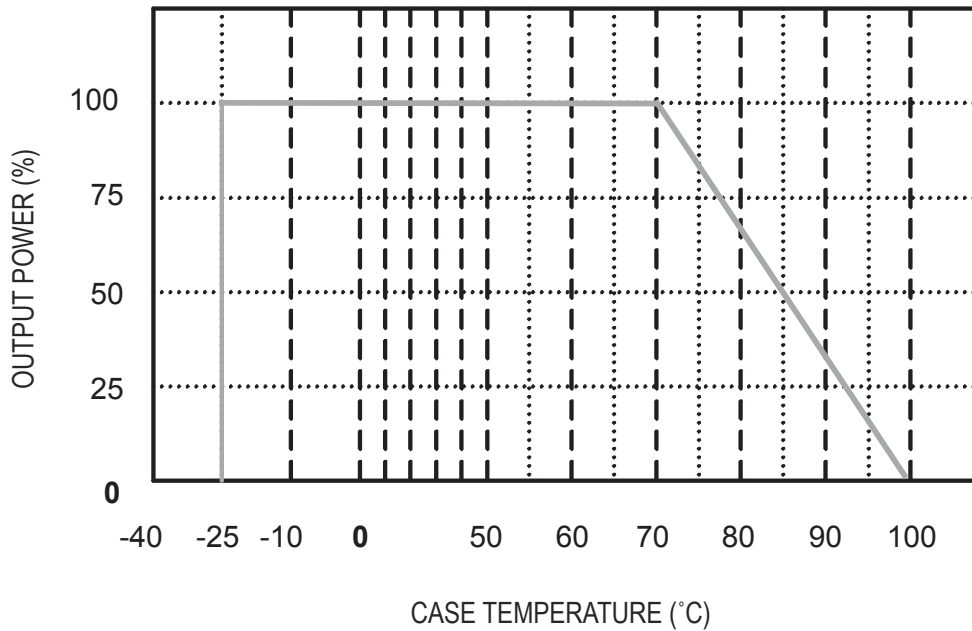

Outline Drawing PXC05 Series

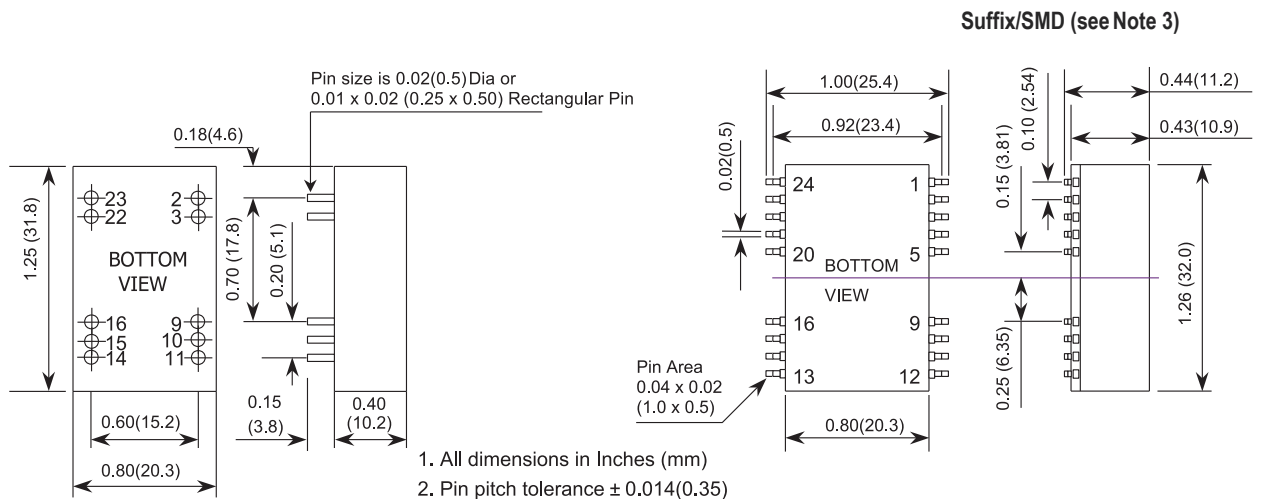



- Industry Standard 2" x 1" Footprint
- Six Sided Shielding
- Agency Approved
- 12V, 24V and 48V Inputs

PXD Series

Single and Dual Output 10 to 20W
DC-DC Converters

Key Market Segments & Applications

- Telecom
- Datacom
- Point of Load

PXD Features and Benefits

Features

- UL, CSA, EN, CE Approvals
- Wide Range Input
- Six Sided Shielding

Benefits

- Easier System Approvals
- Less Parts to Inventory
- Reduced Radiated Noise

Specifications

ITEMS	PXD10	PXD15	PXD20
Max Output Power	10W	15W	20W
Voltage Accuracy	±2%	±1%	±1%
Voltage Adjustment (Single O/P Only)	None	None	±10%
Minimum Load, each output (1)	10%	10%	Single 0%; Dual 10%
Line Regulation	±1%	±1%	±0.2%
Load Regulation (10% to 100%)	Single Output: ±1% Dual Output: ±2%	Single Output: ±1% Dual Output: ±2%	±0.5% -
Cross Regulation (25% to 100%)		±5%	
Ripple and Noise	Single 50mV, Dual 75mV		Single 75mV, Dual 100mV
Start up time	20ms		10ms
Remote on/off (3)	Positive Logic: ON: Open or 3.5-12V, OFF Short or <1.2V Negative Logic: ON: Short or <1.2V, OFF: Open or 3.5-12V		
Temperature Coefficient	<±0.02%/°C		
Operating Temperature	-40°C to +85°C (model dependent - see derating curves)		
Maximum Case Temperature	+100°C		
Storage Temperature	-55°C to +105°C		
Thermal Shock	MIL-STD-810D		
Relative Humidity	5 to 95% (non condensing)		
Transient Response (25% step load chg.)	500µS recovery	500µS recovery	300µS recovery
Overvoltage Protection (Zener clamp)	1.5-3.3V: 3.9V, 5V: 6.2V, 12V: 15V, 15V: 18V		
Overcurrent & Short Circuit Protection	Typically at 150%, hiccup with self recovery		
Input Surge Voltage (Max. for 100ms)	12V input: 36V, 24V input: 50V, 48V input: 100V		
Reflected input ripple (peak to peak) (2)	30mA	20mA	20mA
Isolation Voltage	1600VDC minimum		
Isolation Resistance	109 Ω minimum		
Isolation Capacitance (max)	300pF		1000pF
Typical Switching Frequency (Fixed)	300kHz	Single: 500kHz Dual: 300kHz	500kHz
MTBF (BELLCORE TR-NWT-000332)	1,976,000 hours	2,041,000 hours	1,791,000 hours
Vibration	10 - 55Hz, 2G, 30 minutes each X, Y, Z axis		
Conducted and Radiated Emissions	EN55022 Level A		
Immunity	EN61000-4-2, -3, -4, -5, -6 Pref Criteria 2		
Safety Agency Approval	IEC606950, UL1950, EN60950, CE Mark (48V input only)		
Size mm (L x W x H)	50.8 x 25.4 x 10.2		
Weight (g)	27		
Warranty (yrs)	2		



Specification Notes:

- (1) To meet regulation & noise specifications. Operation at zero load will not damage the device.
- (2) 12μH source impedance in series with + input (3) Positive logic standard on 20W (see options table). Input current 2.5mA

Model Selector						
Output Volt (V)	Output Current (A)	Output Power (W)	Input Volt (V)	Model	Efficiency (%)	
3.3	2.0	6.6	9 - 18VDC	PXD10-12S3P3	80	
3.3	2.0	6.6	18 - 36VDC	PXD10-24S3P3	80	
3.3	2.0	6.6	36 - 75VDC	PXD10-48S3P3	79	
3.3	5.0	16.5	9 - 18VDC	PXD20-12S3P3	84	
3.3	5.0	16.5	18 - 36VDC	PXD20-24S3P3	86	
3.3	5.0	16.5	36 - 75VDC	PXD20-48S3P3	87	
5	2.0	10	9 - 36VDC	PXD10-24WS05	80	
5	2.0	10	18 - 75VDC	PXD10-48WS05	80	
5	4.0	20	9 - 18VDC	PXD20-12S05	87	
5	4.0	20	18 - 36VDC	PXD20-24S05	89	
5	4.0	20	36 - 75VDC	PXD20-48S05	89	
12	0.83	10	9 - 36VDC	PXD10-24WS12	82	
12	0.83	10	18 - 75VDC	PXD10-48WS12	84	
12	1.67	20	9 - 18VDC	PXD20-12S12	85	
12	1.67	20	18 - 36VDC	PXD20-24S12	87	
12	1.67	20	36 - 75VDC	PXD20-48S12	88	
15	0.67	10	9 - 36VDC	PXD10-24WS15	80	
15	0.67	10	18 - 75VDC	PXD10-48WS15	84	
15	1.33	20	9 - 18VDC	PXD20-12S15	85	
15	1.33	20	18 - 36VDC	PXD20-24S15	87	
15	1.33	20	36 - 75VDC	PXD20-48S15	87	
Dual Outputs						
±5	±1.5	15	9 - 18VDC	PXD15-12D05	83	
±5	±1.5	15	18 - 36VDC	PXD15-24D05	84	
±5	±1.5	15	36 - 75VDC	PXD15-48D05	85	
±12	±0.416	10	9 - 36VDC	PXD10-24WD12	80	
±12	±0.416	10	18 - 75VDC	PXD10-48WD12	78	
±12	±0.833	20	9 - 18VDC	PXD20-12D12	86	
±12	±0.833	20	18 - 36VDC	PXD20-24D12	87	
±12	±0.833	20	36 - 75VDC	PXD20-48D12	88	
±15	±0.333	10	9 - 36VDC	PXD10-24WD15	80	
±15	±0.333	10	18 - 75VDC	PXD10-48WD15	81	
±15	±0.667	20	9 - 18VDC	PXD20-12D15	86	
±15	±0.667	20	18 - 36VDC	PXD20-24D15	87	
±15	±0.667	20	36 - 75VDC	PXD20-48D15	87	

* OTHER MODELS AVAILABLE ON REQUEST *

Pinout		
Pin#	Function	
	Single Output	Dual Output
1	+ Input	+ Input
2	- Input	- Input
3	+ Output	+ Output
4	Trim (20W only)	Common
5	- Output	- Output
6	Remote On/Off	Remote On/Off

Notes:

- (1) With external ceramic capacitor (24V: 4.7μF, 48V: 2.2μF) connected across input pins
- (2) For EN61000-4-4 & -5 compliance fit external electrolytic capacitor (24V: 330μF, 48V: 220μF) connected across input pins

Remote On/Off Options	
Suffix	Function
-P*	Positive Logic
-N	Negative Logic
Example: PXD1548S12-N * Included in PXD20 models	

Notes:

- Remote On/Off is optional on PXD-10 and PXD-15 (add suffix -P or -N if required)
- Remote On/Off positive Logic is standard on PXD-20 (add suffix -N if negative logic required)



Outline Drawing PXD Series

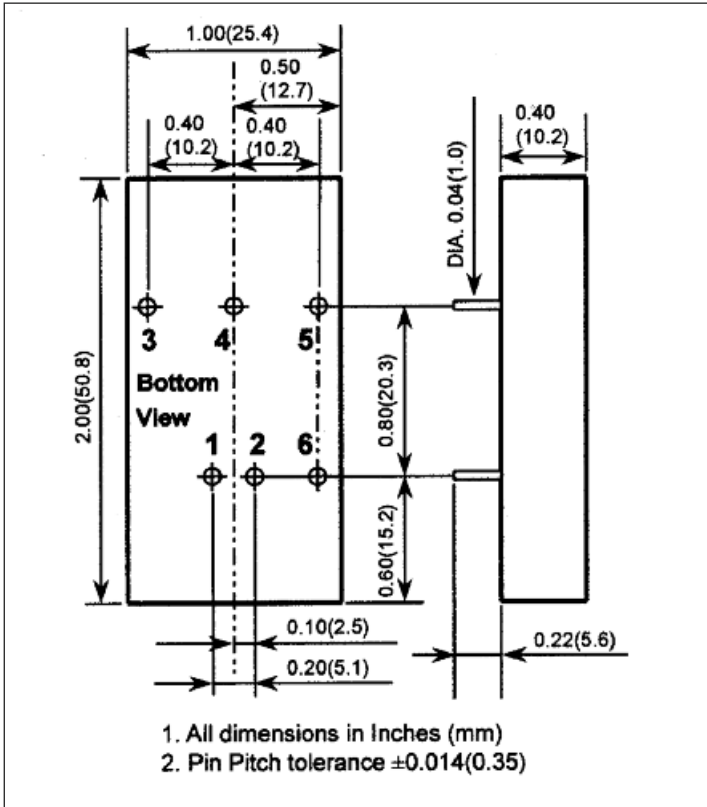

Derating Curves PXD Series

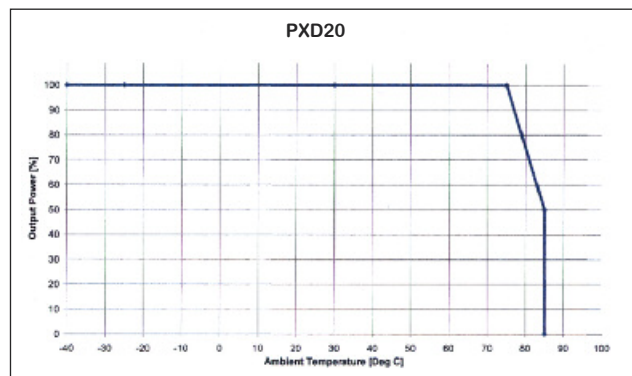
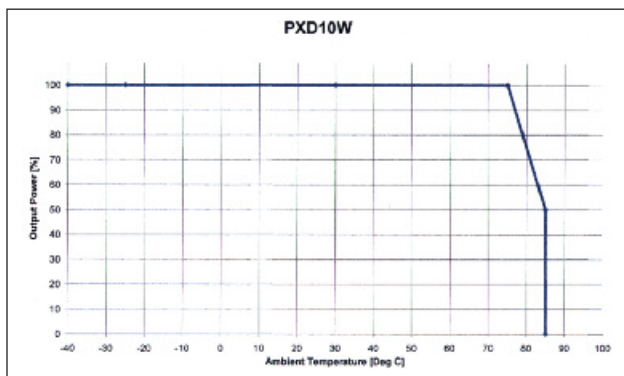
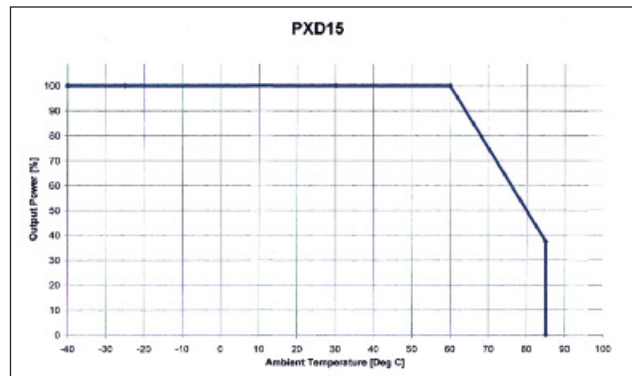
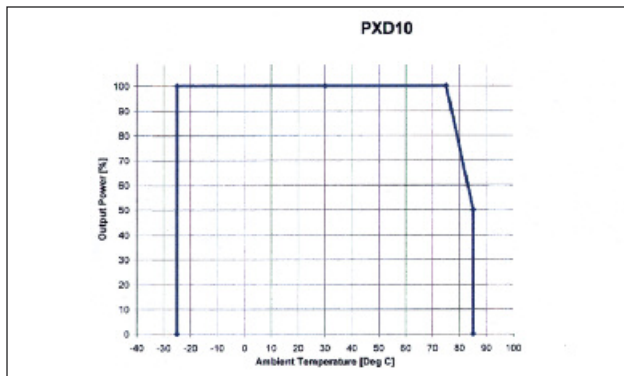



- Industry Standard 2" x 1" Footprint
- Six Sided Shielding
- Safety Agency Certifications
- 9-36V or 18-75VDC Input

PXD30W Series

Single and Dual output 30W
DC-DC converters

Key Market Segments & Applications

- Telecom
- Datacom
- Process Control

PXD30W Features and Benefits

Features

- Safety Certification
- Wide range input
- Six sided shielding

Benefits

- Easier system approvals
- Less parts to inventory
- Reduced radiated noise

Specifications	Single Output	Dual Output
ITEMS		
Max Output Power		30W
Voltage Accuracy		±1%
Voltage Adjustment	±10%	None
Minimum Load		None
Line Regulation		±0.2%
Load Regulation	±0.5%	±1%
Cross Regulation (25% to 100%)	-	±5%
Ripple and Noise	<5.1V output: 100mV, 12-15V output: 150mV	
Start up time	30ms	
Remote on/off	Positive Logic: ON: Open or 3-12V, OFF Short or <1.2V Negative Logic: ON: Short or <1.2V, OFF: Open or 3-12V	
Temperature Coefficient	<+/-0.02%/°C	
Operating Temperature	-40°C to +85°C, derating necessary above 50°C	
Maximum Case Temperature	+105°C (Overtemperature Protection +115°C)	
Storage Temperature	-55°C to +125°C	
Thermal Shock	MIL-STD-810F	
Relative Humidity (non condensing)	5 to 95%	
Transient Response (25% step load change)	250µs recovery	
Overvoltage Protection (Zener clamp)	5V: 6.2V, 12V: 15V, 15V: 18V	
Overcurrent and Short Circuit Protection	Typically at 150%, hiccup with self recovery	
Input Surge Voltage (Maximum for 100ms)	24V input: 50V, 48V input: 100V	
Reflected input ripple (peak to peak)	20mA	
Isolation Voltage	1600VDC minimum	
Isolation Resistance	10 ⁹ Ω minimum	
Isolation Capacitance (max)	1500pF	
Typical Switching Frequency (Fixed)	430kHz	
MTBF (BELLCORE TR-NWT-000332)	3,163,000 hours	
Vibration	MIL-STD-810F	
Conducted and Radiated Emissions (1)	EN55022 Level A	
Immunity (2)	EN61000-4-2, -3, -4, -5, -6 Pref Criteria A	
Safety Agency Certifications	IEC60950-1, UL60950-1, EN60950-1, CE Mark	
Size mm (L x W x H)	50.8 x 25.4 x 10	
Weight (g)	30.5	
Warranty (yrs)	2	



Model Selector					
Output Volt (V)	Output Curr (A)	Output Power (W)	Input Volt (V)	Model	Eff.(%)
Single Outputs					
3.3V	7.5A	24.75W	9 - 36VDC	PXD30-24WS3P3	86%
3.3V	7.5A	24.75W	18 - 75VDC	PXD30-48WS3P3	86%
5V	6.0A	30W	9 - 36VDC	PXD30-24WS05	88%
5V	6.0A	30W	18 - 75VDC	PXD30-48WS05	88%
12V	2.5A	30W	9 - 36VDC	PXD30-24WS12	89%
12V	2.5A	30W	18 - 75VDC	PXD30-48WS12	90%
15V	2.0A	30W	9 - 36VDC	PXD30-24WS15	89%
15V	2.0A	30W	18 - 75VDC	PXD30-48WS15	91%
Dual Outputs					
±5V	±3.0A	30W	9 - 36VDC	PXD30-24WD05	88%
±5V	±3.0A	30W	18 - 75VDC	PXD30-48WD05	88%
±12V	±1.25A	30W	9 - 36VDC	PXD30-24WD12	87%
±12V	±1.25A	30W	18 - 75VDC	PXD30-48WD12	88%
±15V	±1.0A	30W	9 - 36VDC	PXD30-24WD15	87%
±15V	±1.0A	30W	18 - 75VDC	PXD30-48WD15	88%

Specification Notes:

- (1) With external ceramic capacitor (24V: 4.7uF, 48V: 2.2uF) connected across input pins
- (2) For EN61000-4-4 & -5 compliance fit external electrolytic capacitor (24V: 330uF, 48V: 220uF) connected across input pins

Remote On/Off Options	
Suffix	Function
No Suffix	Positive Logic
-N	Negative Logic



Outline Drawing PXD30W Series

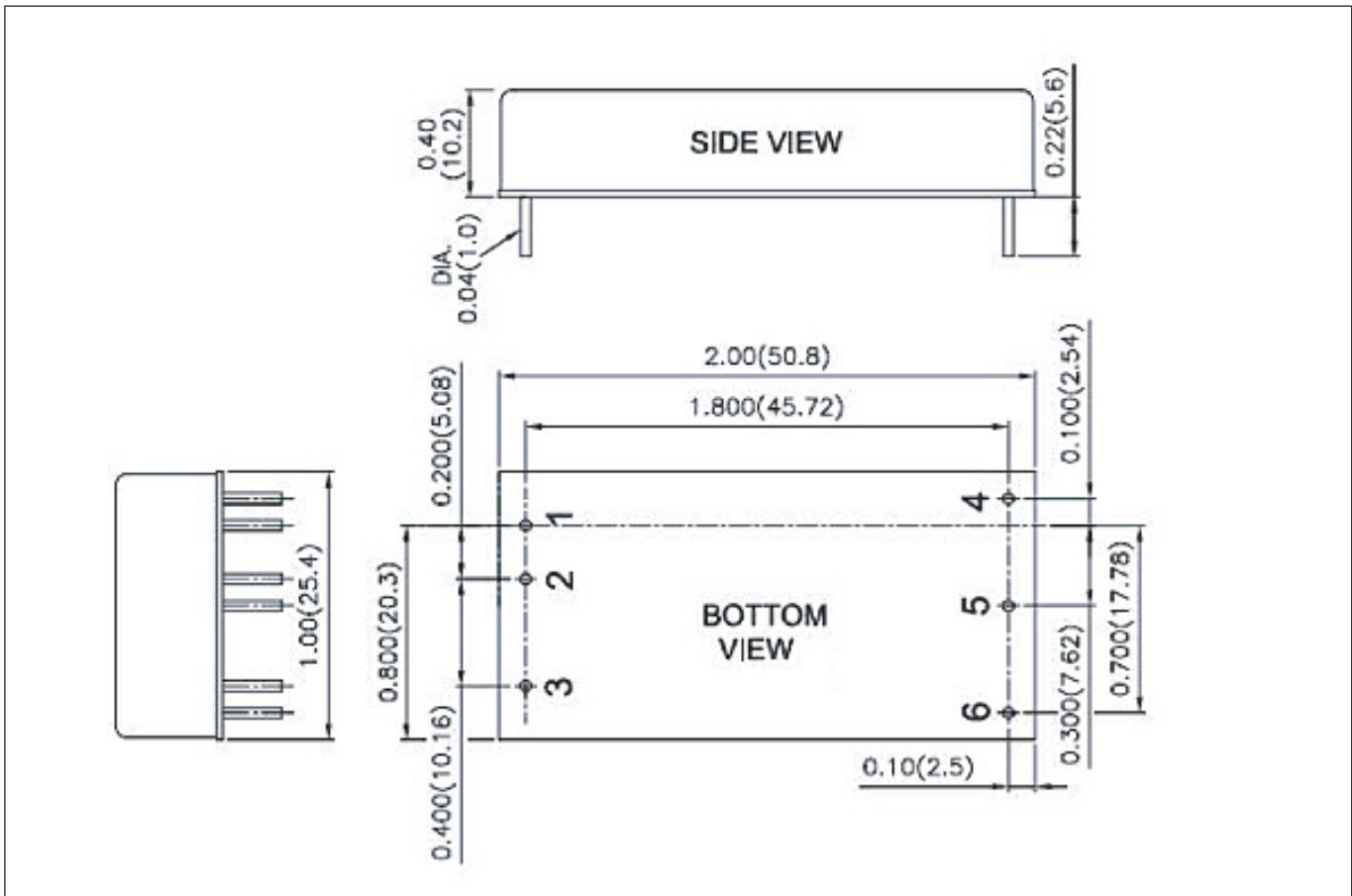

Pinout		
Pin#	Function	
	Single Output	Dual Output
1	+ Input	+ Input
2	- Input	- Input
3	Remote On/Off	Remote On/Off
4	+ Output	+ Output
5	- Output	Common
6	Trim	- Output

Derating Curve PXD30W Series

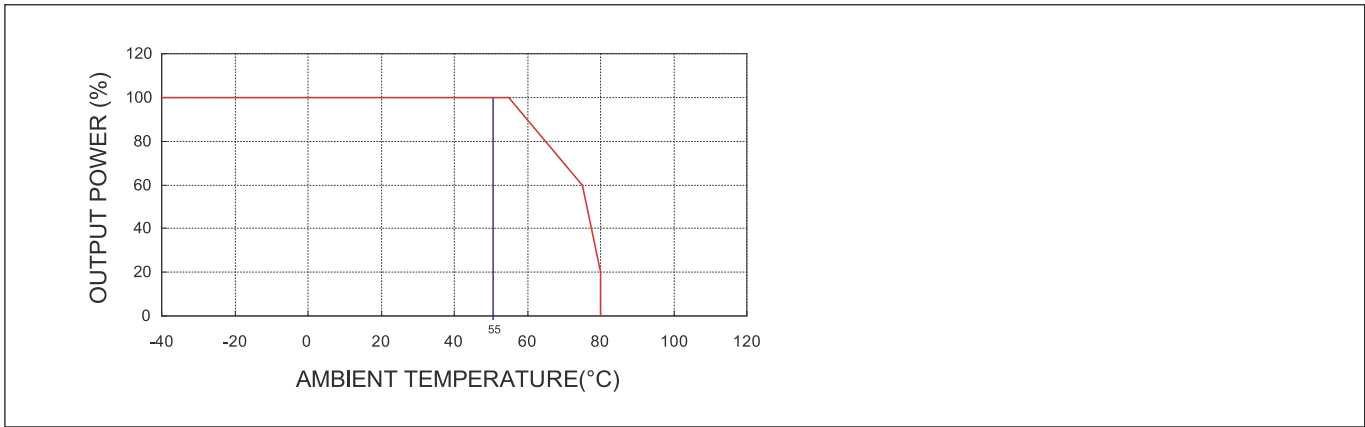

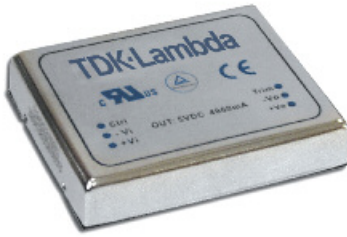

- Industry Standard 2" x 1.6" Footprint
- Six Sided Shielding
- Agency Approved
- 12V, 24V and 48V Inputs

PXE Series

Single and Dual 20W to 30W
DC-DC Converters

Key Market Segments & Applications

- Telecom
- Datacom
- Point of Load

PXE Features and Benefits

Features

- UL, CSA, EN, CE Approvals
- Wide Range Input
- Six Sided Shielding

Benefits

- Easier System Approvals
- Less Parts to Inventory
- Reduced Radiated Noise

Specifications

ITEMS	PXE20	PXE30
Max Output Power	20W	30W
Voltage Accuracy	±2%	±1%
Voltage Adjustment	±10%	
Minimum Load, each output (1)	10%	None
Line Regulation	±0.2% for single, ±0.5% for dual	
Load Regulation (25% to 100%)	Single ±0.5%, Dual ±3%	Single ±0.5%, Dual ±1%
Cross Regulation (25% to 100%)	Dual ±5%	
Ripple and Noise (P-P)	Single: 75mV; Dual: 100mV	
Start up time	20ms typ.	25ms typ.
Remote on/off (3)	Positive Logic: ON: Open or 3.5-12V, OFF Short or <1.2V	
Temperature Coefficient	<±0.02%/°C	
Operating Temperature	-40°C to +85°C	
Maximum Case Temperature	+100°C	
Storage Temperature	-55°C to +105°C	
Thermal Shock	MIL-STD-810D	
Relative Humidity (non condensing)	5 to 95%	
Transient Response (25% step load change)	500µs recovery	300µs recovery
Overvoltage Protection (Zener clamp)	3.3V: 3.9V, 5V: 6.2V, 12V: 15V, 15V: 18V	
Overcurrent and Short Circuit Protection	Typically at 150%, hiccup with self recovery	
Input Surge Voltage (Maximum for 100ms)	12V input: 36V, 24V input: 50V, 48V input: 100V	
Reflected input ripple (peak to peak) (2)	25mA	30mA
Isolation Voltage	1600VDC minimum (Input-Output, Input-Case)	
Isolation Resistance	10 ⁹ Ω minimum	
Isolation Capacitance (max)	300pF	1000pF
Typical Switching Frequency (Fixed)	300kHz	
MTBF (BELLCORE TR-NWT-000332)	1,976,000 hours	1,535,000 hours
Vibration	10 - 55Hz, 2G, 30 minutes each X, Y, Z axis	
Conducted and Radiated Emissions	EN55022 Level A	
Immunity	EN61000-4-2, -3, -4, -5, -6 Pref Criteria 2	
Safety Agency Approval	IEC606950, UL1950, EN60950, CE Mark (48V input only)	
Size mm (L x W x H)	50.8 x 40.6 x 10.2	
Weight (g)	48	
Warranty (yrs)	2	

Notes: (1) To meet regulation & noise specifications. Operation at zero load will not damage the device.
 (3) Max sink current 20mA (PXE20), 2.5mA (PXE30); The on/off pin is referenced to the negative input

(2) 12µH source impedance in series with + input



Model Selector					
Output Volt (V)	Output Curr (A)	Output Power (W)	Input Volt (VDC)	Model	Efficiency (%)
Single Outputs					
1.5	8.0	30	10 - 40	PXE30-24WS1P5	80
1.5	8.0	30	18 - 75	PXE30-48WS1P5	80
1.8	8.0	30	10 - 40	PXE30-24WS1P8	83
1.8	8.0	30	18 - 75	PXE30-48WS1P8	83
2.5	8.0	30	10 - 40	PXE30-24WS2P5	85
2.5	8.0	30	18 - 75	PXE30-48WS2P5	86
3.3	6.0	18	9 - 18	PXE30-12S3P3	85
3.3	6.0	18	18 - 36	PXE30-24S3P3	88
3.3	6.0	18	36 - 75	PXE30-48S3P3	87
3.3	6.0	30	10 - 40	PXE30-24WS3P3	87
3.3	6.0	30	18 - 75	PXE30-48WS3P3	87
3.3	6.0	30	10 - 40	PXE30-24WS2P3	87
5	4.0	20	9 - 36	PXE20-24WS05	79
5	4.0	20	18 - 75	PXE20-48WS05	80
5	6.0	30	9 - 18	PXE30-12S05	87
5	6.0	30	18 - 36	PXE30-24S05	88
5	6.0	30	36 - 75	PXE30-48S05	89
5	6.0	30	10 - 40	PXE30-24WS05	87
5	6.0	30	18 - 75	PXE30-48WS05	88
12	1.67	20	9 - 36	PXE20-24WS12	81
12	1.67	20	18 - 75	PXE20-48WS12	81
12	2.5	30	9 - 18	PXE30-12S12	88
12	2.5	30	18 - 36	PXE30-24S12	89
12	2.5	30	36 - 75	PXE30-48S12	90
12	2.5	30	10 - 40	PXE30-24WS12	87
12	2.5	30	18 - 75	PXE30-48WS12	87
15	1.33	20	9 - 36	PXE20-24WS15	81
15	1.33	20	18 - 75	PXE20-48WS15	81
15	2.0	30	9 - 18	PXE30-12S15	88
15	2.0	30	18 - 36	PXE30-24S15	89
15	2.0	30	36 - 75	PXE30-48S15	90
15	2.0	30	10 - 40	PXE30-24WS15	88
15	2.0	30	18 - 75	PXE30-48WS15	88
Dual Outputs					
±5	±2.0	20	9 - 36	PXE20-24WD05	79
±5	±2.0	20	18 - 75	PXE20-48WD05	79
±12	±0.833	20	9 - 36	PXE20-24WD12	81
±12	±0.833	20	18 - 75	PXE20-48WD12	83
±12	±1.25	30	9 - 18	PXE30-12D12	87
±12	±1.25	30	18 - 36	PXE30-24D12	88
±12	±1.25	30	36 - 75	PXE30-48D12	88
±12	±1.25	30	10 - 40	PXE30-24WD12	84
±12	±1.25	30	18 - 75	PXE30-48WD12	85
±15	±0.666	20	9 - 36	PXE20-24WD15	82
±15	±0.666	20	18 - 75	PXE20-48WD15	84
±15	±1.0	30	9 - 18	PXE30-12D15	87
±15	±1.0	30	18 - 36	PXE30-24D15	88
±15	±1.0	30	36 - 75	PXE30-48D15	88
±15	±1.0	30	10 - 40	PXE30-24WD15	85
±15	±1.0	30	18 - 75	PXE30-48WD15	86



Outline Drawing PXE Series

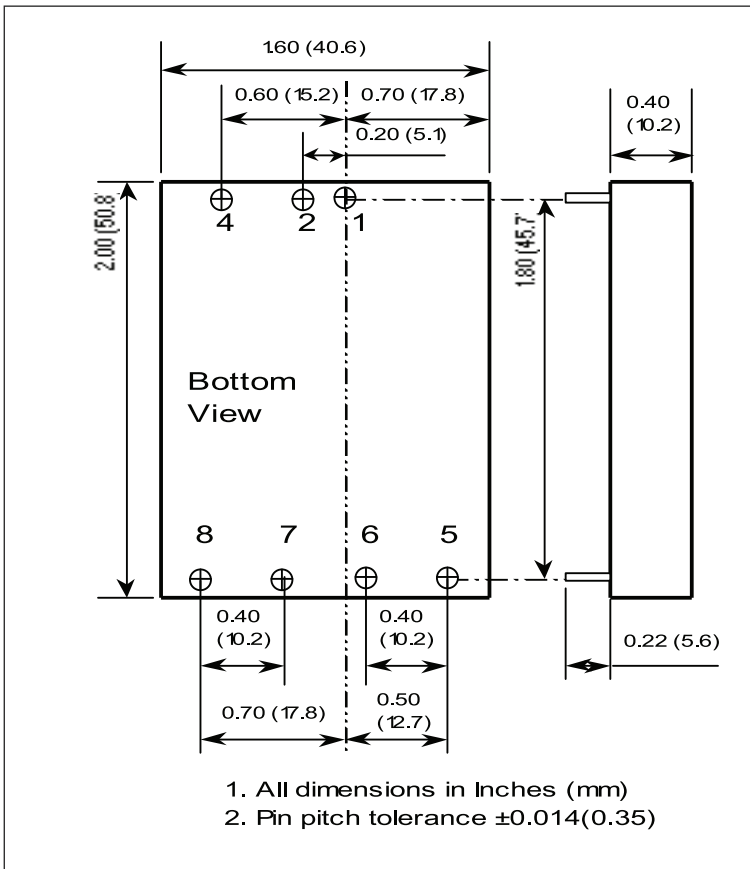

Pinout

PIN #	Function	
	Single Output	Dual Output
1	+ Input	+ Input
2	- Input	- Input
4	Remote on/off	Remote on/off
5	No Pin	+ Output
6	+ Output	Common
7	- Output	- Output
8	Trim	Trim

Derating Curve PXE20 Series

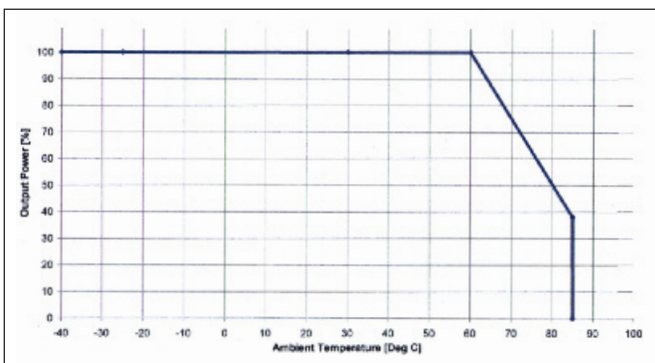

Derating Curve PXE30 Series

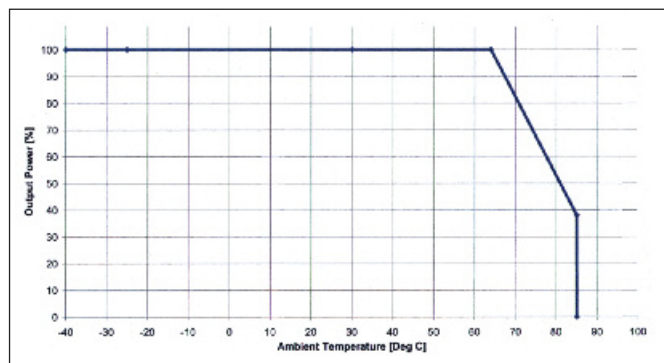



- Industry Standard 2" x 2" Footprint
- Six Sided Shielding
- Agency Approved
- 12, 24 and 48V Inputs
- 4:1 Wide Range Input Models

PXF Series

Single, Dual, Triple Output 40W & 60W
DC-DC Converters

Key Market Segments & Applications

Telecom
Datacom
Point of Load

PXF Features and Benefits

Features

- UL, CSA, EN, CE Approvals
- Wide Range Input
- Six Sided Shielding

Benefits

- Easier System Approvals
- Less Parts to Inventory
- Reduced Radiated Noise

Specifications

ITEMS	PXF
Maximum Output Power	40W or 60W
Voltage Accuracy (Full Load, Nom. Vin)	Single, Dual and Triple Main $\pm 1\%$, Triple Auxiliaries $\pm 5\%$
Voltage Adjustment (1)	$\pm 10\%$ (Single and Dual Output Only)
Minimum Load, each output (2)	Single Output = 0%, Dual and Triple = 10% of full load rating
Line Regulation	Single / Dual $\pm 0.5\%$, Triple (main) $\pm 1\%$, Triple (auxiliary) $\pm 5\%$
Load Regulation (10% to 100%) (3)	Single $\pm 0.5\%$, Dual $\pm 1\%$, Triple (main) $\pm 2\%$, Triple (auxiliary) $\pm 5\%$
Cross Regulation (25% to 100%) (4)	Triple (main) $\pm 1\%$, Dual/Triple (auxiliary) $\pm 5\%$
Start up time	PXF40: 25ms typ., PXF40xxW, PXF60: 20ms max.
Remote on/off (referenced to negative input)	Positive Logic: ON: Open or 3.0-12V, OFF Short or <1.2V
Temperature Coefficient	$< \pm 0.02\%/^{\circ}\text{C}$
Operating Temperature	See derating curves
Maximum Case Temperature	PXF40: $+100^{\circ}\text{C}$, PXF40-xxW $+105^{\circ}\text{C}$, PXF60 $+110^{\circ}\text{C}$
Storage Temperature	PXF40: -55°C to $+105^{\circ}\text{C}$, PXF40xxW, PXF60 $+125^{\circ}\text{C}$
Thermal Shock	MIL-STD-810F
Relative Humidity (non condensing)	5 to 95%
Transient Response (25% step load change)	250 μs recovery
Overvoltage Protection (Zener clamp)	Typical 3.3V: 3.9V, 5V: 6.2V, 12V: 15V, 15V: 18V
Overcurrent and Short Circuit Protection	Typically at 150%, hiccup with self recovery
Input Surge Voltage (Maximum for 100ms)	12V input: 36V, 24V input: 50V, 48V input: 100V
Reflected input ripple (peak to peak) (6)	PXF40: 40mA, PXF40xxW, PXF60: 20mA
Isolation Voltage	Input - Output, Input to Case: 1600VDC minimum
Isolation Resistance	10 ⁹ Ω minimum
Isolation Capacitance (max)	PXF40, PXF60: 1000pF, PXF40xxW: 2500pF
Switching Frequency (Fixed)	300kHz (typ.)
MTBF (BELLCORE TR-NWT-000332)	PXF40: 1,398,000; PXF40xxW: 1,105,000, PXF60: 1.093,000 hours
Vibration	10 - 55Hz, 10G, 30 minutes each X, Y, Z axis
Conducted and Radiated Emissions	EN55022 Level A, see installation manual
Immunity	EN61000-4-2, -3, -4, -5, -6
Safety Agency Approval	IEC60950-1, UL60950-1, EN60950-1, CE Mark (48V input only)
Size mm (L x W x H)	50.8 x 50.8 x 10.1
Weight (g)	60
Warranty (yrs)	2



- (1) Maximum output deviation is 10% inclusive of remote sense and trim. If remote sense is not being used, the +Sense and - Sense should be connected to their corresponding outputs; + output, - output.
- (2) Dual and Triple output models require a minimum load of 10% on the output to maintain specified regulation. No load operation will not damage the device.
- (3) Load regulation for triple output: Main output:10-100%, with 10-100% balanced load on auxiliaries. Auxiliary outputs: 10% to 100% balanced on all outputs.
- (4) Cross regulation for dual output: asymmetrical load 25% / 100% full load. Cross regulation for triple output: Main output 100% load, auxiliary 100%, other auxiliary 25% to 100%. Auxiliary outputs: main output 100% load, auxiliary 100%, other auxiliary 25% to 100% or main output 25%, auxiliary 25%, other auxiliary 25% to 100%.
- (5) An external filter capacitor is required for normal operation. The capacitor should be capable of handling a 1A ripple current for 48V and 24V models.
- (6) Simulated Source impedance of 12 μ H placed in series with + input.

Model Selector						
Output Volt(V)	Output Curr(A)	Input Volt(VDC)	Model	Ripple/Noise (mV)	Efficiency (%)	Max Load Cap(uF)
Single Outputs						
3.3	8	9 - 18	PXF40-12S3P3	50	84	21000
3.3	10	9 - 36	PXF40-24WS3P3	50	86	25750
3.3	8	18 - 36	PXF40-24S3P3	50	87	21000
3.3	10	18 - 75	PXF40-48WS3P3	50	86	25750
3.3	14	18 - 36	PXF60-24S3P3	75	89	36000
3.3	8	36 - 75	PXF40-48S3P3	50	88	21000
3.3	14	36 - 75	PXF60-48S3P3	75	89	36000
5	8	9 - 18	PXF40-12S05	50	86	13600
5	8	9 - 36	PXF40-24WS05	50	87	13600
5	8	18 - 36	PXF40-24S05	50	89	13600
5	8	18 - 75	PXF40-48WS05	50	88	13600
5	8	36 - 75	PXF40-48S05	50	90	13600
5	12	18 - 36	PXF60-24S05	75	90	20400
5	12	36 - 75	PXF60-48S05	75	90	20400
12	3.333	9 - 18	PXF40-12S12	75	86	2360
12	3.333	9 - 36	PXF40-24WS12	75	87	2360
12	3.333	18 - 36	PXF40-24S12	75	88	2360
12	3.333	18 - 75	PXF40-48WS12	75	87	2360
12	3.333	36 - 75	PXF40-48S12	75	89	2360
12	5	18 - 36	PXF60-24S12	100	90	3550
12	5	36 - 75	PXF60-48S12	100	90	3550
15	2.666	9 - 18	PXF40-12S15	75	87	1510
15	2.666	9 - 36	PXF40-24WS15	75	87	1510
15	2.666	18 - 36	PXF40-24S15	75	89	1510
15	2.666	18 - 75	PXF40-48WS15	75	87	1510
15	2.666	36 - 75	PXF40-48S15	75	89	1510
15	4	18 - 36	PXF60-24S15	100	90	2300
15	4	36 - 75	PXF60-48S15	100	90	2300
Dual Outputs						
±12	±1.667	9 - 36	PXF40-24WD12	120	86	±1200
±12	±1.8	9 - 18	PXF40-12D12	120	85	±1200
±12	±1.8	18 - 36	PXF40-24D12	120	87	±1200
±12	±1.667	18 - 75	PXF40-48WD12	120	86	±1200
±12	±1.8	36 - 75	PXF40-48D12	120	87	±1200
±15	±1.333	9 - 36	PXF40-24WD15	150	86	±750
±15	±1.4	9 - 18	PXF40-12D15	150	85	±750
±15	±1.4	18 - 36	PXF40-24D15	150	87	±750
±15	±1.333	18 - 75	PXF40-48WD15	150	86	±750
±15	±1.4	36 - 75	PXF40-48D15	150	87	±750
Triple Outputs						
3.3V,±12V	6.0,±0.4	9 - 18	PXF40-12T3312	50 / 75	83	13000,±330
3.3V,±12V	6.0,±0.4	18 - 36	PXF40-24T3312	50 / 75	85	13000,±330
3.3V,±12V	6.0,±0.4	36 - 75	PXF40-48T3312	50 / 75	86	13000,±330
5V,±12V	6.0,±0.4	9 - 18	PXF40-12T0512	50 / 75	85	6800, ±330
5V,±12V	6.0,±0.4	18 - 36	PXF40-24T0512	50 / 75	87	6800, ±330
5V,±12V	6.0,±0.4	36 - 75	PXF40-48T0512	50 / 75	88	6800, ±330
5V, ±15V	6.0, ±0.3	9 - 18	PXF40-12T0515	50/75	86	6800, ±110
5V, ±15V	6.0, ±0.3	18 - 36	PXF40-24T0515	50/75	87	6800, ±110
5V, ±15V	6.0, ±0.3	36 - 75	PXF40-48T0515	50/75	88	6800, ±110



Outline Drawing PXF Series

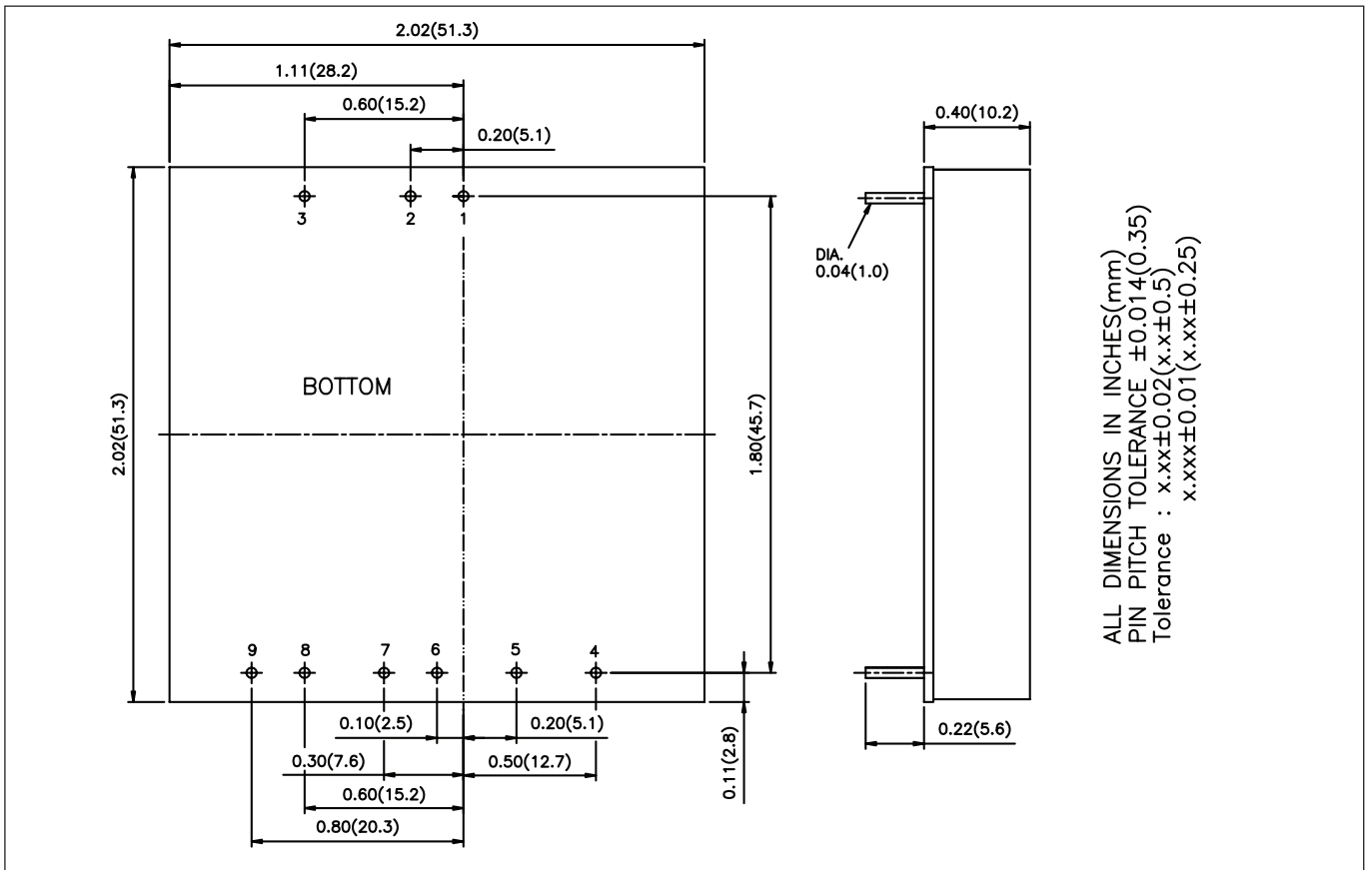

Derating Curve PXF40 Series

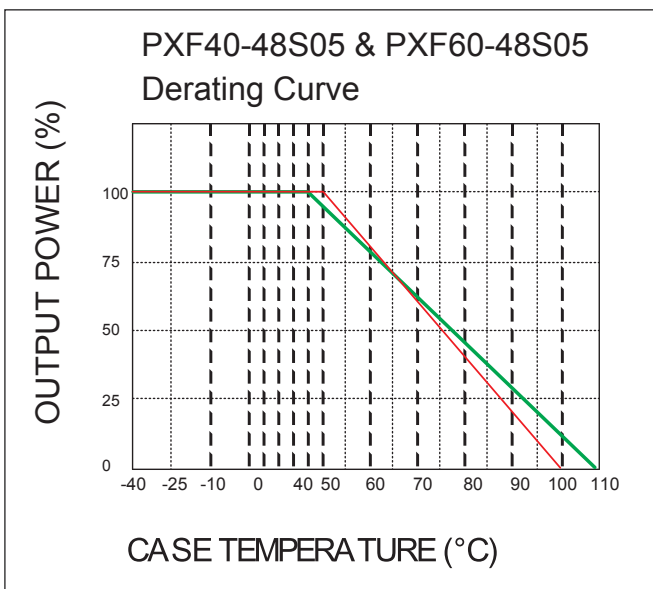

Pinout			
PIN#	Single O/P	Function Dual O/P	Triple O/P
1	+ Input	+ Input	+ Input
2	- Input	- Input	- Input
3	Remote on/off	Remote on/off	Remote on/off
4	No Pin	No Pin	+ Aux
5	- Sense (Note 1)	+ VO	Common
6	+ Sense (Note 1)	Common	-Aux
7	+ Output	Common	+ Output
8	- Output	- VO	- Output (Com)
9	Trim	Trim	N/C

Heat Sink (5.58mm high)
 7G0026A (includes thermal adhesive pad)



Non-isolated POL (point of load) PCB mount & Surface Mount DC-DC Converters

Point of Load converters from 1.5A to 20A output current with trimmable output voltage.

Preset fixed output voltage optional on some models.

Nominal 5V and nominal 12V wide input ranges on most models whilst the CE-1050 accepts up to 26.4V input.

Suitable for many distributed power architecture applications.

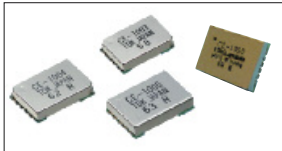

CE1000/1050 Series 1.75 - 30W Single Output

Page No.

245



iAA/iAC Series 11 - 80W Single Output

248

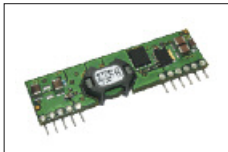

iAD Series 80W Single Output

251

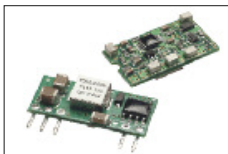

PL5 Series 3.75W - 25W Single Output

253

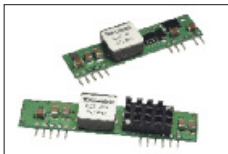

PL10-20S Series 7.5W - 100W Single Output

256

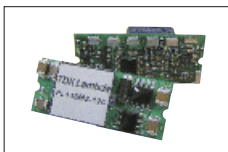

PL10-20SMS Series 7.5W - 100W Single Output

259



- 3 to 5V or 9 to 26V Input
- Outputs 1V to 12V
- Surface Mount
- Low 4.2mm to 5.5mm Profile
- Non Isolated Output

CE Series

1.2 - 2.5A Point of Load Converters

Key Market Segments & Applications

- Telecommunications
- Datacom
- Instrumentation

CE Series Features and Benefits

Features

- Wide range output
- Constant switching frequency
- Five sided shielding

Benefits

- Reduces need for custom models
- Easier system filtering
- Reduced EMI

Specifications

MODELS		CE-1003	CE-1004	CE-1005	CE-1050
ITEMS					
Nominal Output Voltage VDC		1.5 to 3.3	3.3 to 5.0	1 to 3.3	(2) 3.3 tp 12.6
Input Voltage Range VDC		6 - 16		3 - 5.25	9 - 26.4
Input Current (max)	A	2.4			1.8
Ripple & Noise (typ) (pk - pk)	mV	100		50	
Total Regulation (max)	mV	±5%		±4%	±5%
Overload Protection (typ)	A	2		3	3.5
Remote On / Off (1)	-	ON = 2 - 6V; OFF= 0-0.6V		ON = <0.5V; OFF= >2V	ON = 3 -6V; OFF= 0-0.3V
Temperature (operating)	°C	-40°C to +85°C (CE1003, 80% load above 70°C)			-20°C to +85°C
Temperature (storage)	°C	-40°C to +85°C			-20°C to +85°C
Humidity (operating)	-	10 - 90% RH Non condensing @ max temp +38°C			
Humidity (storage)	-	Sealed packaging, see Technical Download			
Cooling	-	Convection or forced air			
Vibration (non operating)	-	Frequency: 10-2000Hz, Sweep time: 4 minutes per cycle Amplitude: 10G, 30 minutes each x, y, and z direction			
Shock	-	Peak Acceleration: 100G, Duration: 6msec; three times each axis			
Weight (max)	g	1.8		1.7	3.7
Size	mm	18.3 x 12.3 x 4.2			21.3 x 16.4 x 5.5
Warranty	yrs	1			

Notes: (1) Pin 5
(2) Input / output voltage differential must be at least 4V.



Model Selector

Model	Output Voltage (V)	Output Current (A)	Efficiency (typ)
CE-1003	1.5 - 3.3 ⁽²⁾	1.5	86.5%
CE-1004	3.3 - 5 ⁽²⁾	1.5	86.5%
CE-1005	1.0 - 3.3	2.5 ⁽³⁾	91.5%
CE-1050	3.3 - 12.6	2.5 ⁽⁴⁾	90.0%

Notes:

- (2) See Programming Table
- (3) See CE-1005 Derating Table
- (4) See CE-1050 Derating Curves

CE-1005 Derating Table

Vout	3.3 Vin	5.0 Vin
1.0	1.75A	1.5A
1.2	1.85A	1.65A
1.5	2.00A	1.85A
1.8	2.15A	2.0A
2.0	2.25A	2.2A
2.5	2.50A	2.5A
3.3	-	2.5A

CE-1003, 1004 Programming Table

Pin 7	Pin 8	Pin 9	Output Voltage CE-1003	(Vout) CE-1004
0	0	0	3.3	5.0
0	0	1	3.0	4.8
0	1	0	2.8	4.5
0	1	1	2.5	4.3
1	0	0	2.3	4.0
1	0	1	2.0	3.8
1	1	0	1.8	3.5
1	1	1	1.5	3.3

0 = Short to GND 1 = Open
See web site for detailed specifications

CC-1005 can be trimmed with external resistor

Derating Curve CE-1050 Series

Vout=3.3V

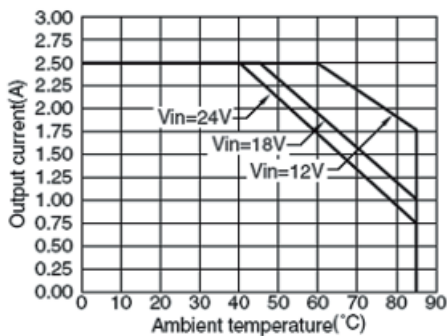

Vout=9.0V

Vout=9.0V

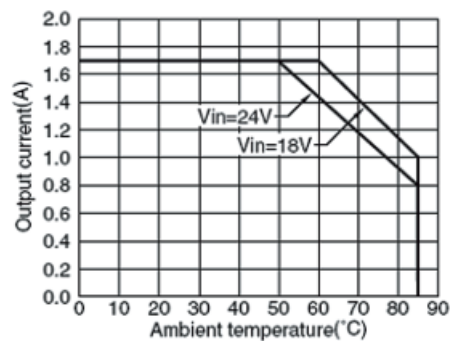

Vout=5.0V

Vout=5.0V

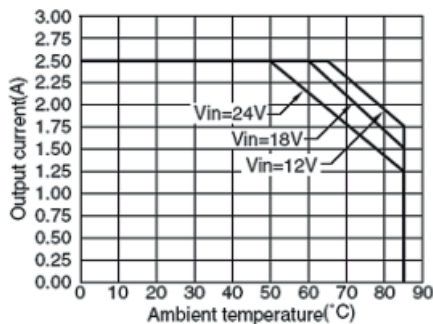

Vout=12V

Vout=12V

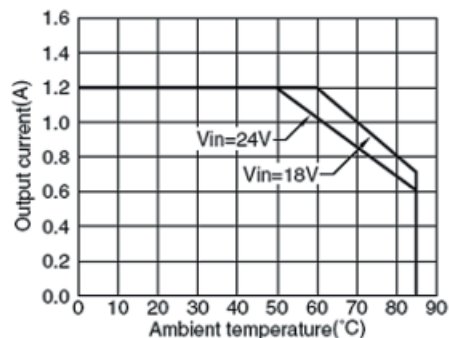



Outline Drawing CE-1000 Series

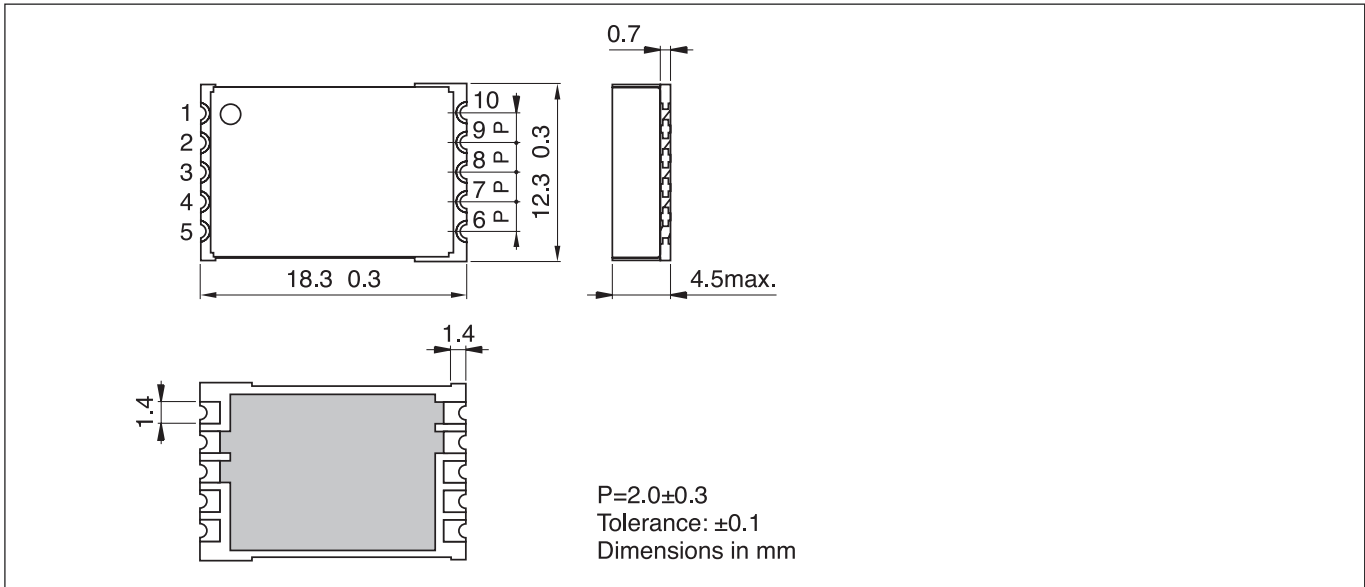

Outline Drawing CE-1050 Series

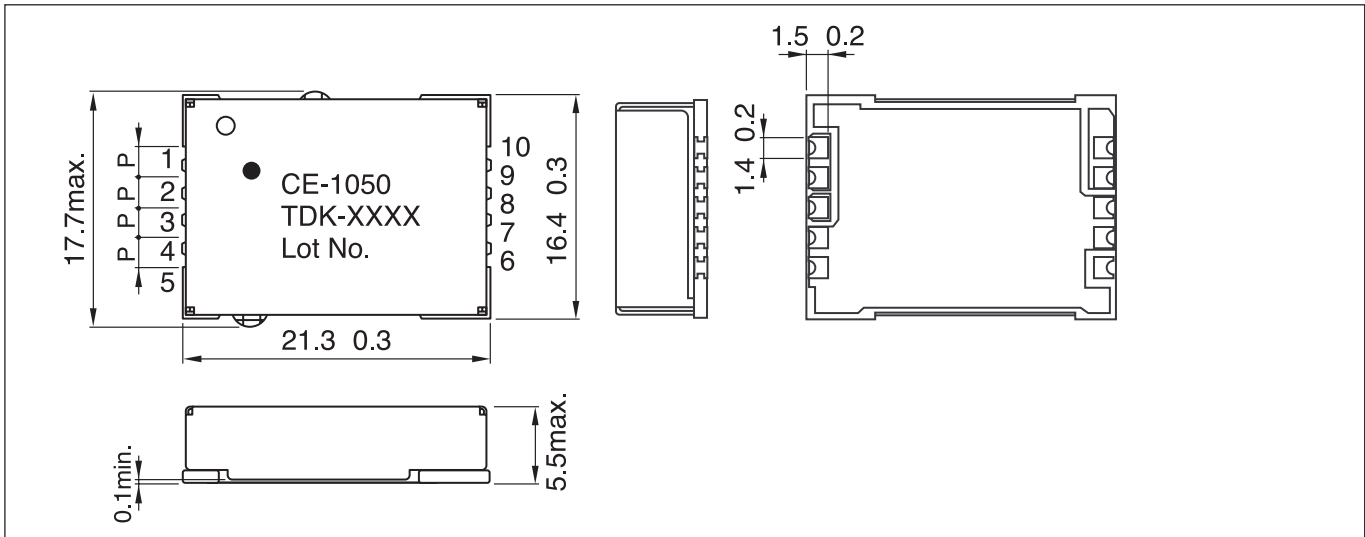

Pinout				
Pin	CE-1003	CE-1004	CE-1005	CE-1050
1	Vin	Vin	Vin	Vin
2	Vin	Vin	Vin	Vin
3	GND	GND	GND	GND
4	GND	GND	GND	GND
5	On / Off	On / Off	On/Off	On/Off
6	GND	GND	GND	GND
7	Vs-0	Vs-0	GND	GND
8	Vs-1	Vs-1	Vset	Vset
9	Vs-2	Vs-2	Vout	Vout
10	Vout	Vout	Vout	Vout

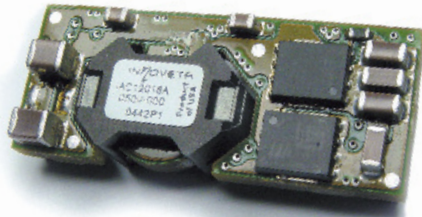

- Standard Industry Footprint (DOSA)
- 3.0-5.5V and 6.0-14.0V Input
- 0.8-5.0V Nominal Outputs
- Surface Mount
- Low 8.5mm Profile
- Non Isolated Output

iAA/iAC Series

15 to 16A

Point of Load Converter

iAA / iAC Features and Benefits

Features

- High operating efficiency (up to 95%)
- Constant switching frequency
- Starts with pre-biased output

Benefits

- Reduced system heating
- Easier system filtering
- Supports complex digital systems

Specifications

MODEL		iAA05015A008V	iAA05015A025V	iAA05015A033V	iAC12016A008V
ITEMS					
Nominal Output Voltage	VDC	0.75-3.63	2.5	3.3	0.8 - 5.0
Input Voltage Range	VDC	3.0-5.5 (2)	3.0-5.5 (2)	4.5-5.5	6.0 ⁽¹⁾ - 14
Input Current (max)	A		16		18
Output Voltage Tolerance	VDC	±3.3% Vo, set	2.413 - 2.588	3.19 - 3.41	-2.5 to +3.5% Vo, set
Ripple & Noise (max) (pk to pk) (3)	mV		75		100
Line Regulation (max)	mV		5		10
Load Regulation (max)	mV		10		15
Overload Protection	%	Inception - 175-235% of rated output; Short circuit - auto recovery			
Overvoltage Protection	-	N/A			
Remote Sense	-	Yes			
Remote On / Off	-	Positive or Negative Logic available, see Feature Set			
Sequencing	-	Not Available			See Feature Set
Temperature (operating)	°C	-40°C to +125°C			
Temperature (storage)	°C	-55°C to +125°C			
Humidity (operating)	-	20 - 95% RH Non condensing			
Humidity (storage)	-	Per IPC / JEDEC J-STD-020, for MSL-2 (<30C/60%RH) in original packaging			
Cooling	-	Convection or forced air			
Isolation Voltage	-	N/A			
Vibration (non operating)	-	5 to 50Hz @ 0.5g (4.9m/s ²), and 50 to 500Hz @ 1.5g (14.7m/s ²) per Bellcore TR-EOP-000063-5.4.4			
Shock	-	196.1m/s ²			
Safety Agency Approvals	-	UL60950 (US and Canada), VDE0805 (IEC60950), CB scheme (IEC60950)			
Weight (max)	g	12			
Size	mm	33 x 13.5 x 8.5			
Warranty	yrs	3			

Notes:

- (1) 8.3 - 14V when output is >3.63V
- (2) 4.5 - 5.5V when output is >3.0V
- (3) Measured across one 0.1µF ceramic capacitor and one 47µF ceramic capacitor; BW = 20MHz



Model Selector					
Model	Voltage Voltage (V)	Adjust Adjust (V)	Output Curr. (A)	Max. Output Power (W)	Efficiency at Full Load (%)
iAA05015A008V-000-R	0.75 - 3.63	0.75 - 3.63	15	49.5	94.5
iAA05015A008V-001-R	0.75 - 3.63	0.75 - 3.63	15	49.5	94.5
iAC12016A008V-000-R	0.8 - 5.0	0.8 - 5.0	16	80	94
iAC12016A008V-001-R	0.8 - 5.0	0.8 - 5.0	16	80	94
iAC12016A008V-002-R	0.8 - 5.0	0.8 - 5.0	16	80	94
iAC12016A008V-003-R	0.8 - 5.0	0.8 - 5.0	16	80	94

NB other configurations on request

Feature Set					
	Feature Set	Pos. Logic On / Off	Neg. Logic On / Off	Input Voltage	Sequencing
iAA	00	X			
	01*		X		
iAC	00	X		6.0 - 14.0	X
	01*		X	6.0 - 14.0	X
	02	X		6.0 - 14.0	
	03		X	6.0 - 14.0	

* Preferred feature set
Model Number Example: iAC12016A008V-001-R

Pinout			
PIN	iAA	Function	
		iAC(Seq)	iAC(No Seq)
1	Vin	On/Off	On/Off
2	Gnd	Vin	Vin
3	Vout	Seq	Gnd
4	Trim	Gnd	Vout
5	Sense	Vout	Trim
6	On/Off	Trim	Sense
7	-	Sense	-



Recommended Footprint (Top View) iAA/iAC (no sequence) Series

iAA/iAC
(no sequence)

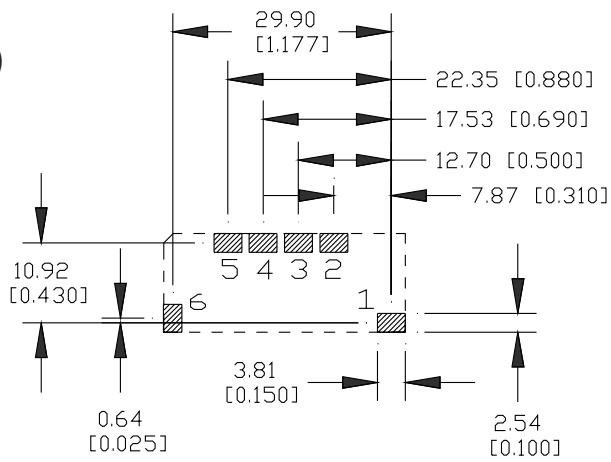

Recommended Footprint (Top View) iAC Series

iAC
(sequence)

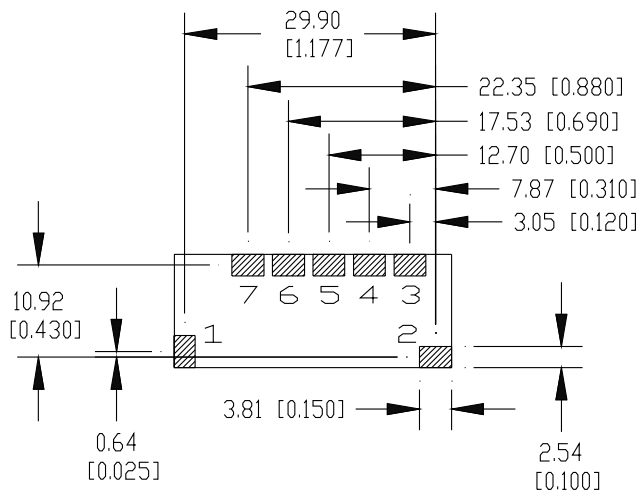



- Standard DOSA SIP Footprint
- 6.0-14VDC Input
- 0.8-5.5V Outputs
- Through Hole Mounting
- Low 13.97mm Profile
- Non Isolated Output

iAD Series

16A Point of Load Converters

iAD Features and Benefits

Features

- High operating efficiency (up to 94%)
- Constant switching frequency
- Starts with pre-biased output

Benefits

- Reduced system heating
- Easier system filtering
- Supports complex digital systems

Specifications

ITEMS	MODEL	iAD
Nominal Output Voltage	VDC	0.8 - 5.5V
Input Voltage Range	VDC	6 - 14V
Input Current (max)	A	18A
Output Voltage Tolerance	VDC	N/A
Ripple & Noise (max) (pk-pk)	mV	100
Line Regulation (max)	mV	15
Load Regulation (max)	mV	22
Overload Protection	%	Inception - 28A; Short circuit - auto recovery
Overvoltage Protection	-	N/A
Remote Sense	-	Yes
Remote On / Off	-	Positive or Negative Logic available, see Feature Set
Sequencing	-	Yes, see feature set
Temperature (operating)	°C	-40°C to +125°C
Temperature (storage)	°C	-55°C to +125°C
Humidity (operating)	-	20 - 95% RH Non condensing
Humidity (storage)	-	10 - 95% RH Non condensing
Cooling	-	Convection or forced air
Isolation Voltage	-	none
Vibration (non-operating)	-	5 to 50Hz@0.5g (4.9m/s ²), & 50 to 500Hz@1.5g (14.7m/s ²) per Bellcore TR-EOP-000063-5.4.4
Shock	-	196.1m/s ²
Safety Agency Certifications	-	UL60950 (US and Canada), VDE0805 (IEC60950), CB scheme (IEC60950)
Weight (max)	g	12
Size (LxWxH)	mm	50.8 x 7.9 x 14
Warranty	yrs	3



Model Selector

Model	Output Voltage (V)	Output Adjust (V)	Output Curr. (A)	Max. Output Power (W)	Efficiency at Full Load (%)
iAD12016A008V-000-R	0.80 - 5.5	0.80 - 5.5	16	80	94% at 5V
iAD12016A008V-001-R	0.80 - 5.5	0.80 - 5.5	16	80	94% at 5V

NB other configurations on request

Feature Set

Feat. Set	Pos. Logic On/Off	Neg. Logic On/Off	Input Voltage	Seq.	0.13" Pin	0.2" Pin
00*	X		6 - 14V	X	X	
01		X	6 - 14V	X	X	
02	X		6 - 14V		X	
03		X	6 - 14V		X	
04	X		6 - 14V	X		X
05		X	6 - 14V	X		X
06	X		6 - 14V			X
07		X	6 - 14V			X

* Preferred feature set

Model Number Example: iAD12016A008V-001-R

Pinout

PIN	Function	PIN	Function
1	Vout	6	GND
2	Vout	7	Vin
3	Sense	8	Vin
4	Vout	9	Sequencing
5	GND	10	Trim
		11	On / Off

Outline Drawing iAD Series

Mechanical Specifications:

Dimensions are in mm [in]. Unless otherwise specified tolerances are: x.x ±0.5 [0.02], x.xx ±0.25 [0.010]

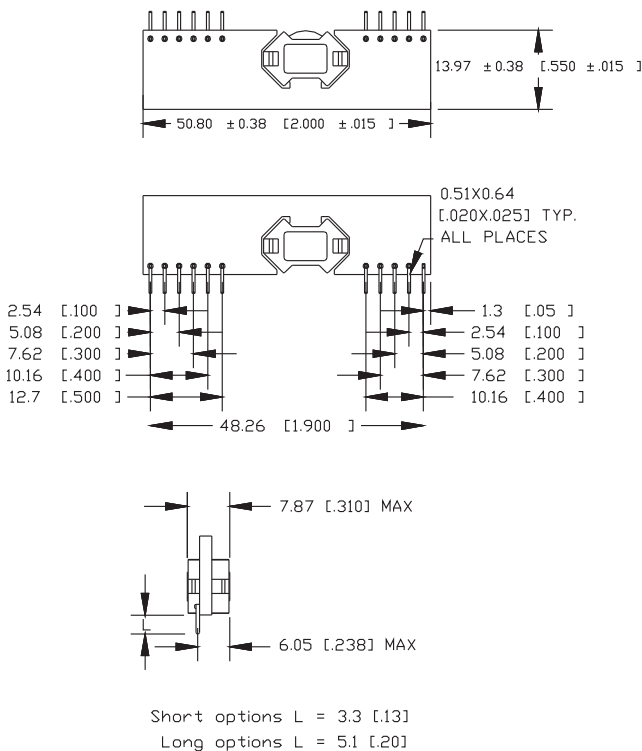

Recommended Hole Pattern (Top View)

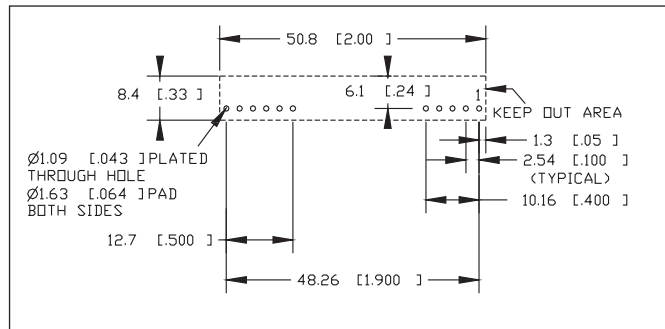

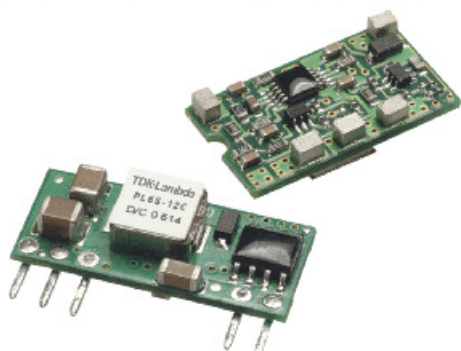

PL5 Series

5A Non-Isolated
DC-DC Converters

- Industry Standard Package and Pin Out
- DOSA Compatible Models
- Low Voltage Outputs to 0.75V
- Pin and SMT Versions
- Output Voltage Adjustment
- Remote On/Off

Key Market Segments & Applications

- Telecommunications
- Data Communications
- Networking Equipment
- Test Equipment
- Industrial Electronics
- Distributed Power Architecture

PL5 Features and Benefits

Features

- High Efficiency up to 94%
- Wide Output Voltage Adjustment Range
- SMT or Through Hole Packages
- Industry Standard Pin Out

Benefits

- Reduces Input Current Draw
- Stock One Part for all Voltages
- Multiple Mounting Methods
- Second Sourcing

Specifications

MODEL		PL5S-05C	PL5SMS-05C	PL5S-12C	PL5SMS-12C
ITEMS					
Output Voltage Range	(2) VDC	0.75 - 3.3VDC		0.75 - 5.0VDC	
Output Current	A	5 Amps			
Output Voltage Accuracy	%	±1.5%			
Turn on/off Threshold (typ)	VDC	On: 2.0V, Off: 1.9V		On: 8.0V, Off: 7.9V	
Ripple & Noise (Typ)	(1) mV	20mV rms, 50mV pk-pkVo=5VDC, 45mV rms, 75mV pk-pk			
Line Regulation (Typ)	%	± 0.4% (Vo=3.3V)		± 0.2% (Vo=3.3V)	
Load Regulation (Typ)	%	± 0.5% (Vo=3.3V)			
Capacitive Load (max)	µF	3000µF			
Transient Response	-	<200µs settling time for 25% load change			
Overcurrent Protection	-	Continuous			
Overvoltage Protection	-	N/A			
Over Temp. Protection	°C	120°C typ.			
Remote Sense	-	N/A			
Remote On / Off	-	On: Vin or open circuit; Off: <0.4VDC			
Operating Temperature	°C	-40°C to +85°C			
Operating Humidity	%	20 - 95% Non condensing			
Storage Temperature	°C	-55°C to +125°C			
Storage Humidity	%	10 - 95% Non condensing			
Cooling	-	Convection, or forced air			
Vibration (non operating)	-	10 - 500 -10 Hz, amplitude 1.524mm, X, Y, Z 6 minutes each			
Shock	-	half sine wave, 40g, 11ms, 3 times each axis, +X, -X, +Y, -Y, +Z, -Z			
Safety Agency Approvals	-	UL/C-UL60950			
Switching Frequency	kHz	300kHz			
Weight (Typ)	g	2.1	2.4	2.1	2.4
Size (W x L x H)	-	See outline drawing			
Warranty	yrs	2			

Note: See Installation Manual for full details, test methods of parameters and application notes

(1) The output noise is measured with a 10µF tantalum cap and 1µF ceramic cap across output (2) See application notes for Trim equations and tables



Model Selector						
Model	Input Voltage (VDC)	Output Voltage (VDC)	Output Curr. (A)	Input Current* No Load (mA)	Input Current* Full Load (mA)	Eff. (%)
PL5S-05C and PL5SMS-05C	3.0 - 5.5	0.75	5	25	949	79
	3.0 - 5.5	1.2	5	30	1412	85
	3.0 - 5.5	1.5	5	30	1724	87
	3.0 - 5.5	1.8	5	35	2022	89
	3.0 - 5.5	2	5	35	2222	90
	3.0 - 5.5	2.5	5	35	2217	92
	4.5 - 5.5	3.3	5	35	3511	94
PL5S-12C and PL5SMS-12C	8.3 - 14	0.75	5	20	428	73
	8.3 - 14	1.2	5	25	625	80
	8.3 - 14	1.5	5	25	762	82
	8.3 - 14	1.8	5	30	893	84
	8.3 - 14	2	5	30	980	85
	8.3 - 14	2.5	5	35	1197	87
	8.3 - 14	3.3	5	45	1545	89
	8.3 - 14	5.0	5	50	2264	92

PL5S - SIL 5 pins
PL5SMS - Surface Mount

* At nominal input voltage (5V or 12V depending on model)

Remote On /Off Option	
Suffix	Function
Blank	On: Vin or open circuit; Off<0.4VDC
N	On: open circuit or <0.4VDC; Off: >2.8VDC to Vin

Pinout			
PIN	Function	PIN	Function
1	+ Output	2	Trim
3	Common	4	+V Input
5	On/Off		

Outline Drawing PL5S Series

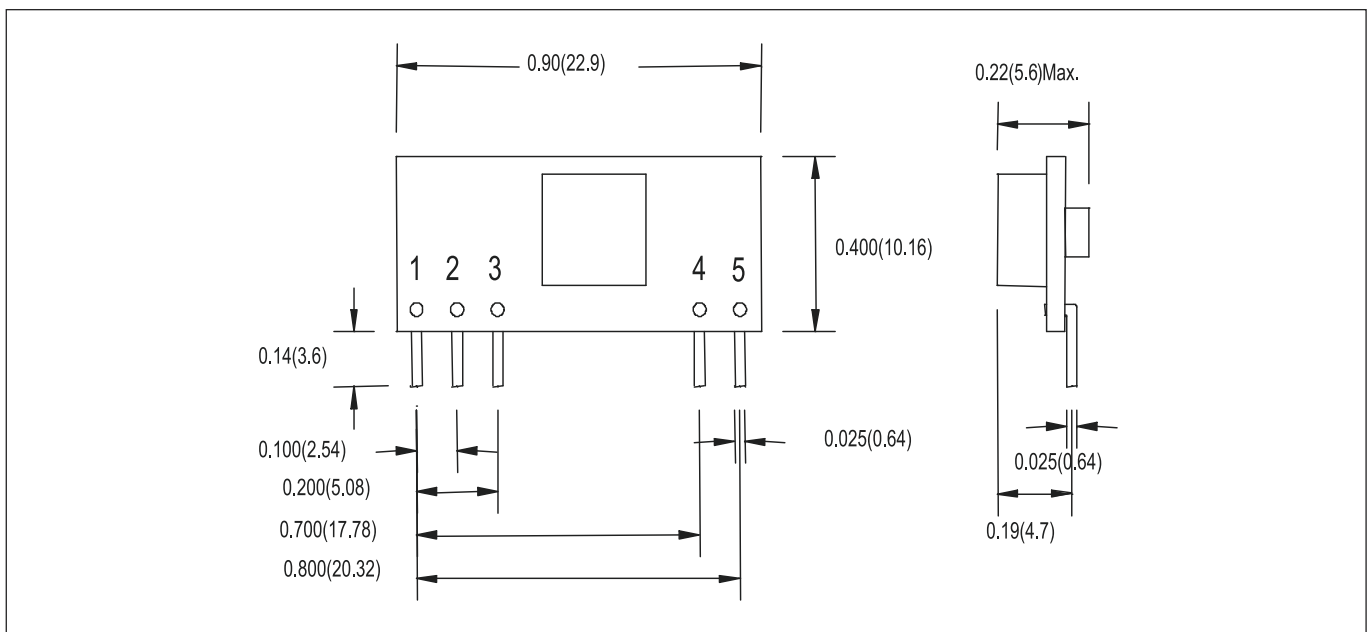



Outline Drawing PL5SMS Series

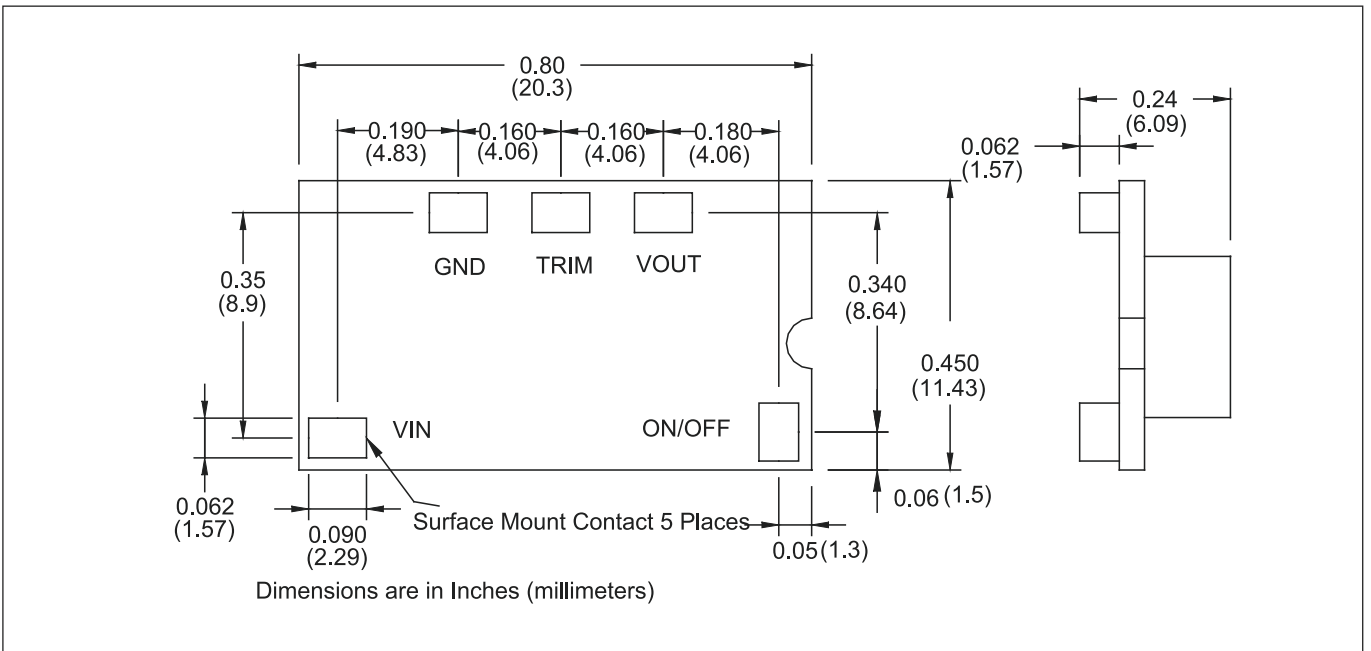

Derating Curve

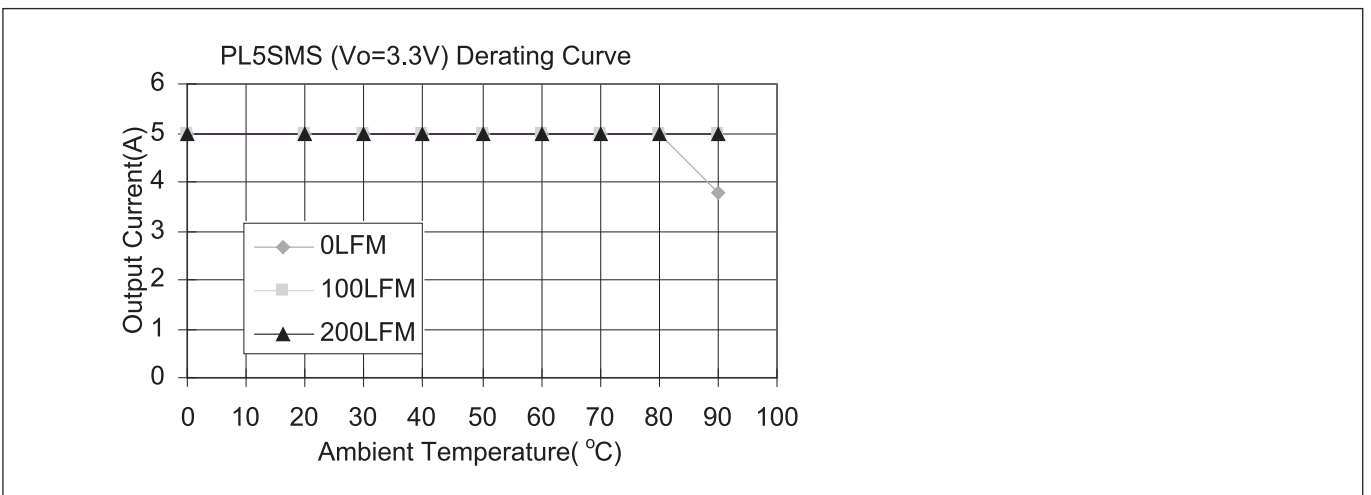
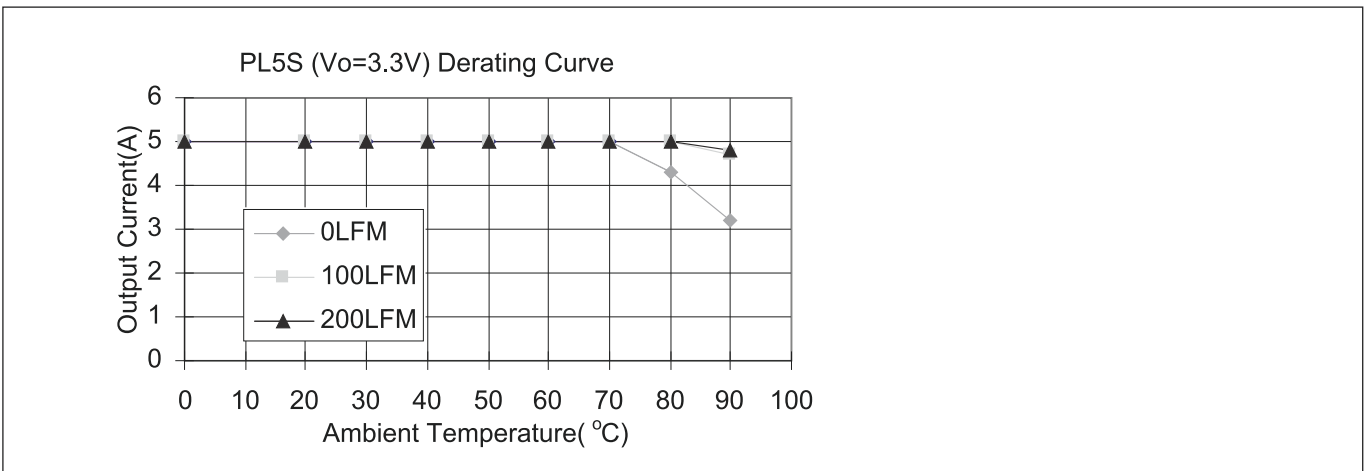

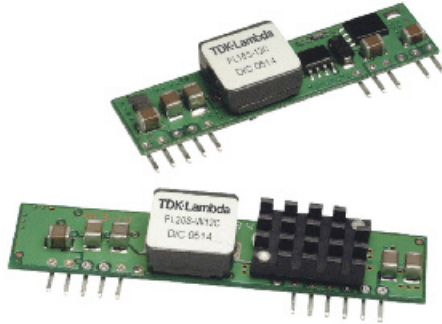

- Industry Standard Package and Pin Out
- DOSA Compatible Models
- Low Voltage Outputs to 0.75V
- Wide Input Range 6 to 14V ('W' Models)
- Output Voltage Adjustment
- Remote On/Off and Sequencing ('W' Models)

Key Market Segments & Applications

- Distributed Power Architecture
- Telecommunications
- Data Communications
- Networking Equipment
- Test Equipment
- Industrial Electronics

PL10-20S Series

10-20A Non-Isolated
DC-DC Converters

PL10-20S Features and Benefits

Features

- High Efficiency up to 95%
- Wide Output Voltage Adjustment Range
- Through Hole Packages
- Industry Standard Pin Out

Benefits

- Reduces Input Current Draw
- Stock One Part for all Voltages
- Less PCB Space Used
- Second Sourcing

Specifications

MODEL		PL10S-W12C	PL10S-12	PL16S-12C	PL16S-W12C	PL20S-W12C
ITEMS						
Output Voltage Range	(2) VDC	0.75 - 5.0VDC				
Output Current	A	10		16		20
Output Voltage Accuracy	%	±1.5% max.				
Turn on/off Threshold (typ)	VDC	On: 5.0V, Off: 4.0V	On: 8.0V, Off: 7.7V		On: 5.0V, Off: 4.0V	
Ripple & Noise (Typ)	(2) mV	20mV rms, 75mV pk-pk		30mV rms, 75mV pk-pk		
Line Regulation (Typ)	%	± 0.2% (Vo=3.3V)				
Load Regulation (Typ)	%	±0.5% (Vo=3.3V)				
Capacitive Load (max)	µF	8000µF				
Transient Response	-	<200µs settling time for 25% load change				
Overcurrent Protection	-	Continuous				
Overvoltage Protection	-	N/A				
Over Temp. Protection	°C	+120°C typ.		+130°C typ.		
Remote Sense	-	Yes				
Remote On / Off	-	On: Vin or open circuit; Off: <0.4VDC				
Power Good Signal (logic high)	%	Optional	N/A		Optional	
Operating Temperature	°C	-40°C to +85°C				
Operating Humidity	%	20 - 95% Non condensing				
Storage Temperature	°C	-55°C to +125°C				
Storage Humidity	-	10 - 95% Non condensing				
Cooling	-	Convection, or forced air				
Vibration (non operating)	-	10 - 500 - 10Hz, amplitude 1.524mm, X, Y, Z 6 minutes each				
Shock	-	Half sine wave, 40g, 11ms, 3 times each axis, +X, -X, +Y, -Y, +Z, -Z				
Safety Agency Approvals	-	UL/C-UL60950				
Sequencing/Tracking	-	Yes	-		Yes	
Switching Frequency	kHz	300kHz				
Weight (Typ)	g	8.0	10.0	8.0	8.5	10.1
Size (WxHxD)	-	See outline drawing				
Warranty	yrs	2				

Note: See Installation Manual for full details, test methods of parameters and application notes

(1) The output noise is measured with a 10µF tantalum cap and 1µF ceramic cap across output (2) See application notes for Trim equations and tables



Model Selector						
Model	Input Voltage (VDC)	Output Voltage (VDC)	Output Curr. (A)	No Load (mA)	Full Load (mA)	Eff. (%)
PL10S-W12C	6.0 - 14	0.75	10	40	762	82
	6.0 - 14	1.2	10	40	1149	87
	6.0 - 14	1.5	10	50	1404	89
	6.0 - 14	1.8	10	40	1666	90
	6.0 - 14	2.0	10	60	1832	91
	6.0 - 14	2.5	10	65	2264	92
	6.0 - 14	3.3	10	75	2956	93
	6.5 - 14	5.0	10	95	4386	95
PL10S-12-1V0	9.0 - 14	1.0	10	50	992	84
PL10S-12-1V2	9.0 - 14	1.2	10	50	1163	86
PL10S-12-1V5	9.0 - 14	1.5	10	50	1404	89
PL10S-12-1V8	9.0 - 14	1.8	10	60	1666	90
PL10S-12-2V0	9.0 - 14	2.0	10	60	1832	91
PL10S-12-2V5	9.0 - 14	2.5	10	70	2264	92
PL10S-12-3V3	9.0 - 14	3.3	10	70	2956	93
PL10S-12-5V0	9.0 - 14	5.0	10	70	4385	95
PL10S-12-C	8.3 - 14	0.75-5.0	10	70	4385	95
PL16S-12C	9.0 - 14	0.75	16	40	1299	77
	9.0 - 14	1.2	16	50	1928	83
	9.0 - 14	1.5	16	50	2326	86
	9.0 - 14	1.8	16	60	2727	88
	9.0 - 14	2.0	16	60	2996	89
	9.0 - 14	2.5	16	65	3704	90
	9.0 - 14	3.3	16	75	4783	92
	9.0 - 14	5.0	16	75	7092	94
PL16S-W12C	6.0 - 14	0.75	16	40	1250	80
	6.0 - 14	1.2	16	40	1882	85
	6.0 - 14	1.5	16	50	2273	88
	6.0 - 14	1.8	16	60	2697	89
	6.0 - 14	2.0	16	60	2963	90
	6.0 - 14	2.5	16	65	3663	91
	6.0 - 14	3.3	16	75	4731	93
	6.5 - 14	5.0	16	95	7092	94
PL20S-W12C	6.0 - 14	0.75	20	40	1603	78
	6.0 - 14	1.2	20	50	2381	84
	6.0 - 14	1.5	20	50	2874	87
	6.0 - 14	1.8	20	50	3409	88
	6.0 - 14	2.0	20	60	3745	89
	6.0 - 14	2.5	20	65	4630	90
	6.0 - 14	3.3	20	75	5978	92
	6.5 - 14	5.0	20	95	8865	94

Pinout			
PL10S-W, 16S-W, 20S-W		PL16S-12C	
PIN	Function	PIN	Function
1	+Output	1	+Output
2	+Output	2	+Output
3	+Sense	3	+Sense
4	+Output	4	+Output
5	Common	5	Common
6	No Pin/PGood option	6	Common
7	Common	7	+V Input
8	+V Input	8	+V Input
9	+V Input	9	No Pin
10	Sequencing	10	Trim
11	Trim	11	On/Off Control
12	On/Off Control		

Options	
Remote On / Off Option	
Blank	On: Vin or open circuit; Off: <0.4VDC
N	On: open circuit or <0.4VDC; Off: >2.8VDC to Vin
Power Good Option	
P	(available on W12C models)



Outline Drawing PL16S-12C Series

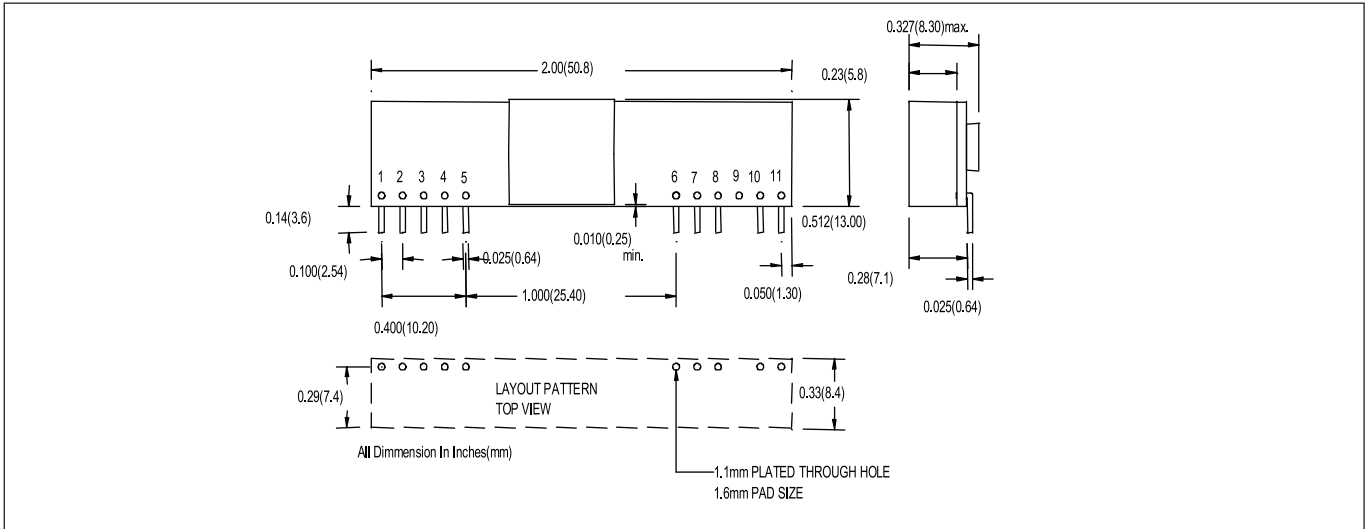

Outline Drawing PL10S-W12C & PL16S-W12C Series

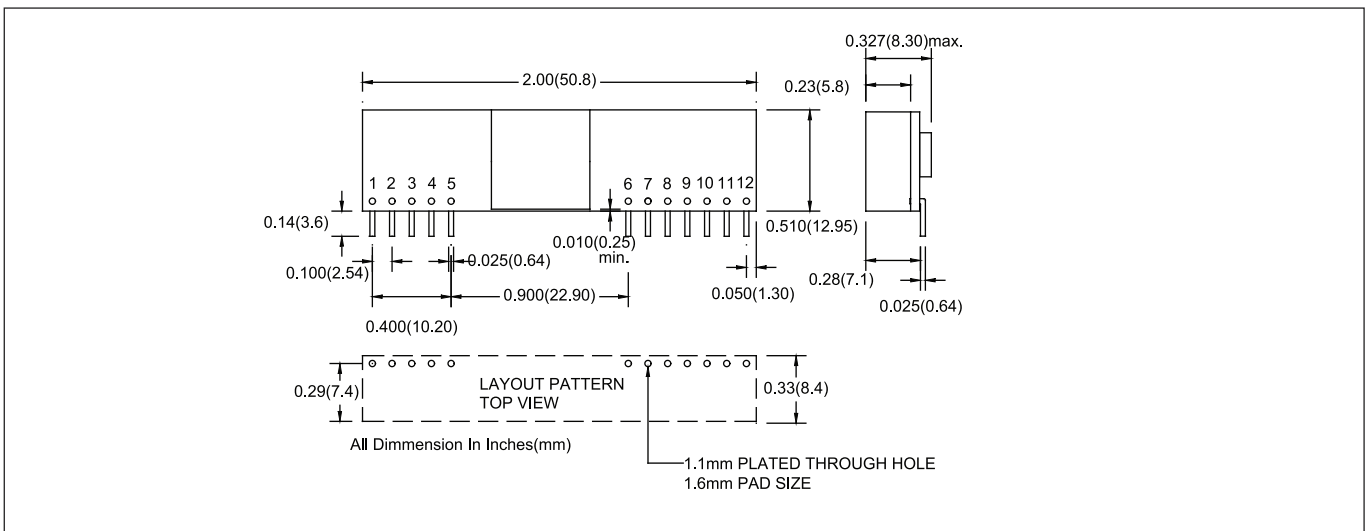

Outline Drawing PL20S-W12C Series

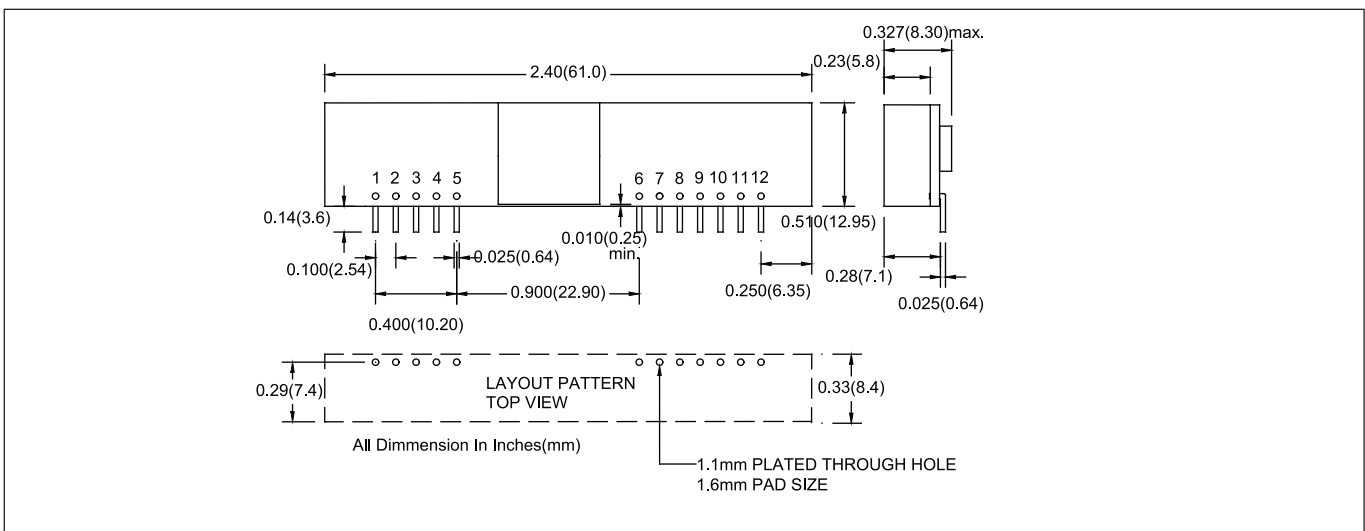



PL10-20SMS Series

10-20A Surface Mount
Non-Isolated DC-DC Converters

- Industry Standard Package and Footprint
- DOSA Compatible Models
- Low Voltage Outputs to 0.75V
- Wide Input Range 6 to 14V (on 'W' models)
- Output Voltage Adjustment
- Remote On/Off and Sequencing ('W' models)

Key Market Segments & Applications

- Telecommunications
- Data Communications
- Networking Equipment
- Test Equipment
- Industrial Electronics
- Distributed Power Architecture

PL10-20SMS Features and Benefits

Features

- High Efficiency up to 95%
- Wide Output Voltage Adjustment Range
- SMT Packages
- Industry Standard Pin Out

Benefits

- Reduces Input Current Draw
- Stock One Part for all Voltages
- Low Assembly Cost
- Second Sourcing

Specifications

ITEMS	MODELS		PL10SMS-12C	PL10SMS-W12C	PL15SMS05C	PL16SMS-12C	PL16SMS-W12C	PL20SMS-W12C
	(2)	VDC	0.75-5.0		0.75-3.3	0.75-5.0		
Output Voltage Range	(2)	VDC	0.75-5.0		0.75-3.3	0.75-5.0		
Output Current		A	10		15	16		20
Output Voltage Accuracy		%	±1.5%					
Turn On/Off Threshold	ON	VDC	8.0V	5.0V	2.8V	8.0V	5.0V	5.0V
	OFF	VDC	7.7V	4.0V	2.7V	7.7V	4.0V	4.0V
Ripple & Noise (Typ)	(1)	mV	V		30mV rms, 75mV pk-pk			
Line Regulation (Typ)		%	±0.2% (Vo=3.3V)					
Load Regulation (Typ)		%	±0.5% (Vo=3.3V)					
Capacitive Load (max)		µF	8000µF		10000µF		8000µF	
Transient Response		-	<200µs settling time for 25% load change					
Overcurrent Protection		-	Continuous					
Overvoltage Protection		-	N/A					
Over Temp. Protection		°C	+120°C typ.	+130°C typ.	+120°C typ.	+130°C typ.		
Remote Sense		-	Yes					
Remote On / Off		-	On: Vin or open circuit; Off: <0.4VDC					
Sequencing/Tracking		-	-	Yes	-	-	Yes	Yes
Power Good Signal (logic high)		-	-	Optional	-	-	Optional	
Operating Temperature		°C	-40°C to +85°C					
Operating Humidity		%	20 - 95% Non condensing					
Storage Temperature		°C	-55°C to +125°C					
Storage Humidity		%	10 - 95% Non condensing					
Cooling		-	Convection, or forced air					
Vibration (non operating)		-	10 - 500 - 10Hz, amplitude 1.524mm, X, Y, Z 6 minutes each					
Shock		-	Half sine wave, 40g, 11ms, 3 times each axis, +X, -X, +Y, -Y, +Z, -Z axis					
Safety Agency Approvals		-	UL/C-UL60950					
Switching Frequency		kHz	300kHz					
Weight (Typ)		g	6.5	7.7	6.5	6.8	7.7	10.7
Size (WxHxD)		-	See outline drawing					
Warranty		yrs	2					

Note: See Installation Manual for full details, test methods of parameters and application notes

(1) The output noise is measured with a 10µF tantalum cap and 1µF ceramic cap across output. (2) See Application Notes for Trim equations and tables.



Model Selector						
Model	Input Voltage (VDC)	Output Voltage (VDC)	Output Curr. (A)	No Load (mA)	Full Load (mA)	Eff. (%)
PL10SMS-12C	8.3 - 14	0.75	10	50	762	82
	8.3 - 14	1.2	10	50	1163	86
	8.3 - 14	1.5	10	50	1404	89
	8.3 - 14	1.8	10	60	1666	90
	8.3 - 14	2.0	10	60	1832	91
	8.3 - 14	2.5	10	60	2264	92
	8.3 - 14	3.3	10	70	2956	93
	8.3 - 14	5.0	10	70	4385	94
PL10SMS-W12C	6.0 - 14	0.75	10	40	762	82
	6.0 - 14	1.2	10	40	1149	87
	6.0 - 14	1.5	10	50	1404	89
	6.0 - 14	1.8	10	40	1666	90
	6.0 - 14	2.0	10	60	1832	91
	6.0 - 14	2.5	10	65	2264	92
	6.0 - 14	3.3	10	75	2956	93
	6.5 - 14	5.0	10	95	4386	95
PL15SMS-05C	3.0-5.5	0.75	15	60	3658	82
	3.0-5.5	1.2	15	60	4286	84
	3.0-5.5	1.5	15	60	5172	87
	3.0-5.5	1.8	15	70	6136	88
	3.0-5.5	2.0	15	70	6742	89
	3.0-5.5	2.5	15	70	8152	92
	4.5 - 5.5	3.3	15	70	10532	94
	9.0 - 14	0.75	16	40	1299	77
PL16SMS-12C	9.0 - 14	1.2	16	50	1928	83
	9.0 - 14	1.5	16	50	2326	86
	9.0 - 14	1.8	16	60	2727	88
	9.0 - 14	2.0	16	60	2996	89
	9.0 - 14	2.5	16	65	3704	90
	9.0 - 14	3.3	16	75	4783	92
	9.0 - 14	5.0	16	75	7092	94
	6.0 - 14	0.75	16	40	1250	80
PL16SMS-W12C	6.0 - 14	1.2	16	40	1882	85
	6.0 - 14	1.5	16	50	2273	88
	6.0 - 14	1.8	16	60	2697	89
	6.0 - 14	2.0	16	60	2963	90
	6.0 - 14	2.5	16	65	3663	91
	6.0 - 14	3.3	16	75	4731	93
	6.5 - 14	5.0	16	95	7092	94
	6.0 - 14	0.75	20	40	1603	78
PL20SMS-W12C	6.0 - 14	1.2	20	50	2381	84
	6.0 - 14	1.5	20	50	2874	87
	6.0 - 14	1.8	20	50	3409	88
	6.0 - 14	2.0	20	60	3745	89
	6.0 - 14	2.5	20	65	4630	90
	6.0 - 14	3.3	20	75	5978	92
	6.5 - 14	5.0	20	95	8865	94

Options	
Remote On / Off Option	
Blank	On: Vin or open circuit; Off: <0.4VDC
N	On: open circuit or <0.4VDC; Off: >2.8VDC to Vin
Power Good Option	
P	(available on W12C models)



Outline Drawing PL10SMS-12C, PL15SMS-05C & PL16SMS-12C Series

BOTTOM VIEW OF BOARD

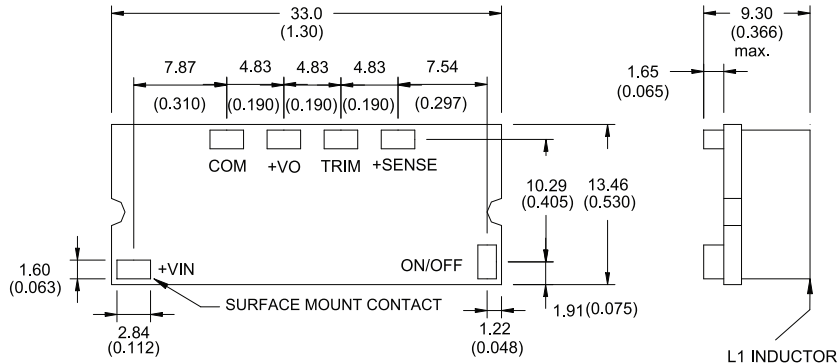

Outline Drawing PL10SMS-W12C & PL16SMS-W12C Series

BOTTOM VIEW OF BOARD

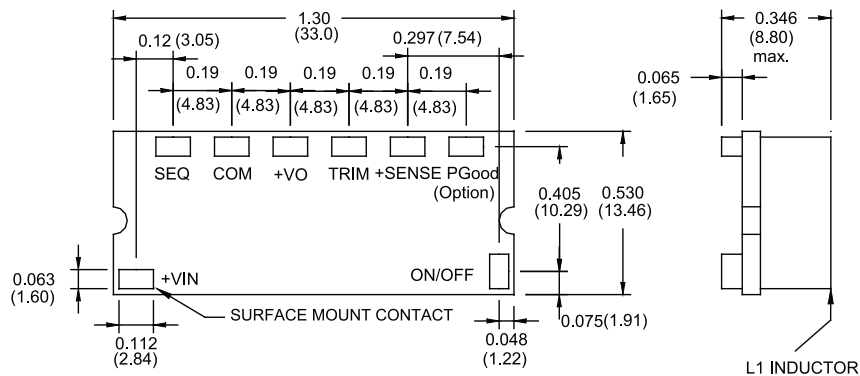

Outline Drawing PL20SMS-W12C Series

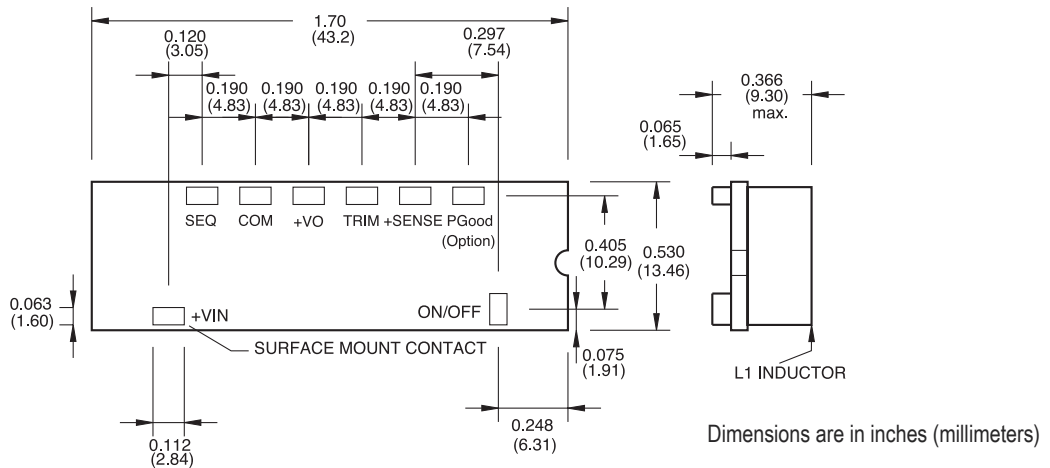



MC12 / MZ12 series 1-phase

New standard, complies with RoHS directive led by lead free. Meets every aspect of industrial requirement for EMC solution. High cost performance, terminal connection type Noise Filter. Available with low leakage and DIN-Rail option.

MC13 series 3-phase

Compact & clean. Small to mount on FA / Robot control panel. Environmentally friendly and lead free. Available for screw mounting and DIN-Rail mounting.

Line Filters

Specifications			
Series	MC12	MZ12	MC13
Rated voltage	250 V	250 V	500 V AC 3-phase 50/60 Hz
Rated current	6 A – 30 A	6 A – 30 A	6 A – 30 A
Test voltage	terminal-case: 2500 V AC (20 mA)	terminal-case: 2500 V AC (20 mA)	terminal-case: 2000 V AC (100 mA)
Leakage current standard or low leakage type	1 mA max. at 250 V AC or 10 μ A max. at 250 V AC	1 mA max. at 250 V AC or 10 μ A max. at 250 V AC	5 mA max. at 500 V AC
Dimensions (DIN-type)	97 (108) x 34.5 x 60 mm	97 (108) x 34.5 x 60 mm	145 (136) x 52 x 63 mm
Weight	300 g	300 g	600 g

TDK-Lambda offers a complete range of line filters to provide optimum attenuation of conducted noise. Further series with higher current capability and designs for 48 V DC are available on request.

For complete range please visit www.emea.tdk-lambda.com/filters



Innovating Reliable Power

TDK-Lambda EMEA offer customers a unique proposition for custom power solutions

Innovating

Our position as a leading global supplier of standard and configurable power products for over 60 years means we can capitalise on our extensive Advanced Technology research and over 700 patents to provide innovative leading edge custom power solutions with high power density, high efficiency and digital control.

Reliable Power

Our key focus is not only ensuring the long term reliability of our products but also being reliable in all aspects of our business relationships with you. Our systems and processes are in accordance with ISO9001 and ISO14001 to ensure consistent, environmentally responsible, high quality products and services. TDK-Lambda custom products utilise field proven topologies, components and validation / test methodologies derived from the millions of TDK-Lambda products in use worldwide to give you a fast response, low risk solution.

The best solution

TDK-Lambda custom power solutions include full bespoke designs, modified standards and 'brick on board' products. Our expertise is vast, covering 0.6V to 50kV, 1W to 50kW ACDC and DCDC. As well as satisfying your technical requirements we will always offer you the best all round solution taking into account cost, time to market and reliability.

Applications

We recognise that each customer's application is unique in some way. TDK-Lambda's specialist knowledge of the key attributes of many different applications is gained from many years experience working with loyal customers for both custom and standard power supply requirements

Key market segments covered include:

- Factory Automation
- Process Control
- Test and Measurement
- Medical and Laboratory
- Broadcast
- Communications
- LED Lighting and Signage
- Defence and Aerospace
- Computer and Office Automation
- Semiconductor Manufacture
- Point of Sale and Vending
- Renewable Energies





Product Design Process

Technical Proposal

- Detailed proposal based on Customer Specification
- Supported by Spice Circuit Simulation
- Mechanical concept in 3D CAD

Standard Field Proven Technologies

- Fly-back, forward, boost
- Resonant and multi resonant
- Synchronous rectification
- Digital control and/or monitoring
- High efficiency, low audible noise

Component Selection

- Cost optimisation by use of standard component set
- In-house component evaluation laboratory
- All components qualified to TDK-Lambda group standard
- Components selected to meet TDK-Lambda de-rating criteria
- RoHS validation laboratory

Design Verification Testing

- Electrical performance across entire operating environment
- Thermal performance across entire operating environment
- EMC compliance, in-house conducted and 10M OATS
- Immunity – Surge, burst, ESD, ring-wave
- Mechanical – Sinusoidal vibration, shock
- HALT, high altitude simulation, TST, humidity
- Ingress protection (IP) testing

Regulatory Approvals

- In-house Approved Safety Test Laboratory
- IECCE SMT program under UL for IEC/EN60950-1, IEC/EN60601-1, IEC/EN61010-1 and CB
- CTDTP for UL/CSA60950-1, UL/CSA60601-1, UL/CSA61010-1
- CE Certification
- Other approvals by request

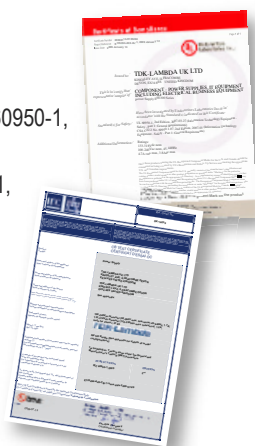

Acronyms

- CAD: Computer aided design
- TST: Thermal shock test
- OATS: Open area test site
- SMT: Supervised manufacturer's testing program
- ESD: Electrostatic discharge
- CTDTP: Client test data program
- HALT: Highly accelerated life test
- IECEE: International Electrotechnical Commission for Electrical Equipment

www.emea.tdk-lambda.com



Whilst TDK-Lambda tries to ensure that the information contained in this Catalogue is accurate it does not accept liability for any inaccuracies
In exceptional circumstances TDK-Lambda reserves the right, without notice or liability, to withdraw products or alter specifications at any time

Printed on paper sourced from certified forests and other responsible sources using biodegradable vegetable and soya based inks
Laminated with biodegradable *Clarifoil* cellulose film

Printed by *Toptown Printers Ltd* +44 (0)1271 371271





Innovating Reliable Power

Please contact your local sales office to find the best solution for your application



TDK-Lambda France SAS

ZAC des Delaches
BP 1077-Gometz-le-Chatel
91940 Les Ulis
France
Tel: +33 1 60 12 71 65
Fax: +33 1 60 12 71 66
france@fr.tdk-lambda.com
www.fr.tdk-lambda.com



Italy Sales Office
Via dei Lavoratori 128/130
20092 Cinisello Balsamo (MI)
Italy
Tel: +39 02 61 29 38 63
Fax: +39 02 61 29 09 00
info.italia@it.tdk-lambda.com
www.it.tdk-lambda.com



TDK-Lambda Germany GmbH

Karl-Bold-Strasse 40
77855 Achern
Germany
Tel: +49 7841 666 0
Fax: +49 7841 5000
info.germany@de.tdk-lambda.com
www.de.tdk-lambda.com



Austria Sales Office
Aredstrasse 22
2544 Leobersdorf
Austria
Tel: +43 2256 655 84
Fax: +43 2256 645 12
info.germany@de.tdk-lambda.com
www.de.tdk-lambda.com



TDK-Lambda UK Ltd.

Kingsley Avenue
Ilfracombe
Devon EX34 8ES
United Kingdom
Tel: +44 (0) 12 71 85 66 66
Fax: +44 (0) 12 71 86 48 94
powersolutions@uk.tdk-lambda.com
www.uk.tdk-lambda.com



Nemic Lambda Ltd.

Kibbutz
Givat Hashlosha 48800
Israel
Tel: +9 723 902 4333
Fax: +9 723 902 4777
info@nemic.co.il
www.nemic.co.il



Russia

Technical Support:
St Petersburg
Tel: +7 (812) 6580463
Sales:
Moscow
Tel: +7 (499) 7557732
info@tdk-lambda.ru
www.tdk-lambda.ru



TDK-Lambda EMEA
www.emea.tdk-lambda.com