



VIGOR DRIVE

RV SERIES

High Precision Gear Reducers

For precision mechanical control in robot,
machine tool and factory automation equipment.

TECHNICAL DATA

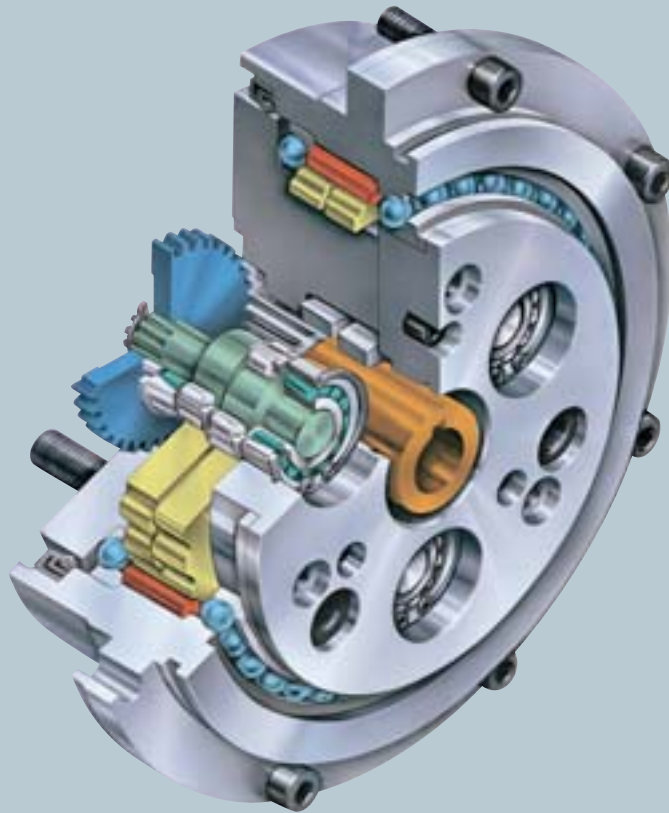

Nabtesco

PRECISION REACHES A NEW LEVEL

VIGOR DRIVE

The RV Series is a family of planocentric reduction gear mechanisms designed for precise motion control. The mechanisms incorporate a large number of simultaneously engaged gear teeth, and have compact, lightweight and highly rigid construction that is strong against overloading. Furthermore, minimal backlash, rotary vibration and inertia assure rapid acceleration, smooth motion and extremely accurate positioning.

The RV Series reduction gears are ideally suited for precision mechanical control in factory robots, machine tools, and assembly and conveying equipment where precise positioning, stiffness and shock-load capability are demanded.

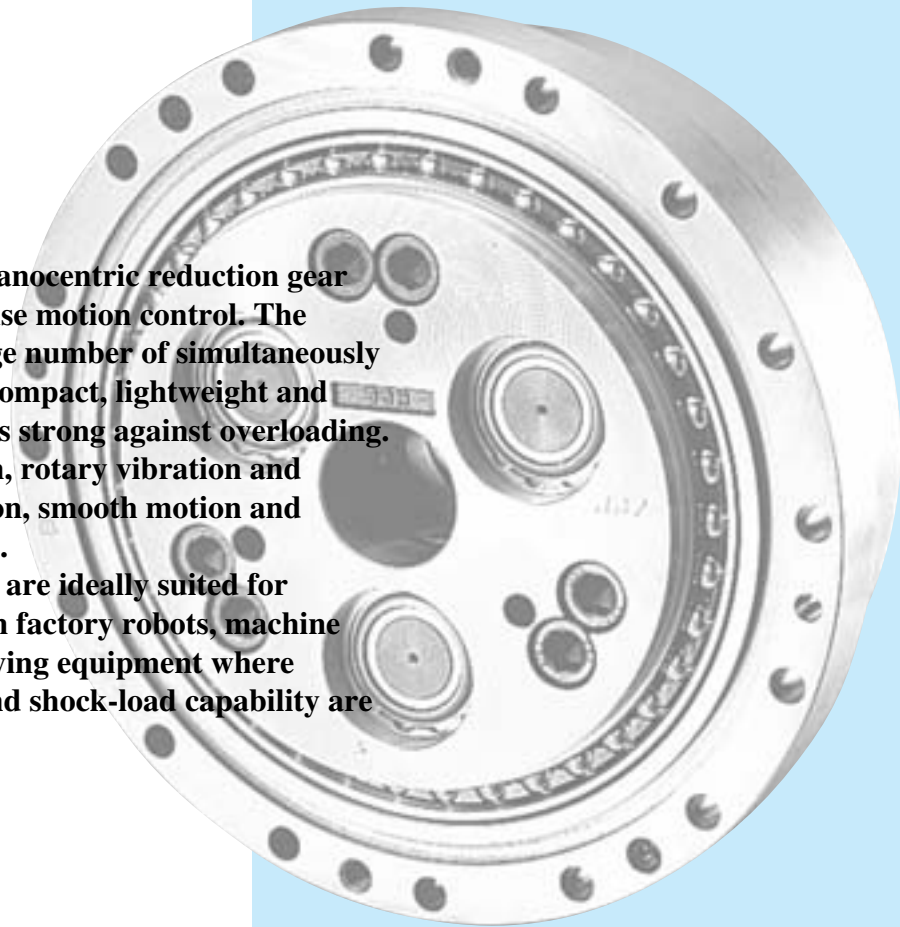

Reducer For High Precision Control

Technical data - Rigidly built reduction gear for high precision control

C O N T E N T S

1	Ordering Information	1
2	Application Examples	3
3	RV-E Series	
1	Features and Benefits	8
2	Construction and Operation Principle	9
3	Rotary Direction and Speed Ratio	10
4	Ratings Table	11
5	RV-E Selection	13
5-1	Selection flow chart	13
5-2	Strength and Service Life	15
5-2-1	Allowable torque during acceleration or deceleration	15
5-2-2	Momentary maximum allowable torque	15
5-2-3	Rated Service Life	15
5-3	Capacity of Main Bearing	16
5-3-1	Moment rigidity	16
5-3-2	Allowable moment	16
5-3-3	Momentary maximum Allowable moment	17
6	Performance Characteristics	18
6-1	Rigidity (Torsional rigidity and lost motion) and Backlash	18
6-1-1	Calculation of torsion (an example)	18
6-2	Vibration	19
6-3	Angular transmission accuracy	19
6-4	No-load running torque	20
6-5	Backdriving torque	20
6-6	Low-temperature characteristics	21
6-7	Efficiency charts	22
7	Installation and Assembly	23
7-1	Assembly accuracy	23
7-2	Installation procedure	23
7-2-1	Bolt clamping output shaft type	23
7-2-2	Pin/bolt clamping output shaft type	24
7-3	Bolt tightening torque and allowable transmission torque	25
7-4	Installation of input gear	26
7-4-1	Precautions for input gear installation of RV-6E, 20E and 40E input gears	27
7-4-2	Pass-through capacity of input gear	27
7-4-3	An example of installation for the reduction gear with lower speed ratio	28
7-5	Lubrication	28
7-5-1	Grease lubrication	28
7-6	Warranty	30
8	External Dimensions	31
4	RV-C Series	
1	Features and Benefits	54
2	Construction and Operation Principle	55
3	Rotary Direction and Speed Ratio	56
4	Ratings Table	57
5	RV-C Selection	59
5-1	Selection flow chart	59
5-2	Strength and Service Life	61
5-2-1	Allowable torque during acceleration or deceleration	61
5-2-2	Momentary maximum allowable torque	61
5-2-3	Rated Service Life	61
5-3	Capacity of Main Bearing	62
5-3-1	Moment rigidity	62
5-3-2	Allowable moment	62
5-3-3	Momentary maximum Allowable moment	63
6	Performance Characteristics	64
6-1	Rigidity (Torsional rigidity and lost motion) and Backlash	64
6-1-1	Calculation of torsion (an example)	64
6-2	Vibration	65
6-3	Angular transmission accuracy	65
6-4	No-load running torque	66
6-5	Backdriving torque	66
6-6	Low-temperature characteristics	67
6-7	Efficiency charts	68
7	Installation and Assembly	69
7-1	Assembly accuracy	69
7-1-1	Assembly accuracy of RV-10C~ 500C	69
7-2	Installation procedure	70
7-2-1	Assembly example of center tube	70
7-2-2	Assembly example with the output-shaft bolt clamping type (RV-10C~ 500C)	70
7-2-3	Assembly example of through-bolt clamping output shaft type (RV-27C, 50C, 100C and 200C)	71
7-2-4	Assembly example of through-bolt clamping output shaft type (RV-10C and 320C)	71
7-3	Center gear and input gear	72
7-3-1	Accuracy of center gear and input gear	72
7-3-2	Standard center gear	72
7-4	Bolt tightening torque and allowable transmission torque	73
7-5	Installation of input gear	74
7-6	Lubrication	74
7-7	Warranty	76
8	External Dimensions	77
5	RV Series	
1	Construction	91
2	Rotary Direction and Speed Ratio	92
3	Ratings Table	93
4	RV Selection	95
4-1	Selection flow chart	95
4-2	Strength and Service Life	97
4-2-1	Allowable torque during acceleration or deceleration	97
4-2-2	Momentary maximum allowable torque	97
4-2-3	Rated Service Life	97
5	Performance Characteristics	98
5-1	Rigidity (Torsional rigidity and lost motion) and Backlash	98
5-1-1	Calculation of torsion (an example)	98
5-2	Vibration	99
5-3	Angular transmission accuracy	99
5-4	No-load running torque	100
5-5	Backdriving torque	100
5-6	Low-temperature characteristics	101
5-7	Efficiency charts	102
6	Installation and Assembly	103
6-1	Assembly accuracy	103
6-2	Installation	104
6-2-1	RV reduction gear setting hole	104
6-2-2	Fitting the RV reduction gear	104
6-3	Installation procedure	105
6-3-1	Installation of RV-15·RV-30	105
6-3-2	Installation of RV-60·RV-550	107
6-4	Bolt tightening torque and allowable transmission torque	109
6-5	Installation of input gear	110
6-5-1	Precautions for installation of RV-15 and RV-30 input gears	110
6-5-2	Pass-through capacity of input gear	111
6-5-3	An example of installation for the reduction gear with lower speed ratio	111
6-6	Lubrication	111
6-6-1	Grease lubrication	111
6-7	Warranty	112
7	External Dimensions	113
8	Application worksheet	127
9	Molywhite REOO Ordering information	128
10	Part Numbers lists	129

1 ORDERING INFORMATION

RV-E series

● Product identification for ordering purpose.

Type symbol ●

Frame No. ●

Frame number	Rated output torque In-lb(Nm)
6	514 (58)
20	1,479 (167)
40	3,649 (412)
80	6,944 (784)
110	9,547 (1078)
160	13,887 (1568)
320	27,774 (3136)
450	39,058 (4410)

Model ●

E Main bearing built-in type

● Bolt-clamping output shaft
B

● Bolt/pin clamping output shaft
P

● Type of input gear or input spline
A Standard type A (Narrow type)
B Standard type B (Big diameter type)
Z Special (none)

● Speed ratio (reduction ratio = $\frac{1}{R}$)

〈Ex. RV-80E〉

R	shaft rotation
	57,81,101,121,153

Notes 1. Refer to the Rating Table for other type.
2. Specify the shaft rotating speed ratio of your application.

RV-C series

● Product identification for ordering purpose.

Type symbol ●

Frame No. ●

Frame number	Rated output torque In-lb(Nm)
10	867 (98)
27	2,343 (265)
50	4,340 (490)
100	8,680 (980)
200	17,359 (1,961)
320	27,775 (3,136)
500	43,398 (4,900)

Model ●

C Hollow shaft type

● Bolt-clamping output shaft
B

● Through-bolt clamping output shaft
T

● Profile of center gear
A Standard type
Z None

● Speed ratio (reduction ratio = $\frac{1}{R}$)

Notes 1. Here, 36.75 applies to the RV-100C.
2. See Ratings Table for speed ratios of other frame numbers.
3. Specify the shaft rotating speed ratio of your application.

RV series

● Product identification for ordering purpose.

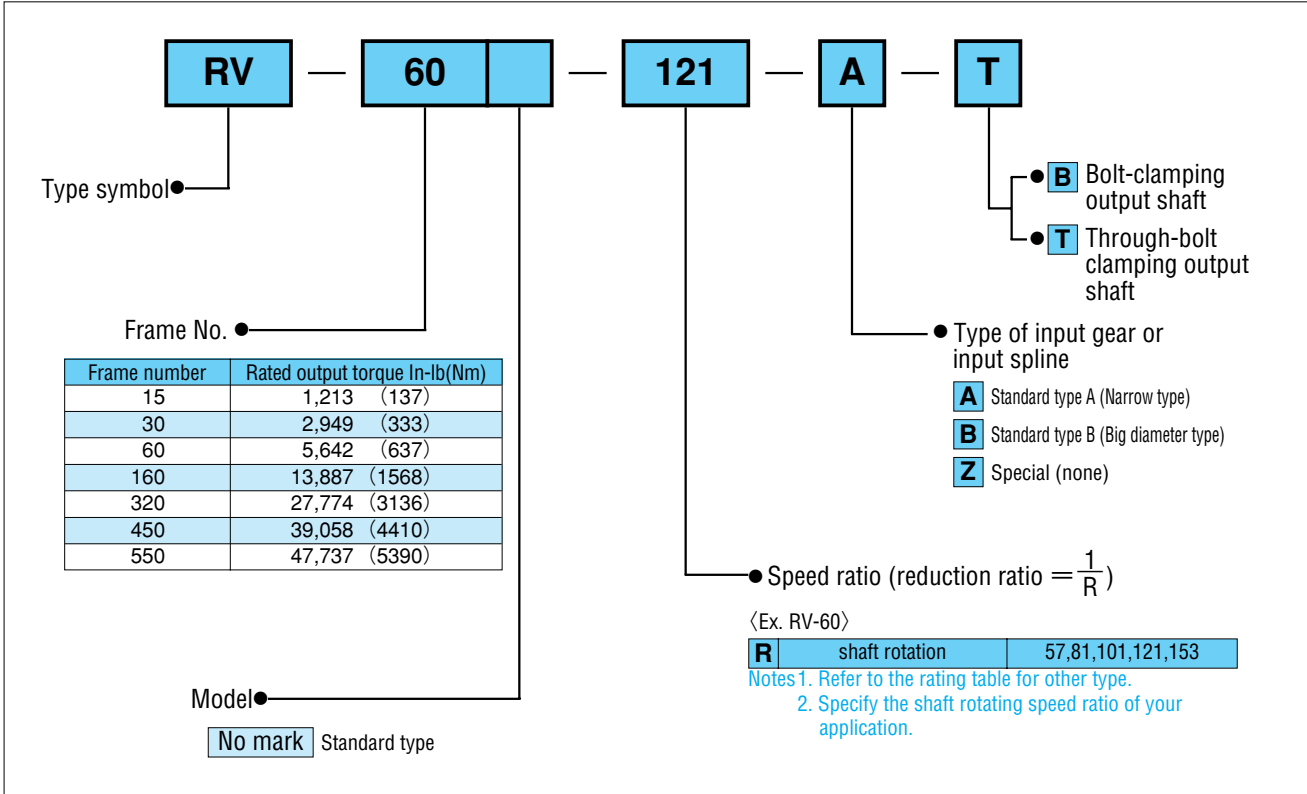

2 APPLICATION EXAMPLES

Robot Swing Axis RV-C series

- Allows space-saving design
- Main bearing is not required on robot side.

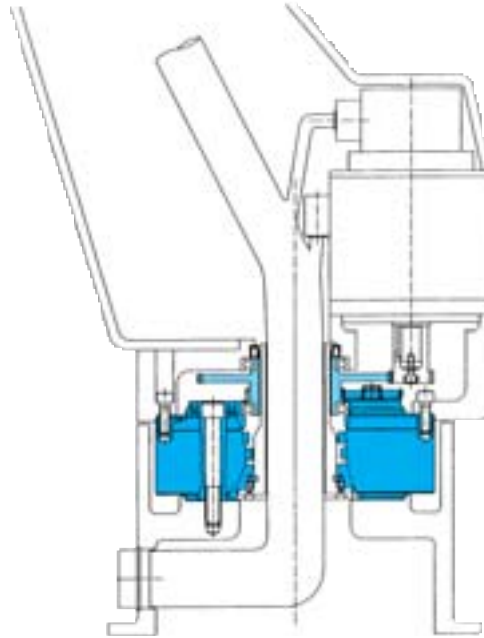

Robot arm RV-C series

- Greater internal resistance to adverse environments-allows safe throughput of cables.
- Wider operating angle.

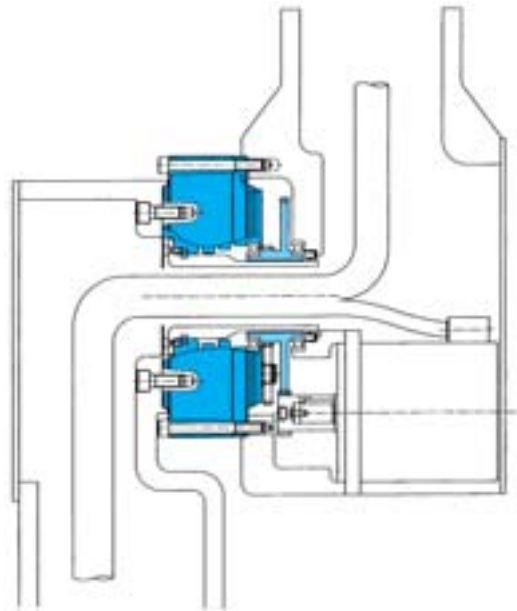

Indexing Table RV-C series

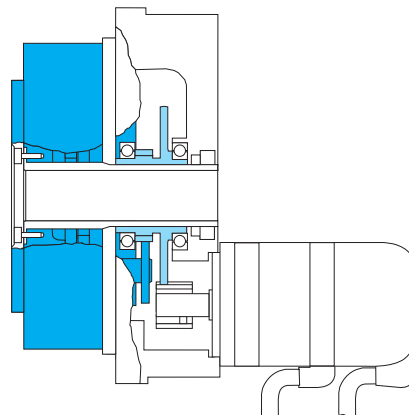

**Robot arm
RV-E series**

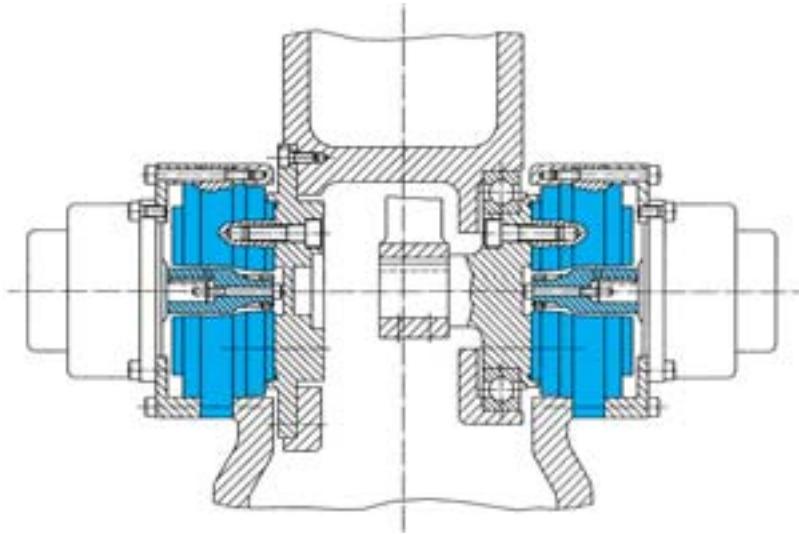

**Robot Wrist Axis
RV-E series**

As shown in the figure(right), the input gear can also be supported within the reduction gear mechanism.
Please contact Nabtesco for more details.

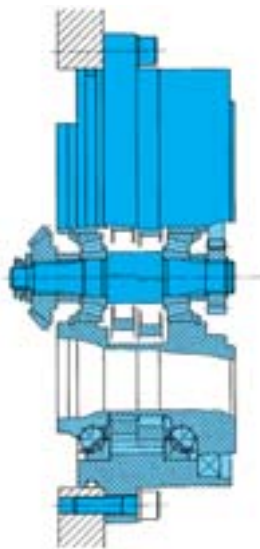

**Robot Swing Axis
RV series**

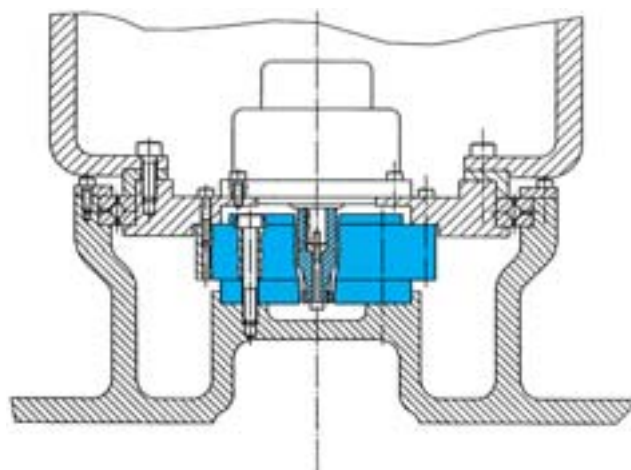

**Positioner
RV-E series**

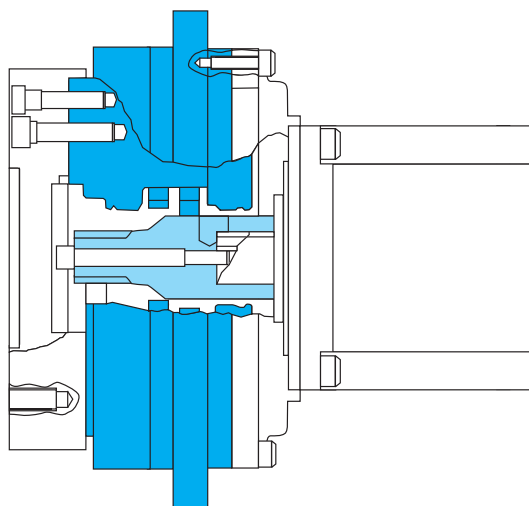

**ATC Magazine
RV-E series**

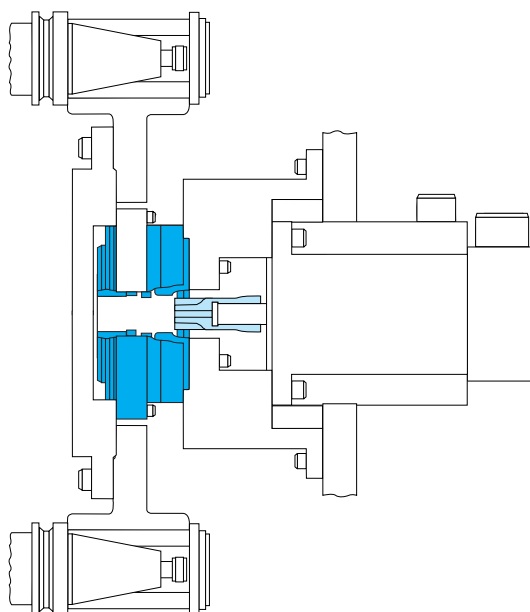

RV-E

series

1 FEATURES AND BENEFITS

Fig.1

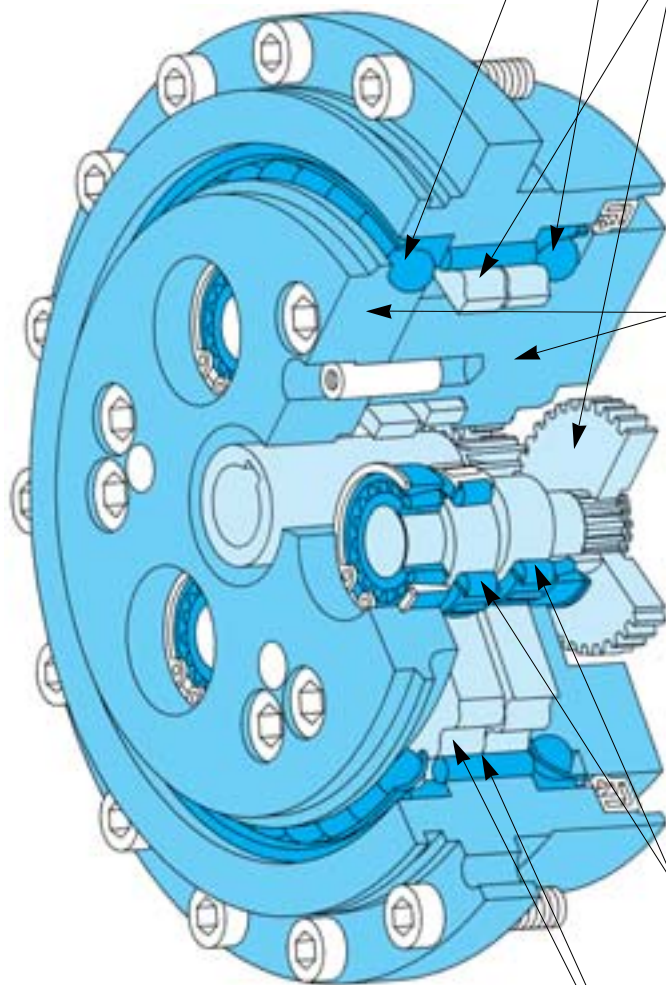

INTEGRATED ANGULAR BALL BEARINGS

Benefits:

- Increases reliability
- Reduces overall cost

Attributed to:

- Built-in angular ball bearing construction improves ability to support external loads, increases moment rigidity and maximum allowable moment.
- Reduces the number of components required.
- Simplifies installation and maintenance.

2 STAGE REDUCTION

Benefits:

- Reduces vibration
- Reduces inertia (GD^2)

Attributed to:

- Low speed rotation of the RV gear reduces vibration.
- Reduced size of the motor coupling part (input gear) lowers inertia.

ALL MAIN ELEMENTS ARE SUPPORTED ON BOTH SIDES

Benefits:

- Higher torsional stiffness
- Less vibration
- High shock load capability (5 times rated torque)

Detail:

- Crankshafts are supported on both sides of the reduction gear as shown below.

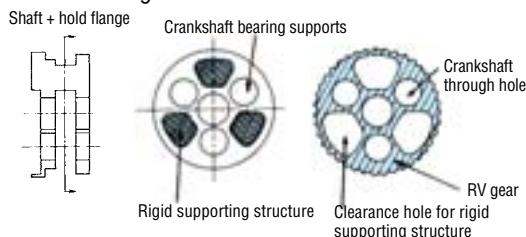

ROLLING CONTACT ELEMENTS

Benefits:

- Excellent starting efficiency
- Low wear and longer life
- Low backlash (Less than 1 arc. min.)

Attributed to:

- Use of roller bearings throughout.

PIN & GEAR STRUCTURE

Benefits:

- Very low backlash (Less than 1 arc. min.)
- Higher shock load capability (5 times rated torque)

Attributed to:

- Synchroneshing of many RV gear teeth and pins.

2 CONSTRUCTION and OPERATION PRINCIPLE

Construction

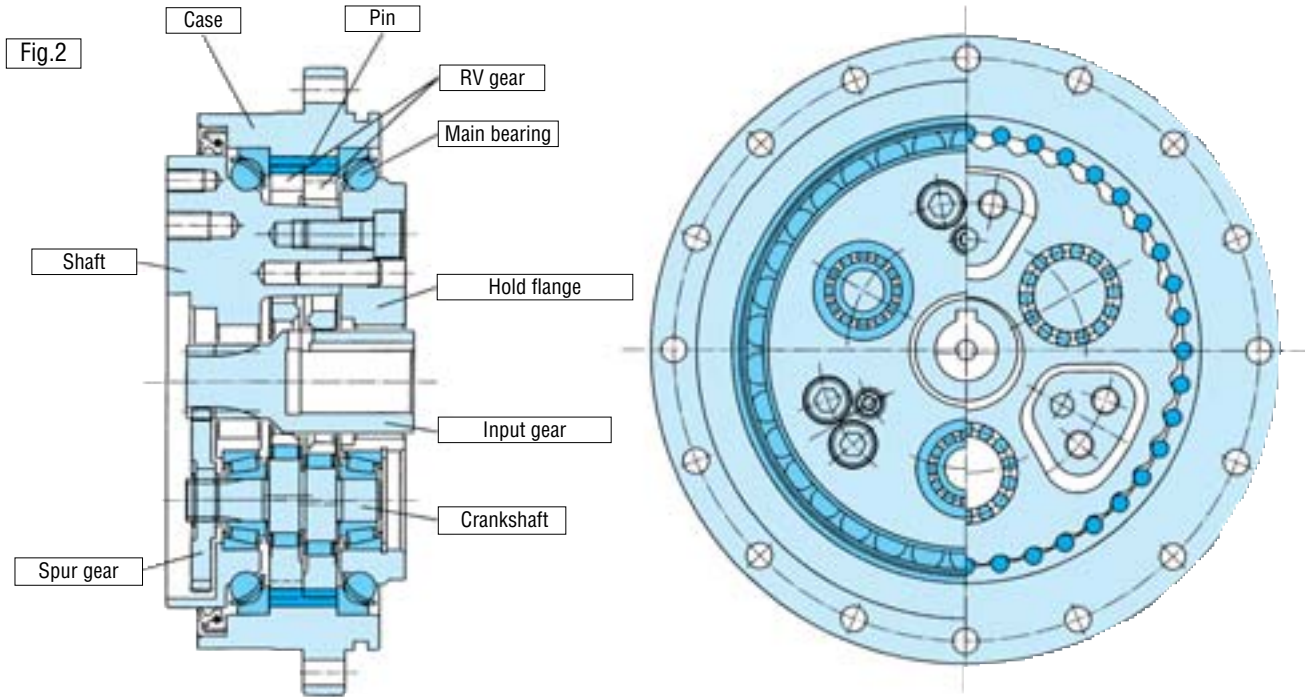

Principle of speed reduction

The RV-E is a 2-stage reduction gear.

1st stage ...Spur gear reduction

- An input gear engages with and rotates spur gears that are coupled to crankshafts. Several overall gear ratios can be provided by selecting various first stage ratios.

2nd stage ...Epicyclic gear reduction

- Crankshafts driven by the spur gears cause an eccentric motion of two epicyclic gears called RV gears that are offset 180 degrees from one another to provide a balanced load.
- The eccentric motion of the RV gears causes engagement of the cycloidal shaped gear teeth with cylindrically shaped pins located around the inside edge of the case.
- In the course of one revolution of the crankshafts the teeth of the RV gear move the distance of one pin in the opposite directions of the rotating cranks. The motion of the RV gear is such that the teeth remain in close contact with the pins and many teeth share the load simultaneously.
- The output can be either the shaft or the case. If the case is fixed, the shaft is the output. If the shaft is fixed, the case is the output (fig.4).

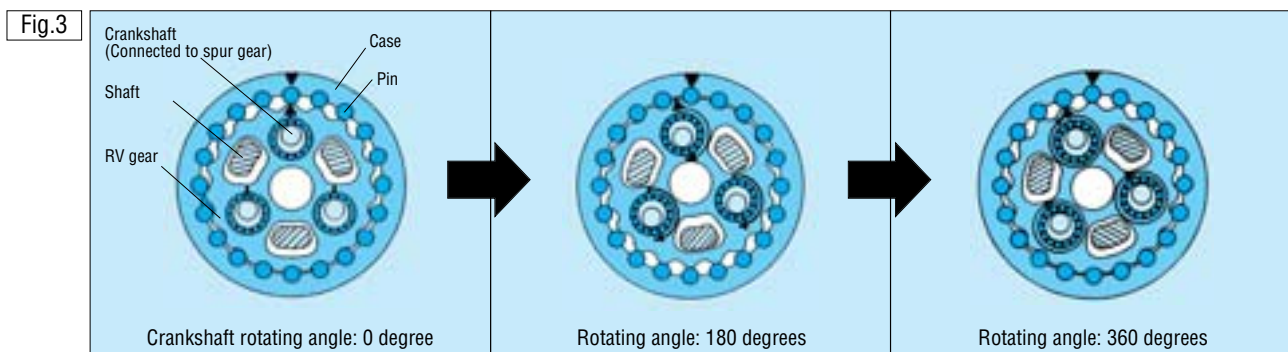

3 ROTARY DIRECTION and SPEED RATIO

The RV reduction gear may be used in various ways. The following figures show six combinations of the rotary direction and speed ratio. Use the following figure to select a mechanism most suitable for your application.

Fig.4

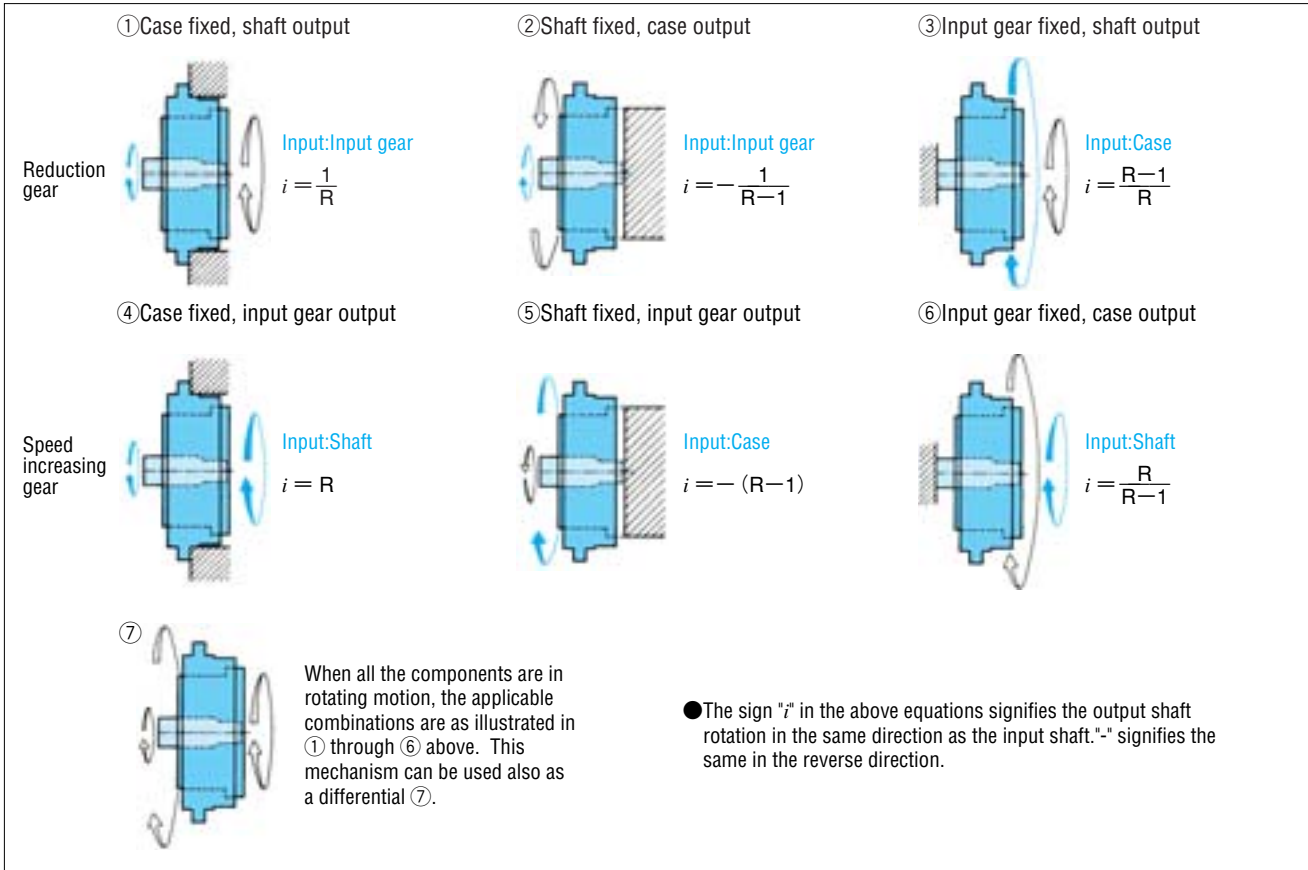

Mechanism block diagram

Fig.5

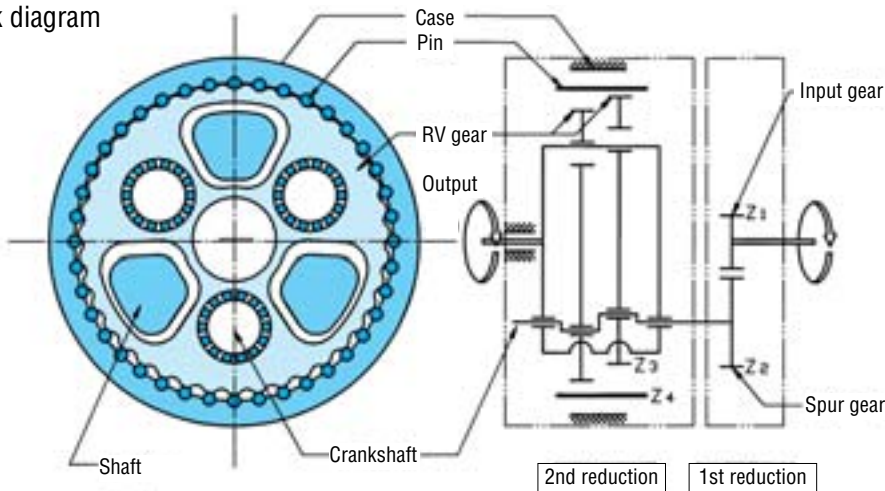

Speed Ratio

The overall ratio can be determined from the following equation:

With the shaft as output; $R = 1 + \frac{Z_2}{Z_1} \cdot Z_4$

$$i = \frac{1}{R}$$

- R : Speed ratio
- Z₁ : Number of teeth on input gear
- Z₂ : Number of teeth on spur gear
- Z₃ : Number of teeth on RV gear
- Z₄ : Number of pins
- i : Reduction ratio

4 RATING TABLE

Table 1

Output speed (r/min)			5		10		15		20		25		30		40	
Model	Speed ratio		Output torque	Input capacity	Output torque	Input capacity	Output torque	Input capacity	Output torque	Input capacity	Output torque	Input capacity	Output torque	Input capacity	Output torque	Input capacity
	Shaft rotation	Case rotation	In-lb (Nm)	kW	In-lb (Nm)	kW	In-lb (Nm)	kW	In-lb (Nm)	kW	In-lb (Nm)	kW	In-lb (Nm)	kW	In-lb (Nm)	kW
RV-6E	31	30	895 (101)	0.07	717 (81)	0.11	638 (72)	0.15	585 (66)	0.19	549 (62)	0.22	514 (58)	0.25	478 (54)	0.30
	43	42														
	53.5	52.5														
	59	58														
	79	78														
103	102															
RV-20E	57	56	2,046 (231)	0.16	1,665 (188)	0.26	1,479 (167)	0.35	1,355 (153)	0.43	1,266 (143)	0.50	1,196 (135)	0.57	1,098 (124)	0.70
	81	80														
	105	104														
	121	120														
	141	140														
161	160															
RV-40E	57	56	5,066 (572)	0.40	4,118 (465)	0.65	3,649 (412)	0.86	3,339 (377)	1.05	3,126 (353)	1.23	2,958 (334)	1.40	2,719 (307)	1.71
	81	80														
	105	104														
	121	120														
	153	152														
RV-80E	57	56	9,636 (1,088)	0.76	7,838 (885)	1.24	6,944 (784)	1.64	6,368 (719)	2.01	5,952 (672)	2.35	5,642 (637)	2.67	5,172 (584)	3.26
	81	80														
	101	100														
	121	120														
	※1 (153)	※1 (152)														
RV-110E	81	80	13,276 (1,499)	1.05	10,761 (1,215)	1.70	9,547 (1,078)	2.26	8,768 (990)	2.76	8,192 (925)	3.23	7,750 (875)	3.67	7,121 (804)	4.49
	111	110														
	161	160														
	※2 175.28	174.28														
RV-160E	81	80	19,272 (2,176)	1.52	15,712 (1,774)	2.48	13,887 (1,568)	3.28	12,762 (1,441)	4.02	11,894 (1,343)	4.69	11,283 (1,274)	5.34		
	101	100														
	129	128														
	145	144														
	171	170														
RV-320E	81	80	38,624 (4,361)	3.04	31,335 (3,538)	4.94	27,774 (3,136)	6.57	25,516 (2,881)	8.05	23,869 (2,695)	9.41	22,567 (2,548)	10.7		
	101	100														
	118.5	117.5														
	129	128														
	141	140														
	171	170														
185	184															
RV-450E	81	80	54,335 (6,135)	4.28	44,088 (4,978)	6.95	39,058 (4,410)	9.24	35,843 (4,047)	11.3	33,505 (3,783)	13.2				
	101	100														
	118.5	117.5														
	129	128														
	※2 154.8	153.8														
	171	170														
※2 192.4	191.4															

Notes: 1. Set maximum input shaft revolutions to a value equal to or lower than the value of maximum allowable output revolutions multiplied by the above speed ratio for each type.

2. The input capacity (kW) in the above table is determined by the efficiency of these reduction gears.

3. The output torque (In-lb) is so determined that the service life may be maintained constant for any output revolutions. ($N \cdot T^{10} = \text{Constant}$)

4. The rated torque is a torque at an output speed of 15 r/min, which is used as a basis for service life calculations. (Refer to the rated service life, page 15) The RV-6E, however, has its rated torque determined as the output torque at an output speed of 30 r/min.

5. The $\frac{GD^2}{4}$ value is a value considering both gear tooth widths of reduction gear assembly and input gear. The $\frac{GD^2}{4}$ value at the shaft of the input gear is not included.

50		60		Moment rigidity (Typical Value) In-lb/ arc.min. (Nm/arc.min.)	Allowable moment In-lb (Nm)	Momentary max. allowable moment (Shockload) In-lb (Nm)	Allowable max. output speed (Continuous) r/min	Allowable acceleration/ deceleration torque In-lb (Nm)	Momentary max. allowable torque (E-stop) In-lb (Nm)	Lost motion MAX. arc.min.	Torsional rigidity (Stiffness) (Typical Value) In-lb/ arc.min. (Nm/arc.min.)	$I(= \frac{GD^2}{4})$ (Input inertia)		Weight lb (kg)
Output torque	Input capacity	Output torque	Input capacity									Tooth width mm	kg-m ²	
In-lb (Nm)	kW	In-lb (Nm)	kW											
443 (50)	0.35	416 (47)	0.40	1,036 (117)	1,736 (196)	3,472 (392)	100	1,036 (117)	2,604 (294)	1.5'	177 (20)	6	3.75×10 ⁻⁶	5.5 (2.5)
													2.60×10 ⁻⁶	
													1.84×10 ⁻⁶	
													1.63×10 ⁻⁶	
													1.09×10 ⁻⁶	
0.79×10 ⁻⁶														
1,019 (115)	0.81	974 (110)	0.92	3,295 (372)	7,812 (882)	15,623 (1,764)	75	3,649 (412)	7,378 (833)	1'	434 (49)	8	1.08×10 ⁻⁵	9.68 (4.4)
													0.65×10 ⁻⁵	
													0.45×10 ⁻⁵	
													0.37×10 ⁻⁵	
													0.29×10 ⁻⁵	
0.24×10 ⁻⁵														
2,542 (287)	2.00	2,400 (271)	2.27	8,245 (931)	14,755 (1,666)	29,510 (3,332)	70	9,113 (1,029)	18,227 (2,058)	1'	957 (108)	10	3.75×10 ⁻⁵	20.9 (9.5)
													2.40×10 ⁻⁵	
													1.72×10 ⁻⁵	
													1.43×10 ⁻⁵	
													1.03×10 ⁻⁵	
4,836 (546)	3.81	4,579 (517)	4.33	10,415 (1,176)	Bolt joint 19,095 (2,156) Pin/bolt joint 15,366 (1,735)	Bolt joint 38,190 (4,312) Pin/bolt joint 19,095 (2,156)	70	17,359 (1,960)	Bolt joint 34,718 (3,920) Pin/bolt joint 28,208 (3,185)	1'	1,736 (196)	10	8.28×10 ⁻⁵	27.9 (12.7)
													5.65×10 ⁻⁵	
													4.40×10 ⁻⁵	
													3.53×10 ⁻⁵	
													2.63×10 ⁻⁵	
				13,019 (1,470)	26,038 (2,940)	52,077 (5,880)	50	23,869 (2,695)	47,737 (5,390)	1'	2,604 (294)	13	1.08×10 ⁻⁴	39.6 (18.0)
													0.73×10 ⁻⁴	
													0.45×10 ⁻⁴	
													0.40×10 ⁻⁴	
				26,038 (2,940)	34,718 (3,920)	Bolt joint 69,436 (7,840) Pin/bolt joint 59,888 (6,762)	45	34,718 (3,920)	Bolt joint 69,436 (7,840) Pin/bolt joint 58,586 (6,615)	1'	3,472 (392)	15	1.96×10 ⁻⁴	61.6 (28)
													1.51×10 ⁻⁴	
													1.11×10 ⁻⁴	
													0.90×10 ⁻⁴	
0.76×10 ⁻⁴														
				43,397 (4,900)	Bolt joint 62,492 (7,056) Pin/bolt joint 54,681 (6,174)	Bolt joint 124,984 (14,112) Pin/bolt joint 97,210 (10,976)	35	69,436 (7,840)	Bolt joint 138,872 (15,680) Pin/bolt joint 108,493 (12,250)	1'	8,679 (980)	16	5.23×10 ⁻⁴	103.4 (47)
													4.00×10 ⁻⁴	
													3.28×10 ⁻⁴	
													2.95×10 ⁻⁴	
													2.63×10 ⁻⁴	
2.01×10 ⁻⁴														
1.79×10 ⁻⁴														
				65,964 (7,448)	78,115 (8,820)	Bolt joint 156,230 (17,640) Pin/bolt joint 119,777 (13,524)	25	97,644 (11,025)	Bolt joint 195,288 (22,050) Pin/bolt joint 164,910 (18,620)	1'	10,415 (1,176)	18	8.93×10 ⁻⁴	151.8 (69)
													6.95×10 ⁻⁴	
													5.75×10 ⁻⁴	
													5.18×10 ⁻⁴	
													4.08×10 ⁻⁴	
3.58×10 ⁻⁴														
3.03×10 ⁻⁴														

6. If a higher speed than the above allowable maximum output speed is required, contact Nabtesco for further information.

7. If other speed ratio than the above list is required, contact Nabtesco for further information.

8. *1 RV-80E, R=153 is used only for output shaft bolt-on type. (page 25)

*2 These reduction gear ratios are indivisible figures. Actually, 175.2=1,227/7, 154.8=2,013/13 and 192.4=1,347/7.

9. The output revolution is for forward-reverse changeover applications and not applicable for continuous rotation in a single direction. Contact us when using the reduction gear for continuous single-direction rotation.

5 RV-E SELECTION

5-1 Selection flow chart

Determine load characteristics

Check the load torque applied to the reduction gear. An example is shown in fig. 6.

- Calculate average load torque (T_m)
- Calculate average output speed (N_m)

$$T_m = \frac{10}{9} \sqrt{\frac{t_1 \cdot N_1 \cdot T_1^{10} + t_2 \cdot N_2 \cdot T_2^{10} + \dots + t_n \cdot N_n \cdot T_n^{10}}{t_1 \cdot N_1 + t_2 \cdot N_2 + \dots + t_n \cdot N_n}}$$

$$N_m = \frac{t_1 \cdot N_1 + t_2 \cdot N_2 + \dots + t_n \cdot N_n}{t_1 + t_2 + \dots + t_n}$$

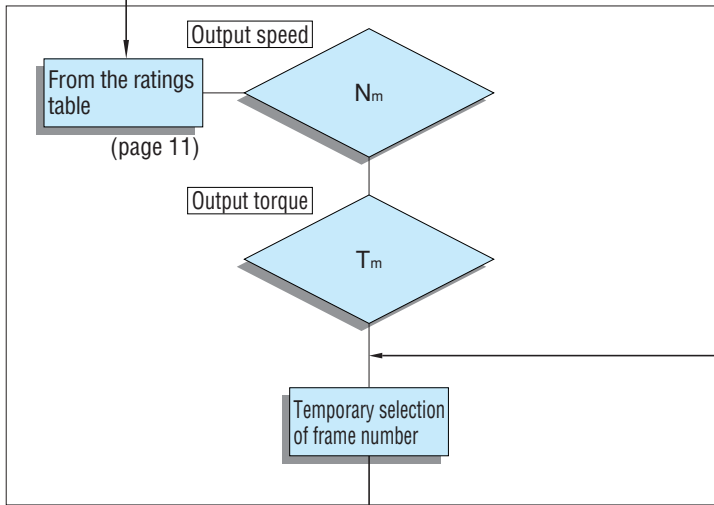
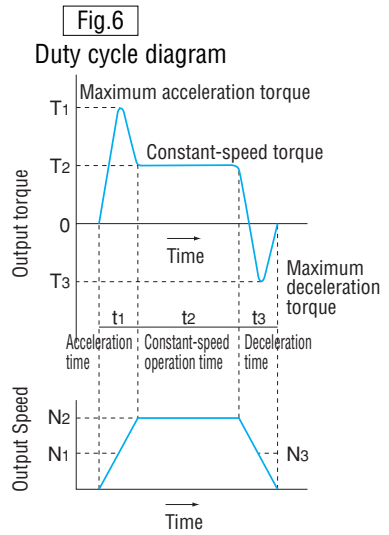
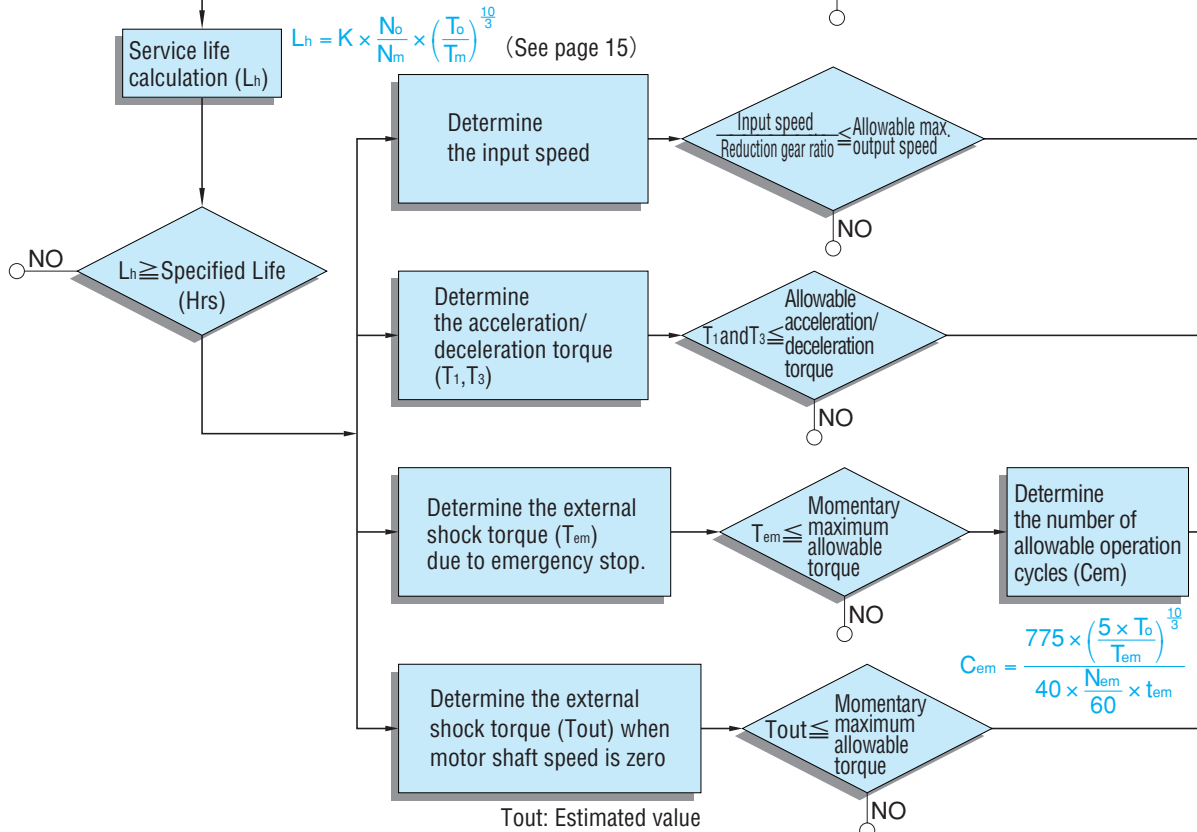
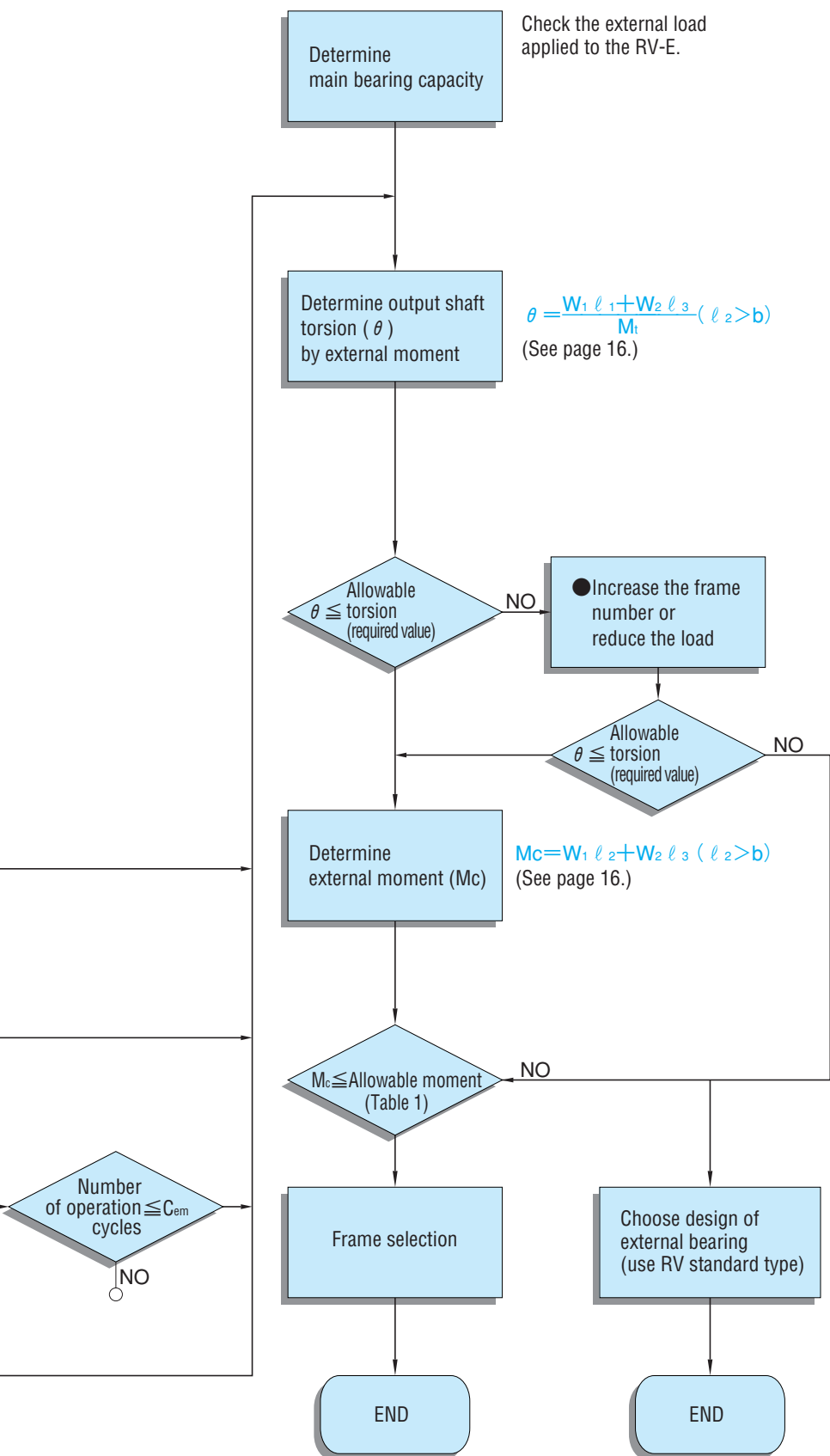

Table 2 Conditions to be determined for selection

	For starting (Max)	For constant speed	For stopping (Max)	For impact due to emergency stop
Load torque	In-lb T ₁	T ₂	T ₃	T _{em}
Speed	r/min N ₁	N ₂	N ₃	N _{em}
Time	sec t ₁	t ₂	t ₃	t _{em}





Selection example

Selection conditions

$T_1=22,125\text{In-lb}$ $T_2=4,425\text{In-lb}$
 $T_3=13,275\text{In-lb}$ $T_{em}=61,950\text{In-lb}$
 $t_1=0.2\text{sec.}$ $t_2=0.5\text{sec.}$
 $t_3=0.2\text{sec.}$ $t_{em}=0.05\text{sec.}$
 $N_1=N_3=10\text{r/min}$ $N_2=20\text{r/min}$
 $N_{em}=20\text{r/min}$

Determine load characteristic

- Determine average load torque

$$T_m = \sqrt[10]{\frac{0.2 \times 10 \times 22,125^{10} + 0.5 \times 20 \times 4,425^{10} + 0.2 \times 10 \times 13,275^{10}}{0.2 \times 10 + 0.5 \times 20 + 0.2 \times 10}}$$

$$= 13,053\text{In-lb}$$

- Determine average output speed

$$N_m = \frac{0.2 \times 10 + 0.5 \times 20 + 0.2 \times 10}{0.2 + 0.5 + 0.2} = 15.6\text{r/min}$$

Provisional selection of RV-160E-129.

- Calculation to determine whether reduction gear service life meets required specification value.

$$L = 6,000 \times \frac{15}{15.6} \times \left(\frac{13,887}{13,053}\right)^{10} = 7,092\text{Hr}$$

- Determine output speed

Maximum output speed $20\text{r/min} < 45\text{r/min}$

(Maximum allowable output speed of RV-160E)

- Determine torque during starting and stopping

$T_1=22,125\text{In-lb} < 34,718\text{In-lb}$
 (Allowable acc./dec. torque for RV-160E)
 $T_3=13,275\text{In-lb} < 34,718\text{In-lb}$
 (Allowable acc./dec. torque for RV-160E)

- Determine emergency stop and external shock torque

$T_{em}=61,950\text{In-lb} < 69,436\text{In-lb}$
 (Momentary max. allowable torque for RV-160E)

$$C_{em} = \frac{775 \times \left(\frac{5 \times 13,887}{61,950}\right)^{10}}{40 \times \frac{20}{60} \times 0.05} = 1,700 \text{ times}$$

Determine main bearing capacity

- External load conditions

$W_1=660\text{lbs}$ $l_1=19.7\text{in.}$
 $W_2=330\text{lbs}$ $l_3=7.9\text{in.}$

Determine moment rigidity

- Determine whether output shaft deflection angle meets required specification value.

$$\theta = \frac{660 \times 19.7 + 330 \times 7.9}{26,019} = 0.6(\text{arc.min})$$

- Determine external moment

$$l_2 = 19.7 + \frac{8.3}{2} = 23.85\text{in.}$$

$$M_c = 660 \times 23.85 + 330 \times 7.9 = 18,348\text{In-lb} < 34,718\text{In-lb}$$

(Allowable moment of RV-160E)

Since all required specification are satisfied, select RV-160E-129.

5-2 Strength and service life

5-2-1 Allowable torque during acceleration or deceleration

When the Machine starts (or stops) a larger torque than steady-state torque is applied to the reduction gear because of the internal loads. The values in the ratings table (see page 11) show the allowable value of the peak torque when the reduction gear starts or stops.

With the RV-6E, the allowable acceleration/deceleration torque is 200% of the rated torque; other models in the series have a acceleration/deceleration torque of 250% of the rated torque.

5-2-2 Momentary maximum allowable torque

A large torque during an emergency stop or external shock may be applied to the reduction gear. The maximum allowable torque is shown in the ratings table(see page 11).

Momentary maximum allowable torque is 500% of the rated torque.

Note) When shock torque is applied, be sure to use at below the limit cycles(refer to selection flowchart on page 13).

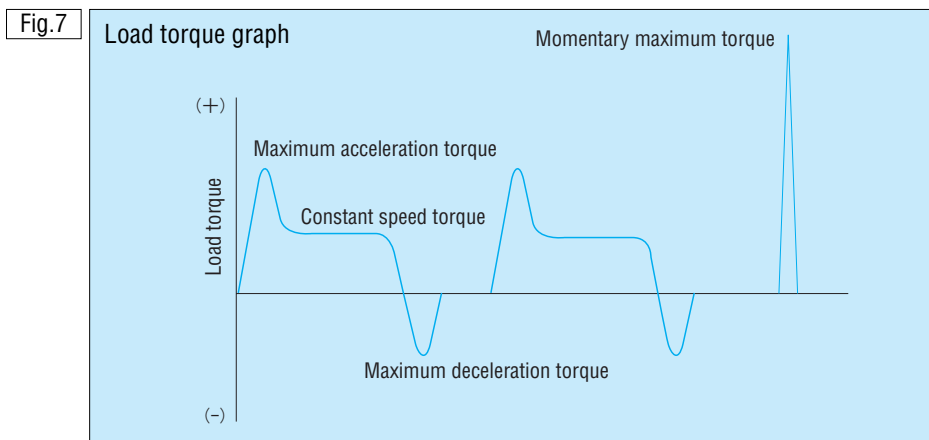

5-2-3 Rated service life

The service life of the RV-E reduction gear is based on the life of the roller bearings of the crankshafts. The service life is set as shown in Table 3 for all models and ratios at rated torque and at rated output speed.

L_h	Service life (Hrs)	
L_{10}	K	6,000

When in actual service installed in the equipment, calculate the service life using the following formula because the load condition depends on the types of reduction gear.

$$L_h = K \times \frac{N_o}{N_m} \times \left(\frac{T_o}{T_m} \right)^{\frac{10}{3}}$$

- L_h : Service life to be obtained (Hr)
- N_m : Average output speed (r/min) (calculation on page 13)
- T_m : Average output torque (In-lb) (calculation on page 13)
- N_o : Rated output speed (r/min) (table 4)
- T_o : Rated output torque (In-lb) (table 4)

Type	Rated torque(T_o) In-lb(Nm)	Rated output speed (N_o)r/min
RV-6E	514 (58)	30
RV-20E	1,479 (167)	15
RV-40E	3,649 (412)	
RV-80E	6,944 (784)	
RV-110E	9,547 (1,078)	
RV-160E	13,887 (1,568)	
RV-320E	27,774 (3,136)	
RV-450E	39,058 (4,410)	

5-3 Capacity of main bearing

The RV-E series incorporates angular contact ball bearings so that external loads may be supported.

5-3-1 Moment rigidity

When an external load is applied to the output shaft, its deflection angle is proportional to the external moment (where $l_2 > b$).

The moment rigidity is expressed as an external moment value, which is required to deflect the output shaft 1 arc. min.

$$\theta = \frac{W_1 l_1 + W_2 l_3}{M_t}$$

- θ : Deflected angle of output shaft (arc.min.)
- M_t : Moment rigidity (In-lb/arc.min.) (table 5)
- W_1, W_2 : Weight (lbs)
- l_1, l_3 : Arm length (in.)
- $l_1 = l + \frac{b}{2} - a$
- l : The distance between the output shaft mounting surface and the loading point (in.)

Fig.8 External loading diagram

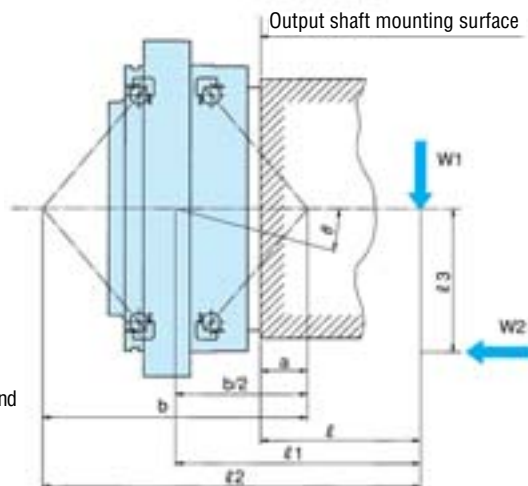

Table 5

Model	Moment rigidity (Mt) In-lb/arc.min. (Typical Value)	Size (in.)	
		a	b
RV-6E	1,036	0.69	3.61
RV-20E	3,295	0.79	4.46
RV-40E	8,245	1.17	5.66
RV-80E※1	10,415	1.31	6.54
RV-80E※2	10,415	1.47	6.54
RV-110E	13,019	1.27	6.95
RV-160E	26,038	1.88	8.30
RV-320E	43,397	2.22	9.90
RV-450E	65,964	2.72	11.52

- ※1 Bolt mounting output-shaft type
- ※2 Pin/bolt mounting output shaft type

5-3-2 Allowable moment

Table 6 shows the external moment values (moments during starting and stopping, etc.) and allowable thrust load that can be supported by the RV-E Series. Refer to figure 9 indicating the range of allowable moment for simultaneous application of external moment and external thrust.

$$M_c \leq \text{Allowable moment}$$

$$M_c = W_1 l_2 + W_2 l_3 \quad (l_2 > b)$$

- M_c : External moment (In-lb)
- W_1, W_2 : Weight (lbs)
- l_2, l_3 : Distance to load point (in.)
- $l_2 = l + b - a$
- l : The distance between the output shaft mounting surface and the loading point (in.)

Note) Allowable moment differs depending on two types of model: output shaft bolt-mounting type and output shaft bolt/pin mounting type.

Table 6

Model	Allowable moment In-lb(Nm)	Allowable thrust lbs(N)
RV-6E	1,736 (196)	331 (1,470)
RV-20E	7,812 (882)	882 (3,920)
RV-40E	14,755 (1,666)	1,168 (5,194)
RV-80E※1	19,095 (2,156)	1,764 (7,840)
RV-80E※2	15,366 (1,735)	1,764 (7,840)
RV-110E	26,038 (2,940)	2,425 (10,780)
RV-160E	34,718 (3,920)	3,307 (14,700)
RV-320E※1	62,492 (7,056)	4,409 (19,600)
RV-320E※2	54,681 (6,174)	4,409 (19,600)
RV-450E	78,115 (8,820)	5,511 (24,500)

- ※1 Bolt mounting output shaft type
- ※2 Pin/bolt mounting output shaft type

Fig.9 Allowable moment diagram

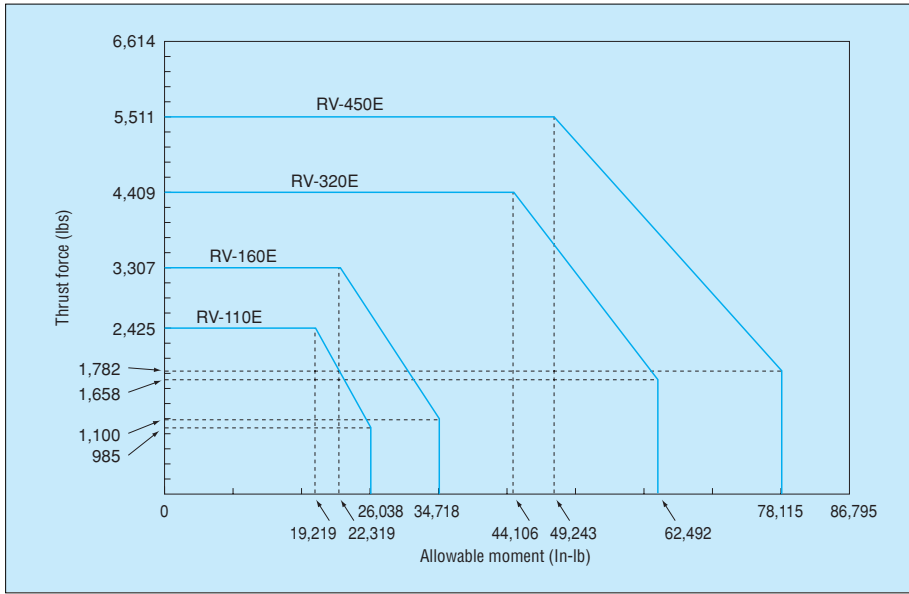
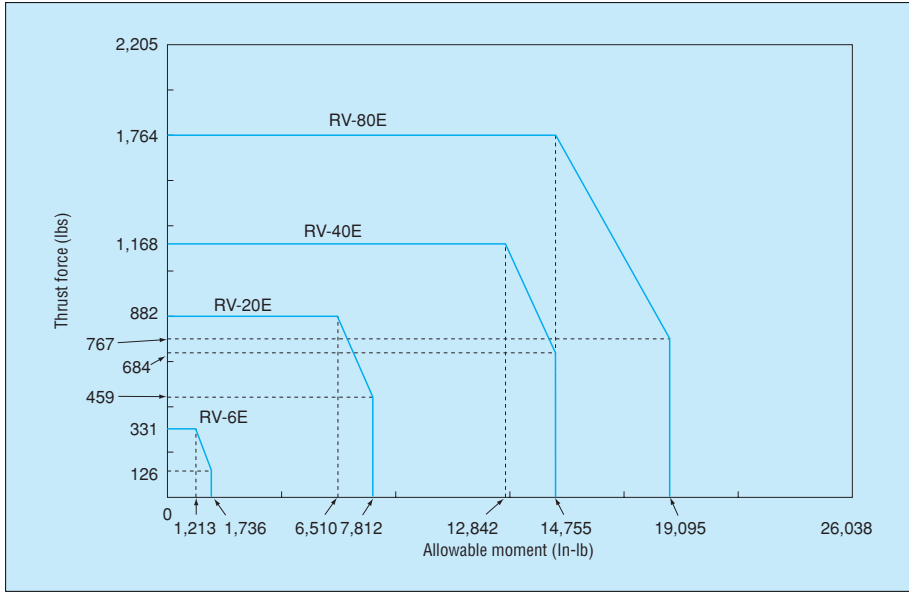

5-3-3 Momentary maximum allowable moment

A large torque and moment due to emergency stop or external impact may be applied to the reduction gear.

The maximum allowable moment is shown in the rating table.
(See page 11)

Note) On some types of reduction gears the momentary maximum allowable moment varies depending on types of bolt joint or pin/bolt joint output shaft.

6-1 Rigidity (Torsional rigidity and lost motion) and backlash

When a torque is applied to the output shaft while the input shaft (input gear) is fixed, torsion is generated according to the torque value and a hysteresis curve result is shown in Fig. 10.

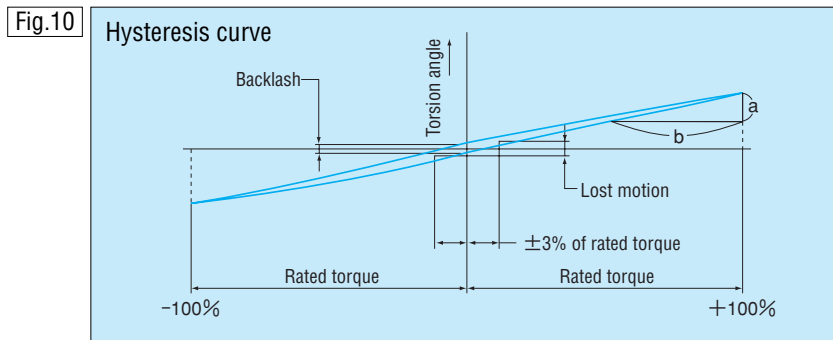

The rigidity of the reduction gear is expressed by the torsional rigidity and the lost motion in this curve. RV reduction gears are especially superior in their stiffness characteristics.

- Torsional rigidity = $\frac{b}{a}$

- Lost motion

The torsion angle at the mid point of the hysteresis curve width at $\pm 3\%$ of rated torque.

- Backlash

The torsion angles when the torque indicated by the hysteresis curve is zero.

6-1-1 Calculation of torsion (an example)

Take an example of the RV-160E and find the torsion where a torque is applied in one direction.

1) If a torque of 265.5 In-lb is applied, the resulting torsion ST_1 , is found as shown below.

- Note that the torque is in the lost motion range.

$$ST_1 = \frac{265.5}{416.0} \times \frac{1(\text{arc.min.})}{2} = 0.32 \text{ arc.min.}$$

2) If a torque of 11,505 In-lb is applied, the resulting torsion ST_2 is found as shown below.

- Note that the torque is in the rated torque range.

$$ST_2 = \frac{1}{2} + \frac{11,505 - 416}{3,472} = 3.70 \text{ arc.min.}$$

Notes) 1. The above torsion value is that of the reduction gear assembly.

2. For special specifications of backlash and lost motion, contact Nabtesco.

Table 7

Model	Torsional rigidity In-lb/arc.min.	Lost motion		Backlash arc.min.
		Lost motion arc.min.	Measured torque In-lb	
RV-6E	177	MAX1	± 15.6	MAX1.5
RV-20E	434		± 44.3	
RV-40E	957		± 108.9	
RV-80E	1,736		± 208.0	MAX1
RV-110E	2,604		± 285.9	
RV-160E	3,472		± 416.0	
RV-320E	8,679		± 831.9	
RV-450E	10,415		± 1,168.2	

6-2 Vibration

The vibration is a torsional vibration in the circumferential direction when driven by a servomotor with an inertia load applied.

The vibration is one of the most important characteristics, especially when precise contouring control is required. For example, the industrial robot requires exact and smooth contour control for its longer arm. An actual measured example of the vibration characteristics is shown in Fig. 11.

Fig.11

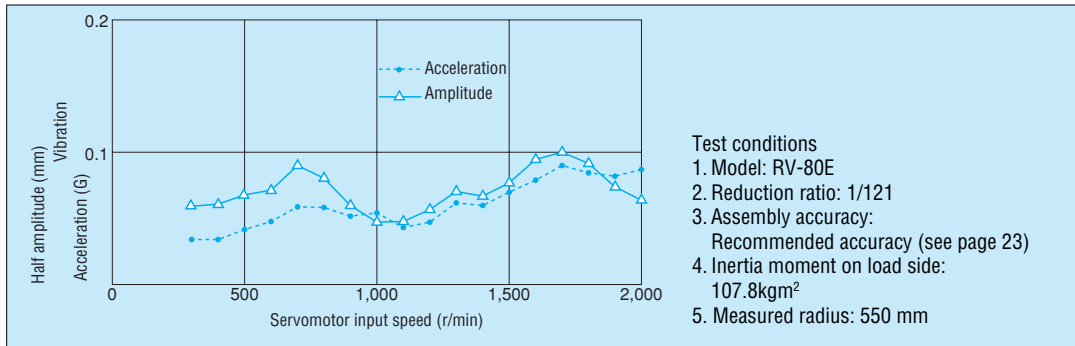

6-3 Angular transmission accuracy

Angular transmission accuracy refers to a difference between the theoretical output revolution angle and the actual revolution angle (θ out) when any revolution angle (θ in) is the input, and is expressed as an angular transmission error (θ er). The angular transmission error is found in the following equation.

$$\theta \text{ er} = \frac{\theta \text{ in}}{R} - \theta \text{ out} \quad (\text{where } R = \text{reduction ratio})$$

The measured example is shown below.

Fig.12

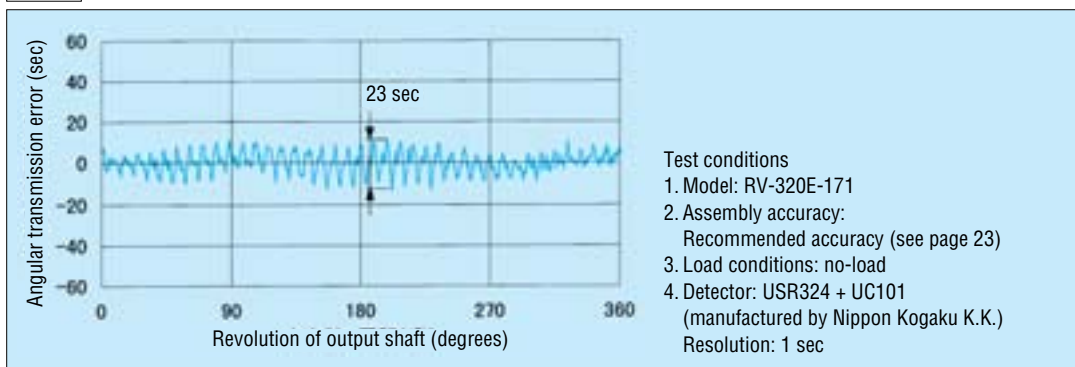

6-4 No-load running torque

The no-load running torque means a torque required on the input shaft (input gear) side in order to rotate the RV-E reduction gear under no load. Fig. 13 shows the no-load running torque on the output shaft side, which is converted from the no-load running torque according to the following equation.

● No-load running torque converted to motor shaft (In-lb)

$$= \frac{\text{converted torque on the output shaft side}}{R} \quad (\text{where } R = \text{speed ratio})$$

Note: The diagram below shows average values obtained after a RV-E reduction gear has been run in.

Fig.13

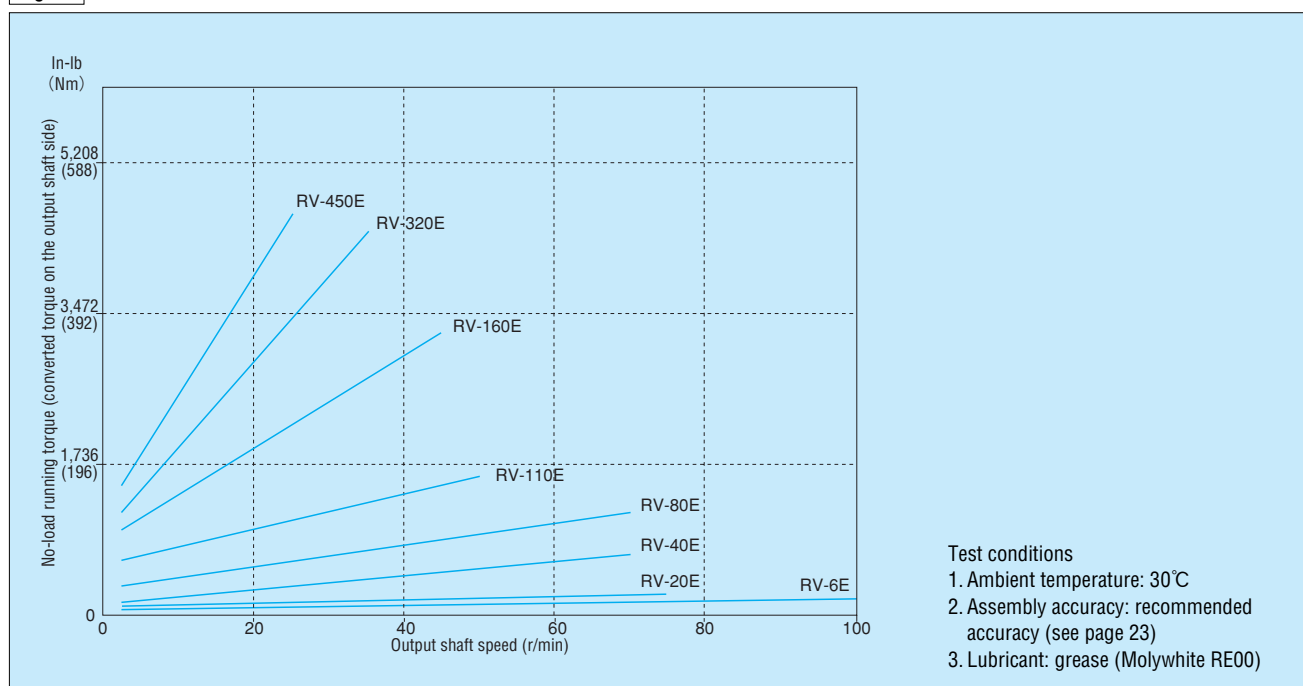

6-5 Backdriving torque

The backdriving torque refers to a torque required for starting the output shaft, with the RV-E reduction gear left under no load. If the input shaft (input gear) is released while a torque equal to or more than the backdriving torque is kept applied to the output shaft, the input shaft (input gear) starts running at an augmented speed. Special care should be given to the backdriving torque required to start the RV-E reduction gear.

Table 8

Model	Backdriving torque In-lb(Nm)
RV-6E	89 (10)
RV-20E	372 (42)
RV-40E	416 (47)
RV-80E	620 (70)
RV-110E	709 (80)
RV-160E	974 (110)
RV-320E	1,948 (220)
RV-450E	2,391 (270)

Test conditions
 Assembly accuracy: recommended accuracy
 (see page 23)
 Lubricant: grease (Molywhite RE00)

6-6 Low-temperature Characteristics (No-load running torque under low temperature)

Test conditions

1. Assembly accuracy: recommended accuracy (see page 23)
2. Lubricant: grease (Molywhite RE00)
3. Input speed: 2,000 r/min

When the RV-E reduction gear is used under a low temperature, viscosity of lubricant increases and causes a larger no-load running torque. The no-load running torque under low temperature is shown below.

Fig.14

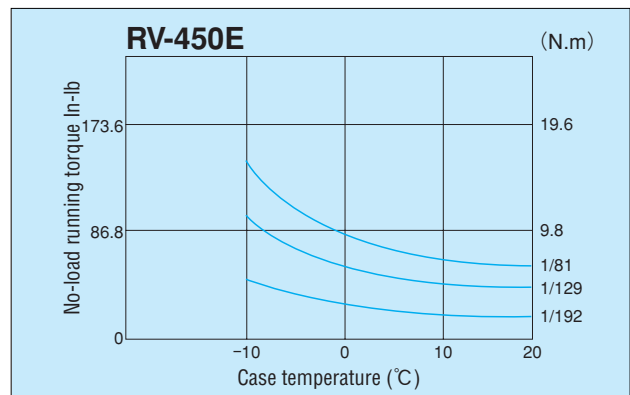
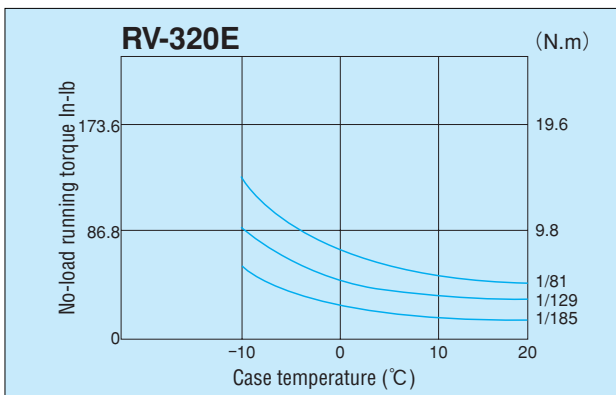
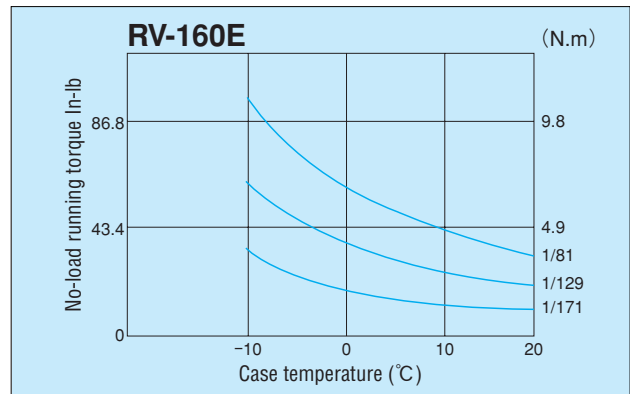
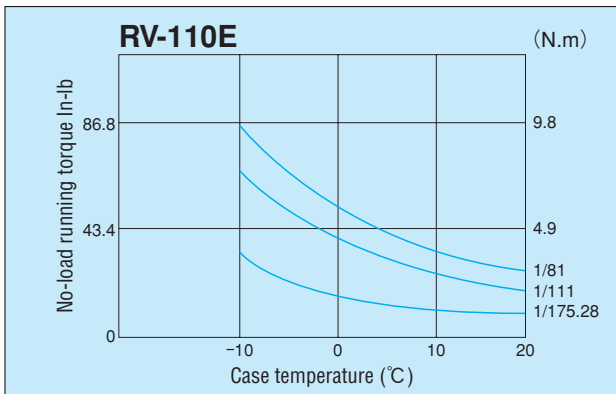
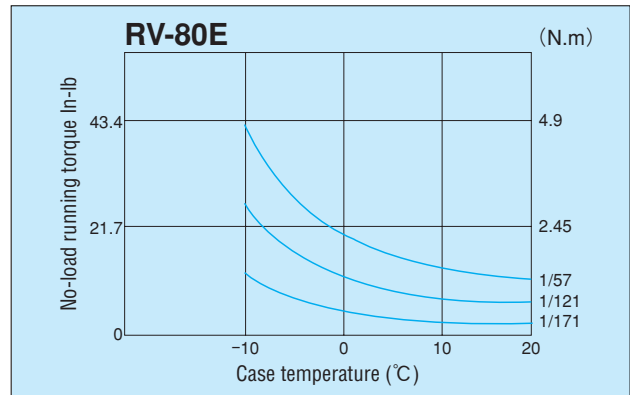
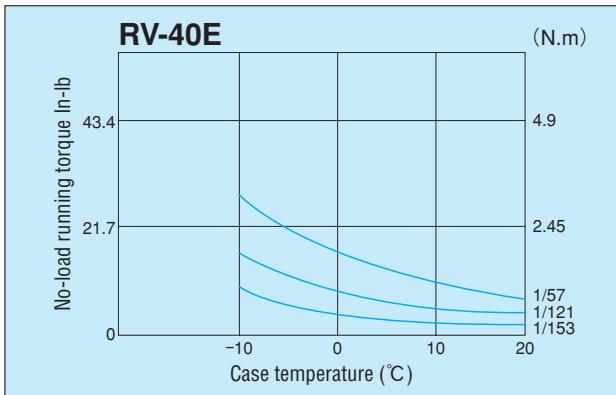
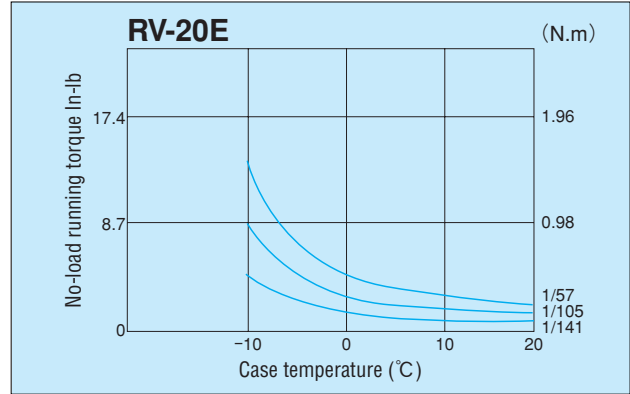
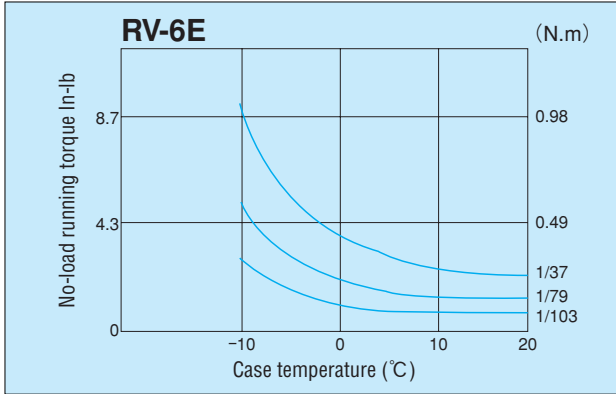

6-7 Efficiency charts

Test conditions

1. Case temperature: 30°C
2. Assembly accuracy: recommended accuracy (see page 23)
3. Lubricant: grease (Molywhite RE00)

Fig.15

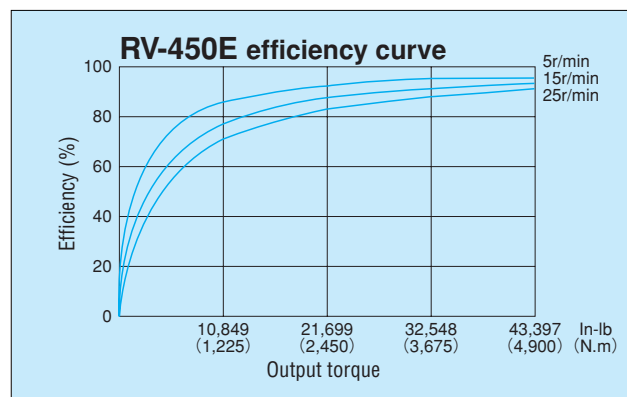
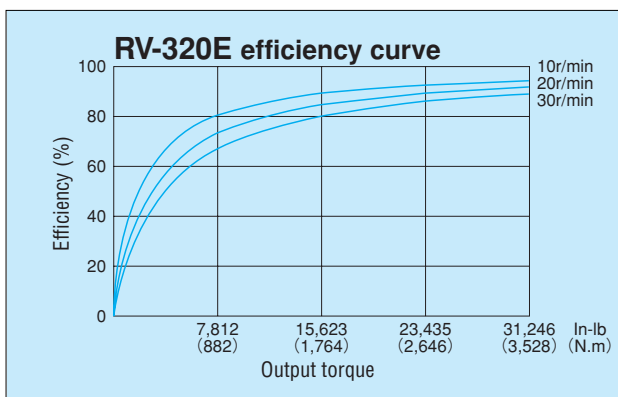
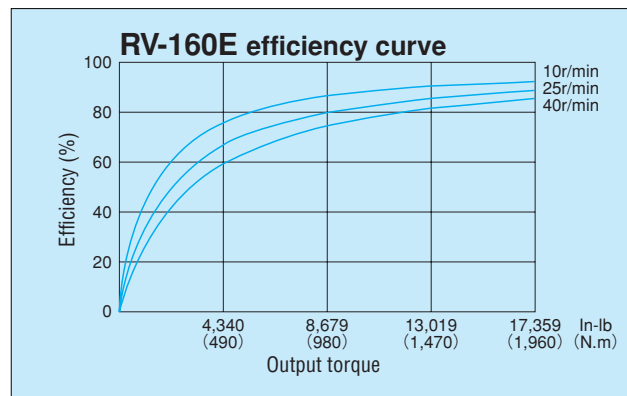
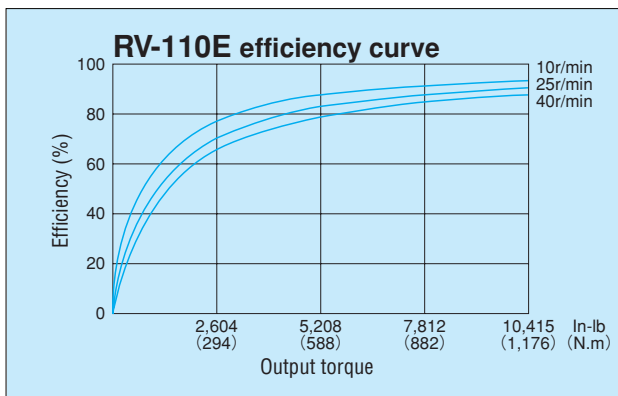
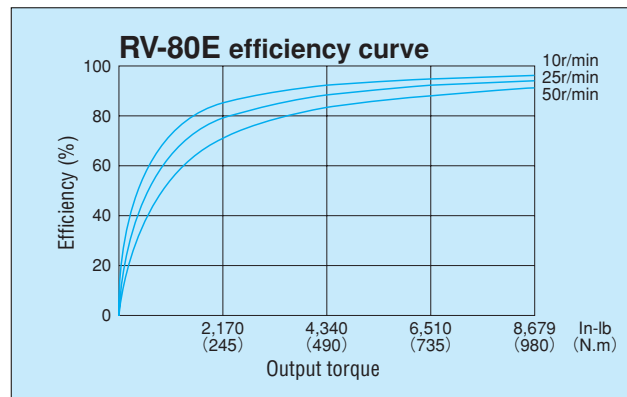
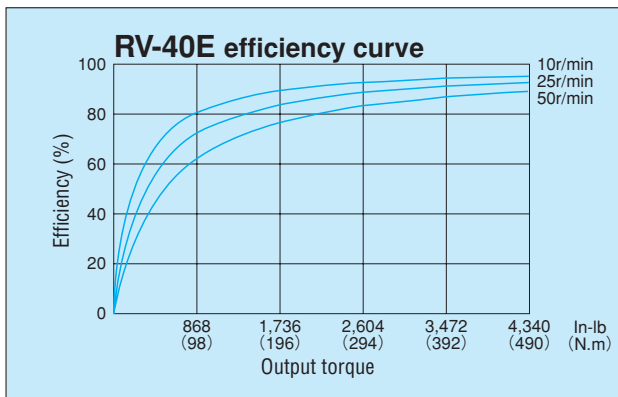
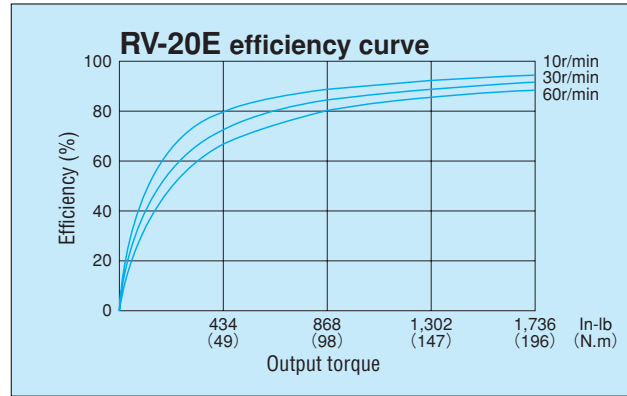
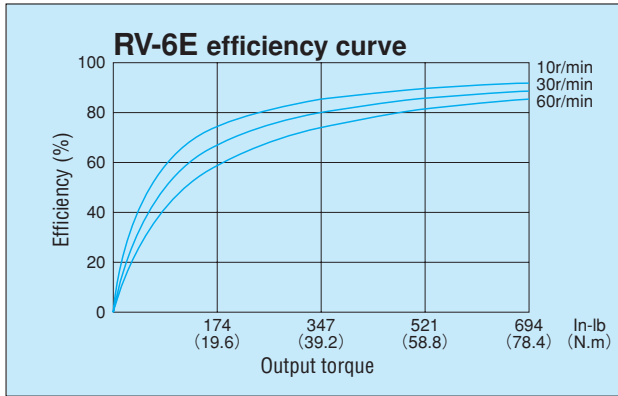

7 INSTALLATION AND ASSEMBLY

To get maximum performance from RV-E reduction gears, it is important to pay attention to the assembly accuracy, installation, lubrication and sealing. Angular ball bearings are used as the main bearings with RV-E Series reduction gears. When designing the layout, make sure the bearing retainer will not touch the motor mounting flange. Refer to the table to the right.

Fig.16

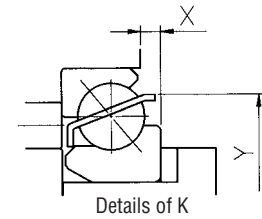

Table 9

(Unit:mm)

	X	Y
RV-6E	MAX1.9	MAX ϕ 85
RV-320E	MAX3.2	MAX ϕ 222.2
RV-450E	MAX5.5	MAX ϕ 285

With other models, the retainer does not stick out from the casing.

7-1 Assembly accuracy

Design motor mounting flange within tolerances shown in Table 10. Poor assembly accuracy causes vibration and noise.

Table 10

Unit: mm

Model	Tolerance for concentricity		Type	Concentricity tolerance
	a	Type		a
RV-6E	MAX0.03	RV-110E	MAX0.03	
RV-20E	MAX0.03	RV-160E	MAX0.05	
RV-40E	MAX0.03	RV-320E	MAX0.05	
RV-80E	MAX0.03	RV-450E	MAX0.05	

Fig.17

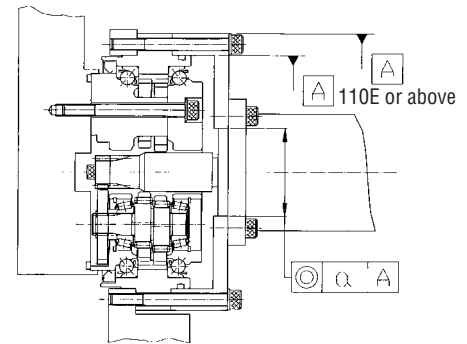

7-2 Installation Procedure

- Typical installation examples for RV-E reduction gear are shown below. Be sure to seal the designated type of grease to the designated level. (See page 29)
- Be sure that seals are used between mating parts on the input side. Refer to the O-ring seal installation illustrated.
- If the use of an O-ring seal is impossible because of the design, use Gasket sealant shown in table 11.
- Use either outer or inner centering locations for piloting.

Table 11 Recommended Gasket sealant

Manufacturer	Name
Loctite	5699 Grey High Performance RTV Silicone Gasket Maker
Permatex	Moto Seal 2 Ultimate Gasket Maker White

Notes 1. Do not use these sealants for copper material or copper alloy material.

2. If these sealants need to be used under special conditions such as concentrated alkali, pressurized steam, etc., please contact Nabtesco.

7-2-1 Bolt clamping output shaft type

Note: The sizes of bolts for tightening the output shaft are not all the same. Make sure that each bolt is tightened with the specified torque after assembling.

Fig.18

Assembly example

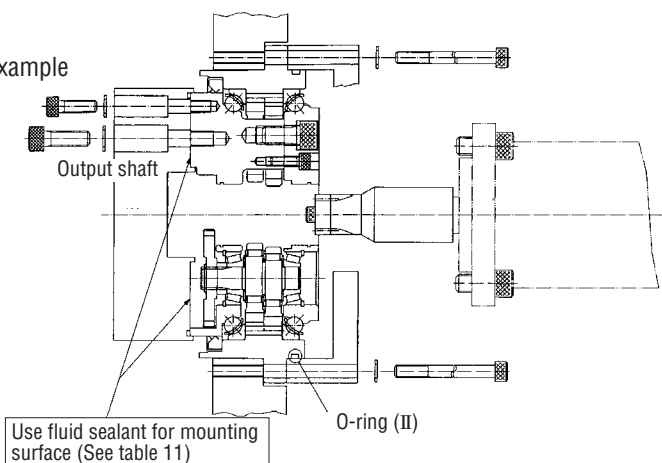

Table 12 Applicable O-ring (II) seal

	Applicable O-ring seal
RV-6E	S100(Metric)
RV-20E	S120(Metric)
RV-40E	AS568-258
RV-80E	AS568-263
RV-110E	G190(Metric)
RV-160E	G220(Metric)
RV-320E	G270(Metric)
RV-450E	G300(Metric)

7-2-2 Pin/bolt clamping output shaft type

Note: The prepared pinhole and the output shaft need to be reamed jointly with a reamer before knocking in the taper pin.
The reduction gear needs to be appropriately covered during reaming to prevent chips from entering inside.

Installation of RV-20E, 40E

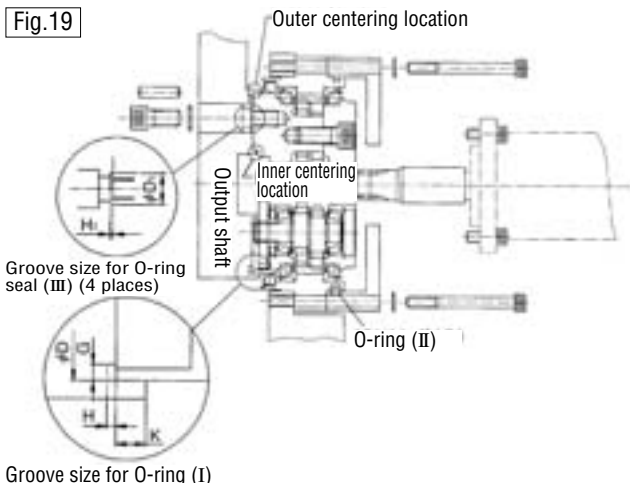

Groove size for O-ring (I)

Installation of RV-160E,320E,450E

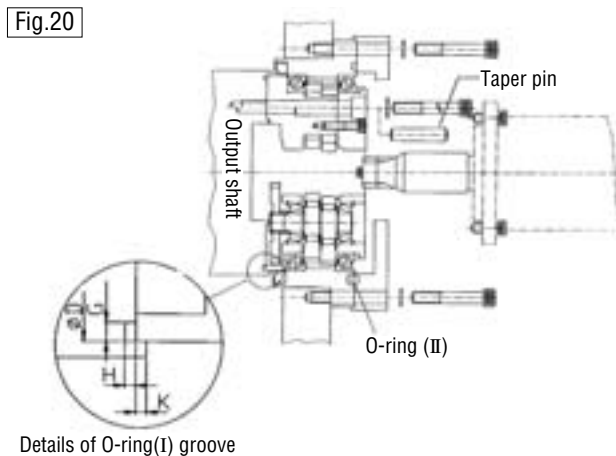

Details of O-ring(I) groove

Installation example for RV-80E

A different method is used on RV-80E to knock in the taper pin, so follow the next procedure for assembling.

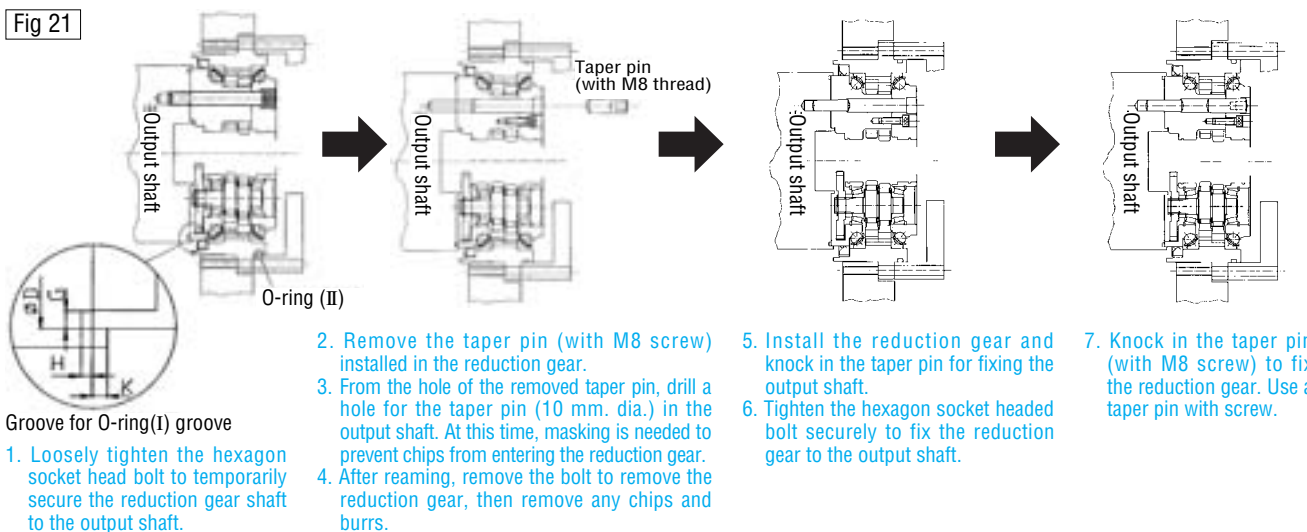

Groove for O-ring(I) groove

1. Loosely tighten the hexagon socket head bolt to temporarily secure the reduction gear shaft to the output shaft.

2. Remove the taper pin (with M8 screw) installed in the reduction gear.
3. From the hole of the removed taper pin, drill a hole for the taper pin (10 mm. dia.) in the output shaft. At this time, masking is needed to prevent chips from entering the reduction gear.
4. After reaming, remove the bolt to remove the reduction gear, then remove any chips and burrs.

5. Install the reduction gear and knock in the taper pin for fixing the output shaft.
6. Tighten the hexagon socket head bolt securely to fix the reduction gear to the output shaft.

7. Knock in the taper pin (with M8 screw) to fix the reduction gear. Use a taper pin with screw.

Table 13 Dimensions for O-ring (I) seal

(Unit:mm)

		For RV-20E(A)	For RV-20E(B)	For RV-40E	For RV-80E	For RV-160E	For RV-320E	For RV-450E	
Dimensions	O-ring	ID No.	AS568-045	S100(Metric)	S132(Metric)	AS568-163	AS568-265	AS568-271	AS568-275
		Wire dia.	ϕ 1.78 \pm 0.07	ϕ 2.0 \pm 0.1	ϕ 2.0 \pm 0.1	ϕ 2.62 \pm 0.07	ϕ 3.53 \pm 0.1	ϕ 3.53 \pm 0.1	ϕ 3.53 \pm 0.1
		I. D.	ϕ 101.32 \pm 0.38	ϕ 99.5 \pm 0.4	ϕ 131.5 \pm 0.6	ϕ 152.07 \pm 0.58	ϕ 196.44 \pm 0.76	ϕ 234.54 \pm 0.76	ϕ 266.29 \pm 0.76
	Groove size	Outside dia. D O. D. D.	ϕ 105	ϕ 105	ϕ 135	ϕ 160	ϕ 204	ϕ 243	ϕ 273
		Depth: H	1.27 \pm 0.05	1.5 $^{0}_{-0.1}$	1.5 $^{0}_{-0.1}$	2.06 \pm 0.05	2.82 \pm 0.05	2.82 \pm 0.05	2.82 \pm 0.05
	Width: G	2.39 $^{+0.25}$	2.7 $^{+0.25}$	2.7 $^{+0.25}$	3.58 $^{+0.25}$	4.78 $^{+0.25}$	4.78 $^{+0.25}$	4.78 $^{+0.25}$	
	Height :K (For reference)	3	3	3	3	4	4	4	

Table 14 O-ring (II) seal dimensions

(Unit:mm)

	For RV-20E	For RV-40E	For RV-80E	For RV-160E	For RV-320E	For RV-450E
ID No.	S120(Metric)	AS568-258	AS568-263	G220(Metric)	G270(Metric)	G300(Metric)

Table 15 Dimensions for O-ring (III) seal

(Unit:mm)

		For RV-20E	For RV-40E	
Dimensions	O-ring	ID No.	S12.5(Metric)	S14(Metric)
		Wire dia.	ϕ 1.5 \pm 0.1	ϕ 1.5 \pm 0.1
		I. D.	ϕ 12	ϕ 13.5
	Groove dimensions	Outside dia. D O. D. D.	ϕ 14.8 \pm 0.1	ϕ 16.3 \pm 0.1
		Depth: H	1 $^{0}_{-0.1}$	1 $^{0}_{-0.1}$

Notes 1. Use O-ring seal of either type (A) or type (B). (Both of them are available)
2. "G", "S" part numbers are Japanese Industrial Standard(JIS B 2401)Metric O-rings.

7-3 Bolt tightening torque and allowable transmission torque

Use hexagonal socket bolts to assemble the RV-E reduction gear and tighten to the torque as specified below. When the pin/bolt mounting output shaft type is used, also use the taper pin. The serrated lock washer is recommended to prevent the bolt from loosening and protect the bolt seat face from flaws.

Table 16 Tightening force (F)

Hexagonal socket bolt nominal size x pitch (mm)	Tightening torque In-lb(Nm)	Tightening force (F) N	Bolt specification
M5 ×0.8	80 ±4 (9.01 ±0.49)	9,310	<ul style="list-style-type: none"> ● Hexagonal socket bolt JIS B 1176 ● Strength class JIS B 1051 12.9 ● Thread JIS B 0205 6g or class 2
M6 ×1.0	138 ±7 (15.6 ±0.78)	13,180	
M8 ×1.25	329 ±16 (37.2 ±1.86)	23,960	
M10×1.5	651 ±30 (73.5 ±3.43)	38,080	
M12×1.75	1,137 ±56 (128.4 ±6.37)	55,100	
M14×2.0	1,814 ±90 (204.8 ±10.2)	75,860	
M16×2.0	2,821 ±141 (318.5 ±15.9)	103,410	

Notes 1. The valves listed are for steel or cast iron material.

2. If softer material such as aluminum is used, limit the tightening torque. Also pay attention to the system torque requirements.

Calculation of allowable transmission torque of bolts

$$T_1 = F \times \frac{D_1}{2} \times \mu \times n_1$$

T_1 : bolt allowable transmission torque (Nm)
 F : bolt tightening force (N)
 D_1 : bolt P.C.D. (m)
 μ : friction factor
 $\mu = 0.15$: where lubricants remained
 $\mu = 0.2$: where left dried with no lubricant
 n_1 : number of bolts

Calculation of allowable transmission torque of bolt and additional pin(s)

$$T_2 = T_1 + \frac{\pi d^2}{4} \times \tau \times \frac{D_2}{2} \times n_2$$

T_2 : allowable transmission torque of bolt and additional pin (Nm)
 d : pin diameter (mm)
 τ : pin allowable shearing strength (N/mm²)
 [$\tau = 196$: pin material S45C-Q]
 D_2 : pin P.C.D. (m)
 n_2 : number of pins

Serrated lock washer external teeth for hexagonal socket bolt

Material: Steel
Hardness: HRC40~48

Fig.22

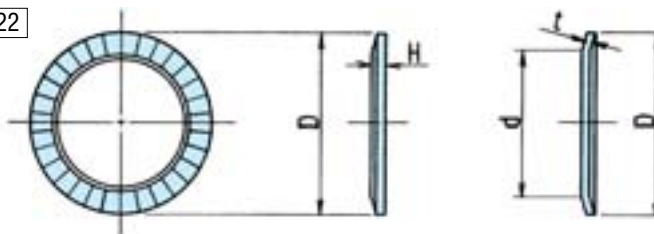

Table 17

(Unit:mm)

Nominal size	ID and OD of washer		t	H
	d	D		
	Basic size			
5	5.25	8.5	0.6	0.85
6	6.4	10	1.0	1.25
8	8.4	13	1.2	1.55
10	10.6	16	1.5	1.9
12	12.6	18	1.8	2.2
14	14.6	21	2.0	2.5
16	16.9	24	2.3	2.8

Note: When using any equivalent washer, select it, with special care given to its outside diameter.

7-4 Installation of input gear

- The standard-sized input gear comes from the factory without holes drilled for motor shafts.
- The following are reference drawings for installation of input shafts. Customers must provide set screw, hexagonal socket bolt, or hexagonal nut and draw bolt. Some low ratio input gears will not fit through the center of the RV gear. See 7-4-3.

Fig.23

Straight shaft

No female threaded on servomotor

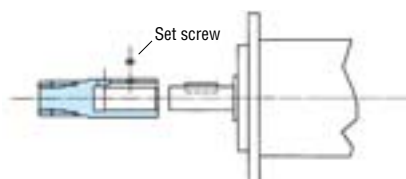

With female threaded on servomotor

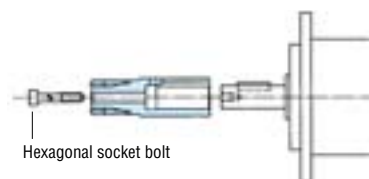

Taper shaft

With male threaded on servomotor

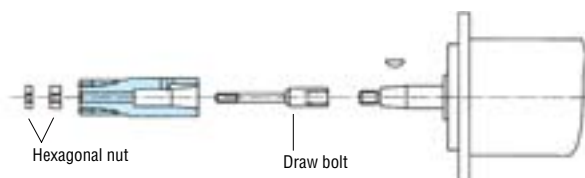

7-4-1 Precautions for installation of RV-6E, 20E and 40E input gears

RV-6E, RV-20E and RV-40E have two spur gears. Special care must be used when installing the input gear to prevent misalignment.

Insert the input gear. If the input gear does not engage with the spur gear, insert the input gear by turning it clockwise or counterclockwise a little. Make sure that the motor flange is fitted closely and squarely. Do not tighten motor with screws unless the motor is properly aligned. If the motor flange is at an angle, there is a possibility that the input gear is installed in an incorrect position. (See Fig. 24)

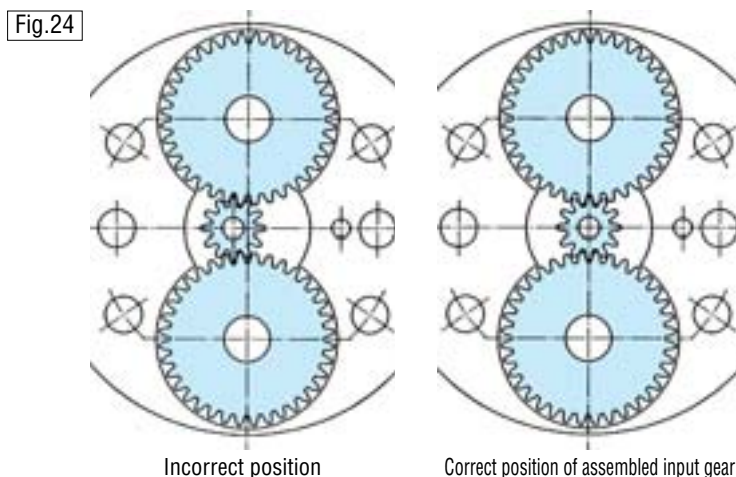

7-4-2 Pass-through capacity of input gear

Lower ratio input gears may have diameters too large to pass through the RV gear center. The following table shows which ratios can and can not allow the input gear to pass through.

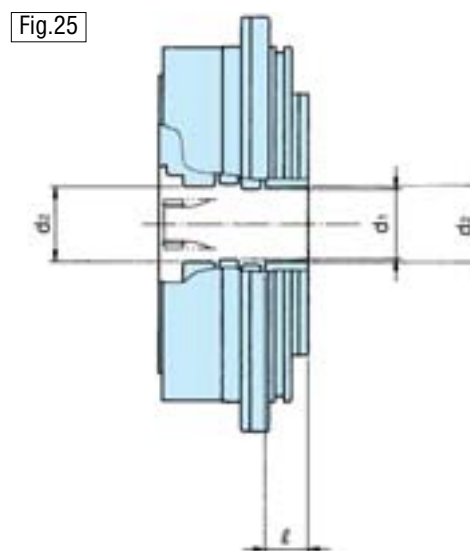

Table 18

(Unit:mm)

Model	Hole dia.		Depth l	Speed ratio adequate for shaft passage		Speed ratio inadequate for shaft passage	
	d_1	d_2		Shaft revolution	Case revolution	Shaft revolution	Case revolution
RV-6E	19	21	18	53.5, 59, 79, 103	52.5, 58, 78, 102	31, 43	30, 42
RV-20E	22	24	18.5	81, 105, 121, 141	80, 104, 120, 140	57	56
RV-40E	27	30	23.5	81, 105, 121, 153	80, 104, 120, 152	57	56
RV-80E	37	40	23	81, 101, 121, 153	80, 100, 120, 152	57	56
RV-110E	39	42	20	81, 111, 127.7 161, 175.2	80, 110, 126.7 160, 174.2	—	—
RV-160E	43	47	30	81, 101, 129 145, 171	80, 100, 128 144, 170	* 66	* 65
RV-320E	47	52	35.5	81, 101, 118.5 129, 141, 171, 185	80, 100, 117.5 128, 140, 170, 184	* 66	* 65
RV-450E	57	62	43	81, 101, 118.5 129, 155, 171, 192	80, 100, 117.5 128, 154, 170, 191	* 66	* 65

* Not described on the rating table. Please consult Nabtesco if needed.

7-4-3 An example of installation for the reduction gear with lower speed ratio

The lower the speed ratio, the larger the outside diameter of the input gear. Therefore, the installation of the input gear through the reduction gear is not possible with all ratios. In such cases a two-piece input gear is required. An example is shown below:

Fig.26

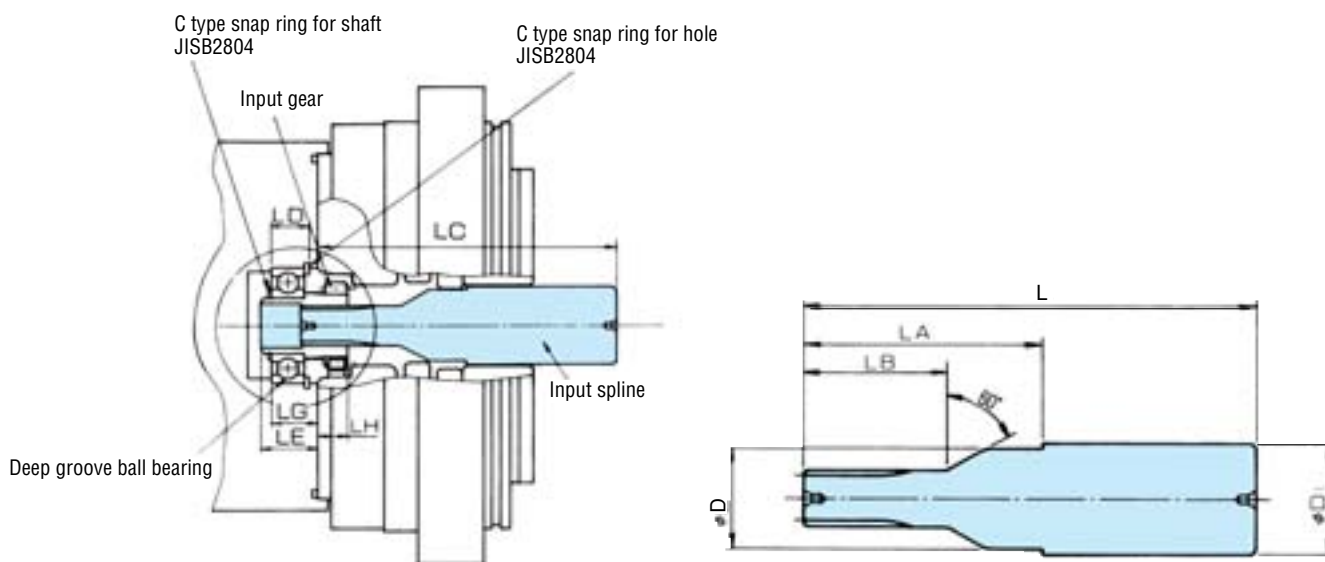

Table 19

(Unit:mm)

Model	L	LA	LB	D	D ₁	LC	LD ^{+0.1}	LE	LG ^{±0.1}	LH	Deep groove ball bearing
RV-6E	96	58	23	18	28	92	10.3	16	13	7.5	6,002
RV-20E	95	53	30	21.5	23.5	90	11.7	17	14	9	6,003
RV-40E	105	58	30	26.5	29.5	103	13.9	19	16	11.5	6,004
RV-80E*1	110	—	35	36	36	109	13.9	15.5	12	16	6,005
RV-80E*2	110	—	35	36	36	105	13.9	19.5	16	12	6,005
RV-160E	130	—	38	42	42	128	15.1	21	17	16	6,006
RV-320E	155	—	48	46	46	148	16.1	22	18	20	6,007
RV-450E	200	—	48	56	56	195	17.6	26	22.5	21	6,008

Note: Deep groove ball bearing and C-shaped snap rings are to be provided by the customer.

*1: Bolt mounting output shaft type

*2: Pin/bolt mounting output shaft type

7-5 Lubrication

To maximize the performance of the RV-E reduction gear, the use of Molywhite RE00 manufactured by Nabtesco is recommended.

7-5-1 Grease lubrication

The standard lubrication of RV-E is grease.

Table 20 Brand of recommended lubricant

Grease	
Nabtesco	Molywhite RE00

Note: Do not mix the recommended grease or gear oil with any other lubricant.

Table 21 Working temperature range (ambient temperature)

Working temperature range (ambient temperature)	-10°C ~ 40°C
---	--------------

Note: Please consult Nabtesco if grease or gear oil is to be used beyond the specified temperature range.

1) The quantity of grease required for the RV-E reduction gear

The RV-E reduction gear is not greased when it is shipped from the plant. Therefore, the user must ensure that necessary amount of recommended grease is charged when installing the RV-E reduction gear.

Note: Table 22 and 23 shows the quantities of grease required for each type of RV-E reduction gear. However, the quantities do not include the space between the reduction gear and mating components. Therefore, if there are some, they must be charged also.

However, too much filling may causes damage for an oil seal with increase of internal pressure. Please leave about 10% of the room inside.

Table 22 Horizontal installation

Type	Quantity	
	cc	(g)
RV-6E	42	(37)
RV-20E	87	(76)
RV-40E	195	(170)
RV-80E (Bolt clamping)	383	(333)
RV-80E (Pin/bolt clamping)	345	(300)
RV-110E	432	(376)
RV-160E	630	(548)
RV-320E	1,040	(905)
RV-450E	1,596	(1,389)

Table 23 Vertical installation

Type	Quantity	
	cc	(g)
RV-6E	48	(42)
RV-20E	100	(87)
RV-40E	224	(178)
RV-80E (Bolt clamping)	439	(382)
RV-80E (Pin/bolt clamping)	396	(345)
RV-110E	495	(431)
RV-160E	694	(604)
RV-320E	1,193	(1,038)
RV-450E	1,831	(1,593)

2) Grease (gear oil) level in RV-E reduction gear

Fig.27

Horizontal installation

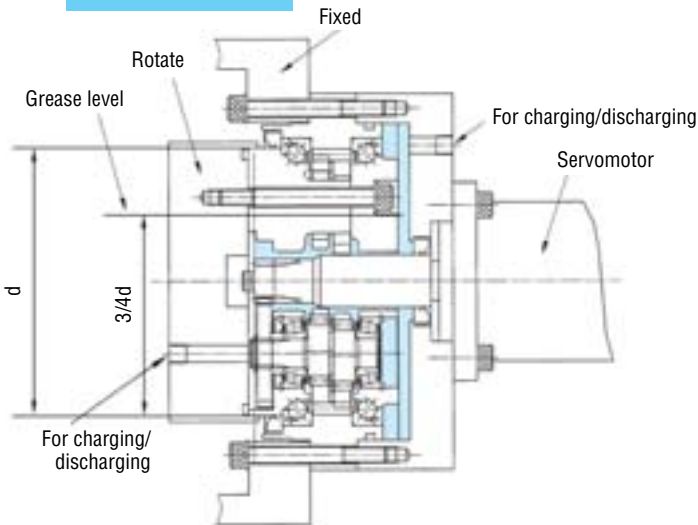

Vertical installation (1)

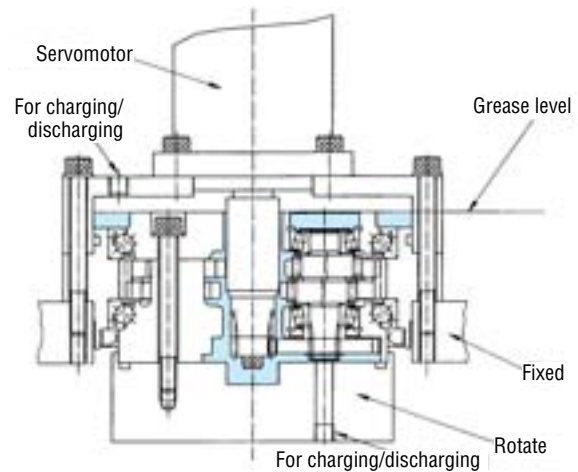

Vertical installation (2)

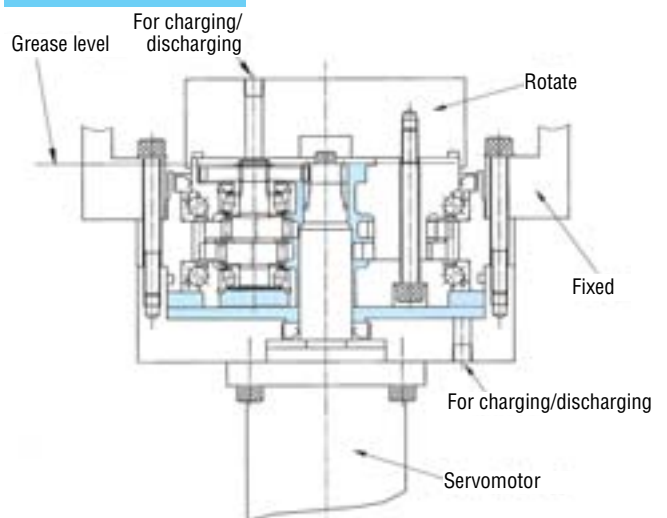

3) Interval between grease changes

Change grease at a standard interval of 20,000 hours after initially supplying the RV-E reduction gear with grease in the specified quantity (see Fig.27) in order to protect the RV-E reduction gear from deteriorated grease.

If grease is contaminated for any reason or used at an ambient temperature of 40°C or more, check the grease for contamination and deterioration, to determine the proper maintenance interval.

7-6 Warranty

Nabtesco guarantees that the reduction gears of the model RV are free from defects of materials and workmanship.

The term of guarantee shall be one year after delivery or 2,000 hours of operation after the installation on an actual machine, whichever earlier, on condition that the product is operated under the rated operation conditions specified by us, in normal assembly and lubrication condition.

If any defect in materials or workmanship is detected during the above guarantee term, the product will be repaired or substituted at our expense, provided that the No. of man-hour required for demounting and remounting the product from the machine, transportation expense for re-delivery, warehousing and other incidental expenses shall be excluded from our obligation.

No expenses for damages of the machine due to shutdown of operation attributable to defect of the product are guaranteed.

If the guarantee is accomplished with money, the upper limit of the amount shall not exceed the selling price of that claimed product.

8 External dimensions

8-1 RV-6E External dimensions of bolt clamping output shaft type (2 piece input gear)

Speed ratio
Type code RV-6E-□-A-□-B

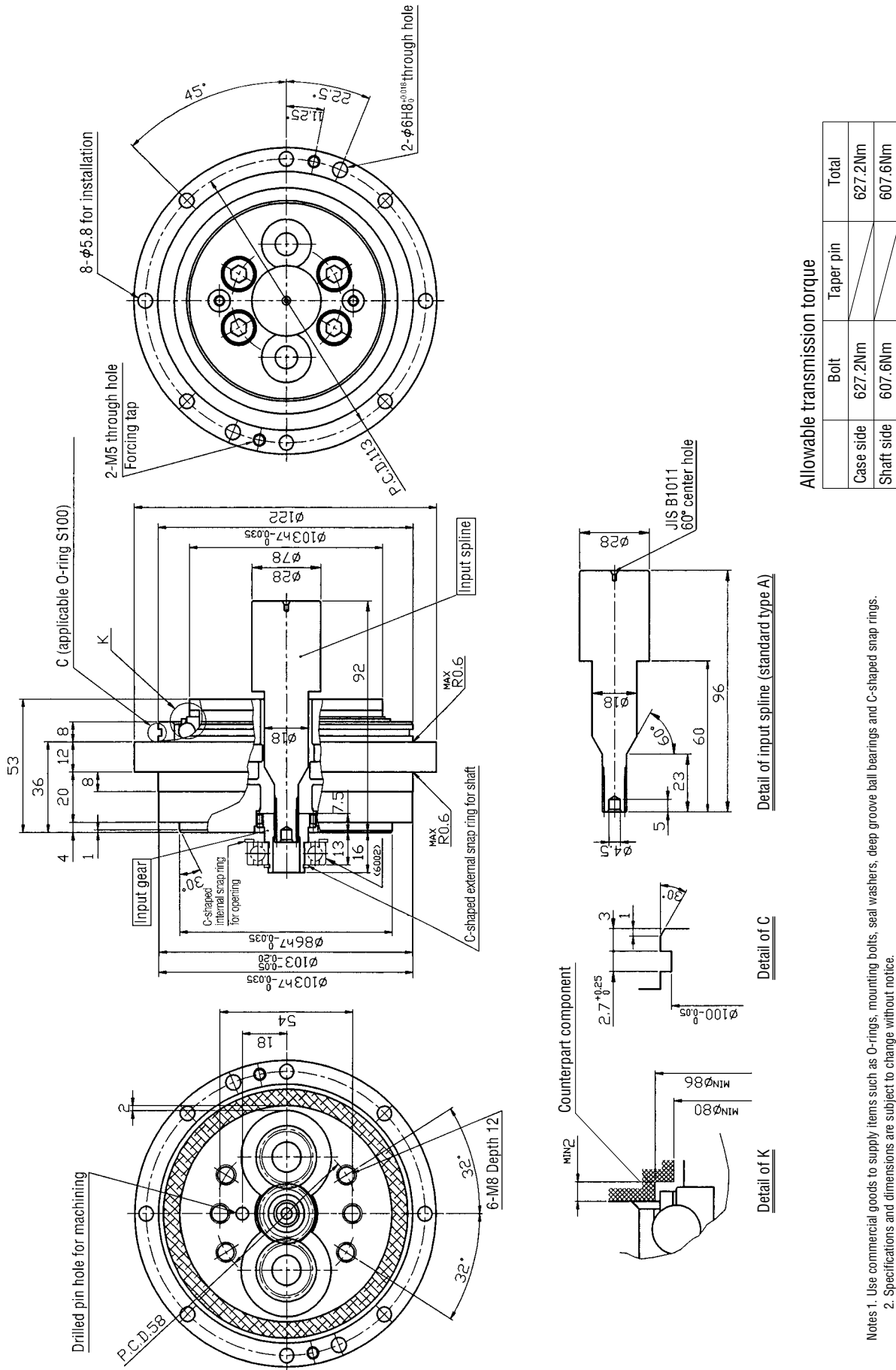

Allowable transmission torque

	Bolt	Taper pin	Total
Case side	627.2Nm		627.2Nm
Shaft side	607.6Nm		607.6Nm

Notes 1. Use commercial goods to supply items such as O-rings, mounting bolts, seal washers, deep groove ball bearings and C-shaped snap rings.
2. Specifications and dimensions are subject to change without notice.

8-2 RV-6E External dimensions of bolt clamping output shaft type (1 piece input gear)

Speed ratio

Type code RV-6E-□-A-B

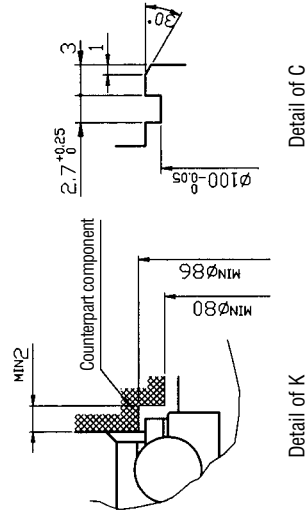
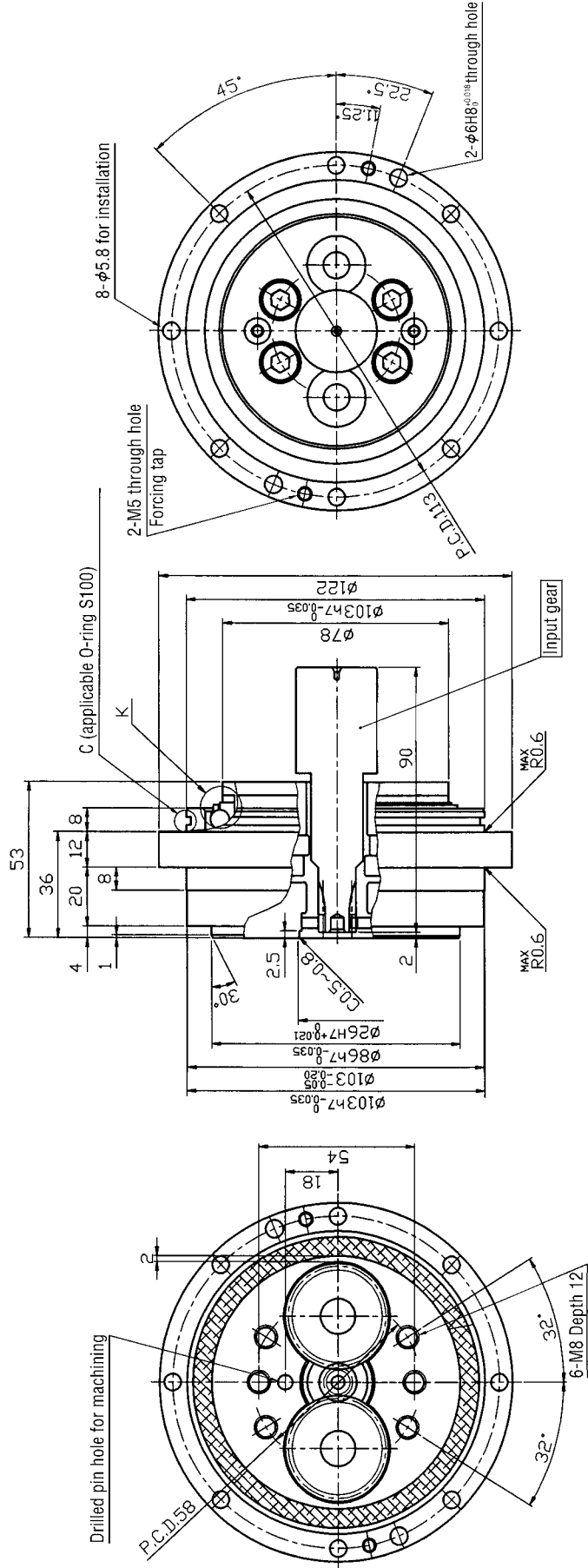

Detail of K

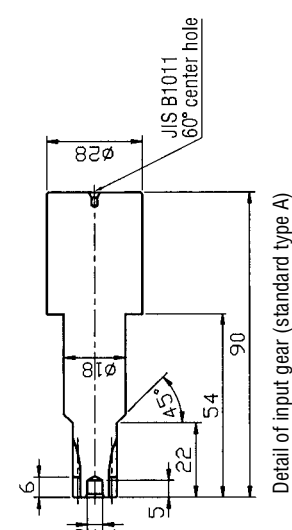

Detail of input gear (standard type A)

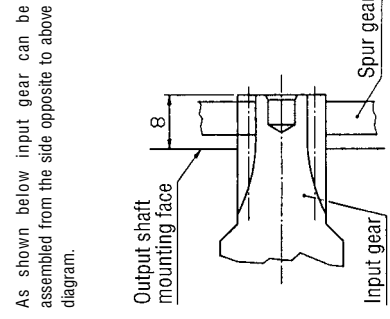

As shown below input gear can be assembled from the side opposite to above diagram.

Allowable transmission torque

Bolt	Taper pin	Total
Case side	627.2Nm	627.2Nm
Shaft side	607.6Nm	607.6Nm

Notes 1. Use commercial goods to supply items such as O-rings, mounting bolts and seal washers
2. Specifications and dimensions are subject to change without notice.

8-3 RV-20E External dimensions of bolt clamping output shaft type (2 piece input gear) Speed ratio $\frac{A}{B}$ Type code RV-20E-57- $\frac{A}{B}$ -B

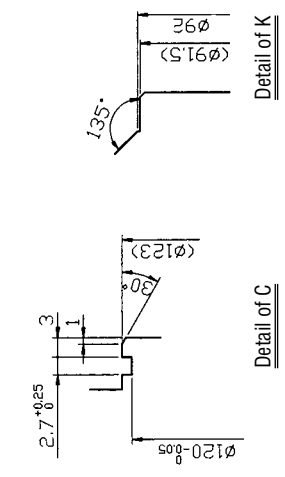
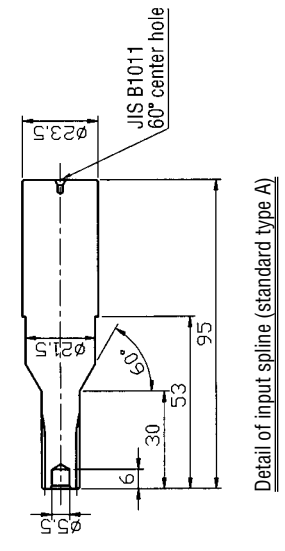
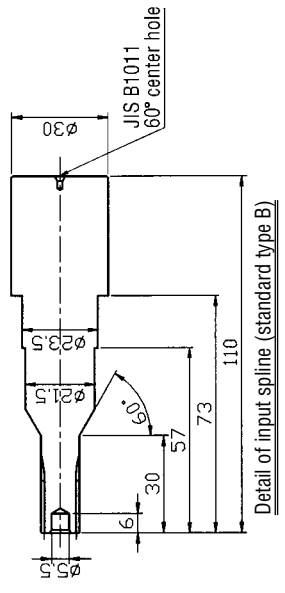
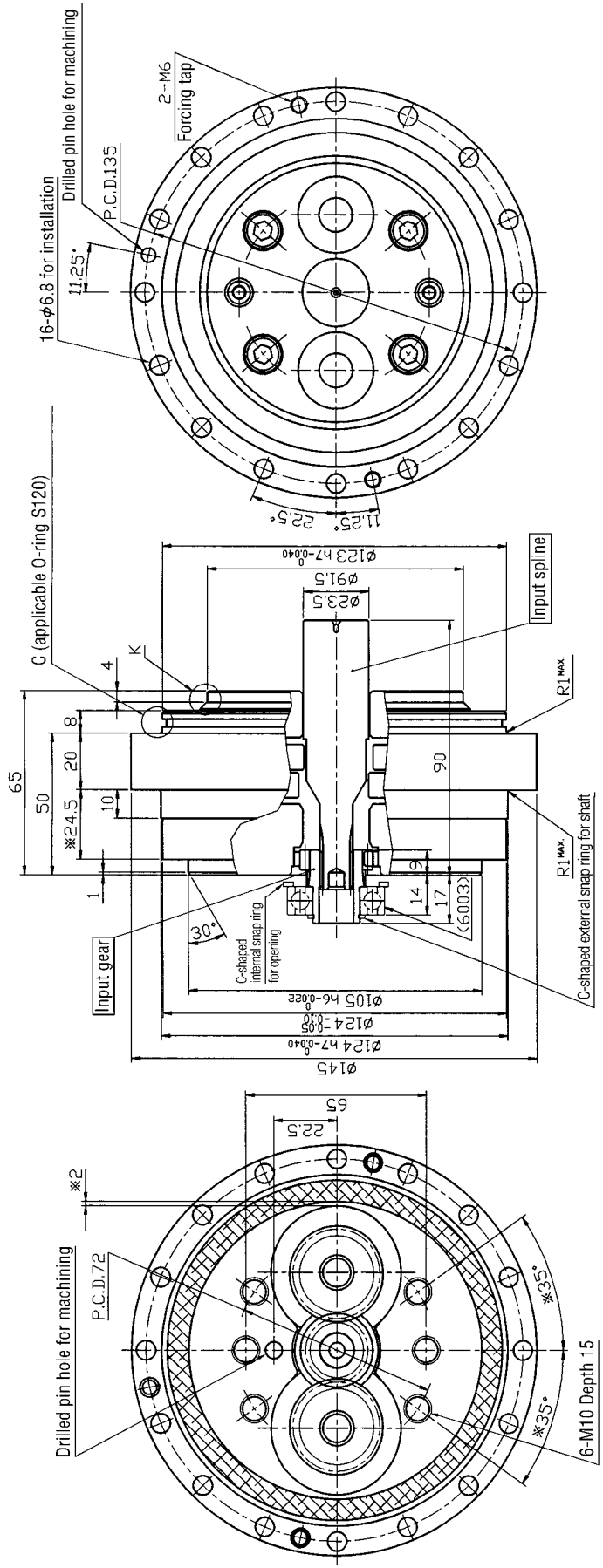

Allowable transmission torque

	Bolt	Taper pin	Total
Case side	2,136.4Nm		2,136.4Nm
Shaft side	1,195.6Nm		1,195.6Nm

Notes 1. Values marked by asterisk (*) differ from RV-15Al.
 2. Use commercial goods to supply items such as O-rings, mounting bolts, seal washers, deep groove ball bearings and C-shaped snap rings.
 3. Specifications and dimensions are subject to change without notice.

8-4 RV-20E External dimensions of bolt clamping output shaft type (1 piece input gear)

Speed ratio: **RV-20E-A-B**
Type code

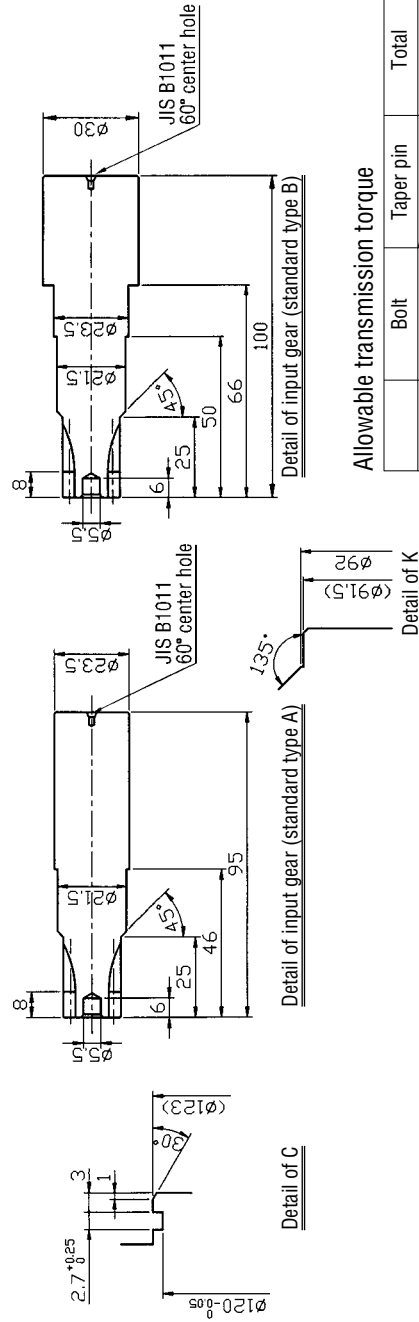
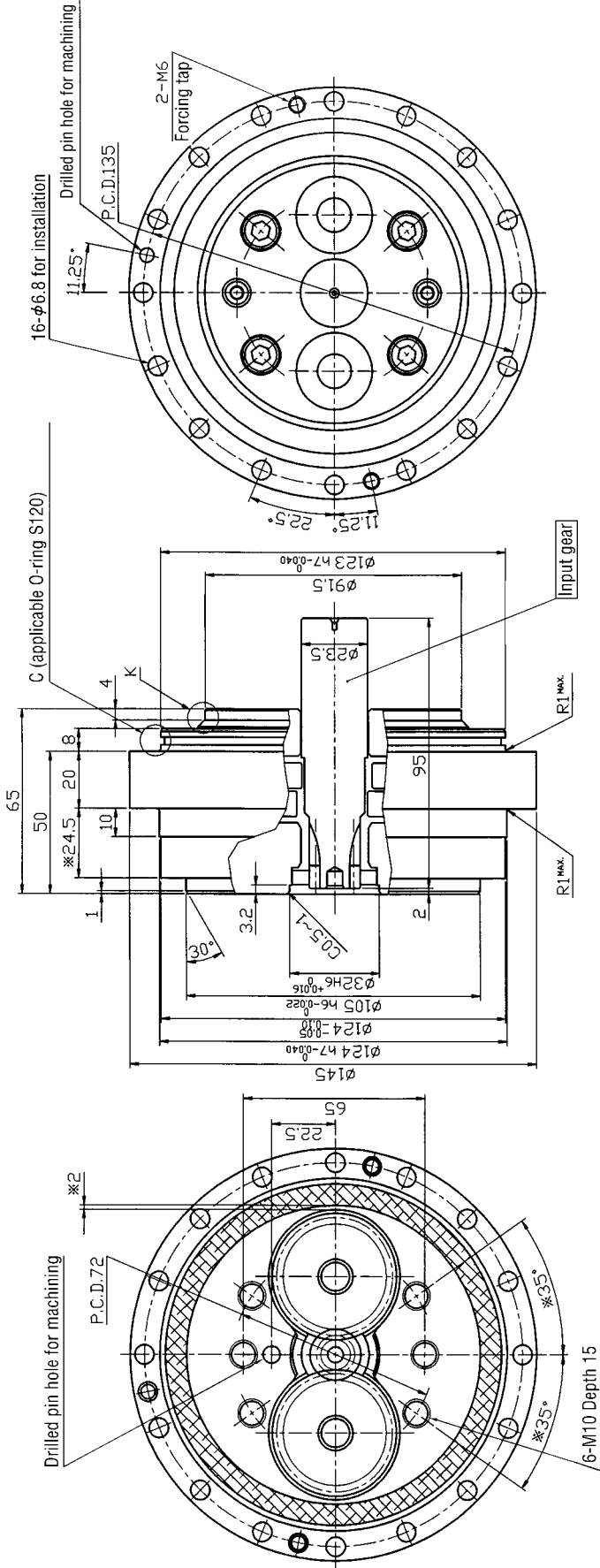

Allowable transmission torque

	Bolt	Taper pin	Total
Case side	2,136.4Nm		2,136.4Nm
Shaft side	1,195.6Nm		1,195.6Nm

As shown below input gear can be assembled from the side opposite to above diagram.

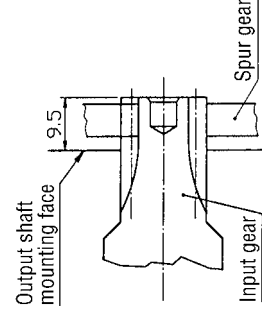

- Notes 1. Values marked by asterisk (*) differ from RV-15AII.
- 2. Use commercial goods to supply items such as O-rings, mounting bolts and seal washers.
- 3. Specifications and dimensions are subject to change without notice.

8-5 RV-40E External dimensions of bolt clamping output shaft type (2 piece input gear)

Speed ratio $\frac{A}{B}$ Type code RV-40E- $\frac{57}{A}$ - $\frac{B}{B}$

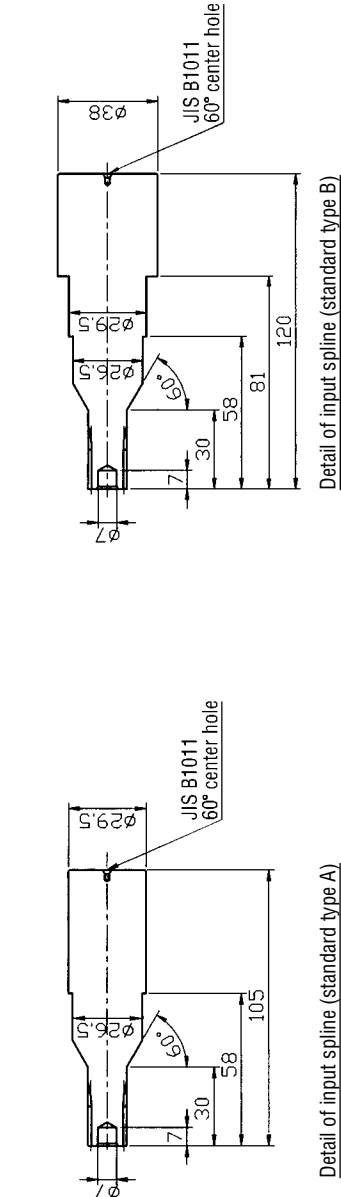
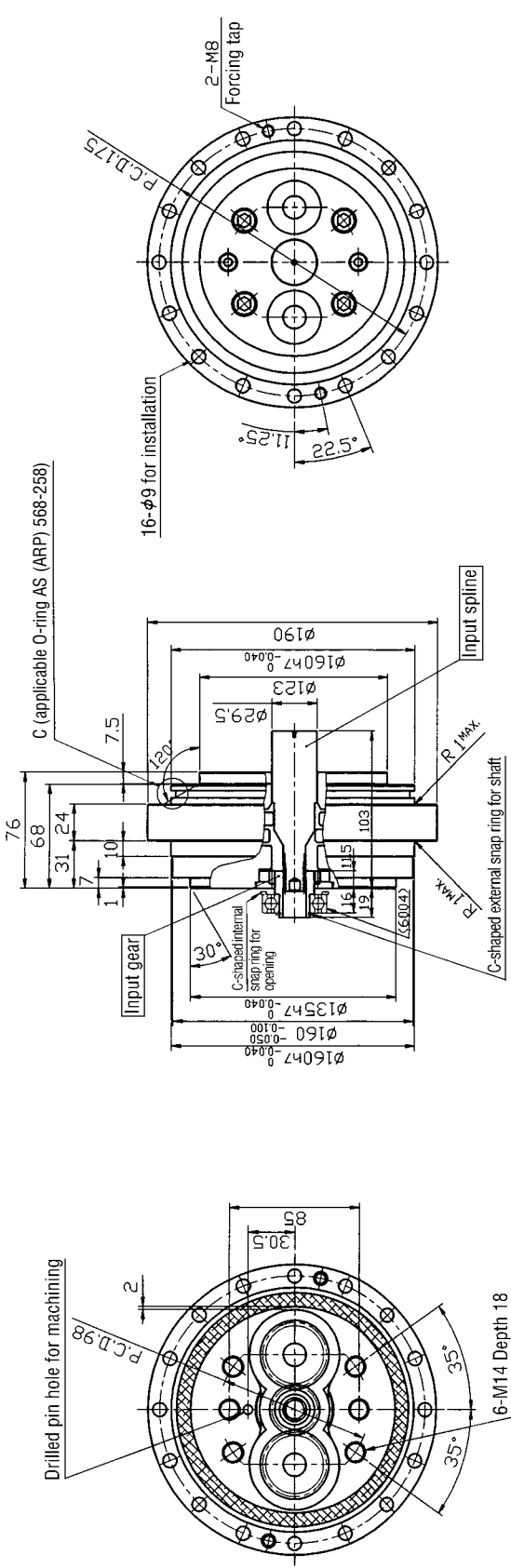

Allowable transmission torque

	Bolt	Taper pin	Total
Case side	5,027.4Nm		5,027.4Nm
Shaft side	3,204.6Nm		3,204.6Nm

Notes 1. Use commercial goods to supply items such as O-rings, mounting bolts, seal washers, deep groove ball bearings and C-shaped snap rings.
 2. Specifications and dimensions are subject to change without notice.

8-7 RV-80E External dimensions of bolt clamping output shaft type (2 piece input gear)

Speed ratio $\frac{A}{B}$ Type code RV-80E- $\frac{57}{B}$ - $\frac{A}{B}$ -B

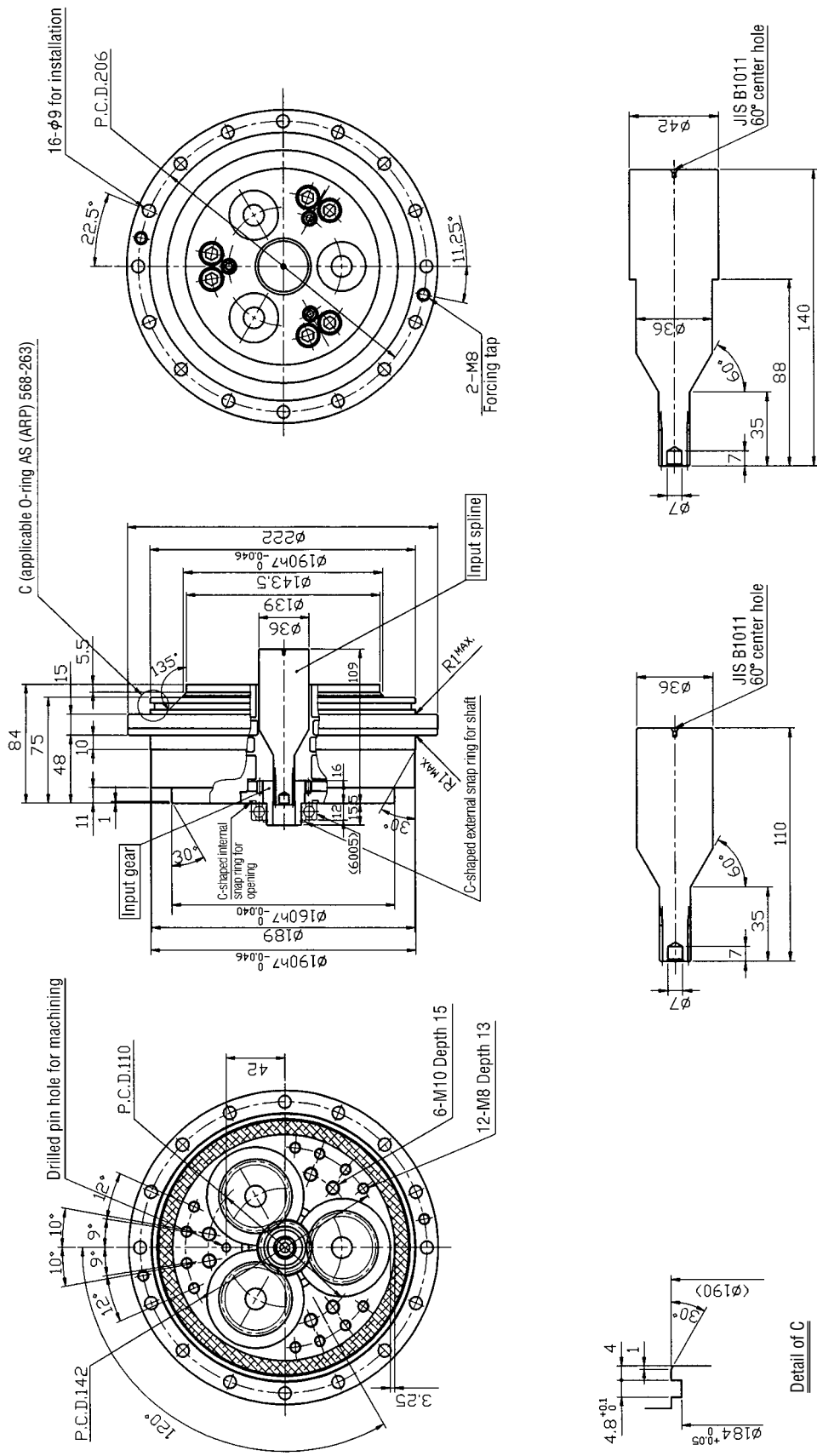

Detail of input spline (standard type A)

Detail of input spline (standard type B)

Allowable transmission torque

	Bolt	Taper pin	Total
Case side	5,919.2Nm		5,919.2Nm
Shaft side	4,939.2Nm		4,939.2Nm

Notes 1. Use commercial goods to supply items such as O-rings, mounting bolts, seal washers, deep groove ball bearings and C-shaped snap rings.
2. Specifications and dimensions are subject to change without notice.

8-8 RV-80E External dimensions of bolt clamping output shaft type (1 piece input gear)

Speed ratio: $\frac{A}{B}$
 Type code RV-80E- \square - $\frac{A}{B}$ -B

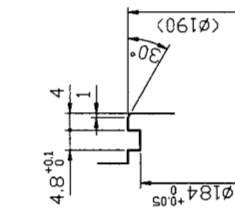
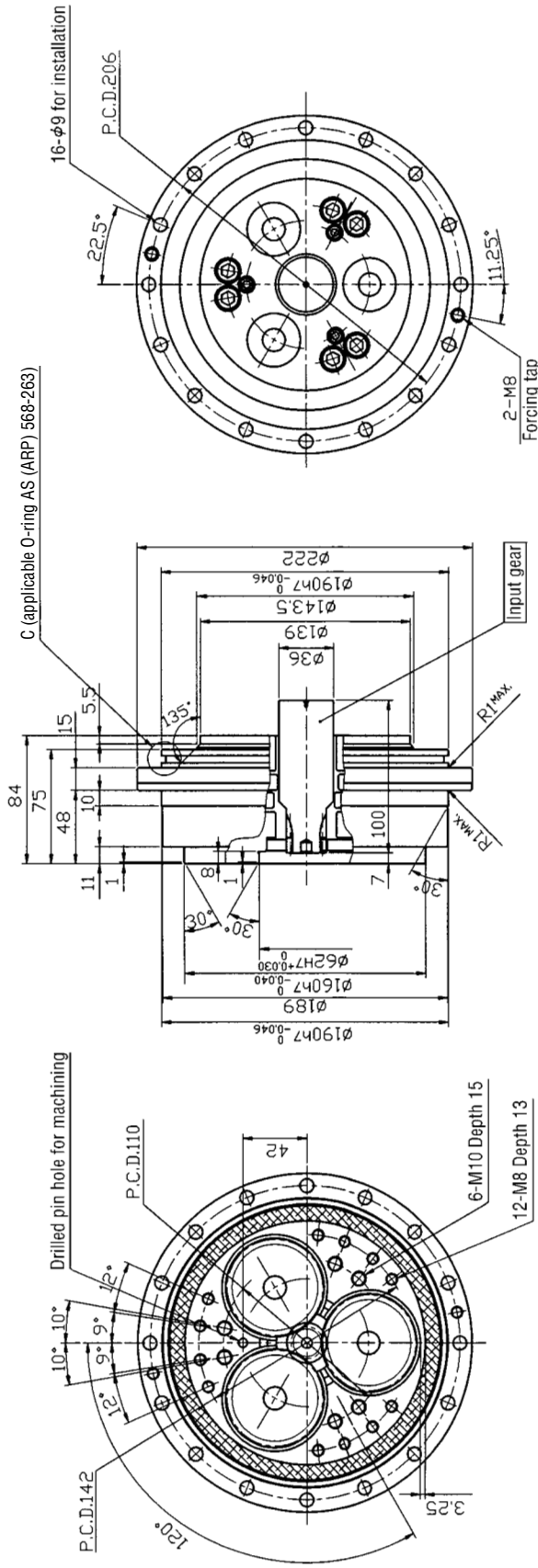

Detail of C

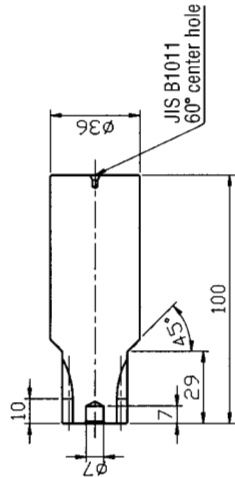

Detail of input gear (standard type A)

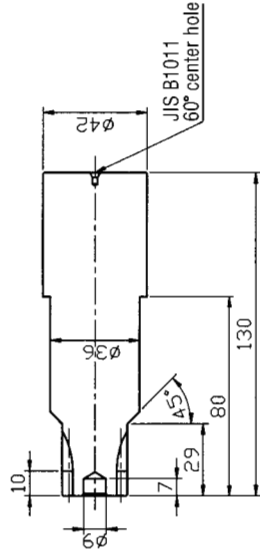

Detail of input gear (standard type B)

As shown below input gear can be assembled from the side opposite to above diagram.

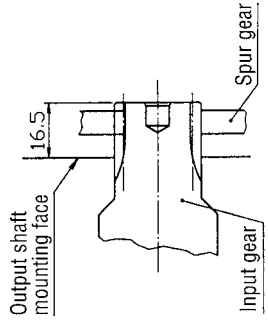

Allowable transmission torque

	Bolt	Taper pin	Total
Case side	5,919.2Nm		5,919.2Nm
Shaft side	4,939.2Nm		4,939.2Nm

Notes 1. Use commercial goods to supply items such as O-rings, mounting bolts and seal washers.
 2. Specifications and dimensions are subject to change without notice.

8-9 RV-110E External dimensions of bolt clamping output shaft type (1 piece input gear) Type code RV-110E-□-A-□-B

Speed ratio

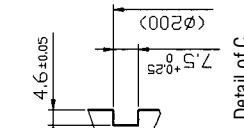
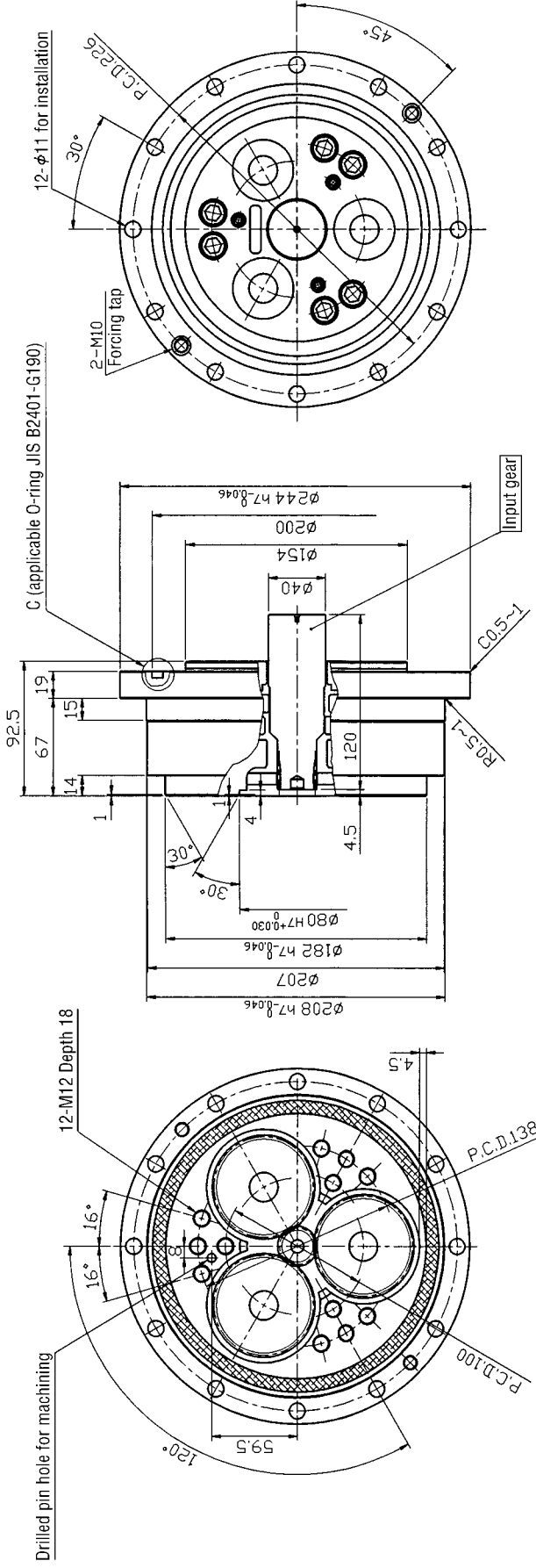

Detail of C

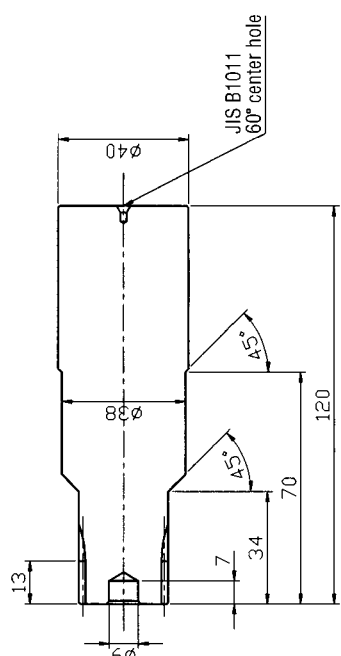

Detail of input gear (standard type A)

As shown below input gear can be assembled from the side opposite to above diagram.

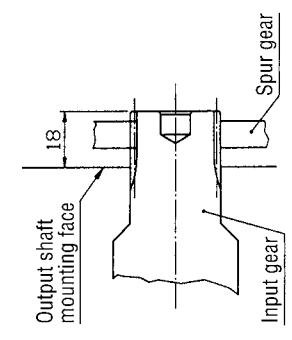

Allowable transmission torque

	Bolt	Taper pin	Total
Case side	7,742Nm	/	7,742Nm
Shaft side	6,370Nm	/	6,370Nm

Notes 1. Use commercial goods to supply items such as O-rings, mounting bolts and seal washers.
 2. Specifications and dimensions are subject to change without notice.

8-10 RV-160E External dimensions of bolt clamping output shaft type (1 piece input gear) Type code RV-160E- - - - -B

Speed ratio

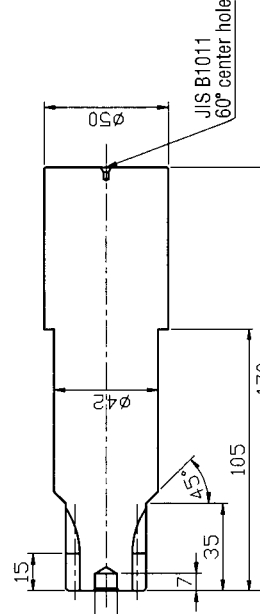
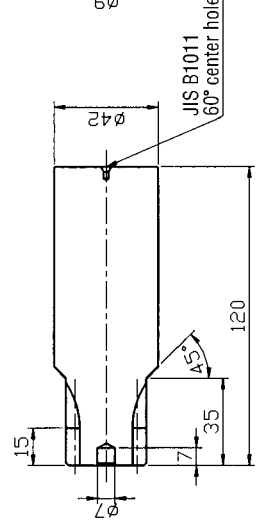
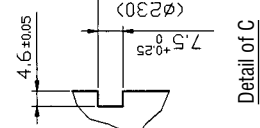
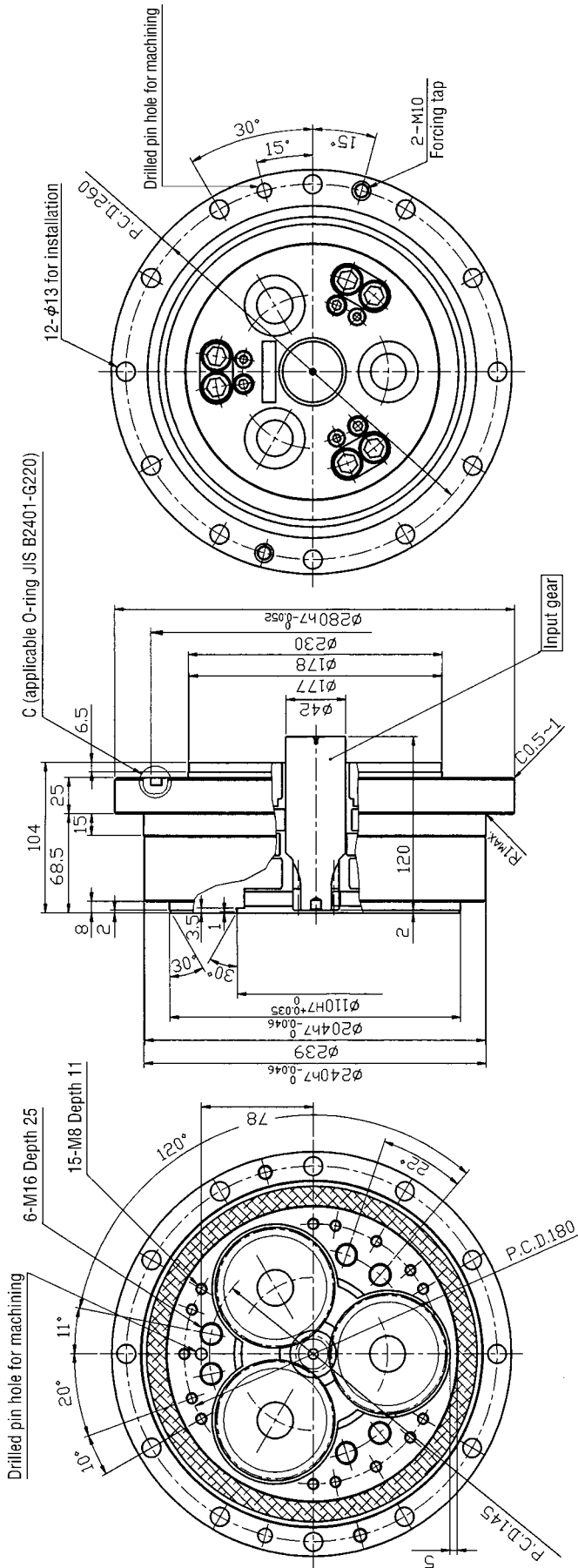

As shown below input gear can be assembled from the side opposite to above diagram.

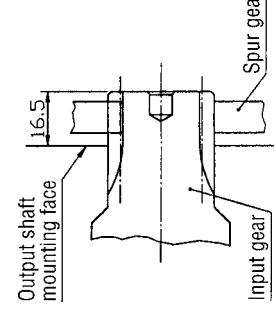

Detail of input gear (standard type A)

Detail of input gear (standard type B)

Allowable transmission torque

		Bolt	Taper pin	Total
Case side		12,887Nm		12,887Nm
Shaft side		11,593.4Nm		11,593.4Nm

- Notes 1. The input gear profile is different when reduction ratio is small ($i=1/66$). Refer to page 27 & 28.
- 2. Use commercial goods to supply items such as O-rings, mounting bolts and seal washers.
- 3. Specifications and dimensions are subject to change without notice.

RV-E series

8-11 RV-320E External dimensions of bolt clamping output shaft type (1 piece input gear) Type code RV-320E-□-□-A-B

Speed ratio

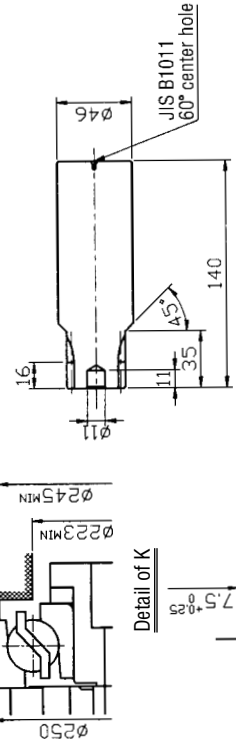
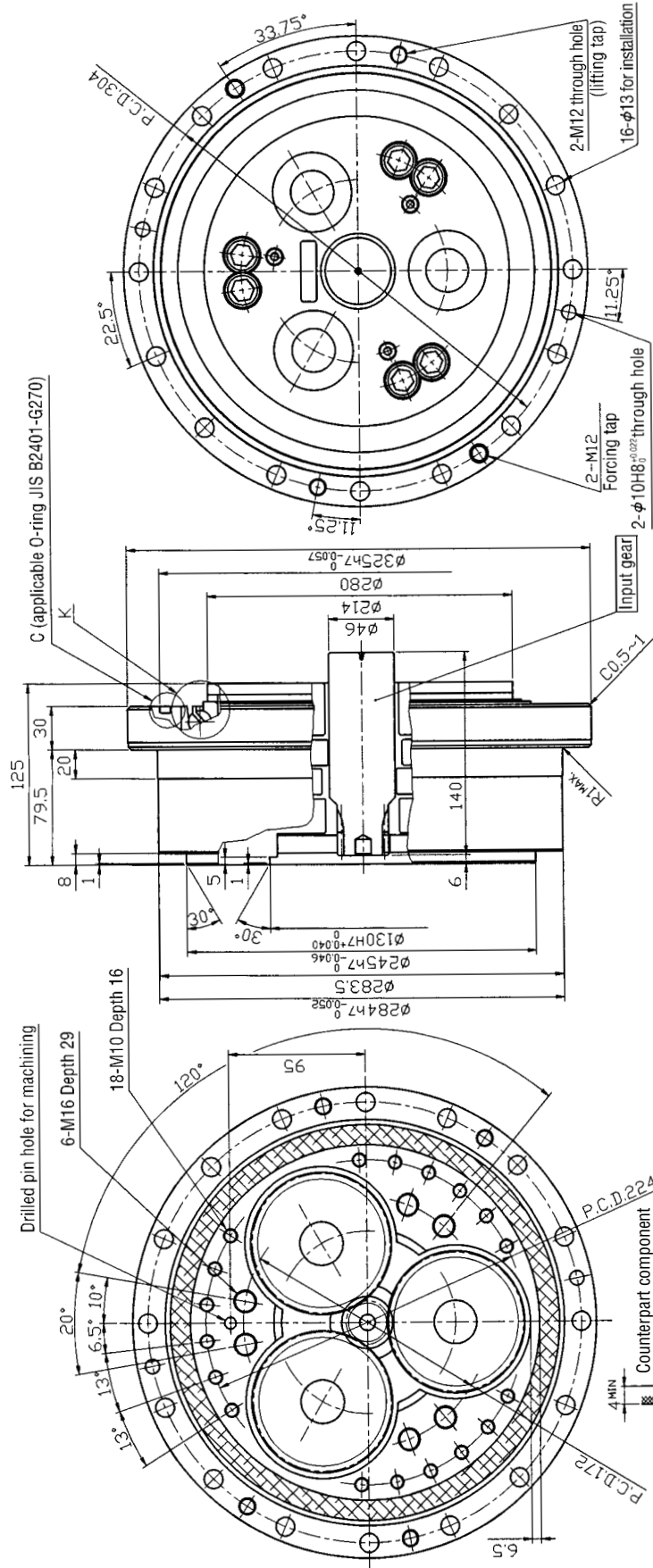

Detail of input gear (standard type A)

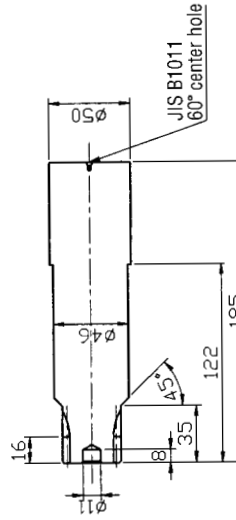

Detail of input gear (standard type B)

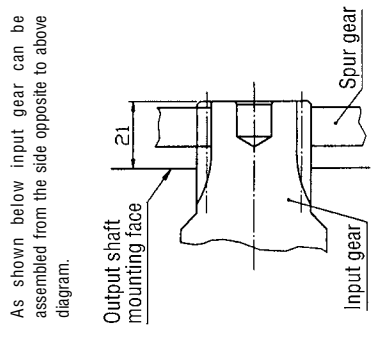

As shown below input gear can be assembled from the side opposite to above diagram.

Allowable transmission torque

	Bolt	Taper pin	Total
Case side	20,099.8Nm		20,099.8Nm
Shaft side	19,521.6Nm		19,521.6Nm

- Notes 1. The input gear profile is different when reduction ratio is small ($i=1/66$). Refer to page 27 & 28.
- 2. Use commercial goods to supply items such as O-rings, mounting bolts and seal washers.
- 3. Specifications and dimensions are subject to change without notice.

8-12 RV-450E External dimensions of bolt clamping output shaft type (1 piece input gear) Type code RV-450E-□-□-^A/_B-B

Speed ratio

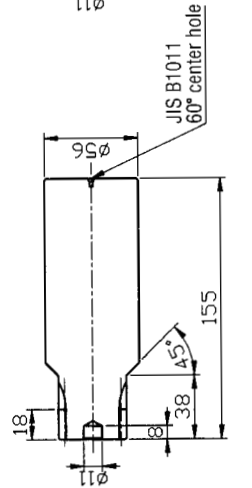
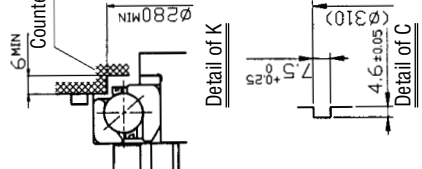
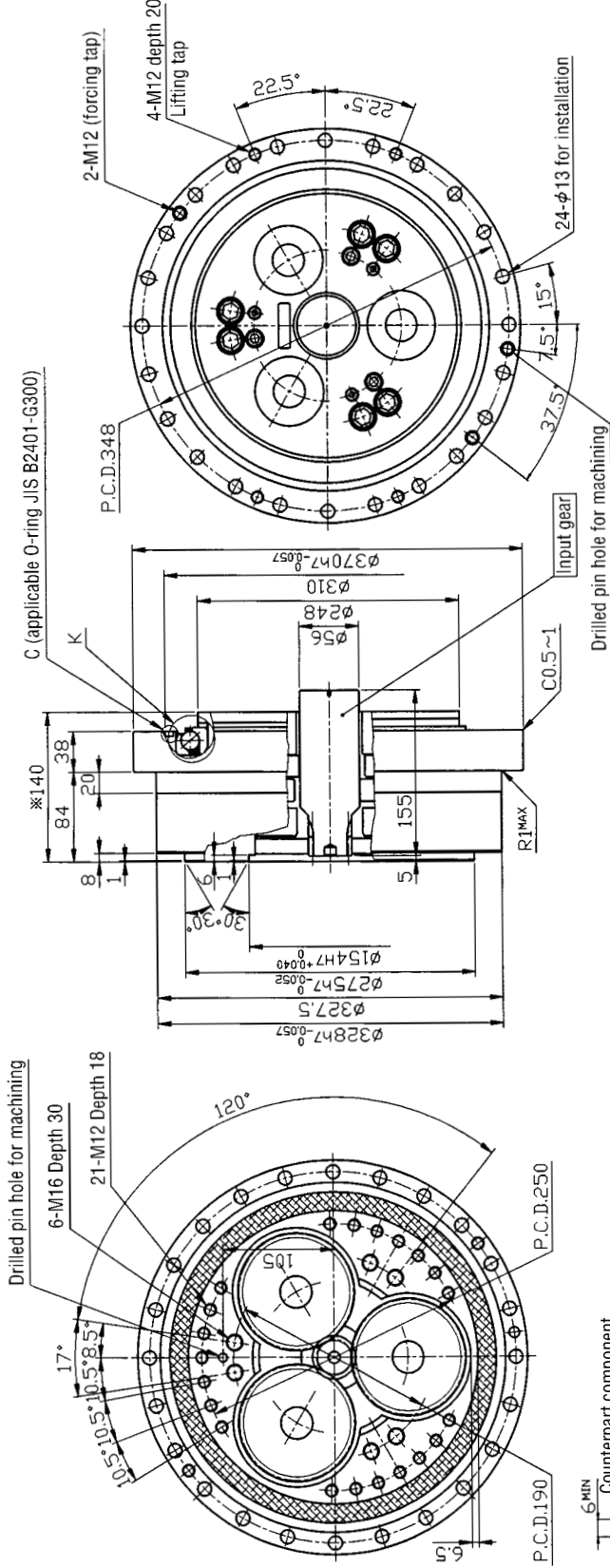

Detail of input gear (standard type A)

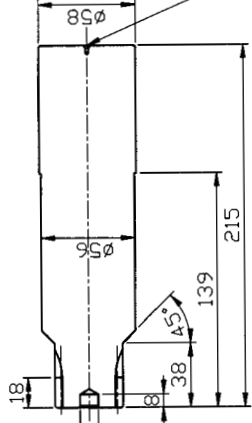

Detail of input gear (standard type B)

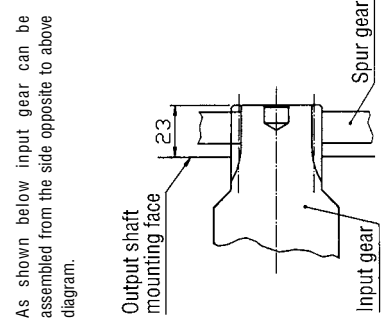

Allowable transmission torque

	Bolt	Taper pin	Total
Case side	34,515.6Nm		34,515.6Nm
Shaft side	30,536.8Nm		30,536.8Nm

- Notes 1. Values marked by asterisk (*) differ from RV-380AII.
- 2. The input gear profile is different when reduction ratio is small ($i=1/66$). Refer to page 27 & 28.
- 3. Use commercial goods to supply items such as O-rings, mounting bolts and seal washers.
- 4. Specifications and dimensions are subject to change without notice.

8-13 RV-20E External dimensions of pin and bolt clamping output shaft type (2 piece input gear) Type code RV-20E-57-A-P

Speed ratio

A/B

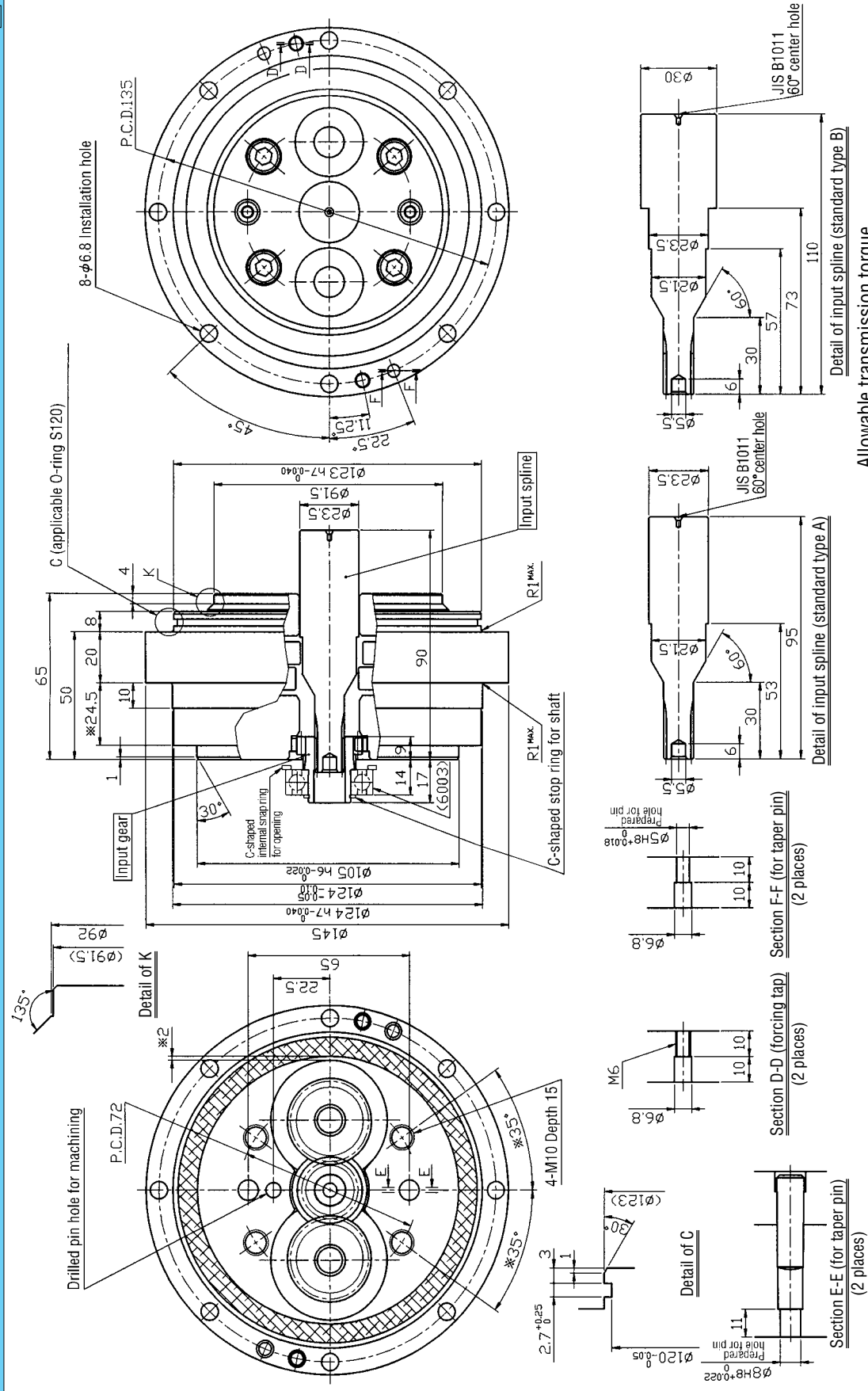

Allowable transmission torque

	Bolt	Taper pin	Total
Case side	1,068.2Nm	519.4Nm	1,587.6Nm
Shaft side	823.2Nm	637Nm	1,460.2Nm

- Notes 1. The asterisk marked values differ from RV-15AII.
 2. Uses bolts and tapered pins to connect case and shaft.
 3. Use commercial goods to supply items such as O-rings, mounting bolts, seal washers, deep groove ball bearings, C-shaped snap rings and taper pins.
 4. Specifications and dimensions are subject to change without notice.

Speed ratio $\frac{A}{B}$ Type code RV-20E-□-□-P

8-14 RV-20E External dimensions of pin and bolt clamping output shaft type (1 piece input gear)

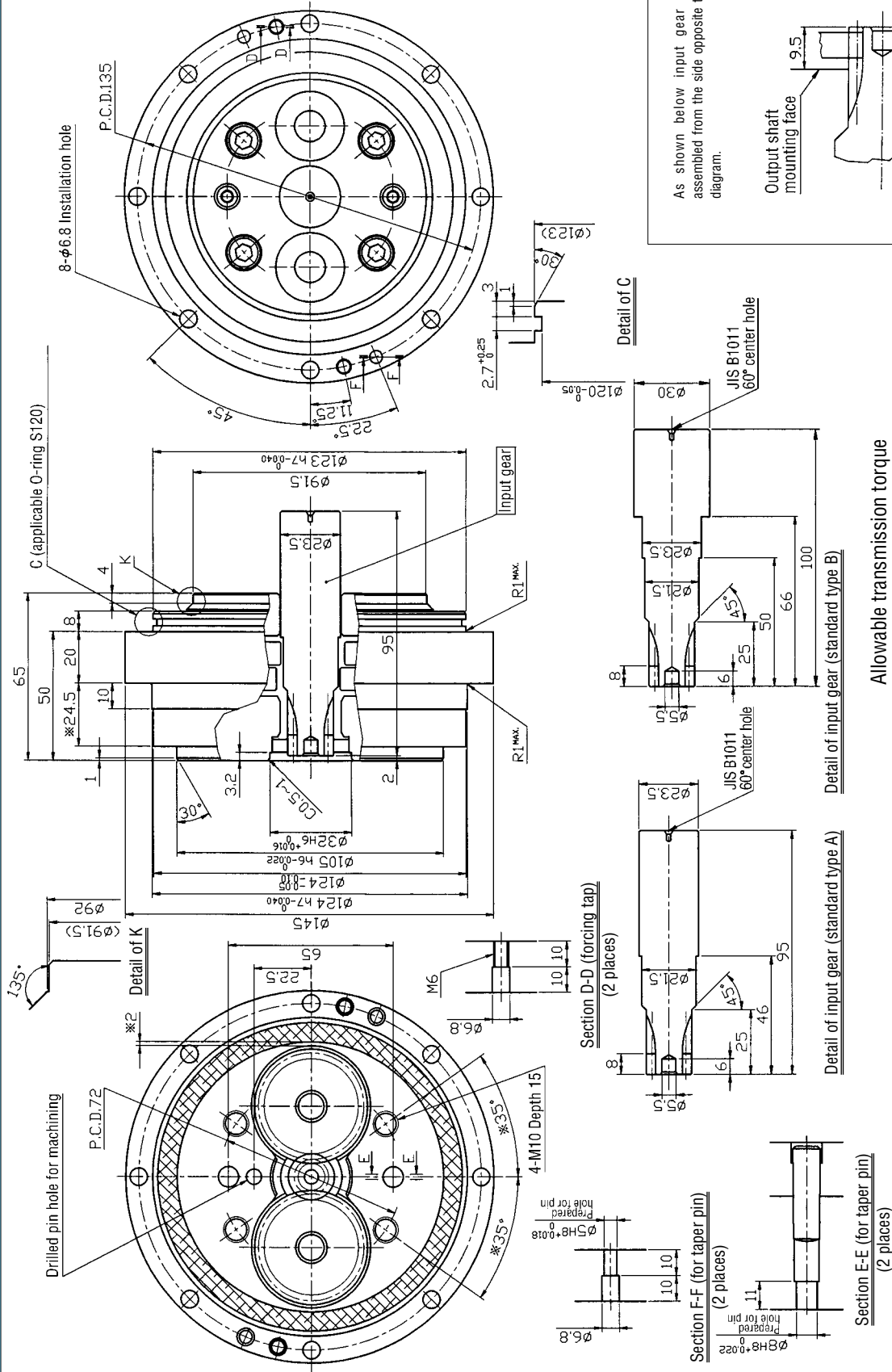

Allowable transmission torque

	Bolt	Taper pin	Total
Case side	1,068.2Nm	519.4Nm	1,587.6Nm
Shaft side	823.2Nm	637Nm	1,460.2Nm

- Notes 1. Values marked by asterisk (*) differ from RV-15AIL.
 2. Uses bolts and tapered pins to connect case and shaft.
 3. Use commercial goods to supply items such as O-rings, mounting bolts, seal washers and taper pins.
 4. Specifications and dimensions are subject to change without notice.

8-15 RV-40E External dimensions of pin and bolt clamping output shaft type (2 piece input gear) Type code RV-40E-57-A-B -P

Speed ratio

A-B

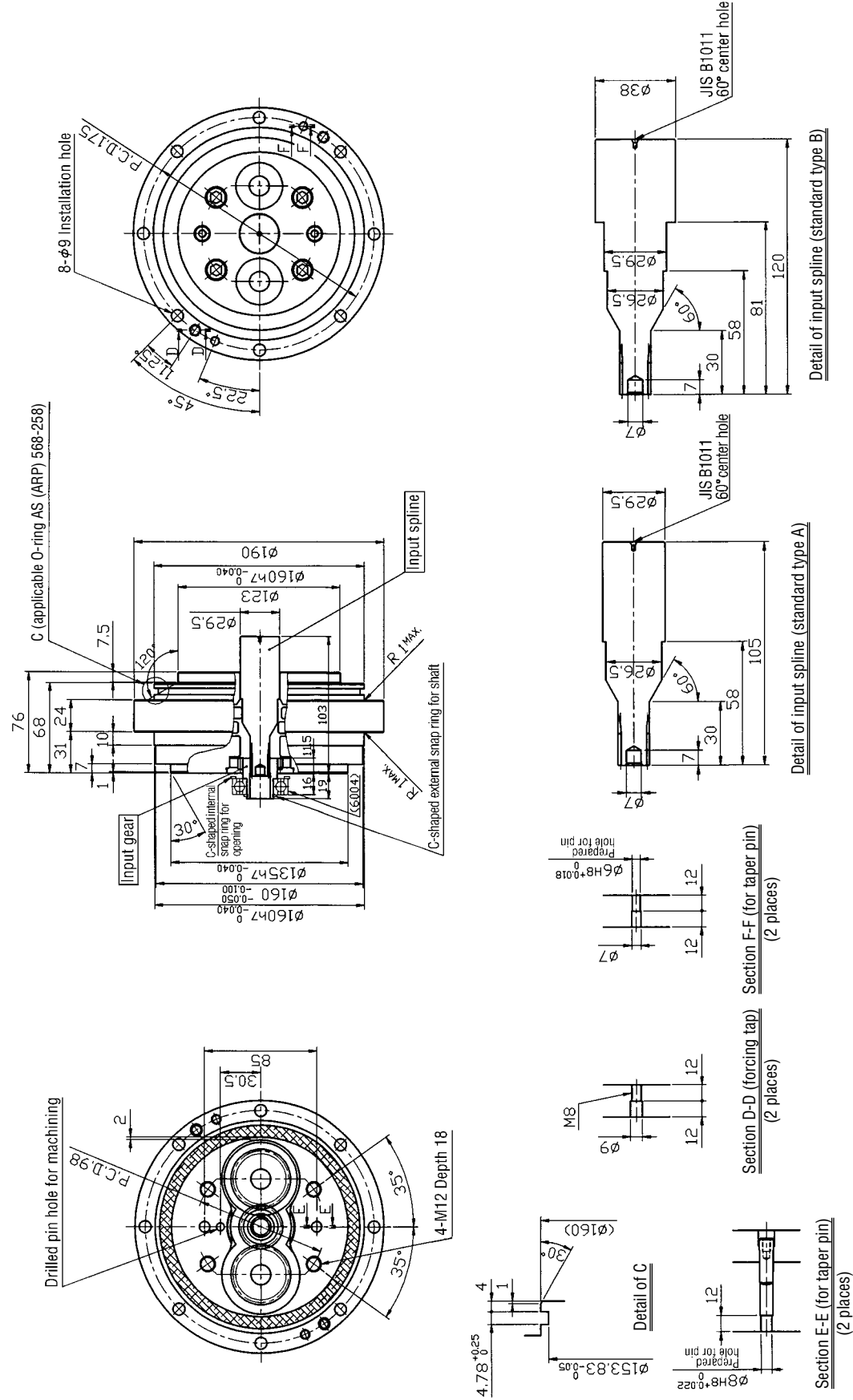

Allowable transmission torque

	Bolt	Taper pin	Total
Case side	2,518.6Nm	970.2Nm	3,488.8Nm
Shaft side	1,617Nm	833Nm	2,450Nm

- Notes 1. Uses bolts and tapered pins to connect case and shaft.
 2. Use commercial goods to supply items such as O-rings, mounting bolts, seal washers, deep groove ball bearings, C-shaped snap rings and taper pins.
 3. Specifications and dimensions are subject to change without notice.

8-16 RV-40E External dimensions of pin and bolt clamping output shaft type (1 piece input gear) Type code RV-40E- - - -P

Speed ratio

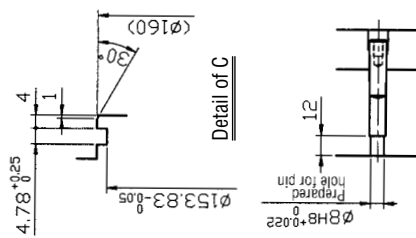
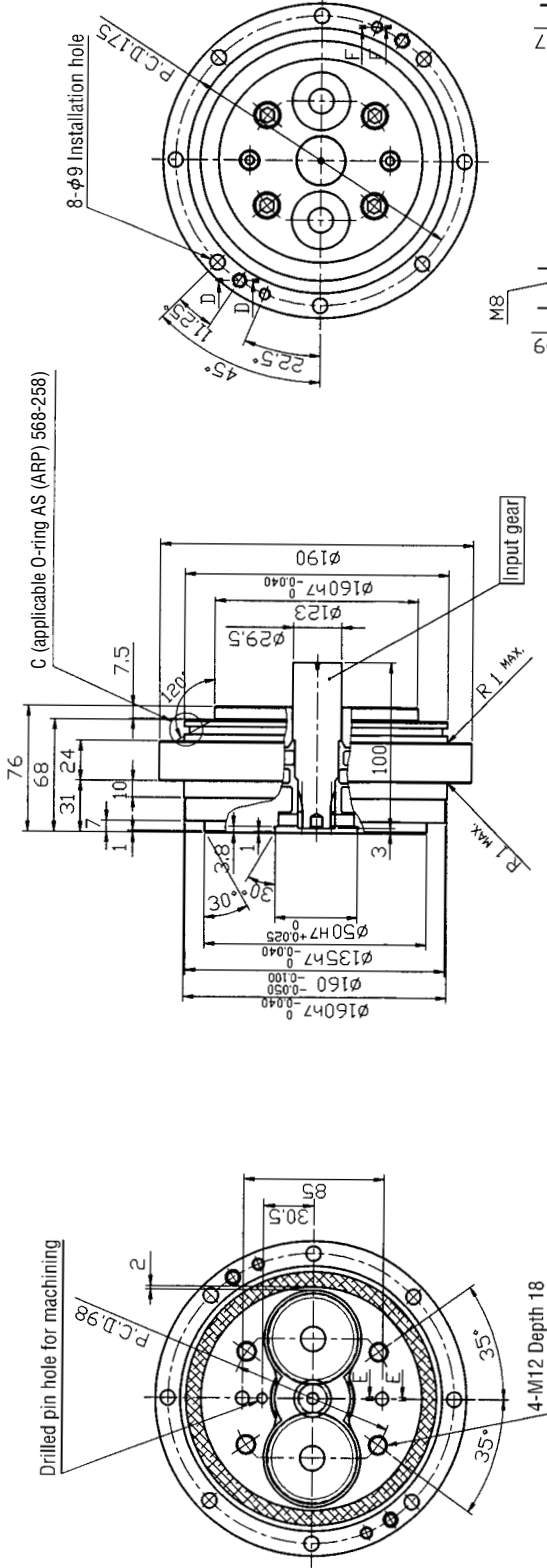

Section E-E (for taper pin)
(2 places)

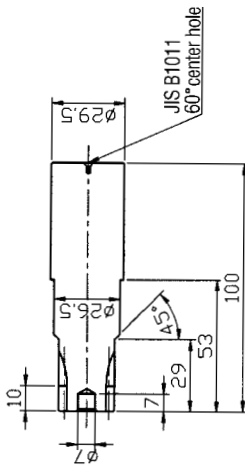

Detail of input gear (standard type A)

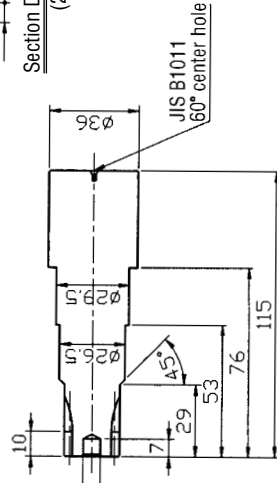

Detail of input gear (standard type B)

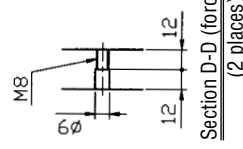

Section D-D (forcing tap)
(2 places)

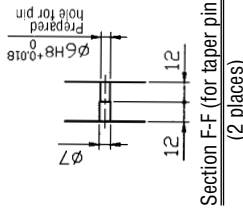

Section F-F (for taper pin)
(2 places)

As shown below input gear can be assembled from the side opposite to above diagram.

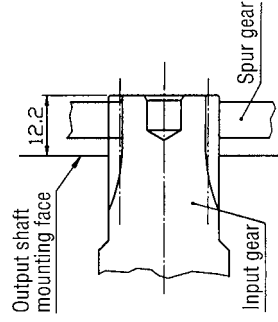

Allowable transmission torque

	Bolt	Taper pin	Total
Case side	2,518.6Nm	970.2Nm	3,488.8Nm
Shaft side	1,617Nm	833Nm	2,450Nm

- Notes 1. Uses bolts and tapered pins to connect case and shaft.
 2. Use commercial goods to supply items such as O-rings, mounting bolts, seal washers and taper pins.
 3. Specifications and dimensions are subject to change without notice.

8-17 RV-80E External dimensions of pin and bolt clamping output shaft type (2 piece input gear) Type code RV-80E-57-A-P

Speed ratio $\frac{A}{B}$

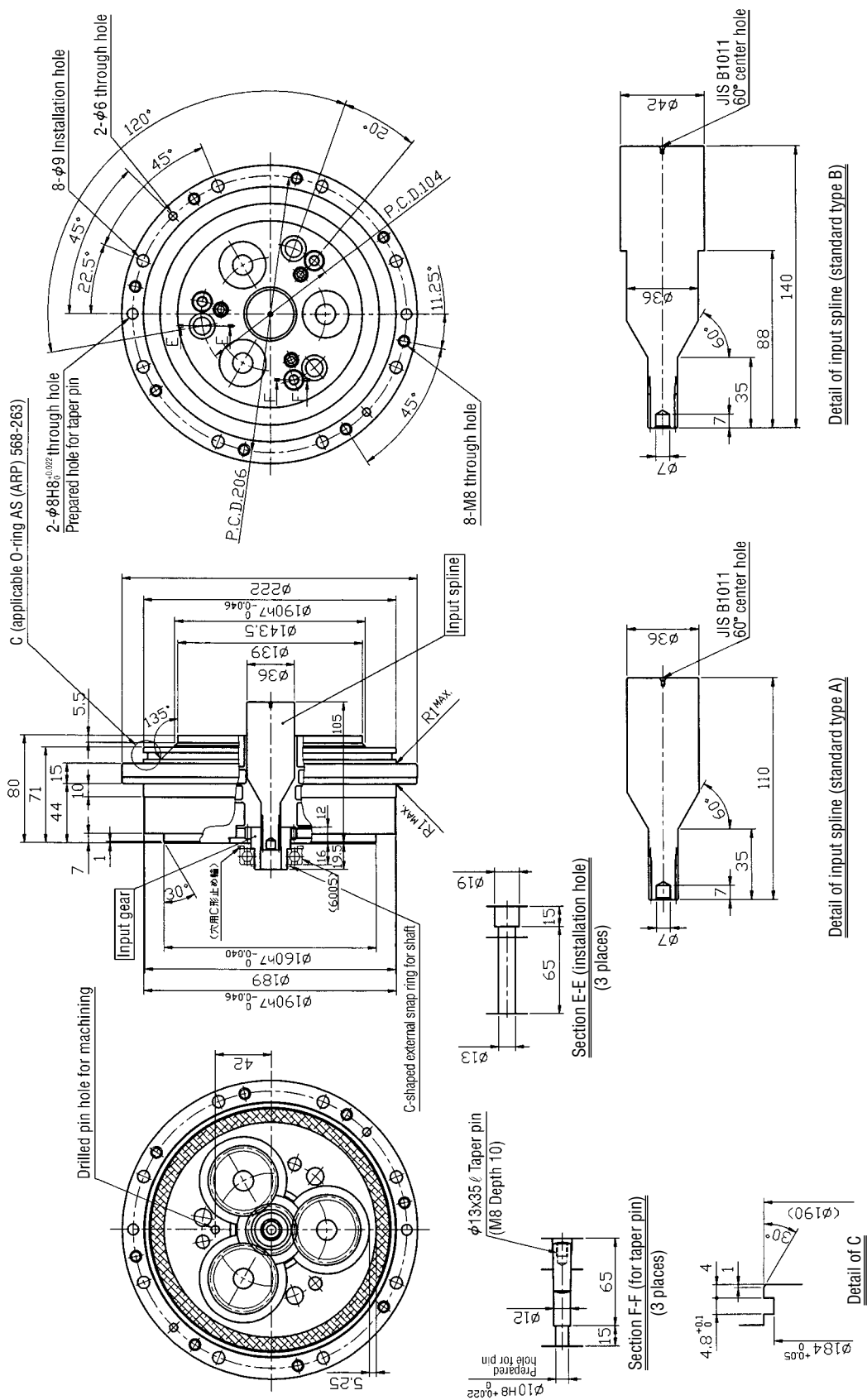

Detail of input spline (standard type B)

Detail of input spline (standard type A)

Allowable transmission torque

	Bolt	Taper pin	Total
Case side	2,959.6Nm	2,028.6Nm	4,988.2Nm
Shaft side	1,019.2Nm	2,401Nm	3,420.2Nm

- Notes 1. Install taper pin (section F-F) on output shaft referring to the RV-80E assembly example (page 24).
 2. Uses bolts and tapered pins to connect case and shaft.
 3. Use commercial goods to supply items such as O-rings, mounting bolts, seal washers, deep groove ball bearings, C-shaped snap rings and taper pins.
 4. Specifications and dimensions are subject to change without notice.

8-18 RV-80E External dimensions of pin and bolt clamping output shaft type (1 piece input gear) Type code RV-80E-□-□-**A**-**B**-P

Speed ratio

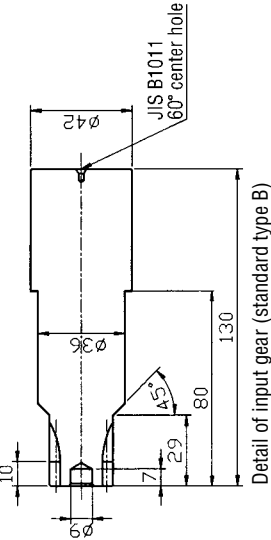
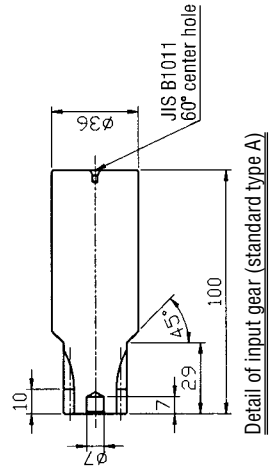
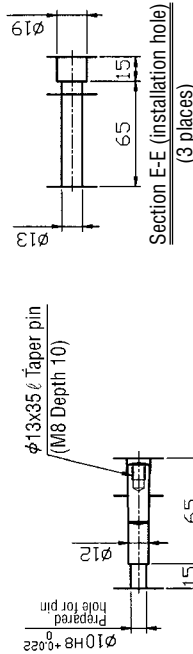
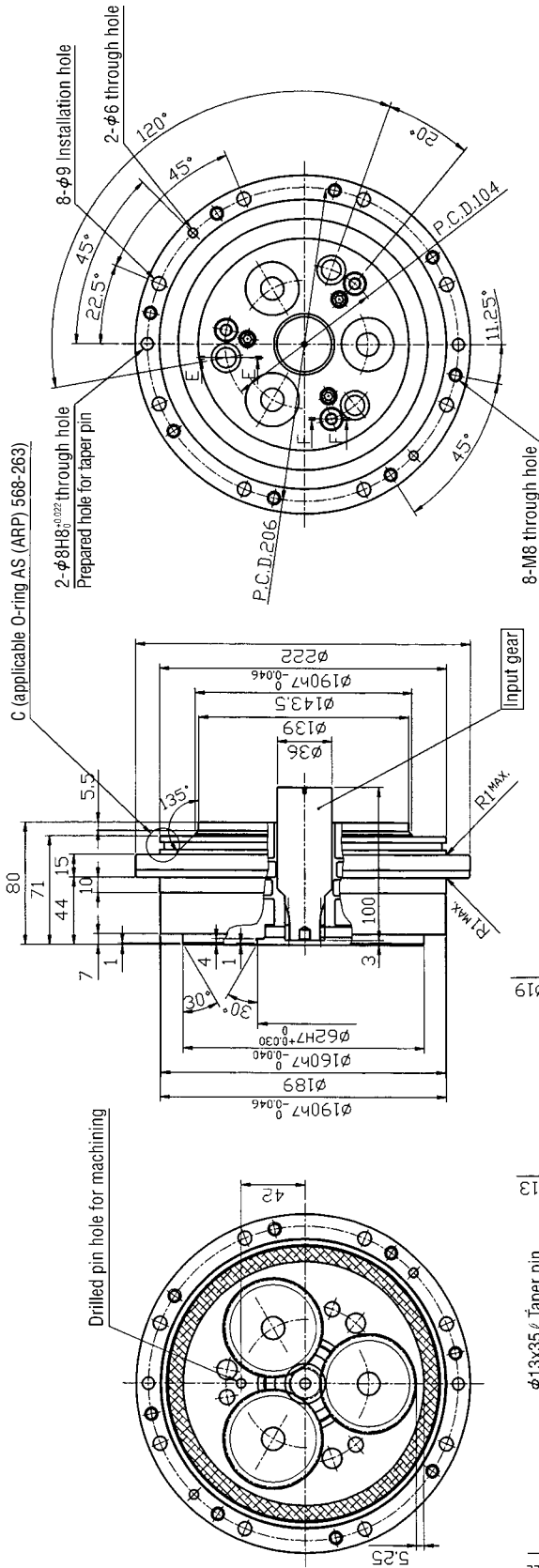

As shown below input gear can be assembled from the side opposite to above diagram.

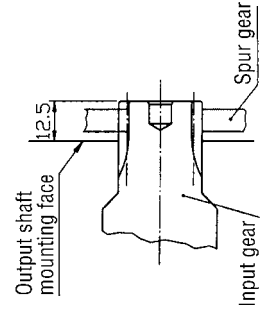

Allowable transmission torque

	Bolt	Taper pin	Total
Case side	2,959.6Nm	2,028.6Nm	4,988.2Nm
Shaft side	1,019.2Nm	2,401Nm	3,420.2Nm

- Notes 1. Install taper pin (section F-F) on output shaft referring to the RV-80E assembly example (page 24).
2. Uses bolts and tapered pins to connect case and shaft.
3. Use commercial goods to supply items such as O-rings, mounting bolts, seal washers and taper pins.
4. Specifications and dimensions are subject to change without notice.
5. The 1/153 is not to be used. When the use of 1/153 is required, use the bolt joint output shaft type.

8-19 RV-160E External dimensions of pin and bolt clamping output shaft type (1 piece input gear) Type code RV-160E- \square - \square - \square -A-B-P

Speed ratio

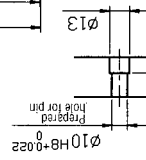
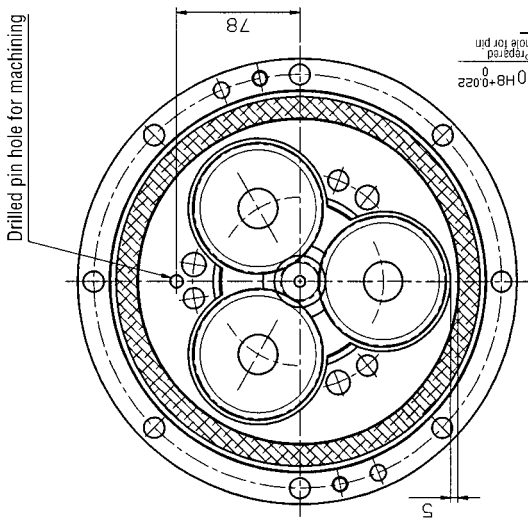
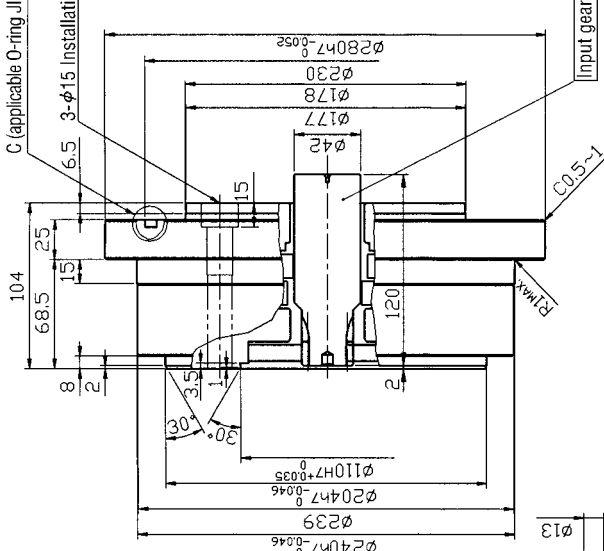
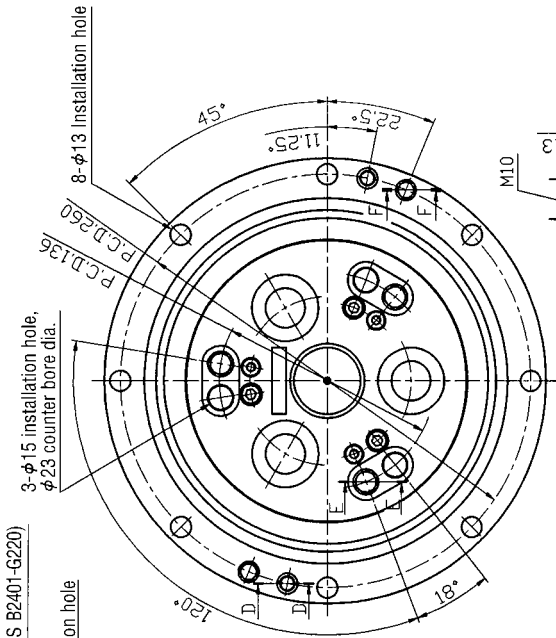

Section F-F (for taper pin)
(2 places)

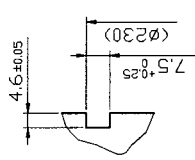

Detail of C

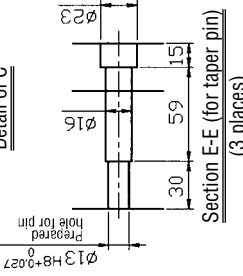

Section E-E (for taper pin)
(3 places)

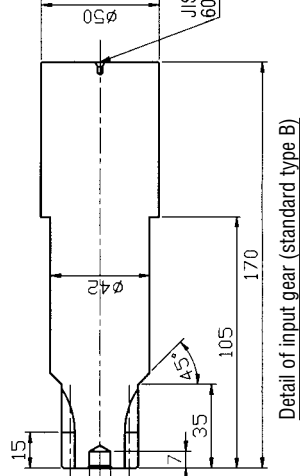

Detail of input gear (standard type B)

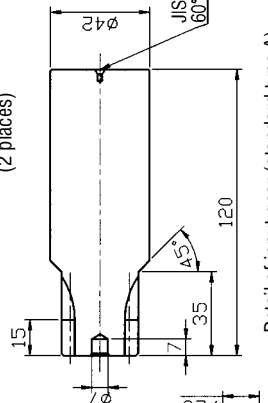

Detail of input gear (standard type A)

Section D-D (forcing tap)
(2 places)

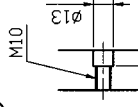

As shown below input gear can be assembled from the side opposite to above diagram.

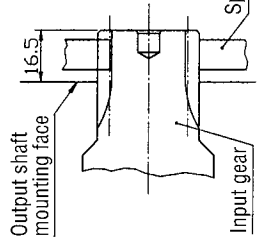

Allowable transmission torque

	Bolt	Taper pin	Total
Case side	8,594.6Nm	3,988.4Nm	12,593Nm
Shaft side	2,322.6Nm	5,311.6Nm	7,634.2Nm

1. The input gear profile is different when reduction gear is small (i=1/66). Refer to page 27 & 28.
2. Uses bolts and tapered pins to connect case and shaft.
3. Use commercial goods to supply items such as O-rings, mounting bolts, seal washers and taper pins.
4. Specifications and dimensions are subject to change without notice.

8-20 RV-320E External dimensions of pin and bolt clamping output shaft type (1 piece input gear) Type code RV-320E-□-□-A-B-P

Speed ratio

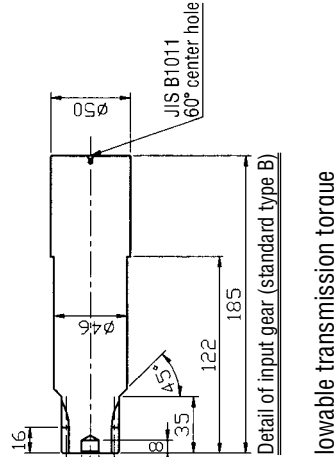
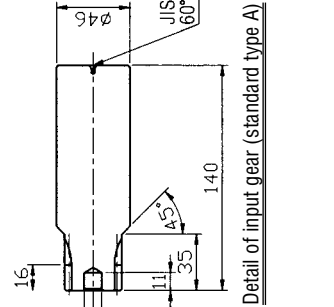
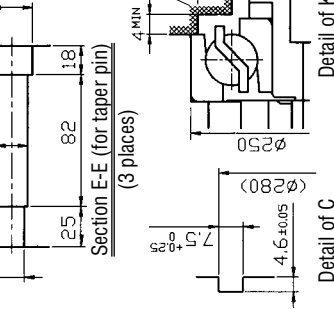
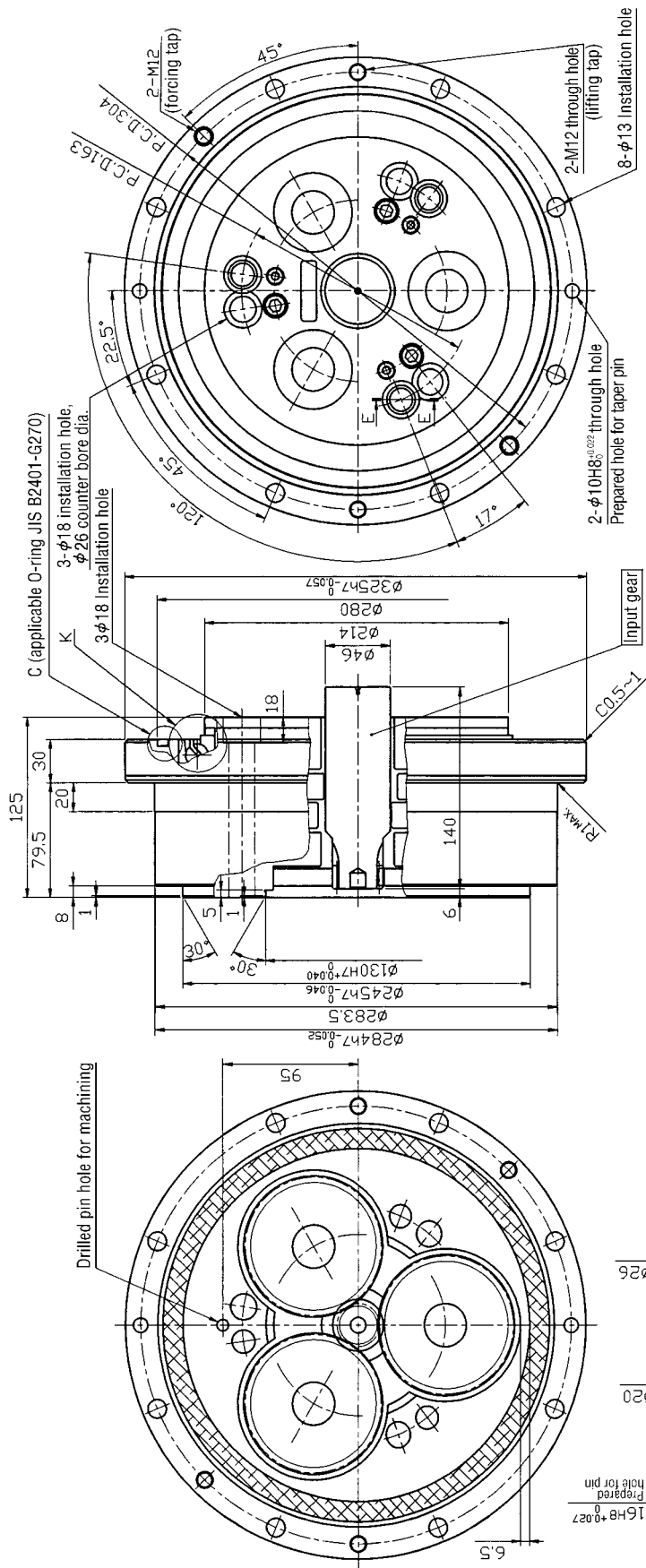

- Notes 1. The input gear profile is different when reduction gear is small (=1/66). Refer to page 27 & 28.
 2. Uses bolts and tapered pins to connect case and shaft.
 3. Use commercial goods to supply items such as O-rings, mounting bolts, seal washers and taper pins.
 4. Specifications and dimensions are subject to change without notice.

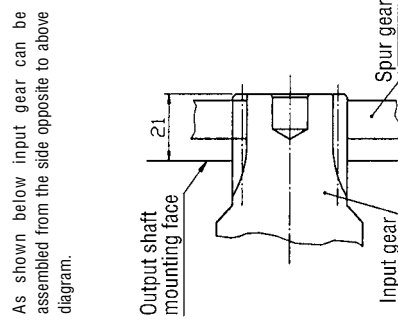

Allowable transmission torque

	Bolt	Taper pin	Total
Case side	10,045Nm	4,684.4Nm	14,729Nm
Shaft side	3,792.6Nm	9,633.4Nm	13,426Nm

8-21 RV-450E External dimensions of pin and bolt clamping output shaft type (1 piece input gear) Type code RV-450E-□-A-P

Speed ratio

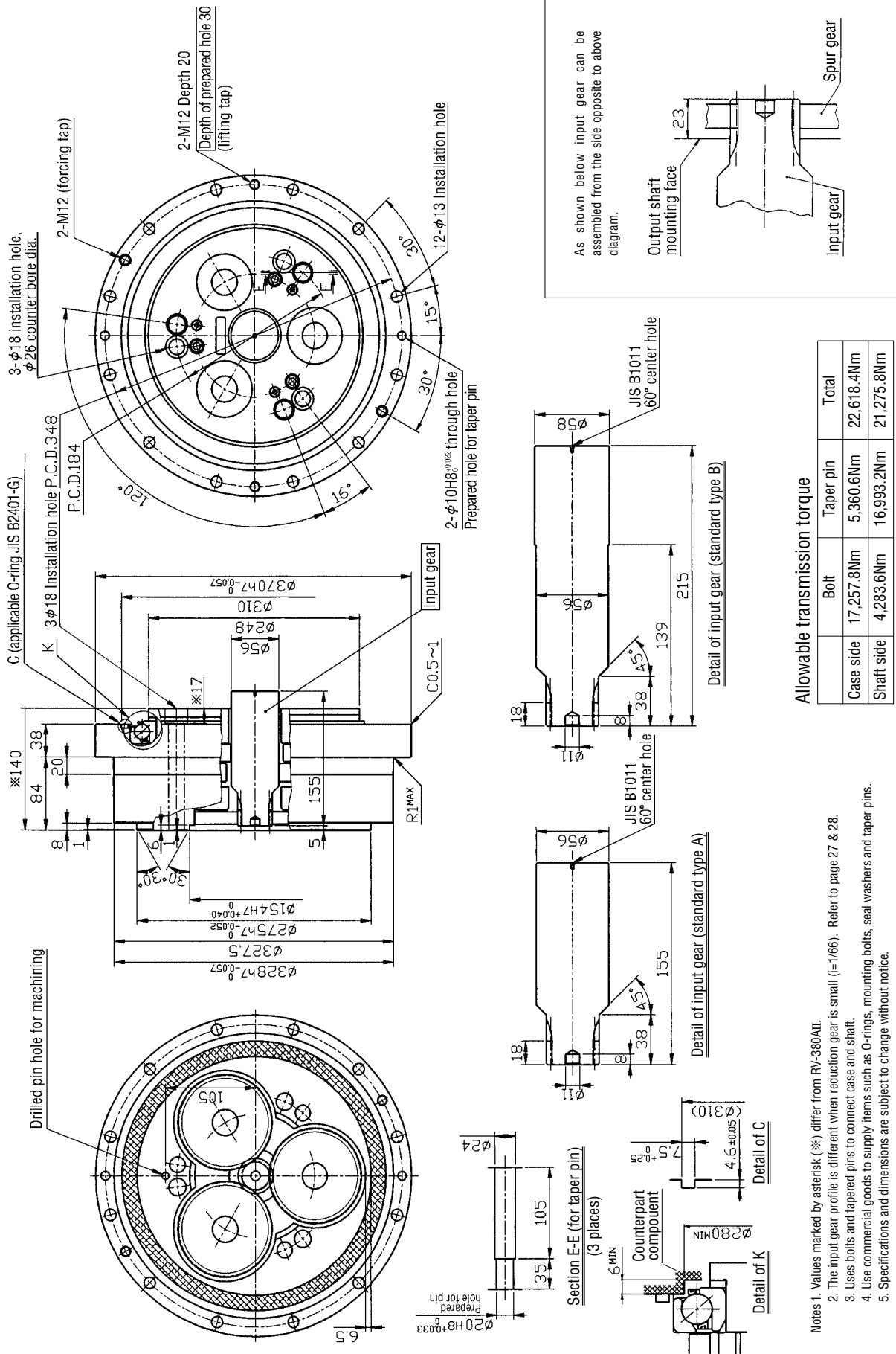

- Values marked by asterisk (*) differ from RV-380AII.
- The input gear profile is different when reduction gear is small (=1/66). Refer to page 27 & 28.
- Uses bolts and tapered pins to connect case and shaft.
- Use commercial goods to supply items such as O-rings, mounting bolts, seal washers and taper pins.
- Specifications and dimensions are subject to change without notice.

RV-C

series

1 FEATURES AND BENEFITS

Fig.1

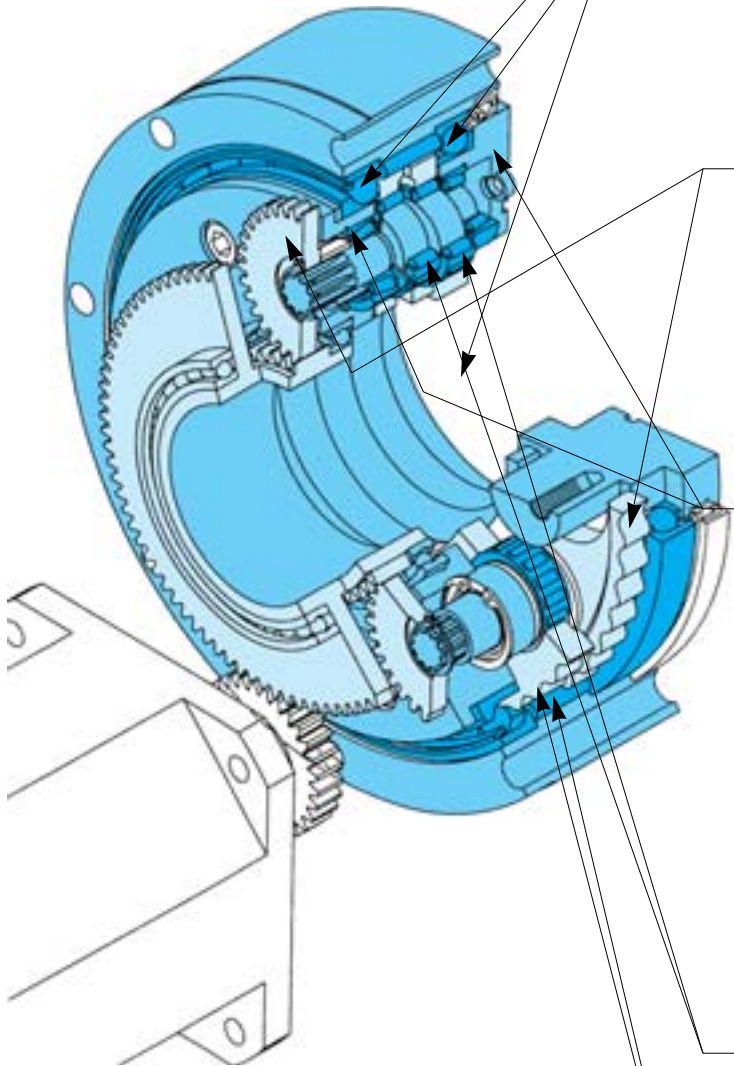

Hollow shaft structure

- Cables and other lines can pass through the reduction gear
- Allows space saving design

INTEGRATED ANGULAR BALL BEARINGS

Benefits:

- Increases reliability
- Reduces overall cost

Attributed to:

- Built-in angular ball bearing construction improves ability to support external loads, increases moment rigidity and maximum allowable moment.
- Reduces the number of components required.
- Simplifies installation and maintenance.

2 STAGE REDUCTION

Benefits:

- Reduces vibration
- Reduces inertia (GD^2)

Attributed to:

- Low speed rotation of the RV gear reduces vibration.
- Reduced size of the motor coupling part (input gear) lowers inertia.

ALL MAIN ELEMENTS ARE SUPPORTED FROM BOTH SIDES

Benefits:

- Higher torsional stiffness
- Less vibration
- High shock load capability (5 times rated torque)

Detail:

- Crankshafts are supported on both sides of the reduction gear as shown below.

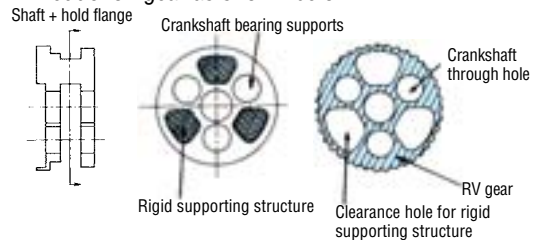

ROLLING CONTACT ELEMENTS

Benefits:

- Excellent starting efficiency
- Low wear and longer life
- Low backlash (Less than 1 arc. min.)

Attributed to:

- Use of roller bearings throughout.

PIN & GEAR STRUCTURE

Benefits:

- Very low backlash (Less than 1 arc. min.)
- Higher shock load capability (5 times rated torque)

Attributed to:

- Synchromeshing of many precision ground gear teeth and pins.

2 CONSTRUCTION and OPERATION PRINCIPLE

Construction

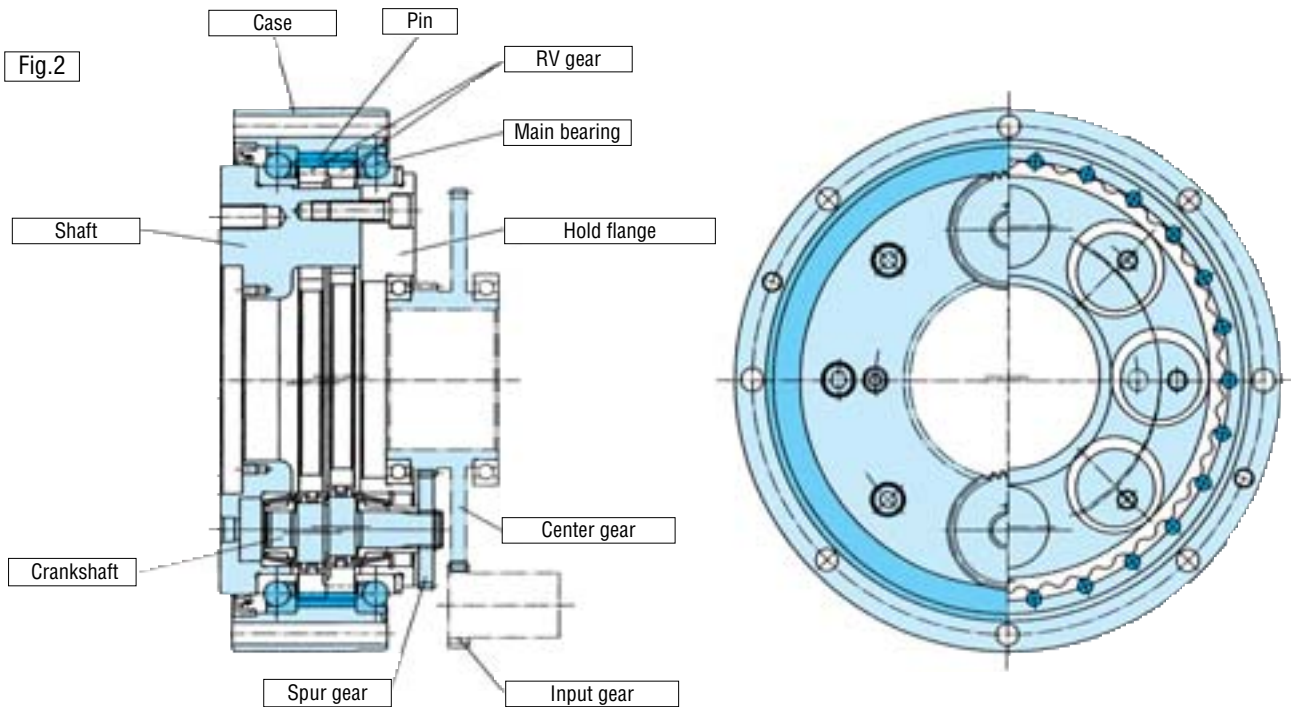

Principle of speed reduction

The RV-C is a 2-stage reduction gear.

1st stage ...Spur gear reduction

- An input gear engages with and rotates a center gear which then engages and rotates spur gears that are coupled to crankshafts. Several overall gear ratios can be provided by selecting various first stage ratios.

2nd stage ...Epicyclic gear reduction

- Crankshafts driven by the spur gears cause an eccentric motion of two epicyclic gears called RV gears that are offset 180 degrees from one another to provide a balanced load.
- The eccentric motion of the RV gears causes engagement of the cycloidal shaped gear teeth with cylindrically shaped pins located around the inside edge of the case.
- In the course of one revolution of the crankshafts the teeth of the RV gear move the distance of one pin in the opposite direction of the rotating cranks. The motion of the RV gear is such that the teeth remain in close contact with the pins and many teeth share the load simultaneously.
- The output can be either the shaft or the case. If the case is fixed, the shaft is the output. If the shaft is fixed, the case is the output.

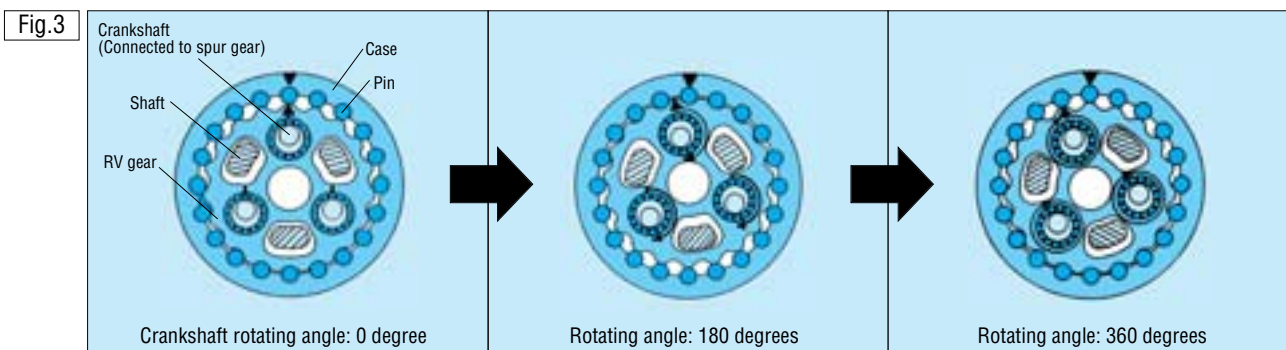

3 ROTARY DIRECTION and SPEED RATIO

The rotary direction and speed ratio of the RV-C reduction gear are shown below.

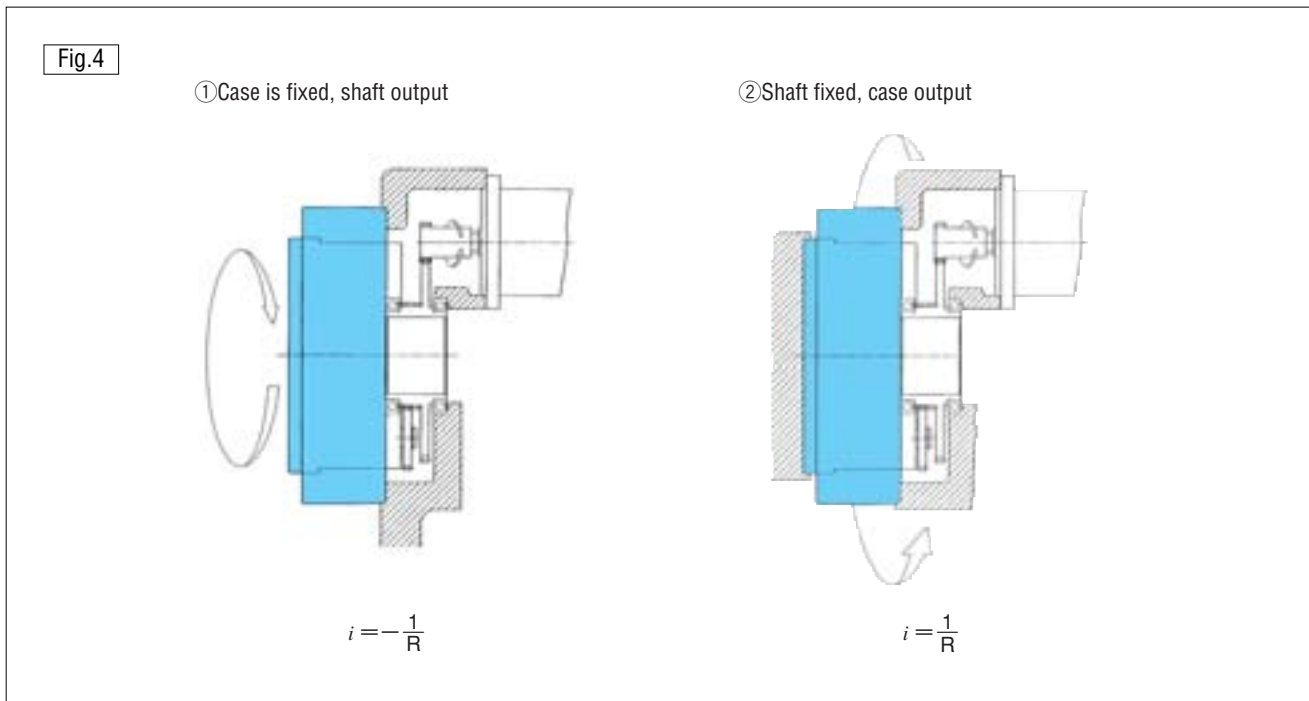

Mechanism block drawing

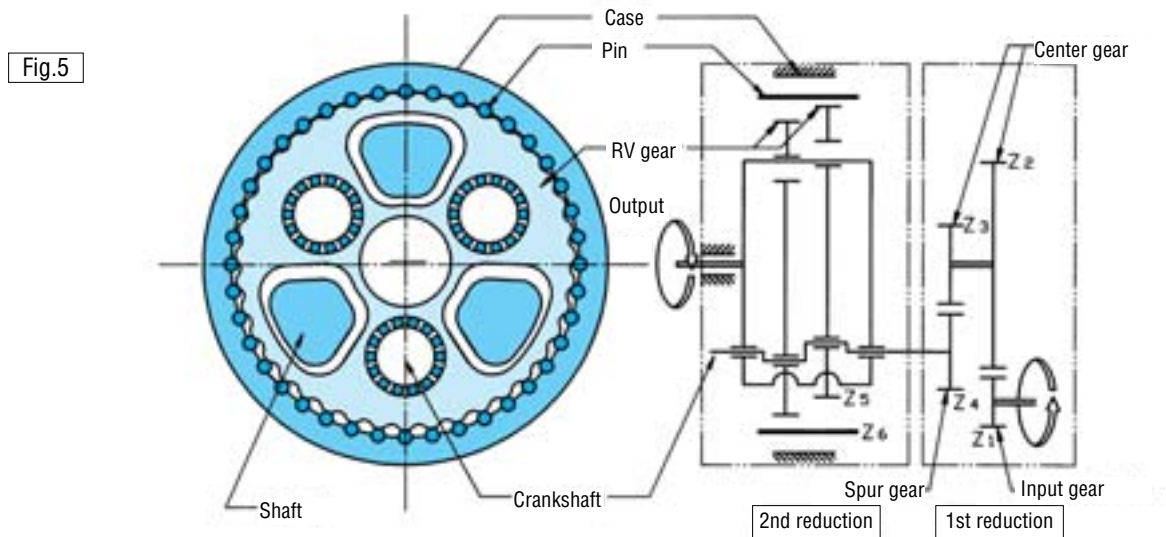

Speed Ratio

The overall ratio can be determined from the following equation:

With the shaft as output; $R = R_1 \times \frac{Z_2}{Z_1}$

$$i = \frac{-1}{R}$$

$$(R_1 = 1 + \frac{Z_4}{Z_3} \cdot Z_6)$$

- R : Overall speed ratio
- R₁ : Speed ratio of a discrete reduction gear
- Z₁ : Number of teeth on input gear
- Z₂ : Number of teeth on large center gear
- Z₃ : Number of teeth on small center gear
- Z₄ : Number of teeth on spur gear
- Z₅ : Number of teeth on RV gear
- Z₆ : Number of pins
- i : Reduction ratio

4 RATING TABLE

Table 1

Output speed (r/min)		5		10		15		20		25		30		40		50	
Model	Speed ratio of a discrete reduction gear (R _i)	Output torque	Input capacity	Output torque	Input capacity	Output torque	Input capacity	Output torque	Input capacity	Output torque	Input capacity	Output torque	Input capacity	Output torque	Input capacity	Output torque	Input capacity
		In-lb (Nm)	kW	In-lb (Nm)	kW	In-lb (Nm)	kW	In-lb (Nm)	kW	In-lb (Nm)	kW	In-lb (Nm)	kW	In-lb (Nm)	kW	In-lb (Nm)	kW
RV-10C	27	1,204 (136)	0.09	983 (111)	0.16	868 (98)	0.21	797 (90)	0.25	744 (84)	0.29	709 (80)	0.34	647 (73)	0.41	602 (68)	0.47
RV-27C	36.57 (1,390/38)	3,259 (368)	0.26	2,648 (299)	0.42	2,347 (265)	0.55	2,152 (243)	0.68	2,010 (227)	0.79	1,904 (215)	0.90	1,745 (197)	1.10	1,630 (184)	1.29
RV-50C	32.54 (1,985/61)	6,031 (681)	0.48	4,907 (554)	0.77	4,340 (490)	1.03	3,985 (450)	1.26	3,720 (420)	1.47	3,525 (398)	1.67	3,242 (366)	2.04	3,020 (341)	2.38
RV-100C	36.75	12,063 (1362)	0.95	9,804 (1107)	1.55	8,679 (980)	2.05	7,962 (899)	2.51	7,448 (841)	2.94	7,050 (796)	3.33	6,465 (730)	4.08		
RV-200C	34.86 (1,499/43)	24,125 (2,724)	1.90	19,617 (2,215)	3.09	17,368 (1,961)	4.11	15,968 (1,803)	5.04	14,932 (1,686)	5.88	14,144 (1,597)	6.69				
RV-320C	35.61 (2,778/78)	38,624 (4,361)	3.04	31,335 (3,538)	4.94	27,774 (3,136)	6.57	25,516 (2,881)	8.05	23,824 (2,690)	9.41						
RV-500C	37.34	60,322 (6,811)	4.75	49,039 (5,537)	7.73	43,397 (4,900)	10.26	39,837 (4,498)	12.56								

- Notes: 1. The overall speed ratio is calculated with the formula in page 56.
 2. Set maximum input shaft speed to a value equal to or lower than the value of maximum allowable output speed multiplied by the overall speed ratio for each type.
 3. The input capacity (KW) in the above table is determined by the efficiency of these reduction gears.
 4. The output torque (In-lb) is so determined that the service life may be maintained constant for any output revolutions. ($N \cdot T^{\frac{10}{3}} = \text{Constant}$)
 5. The rated torque is a torque at an output speed of 15 r/min, which is used as a basis for service life calculations. (Refer to the rated service life, page 61.)

60		Moment rigidity Typical Value In-lb/ arc.min. (Nm/arc.min.)	Allowable moment In-lb (Nm)	Momentary max. allowable moment (Shockload) In-lb (Nm)	Allowable max. output speed (Continuous) r/min	Allowable acceleration/ deceleration torque In-lb (Nm)	Momentary max. allowable torque (E-stop) In-lb (Nm)	Lost motion MAX. arc.min.	Torsional rigidity (Stiffness) Typical Value In-lb/ arc.min. (Nm/arc.min.)	$I(=\frac{GD^2}{4})$ (Inertia of reduction gear unit) kg-m ²	$I(=\frac{GD^2}{4})$ (Inertia of center gear) kg-m ²	Weight lb (kg)
Output torque In-lb (Nm)	Input capacity kW											
576 (65)	0.54	3,726 (421)	6,076 (686)	12,151 (1,372)	80	2,170 (245)	4,340 (490)	1	416 (47)	1.34×10^{-5}	0.678×10^{-3}	10.1 (4.6)
1,541 (174)	1.46	9,452 (1,068)	8,679 (980)	17,359 (1,960)	60	5,863 (662)	11,717 (1,323)	1	1,302 (147)	0.628×10^{-4}	0.563×10^{-3}	18.7 (8.5)
		17,346 (1,960)	15,623 (1,764)	31,246 (3,528)	50	10,849 (1,225)	Bolt joint 21,699 (2,450) Through-bolt joint 17,359 (1,960)	1	2,258 (255)	1.82×10^{-4}	0.363×10^{-2}	33.1 (15)
		24,895 (2,813)	21,699 (2,450)	43,397 (4,900)	40	21,699 (2,450)	Bolt joint 43,397 (4,900) Through-bolt joint 30,378 (3,430)	1	4,517 (510)	0.47×10^{-3}	0.953×10^{-2}	43.0 (19.5)
		86,730 (9,800)	78,115 (8,820)	156,230 (17,640)	30	43,397 (4,900)	Bolt joint 86,795 (9,800) Through-bolt joint 65,096 (7,350)	1	8,679 (980)	0.995×10^{-3}	1.94×10^{-2}	125.7 (57)
		112,830 (12,740)	182,269 (20,580)	347,179 (39,200)	25	69,436 (7,840)	138,872 (15,680)	1	17,359 (1,960)	0.68×10^{-2}	0.405×10^{-1}	176.4 (80)
		216,990 (24,500)	303,781 (34,300)	694,358 (78,400)	20	108,493 (12,250)	216,987 (24,500)	1	30,378 (3,430)	0.98×10^{-2}		352.7 (160)

6. The $\frac{GD^2}{4}$ value is a value for a discrete reduction gear, and the $\frac{GD^2}{4}$ for center and input gears is not included. Therefore, refer to the following equation regarding the $\frac{GD^2}{4}$ converted to motor shaft.

$$\frac{GD^2}{4} \text{ of reduction gear unit} + \frac{GD^2}{4} \text{ of center gear} + \frac{GD^2}{4} \text{ of input gear}$$

(Number of teeth on large center gear / Number of teeth on input gear)²

7. If a higher speed than the above allowable maximum output speed is required, contact Nabtesco for further information.

8. The output revolution is for forward-reverse changeover applications and not applicable for continuous rotation in a single direction. Contact Nabtesco when using the reduction gear for continuous single-direction rotation.

5 RV-C SELECTION

5-1 Selection flow chart

Determine load characteristic

Check the load torque applied to the speed reduction gear.
An example is shown at right.

- Calculate average load torque (T_m)
- Calculate average output speed (N_m)

$$T_m = \frac{10}{3} \sqrt{\frac{t_1 \cdot N_1 \cdot T_1^{10} + t_2 \cdot N_2 \cdot T_2^{10} + \dots + t_n \cdot N_n \cdot T_n^{10}}{t_1 \cdot N_1 + t_2 \cdot N_2 + \dots + t_n \cdot N_n}}$$

$$N_m = \frac{t_1 \cdot N_1 + t_2 \cdot N_2 + \dots + t_n \cdot N_n}{t_1 + t_2 + \dots + t_n}$$

Fig.6

Duty cycle diagram

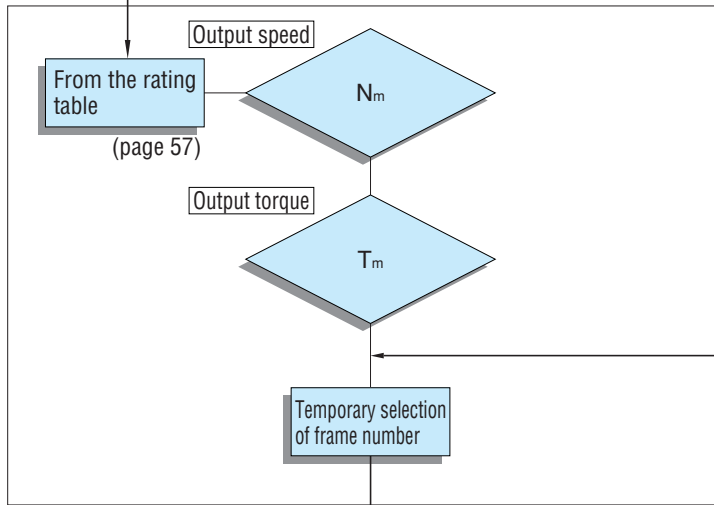
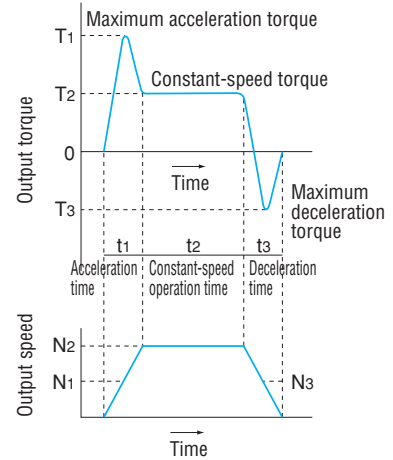

Table 2 Considerations for selection

	For starting (Max)	For constant speed	For stopping (Max)	For impact due to emergency stop
Load torque	In-lb T ₁	T ₂	T ₃	T _{em}
Speed	r/min N ₁	N ₂	N ₃	N _{em}
Time	sec t ₁	t ₂	t ₃	t _{em}

Temporary selection of frame number

Increase the frame number or reduce the load.

Service life calculation (L_h)

$$L_h = K \times \frac{N_o}{N_m} \times \left(\frac{T_o}{T_m}\right)^{10/3}$$

(Refer to page 61)

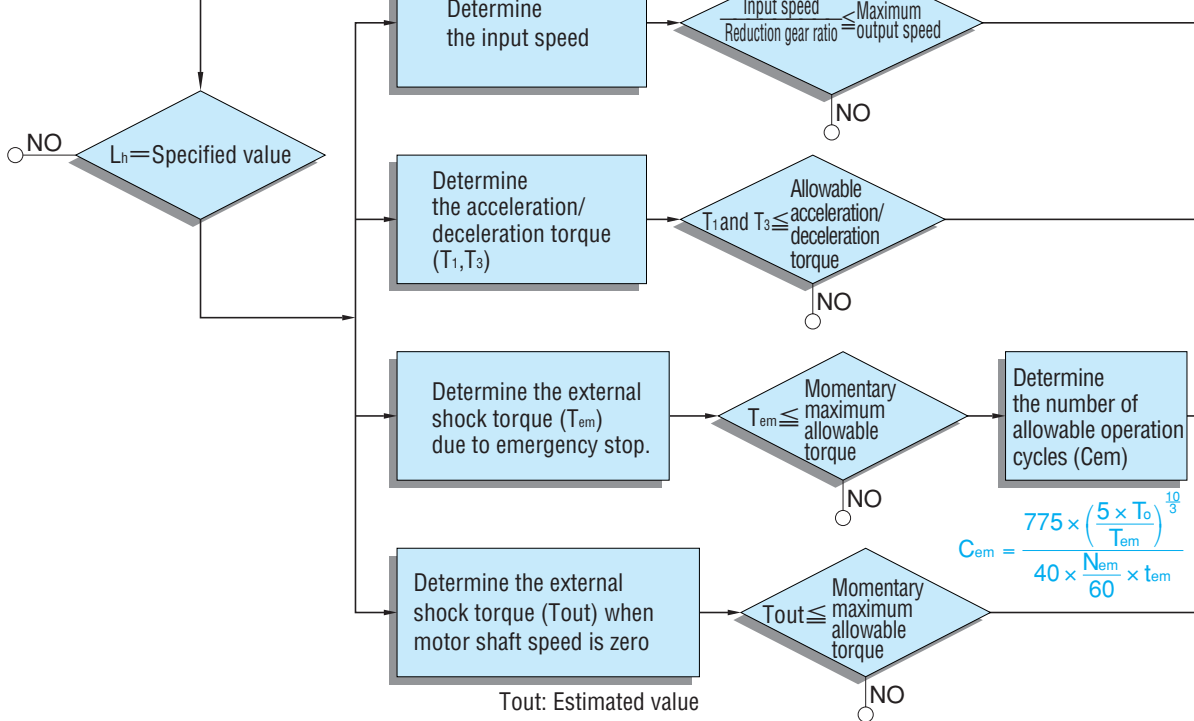

Tout: Estimated value

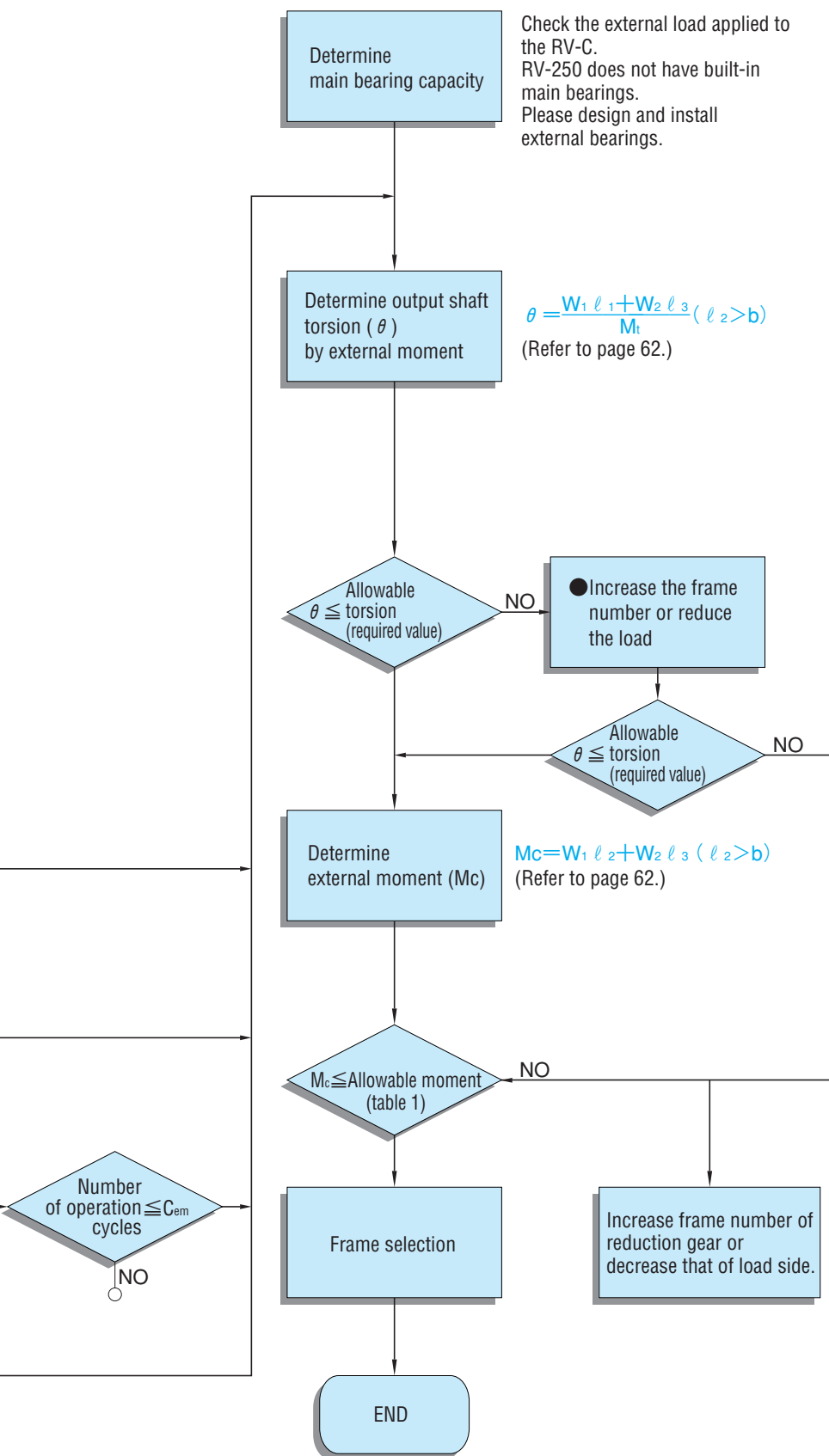

Selection example

Selection conditions

$T_1=5,310\text{In-lb}$ $T_2=1,328\text{In-lb}$
 $T_3=2,655\text{In-lb}$ $T_{em}=15,045\text{In-lb}$
 $t_1=0.2\text{sec.}$ $t_2=0.5\text{sec.}$
 $t_3=0.2\text{sec.}$ $t_{em}=0.05\text{sec.}$
 $N_1=N_3=10\text{r/min}$ $N_2=20\text{r/min}$
 $N_{em}=20\text{r/min}$

Determine load characteristic

● Determine average load torque

$$T_m = \frac{0.2 \times 10 \times 5,310^3 + 0.5 \times 20 \times 1,328^3 + 0.2 \times 10 \times 2,655^3}{0.2 \times 10 + 0.5 \times 20 + 0.2 \times 10} = 3,088\text{In-lb}$$

● Determine average output speed

$$N_m = \frac{0.2 \times 10 + 0.5 \times 20 + 0.2 \times 10}{0.2 + 0.5 + 0.2} = 15.6\text{r/min}$$

Provisional selection of RV-50C.

● Calculation to determine whether reduction gear service life meets required specification value.

$$L = 6,000 \times \frac{15}{15.6} \times \left(\frac{4,340}{3,088} \right)^{10} = 17,940\text{Hr}$$

● Determine output speed

Maximum output speed $20\text{r/min} < 50\text{r/min}$

(Maximum allowable output speed of RV-50C)

● Determine torque during starting and stopping

$T_1=5,310\text{In-lb} < 10,849\text{In-lb}$

(Allowable acc./dec. torque for RV-50C)

$T_3=2,655\text{In-lb} < 10,849\text{In-lb}$

(Allowable acc./dec. torque for RV-50C)

● Determine emergency stop and external shock torque

$T_{em}=15,045\text{In-lb} < 21,699\text{In-lb}$

(Momentary max. allowable torque for RV-50C)

$$C_{em} = \frac{775 \times \left(\frac{5 \times 4,340}{15,045} \right)^{10}}{40 \times \frac{20}{60} \times 0.05} = 3,941 \text{ times}$$

Determine main bearing capacity

● External load condition

$W_1=550\text{lbs}$ $l_1=19.7\text{in.}$

$W_2=220\text{lbs}$ $l_3=7.9\text{in.}$

● Determine moment rigidity

● Determine whether output shaft deflection angle meets required specification value.

$$\theta = \frac{550 \times 19.7 + 220 \times 7.9}{17,346} = 0.72(\text{arc.min.})$$

● Determine external moment

$$l_2 = 19.7 + \frac{7.37}{2} = 23.39\text{in.}$$

$$M_c = 550 \times 23.39 + 220 \times 7.9 = 14,603\text{In-lb} < 15,623\text{In-lb}$$

(Allowable moment of RV-50C)

Since all required specification are satisfied, select RV-50C.

5-2 Strength and service life

5-2-1 Allowable torque during acceleration or deceleration

When the Machine starts (or stops), a larger torque than the steady-state torque is applied to the reduction gear because of the inertial loads. The values in the rating table (see page 57) show the allowable value of the peak torque when the reduction gear starts or stops.

The allowable acceleration/deceleration torque is 250% of the rated torque.

5-2-2 Momentary maximum allowable torque

A large torque during an emergency stop or external shock may be applied to the reduction gear. The maximum allowable torque is shown in the ratings table(see page 57).

Momentary maximum allowable torque is 500% of the rated torque.

Note)When shock torque is applied, be sure to use at or below the limit cycle (refer to selection flowchart on page 59).

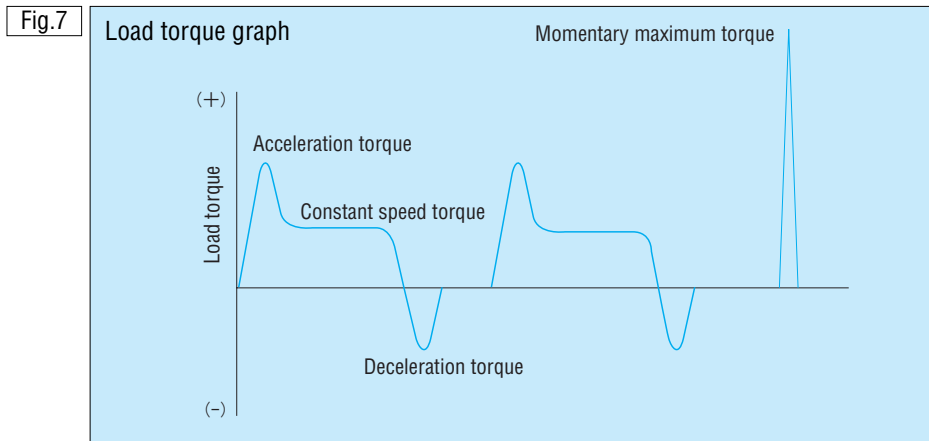

5-2-3 Rated service life

The service life of the RV-C reduction gear is based on the life of the roller bearings of the crankshafts. The service life is set as shown in Table 3 for all models and ratios at rated torque and at rated output speed.

Table 3	L_h	Service life (Hrs)	
	L_{10}	K	6,000

When in actual service installed in the equipment, calculate the service life using the following formula because the load condition depends on the types of reduction gear.

$$L_h = K \times \frac{N_o}{N_m} \times \left(\frac{T_o}{T_m} \right)^{\frac{10}{9}}$$

L_h : Service life to be obtained (Hr)
 N_m : Average output speed (r/min) (calculation on page 59)
 T_m : Average output torque (In-lb) (calculation on page 59)
 N_o : Rated output speed (r/min) (table 4)
 T_o : Rated output torque (In-lb) (table 4)

Table 4	Type	Rated torque In-lb(Nm)	Rated output speed (N_o)
	RV-10C	868 (98)	15r/min
	RV-27C	2,347 (265)	
	RV-50C	4,340 (490)	
	RV-100C	8,679 (980)	
	RV-200C	17,368 (1,961)	
	RV-320C	27,774 (3,136)	
	RV-500C	43,397 (4,900)	

5-3 Capacity of main bearing

Angular contact ball bearings are incorporated in the RV-C Series reduction gears so that external loads may be supported. However, the RV-250C is not equipped with the built-in main bearings and users are requested to design external bearings.

5-3-1 Moment rigidity

When an external load is applied to the output shaft, its deflection angle is proportional to the external moment (where $l_2 > b$). The moment rigidity is expressed as an external moment value, which is required to deflect the output shaft 1 arc. min. (See Table 7.)

$$\theta = \frac{W_1 l_1 + W_2 l_3}{M_t}$$

θ : Deflected angle of output shaft (arc. min.)
 M_t : Moment rigidity (In-lb/arc.min.) (table 5)
 W_1, W_2 : Weight (lbs)
 l_1, l_3 : Arm length (in.)
 $l_1 = l + \frac{b}{2} - a$
 l : The distance between the output shaft mounting surface and the loading point (in.)

Fig.8 External loading diagram

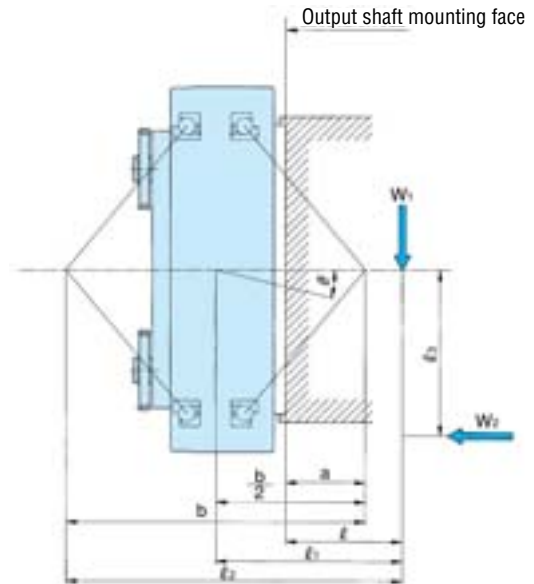

Model	Moment rigidity (Mt) In-lb/arc.min. Typical Value	Size (in.)	
		a	b
RV-10C	3,729	1.10	4.69
RV-27C	9,459	1.50	5.92
RV-50C	17,359	1.98	7.37
RV-100C	24,914	2.31	8.17
RV-200C	86,795	2.99	11.04
RV-320C	112,833	4.5	14.19
RV-500C	216,987	4.92	16.28

5-3-2 Allowable moment

Table 6 shows the external moment values (moments during starting and stopping, etc.) that can be supported by the RV-C Series.

Refer to figure 9 indicating the range of allowable moment for simultaneous application of external moment and external thrust.

$$M_c \leq \text{Allowable moment value}$$

$$M_c = W_1 l_2 + W_2 l_3 \quad (l_2 > b)$$

M_c : External moment (In-lb)
 W_1, W_2 : Load (lb)
 l_2, l_3 : Distance to load point (in.)
 $l_2 = l + b - a$
 l : Distance from output shaft mounting face to load point (in.)

Model	Allowable moment In-lb(Nm)	Allowable thrust lbs(N)
RV-10C	6,076 (686)	1,323 (5,880)
RV-27C	8,679 (980)	1,984 (8,820)
RV-50C	15,623 (1,764)	2,646 (11,760)
RV-100C	21,699 (2,450)	3,086 (13,720)
RV-200C	78,115 (8,820)	4,409 (19,600)
RV-320C	182,269 (20,580)	6,614 (29,400)
RV-500C	303,781 (34,300)	8,818 (39,200)

Fig.9 Allowable moment diagram

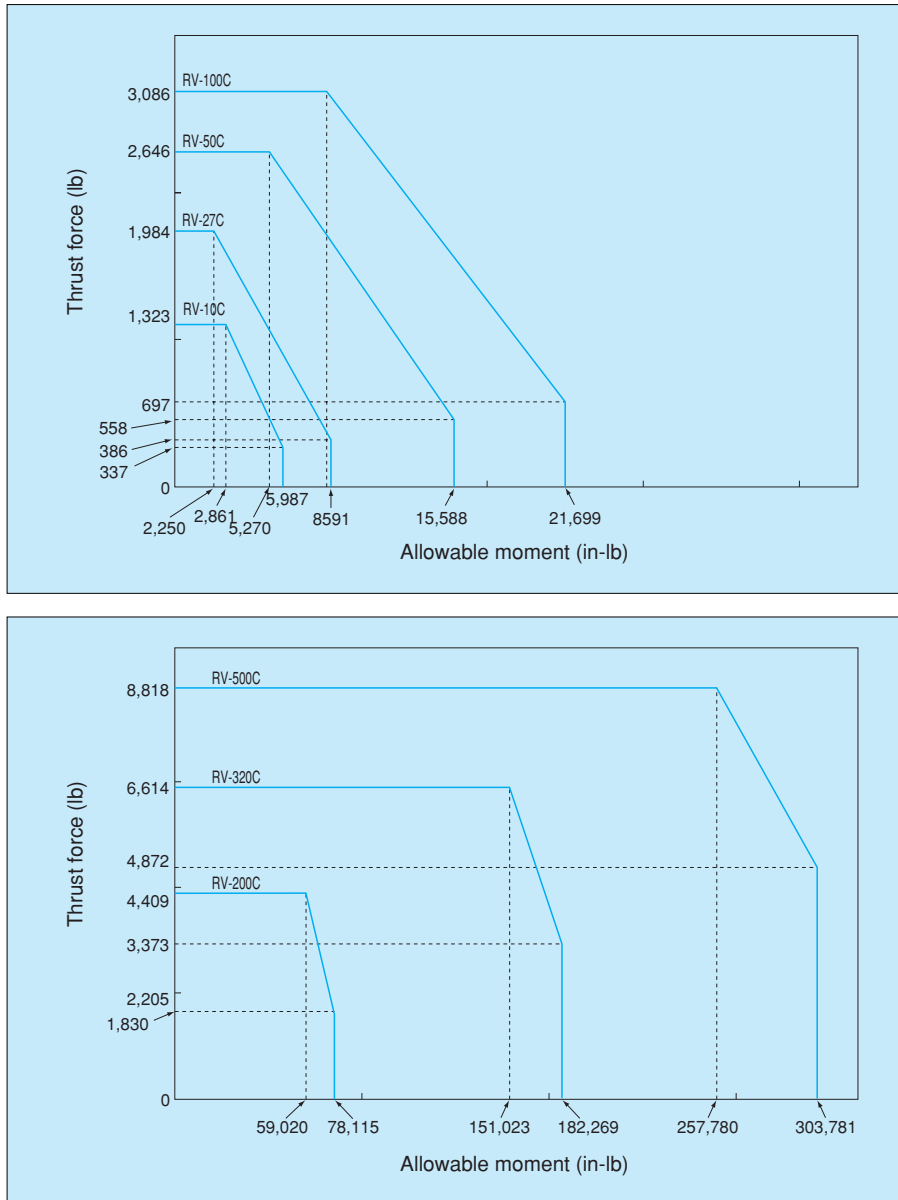

5-3-3 Momentary maximum allowable moment

A large torque and moment due to emergency stop or external impact may be applied to the reduction gear.

The rating table (page 57) shows the momentary maximum allowable moment values.

The momentary maximum allowable moment is twice the allowable moment.

6 PERFORMANCE CHARACTERISTICS

6-1 Rigidity (Torsional rigidity and lost motion) and backlash

When a torque is applied to the output shaft while the input shaft (center gear) is fixed, torsion is generated according to the torque value and a hysteresis curve result is shown in Fig. 10.

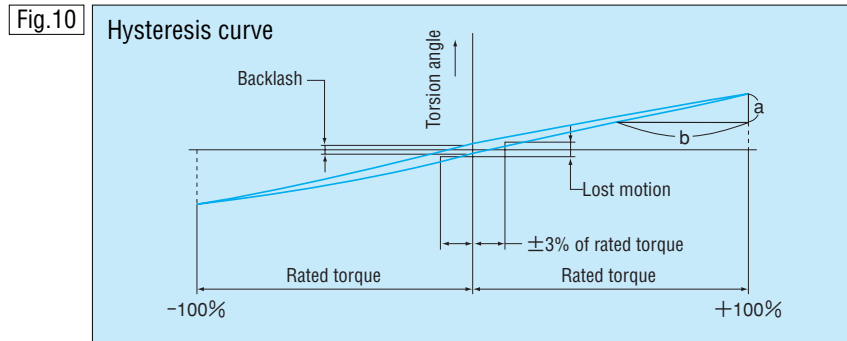

The rigidity of the reduction gear is expressed by the torsional rigidity and the lost motion in this curve. RV reduction gears are especially superior in their stiffness characteristics.

- Torsional rigidity = $\frac{b}{a}$
- Lost motion
The torsion angle at the mid point of the hysteresis curve width at $\pm 3\%$ of rated torque.
- Backlash
The torsion angles when the torque indicated by the hysteresis curve is zero.

6-1-1 Calculation of torsion (an example)

Take an example of the RV-100C and find a torsion where a torque is applied in one direction.

1) If a torque of 88.6 In-lb is applied, the resulting torsion ST_1 , is found as shown below.

- Note that the torque is in the lost motion range.

$$ST_1 = \frac{88.6}{260.4} \times \frac{1(\text{arc.min.})}{2} = 0.17 \text{ arc.min.}$$

2) If a torque of 5,314 In-lb is applied, the resulting torsion ST_2 is found as shown below.

- Note that the torque is in the rated torque range.

$$ST_2 = \frac{1}{2} + \frac{5,314 - 260.4}{4,517} = 1.62 \text{ arc.min.}$$

Note: The above torsion value is that of the reduction gear assembly.

Table 7

Model	Torsional rigidity In-lb/arc.min.	Lost motion		Backlash arc.min.
		Lost motion arc.min.	Measured torque in-lb	
RV-10C	416	MAX1	± 26.0	MAX1
RV-27C	1,302		± 70.3	
RV-50C	2,258		± 130.2	
RV-100C	4,517		± 260.4	
RV-200C	8,679		± 520.8	
RV-320C	17,359		± 833.4	
RV-500C	30,378		± 1301.9	

6-2 Vibration

The vibration is a torsional vibration in the circumferential direction when driven by a servomotor with an inertia load applied.

The vibration is one of the most important characteristics, especially when precise contouring control is required. For example, the industrial robot requires exact and smooth contour control for its longer arm. An actual measured example of the vibration characteristics is shown in Fig. 11.

Fig.11

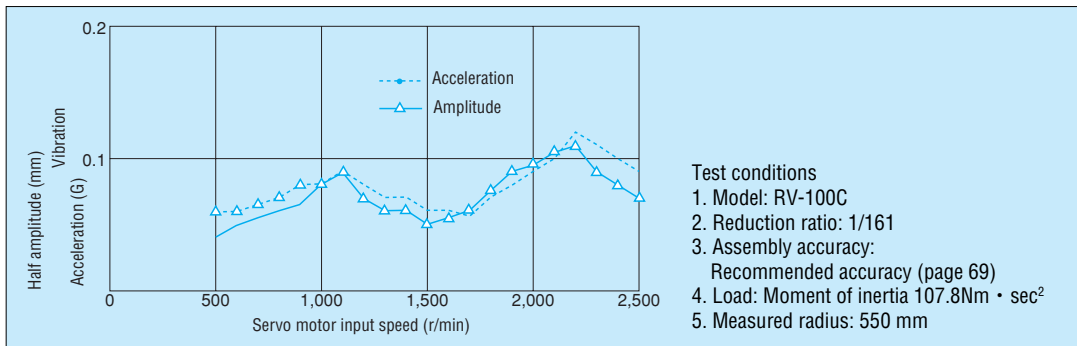

6-3 Angular transmission accuracy

Angular transmission accuracy refers to a difference between the theoretical output revolution angle and the actual revolution angle (θ out) when any revolution angle (θ in) is the input, and is expressed as an angular transmission error (θ er). The angular transmission error is found in the following equation.

$$\theta_{er} = \frac{\theta_{in}}{R} - \theta_{out} \text{ (where } R = \text{reduction ratio)}$$

The measured example is shown below.

Fig.12

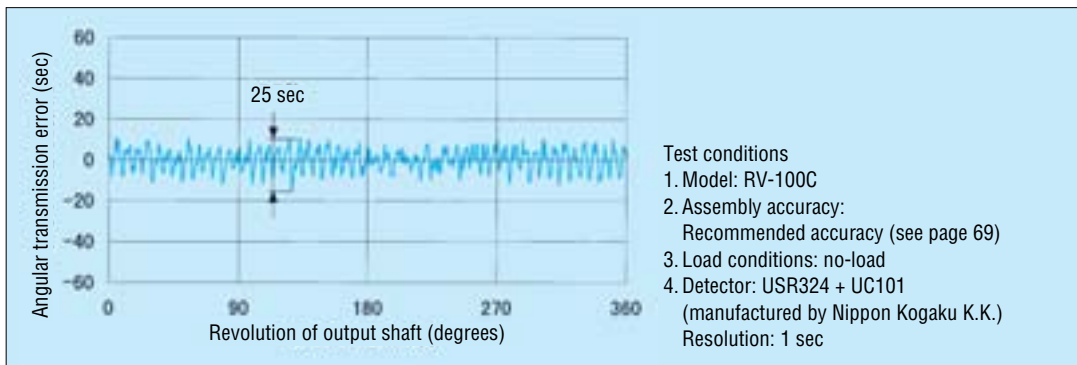

6-4 No-load running torque

The no-load running torque means a torque required on the input shaft (center gear) side in order to rotate the RV-C reduction gear under no load. Fig. 13 shows the no-load running torque on the output shaft side, which is converted from the no-load running torque according to the following equation.

● No-load running torque converted to motor shaft (In-lb)

$$T_M = T_L \times \frac{Z_1}{Z_2} + \text{frictional resistance of center gear}$$

Z_1 : Number of teeth on input gear
 Z_2 : Number of teeth on large center gear

$$T_L = \frac{\text{Converted torque on the output shaft side (In-lb)}}{R} \quad (\text{where } R = \text{speed ratio of RV reduction gear})$$

Note: The diagram below shows average values obtained after a RV-C reduction gear has been run in. The agitation resistance of center gear is not included in the values.

Fig.13

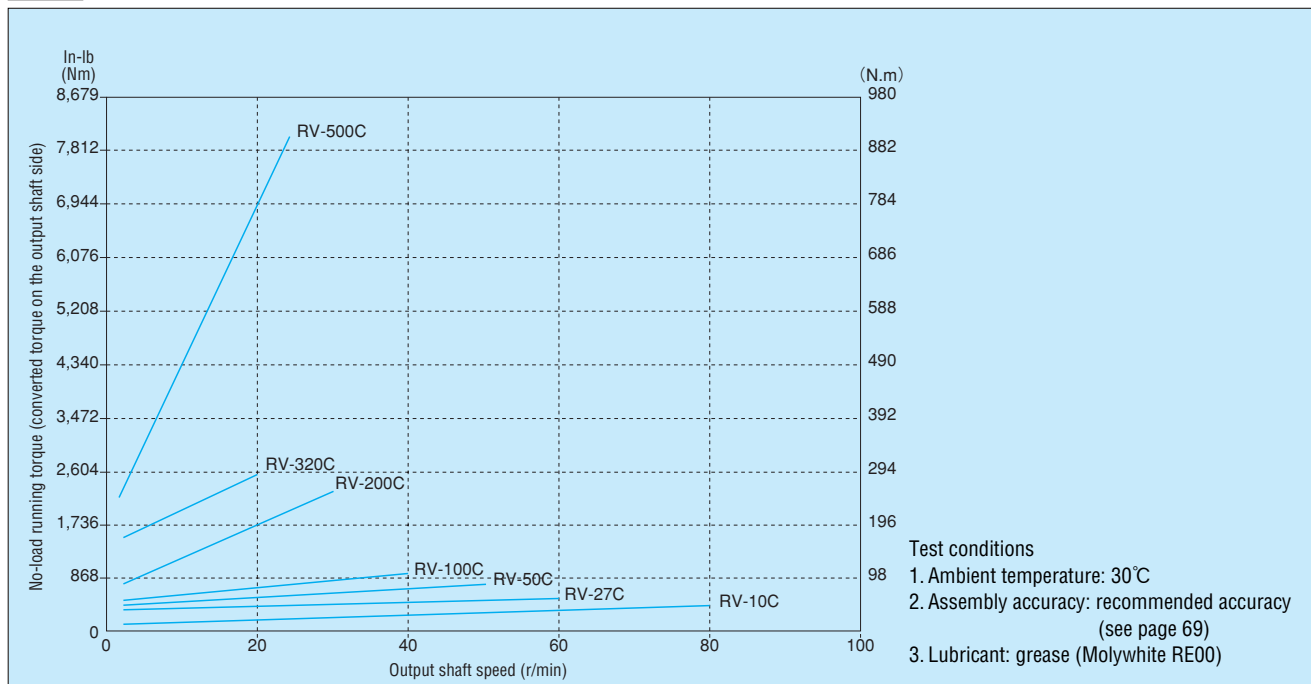

6-5 Backdriving torque

The backdriving torque refers to a torque required for starting the output shaft, with the RV-C reduction gear left under no-load. If the input shaft (input gear) is released while a torque equal to or more than the backdriving torque is kept applied to the output shaft, the input shaft (center gear) starts running at an augmented speed. Special care should be given to the backdriving torque to start the RV-C reduction gear.

Table 8

Model	Backdriving torque In-lb(Nm)
RV-10C	89 (10)
RV-27C	461 (52)
RV-50C	841 (95)
RV-100C	1,063 (120)
RV-200C	1,328 (150)
RV-320C	1,948 (220)
RV-500C	2,657 (300)

Test conditions
 Assembly accuracy: recommended accuracy
 (see page 69)
 Lubricant: grease (Molywhite RE00)

6-6 Low-temperature Characteristics (No-load running torque under low temperature)

Test conditions

1. Assembly accuracy: recommended accuracy (page 69)
2. Lubricant: grease (Molywhite RE00)
3. Input speed: 15 r/min
4. Loss at center gear is not included.

When the RV-C reduction gear is used under a low temperature, viscosity of lubricant increases and causes a larger no-load running torque. The no-load running torque under low temperature is shown below.

Fig.14

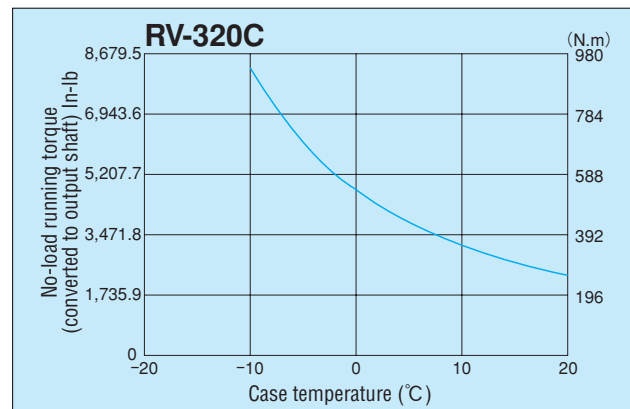
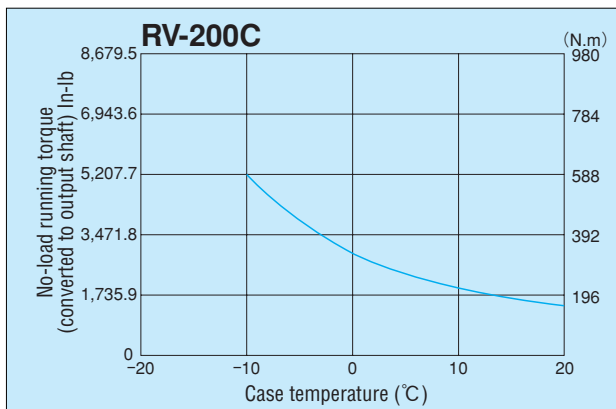
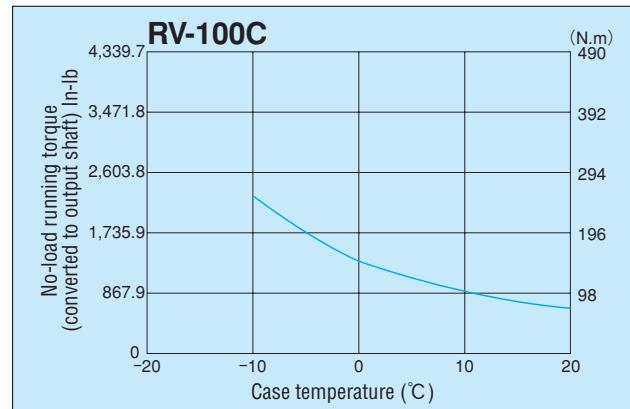
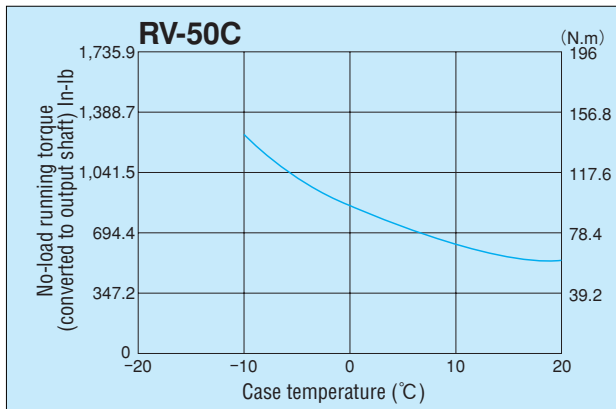
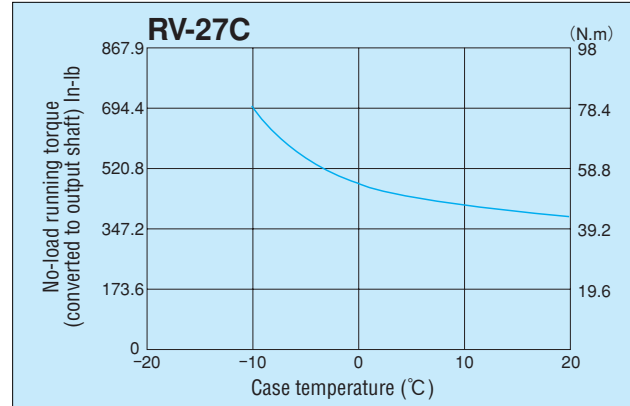
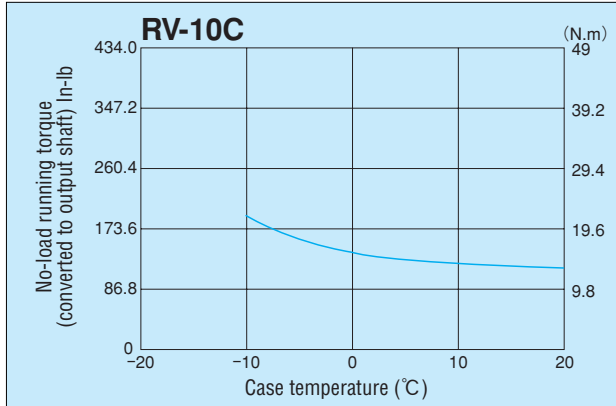

※Please inform Nabtesco if you have a plan to use the RV-500C in cold temperature environment.

6-7 Efficiency charts

Test conditions

1. Case temperature: 30°C
2. Assembly accuracy: recommended accuracy (page 69)
3. Lubricant: grease (Molywhite RE00)
4. Loss at center gear is not included.

Fig.15

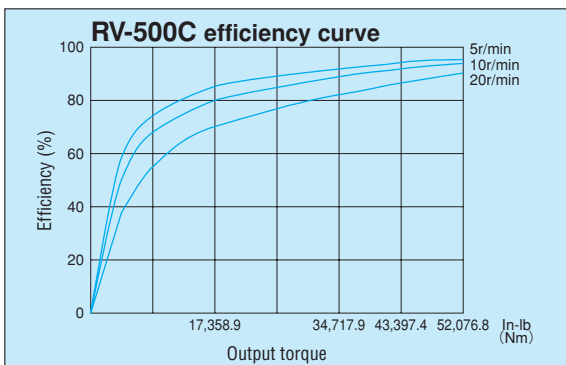
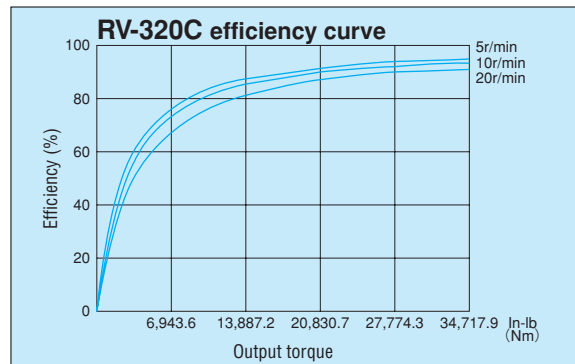
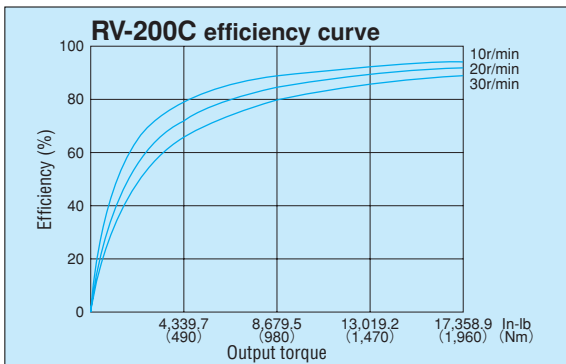
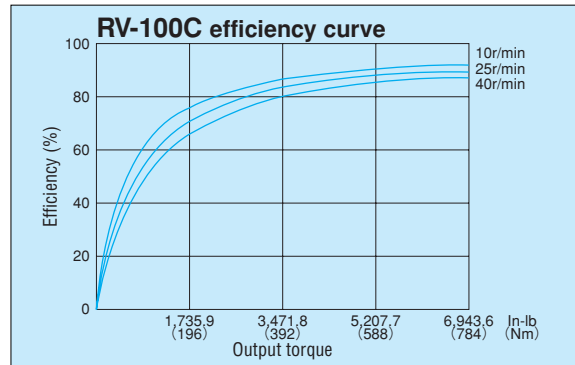
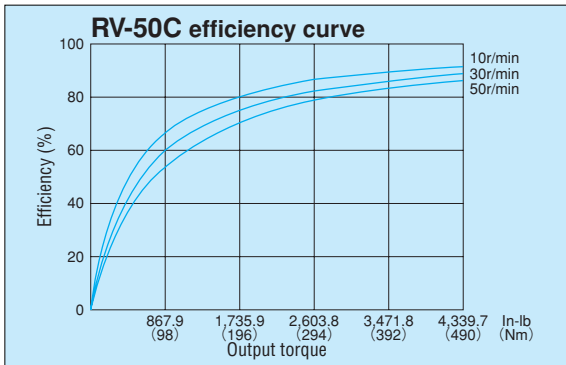
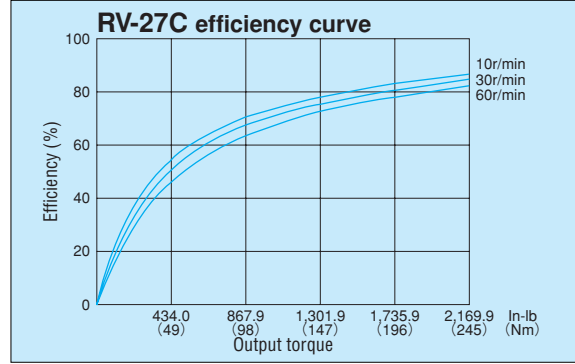
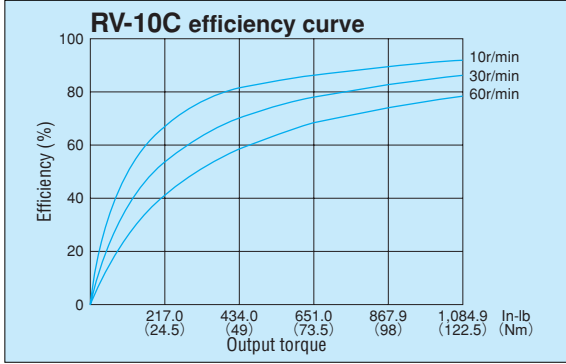

RV-C series

7 INSTALLATION AND ASSEMBLY

To get maximum performance from RV-C reduction gears, it is important to pay attention to the assembly accuracy, installation, lubrication and sealing. Angular ball bearings are used as the main bearings with RV-C Series reduction gears. When designing the layout, make sure the bearing retainer will not touch the motor mounting flange. Refer to the outline drawings on the pages after page 78.

Note: Two types of RV-C are available: bolt clamping output shaft type (refer to pages 77 to 83 for outline drawings, and through bolt clamping output shaft type (refer to pages 84 to 89 for outline drawings excluding RV-500C). Please be sure to specify when ordering.

7-1 Assembly accuracy

Design the assembly side of the RV-C reduction gear within tolerances shown in Table 9. Poor assembly accuracy causes vibration and particularly noise or backlash.

7-1-1 Assembly accuracy

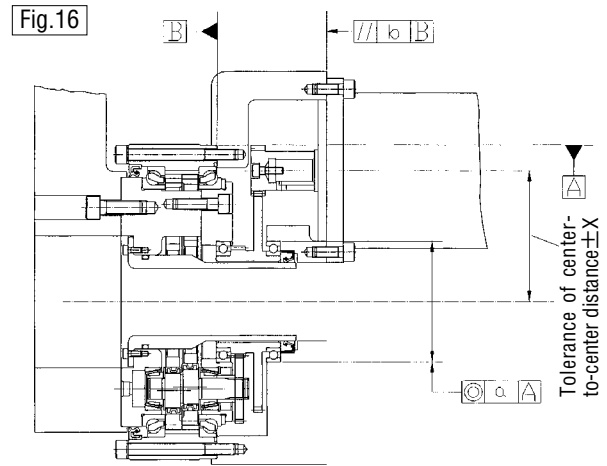

R indicates distance from center of reduction gear to center of motor.

Table 9

(Unit:mm)

Model	Tolerance of center-to-center distance X	Concentricity tolerance a	Tolerance of parallelism b
RV-10C	±0.03	MAX0.03	MAX0.03
RV-27C			
RV-50C			
RV-100C			
RV-200C			
RV-320C			
RV-500C			

7-2 Installation procedure

- The typical installation examples for RV-C reduction gears are shown below. Be sure to seal the designated type of grease to the designated level. (See page 75)
Slow speed tube and the output surface of the RV-C reduction gear need to be sealed.
- Be sure that seals are used between mating parts on the input side. Refer to the O-ring seal installation illustrated.
- If the use of an O-ring seal is impossible because of the design, use Gasket sealant. See table 10 at right.

7-2-1 Assembly example of center tube

The center tube is used to protect the cable which runs through the hollow section and to seal grease filled in the reduction gear. The assembly example of center tube is shown in Fig.18 for reference.

Table 10 Recommended Gasket sealant

Manufacturer	Name
Loctite	5699 Grey High Performance RTV Silicone Gasket Maker
Permatex	Moto Seal 2 Ultimate Gasket Maker White

Notes 1. Do not use for copper material or copper alloy material.
2. If it is used under special conditions such as concentrated alkali, pressurized steam, etc., please contact Nabtesco.

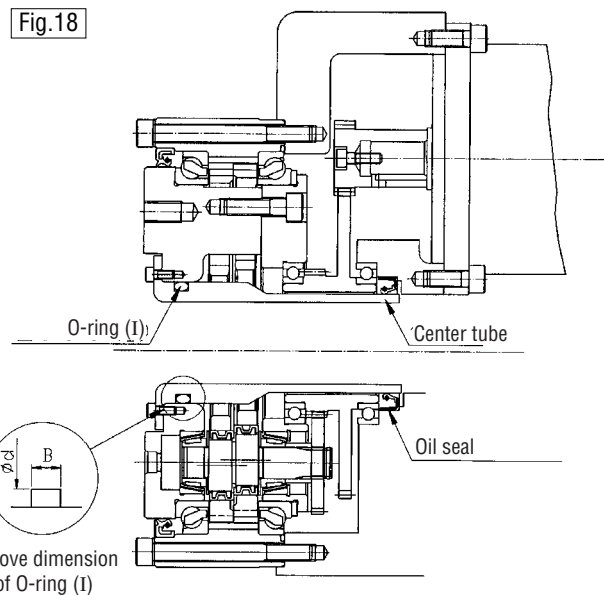

Table 11 Dimensions of O-ring (I) seal (for reference)

(Unit:mm)

		RV-10C	RV-27C	RV-50C	RV-100C	RV-200C	RV-320C	RV-500C
Dimensions Groove size	O-ring	ID number	CO 0625	CO 0634	CO 0643	CO 0546A	G95 (Metric)	G135 (Metric)
		Wire dia.	ϕ 2.4 \pm 0.07	←	ϕ 3.5 \pm 0.1	ϕ 2.0 \pm 0.1	ϕ 3.1 \pm 0.1	←
		I. D.	ϕ 29.7	ϕ 42.2	ϕ 59.6	ϕ 69.5	ϕ 94.4	ϕ 134.4
		I. D.: d	ϕ 30.2 $-\frac{0}{0.08}$	ϕ 43.2 $-\frac{0}{0.08}$	ϕ 60.3 $-\frac{0}{0.10}$	ϕ 70.0 $-\frac{0}{0.05}$	ϕ 95.0 $-\frac{0}{0.10}$	ϕ 135.0 $-\frac{0}{0.08}$
		Width: B	3.2 $+\frac{0}{0.25}$	←	4.7 $+\frac{0}{0.25}$	2.7 $+\frac{0}{0.25}$	4.1 $+\frac{0}{0.25}$	←

7-2-2 Assembly example with the output shaft bolt clamping type

If center tube, oil seal and O-ring (I) are used together, the seal on the mounting surface of output shaft side is not required.

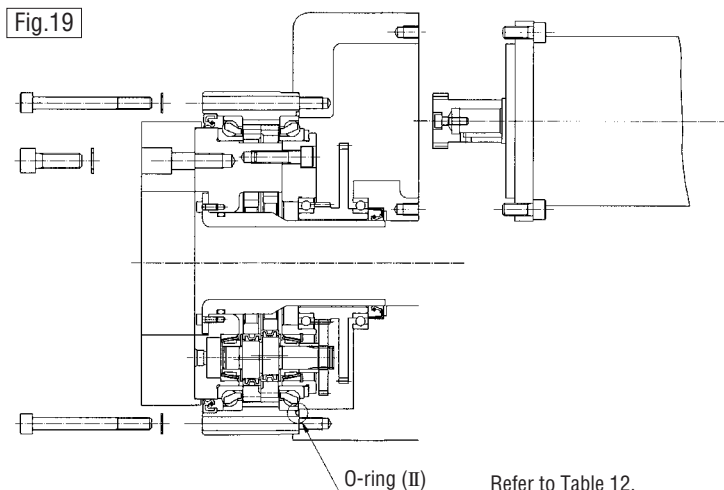

Table 12 O-ring (II)

	Applicable O-ring seal
RV-10C	AS568-048
RV-27C	AS568-163
RV-50C	AS568-169
RV-100C	AS568-173
RV-200C	AS568-277
RV-320C	AS568-281
RV-500C	G460 (Metric)

The O-ring (II) can be applied to both bolt clamping and through-bolt clamping output shaft types.

Refer to Table 12.

7-2-3 Assembly example of through-bolt clamping output shaft type (RV-27C, 50C, 100C and 200C)

The O-ring groove is provided at the end face of output shaft of the reduction gear. Use O-rings as shown below.

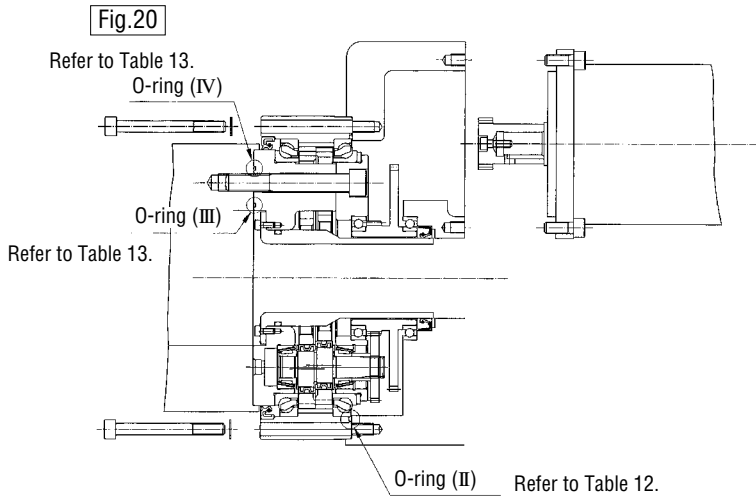

Table 13

	Applicable O-ring (III)	Applicable O-ring (IV)
RV-27C	S75 (Metric)	S120 (Metric)
RV-50C	S100 (Metric)	S150 (Metric)
RV-100C	G115 (Metric)	AS568-165
RV-200C	S150 (Metric)	AS568-271

7-2-4 Assembly example of through-bolt clamping output shaft type (RV-10C and 320C)

Provide the O-ring groove on the counterpart component. Dimensions of O-rings are shown below for reference.

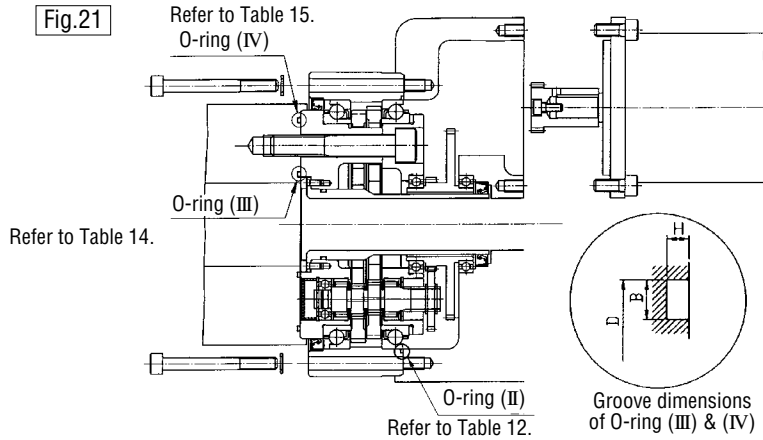

Table 14 O-ring(III) seal dimensions (for reference) (Unit:mm)

		RV-10C	RV-320C
Dimensions	O-ring	ID number	AS568-032
		Wire dia.	ϕ 1.78 \pm 0.07
	Groove size	I. D.	ϕ 47.35 \pm 0.38
		O. D.: d	ϕ 51.0 $^{+0.05}_0$
		Depth: H	1.27 \pm 0.05
		Width: B	2.39 $^{+0.25}_0$

Table 15 O-ring(IV) seal dimensions (for reference) (Unit:mm)

		RV-10C	RV-320C
Dimensions	O-ring	ID number	S100 (Metric)
		Wire dia.	ϕ 2.0 \pm 0.1
	Groove size	I. D.	ϕ 99.5 \pm 0.4
		O. D.: d	ϕ 103.0 $^{+0.05}_0$
		Depth: H	1.5 $^{0}_{-0.1}$
		Width: B	2.7 $^{+0.25}_0$

Notes: "G", "S" Part numbers are Japanese Industrial Standard (JIS B 2401) Metric O-Rings
"CO" Part numbers are NOK's.

7-3 Center gear and input gear

7-3-1 Accuracy of center gear and input gear

Poor installation accuracy of center gear and input gear may cause noise and backlash, so design center gear and input gear to the following tolerances.

Table 16 Accuracy of center gear and input gear

(Unit:mm)

Tolerance of fitting X	Tolerance of concentricity a	Tooth grade of small center gear	Tooth grade of large center gear	Tooth grade of input gear
h6	MAX0.03	JIS 5 class	JIS 4 class	JIS 5 class

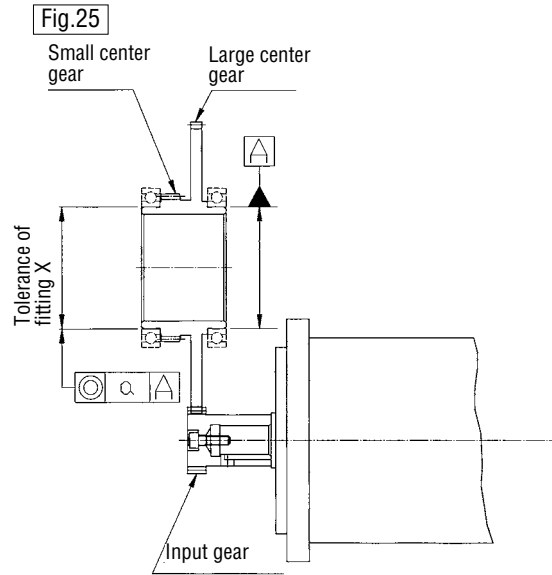

Table 17

(Unit:mm)

	Backlash between input gear and large center gear
RV-10C	0.035~0.090
RV-27C	0.040~0.110
RV-50C	0.050~0.130
RV-100C	0.060~0.140
RV-200C	0.075~0.180
RV-320C	
RV-500C	

Table 18 Specifications of small center gear tooth

	Module	Number of teeth	Addendum modification coefficient
RV-10C	1.0	48	-0.04
RV-27C	1.0	57	+0.2
RV-50C	1.25	61	0
RV-100C	1.75	48	+0.3
RV-200C	2.5	43	0
RV-320C	2	78	0
RV-500C	2	83	0

7-3-2 Standard center gear

The standard center gears for RV-C reduction gear are available from Nabtesco.

If the standard center gear is needed, please specify when ordering. Specifications of standard large center gears are shown below. Refer to the external dimension for installation.

Table 19 Specifications of standard large center gear

	Module	Number of teeth	Addendum modification coefficient
RV-10C	2	57	0
RV-27C	1.25	78	0
RV-50C	2	78	0
RV-100C	1.75	112	0
RV-200C	2	110	0
RV-320C	2	125	0

7-4 Bolt tightening torque and allowable transmission torque

Use hexagonal socket bolts to assemble the RV-C reduction gear and tighten to the torque as specified below. When the pin/bolt mounting output shaft type is used, also use the taper pin. The serrated lock washer is recommended to prevent the bolt from loosening and protect the bolt seat face from flaws.

Table 20 Bolt tightening torque and tightening force

Hexagonal socket bolt nominal size x pitch (mm)	Tightening torque In-lb(Nm)	Tightening force (R) N	Bolt specification
M5 ×0.8	80 ±4 (9.01 ±0.49)	9,310	<ul style="list-style-type: none"> ●Hexagonal socket bolt JIS B 1176 ●Strength class JIS B 1051 12.9 ●Thread JIS B 0205 6g or class 2
M6 ×1.0	138 ±7 (15.6 ±0.78)	13,180	
M8 ×1.25	329 ±16 (37.2 ±1.86)	23,960	
M10×1.5	651 ±30 (73.5 ±3.43)	38,080	
M12×1.75	1,137 ±56 (128.4 ±6.37)	55,100	
M14×2.0	1,814 ±90 (204.8 ±10.2)	75,860	
M16×2.0	2,821 ±141 (318.5 ±15.9)	103,410	
M18×2.5	3,906 ±196 (441 ±22.1)	126,720	

Notes 1. The valves listed are for steel or cast iron material.

2. If softer material such as aluminum is used, limit the tightening torque. Also pay attention to the system torque requirements.

Calculation of allowable transmission torque of bolts

$$T_1 = F \times \frac{D_1}{2} \times \mu \times n_1$$

{

- T₁ : bolt allowable transmission torque (Nm)
- F : bolt tightening force (N)
- D₁ : bolt P.C.D. (m)
- μ : friction factor
 - μ = 0.15: where lubricants remained
 - μ = 0.2: where left dried with no lubricant
- n₁ : number of bolts

Serrated lock washer external teeth for hexagonal socket bolt

Material: steel
Hardness: HRC40~48

Fig.26

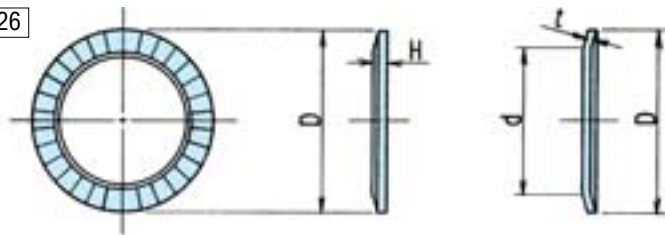

Table 21

Nominal size	O.D. and I.D. of washer		t	H
	d	D		
	Basic size			
5	5.25	8.5	0.6	0.85
6	6.4	10	1.0	1.25
8	8.4	13	1.2	1.55
10	10.6	16	1.5	1.9
12	12.6	18	1.8	2.2
14	14.6	21	2.0	2.5
16	16.9	24	2.3	2.8
18	18.9	27	2.6	3.15

Note: When using any equivalent washer, select it, with special care given to its outside diameter.

7-5 Installation of input gear

The profile of servomotor shaft and examples of input gear installation are shown below as a reference for designing. User must provide set screw, hexagonal socket bolt or hexagonal nut.

Straight shaft

(No female threaded on servomotor)

Fig.27

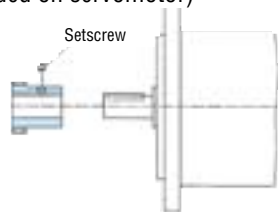

(With female threaded on servomotor)

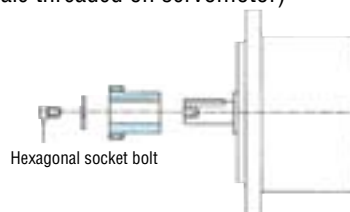

Taper shaft

(With male threaded on servomotor)

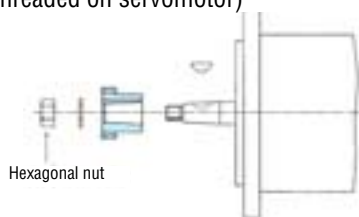

Note: A radial load due to the counterforce of torque is applied by the center gear on the RV-C reduction gear. Therefore, examine the strength of the motor shaft and the service life of bearings which support the motor shaft.

7-6 Lubrication

To maximize the performance of the RV-C reduction gear, the use of Molywhite RE00 manufactured by Nabtesco is recommended. Do not mix with other lubricants.

Table 22 Working temperature range (ambient temperature)

Working temperature range (ambient temperature)	-10°C ~ 40°C
---	--------------

Note: Please contact Nabtesco if grease or gear oil is to be used beyond the specified temperature range.

1) Grease level in RV-C reduction gear

The RV-C reduction gear when it is shipped from the plant is not greased. Therefore, ensure that the necessary amount of recommended grease is charged when installing the RV-C reduction gear.

Note: The quantity required for the RV-C reduction gear is shown below. The volume of grease listed below does not include the volume required to fill the shaded areas in figure 28. These areas must also be charged with grease. When there exists a cavity, such as when a slow-speed tube is being used, exclude the volume of such cavity.

However, too much filling may cause damage for an oil seal with increase of internal pressure. Please leave about 10% of the room inside.

Table 23 Horizontal installation

Type	Quantity	
	cc	(g)
RV-10C	147	(128)
RV-27C	266	(231)
RV-50C	498	(433)
RV-100C	756	(658)
RV-200C	1,831	(1,593)
RV-320C	2,880	(2,506)
RV-500C	5,934	(5,163)

Vertical installation

Type	Quantity	
	cc	(g)
RV-10C	167	(145)
RV-27C	305	(265)
RV-50C	571	(497)
RV-100C	857	(746)
RV-200C	2,076	(1,806)
RV-320C	3,191	(2,776)
RV-500C	6,900	(6,003)

2) Grease lubrication points

The RV-C reduction gear is provided with charging/discharging taps (or through holes) on the reduction gear unit (for details refer to the external dimension drawings). As an option these taps (or holes) can be covered with rubber caps (except RV-27C and RV-320C). This must be specified when ordering.

Horizontal installation

Fig.28

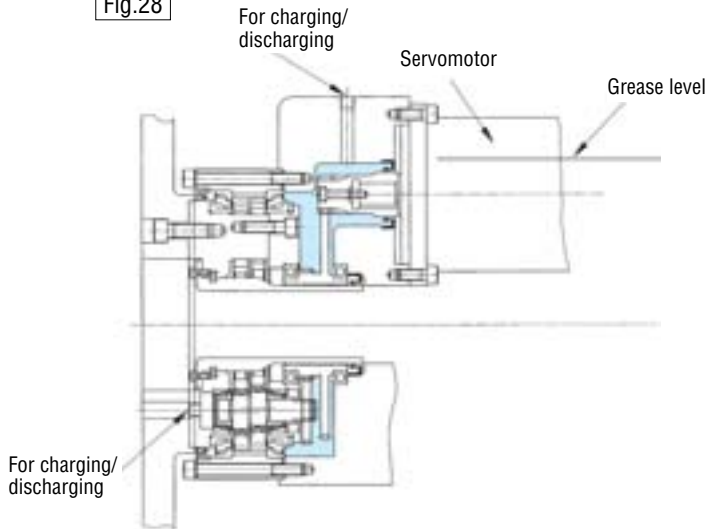

Vertical installation(1)

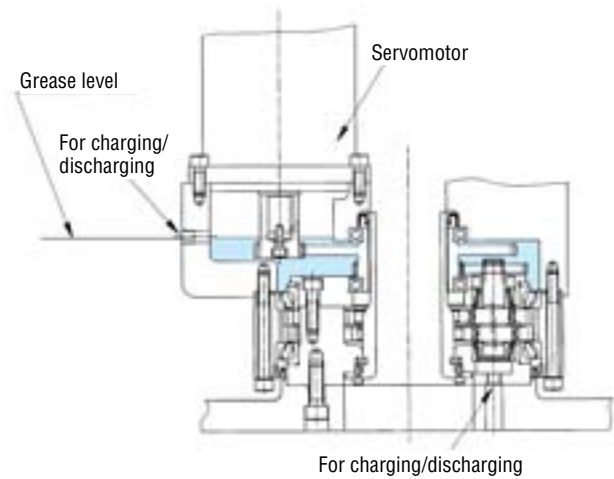

Vertical installation(2)

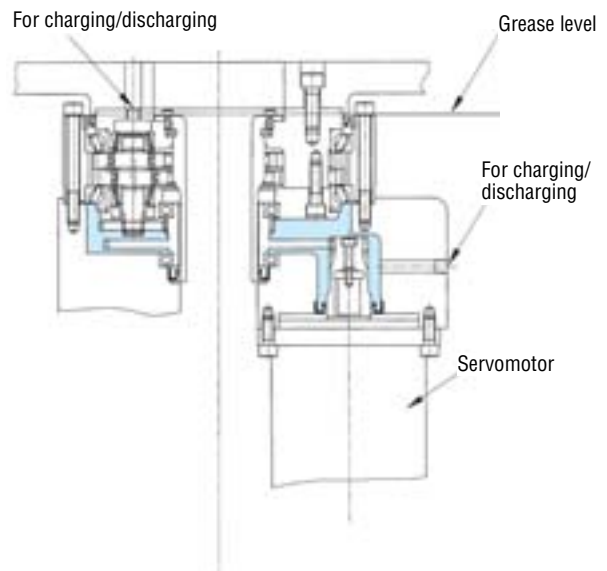

3) Interval between grease change

Change grease at a standard interval of 20,000 hours after initially supplying the RV-C reduction gear with grease in the specified quantity (see Fig.28) in order to protect the RV-C reduction gear from deteriorated grease.

If grease is contaminated for any reason or used at an ambient temperature of 40°C or more, check the grease for contamination or deterioration, to determine the proper maintenance interval.

7-7 Warranty

Nabtesco guarantees that the reduction gears of the model RV are free from defects of materials and workmanship.

The term of guarantee shall be one year after delivery or 2,000 hours of operation after the installation on an actual machine, whichever earlier, on condition that the product is operated under the rated operation conditions specified by us, in normal assembly and lubrication condition.

If any defect in materials or workmanship is detected during the above guarantee term, the product will be repaired or substituted at our expense, provided that the No. of man-hour required for demounting and remounting the product from the machine, transportation expense for re-delivery, warehousing and other incidental expenses shall be excluded from our obligation.

No expenses for damages of the machine due to shutdown of operation attributable to defect of the product are guaranteed.

If the guarantee is accomplished with money, the upper limit of the amount shall not exceed the selling price of that claimed product.

8-1 RV-10C External dimensions of bolt clamping output shaft type

Type code RV-10C-27-A-B

Speed ratio

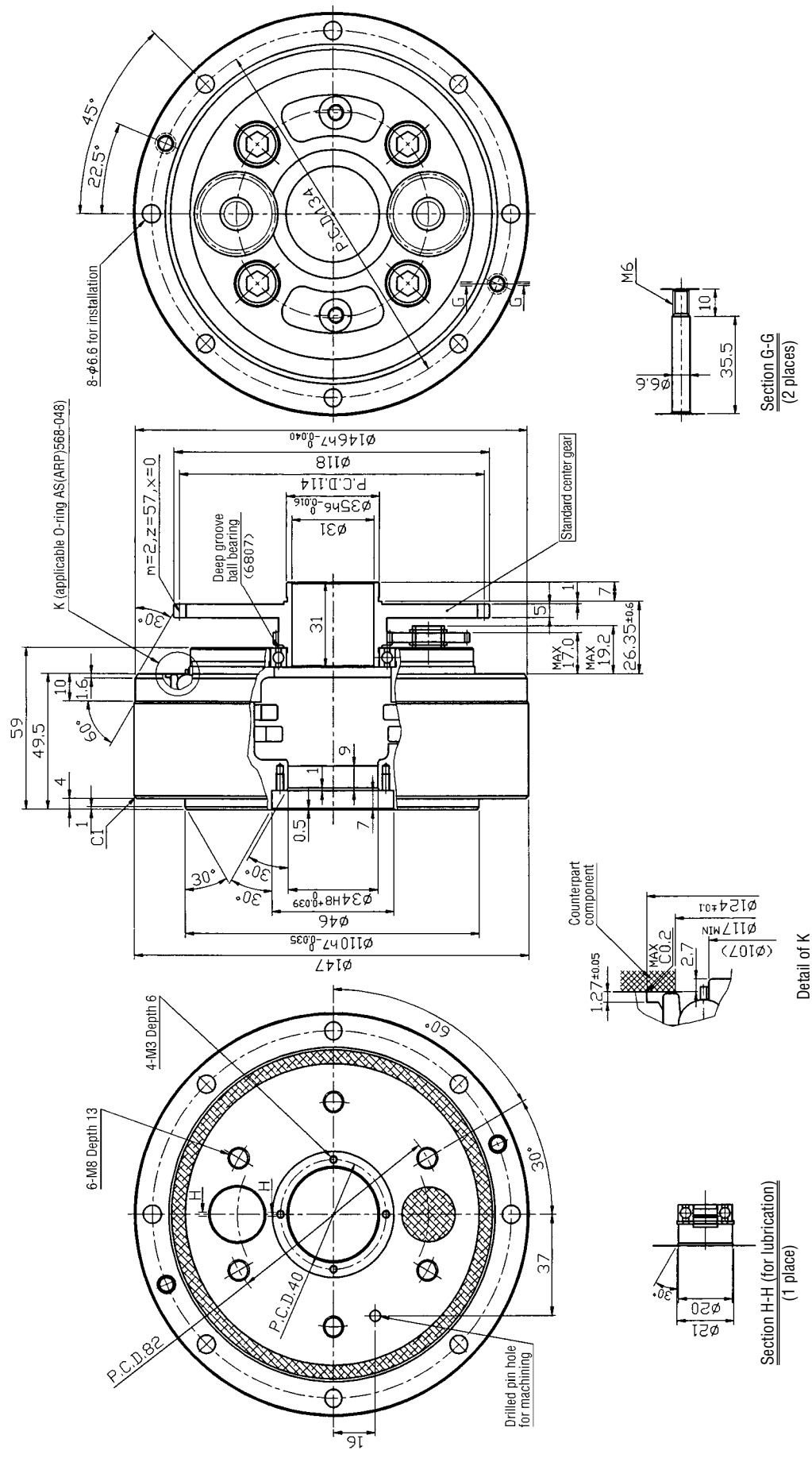

Allowable transmission torque

Number of bolts & Size	Allowable transmission torque
8-M6	1,058.4Nm
6-M8	882Nm

Notes 1. Use commercial goods to supply items such as O-rings, mounting bolts and seal washers.
2. Specifications and dimensions are subject to change without notice.

8-2 RV-27C External dimensions of bolt clamping output shaft type

Speed ratio

Type code RV-27C-36, 57-A-B

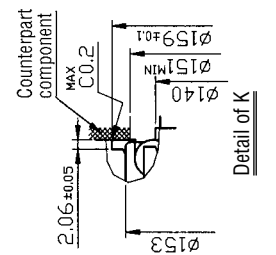
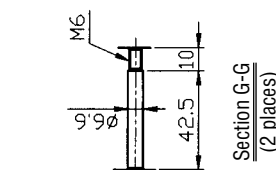
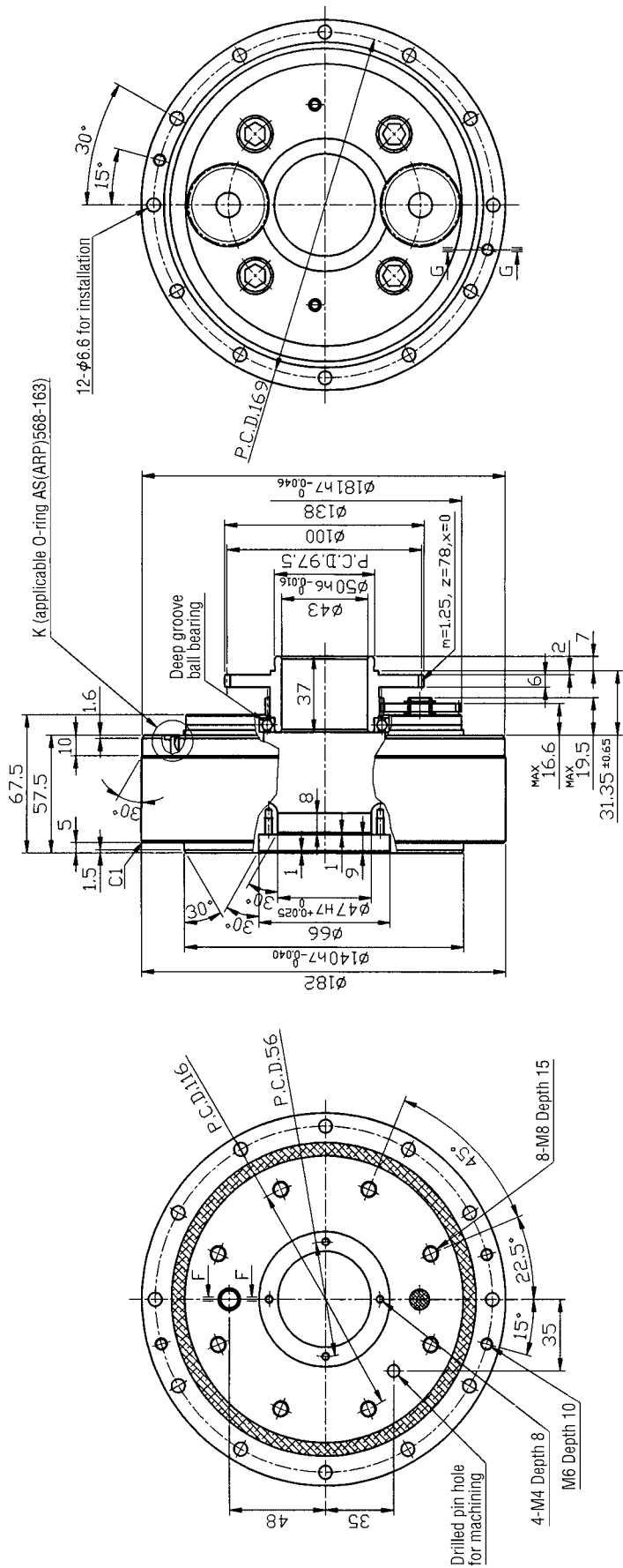

Allowable transmission torque

Number of bolts & size	Allowable transmission torque
12-M6	1,999.2Nm
8-M8	1,666Nm

- Notes 1. Use commercial goods to supply items such as O-rings, mounting bolts and seal washers.
- 2. Specifications and dimensions are subject to change without notice.

8-3 RV-50C External dimensions of bolt clamping output shaft type

Speed ratio
Type code RV-50C-32, 54 - A - B

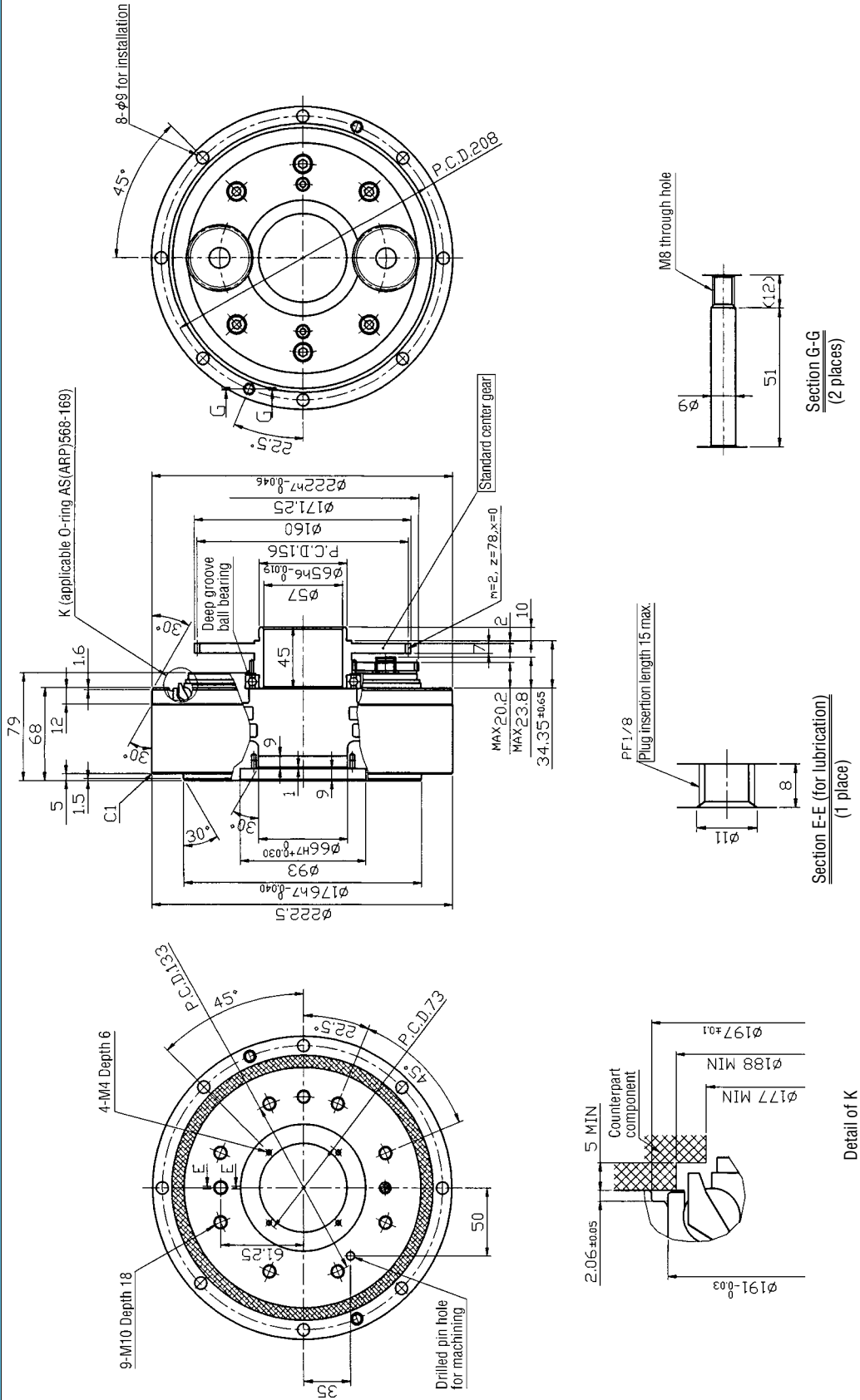

Allowable transmission torque

Number of bolts & Size		Allowable transmission torque
Case side	8-M8	2,989Nm
Shaft side	9-M10	3,410.4Nm

Notes 1. Use commercial goods to supply items such as O-rings, mounting bolts and seal washers.
2. Specifications and dimensions are subject to change without notice.

8-4 RV-100C External dimensions of bolt clamping output shaft type

Speed ratio

Type code RV-100C-**36, 75** - **A** - **B**

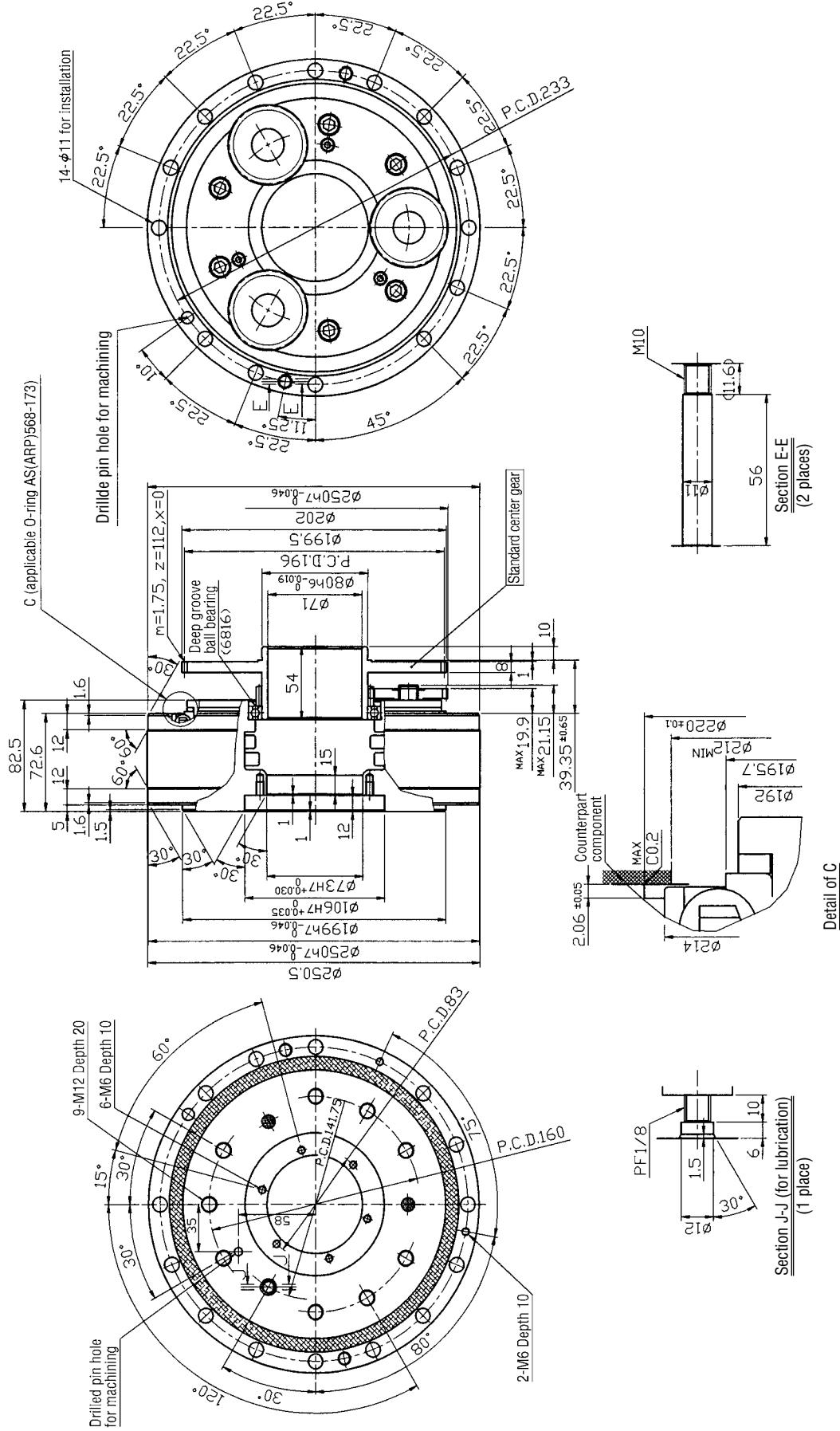

Allowable transmission torque

Number of bolts & size	Allowable transmission torque
Case side 14-M10	9,310Nm
Shaft side 9-M12	5,948.6Nm

- Notes 1. Use commercial goods to supply items such as O-rings, mounting bolts and seal washers.
 2. Specifications and dimensions are subject to change without notice.

8-5 RV-200C External dimensions of bolt clamping output shaft type

Speed ratio
Type code RV-200C-34, 86-A-B

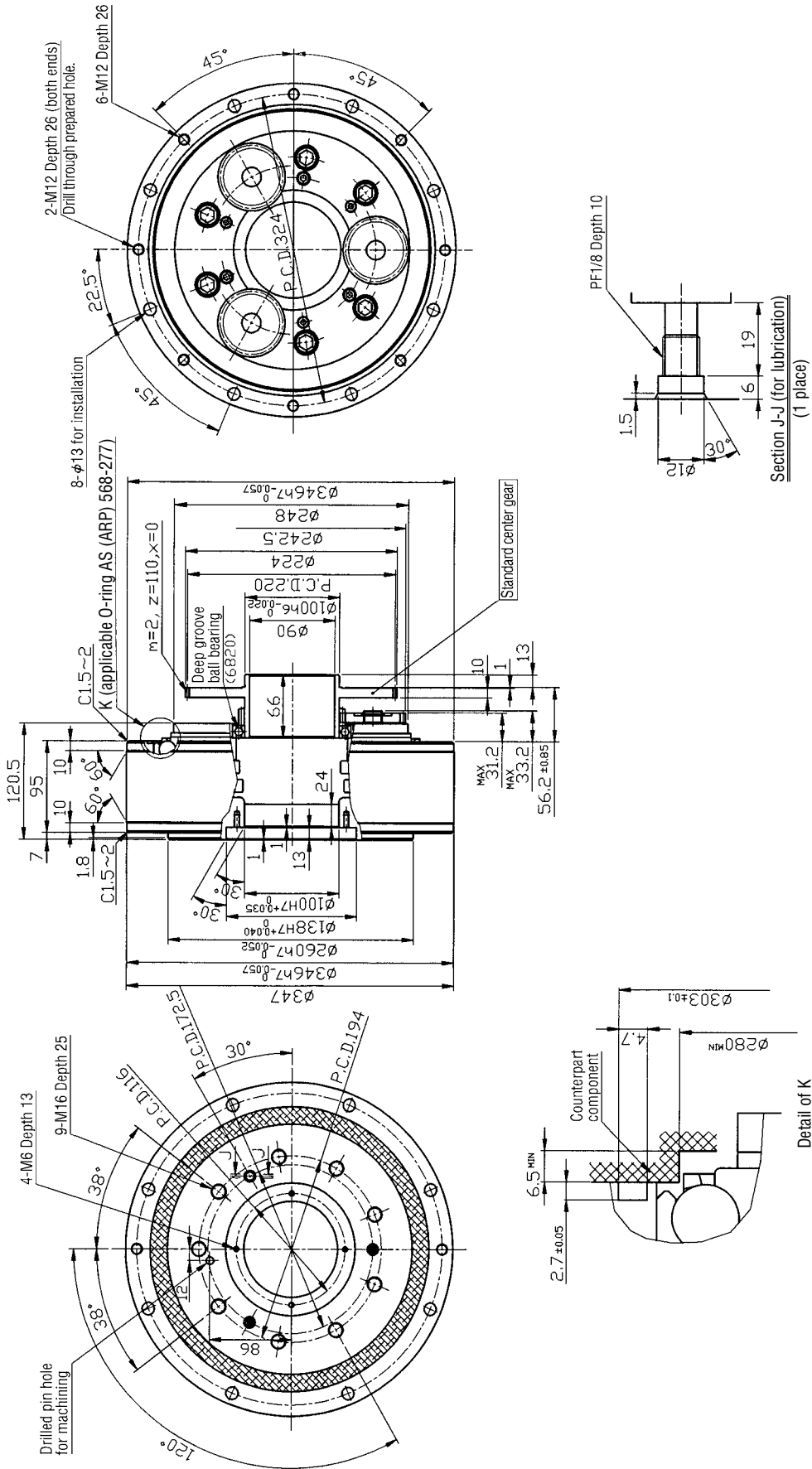

Allowable transmission torque

Number of bolts & Size		Allowable transmission torque
Case side	8-M12	10,701.6Nm
Shaft side	9-M16	13,543Nm

- Notes 1. Use commercial goods to supply items such as O-rings, mounting bolts and seal washers.
2. Specifications and dimensions are subject to change without notice.

8-6 RV-320C External dimensions of bolt clamping output shaft type

Speed ratio

Type code RV-320C-35, 61-A-B

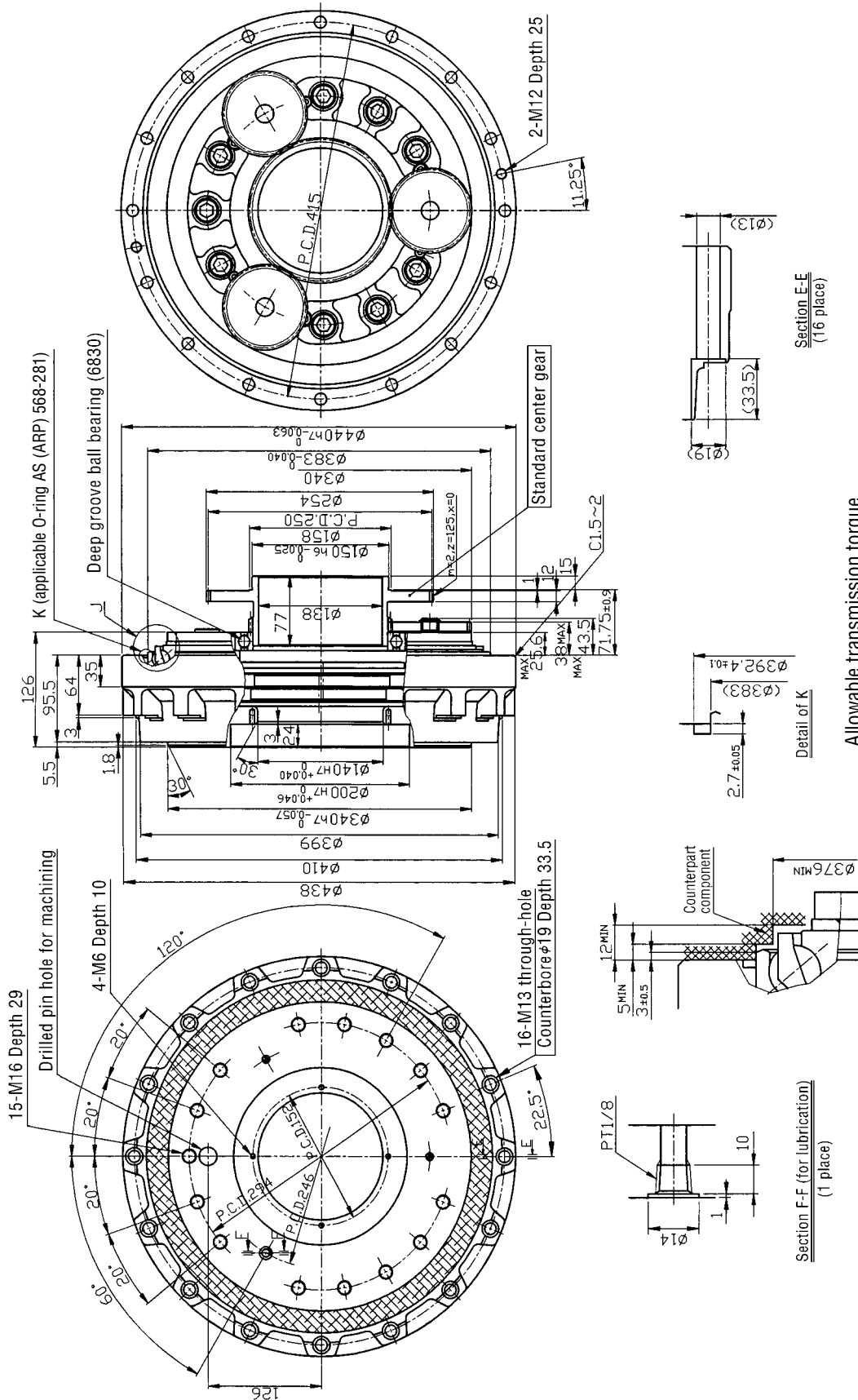

Allowable transmission torque

Number of bolts & size		Allowable transmission torque
Case side	16-M12	27,440Nm
Shaft side	15-M16	34,202Nm

Notes 1. Use commercial goods to supply items such as O-rings, mounting bolts and seal washers.
2. Specifications and dimensions are subject to change without notice.

8-7 RV-500C External dimensions of bolt clamping output shaft type

Speed ratio
Type code RV-500C-37.34-Z-B

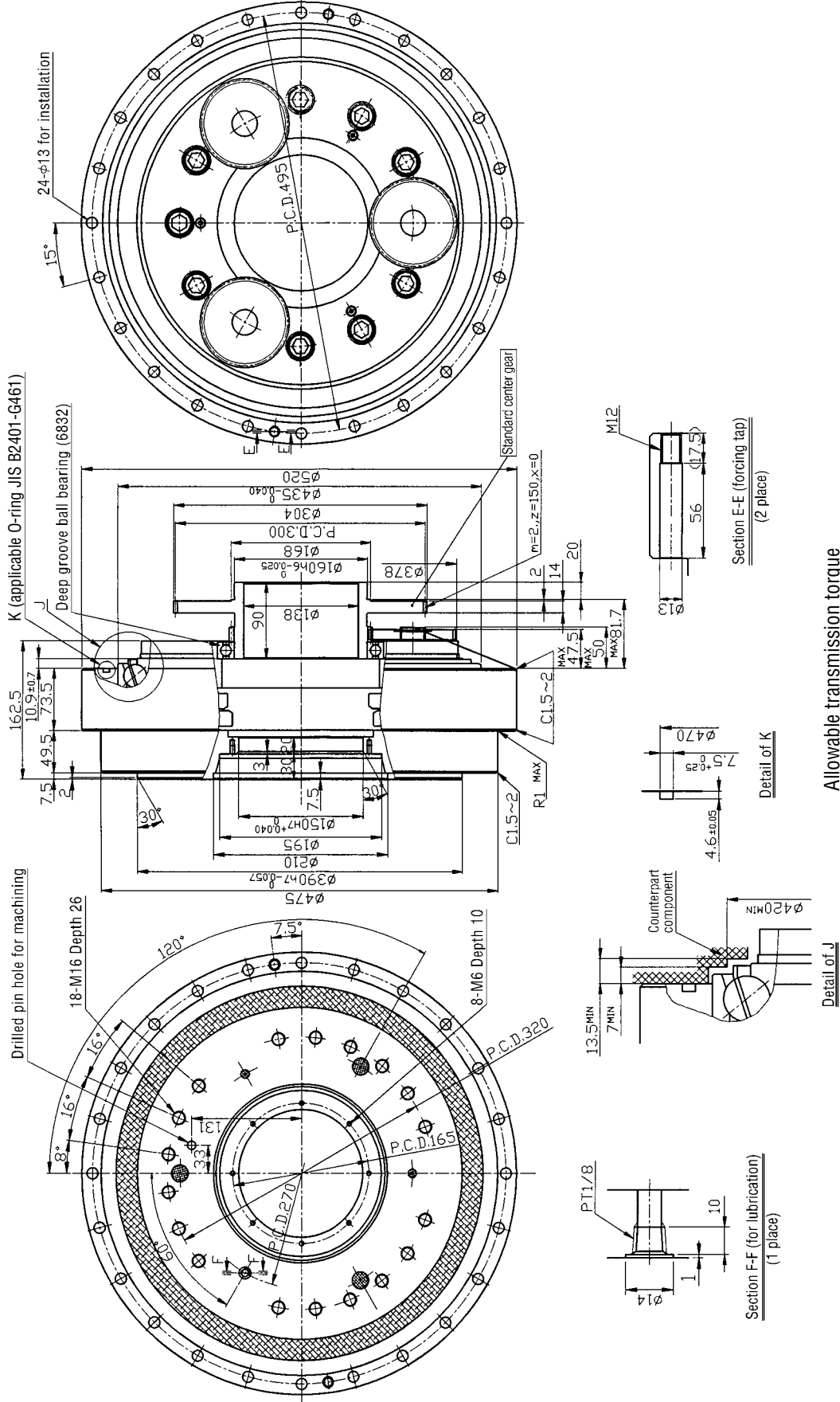

Allowable transmission torque

Number of bolts & Size	Allowable transmission torque
Case side 24-M12	49,088.2Nm
Shaft side 18-M16	44,668.4Nm

Notes 1. Use commercial goods to supply items such as O-rings, mounting bolts and seal washers.
2. Specifications and dimensions are subject to change without notice.

8-8 RV-10C External dimensions of through-bolt clamping output shaft type

Speed ratio

Type code RV-10C-27-A-T

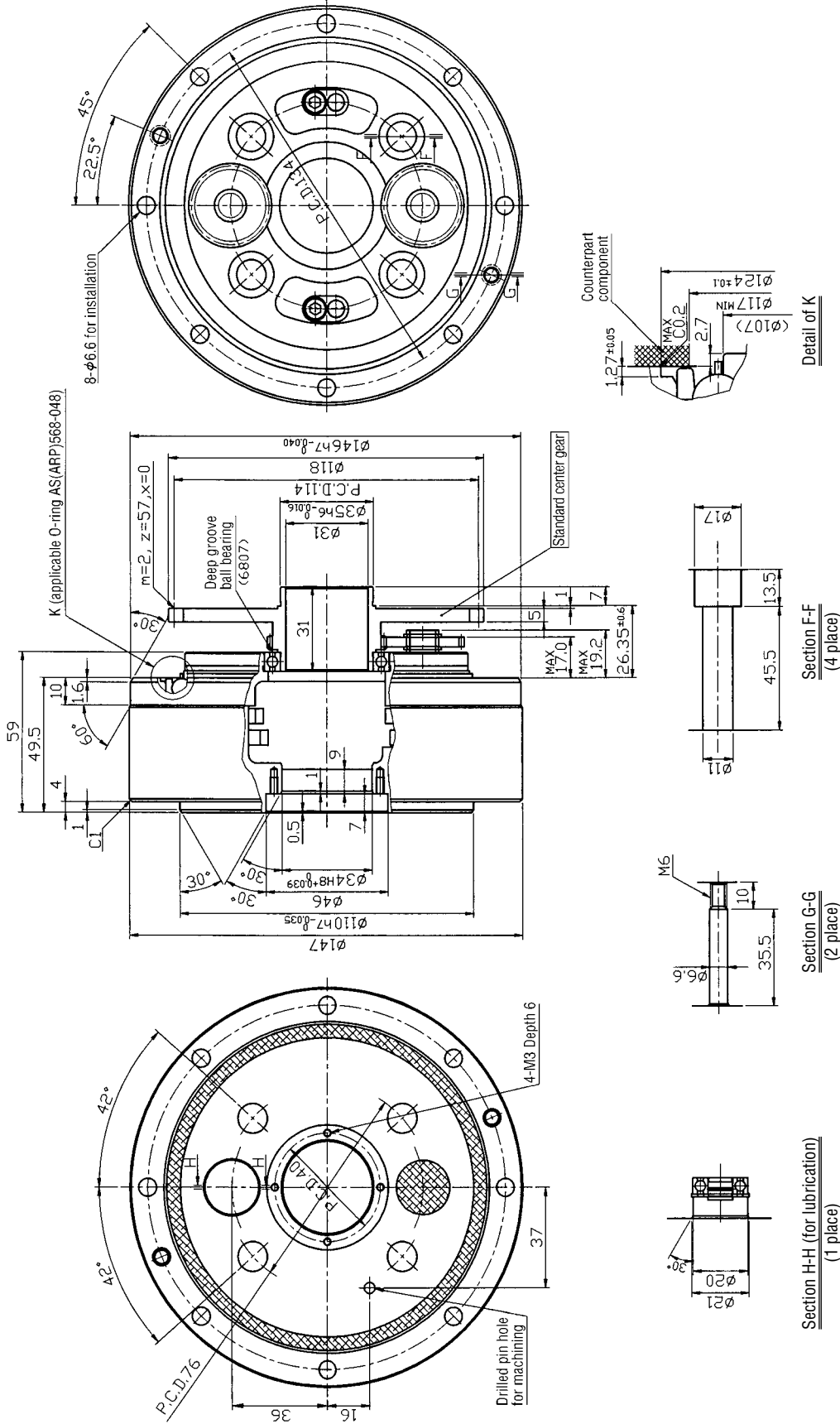

Allowable transmission torque

Number of bolts & size	Allowable transmission torque
8-M6	1,058.4Nm
4-M10	862.4Nm

- Notes 1. Use commercial goods to supply items such as O-rings, mounting bolts and seal washers.
 2. Specifications and dimensions are subject to change without notice.

8-9 RV-27C External dimensions of through-bolt clamping output shaft type

Speed ratio
 Type code RV-27C-36, 57-A-T

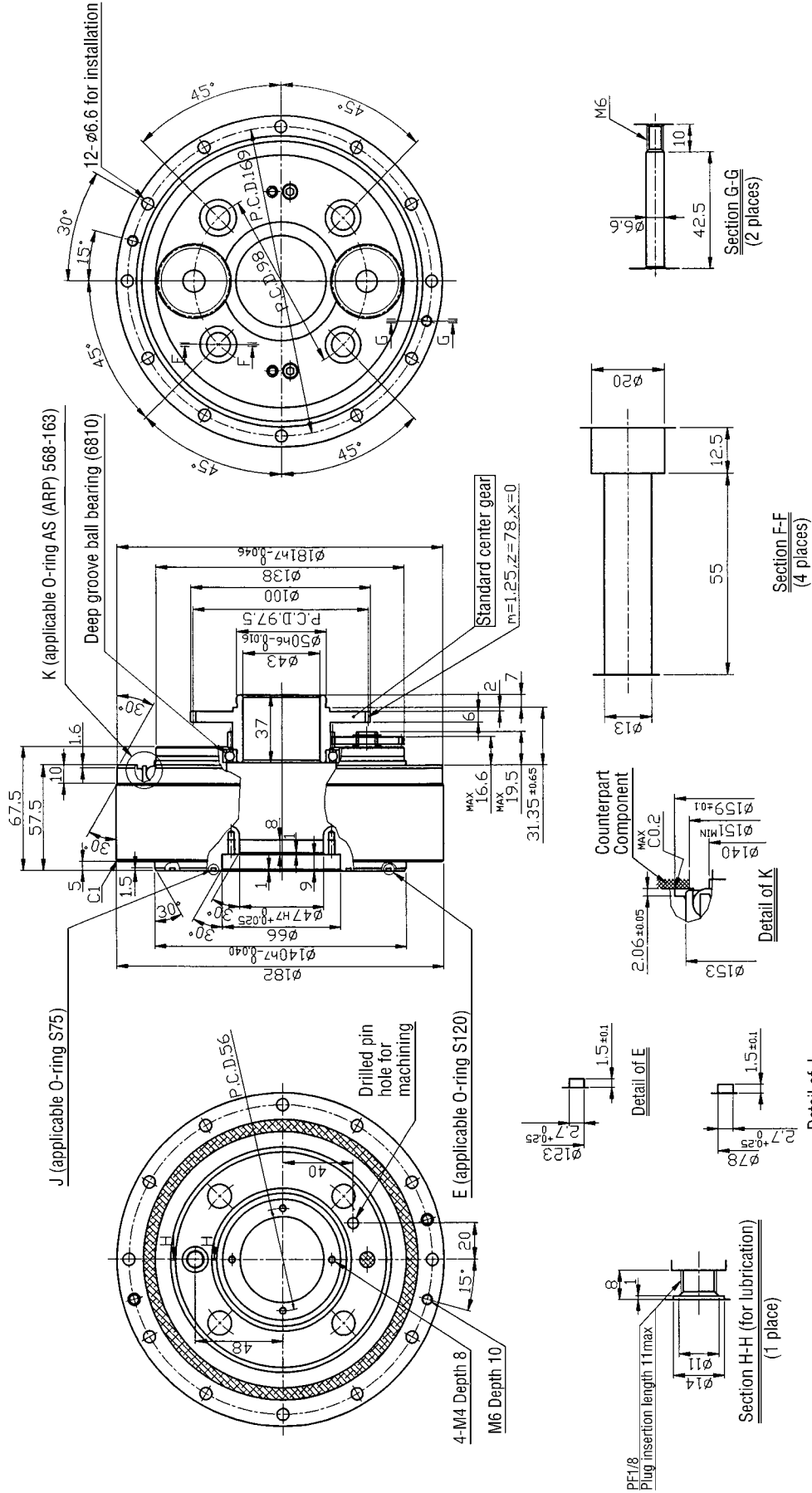

Allowable transmission torque

	Number of bolts & size	Allowable transmission torque
Case side	12-M6	1,999.2Nm
Shaft side	4-M12	1,617Nm

Notes 1. Use commercial goods to supply items such as O-rings, mounting bolts and seal washers.
 2. Specifications and dimensions are subject to change without notice.

8-10 RV-50C External dimensions of through-bolt clamping output shaft type

Speed ratio

32, 54 - **A** - T

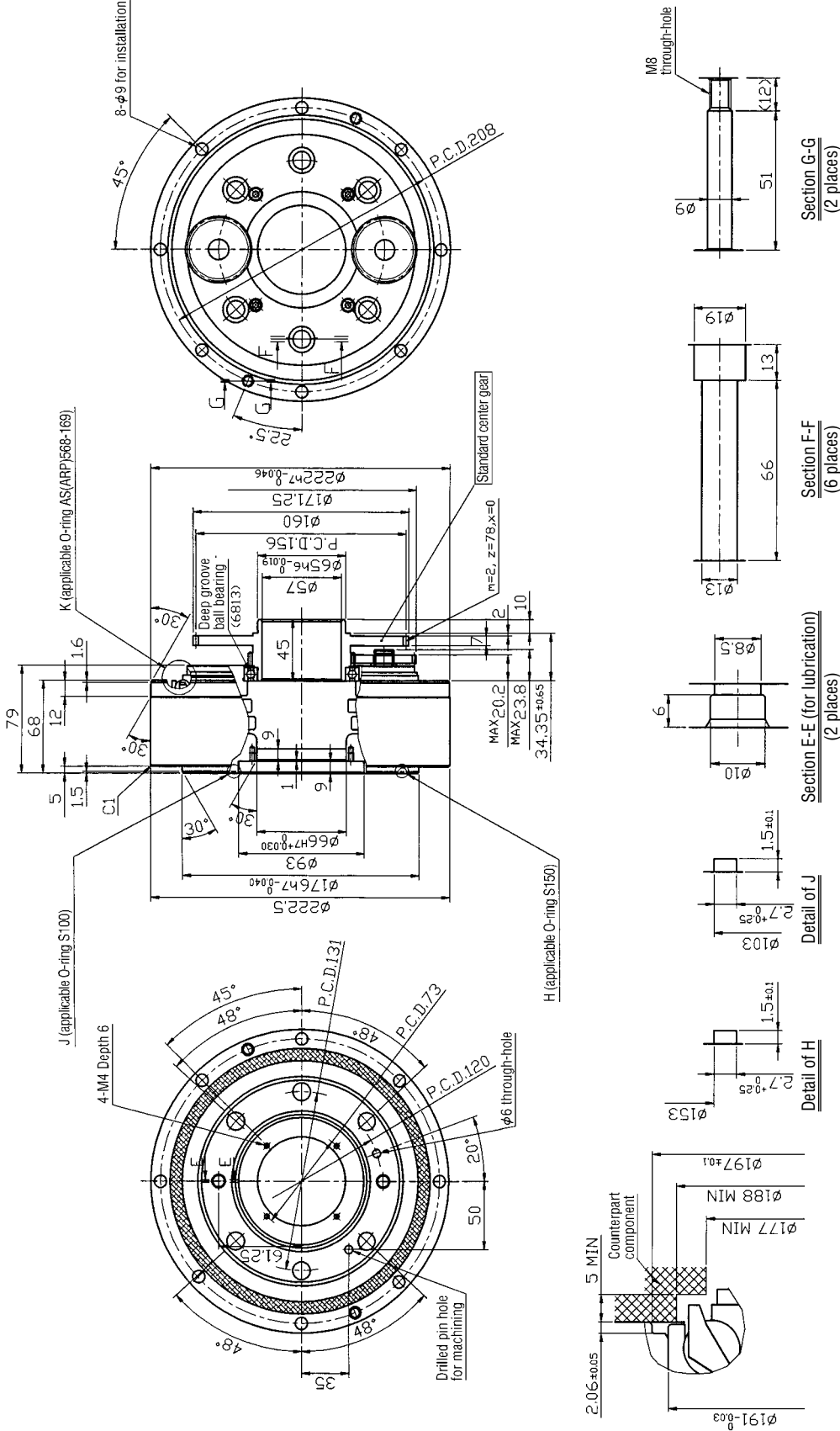

Allowable transmission torque

Number of bolts & size	Allowable transmission torque
Case side 8-M8	2,989Nm
Shaft side 6-M12	3,243.8Nm

- Notes 1. Use commercial goods to supply items such as O-rings, mounting bolts and seal washers.
- 2. Specifications and dimensions are subject to change without notice.

8-11 RV-100C External dimensions of through-bolt clamping output shaft type Type code RV-100C-36,75-A-T

Speed ratio

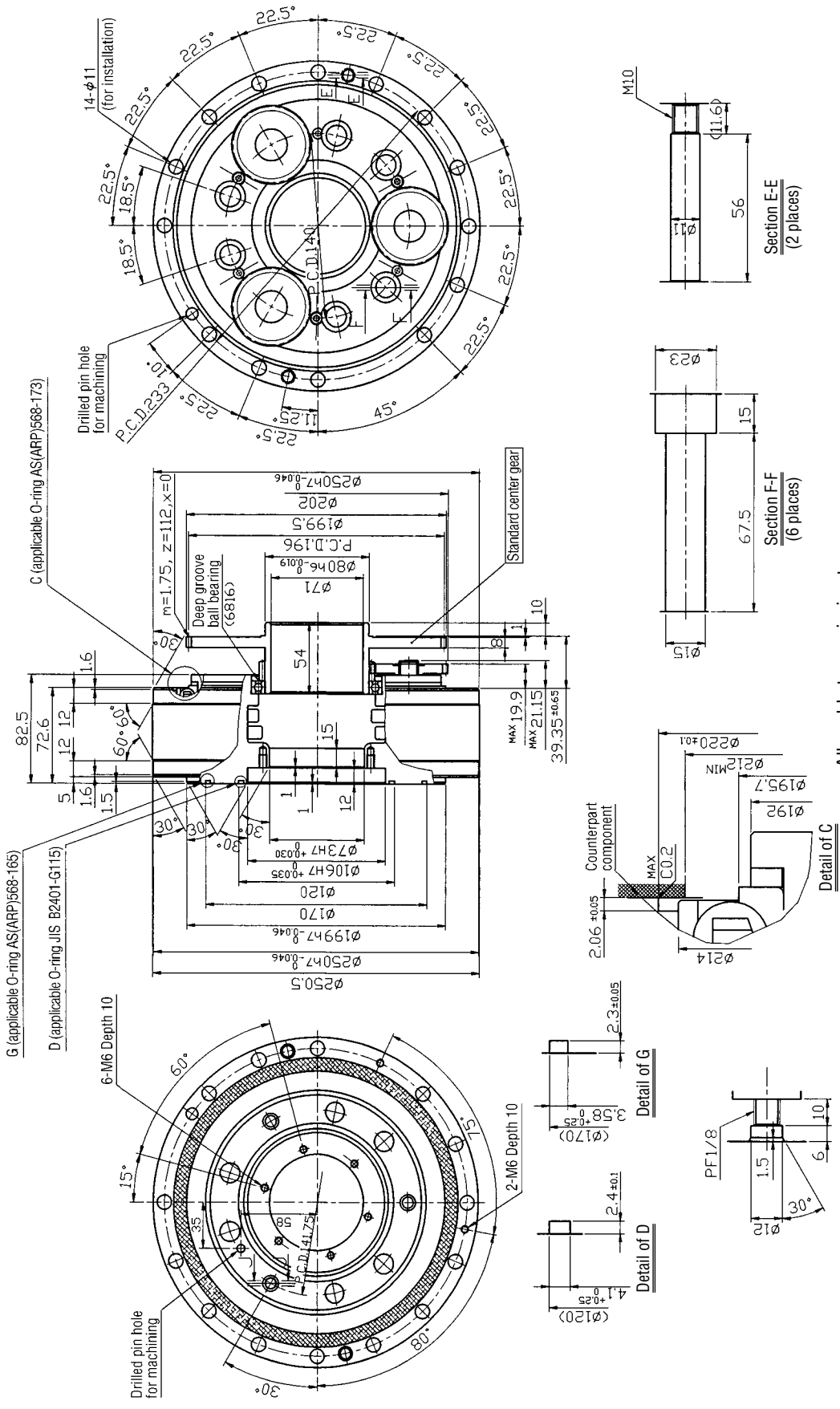

Section J-J (for lubrication) (1 places)

Section F-F (6 places)

Section E-E (2 places)

- Notes 1. Use commercial goods to supply items such as O-rings, mounting bolts and seal washers.
- 2. Specifications and dimensions are subject to change without notice.

8-12 RV-200C External dimensions of through-bolt clamping output shaft type Type code RV-200C-34, 86-1A-T

Speed ratio

34, 86 - 1A-T

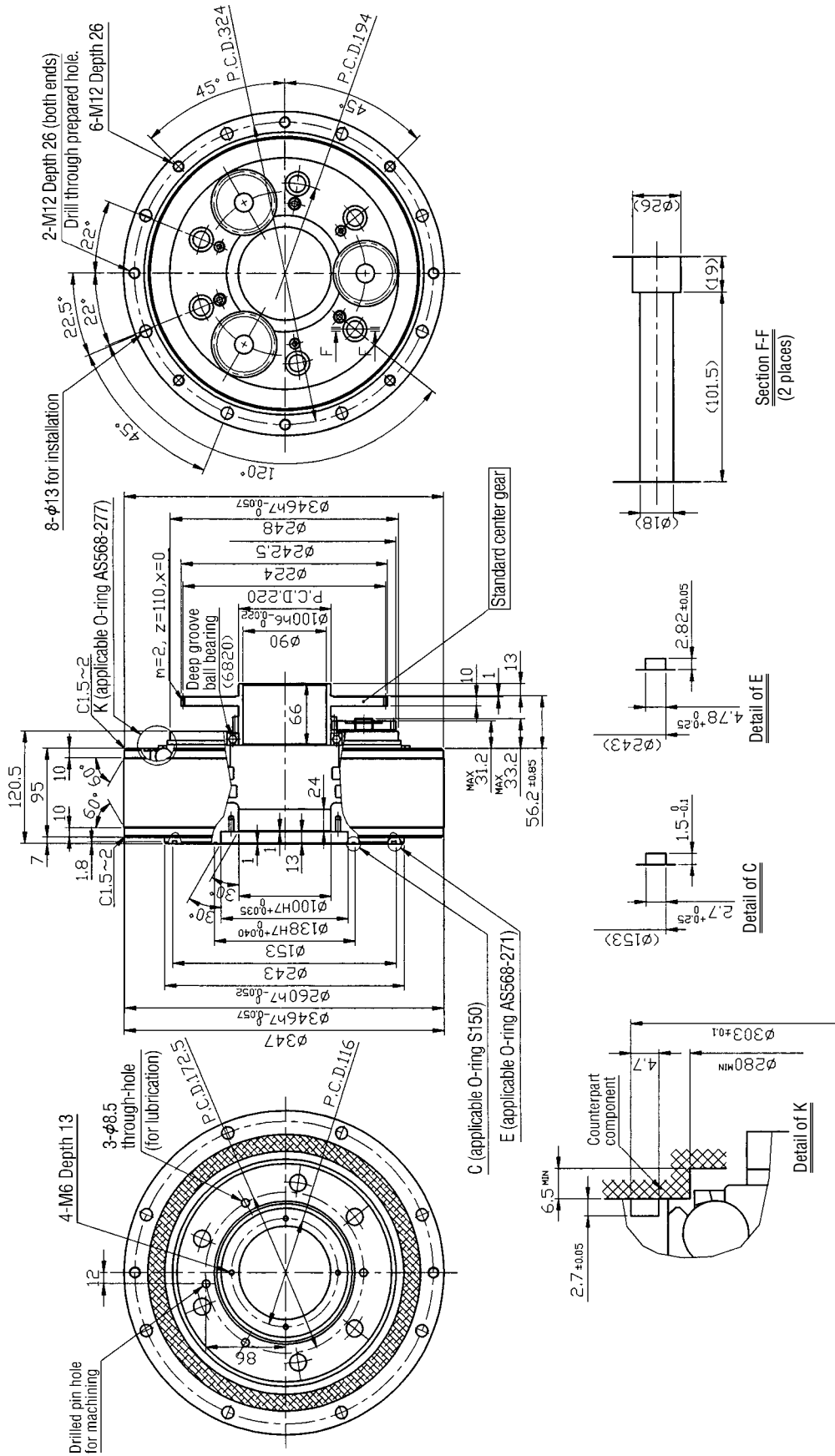

Allowable transmission torque

Number of bolts & size	Allowable transmission torque
Case side 8-M12	10,701.6Nm
Shaft side 6-M16	9,025.8Nm

Notes 1. Use commercial goods to supply items such as O-rings, mounting bolts and seal washers.
2. Specifications and dimensions are subject to change without notice.

8-13 RV-320C External dimensions of through-bolt clamping output shaft type Type code RV-320C-35, 61-A-T

Speed ratio

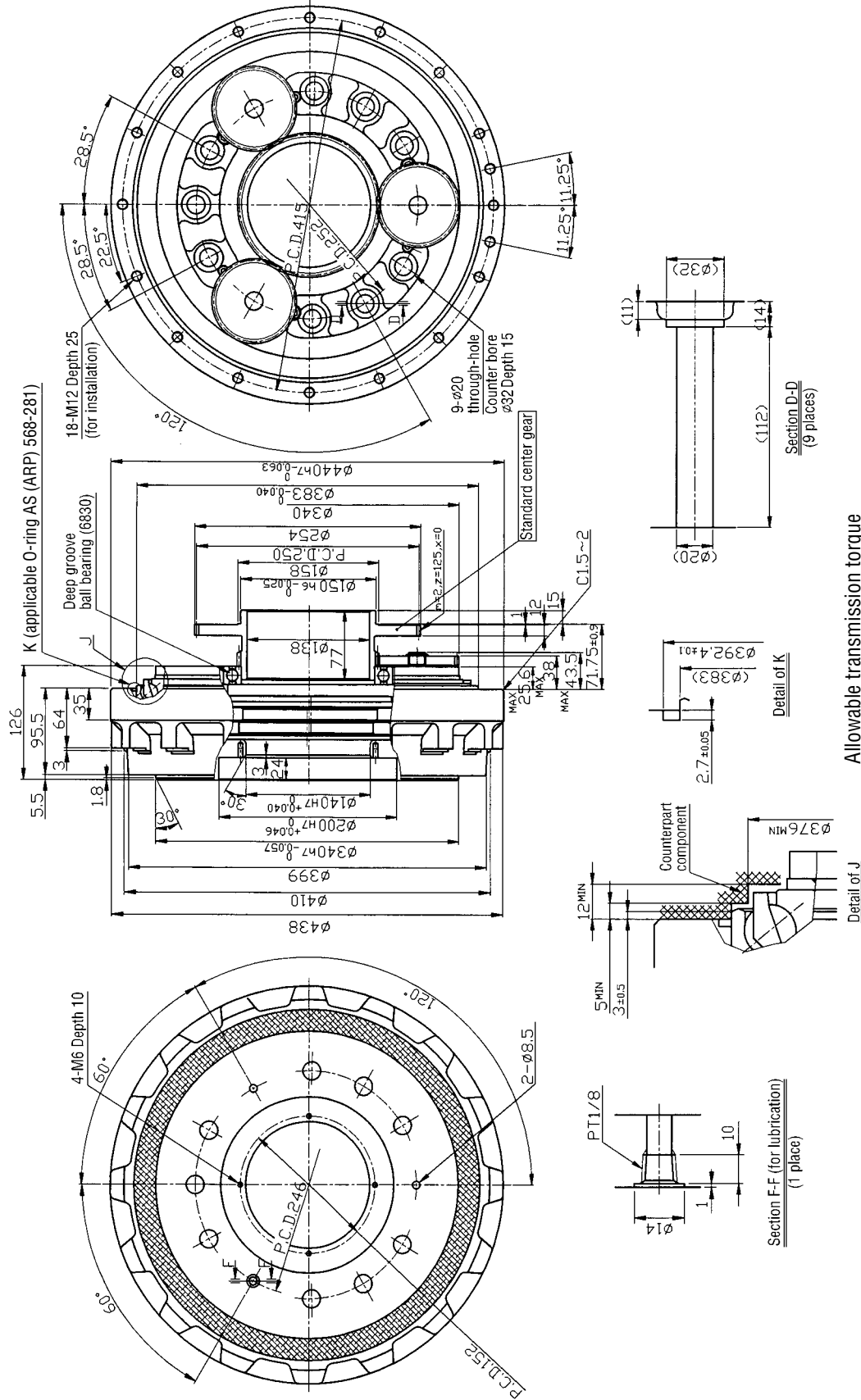

Allowable transmission torque

Number of bolts & Size	Allowable transmission torque
Case side 18-M12	30,870Nm
Shaft side 9-M18	21,560Nm

Notes 1. Use commercial goods to supply items such as O-rings, mounting bolts and seal washers.
2. Specifications and dimensions are subject to change without notice.

RV

series

1 CONSTRUCTION

The construction of the RV reduction gear is shown below.

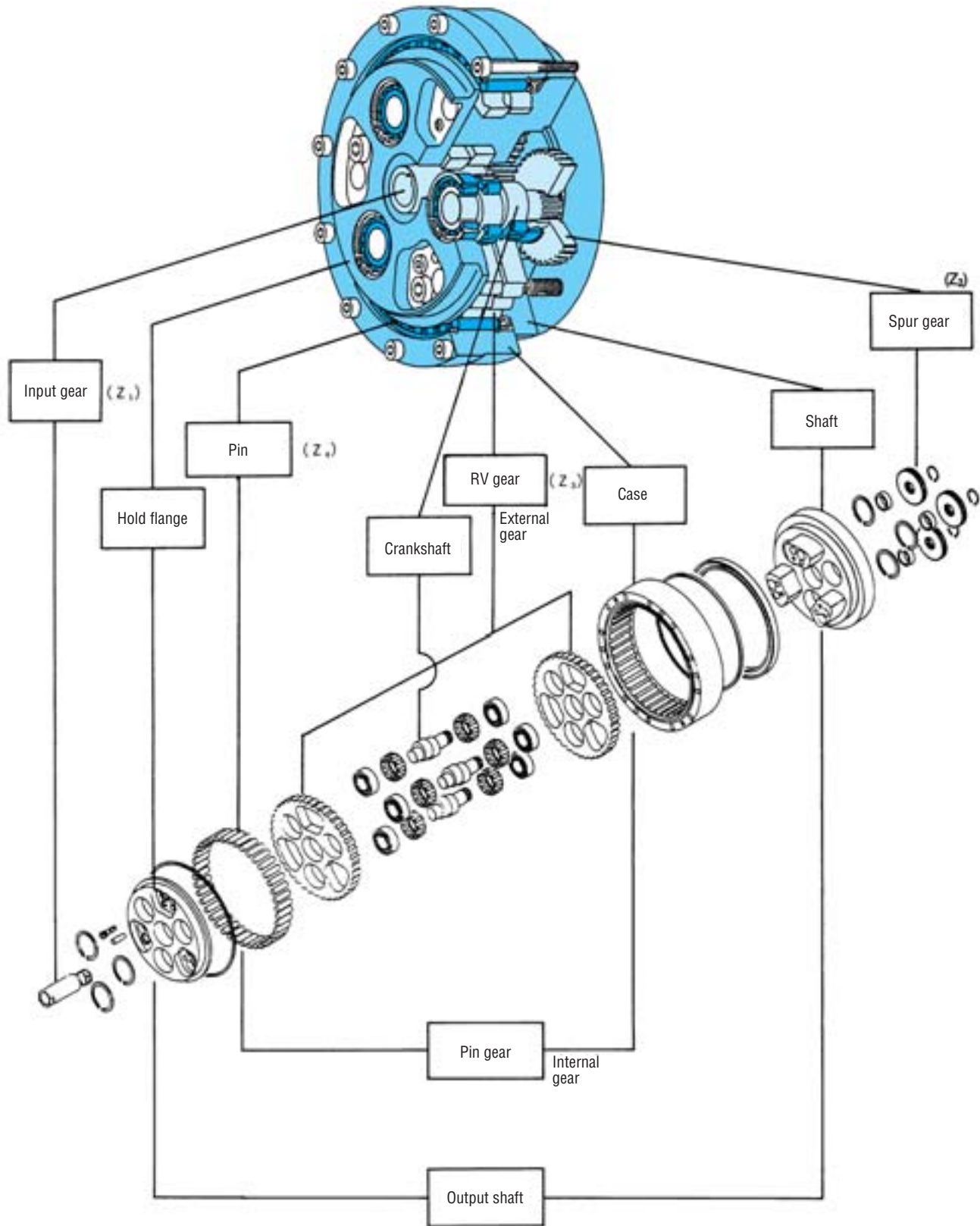

2 ROTARY DIRECTION and SPEED RATIO

The RV reduction gear may be used in various ways. The following figures show six combinations of the rotary direction and speed ratio. Use the following figure to select a mechanism most suitable for your application.

Fig.1

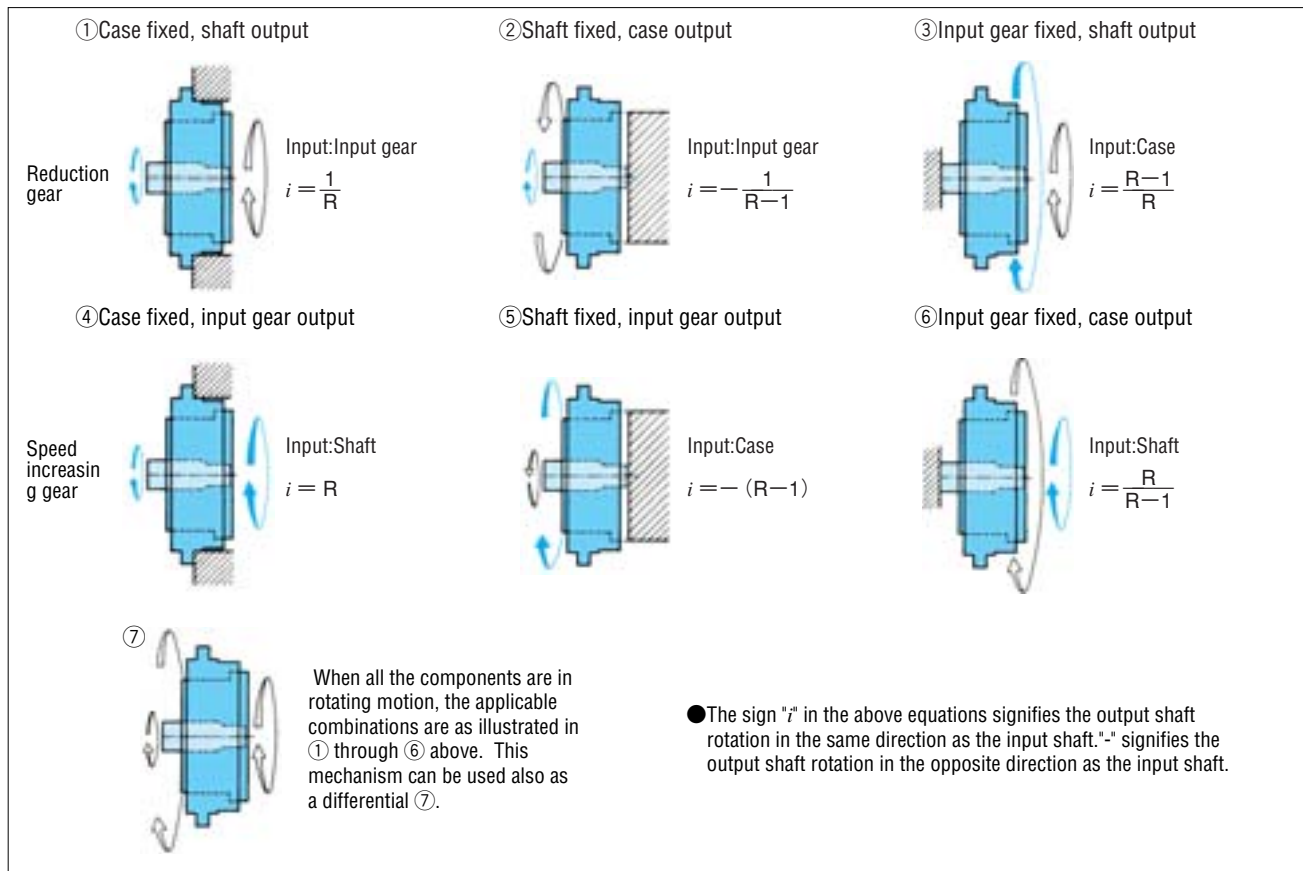

Mechanism block diagram

Fig.2

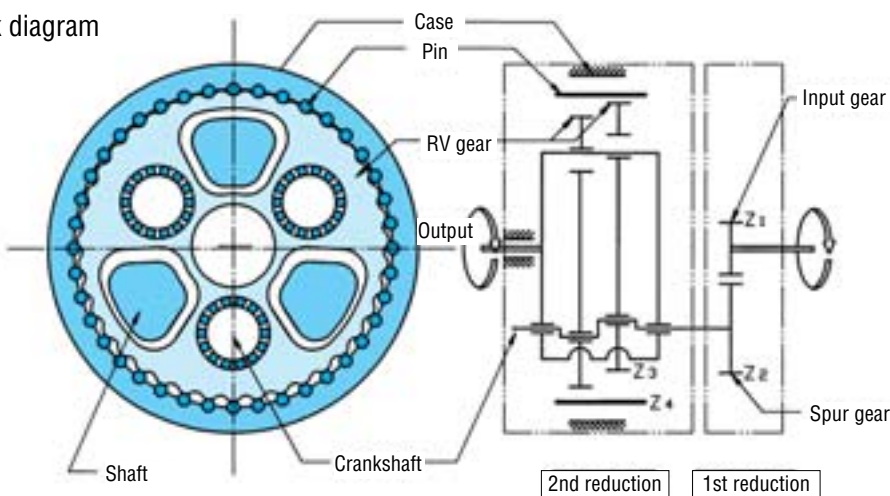

Speed Ratio

The overall ratio can be determined from the following equation:

With the shaft as output; $R = 1 + \frac{Z_2}{Z_1} \cdot Z_4$

$$i = \frac{1}{R}$$

- R : Speed ratio
- Z₁ : Number of teeth on input gear
- Z₂ : Number of teeth on spur gear
- Z₃ : Number of teeth on RV gear
- Z₄ : Number of pins
- i : Reduction ratio

3 RATING TABLE

Table 1

Output speed (r/min)			5		10		15		20		25		30	
Model	Speed ratio		Output torque	Input capacity	Output torque	Input capacity	Output torque	Input capacity	Output torque	Input capacity	Output torque	Input capacity	Output torque	Input capacity
	Shaft rotation	Case rotation	In-lb (Nm)	kW	In-lb (Nm)	kW	In-lb (Nm)	kW	In-lb (Nm)	kW	In-lb (Nm)	kW	In-lb (Nm)	kW
RV-15	57	56	1,692 (191)	0.13	1,373 (155)	0.22	1,213 (137)	0.29	1,107 (125)	0.35	1,045 (118)	0.41	992 (112)	0.49
	81	80												
	105	104												
	121	120												
	141	140												
RV-30	57	56	4,109 (464)	0.32	3,330 (376)	0.53	2,949 (333)	0.70	2,710 (306)	0.85	2,533 (286)	1.00	2,391 (270)	1.13
	81	80												
	105	104												
	121	120												
	153	152												
RV-60	57	56	7,847 (886)	0.62	6,368 (719)	1.00	5,642 (637)	1.33	5,172 (584)	1.63	4,845 (547)	1.91	4,579 (517)	2.17
	81	80												
	101	100												
	121	120												
	153	152												
RV-160	81	80	19,272 (2,176)	1.52	15,712 (1,774)	2.48	13,887 (1,568)	3.28	12,762 (1,441)	4.02	11,894 (1,343)	4.69	11,283 (1,274)	5.34
	101	100												
	129	128												
	145	144												
	171	170												
RV-320	81	80	38,624 (4,361)	3.04	31,335 (3,538)	4.94	27,774 (3,136)	6.57	25,516 (2,881)	8.05	23,160 (2,615)	9.41	22,567 (2,548)	10.7
	101	100												
	118.5	117.5												
	129	128												
	141	140												
	171	170												
	185	184												
RV-450	81	80	54,335 (6,135)	4.28	44,088 (4,978)	6.95	39,058 (4,410)	9.24	35,843 (4,047)	11.3	33,505 (3,783)	13.2		
	101	100												
	118.5	117.5												
	129	128												
	*154.8	153.8												
	171	170												
	*192.4	191.4												
RV-550	123	122	66,398 (7497)	5.23	53,901 (6086)	8.50	47,737 (5390)	11.29	43,831 (4949)	13.82				
	141	140												
	163.5	162.5												
	*192.4	191.4												

Notes: 1. Set maximum input shaft revolutions to a value equal to or lower than the value of maximum allowable output revolutions multiplied by the above speed ratio for each type.

2. The input capacity (kW) in the above table is determined by the efficiency of these reduction gears.

3. The output torque (In-lb) is so determined that the service life may be maintained constant for any output revolutions. ($N \cdot T^{\frac{10}{3}} = \text{Constant}$)

4. The rated torque is a torque at an output speed of 15 r/min, which is used as a basis for service life calculations. (Refer to the rated service life, page 97).

5. The $\frac{GD^2}{4}$ value is a value considering both gear tooth widths of reduction gear assembly and input gear. The $\frac{GD^2}{4}$ value at the shaft of the input gear is not included.

40		50		60		Allowable max. output speed (Continuous) r/min	Allowable acceleration deceleration torque In-lb (Nm)	Momentary max. allowable torque (E-stop) In-lb (Nm)	Lost motion arc.min.	Torsional rigidity (Stiffness) (Typical Value) In-lb/arc.min. (Nm/arc.min.)	I(= $\frac{GD^2}{4}$) (Input inertia)		Weight lb (kg)
Output torque In-lb (Nm)	Input capacity kW	Output torque In-lb (Nm)	Input capacity kW	Output torque In-lb (Nm)	Input capacity kW						Tooth width mm	kg-m ²	
903 (102)	0.57	850 (96)	0.67	806 (91)	0.76	60	2,427 (274)	6,076 (686)	1	347 (39.2)	8	0.075×10 ⁻⁴	7.7 (3.5)
												0.0488×10 ⁻⁴	
												0.0355×10 ⁻⁴	
												0.0295×10 ⁻⁴	
												0.0241×10 ⁻⁴	
2,196 (248)	1.39	2,055 (232)	1.62			50	7,378 (833)	14,755 (1,666)	1	868 (98)	10	0.2323×10 ⁻⁴	14.3 (6.5)
												0.168×10 ⁻⁴	
												0.128×10 ⁻⁴	
												0.109×10 ⁻⁴	
												0.0823×10 ⁻⁴	
4,198 (474)	2.65					40	14,104 (1,592.5)	28,208 (3,185)	1	1,736 (196)	10	0.7312×10 ⁻⁴	22 (10.0)
												0.513×10 ⁻⁴	
												0.404×10 ⁻⁴	
												0.328×10 ⁻⁴	
												0.245×10 ⁻⁴	
						45	34,718 (3,920)	58,586 (6,615)	1	3,472 (392)	15	1.963×10 ⁻⁴	44.1 (20.0)
												1.505×10 ⁻⁴	
												1.105×10 ⁻⁴	
												0.903×10 ⁻⁴	
												0.755×10 ⁻⁴	
						35	69,436 (7,840)	108,493 (12,250)	1	8,679 (980)	16	0.523×10 ⁻³	80.5 (36.5)
												0.400×10 ⁻³	
												0.328×10 ⁻³	
												0.295×10 ⁻³	
												0.263×10 ⁻³	
												2.005×10 ⁻⁴	
												1.793×10 ⁻⁴	
						25	97,644 (11,025)	164,910 (18,620)	1	10,415 (1,176)	18	0.893×10 ⁻³	110.2 (50.0)
												0.695×10 ⁻³	
												0.575×10 ⁻³	
												0.518×10 ⁻³	
												0.408×10 ⁻³	
												0.358×10 ⁻³	
						20	119,343 (13,475)	238,685 (26,950)	1	14,755 (1,666)	22	1.178×10 ⁻³	156.5 (71)
												0.994×10 ⁻³	
												0.820×10 ⁻³	
												0.655×10 ⁻³	

6. If a higher speed than the above allowable maximum output speed is required, contact Nabtesco for further information.
7. If other speed ratio than the above list is required, contact Nabtesco for further information.
8. These reduction gear ratios are indivisible figures. Actually, 154.8=2,013/13 and 192.4=1,347/7.
9. The output revolution is for forward-reverse changeover applications and not applicable for continuous rotation in a single direction. Contact Nabtesco when using the reduction gear for continuous single-direction rotation.

4-1 Selection flow chart

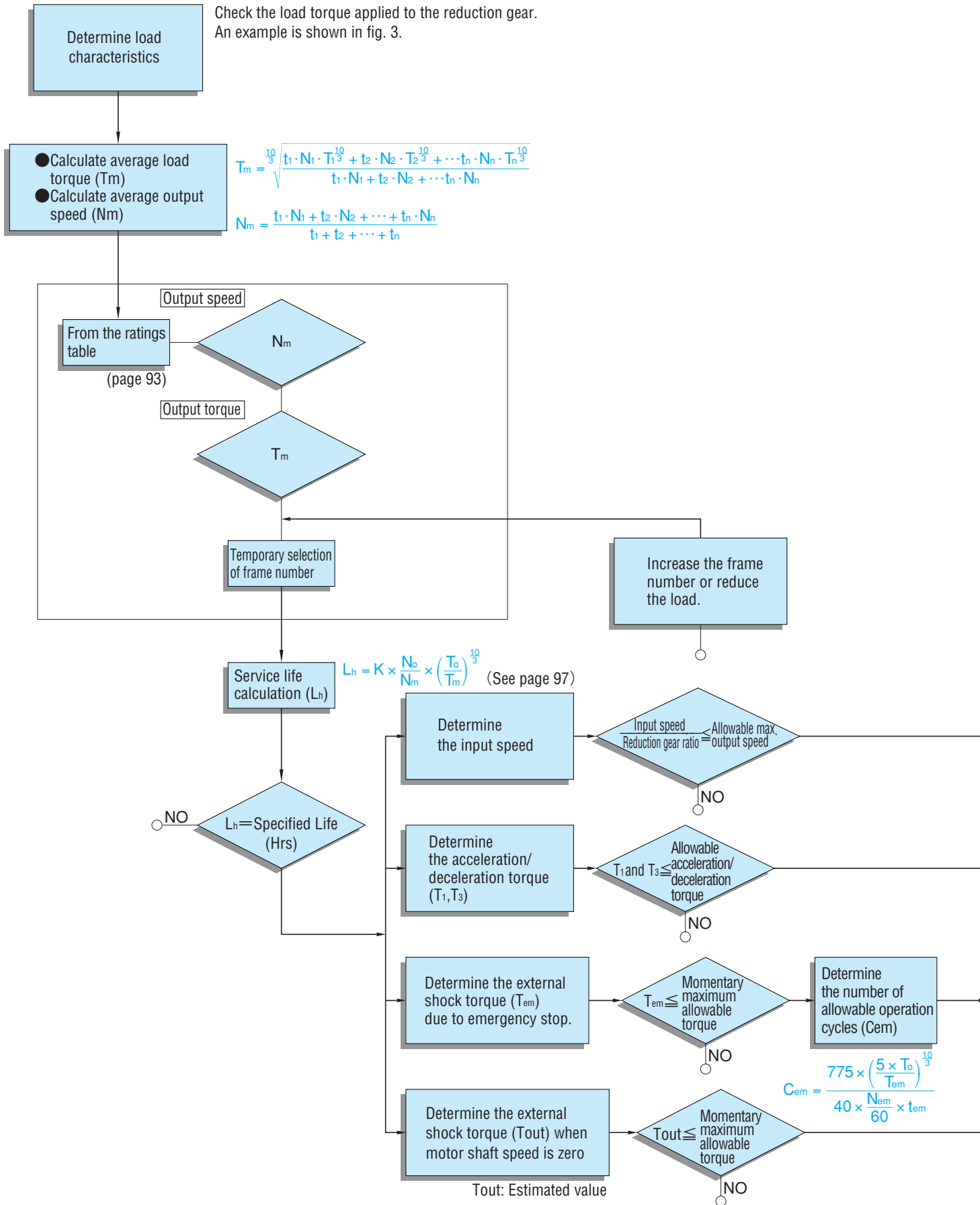

Selection example

Selection conditions

$$T_1=22,125\text{In-lb} \quad T_2=4,425\text{In-lb}$$

$$T_3=13,275\text{In-lb} \quad T_{em}=53,100\text{In-lb}$$

$$t_1=0.2\text{sec.} \quad t_2=0.5\text{sec.}$$

$$t_3=0.2\text{sec.} \quad t_{em}=0.05\text{sec.}$$

$$N_1=N_3=10\text{r/min} \quad N_2=20\text{r/min}$$

$$N_{em}=20\text{r/min}$$

Determine load characteristic

● Determine average load torque

$$T_m = \sqrt[10]{\frac{0.2 \times 10 \times 22,125^{10} + 0.5 \times 20 \times 4,425^{10} + 0.2 \times 10 \times 13,275^{10}}{0.2 \times 10 + 0.5 \times 20 + 0.2 \times 10}}$$

$$= 13,053\text{In-lb}$$

● Determine average output speed

$$N_m = \frac{0.2 \times 10 + 0.5 \times 20 + 0.2 \times 10}{0.2 + 0.5 + 0.2} = 15.6\text{r/min}$$

Provisional selection of RV-160-129.

● Calculation to determine whether reduction gear service life meets required specification value.

$$L = 6,000 \times \frac{15}{15.6} \times \left(\frac{13,887}{13,053}\right)^{10} = 7,092\text{Hr}$$

● Determine output speed

Maximum output speed 20r/min < 45r/min

(Maximum allowable output speed of RV-160)

● Determine torque during starting and stopping

$$T_1 = 22,125\text{In-lb} < 34,718\text{In-lb}$$

(Allowable acc./dec. torque for RV-160)

$$T_2 = 13,275\text{In-lb} < 34,718\text{In-lb}$$

(Allowable acc./dec. torque for RV-160)

● Determine emergency stop and external shock torque

$$T_{em} = 53,100\text{In-lb} < 58,586\text{In-lb}$$

(Momentary max. allowable torque for RV-160)

$$C_{em} = \frac{775 \times \left(\frac{5 \times 13,877}{53,100}\right)^{10}}{40 \times \frac{20}{60} \times 0.05} = 2,835 \text{ times}$$

Since all required specification are satisfied, select RV-160-129.

However, the design of external bearings is to be studied.

Fig.3

Duty cycle diagram

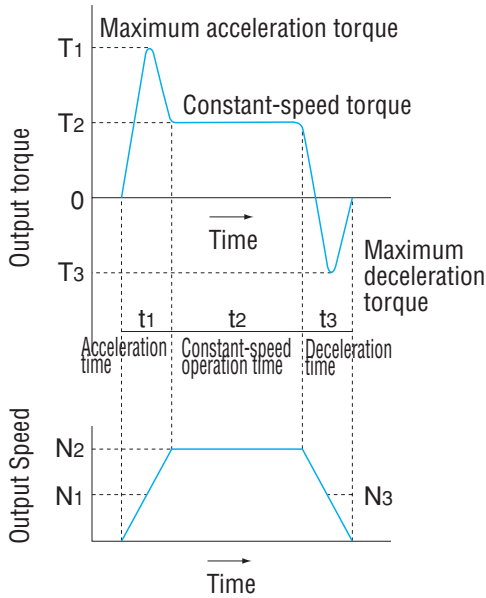
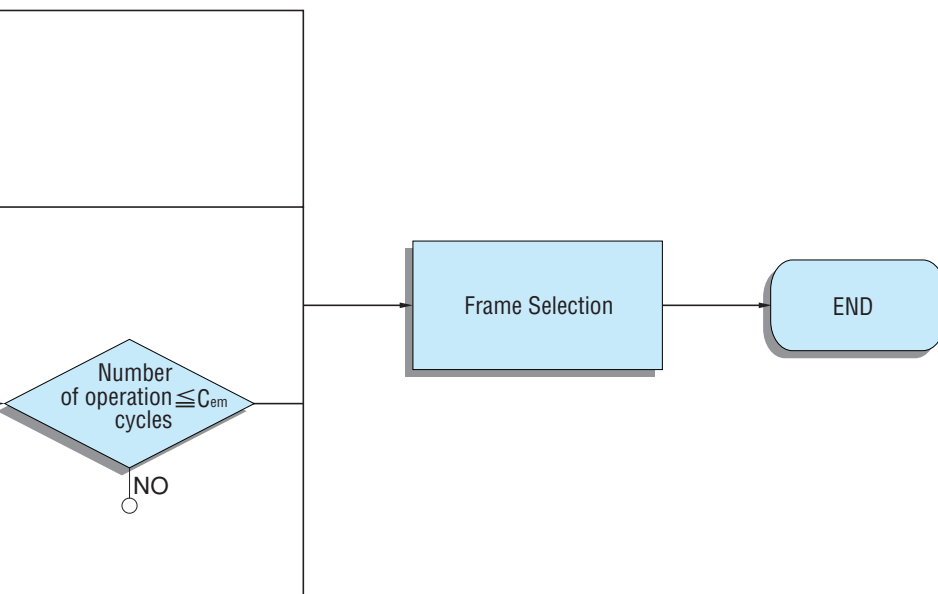

Table 2 Conditions to be determined for selection

	For starting (Max)	For constant	For stopping (Max)	For impact due to emergency stop
Load torque In-lb	T ₁	T ₂	T ₃	T _{em}
Speed r / min	N ₁	N ₂	N ₃	N _{em}
Time sec	t ₁	t ₂	t ₃	t _{em}



4-2 Strength and service life

4-2-1 Allowable torque during acceleration or deceleration

When the Machine starts (or stops) a larger torque than steady-state torque is applied to the reduction gear because of the internal loads. The values in the ratings table (see page 93) show the allowable value of the peak torque when the reduction gear starts or stops.

With the RV-15, the allowable acceleration/deceleration torque is 200% of the rated torque; other models in the series have a acceleration/deceleration torque of 250% of the rated torque.

4-2-2 Momentary maximum allowable torque

A large torque during an emergency stop or external shock may be applied to the reduction gear. The maximum allowable torque is shown in the ratings table(see page 93).

Momentary maximum allowable torque is 500% of the rated torque.

Note)When shock torque is applied, be sure to use at or bellow the limit cycles (refer to selection flowchart on page 95).

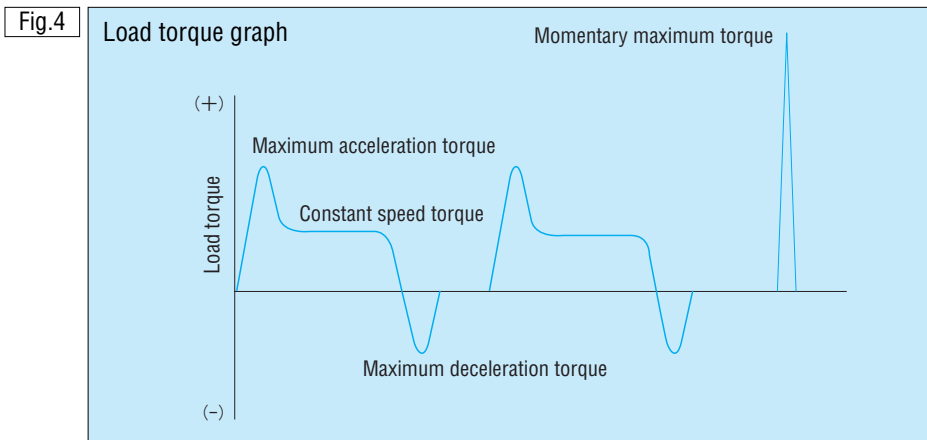

4-2-3 Rated service life

The service life of the RV reduction gear is based on the life of the roller bearings of the crankshafts. The service life is set as shown in Table 3 for all models and ratios at rated torque and at rated output speed.

L_h	Service life (Hrs)	
L_{10}	K	6,000

When in actual service installed in the equipment, calculate the service life using the following formula because the load condition depends on the types of reduction gear.

$$L_h = K \times \frac{N_o}{N_m} \times \left(\frac{T_o}{T_m} \right)^{\frac{10}{3}}$$

L_h : Service life to be obtained (Hr)
 N_m : Average output speed (r/min) (calculation on page 93)
 T_m : Average output torque (In-lb) (calculation on page 93)
 N_o : Rated output speed (r/min) (table 4)
 T_o : Rated output torque (In-lb) (table 4)

Type	Rated output torque (T_o) In-lb(Nm)	Rated output speed (N_o)r/min
RV-15	1,213 (137)	15
RV-30	2,949 (333)	
RV-60	5,642 (637)	
RV-160	13,887 (1,568)	
RV-320	27,774 (3,136)	
RV-450	39,058 (4,410)	
RV-550	47,737 (5,390)	

5 PERFORMANCE CHARACTERISTICS

5-1 Rigidity (Torsional rigidity and lost motion) and backlash

When a torque is applied to the output shaft while the input shaft (input gear) is fixed, torsion is generated according to the torque value and a hysteresis curve result is shown in Fig. 5.

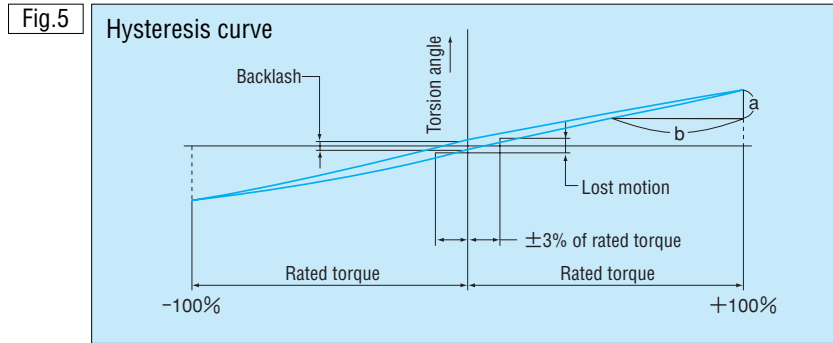

The rigidity of the reduction gear is expressed by the torsional rigidity and the lost motion in this curve. RV reduction gears are especially superior in their stiffness characteristics.

- Torsional rigidity = $\frac{b}{a}$

- Lost motion

The torsion angle at the mid point of the hysteresis curve width at $\pm 3\%$ of rated torque.

- Backlash

The torsion angles when the torque indicated by the hysteresis curve is zero.

5-1-1 Calculation of torsion (an example)

Take an example of the RV-160 and find a torsion where a torque is applied in one direction.

1) If a torque of 265.5In-lb is applied, the resulting torsion ST_1 , is found as shown below.

- Note that the torque is in the lost motion range.

$$ST_1 = \frac{265.5}{416.3} \times \frac{1(\text{arc.min.})}{2} = 0.32\text{arc.min.}$$

2) If a torque of 11,505In-lb is applied, the resulting torsion ST_2 is found as shown below.

- Note that the torque is in the rated torque range.

$$ST_2 = \frac{1}{2} + \frac{11,505 - 416.3}{3,472} = 3.70\text{arc.min.}$$

- Notes) 1. The above torsion value is that of the reduction gear assembly.
2. For special specifications of backlash and lost motion, contact Nabtesco.

Table 5

Model	Torsional rigidity In-lb/arc.min..	Lost motion		Backlash arc.min
		Lost motion arc.min.	Measured torque In-lb	
RV-15	347	MAX1	± 36.5	1
RV-30	868		± 88.6	
RV-60	1,736		± 169.2	
RV-160	3,472		± 416.3	
RV-320	8,679		± 832.5	
RV-450	10,415		± 1,169.1	
RV-550	14,755		± 1,432.1	

5-2 Vibration

The vibration is a torsional vibration in the circumferential direction when driven by a servomotor with an inertia load applied.

The vibration is one of the most important characteristics, especially when precise contouring control is required. For example, the industrial robot requires exact and smooth contour control for its longer arm.

An actual measured example of the vibration characteristics is shown in Fig. 6.

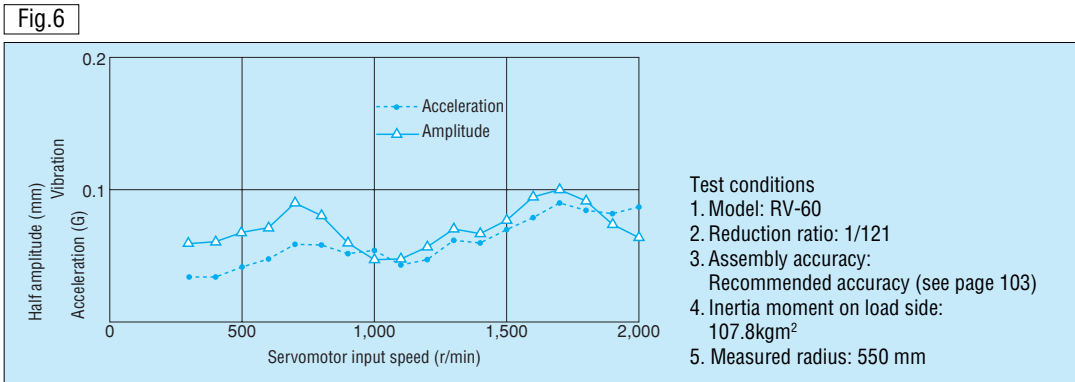

5-3 Angular transmission accuracy

Angular transmission accuracy refers to a difference between the theoretical output revolution angle and the actual revolution angle (θ out) when any revolution angle (θ in) is the input, and is expressed as an angular transmission error (θ er). The angular transmission error is found in the following equation.

$$\theta \text{ er} = \frac{\theta \text{ in}}{R} - \theta \text{ out} \quad (\text{where } R = \text{reduction ratio})$$

The measured example is shown below.

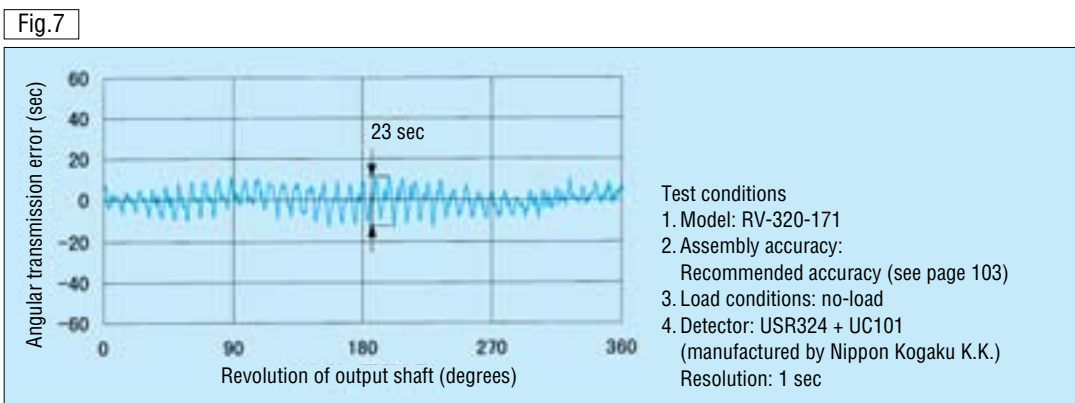

5-4 No-load running torque

The no-load running torque means a torque required on the input shaft (input gear) side in order to rotate the RV reduction gear under no load. Fig. 8 shows the no-load running torque on the output shaft side, which is converted from the no-load running torque according to the following equation.

● No-load running torque converted to motor shaft (In-lb)

$$= \frac{\text{converted torque on the output shaft side(In-lb)}}{R} \quad (\text{where } R = \text{speed ratio})$$

Note: The diagram below shows average values obtained after a RV reduction gear has been run.

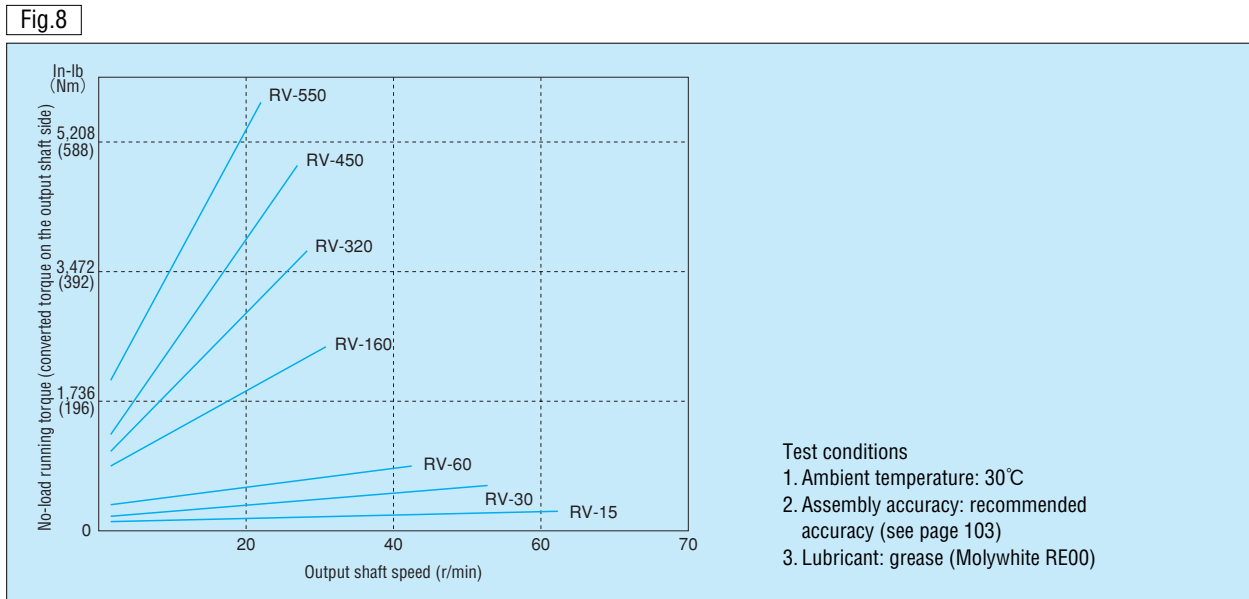

5-5 Backdriving torque

The backdriving torque refers to a torque required for starting the output shaft, with the RV reduction gear left under no-load. If the input shaft (input gear) is released while a torque equal to or more than the backdriving torque is kept applied to the output shaft, the input shaft (input gear) starts running at an augmented speed. Special care should be given to the backdriving torque required to start the RV reduction gear.

Table 6

Model	Backdriving torque In-lb(Nm)
RV-15	186 (21)
RV-30	337 (38)
RV-60	611 (69)
RV-160	974 (110)
RV-320	1,860 (210)
RV-450	2,303 (260)
RV-550	2,923 (330)

Test conditions
 Assembly accuracy: recommended accuracy
 (see page 103)
 Lubricant: grease (Molywhite RE00)

5-6 Low-temperature Characteristics (No-load running torque under low temperature)

Test conditions

1. Assembly accuracy: recommended accuracy (see page 103)
2. Lubricant: grease (Molywhite RE00)
3. Input speed: 2,000 r/min

When the RV reduction gear is used under a low temperature, viscosity of lubricant increases and causes a larger no-load running torque.

The no-load running torque under low temperature is shown below.

Fig.9

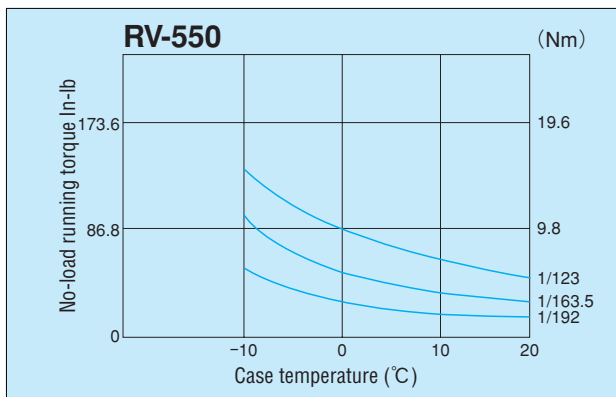
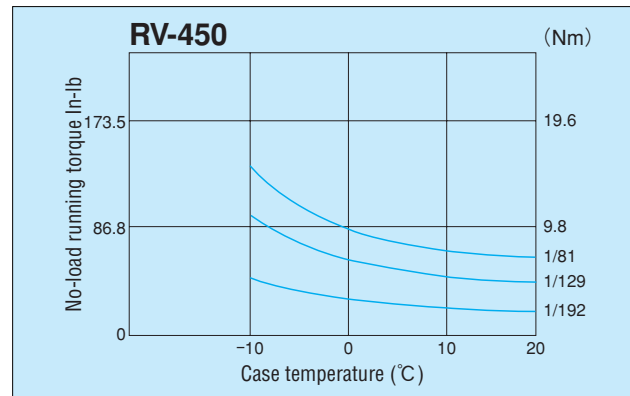
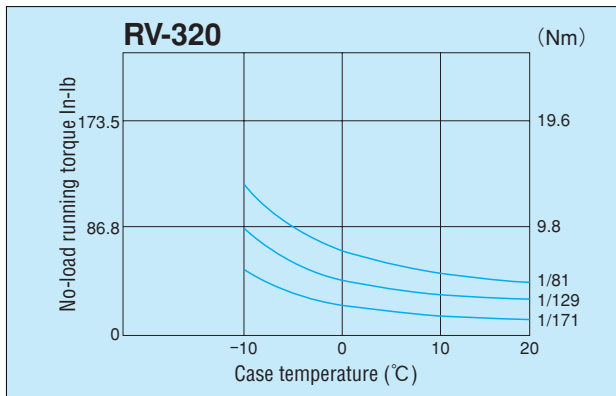
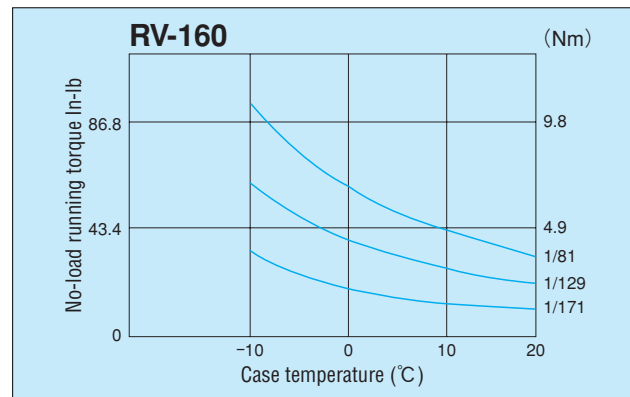
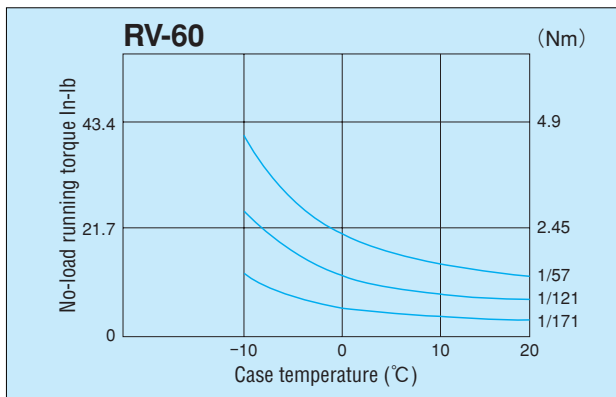
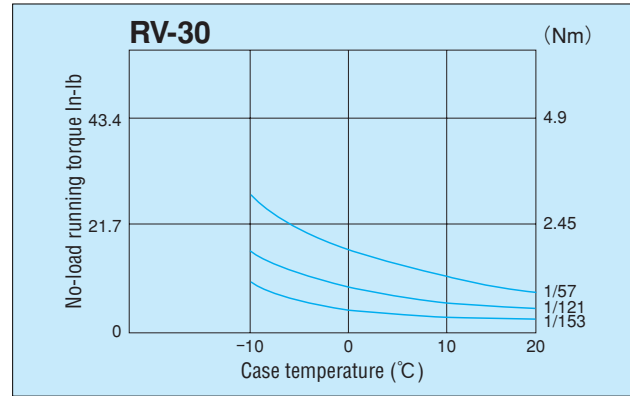
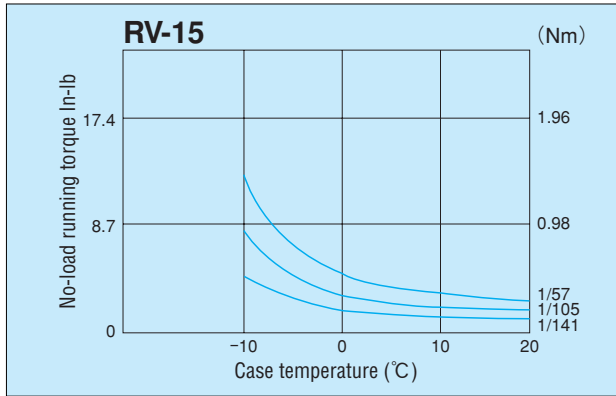

5-7 Efficiency charts

Test conditions

1. Case temperature: 30°C
2. Assembly accuracy: recommended accuracy (see page 103)
3. Lubricant: grease (Molywhite RE00)

Fig.10

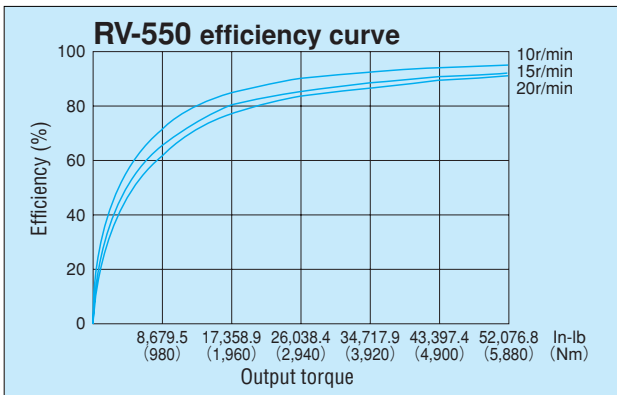
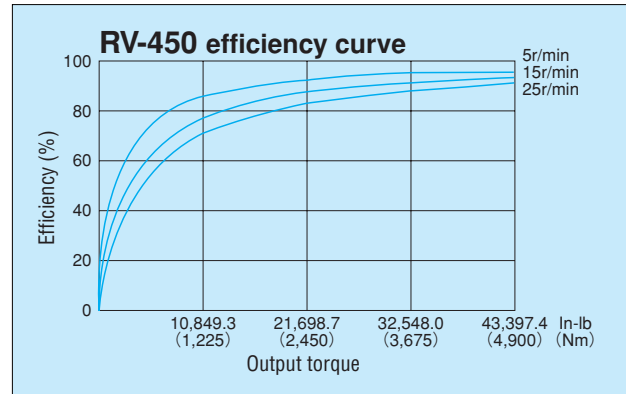
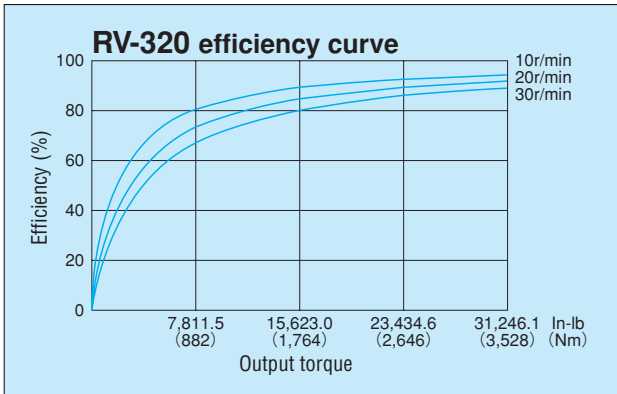
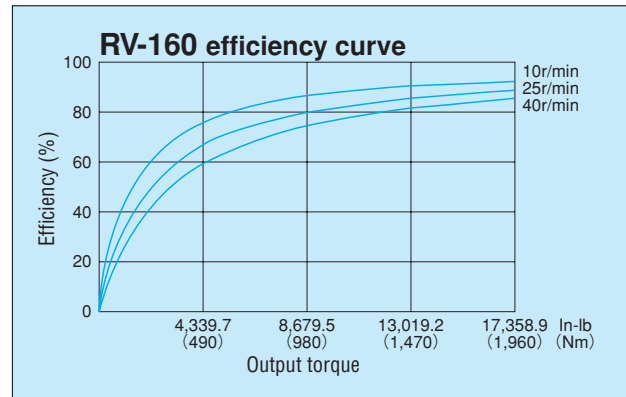
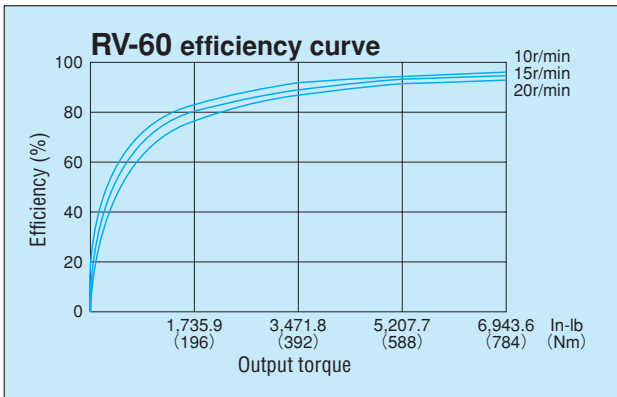
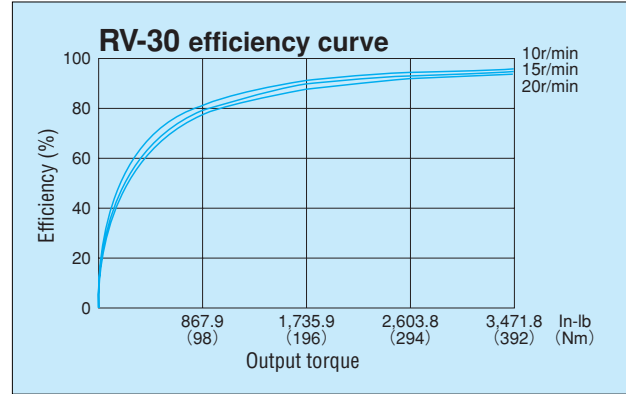
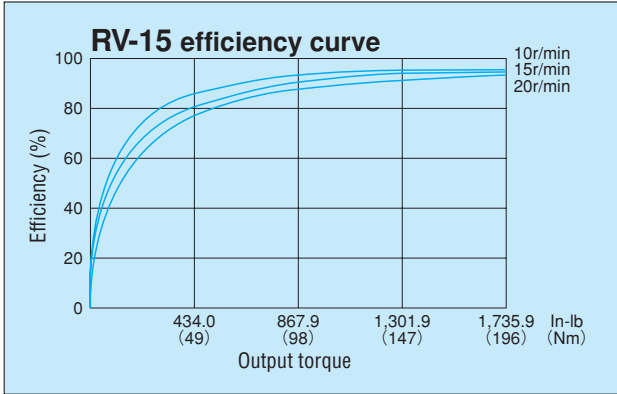

6 INSTALLATION AND ASSEMBLY

Since the RV reduction gear is designed to be an integral part of the equipment, make sure that external thrust or radial loads are not applied to it. When aluminum is used in the structure housing the RV reduction gear, the clamping force for fixing the bolts may be restricted, depending on the conditions, thus resulting in problems with clamping strength. Study and consider this point thoroughly when designing under such circumstances. In order to achieve maximum performance of the RV reduction gear, assembly accuracy, lubrication and sealing are especially important. Read the following carefully before designing.

6-1 Assembly accuracy

Design the assembly side of the RV reduction gear to the following accuracy. (The following figure shows the RV reduction gear used for shaft revolution. Design it to the same accuracy when using it for case revolution.) Poor accuracy on the assembly side causes noise, vibration or uneven torque in particular.

Fig.11

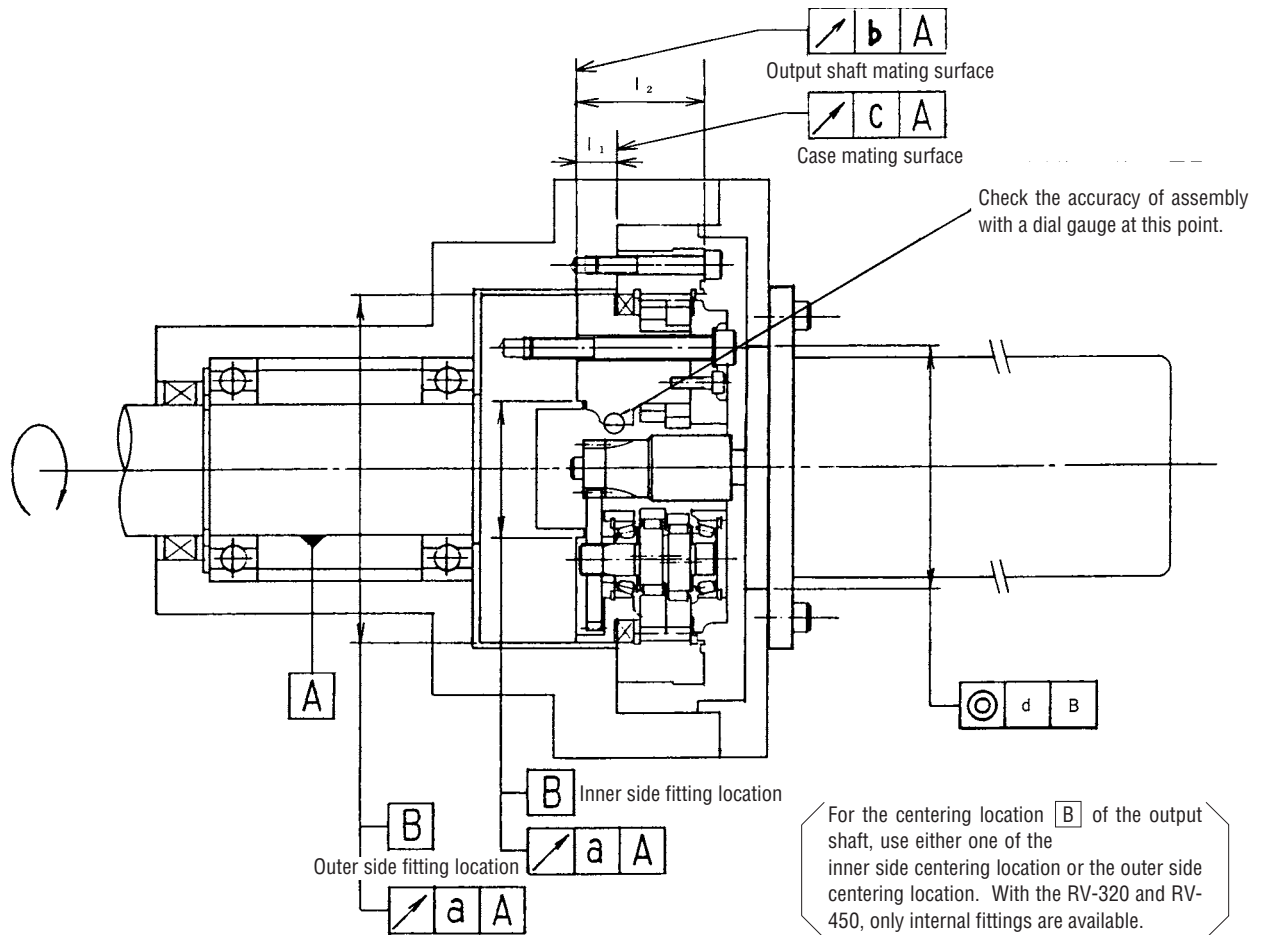

Table 7

(Unit:mm)

Model	Accuracy	Circumferential deflection tolerance Max.a	Circumferential deflection tolerance Max.b	Circumferential deflection tolerance Max.c	Tolerance for concentricity Max.d	Size accuracy for assembly	
						h(mm)	l ₂ (mm)
RV-15		0.02	0.02	0.02	0.05	16±0.5	48 ±0.5
RV-30		0.02	0.02	0.02	0.05	22±0.5	56 ±0.5
RV-60		0.05	0.03	0.03	0.05	19±0.5	61 ±0.5
RV-160		0.05	0.03	0.03	0.05	27±1.0	79 ±1.0
RV-320		0.05	0.03	0.05	0.05	33±1.0	96 ±1.0
RV-450		0.05	0.03	0.05	0.05	35±1.0	107.5±1.0
RV-550		0.05	0.03	0.05	0.05	41±1.0	123 ±1.0

6-2 Installation procedure

6-2-1 RV reduction gear mounting holes

Table 8

	Case	Shaft
I	Through-hole and pin hole	Through-hole and pin hole
II	Threaded hole and pin hole	(Through-hole for RV-15 and RV-30)

Notes 1. Select method I or II so as to meet your requirements.

2. When employing additional pins, refer to Transmission Torque (Article 6-4) and External Dimension (Article 7).

6-2-2 Fitting of RV reduction gear

1) Through-holes

● Socket on the shaft side

Provide the external or internal socket.

● Socket on the case side

Do not provide a socket on the case side except where the case has no fixed position structure such as motor flange with no bearing (See the following figure.).

Fig.12

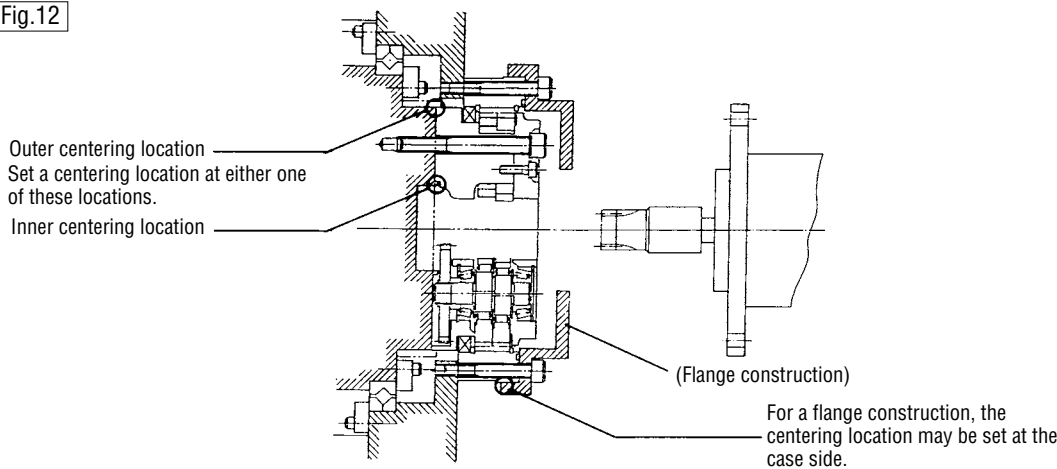

2) Threaded hole

● Socket on the shaft side

Provide the external or internal socket.

● Socket on the case side

Do not provide a socket on the case side (See the following figure.).

Fig.13

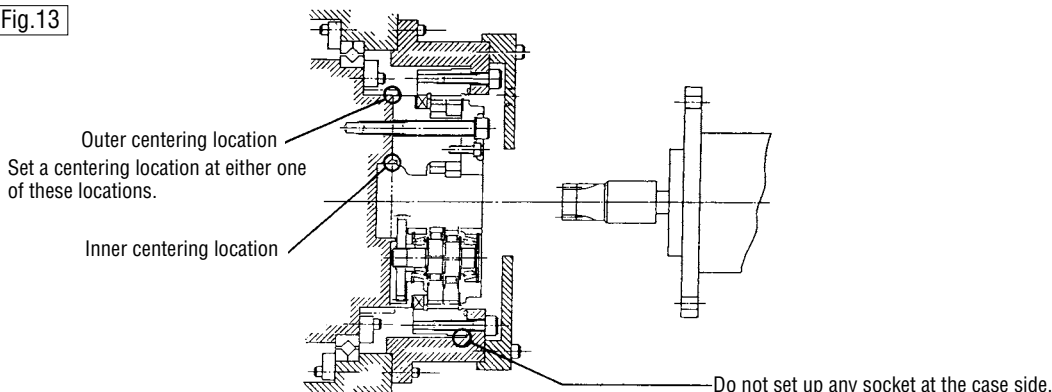

Note : In the RV reduction gear, concentricity on the shaft for reasons in manufacture side slightly offsets from that on the case side. Do not provide any socket on both the shaft and case side. Otherwise, the shaft may rotate eccentric to the case, causing vibration. Do not provide any socket on the case side. To assemble the RV reduction gear, first fasten the shaft side, with the case set free, then fasten the case.

6-3 Installation Procedure

- The typical installation examples for the RV reduction gear are shown below. Be sure to seal the designated type of grease to the designated level. (See page 111)
- Be sure that seals are used between mating parts on the input side. Refer to the O-ring seal installation illustrated.
- If the use of an O-ring seal is impossible because of the design, use Gasket sealant. See Table 9 at right.
- Use outer or inner centering locations for piloting.

Table 9 Recommended Gasket sealant

Manufacturer	Name
Loctite	5699 Grey High Performance RTV Silicone Gasket Maker
Permatex	Moto Seal 2 Ultimate Gasket Maker White

Notes 1. Do not use these sealants for copper material or copper alloy material.
2. If these sealants need to be used under special conditions such as concentrated alkali, pressurized steam, etc., please consult Nabtesco.

6-3-1 Installation of RV-15•RV-30 (with two crankshafts)

Fig.14

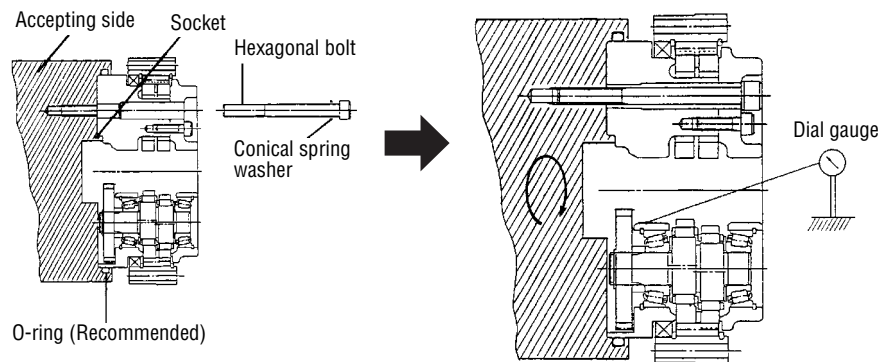

RV-15	G105 (Metric)
RV-30	G135 (Metric)

1. Fit the shaft side of the RV reduction gear to the socket on the installation side.
2. Temporarily tighten the reduction gear shaft and the installation side using the hexagonal socket bolt coupled with belleville spring washer.
- Make sure that the mating face is free from dirt, dust, burrs, etc. before installing the RV reduction gear.

3. Check the RV reduction gear for assembly accuracy using a dial gauge.
 - Turn the RV reduction gear once on the installation side (output shaft side), and check the dial gauge for run-out. In the case of precision control in which vibration is strictly limited, ensure that the run-out on the gauge is 20 μm or less.
 - When employing case revolution, turn the reduction gear on the dial gauge side for measurement.
4. Tighten the hexagonal socket bolt to the specified torque.
 - Recheck the dial gauge for run-out.

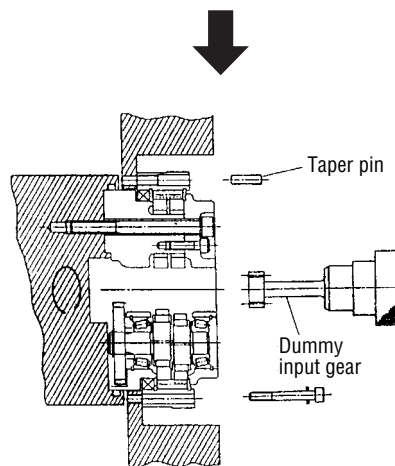

5. Turn the output shaft until the set hole of the case matches the set hole of the body. Temporarily tighten the case using the hexagonal socket bolt with the belleville spring washer.
 - The case may be turned with the input gear or dummy input gear.
6. Make sure that the RV reduction gear is turned by a moderate torque while adjusting the position of the temporary tightening bolt. Finally, tighten the hexagonal socket bolt to the specified torque.
 - If a single spur gear of the RV reduction gear is turned by hand, the spur gear encounters great resistance at two points because of a positional relation of crankshaft phase with RV gear phase. However, this causes no problem.

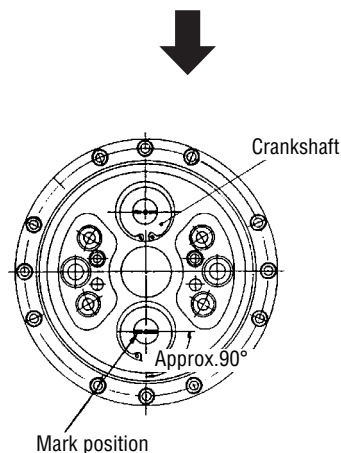

7. Turn the RV reduction gear until the mark on the crankshaft comes to the position illustrated.
8. When using the additional pin, ream the pin hole with a tapered reamer and drive the pin.

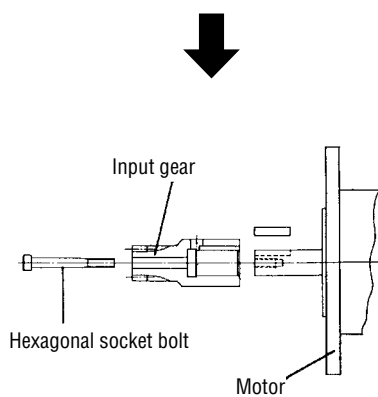

9. Assemble the input gear with the motor shaft.

- The left figure shows that the motor output shaft is straight and female threaded. For other specifications, see the installation example (section 8.3).

10. Supply a lubricant (grease).

- For the quantity of lubricant, refer to Lubrication (section 6-6).
- Recommended lubrication is Nabtesco Molywhite RE00.

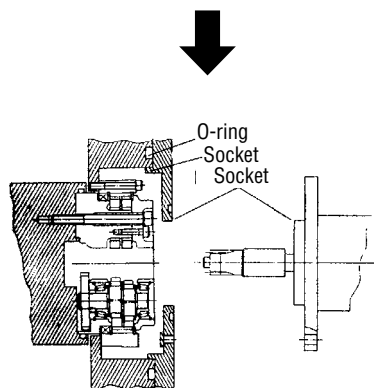

11. Insert the motor shaft into the RV reduction gear, with the motor shaft axis in alignment with the center axis of the reduction gear.

- When inserting the motor shaft, check to make certain that the motor flange face comes into close contact with the mating face of the reduction gear, with no inclination. Never tighten the motor shaft with the motor setting bolt, etc. before assembling.
- If the motor flange face is inclined, the input gear may be out of position (refer to section 6-5-1). Match the mark of the crankshaft with the mark of the motor shaft once again, and insert the motor shaft.
- Crankshaft markings are for proper assembly of the input gear. If the input gear is installed in the wrong place, damage to the servomotor shafts, input gears and spur gears may result.

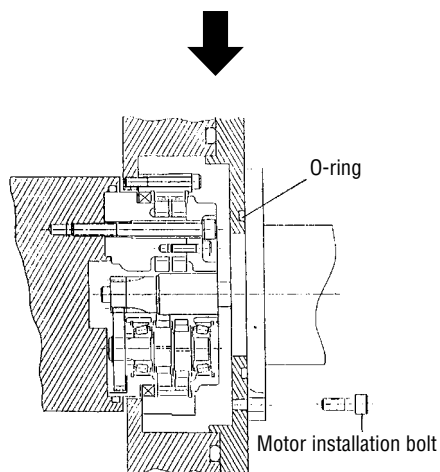

12. Fasten the motor flange to the case using the motor flange mounting bolts.

■6-3-2 Installation of RV-60~RV-550 (with three crankshafts)

Fig.15

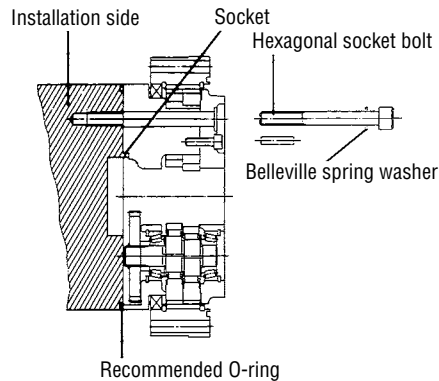

RV-60	AS 568-163
RV-160	AS 568-265
RV-320	AS 568-271
RV-450	AS 568-275

1. Fit the shaft part of the RV reduction gear with the socket of the mated body before assembly.
 2. Temporarily tighten the shaft part of the reduction gear with the mated body using the hexagonal socket bolt with the belleville spring washer.
- Make sure that the mating face is free from dirt, burrs, etc. before installing the RV reduction gear.

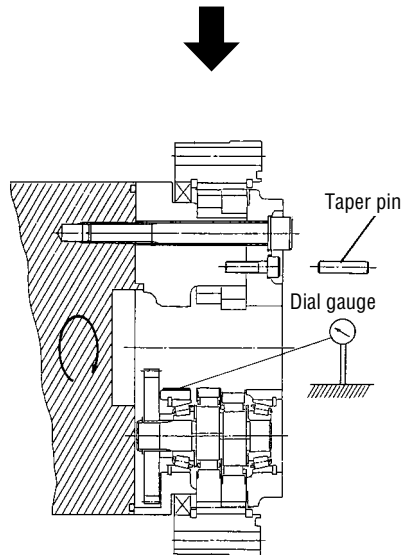

3. Check the RV reduction gear for assembly accuracy using a dial gauge.
- Turn the RV reduction gear once on the installation side (output shaft side), and read the dial gauge for run-out. In the case of precision control in which vibration is strictly limited, ensure that the run-out on the gauge is 20 μ m or less.
 - When employing case revolution, turn the dial gauge side for measurement.
4. Finally, tighten the hexagonal socket bolt to the specified torque.
- Recheck the dial gauge for run-out.
5. When using the additional pin, ream the pin hole with a tapered reamer before driving the pin.

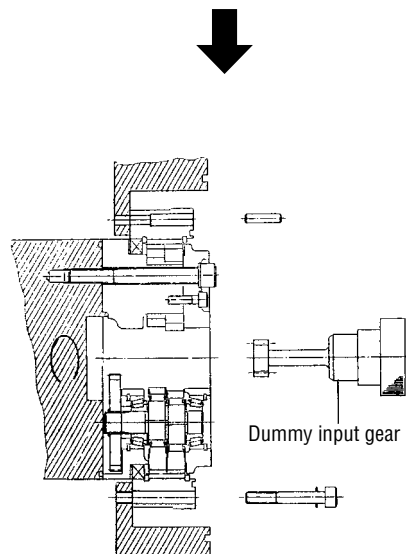

6. Turn the output shaft until the set hole of the case matches the set hole of the mated body. Temporarily tighten the case using the hexagonal socket bolt fitted with belleville spring washer.
- The case may be turned with the input gear or dummy input gear.
7. Make sure that the RV reduction gear is turned by a moderate torque while adjusting the temporary tightening bolt. Finally tighten the hexagonal socket bolt to the specified torque.
- Never tighten the hexagonal socket bolt before adjusting the reduction gear. Otherwise, the gap between the shaft and case may become uneven, thus causing an uneven torque.

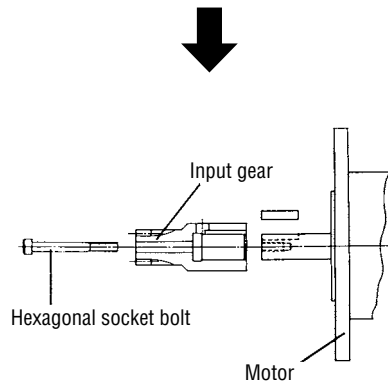

8. When using the additional pin, ream the pin hole with a tapered reamer then drive the pin.
9. Assemble the input gear in the motor shaft.

●The left figure shows that the motor output shaft is straight and female threaded. For other specifications, see the installation example (section 6.5).

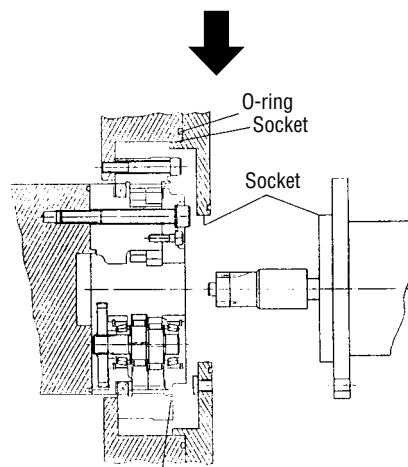

O-ring groove: Details are as per external dimension (section 7).

RV-60	AS568-165
RV-160	With no O-ring groove
RV-320	AS568-178
RV-450	AS568-276
RV-550	*No. 3.5-312

*O-rings for RV-550 are of a special specification. Contact us regarding purchase of these O-rings.

10. Supply a lubricant (grease).

●For the quantity of lubricant, refer to Lubrication (article 6-6).

11. Insert the motor shaft into the RV reduction gear, with the motor shaft axis in alignment with the center axis of the reduction gear.

●When inserting the motor shaft, check to make certain that the motor flange face comes into close contact with the mating face of the reduction gear, with no inclination. Never tighten the motor shaft with the motor setting bolt, etc. before assembling.

●If the input gear is not in alignment with the spur gear, turn the motor shaft a little in the circumferential direction to insert it.

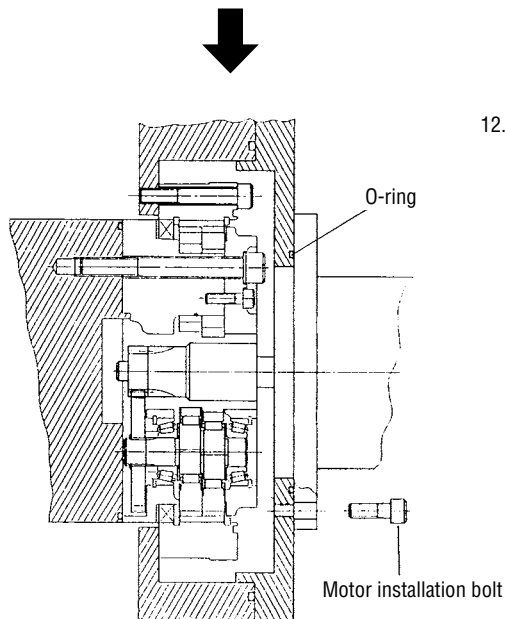

12. Fasten the motor flange to the case using the motor installation bolts.

6-4 Bolt tightening torque and allowable transmission torque

Use hexagonal socket bolts to assemble the RV reduction gear and tighten to the torque as specified below. When the pin/bolt joint output shaft type is used, also use the taper pin. The serrated lock washer is recommended to prevent the bolt from loosening and protect the bolt seat face from flaws.

Table 10 Tightening force (F)

Hexagonal socket bolt nominal size x pitch (mm)	Tightening torque In-lb (Nm)	Tightening force (F) N	Bolt specification
M6 ×1.0	138 ±7 (15.6 ±0.78)	13,181	<ul style="list-style-type: none"> ● Hexagonal socket bolt JIS B 1176 ● Strength class JIS B 1051 12.9 ● Thread JIS B 0205 6g or class 2
M8 ×1.25	329 ±16 (37.2 ±1.86)	23,961	
M10 ×1.5	651 ±30 (73.5 ±3.43)	38,082	
M12 ×1.75	1,137 ±56 (128.4 ±6.37)	55,095	
M14 ×2.0	1,814 ±90 (204.8 ±10.2)	75,861	
M16 ×2.0	2,821 ±141 (318.5 ±15.9)	103,409	

Calculation of allowable transmission torque of bolts

$$T_1 = F \times \frac{D_1}{2} \times \mu \times n_1$$

T_1 : bolt allowable transmission torque (Nm)
 F : bolt tightening force (N)
 D_1 : bolt P.C.D. (m)
 μ : friction factor
 $\mu = 0.15$: where lubricants remained
 $\mu =$ where left dried with no lubricant
 n_1 : number of bolts

Calculation of allowable transmission torque of bolt and additional pin(s)

$$T_2 = T_1 + \frac{\pi d^2}{4} \times \tau \times \frac{D_2}{2} \times n_2$$

T_2 : allowable transmission torque of bolt and additional pin (Nm)
 d : pin diameter (mm)
 τ : pin allowable shearing strength (N/mm²)
 $\tau = 196$: pin material S45C-Q
 D_2 : pin P.C.D. (m)
 n_2 : number of pins

Serrated lock washer external teeth for hexagonal socket bolt

Material: steel
 Hardness: HRC40~48

Fig.17

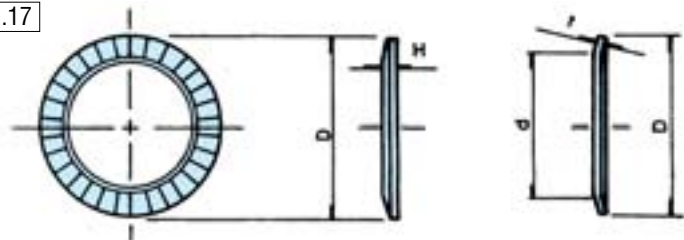

Table 11

(Unit:mm)

Nominal size	ID and OD of washer		t	H
	d	D		
6	6.4	10	1.0	1.25
8	8.4	13	1.2	1.55
10	10.6	16	1.5	1.9
12	12.6	18	1.8	2.2
14	14.6	21	2.0	2.5
16	16.9	24	2.3	2.8

Note: When using any equivalent washer, select it, with special care given to its outside diameter.

6-5 Installation of input gear

- The standard-sized input gear comes from the factory without holes drilled for motor shafts.
- The following are reference drawings for installation of input shafts. Customers must provide set screw, draw bolt and hexagonal nuts. Some low ratio input gears will not fit through the center of the RV gear. See 6-5-2.

Fig.18

Straight shaft

No female threaded on servomotor

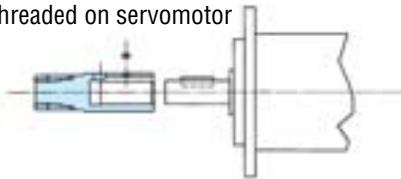

With female threaded on servomotor



Taper shaft

With male threaded on servomotor

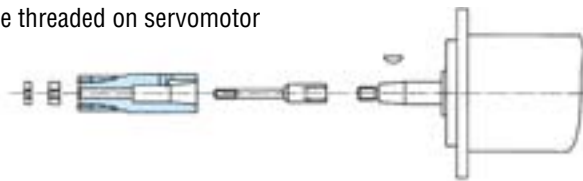

6-5-1 Precautions for installation of RV-15 and 30 input gears

RV-15 and 30 have two spur gears. Special care must be used when installing the input gear to prevent misalignment.

Insert the input gear. If the input gear does not engage with the spur gear, insert the input gear by turning it clockwise or counterclockwise a little. Make sure that the motor flange is fitted closely and squarely. Do not tighten motor mounting screws unless the motor is properly aligned. If the motor flange is at an angle, there is a possibility that the input gear is installed in an incorrect position. (See Fig. 19)

Fig.19

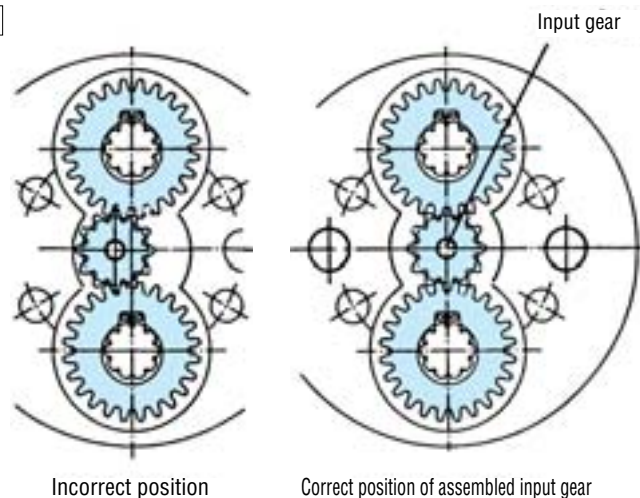

6-5-2 Pass-through capacity of input gear

Lower ratio input gears may have diameters too large to pass through the RV gear center. The following table shows which ratios can and can not allow the input gear to pass through.

Fig.20

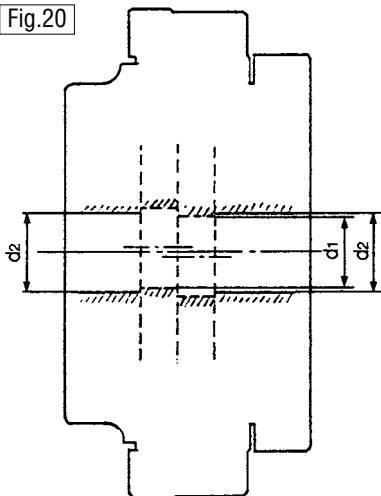

Table 12

Model	Hole dia.		Speed ratio adequate for shaft passage		Speed ratio inadequate for shaft passage	
	d_1	d_2	Shaft revolution		Case revolution	
			Shaft revolution	Case revolution	Shaft revolution	Case revolution
RV-15	22	24	81, 105, 121, 141	80, 104, 120, 140	57	56
RV-30	27	30	81, 105, 121, 153	80, 104, 120, 152	57	56
RV-60	37	40	81, 101, 121, 153	80, 100, 120, 152	57	56
RV-160	43	47	81, 100, 129 145, 171	80, 101, 128 144, 170	*66	*65
RV-320	47	52	81, 101, 118.5 129, 141, 171, 185	80, 100, 117.5 128, 140, 170, 184	*66	*65
RV-450	57	62	81, 101, 118.5, 129 154.84, 171, 192.42	80, 100, 117.5, 128 153.84, 170, 191.42	*66	*65
RV-550	66	72	123, 141, 163.5 192.4	122, 140, 162.5 191.4	—	—

(Unit:mm)

* Not described on the rating table. Please consult Nabtesco if needed.

6-5-3 An example of installation for the reduction gear with lower speed ratio

The lower the speed ratio, the larger the outside diameter of the input gear. Therefore, the installation of the input gear through the reduction gear with motor shaft installed may not be possible.

6-6 Lubrication

To maximize the performance of the RV reduction gear, the use of Molywhite RE00 manufactured by Nabtesco is recommended.

6-6-1 Grease lubrication

Table 13 Brand of recommended lubricant

Grease	
Nabtesco	Molywhite RE00

Note: Do not mix the recommended grease or gear oil with any other lubricant.

Table 14 Working temperature range (ambient temperature)

Working temperature range (ambient temperature)	-10°C ~ 40°C
---	--------------

Note: Please contact Nabtesco if grease or gear oil is to be used beyond the specified temperature range.

1) The quantity of grease required for the RV reduction gear

The RV reduction gear is not greased when it is shipped from the plant. Therefore ensure that necessary amount of recommended grease is charged when installing the RV reduction gear.

Note: Tables 15, 16 show the quantities of grease required for each type of RV reduction gear.

However, the quantities do not include the space between the reduction gear and mating components. Therefore if there are some, they must be charged also.

However, too much filling may causes damage for an oil seal with increase of internal pressure. Please leave about 10% of the room inside.

Table 15 Vertical installation

Type	Quantity	
	cc	(g)
RV-15	101	(88)
RV-30	186	(162)
RV-60	296	(258)
RV-160	514	(447)
RV-320	1,014	(882)
RV-450	1,451	(1,262)
RV-550	2,257	(1,964)

Table 16 Horizontal installation

Type	Quantity	
	cc	(g)
RV-15	88	(77)
RV-30	162	(141)
RV-60	258	(224)
RV-160	448	(390)
RV-320	884	(769)
RV-450	1,453	(1,264)
RV-550	1,967	(1,711)

2) Grease level in RV reduction gear

Vertical installation (1)

Fig.21

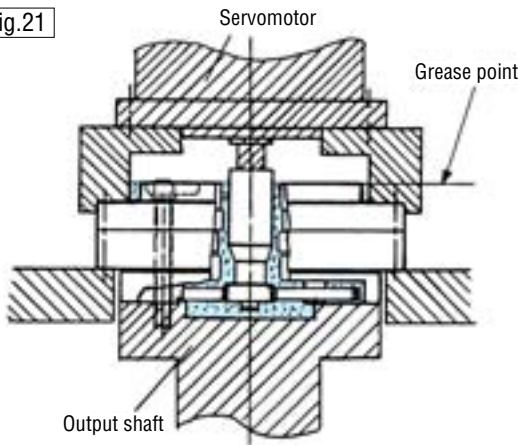

Vertical installation (2)

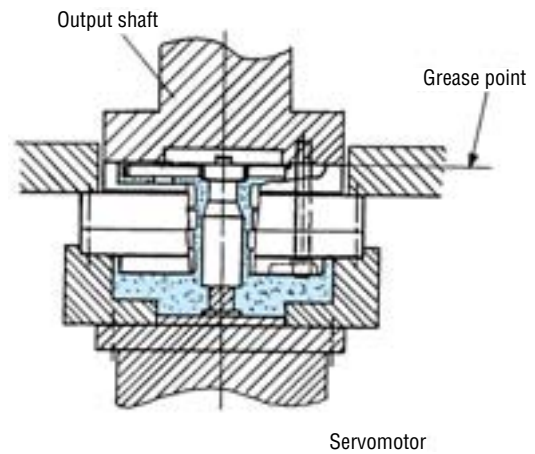

Horizontal installation

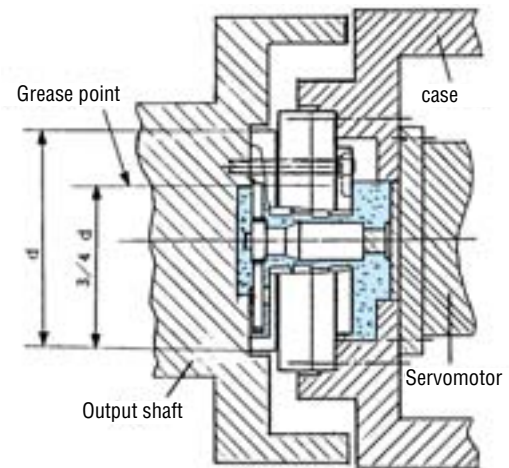

3) Interval between grease changes

Change grease at a standard interval of 20,000 hours after initially supplying the RV reduction gear with grease of the specified quantity (see Fig.21) in order to protect the RV reduction gear from deteriorated grease.

If grease is contaminated for any reason or used at an ambient temperature of 40°C or more, check the grease for contamination or deterioration, to determine the proper maintenance interval.

6-7 Warranty

Nabtesco guarantees that the reduction gears of the model RV are free from defects of materials and workmanship. The term of guarantee shall be one year after delivery or 2,000 hours of operation after the installation on an actual machine, whichever earlier, on condition that the product is operated under the rated operation conditions specified by us, in normal assembly and lubrication condition.

If any defect in materials or workmanship is detected during the above guarantee term, the product will be repaired or substituted at our expense, provided that the No. of man-hour required for demounting and remounting the product from the machine, transportation expense for re-delivery, warehousing and other incidental expenses shall be excluded from our obligation.

No expenses for damages of the machine due to shutdown of operation attributable to defect of the product are guaranteed.

If the guarantee is accomplished with money, the upper limit of the amount shall not exceed the selling price of that claimed product.

7-1 RV-15 External dimensions of through-bolt clamping output shaft type (2 piece input gear)

Speed ratio $\frac{A}{B}$ - T
 Type code RV-15-57-

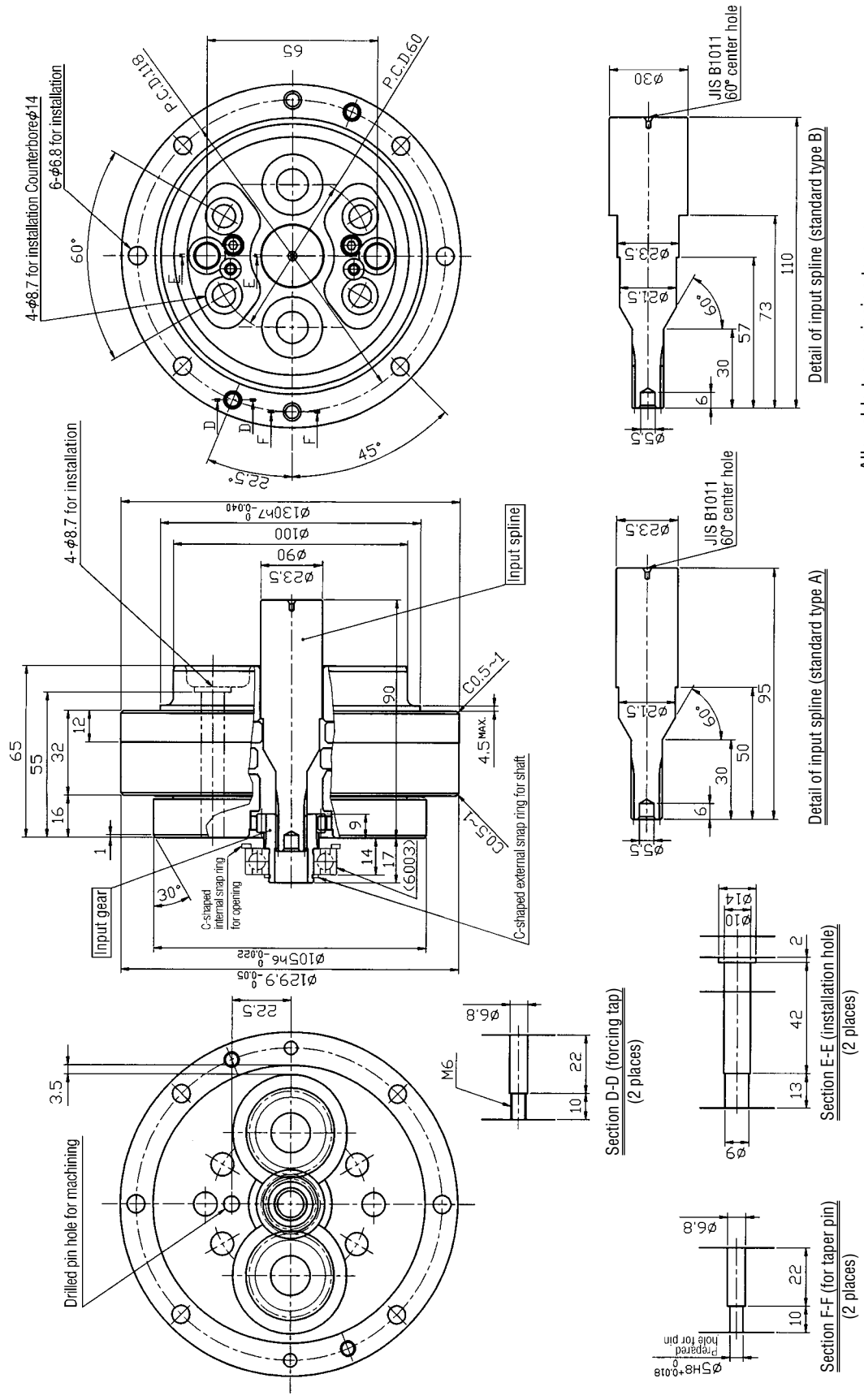

Allowable transmission torque

	Bolt	Taper pin	Total
Case side	699.7Nm	453.7Nm	1,153.4Nm
Shaft side	664.4Nm		664.4Nm

- Notes
1. Uses bolts and tapered pins to connect case and shaft.
 2. Use commercial goods to supply items such as O-rings, mounting bolts, seal washers, deep groove ball bearings, C-shaped snap rings and taper pins.
 3. Specifications and dimensions are subject to change without notice.

7-2 RV-15 External dimensions of through-bolt clamping output shaft type (1 piece input gear)

Speed ratio $\frac{A}{B}$
 Type code RV-15-□-□- $\frac{A}{B}$ -T

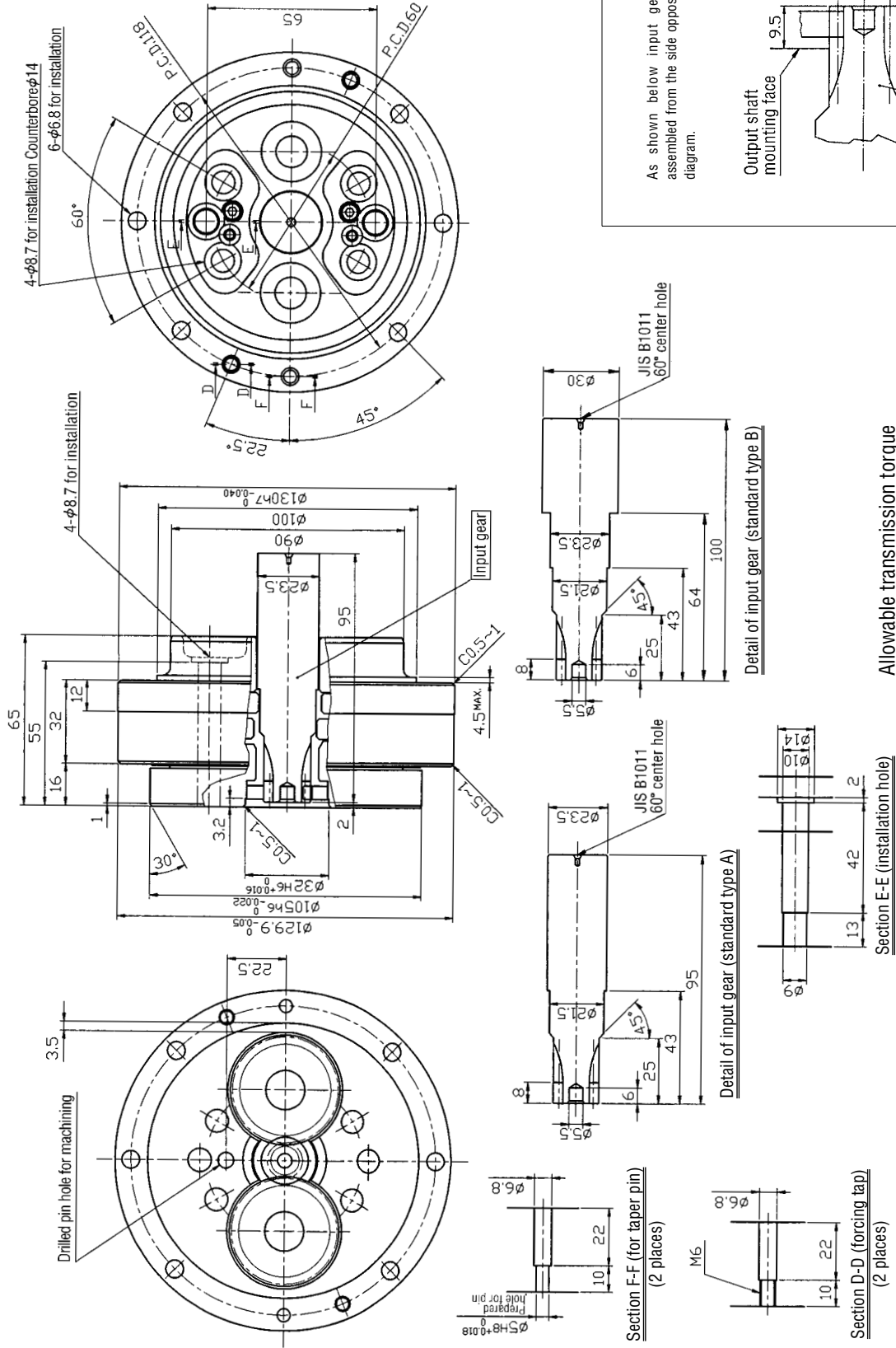

- Notes 1. Uses bolts and tapered pins to connect case and shaft.
 2. Use commercial goods to supply items such as O-rings, mounting bolts, seal washers and taper pins.
 3. Specifications and dimensions are subject to change without notice.

Allowable transmission torque

	Bolt	Taper pin	Total
Case side	699.7Nm	453.7Nm	1,153.4Nm
Shaft side	664.4Nm		664.4Nm

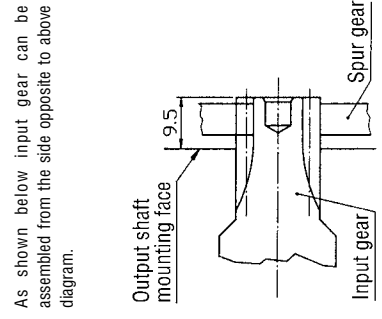

7-3 RV-30 External dimensions of through-bolt clamping output shaft type (2 piece input gear)

Speed ratio **A**-**B**
Type code RV-30-57-A-T

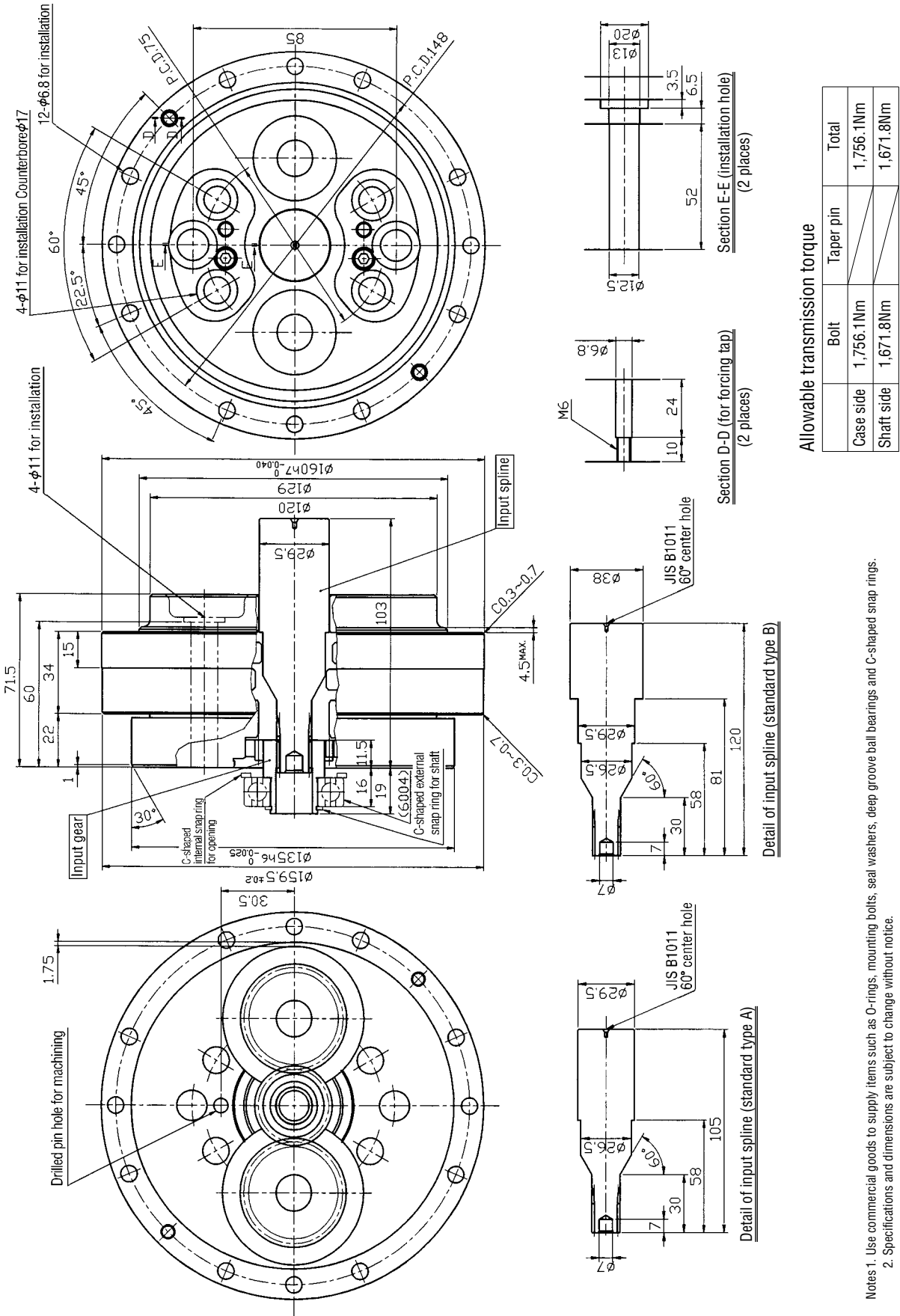

Allowable transmission torque

Bolt		Taper pin	Total
Case side	1,756.1Nm		1,756.1Nm
Shaft side	1,671.8Nm		1,671.8Nm

Notes 1. Use commercial goods to supply items such as O-rings, mounting bolts, seal washers, deep groove ball bearings and C-shaped snap rings.
 2. Specifications and dimensions are subject to change without notice.

7-4 RV-30 External dimensions of through-bolt clamping output shaft type (1 piece input gear)

Speed ratio $\frac{A}{B}$
Type code RV-30- \square - \square - \square -T

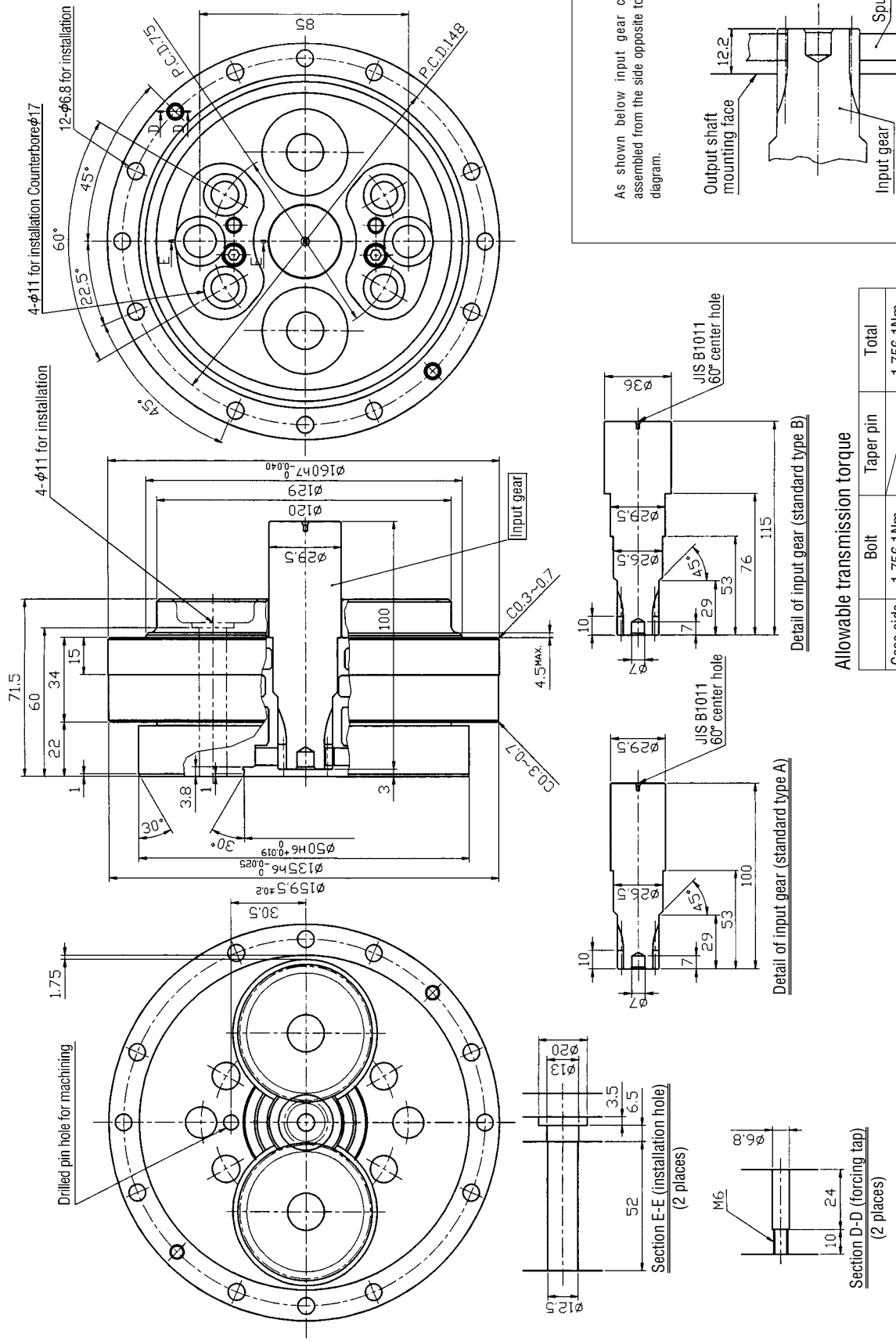

Allowable transmission torque

	Bolt	Taper pin	Total
Case side	1,756.1Nm		1,756.1Nm
Shaft side	1,671.8Nm		1,671.8Nm

As shown below input gear can be assembled from the side opposite to above diagram.

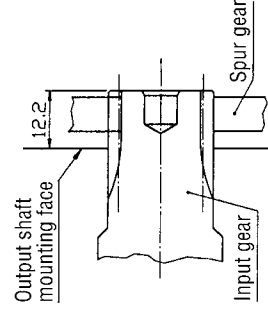

- Notes 1. Use commercial goods to supply items such as O-rings, mounting bolts and seal washers.
- 2. Specifications and dimensions are subject to change without notice.

7-5 RV-60 External dimensions of through-bolt and pin clamping output shaft type (2 piece input gear) Type code RV-60-57-A-B-T

Speed ratio

A/B

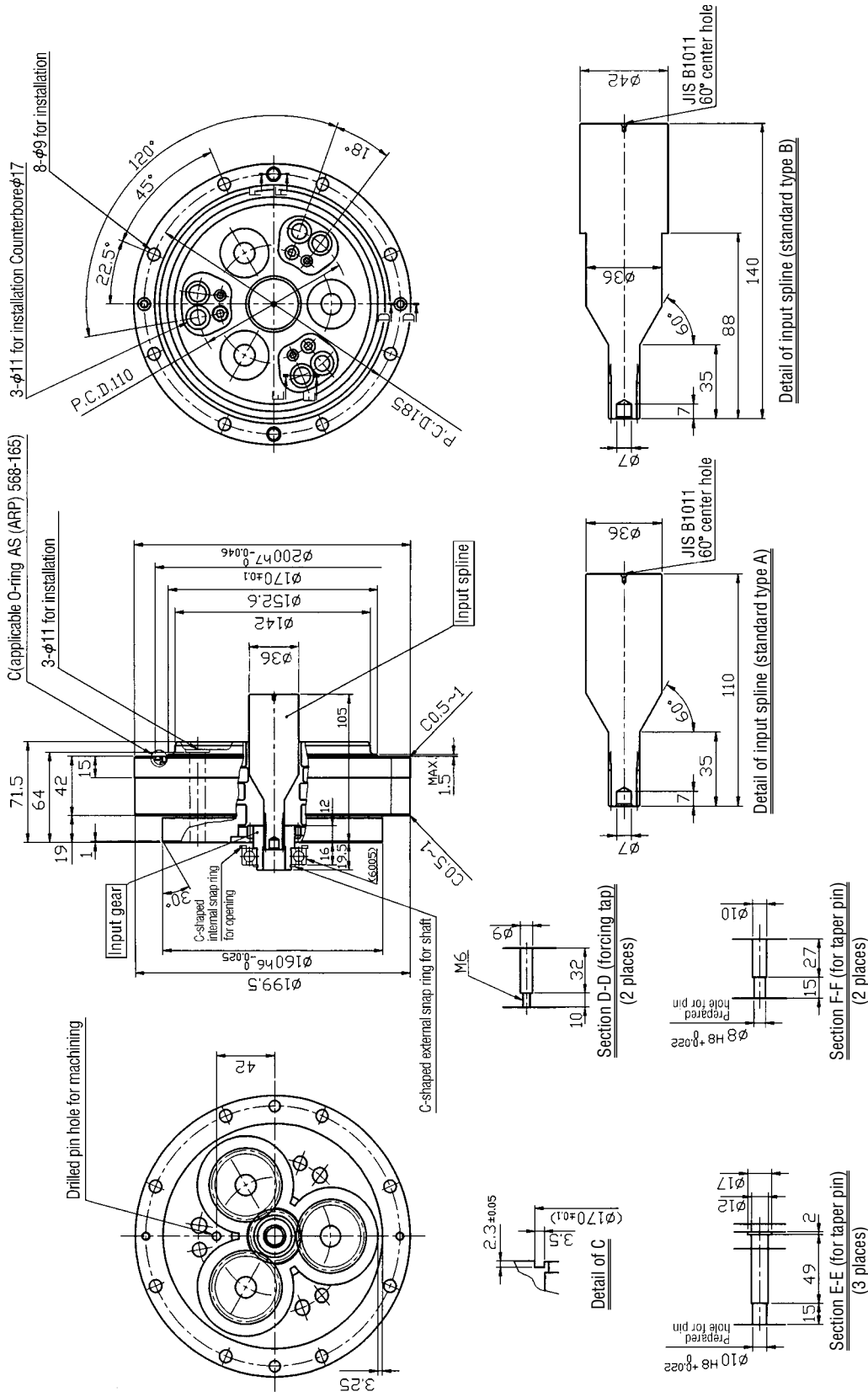

Allowable transmission torque

	Bolt	Taper pin	Total
Case side	2,659.7Nm	1,822.8Nm	4,482.5Nm
Shaft side	942.7Nm	2,540.1Nm	3,482.9Nm

- Notes 1. Uses bolts and tapered pins to connect case and shaft.
- 2. Use commercial goods to supply items such as O-rings, mounting bolts, seal washers, deep groove ball bearings, C-shaped snap rings and taper pins.
- 3. Specifications and dimensions are subject to change without notice.

7-6 RV-60 External dimensions of through-bolt and pin clamping output shaft type (1 piece input gear) Type code RV-60- \square - \square - \square -T

Speed ratio

A
B

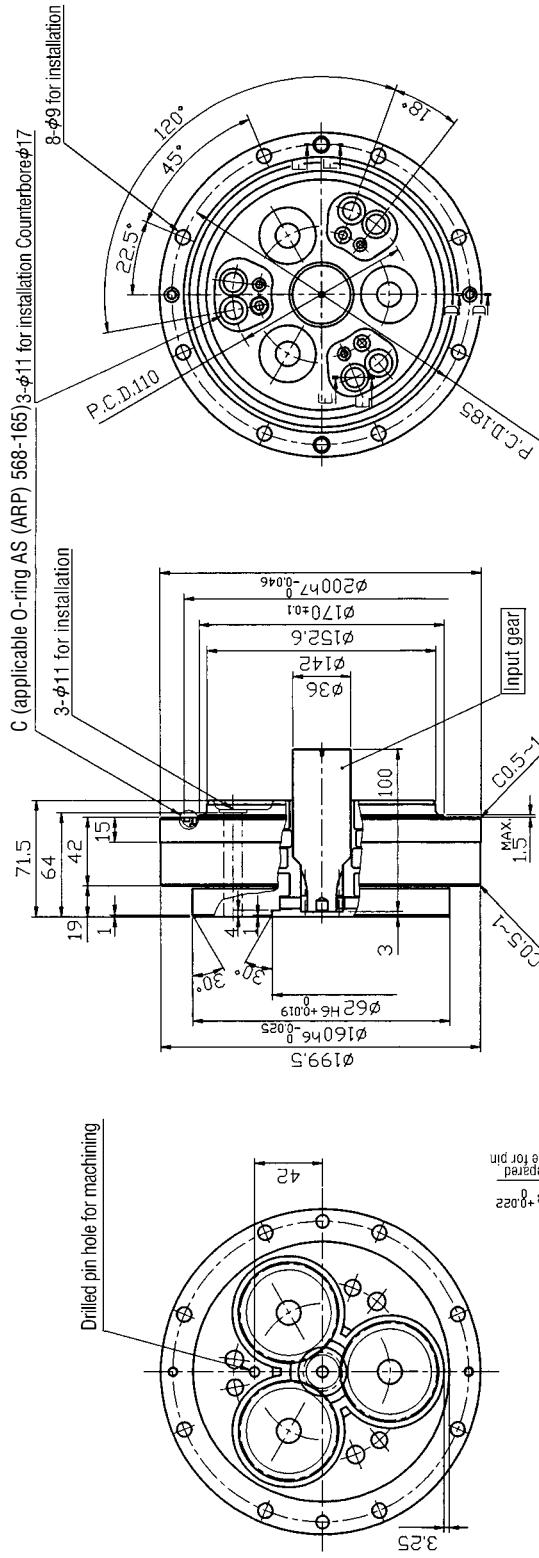

Drilled pin hole for machining

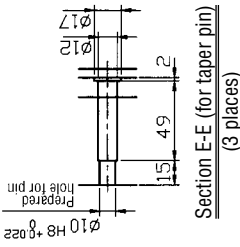
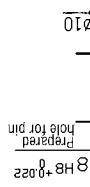

Section E-E (for taper pin)
(3 places)

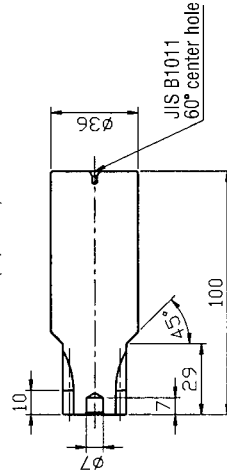

Detail of input gear (standard type A)

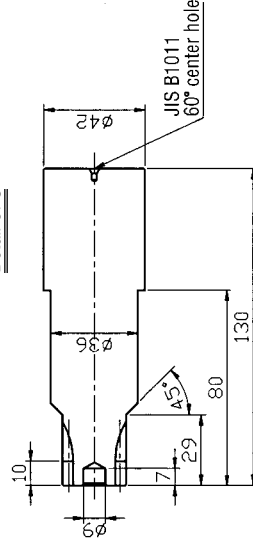

Detail of input gear (standard type B)

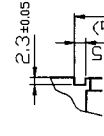

Detail of C

As shown below input gear can be assembled from the side opposite to above diagram.

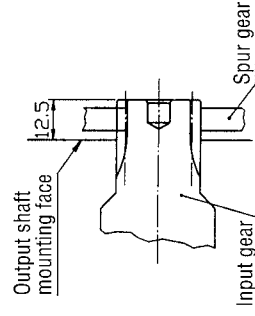

Allowable transmission torque

	Bolt	Taper pin	Total
Case side	2,659.7Nm	1,822.8Nm	4,482.5Nm
Shaft side	942.7Nm	2,540.1Nm	3,482.9Nm

- Notes 1. Uses bolts and tapered pins to connect case and shaft.
2. Use commercial goods to supply items such as O-rings, mounting bolts, seal washers and taper pins.
3. Specifications and dimensions are subject to change without notice.

7-7 RV-160 External dimensions of through-bolt and pin clamping output shaft type (1 piece input gear) Type code RV-160- - - -T

Speed ratio

 - - -T

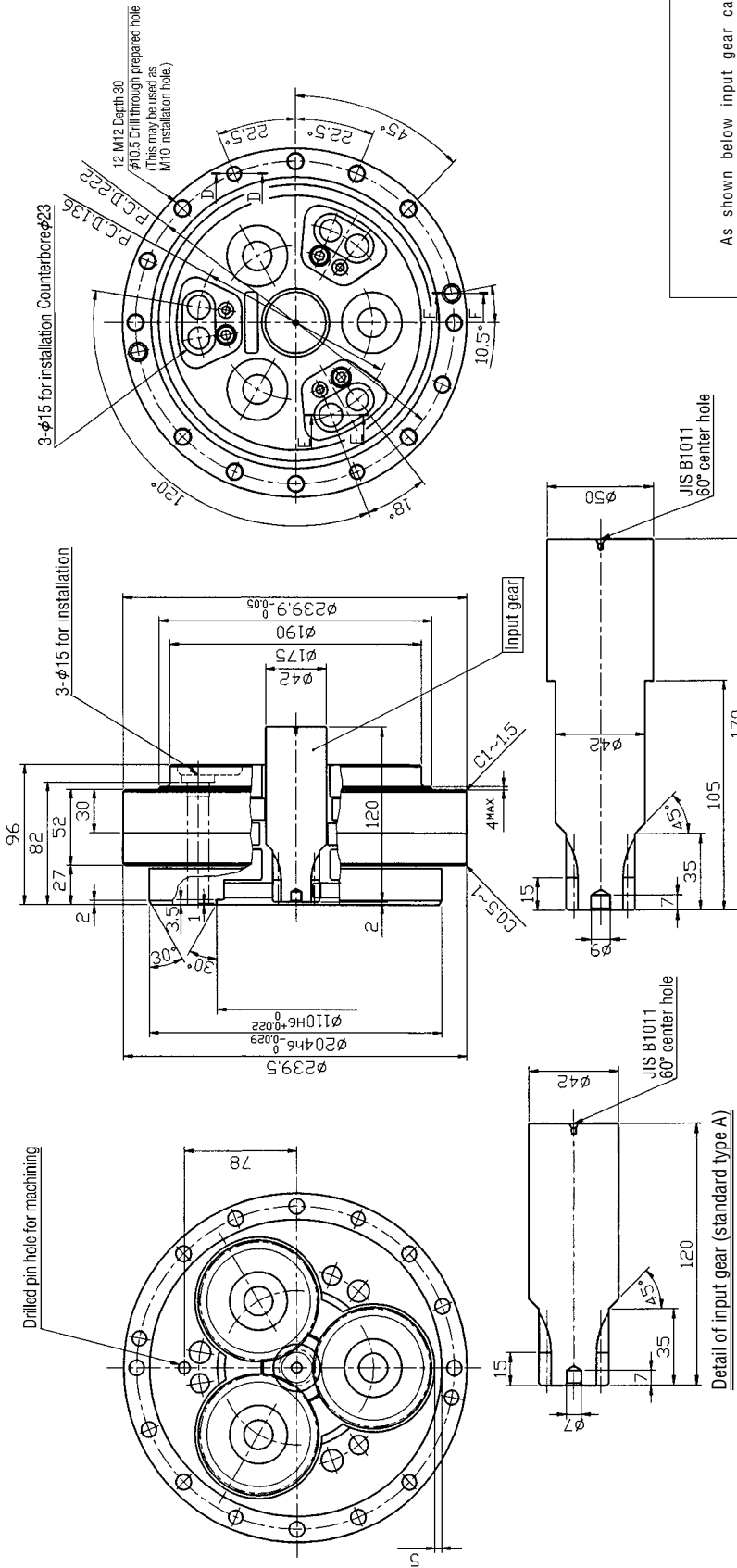

As shown below input gear can be assembled from the side opposite to above diagram.

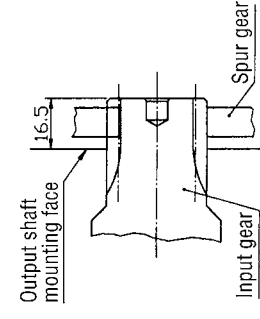

Allowable transmission torque

	Bolt	Taper pin	Total
Case side	7,608.7Nm	3,417.2Nm	11,025.9Nm
Shaft side	2,321.6Nm	5,306.7Nm	7,628.3Nm

- Notes 1. The input gear profile is different when reduction gear ratio is small (i=1/66). Refer to page 109.
 2. Uses bolts and tapered pins to connect case and shaft.
 3. Use commercial goods to supply items such as O-rings, mounting bolts, seal washers and taper pins.
 4. Specifications and dimensions are subject to change without notice.

7-10 RV-550 External dimensions of through-bolt clamping output shaft type (1 piece input gear) Type code RV-550-□-□-A-T

Speed ratio

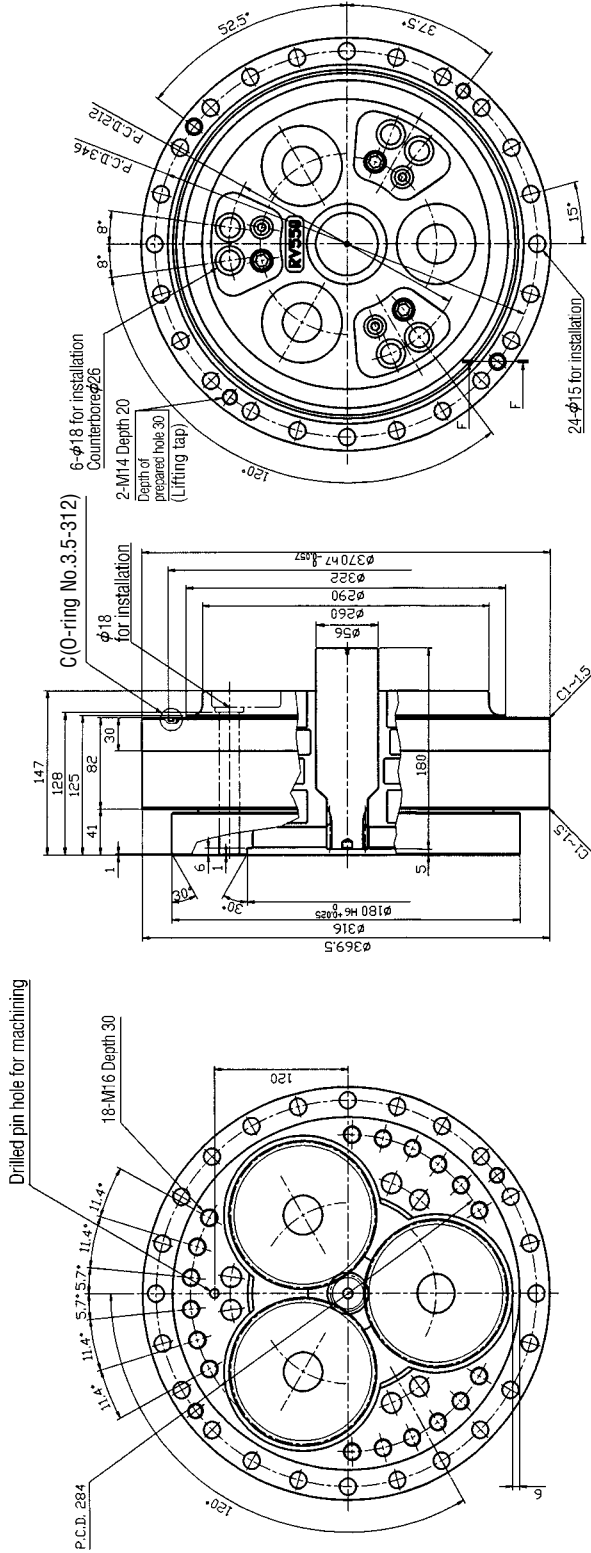

As shown below input gear can be assembled from the side opposite to above diagram.

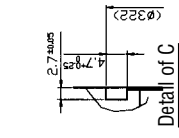
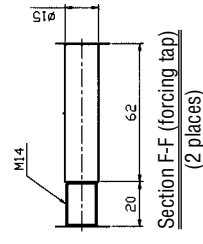
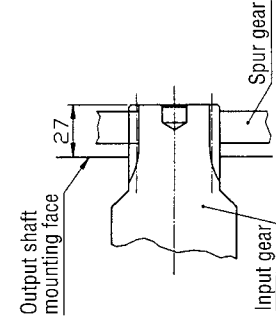

Allowable transmission torque

		Bolt	Taper pin	Total
Case side		47,245.8Nm		47,245.8Nm
Shaft side		49,509.6Nm		49,509.6Nm

- Notes 1. Contact Niblesco when using O-rings.
2. Use commercial goods to supply items such as O-rings, mounting bolts and seal washers.
3. Specifications and dimensions are subject to change without notice.

7-11 RV-160 External dimensions of bolt and pin clamping output shaft type (1 piece input gear) Type code RV-160-A-B-B

Speed ratio

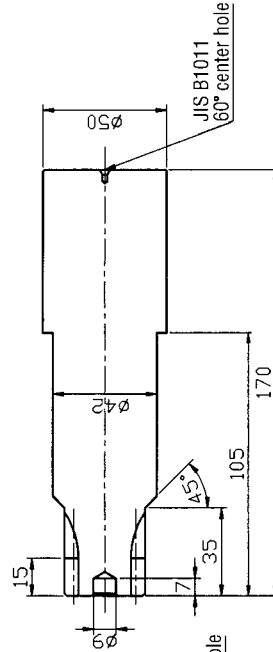
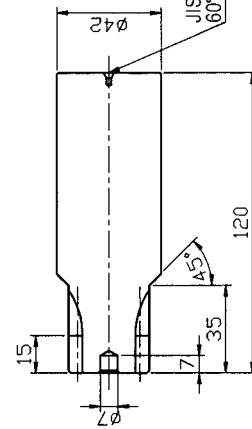
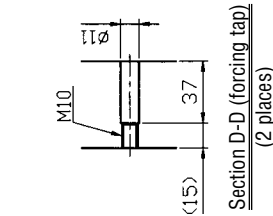
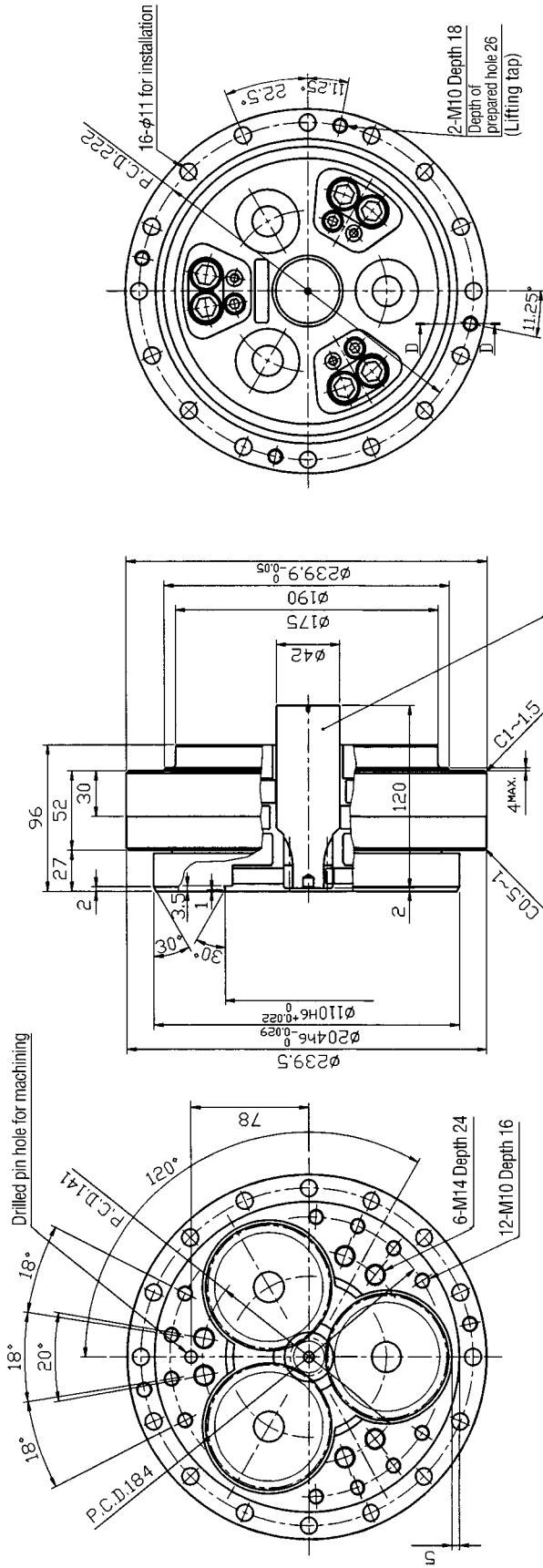

As shown below input gear can be assembled from the side opposite to above diagram.

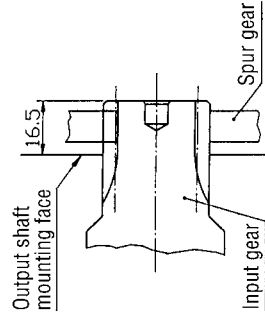

Allowable transmission torque

	Bolt	Taper pin	Total
Case side	10,143Nm		10,143Nm
Shaft side	11,123Nm		11,123Nm

- Notes 1. The input gear profile is different when reduction gear ratio is small ($i=1/66$). Refer to page 109.
2. Use commercial goods to supply items such as mounting bolts and seal washers.
3. Specifications and dimensions are subject to change without notice.

7-13 RV-450 External dimensions of bolt clamping output shaft type (1 piece input gear)

Speed ratio $\frac{A}{B}$
 Type code RV-450-□-□- $\frac{A}{B}$ -B

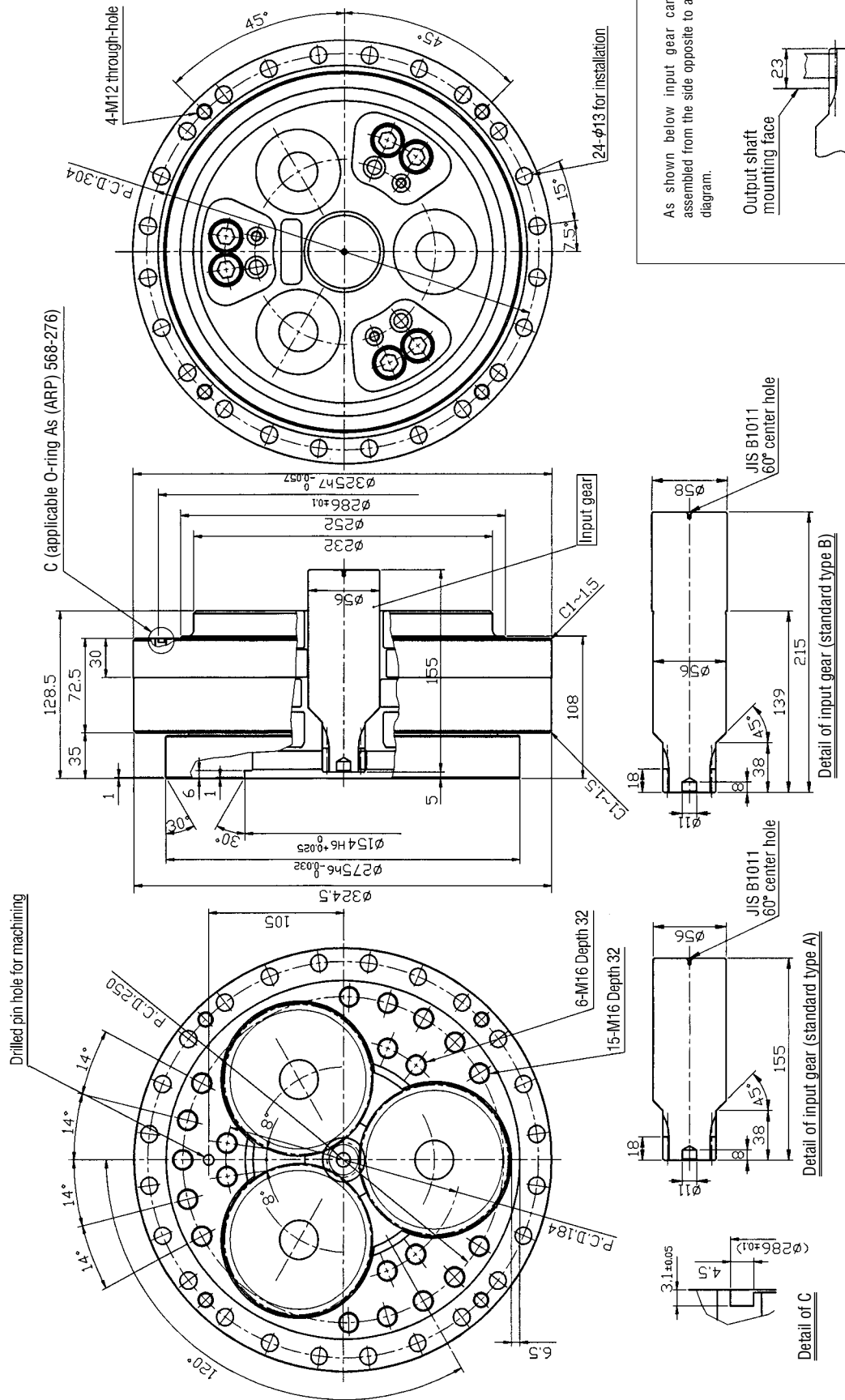

Allowable transmission torque

	Bolt	Taper pin	Total
Case side	30,144.8Nm		30,144.8Nm
Shaft side	37,641.8Nm		37,641.8Nm

As shown below input gear can be assembled from the side opposite to above diagram.

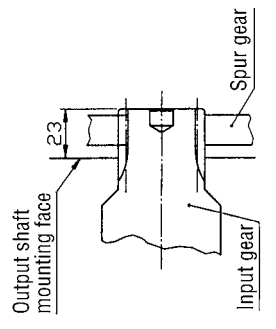

- Notes 1. The input gear profile is different when reduction gear ratio is small ($i=1/66$). Refer to page 111.
 2. Use commercial goods to supply items such as O-rings, mounting bolts and seal washers.
 3. Specifications and dimensions are subject to change without notice.

8 APPLICATION WORKSHEET

☒ Please supply us the following items when ordering RV series Reduction Gears.

1. How used

Name of Machine: _____
 Applied to: _____

2. Model

RV- _____

3. Conditions of Load

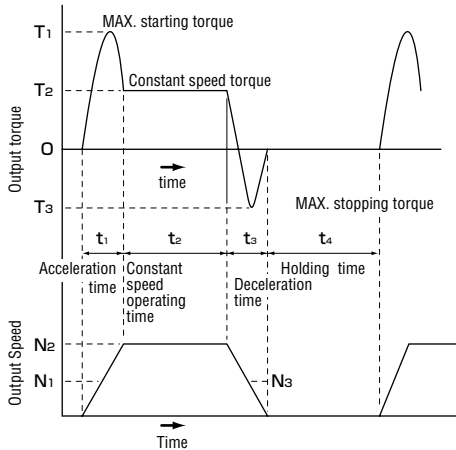

	For starting (MAX)	For constant speed	For stopping (MAX)	Holding time
Load torque in tbs	T ₁	T ₂	T ₃	—
Speed r/min	N ₁	N ₂	N ₃	—
Time sec.	t ₁	t ₂	t ₃	t ₄

Working hours _____ Cycle/day: _____ Day/Year: _____ Year _____

4. External Load Conditions

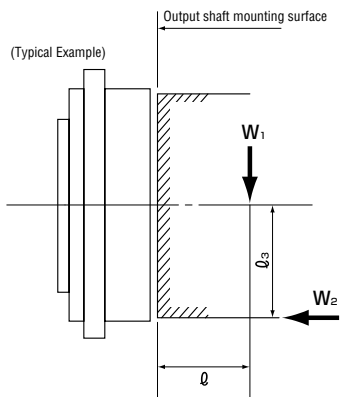

(W₁) : _____ (l) : _____
 (W₂) : _____ (l₃) : _____

5. Installation

Horizontal Vertical (Upper motor)
Lower Motor)

Illustration for installation

6. Input Gear Specification

Reduction speed ratio: i= _____
Standard size, Other
 Input gear: Prepared by, User, TS Corporation

Required dimension of input gear (Illustration)

7. Driving Portion (Servo Motor)

(Manufacturer : _____)
 (Model : _____)
 Capacity: _____ kW
 Rated torque: _____ Nm
 Speed: _____ r/min
 Shape of the shaft with keyway without keyway
Straight Taper

8. Others

(_____)

Nabtesco

Molywhite RE00 Ordering Information

Package

Contents	Part Number	Quantity
400g tube	M/W-400G	1 tube
		1 case (20 tubes)
2kg can	M/W-2KG	1 can
		1 case (6 cans)
16kg pail	M/W-16KG	1 pail
170kg drum	M/W-170KG	1 drum

Contact Information

North & South America (Nabtesco Motion Control, Inc.)

Phone : 1-248-553-3020 Fax : 1-248-553-3070

E-mail : info@nabtescomotion.com

Europe & Africa (Nabtesco Precision Europe GmbH)

Phone : +49-211-173790 Fax : +49-211-364677

E-mail : info@nabtesco-precision.de

RV-E Series Bolt Clamping Output Shaft Type Part Numbers

Model	Ratio	Body with A type Input Gear			Body with B type Input Gear			Body without Input Gear
		A type Input Gear Part Number	A type Input Gear Part Number	A type Input Spline Part Number	B type Input Gear Part Number	B type Input Gear Part Number	B type Input Spline Part Number	
RV-6E	31	P15E001B00	P10J156A0	P15J140-0				P15E001D00
	43	P15E002B00	P10J155A0	P15J140-0				P15E002D00
	53.5	P15E003B00	P10J154A0					P15E003D00
	59	P15E004B00	P10J153A0					P15E004D00
	79	P15E005B00	P10J152A0					P15E005D00
	103	P15E006B00	P10J151A0					P15E006D00
RV-20E	57	P25E011B00	P25J156-0	P25E140-0	P25E011F00	P25J156-0	P25J140Z0	P25E011D00
	81	P25E012B00	P25E153-0		P25E012F00	P25E153A0		P25E012D00
	105	P25E013B00	P25E154-0		P25E013F00	P25E154A0		P25E013D00
	121	P25E014B00	P25E152-0		P25E014F00	P25E152A0		P25E014D00
	141	P25E015B00	P25E151-0		P25E015F00	P25E151A0		P25E015D00
	161	P25E016B00	P25E150-0		P25E016F00	P25E150A0		P25E016D00
RV-40E	57	P35E011B00	P35J156-0	P35J140-0	P35E011F00	P35J156-0	P35J140Z0	P35E011D00
	81	P35E012B00	P30J155-1		P35E012F00	P30J155A0		P35E012D00
	105	P35E013B00	P30J154-1		P35E013F00	P30J154A0		P35E013D00
	121	P35E014B00	P30J152-1		P35E014F00	P30J152A0		P35E014D00
	153	P35E015B00	P30J150-1		P35E015F00	P30J150A0		P35E015D10
RV-80E	57	P45E011B00	P45J156-0	P45J140A0	P45E011F00	P45J156-0	P45J140Z1	P45E011D00
	81	P45E012B00	P45J155-0		P45E012F00	P45J155A0		P45E012D00
	101	P45E013B00	P40J154-0		P45E013F00	P40J154A0		P45E013D00
	121	P45E014B00	P40J152-0		P45E014F00	P40J152A0		P45E014D00
	153	P45E015B00	P40J150-0		P45E015F00	P40J150A0		P45E015D00
RV-110E	81	P48E012B00	P48J150-0					P48E012D00
	111	P48E013B00	P48J151-0					P48E013D00
	161	P48E014B00	P48J152-0					P48E014D00
	175.28	P48E015B00	P48J153-0					P48E015D00
RV-160E	66	P55E011B00	P55J156-0	P55J140-0	P55E011F00	P55J156-0	P55J140Z0	
	81	P55E012B00	P51J155-0		P55E012F00	P51J155A0		P55E012D00
	101	P55E013B00	P51J154-0		P55E013F00	P51J154A0		P55E013D00
	129	P55E014B00	P51J152-0		P55E014F00	P51J152A0		P55E014D00
	171	P55E015B00	P51J151-0		P55E015F00	P51J151A0		P55E015D00
	145	P55E016B00	P51J156-0		P55E016F00	P51J156A0		P55E016D00
RV-320E	81	P65E012B00	P60J155-0		P65E012F00	P60J155A0		P65E012D00
	101	P65E013B00	P60J154-0		P65E013F00	P60J154A0		P65E013D00
	118.5	P65E014B00	P60J153-0		P65E014F00	P60J153A0		P65E014D00
	129	P65E015B00	P60J152-0		P65E015F00	P60J152A0		P65E015D00
	171	P65E016B00	P60J151-0		P65E016F00	P60J151A0		P65E016D00
	185	P65E017B00	P60J150-0		P65E017F00	P60J150A0		P65E017D00
	141	P65E018B00	P60J157-0		P65E018F00	P60J157A0		P65E018D00
RV-450E	81	P76E011B00	P70J155-0		P76E011F00	P70J155A0		P76E011D00
	101	P76E012B00	P70J154-0		P76E012F00	P70J154A0		P76E012D00
	118.5	P76E013B00	P70J153-0		P76E013F00	P70J153A0		P76E013D00
	129	P76E014B00	P70J152-0		P76E014F00	P70J152A0		P76E014D00
	154.84	P76E015B00	P70J157-1		P76E015F00	P70J157A0		P76E015D00
	171	P76E016B00	P70J151-0		P76E016F00	P70J151A0		P76E016D00
	192.42	P76E017B00	P70J150-0		P76E017F00	P70J150A0		P76E017D00

RV-E Series Bolt & Pin Clamping Output Shaft Type Part Numbers

Model	Ratio	Body with	A type Input Gear	A type Input Spline	Body with	B type Input Gear	B type Input Spline	Body without
		A type Input Gear Part Number	Part Number	Part Number	B type Input Gear Part Number	Part Number	Part Number	Input Gear Part Number
RV-6E	31							
	43							
	53.5							
	59							
	79							
	103							
RV-20E	57	P25E001B00	P25J156-0	P25E140-0	P25E001F00	P25J156-0	P25J140Z0	P25E001D00
	81	P25E002B00	P25E153-0		P25E002F00	P25E153A0		P25E002D00
	105	P25E003B00	P25E154-0		P25E003F00	P25E154A0		P25E003D00
	121	P25E004B00	P25E152-0		P25E004F00	P25E152A0		P25E004D00
	141	P25E005B00	P25E151-0		P25E005F00	P25E151A0		P25E005D00
	161	P25E006B00	P25E150-0		P25E006F00	P25E150A0		P25E006D00
RV-40E	57	P35E001B00	P35J156-0	P35J140-0	P35E001F00	P35J156-0	P35J140Z0	P35E001D00
	81	P35E002B00	P30J155-1		P35E002F00	P30J155A0		P35E002D00
	105	P35E003B00	P30J154-1		P35E003F00	P30J154A0		P35E003D00
	121	P35E004B00	P30J152-1		P35E004F00	P30J152A0		P35E004D00
	153	P35E005B00	P30J150-1		P35E005F00	P30J150A0		P35E005D10
RV-80E	57	P45E001B00	P45J156-0	P45J140A0	P45E001F00	P45J156-0	P45J140Z1	P45E001D00
	81	P45E002B00	P45J155-0		P45E002F00	P45J155A0		P45E002D00
	101	P45E003B00	P40J154-0		P45E003F00	P40J154A0		P45E003D00
	121	P45E004B00	P40J152-0		P45E004F00	P40J152A0		P45E004D00
RV-160E	81	P55E002B00	P51J155-0		P55E002F00	P51J155A0		P55E002D00
	101	P55E003B00	P51J154-0		P55E003F00	P51J154A0		P55E003D00
	129	P55E004B00	P51J152-0		P55E004F00	P51J152A0		P55E004D00
	171	P55E005B00	P51J151-0		P55E005F00	P51J151A0		P55E005D00
	145	P55E006B00	P51J156-0		P55E006F00	P51J156A0		P55E006D00
RV-320E	81	P65E002B00	P60J155-0		P65E002F00	P60J155A0		P65E002D00
	101	P65E003B00	P60J154-0		P65E003F00	P60J154A0		P65E003D00
	118.5	P65E004B00	P60J153-0		P65E004F00	P60J153A0		P65E004D00
	129	P65E005B00	P60J152-0		P65E005F00	P60J152A0		P65E005D00
	171	P65E006B00	P60J151-0		P65E006F00	P60J151A0		P65E006D00
	185	P65E007B00	P60J150-0		P65E007F00	P60J150A0		P65E007D00
	141	P65E008B00	P60J157-0		P65E008F00	P60J157A0		P65E008D00
RV-450E	81	P76E001B00	P70J155-0		P76E001F00	P70J155A0		P76E001D00
	101	P76E002B00	P70J154-0		P76E002F00	P70J154A0		P76E002D00
	118.5	P76E003B00	P70J153-0		P76E003F00	P70J153A0		P76E003D00
	129	P76E004B00	P70J152-0		P76E004F00	P70J152A0		P76E004D00
	154.84	P76E015B00	P70J157-1		P76E015F00	P70J157A0		P76E015D00
	171	P76E006B00	P70J151-0		P76E006F00	P70J151A0		P76E006D00
	192.42	P76E007B00	P70J150-0		P76E007F00	P70J150A0		P76E007D00

RV-C Series Bolt Clamping Output Shaft Type Part Numbers

		Body with Center Gear	Center Gear	Body Without Center Gear
Model	Ratio	Part Number	Part Number	Part Number
RV-10C	27	P10L010-00	P10L190A0	P10L014-00
RV-27C	36.57	P21L014-00	P20L190A1	P21L015-00
RV-50C	32.54	P31L013-00	P30L190B0	P31L014-00
RV-100C	36.75	P41L014-00	P40L190-0	P41L017-00
RV-200C	34.86	P51L005-00	P50L190-1	P51L009-00
RV-320C	35.61	P65L021-00	P60L190-0	P65L023-00
RV-500C	37.34		P75L908-0	P76L004-00

RV-C Series Through-Bolt Clamping Output Shaft Type Part Numbers

		Body with Center Gear	Center Gear	Body Without Center Gear
Model	Ratio	Part Number	Part Number	Part Number
RV-10C	27	P10L017-00	P10L190A0	P10L018-00
RV-27C	36.57	P21L018-00	P20L190A1	P21L019-00
RV-50C	32.54	P31L012-00	P30L190B0	P31L015-00
RV-100C	36.75	P41L013-00	P40L190-0	P41L018-00
RV-200C	34.86	P51L004-00	P50L190-1	P51L010-00
RV-320C	35.61	P65L013-00	P60L190-0	P65L002-11

RV Series Through-Bolt Clamping Output Shaft Type Part Numbers

Model	Ratio	Body with			Body with			Body without Input Gear
		A type Input Gear Part Number	A type Input Gear Part Number	A type Input Spline Part Number	B type Input Gear Part Number	B type Input Gear Part Number	B type Input Spline Part Number	
RV-15	57	P20J001B10-Z	P25J156-0	P25J140-0	P20J001F00	P25J156-0	P25J140Z0	P20J001D00
	81	P20J002B10-Z	P20J155-1		P20J002F00	P20J155A0		P20J002D00
	105	P20J003B10-Z	P20J154-1		P20J003F00	P20J154A0		P20J003D00
	121	P20J004B10-Z	P20J152-1		P20J004F00	P20J152A0		P20J004D00
	141	P20J005B00	P20J150-0		P20J005F00	P20J150A0		P20J005D00
RV-30	57	P30J001B11-Z	P35J156-0	P35J140-0	P30J001F00	P35J156-0	P35J140Z0	P30J001D00
	81	P30J002B11-Z	P30J155-1		P30J002F00	P30J155A0		P30J002D00
	105	P30J003B11-Z	P30J154-1		P30J003F00	P30J154A0		P30J003D00
	121	P30J004B11-Z	P30J152-1		P30J004F00	P30J152A0		P30J004D00
	153	P30J005B11-Z	P30J150-1		P30J005F00	P30J150A0		P30J005D00
RV-60	57	P40J001B11	P45J156-0	P45J140A0	P40J001F00	P45J156-0	P45J140Z1	P40J001D00
	81	P40J002B11	P45J155-0		P40J002F00	P45J155A0		P40J002D00
	101	P40J003B11	P40J154-0		P40J003F00	P40J154A0		P40J003D00
	121	P40J004B11	P40J152-0		P40J004F00	P40J152A0		P40J004D00
	153	P40J005B11	P40J150-0		P40J005F00	P40J150-0		P40J005D00
RV-160	81	P50E002B00	P51J155-0		P50E002F00	P51J155A0		P50E002D00
	101	P50E003B00	P51J154-0		P50E003F00	P51J154A0		P50E003D00
	129	P50E004B00	P51J152-0		P50E004F00	P51J152A0		P50E004D00
	171	P50E005B00	P51J151-0		P50E005F00	P51J151A0		P50E005D00
	145	P50E006B00	P51J156-0		P50E006F00	P51J156A0		P50E006D00
RV-320	81	P60E002B00	P60J155-0		P60E002F00	P60J155A0		P60E002D00
	101	P60E003B00	P60J154-0		P60E003F00	P60J154A0		P60E003D00
	118.5	P60E004B00	P60J153-0		P60E004F00	P60J153A0		P60E004D00
	129	P60E005B00	P60J152-0		P60E005F00	P60J152A0		P60E005D00
	171	P60E006B00	P60J151-0		P60E006F00	P60J151A0		P60E006D00
	185	P60E007B00	P60J150-0		P60E007F00	P60J150A0		P60E007D00
	141	P60E008B00	P60J157-0		P60E008F00	P60J157A0		P60E008D00
RV-450	81	P71E001B00	P70J155-0		P71E001F00	P70J155A0		P71E001D00
	101	P71E002B00	P70J154-0		P71E002F00	P70J154A0		P71E002D00
	118.5	P71E003B00	P70J153-0		P71E003F00	P70J153A0		P71E003D00
	129	P71E004B00	P70J152-0		P71E004F00	P70J152A0		P71E004D00
	154.84	P71E005B00	P70J157-1		P71E005F00	P70J157A0		P71E005D00
	171	P71E006B00	P70J151-0		P71E006F00	P70J151A0		P71E006D00
	192.42	P71E007B00	P70J150-0		P71E007F00	P70J150A0		P71E007D00
RV-550	123	P80J002B00	P80J152-0					P80J002D00
	141	P80J003B00	P80J153-0					P80J003D00
	163.5	P80J004B00	P80J151-0					P80J004D00
	192.4	P80J005B00	P80J150-0					P80J005D00

RV Series Bolt Clamping Output Shaft Type Part Numbers

Model	Ratio	Body with	A type Input Gear	A type Input Spline	Body with	B type Input Gear	B type Input Spline	Body without
		A type Input Gear	Part Number	Part Number	B type Input Gear	Part Number	Part Number	Input Gear
RV-160	81	P50E012B00	P51J155-0		P50E012F00	P51J155A0		P50E012D00
	101	P50E013B00	P51J154-0		P50E013F00	P51J154A0		P50E013D00
	129	P50E014B00	P51J152-0		P50E014F00	P51J152A0		P50E014D00
	171	P50E015B00	P51J151-0		P50E015F00	P51J151A0		P50E015D00
	145	P50E016B00	P51J156-0		P50E016F00	P51J156A0		P50E016D00
RV-320	81	P60E012B00	P60J155-0		P60E012F00	P60J155A0		P65E012D00
	101	P60E013B00	P60J154-0		P60E013F00	P60J154A0		P65E013D00
	118.5	P60E014B00	P60J153-0		P60E014F00	P60J153A0		P65E014D00
	129	P60E015B00	P60J152-0		P60E015F00	P60J152A0		P65E015D00
	171	P60E016B00	P60J151-0		P60E016F00	P60J151A0		P65E016D00
	185	P60E017B00	P60J150-0		P60E017F00	P60J150A0		P65E017D00
	141	P60E018B00	P60J157-0		P60E018F00	P60J157A0		P65E018D00
RV-450	81	P71E011B00	P70J155-0		P71E011F00	P70J155A0		P71E011D00
	101	P71E012B00	P70J154-0		P71E012F00	P70J154A0		P71E012D00
	118.5	P71E013B00	P70J153-0		P71E013F00	P70J153A0		P71E013D00
	129	P71E014B00	P70J152-0		P71E014F00	P70J152A0		P71E014D00
	154.84	P71E015B00	P70J157-0		P71E015F00	P70J157A0		P71E015D00
	171	P71E016B00	P70J151-0		P71E016F00	P70J151A0		P71E016D00
	192.42	P71E017B00	P70J150-0		P71E017F00	P70J150A0		P71E017D00
RV-550	123	P80J013B00	P80J152-0					P80J013D00
	141	P80J014B00	P80J153-0					P80J014D00
	163.5	P80J015B00	P80J151-0					P80J015D00
	192.4	P80J016B00	P80J150-0					P80J016D00

Cautions for application of RV-E, RV-C, and RV series

- If the end user of the product is a military interest or if the product is used to manufacture weapons, the product may be subjected to export regulations prescribed in the Foreign Trade Control Act. Inspect the conditions before exporting the product and follow the necessary procedures.
- If failure or malfunction of the product directly affects people's lives or if it is used for units which may damage the human body (atomic facilities, space equipment, medical equipment, various safety units, etc.), examination is required for every application. Contact our agent or nearest business office in such a case.
- Though this product has been manufactured under strict quality control, if it is to be used for machines that could cause damage to people's lives or facilities resulting from its failure, please provide any safety means.
- When this product is used in special environment (clean room, foods, etc.), please contact our agent or your nearest business office.

Nabtesco

•In North and South America

Nabtesco Motion Control, Inc.

28850 Cabot Drive Suite 300, Novi, MI 48377, USA

Phone : 1-248-553-3020 Fax : 1-248-553-3070

E-MAIL : info@nabtescomotion.com

Home Page : www.nabtescomotion.com

•In Europe and Africa

Nabtesco Precision Europe GmbH

Klosterstraße 49, D-40211 Düsseldorf, Germany

Phone : 49-211-173790 Fax : 49-211-364677

E-MAIL : info@nabtesco-precision.de

Home Page : www.nabtesco-precision.de

•In Asia and others

Nabtesco Corporation

Tokyo Head Office

1-9-18 Kaigan Minato-ku, Tokyo 105-0022, Japan

Phone : 81-3-3578-7461 Fax : 81-3-3578-7471

E-MAIL : P_Information@nabtesco.com

Home Page : www.nabtesco.com

Tsu Plant (Engineering Department)

594 Ichimachida, Katada-cho, Tsu-shi, Mie Pref. 514-8533, Japan

Phone : 81-59-237-4602 Fax : 81-59-237-4612

Specifications in this catalog are subject to change for improvement without prior notice.