

TADIRAN BATTERIES

TECHNICAL NOTICE

The *PULSES PLUS*TM Series.

A New Battery for Applications Requiring High Current Pulses.

The Lithium Thionyl Chloride bobbin type battery technology is perfect for low current applications. It has a simple hermetic sealing construction, very low self-discharge rate (typically 1% per year) and proven shelf and operating life of over 10 years. However, its construction limits the currents that can be drawn from the battery, and therefore reduces the capability of this high energy density battery to deliver its full capacity under high load. As a solution, Tadiran now offers the Pulses Plus battery.

The Pulses PlusTM battery technology is Tadiran's unique solution for applications requiring low background currents combined with high current pulses. It combines the bobbin type Li/SOCl₂ cells with a novel hermetically sealed Hybrid Layer Capacitor (HLC).

This new battery technology can be used to deliver, efficiently, pulses up to several amperes with a voltage window between 3.9 to 3.0 V. Moreover, **this can be connected in series or in parallel to achieve higher pulses and higher voltages by combining multiple cell/HLC into battery packs.**

Tadiran's *Pulses Plus*TM battery technology, therefore, offers an unusual combination of operation advantages:

- High energy density
- High and stable operating voltage (3.67 V (standard) / 3.9 V (optional))
- High pulse current capability
- No passivation effect
- Wide operating temperature range (-40 °C to + 85 °C)
- Hermetic sealing (laser welding and Glass-to-Metal seal)
- Outstanding storage capability (up to 10 Years)
- Ultimate safety (UL)
- Very low self discharge characteristics (less than 1.5 % per year)

All these features together make it the ultimate power source for many long term (independent and stand-by) high current pulse/s applications.

Some of the applications for which this technology is being used or can be used are:

- RFID / Toll Tags Transponders
- AMR (Automatic Meter Reading) Devices
- GPS/GSM Related Systems
- Oceanographic devices
- Various Military Applications
- Location and tracking systems
- Emergency Equipment
- Medical equipment

The practical capacity and energy density of the Pulses PlusTM batteries are very high in comparison to many other types of lithium batteries.

Model: TLP-96311/A

- HIGH ENERGY
- UP TO 1A PULSE CAPABILITY
- INSTANT VOLTAGE RESPONSE

PERFORMANCE DATA @ 25 °C:

■ Capacity to 3,0 V (@ 100 mA @ 1 % duty cycle)	1,1 Ah
■ Open circuit voltage	3,67 V
■ Maximum 1 second pulse to 3,0 V	1 A
■ Diameter (max.)	17,2 mm
■ Length (max.)	48,1 mm
■ Weight (max.)	23 g
■ Capacity retention after 10 years	85 %
■ Operating temperature	-40 °C to +85 °C

Pulse curves @ 25 °C

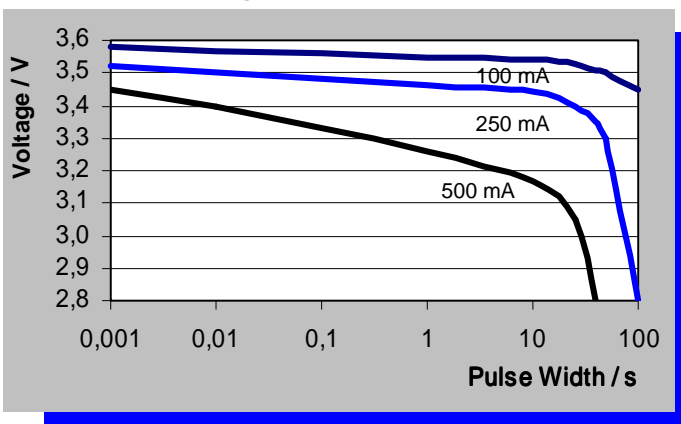

Minimum Voltage

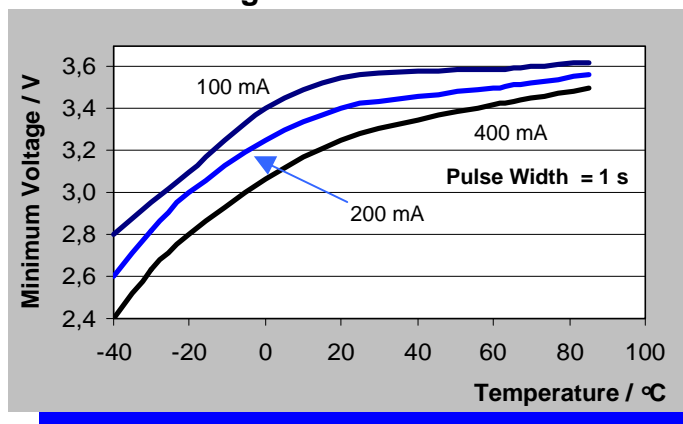

Self Discharge

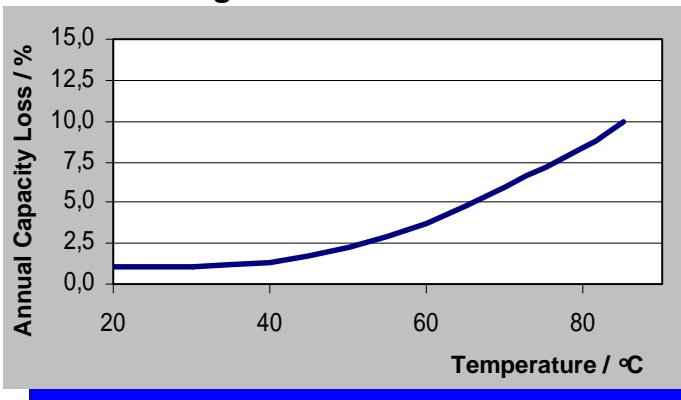

Max. Pulse Width to Min. Voltage of 3.0V at RT

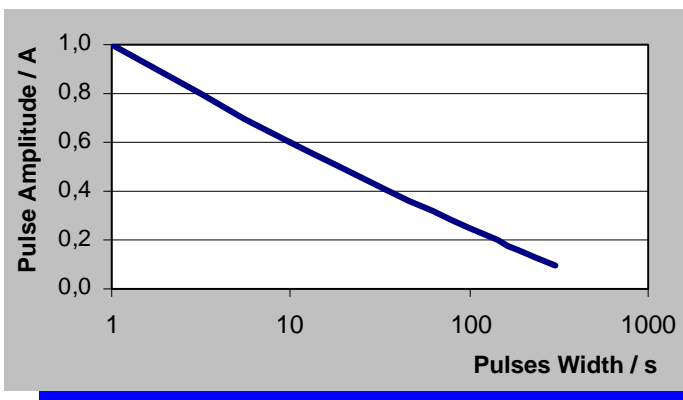

PATENTED TECHNOLOGY

Pulses Plus™ For High Pulse-Current Applications



Any values given here are for information purposes only. They also depend on actual conditions of use and are not warranties of future performance. Subject to change.

Model: TLP-96311/A

Discharge Characteristics @ 25 °C

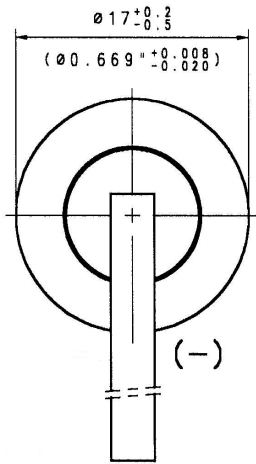
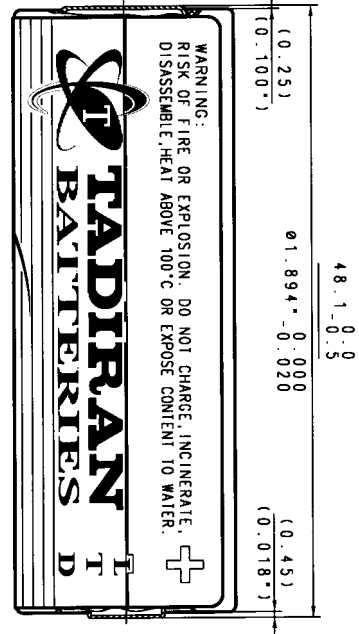
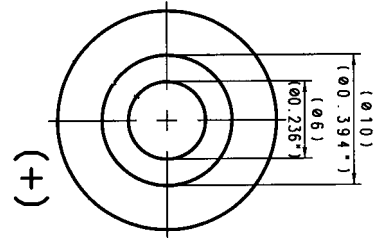
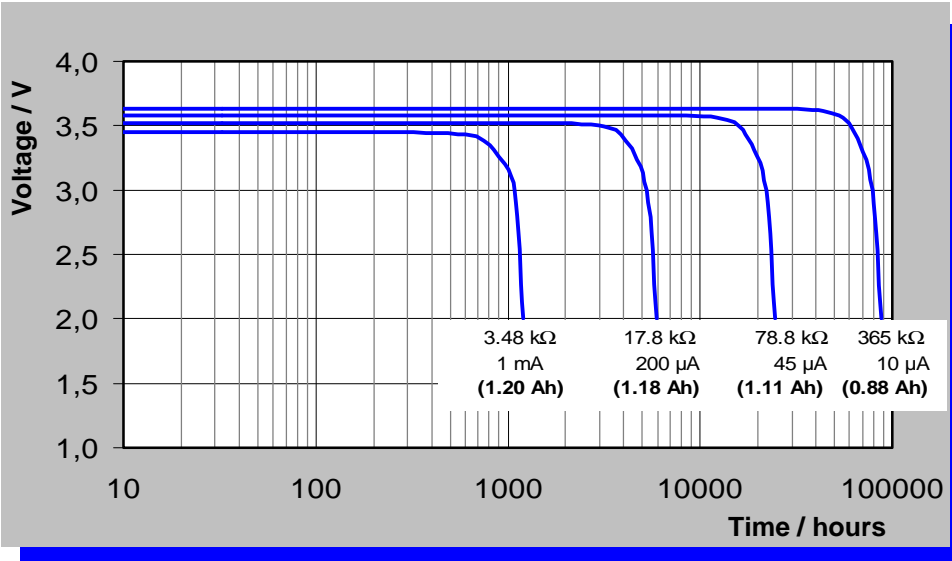

T - Terminal

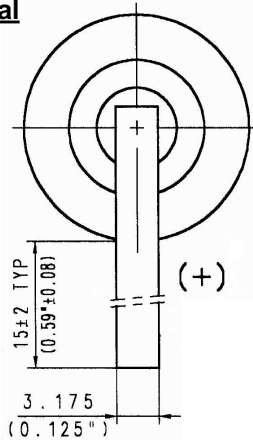

S - Terminal

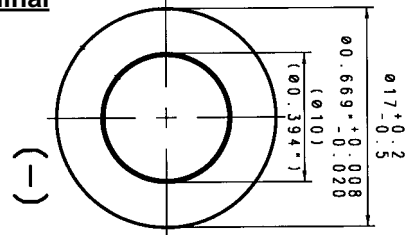

NOTE:
SPECIAL CONNECTORS ARE
AVAILABLE UPON REQUEST.

ELECTRICAL SCHEME

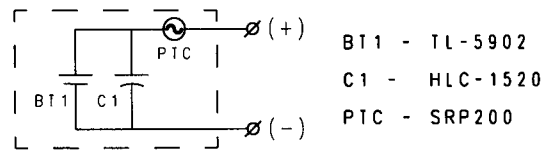

- NOTES:
- 1) OPEN CIRCUIT VOLTAGE: 3.63V TO 3.72V.
 - 2) CLOSE CIRCUIT VOLTAGE: 3.50 MIN @ 28+32Ω FOR 2 SEC.
 - 3) LABEL LETTERING SHALL INCLUDE: WARNING, TITLE, P/N & BATCH NO.

PATENTED TECHNOLOGY

Pulses Plus™ For High Pulse-Current Applications



Any values given here are for information purposes only. They also depend on actual conditions of use and are not warranties of future performance. Subject to change.

Model: TLP-97311/A

- HIGH ENERGY
- UP TO 1A PULSE CAPABILITY
- INSTANT VOLTAGE RESPONSE

PERFORMANCE DATA @ 25 °C:

■ Capacity to 3,0 V (@ 150 mA @ 1 % duty cycle)	1,6 Ah
■ Open circuit voltage	3,67 V
■ Maximum 1 second pulse to 3,0 V	1 A
■ Diameter (max.)	17,2 mm
■ Length (max.)	56,3 mm
■ Weight (max.)	26 g
■ Capacity retention after 10 years	85 %
■ Operating temperature	-40 °C to +85 °C

Pulse curves @ 25 °C

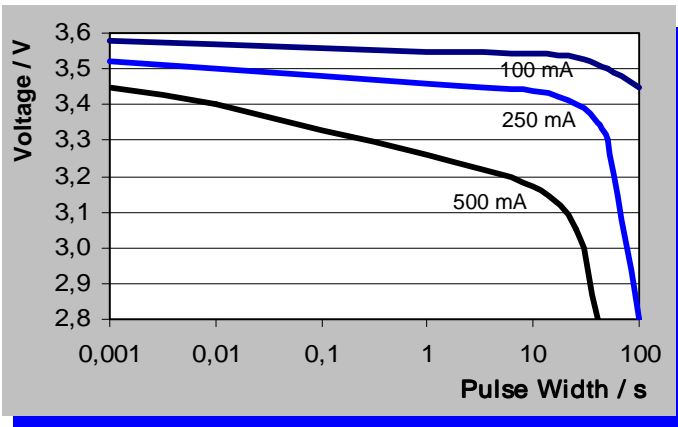

Minimum Voltage

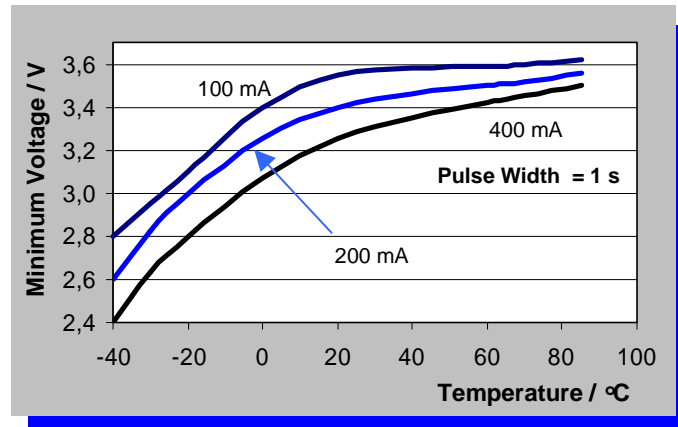

Self Discharge

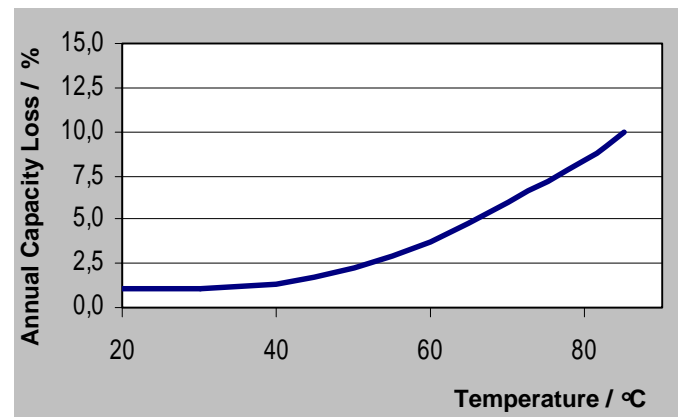

Max. Pulse Width to Min. Voltage of 3.0 V at RT

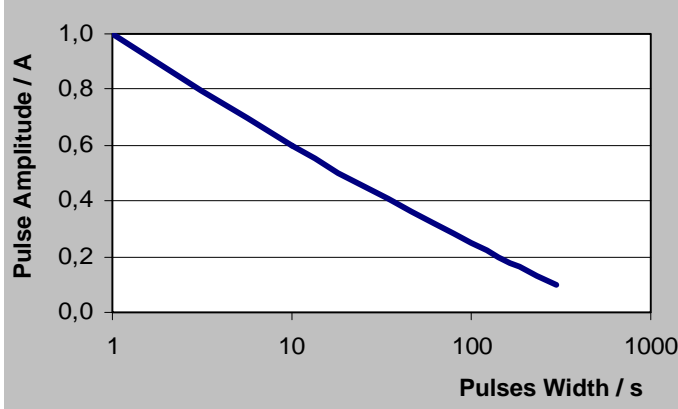

PATENTED TECHNOLOGY

Pulses Plus™ For High Pulse-Current Applications



Any values given here are for information purposes only. They also depend on actual conditions of use and are not warranties of future performance. Subject to change.

Model: TLP-97311/A

Discharge Characteristics @ 25 °C

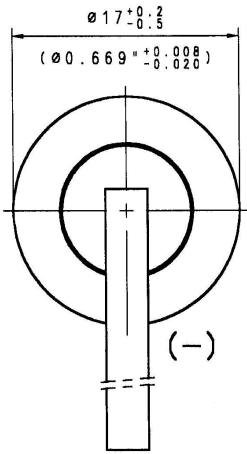
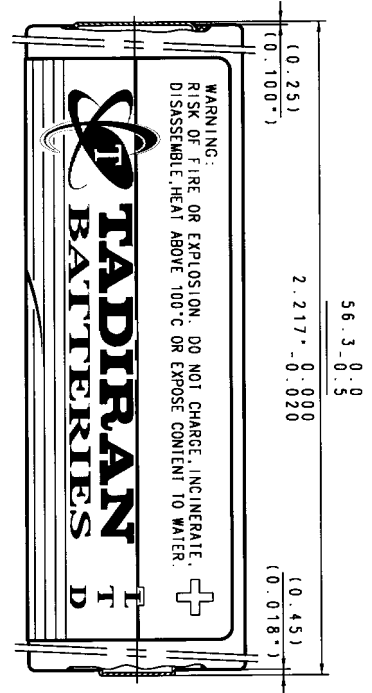
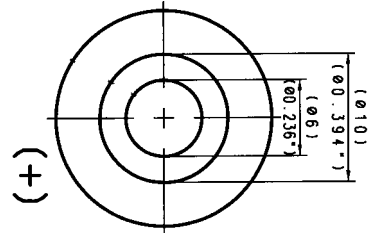
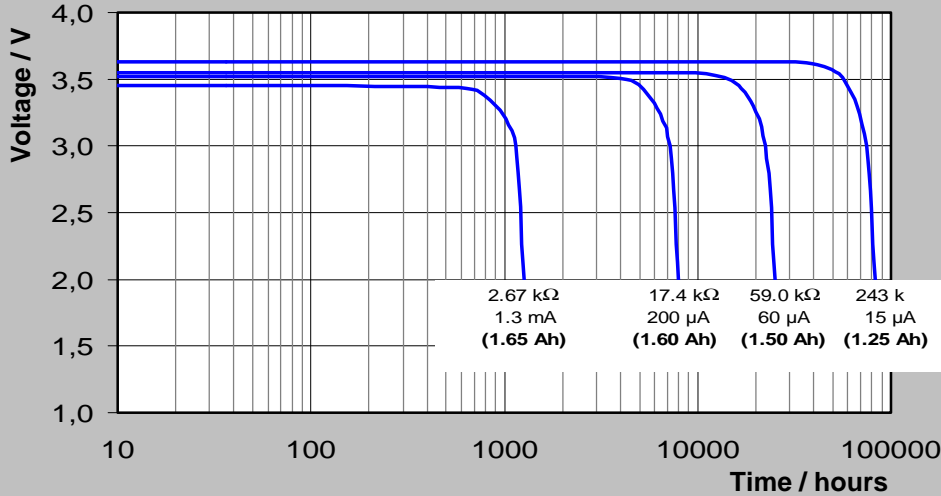

T - Terminal

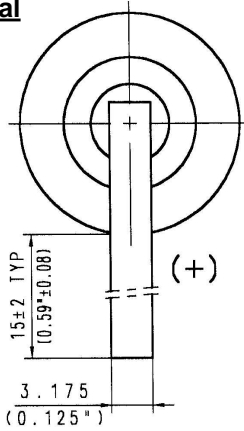

S - Terminal

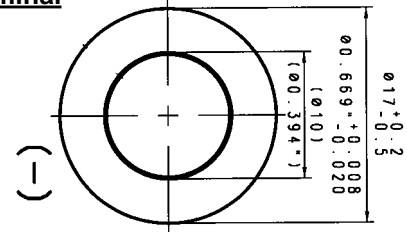

NOTE:
SPECIAL CONNECTORS ARE
AVAILABLE UPON REQUEST.

ELECTRICAL SCHEME

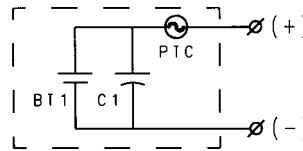

BT1 - 1L-5955
C1 - HLC-1520
PTC - SRP200

NOTES:

- 1) OPEN CIRCUIT VOLTAGE: 3.63V TO 3.72V.
- 2) CLOSE CIRCUIT VOLTAGE: 3.50 MIN @ 28+32Ω FOR 2 SEC.
- 3) LABEL LETTERING SHALL INCLUDE: TITLE, NOMINAL VOLTAGE & BATCH N

PATENTED TECHNOLOGY

Pulses Plus™ For High Pulse-Current Applications



Any values given here are for information purposes only. They also depend on actual conditions of use and are not warranties of future performance. Subject to change.

Model: TLP-91311/A

- HIGH ENERGY
- UP TO 1A PULSE CAPABILITY
- INSTANT VOLTAGE RESPONSE

PERFORMANCE DATA @ 25 °C:

■ Capacity to 3,0 V (@ 250 mA @ 1 % duty cycle)	2,4 Ah
■ Open circuit voltage	3,67 V
■ Maximum 1 second pulse to 3,0 V	1 A
■ Diameter (max.)	17,2 mm
■ Length (max.)	73,0 mm
■ Weight (max.)	32 g
■ Capacity retention after 10 years	85 %
■ Operating temperature	-40 °C to +85 °C

Pulse curves @ 25 °C

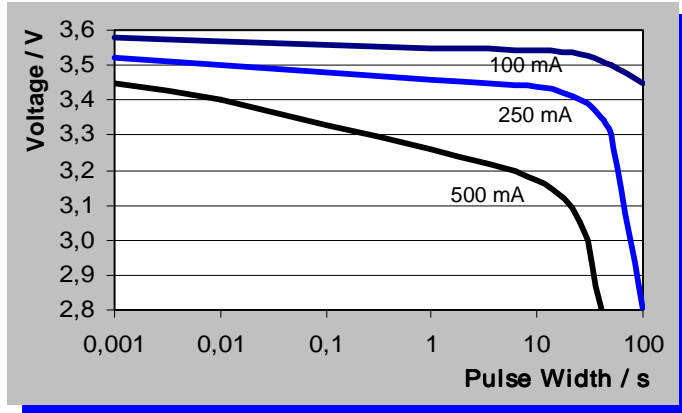

Minimum Voltage

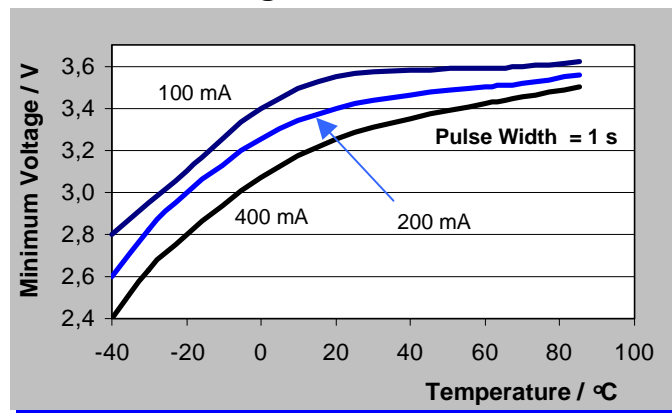

Self Discharge

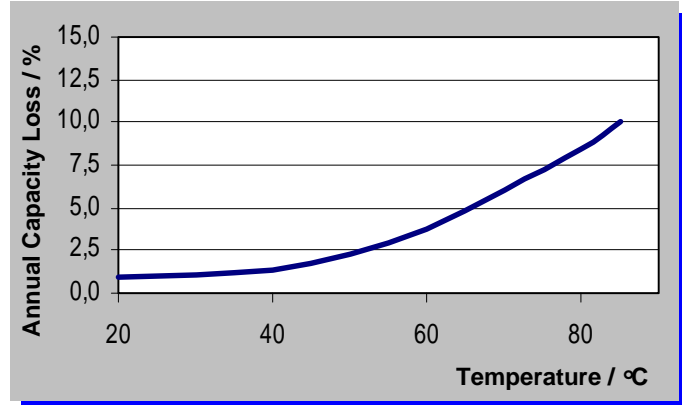

Max. Pulse Width to Min. Voltage of 3.0V at RT

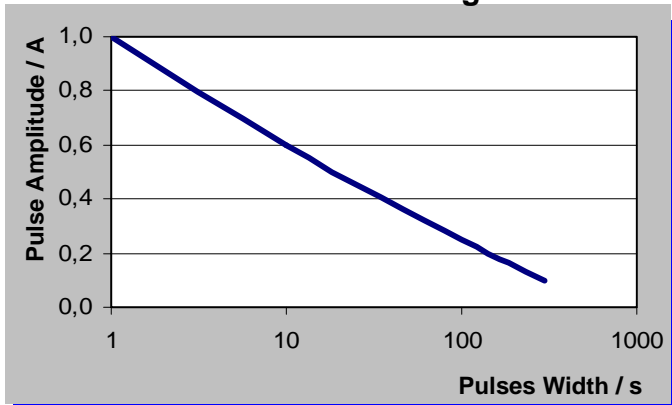

PATENTED TECHNOLOGY

Pulses Plus™ For High Pulse-Current Applications



Any values given here are for information purposes only. They also depend on actual conditions of use and are not warranties of future performance. Subject to change.

Model: TLP-91311/A

Discharge Characteristics @ 25 °C

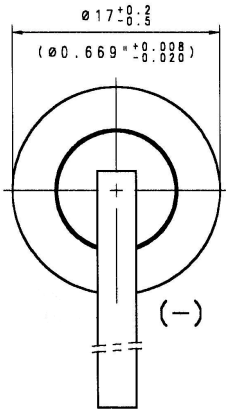
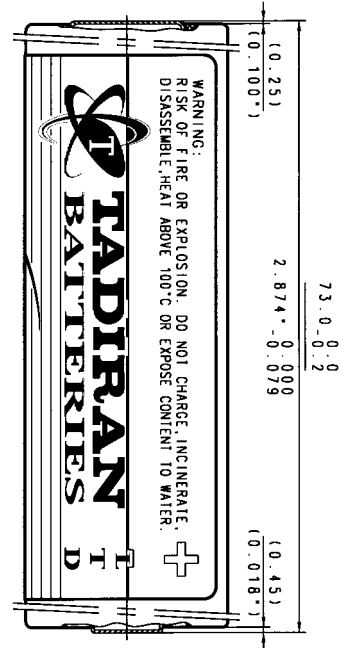
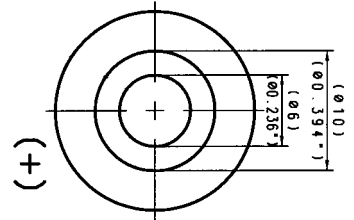
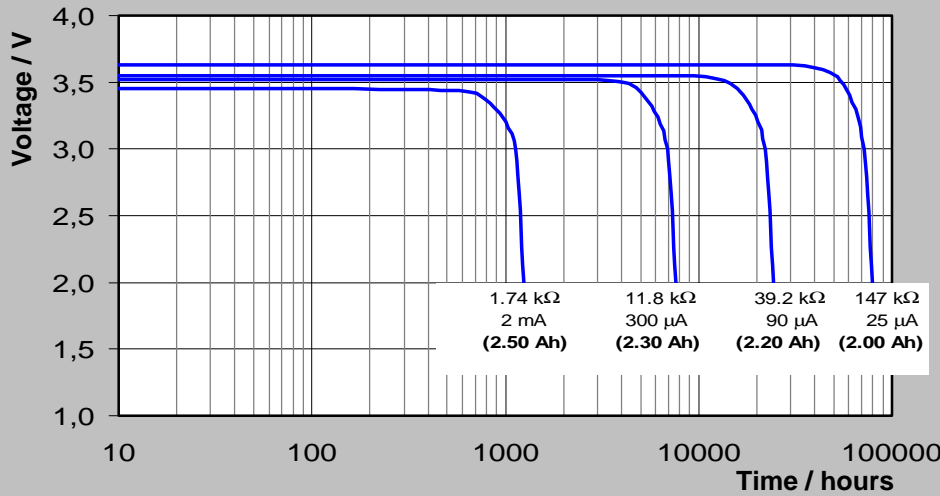

T - Terminal

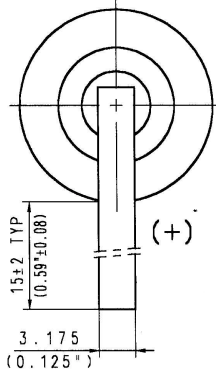

S - Terminal

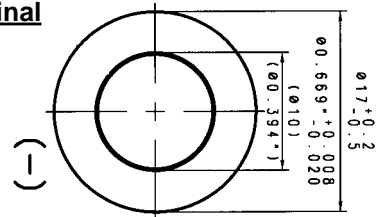

NOTE:
SPECIAL CONNECTORS ARE
AVAILABLE UPON REQUEST.

ELECTRICAL SCHEME

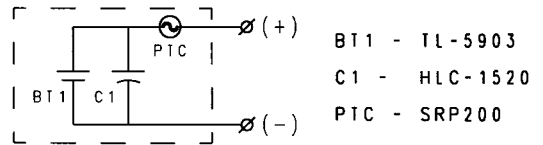

NOTES:

- 1) OPEN CIRCUIT VOLTAGE: 3.63V TO 3.72V.
- 2) CLOSE CIRCUIT VOLTAGE: 3.50 MIN @ 28+32Ω FOR 2 SEC.
- 3) LABEL LETTERING SHALL INCLUDE: TITLE, NOMINAL VOLTAGE & BATCH NO.

PATENTED TECHNOLOGY

Pulses Plus™ For High Pulse-Current Applications



Any values given here are for information purposes only. They also depend on actual conditions of use and are not warranties of future performance. Subject to change.

Model: TLP-92311/A

- HIGH ENERGY
- UP TO 1A PULSE CAPABILITY
- INSTANT VOLTAGE RESPONSE

PERFORMANCE DATA @ 25 °C:

■ Capacity to 3,0 V (@ 250 mA @ 1 % duty cycle)	8,5 Ah
■ Open circuit voltage	3,67 V
■ Maximum 1 second pulse to 3,0 V	1 A
■ Diameter (max.)	28,2 mm
■ Length (max.)	69,5 mm
■ Weight (max.)	75 g
■ Capacity retention after 10 years	85 %
■ Operating temperature	-40 °C to +85 °C

Pulse curves @ 25 °C

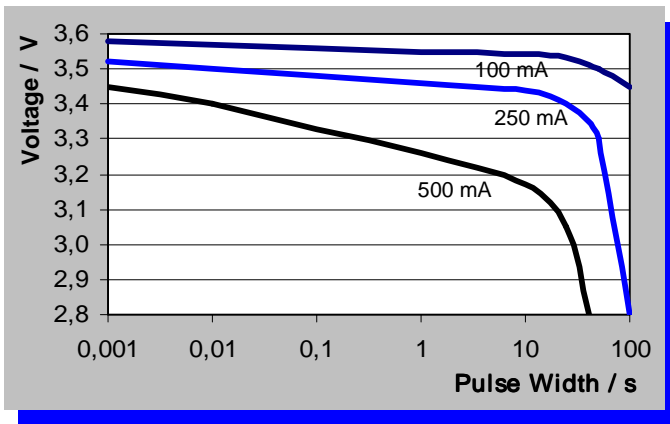

Minimum Voltage

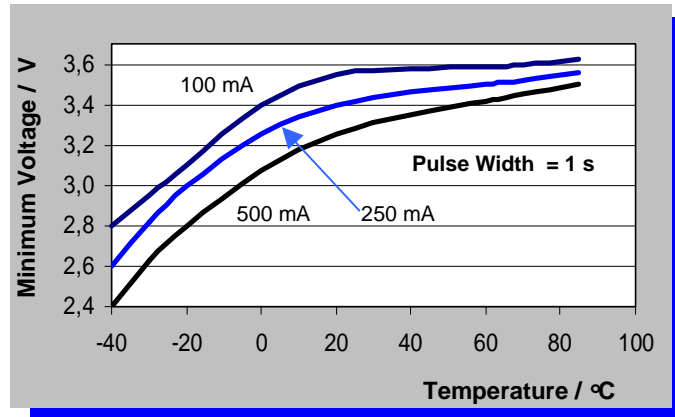

Self Discharge

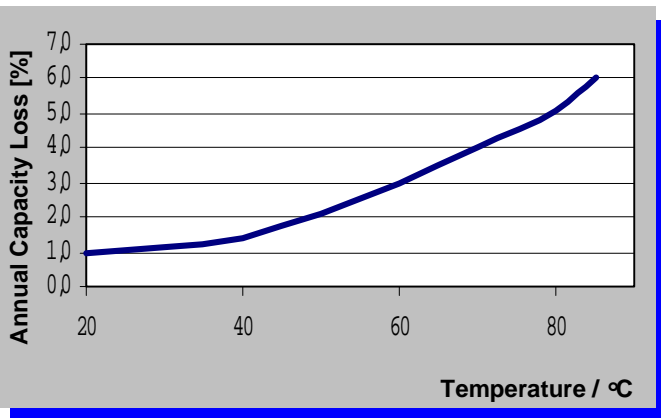

Max. Pulse Width to Min. Voltage of 3.0V at RT

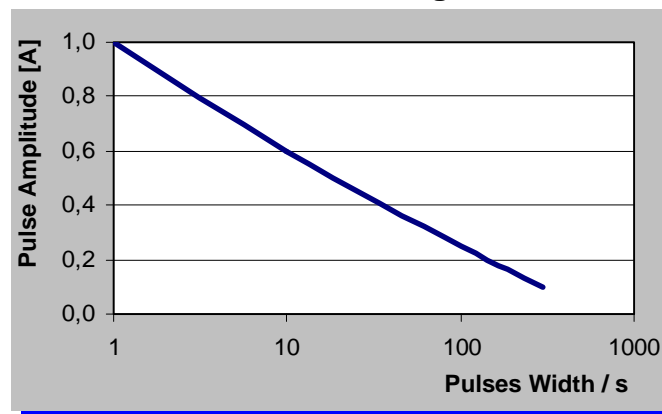

PATENTED TECHNOLOGY

Pulses Plus™ For High Pulse-Current Applications



Any values given here are for information purposes only. They also depend on actual conditions of use and are not warranties of future performance. Subject to change.

Model: TLP-92311/A

Discharge Characteristics @ 25 °C

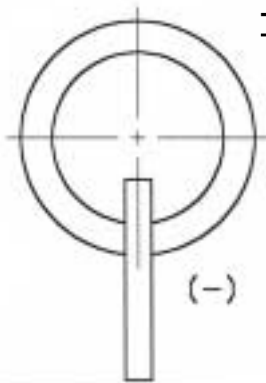
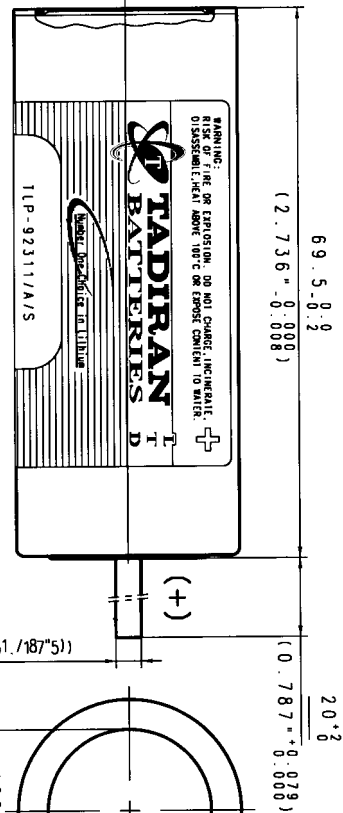
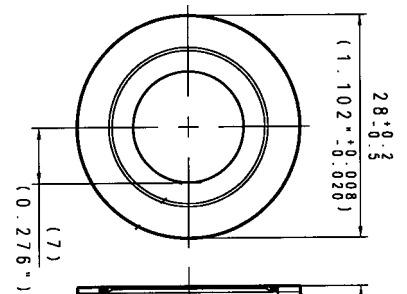
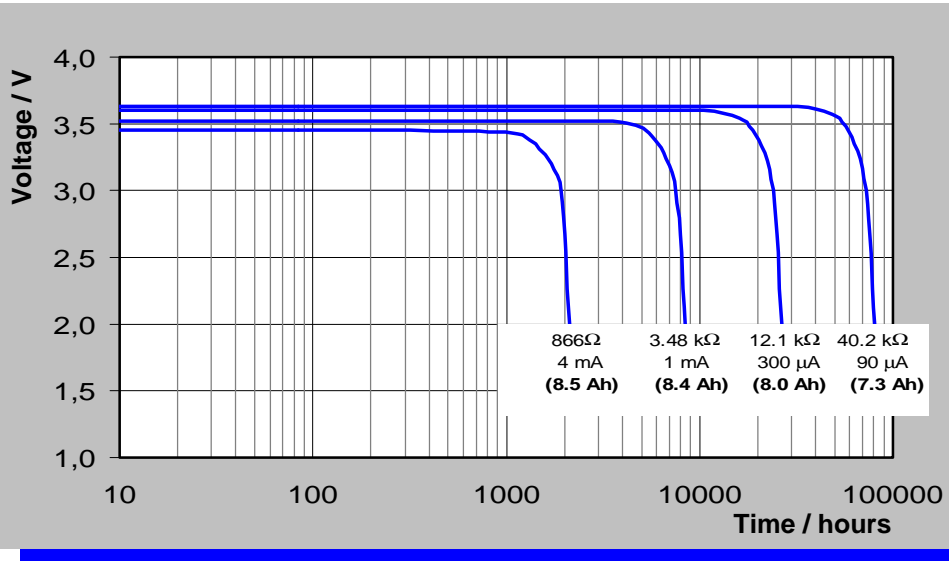

T - Terminal

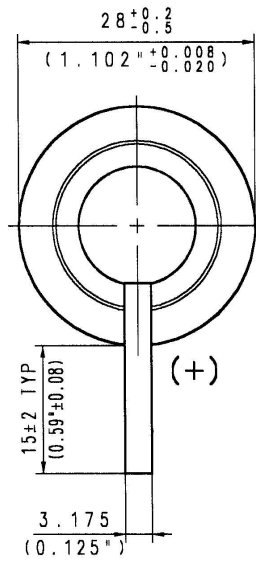

S - Terminal

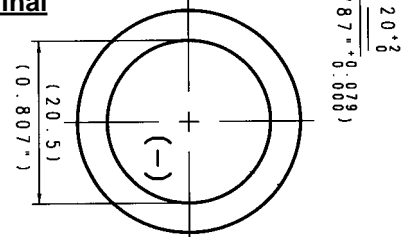

NOTE:
SPECIAL CONNECTORS ARE
AVAILABLE UPON REQUEST.

ELECTRICAL SCHEME

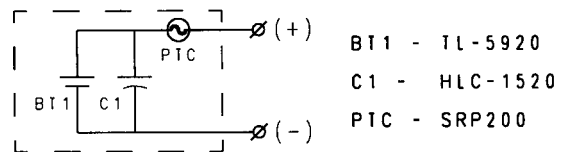

NOTES:

- 1) OPEN CIRCUIT VOLTAGE: 3.63V TO 3.72V.
- 2) CLOSE CIRCUIT VOLTAGE: 3.50 MIN @ 28±32Ω FOR 2 SEC.
- 3) LABEL LETTERING SHALL INCLUDE: TITLE, NOMINAL VOLTAGE & BATCH NO.

PATENTED TECHNOLOGY

Pulses Plus™ For High Pulse-Current Applications



Any values given here are for information purposes only. They also depend on actual conditions of use and are not warranties of future performance. Subject to change.

Model: TLP-93311/A

- HIGH ENERGY
- UP TO 1A PULSE CAPABILITY
- INSTANT VOLTAGE RESPONSE

PERFORMANCE DATA @ 25 °C:

■ Capacity to 3,0 V (@ 250 mA @ 1 % duty cycle)	19,0 Ah
■ Open circuit voltage	3,67 V
■ Maximum 1 second pulse to 3,0 V	1 A
■ Diameter (max.)	35,2 mm
■ Length (max.)	80,2 mm
■ Weight (max.)	120 g
■ Capacity retention after 10 years	85 %
■ Operating temperature	-40 °C to +85 °C

Pulse curves @ 25 °C

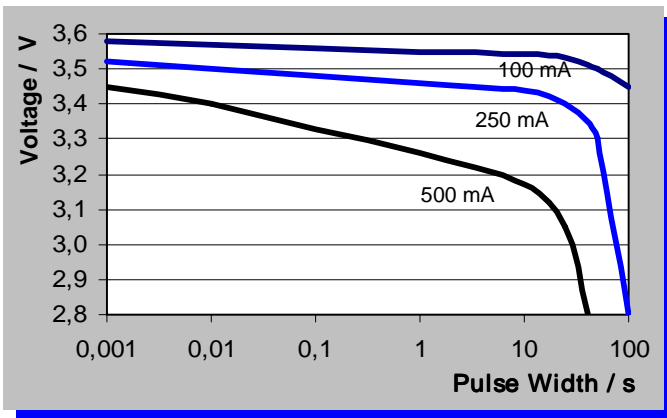

Minimum Voltage

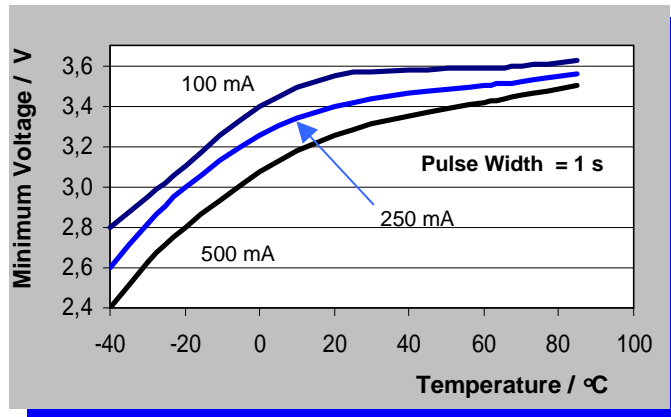

Self Discharge

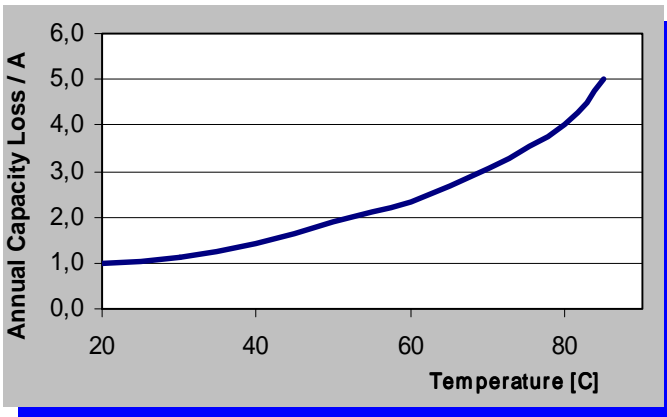

Max. Pulse Width to Min. Voltage of 3.0V at RT

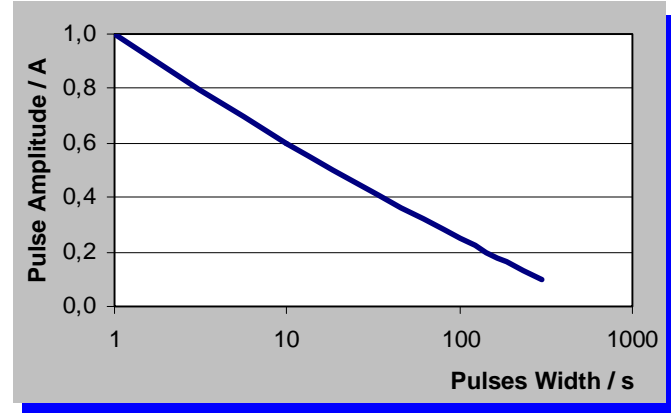

PATENTED TECHNOLOGY

Pulses Plus™ For High Pulse-Current Applications



Any values given here are for information purposes only. They also depend on actual conditions of use and are not warranties of future performance. Subject to change.

Model: TLP-93311/A

Discharge Characteristics @ 25 °C

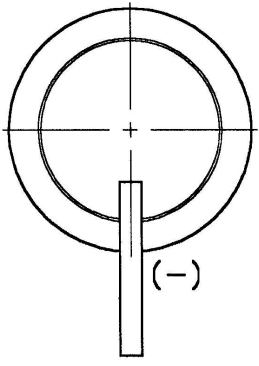
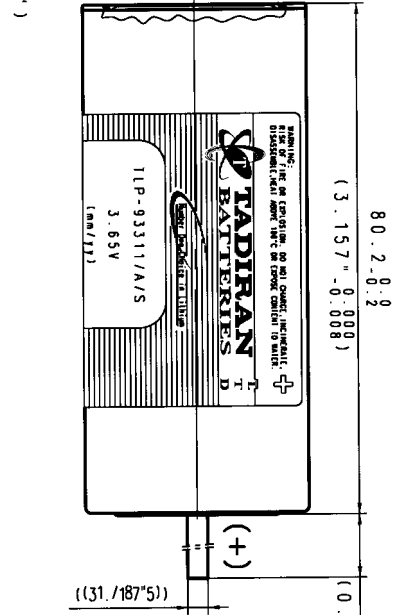
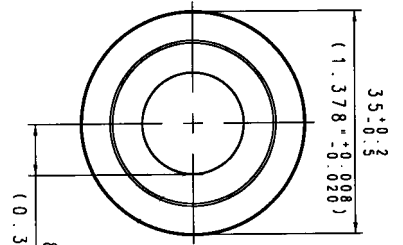
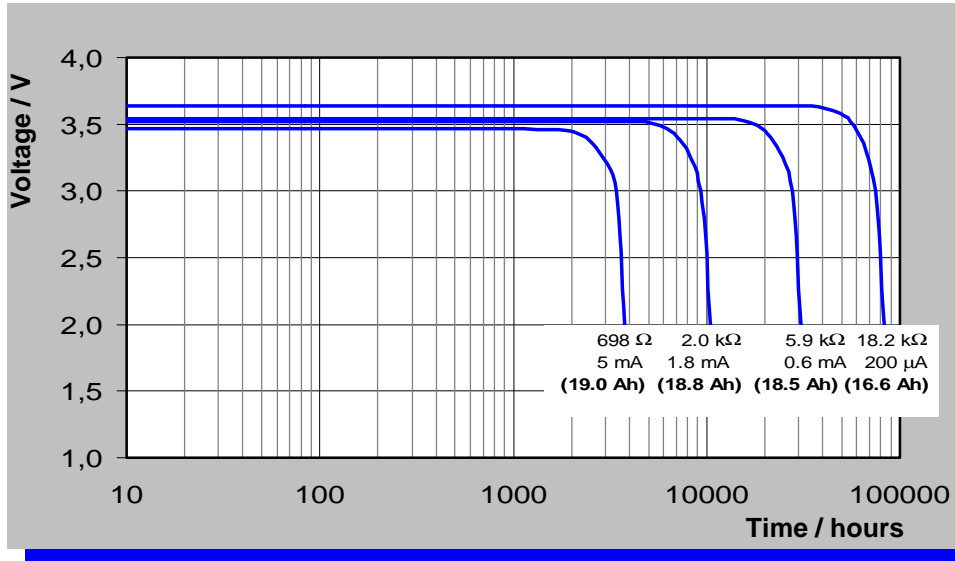

T - Terminal

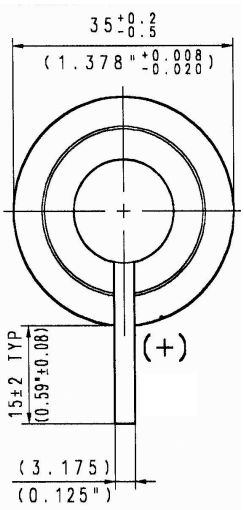

S - Terminal

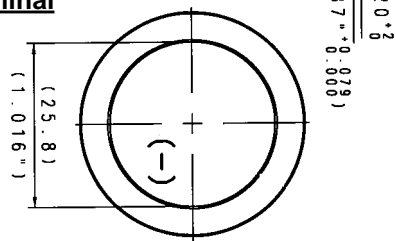

NOTE:
SPECIAL CONNECTORS ARE
AVAILABLE UPON REQUEST.

ELECTRICAL SCHEME

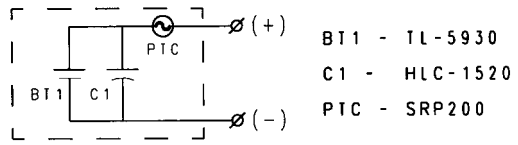

- NOTES:
- 1) OPEN CIRCUIT VOLTAGE: 3.63V TO 3.72V.
 - 2) CLOSE CIRCUIT VOLTAGE: 3.50 MIN @ 28±32R FOR 2 SEC.
 - 3) LABEL LETTERING SHALL INCLUDE: TITLE, NOMINAL VOLTAGE & BATCH NO.

PATENTED TECHNOLOGY

Pulses Plus™ For High Pulse-Current Applications



Any values given here are for information purposes only. They also depend on actual conditions of use and are not warranties of future performance. Subject to change.

Model: TLP-96111/A

- HIGH ENERGY
- UP TO 3A PULSE CAPABILITY
- INSTANT VOLTAGE RESPONSE

PERFORMANCE DATA @ 25°C:

■ Capacity to 3,0 V (@ 100 mA @ 1 % duty cycle)	1,1 Ah
■ Open circuit voltage	3,67 V
■ Maximum 1 second pulse to 3,0 V	3 A
■ Weight	37 g
■ Capacity retention after 10 years	85 %
■ Operating temperature	-40 °C to +85 °C

Pulse curves @ 25 °C

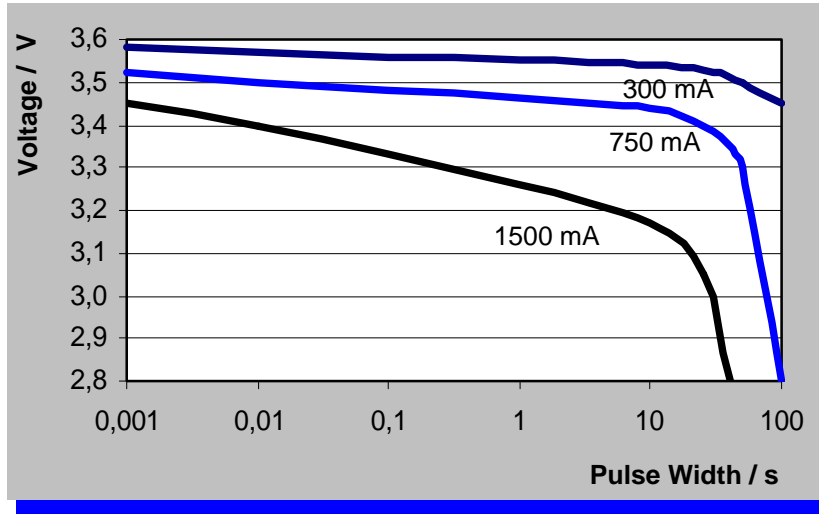

Discharge Characteristics @ 25 °C

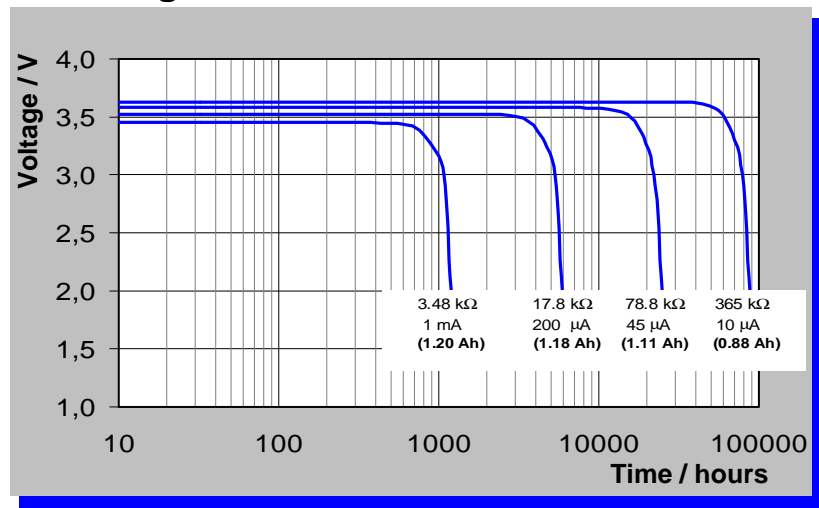

PATENTED TECHNOLOGY

Pulses Plus™ For High Pulse-Current Applications



Any values given here are for information purposes only. They also depend on actual conditions of use and are not warranties of future performance. Subject to change.

Minimum Voltage

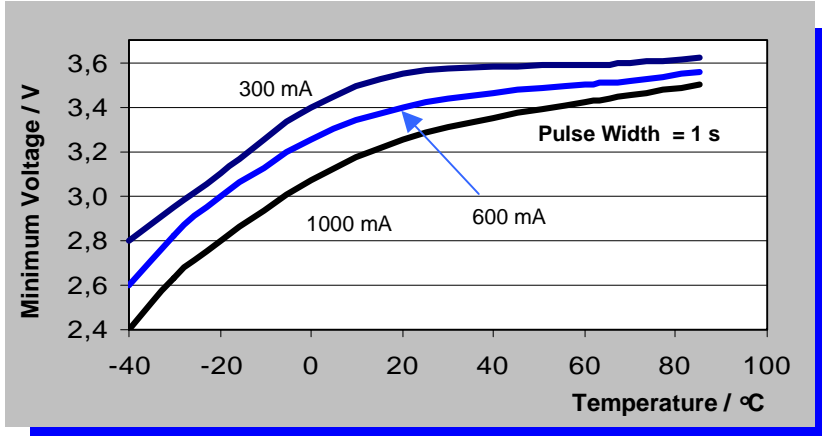

TLP-96111/A

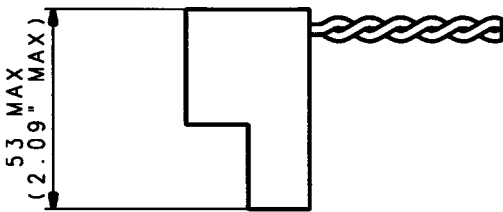

Self Discharge

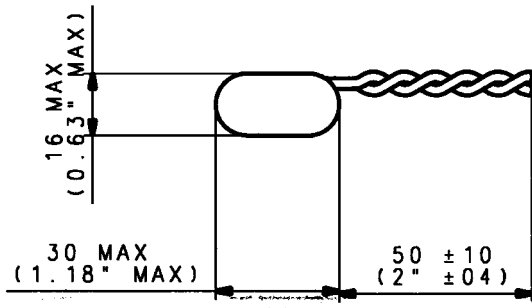
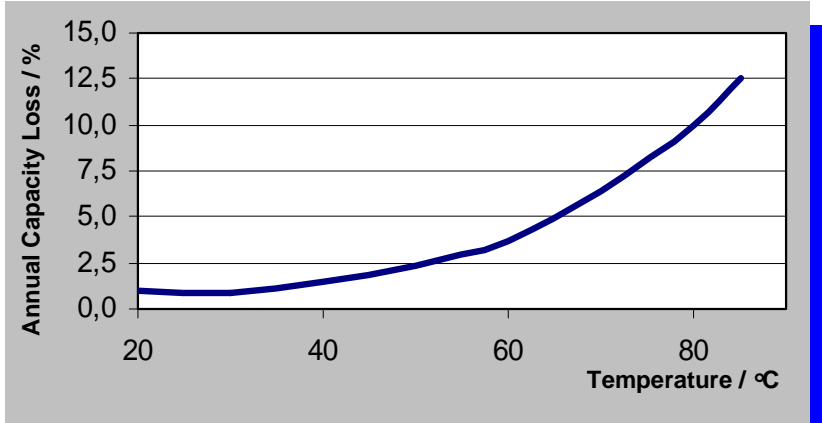

Maximum Pulse Width to Min. Voltage of 3.0 V at RT

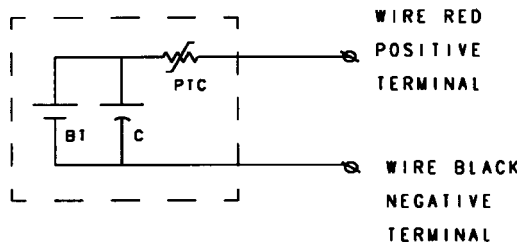
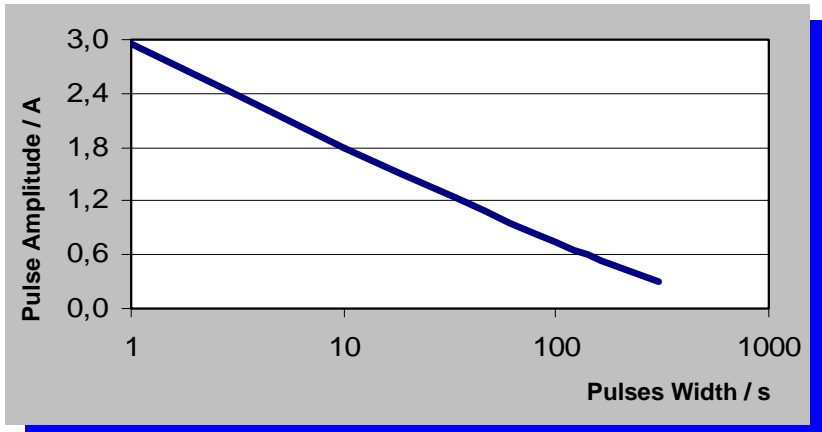

- BT: TL-5902
- C: HLC-1550
- PTC: SRP 200

NOTE:
SPECIAL CONNECTORS ARE
AVAILABLE UPON REQUEST.

PATENTED TECHNOLOGY

Pulses Plus™ For High Pulse-Current Applications



Any values given here are for information purposes only. They also depend on actual conditions of use and are not warranties of future performance. Subject to change.

Model: TLP-97111/A

- HIGH ENERGY
- UP TO 3A PULSE CAPABILITY
- INSTANT VOLTAGE RESPONSE

PERFORMANCE DATA @ 25°C:

■ Capacity to 3,0 V (@ 150 mA @ 1% duty cycle)	1,6 Ah
■ Open circuit voltage	3,67 V
■ Maximum 1 second pulse to 3,0 V	3 A
■ Weight	39 g
■ Capacity retention after 10 years	85 %
■ Operating temperature	-40 °C to +85 °C

Pulse curves @ 25 °C

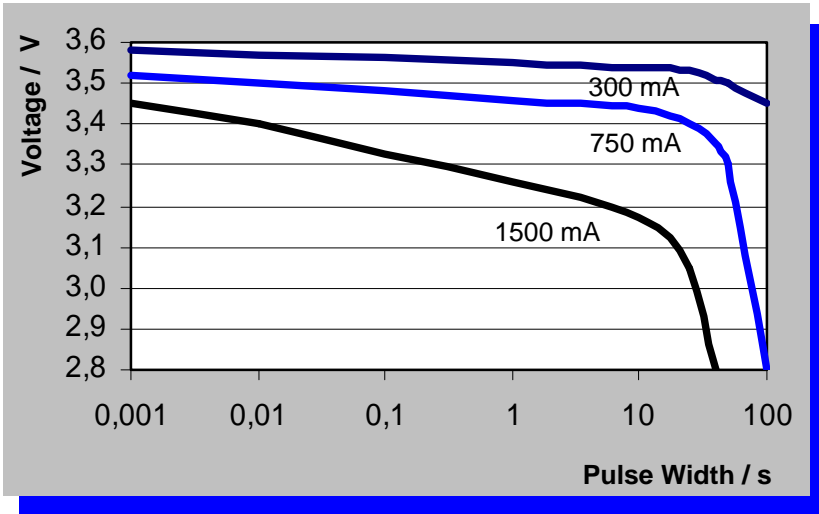

Discharge Characteristics @ 25 °C

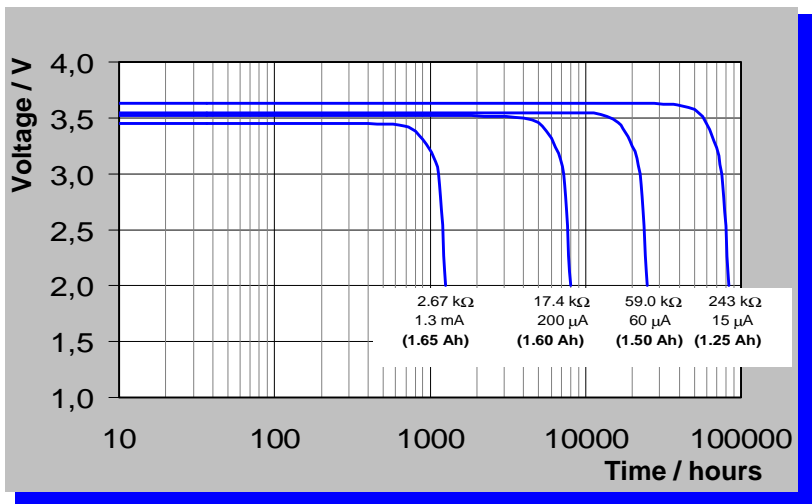

PATENTED TECHNOLOGY

Pulses Plus™ For High Pulse-Current Applications



Any values given here are for information purposes only. They also depend on actual conditions of use and are not warranties of future performance. Subject to change.

Minimum Voltage

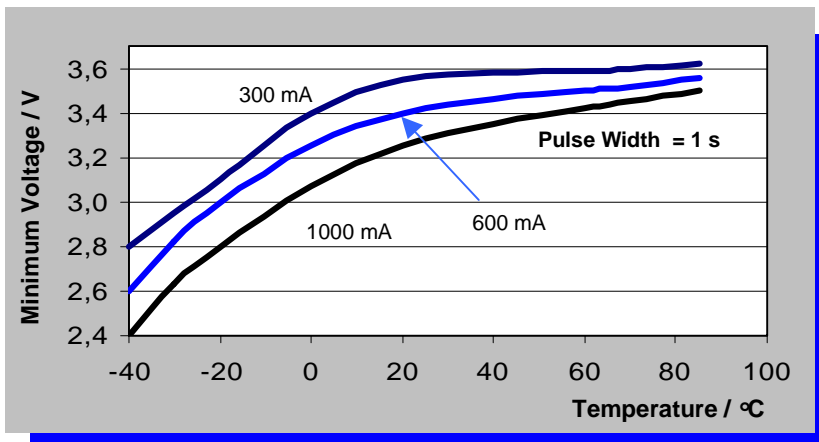

TLP-97111/A

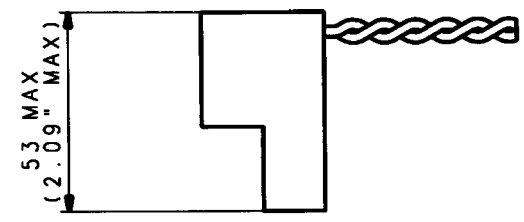

Self Discharge

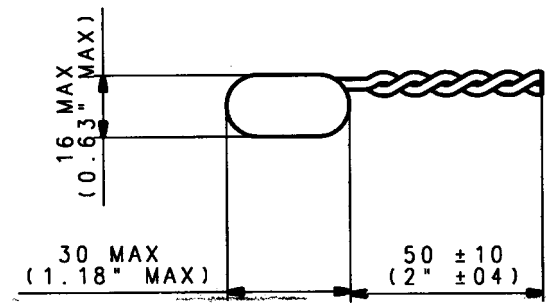
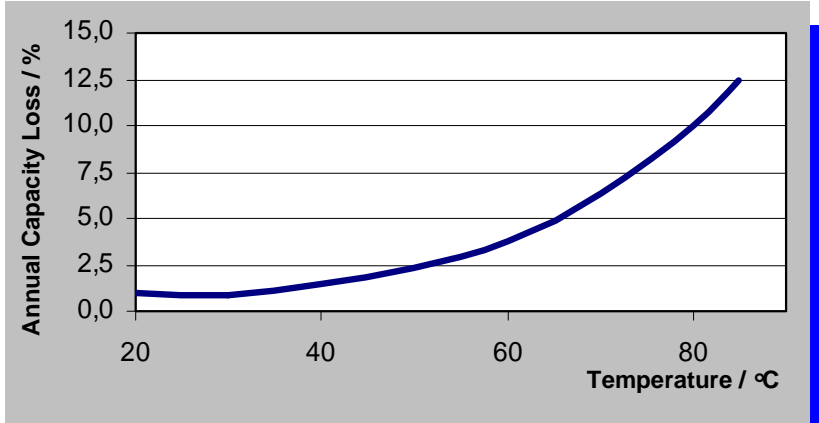

Maximum Pulse Width to Min. Voltage of 3.0 V at RT

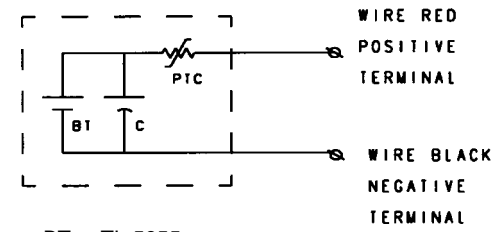
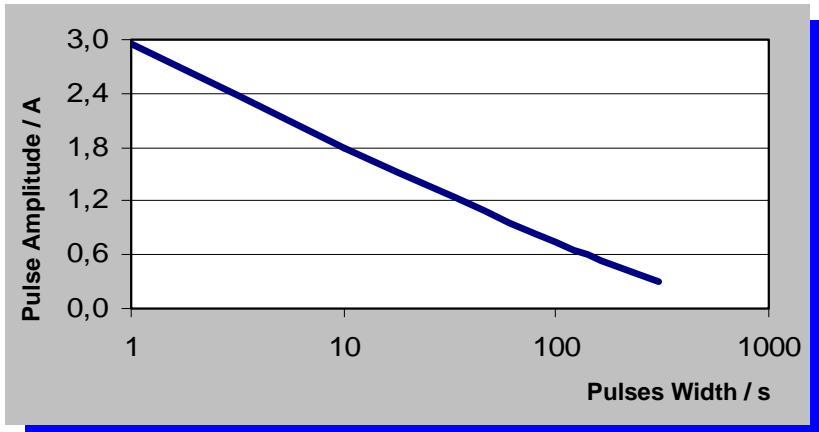

BT: TL-5955
 C: HLC-1550
 PTC: SRP 200

NOTE:
 SPECIAL CONNECTORS ARE
 AVAILABLE UPON REQUEST.

PATENTED TECHNOLOGY

Pulses Plus™ For High Pulse-Current Applications



Any values given here are for information purposes only. They also depend on actual conditions of use and are not warranties of future performance. Subject to change.

Model: TLP-91111/A

- HIGH ENERGY
- UP TO 3A PULSE CAPABILITY
- INSTANT VOLTAGE RESPONSE

PERFORMANCE DATA @ 25°C:

■ Capacity to 3,0 V (@ 250 mA @ 1% duty cycle)	2,4 Ah
■ Open circuit voltage	3,67 V
■ Maximum 1 second pulse to 3,0 V	3 A
■ Weight	43 g
■ Capacity retention after 10 years	85 %
■ Operating temperature	-40 °C to +85 °C

Pulse curves @ 25 °C

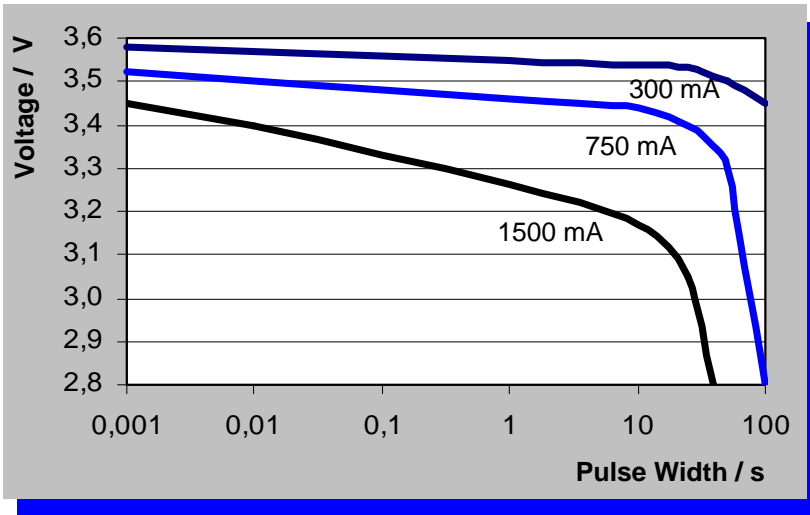

Discharge Characteristics @ 25 °C

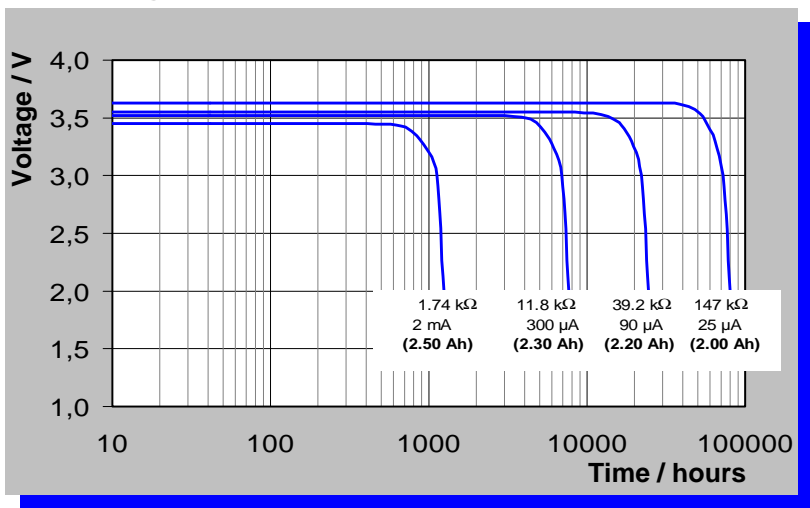

PATENTED TECHNOLOGY

Pulses Plus™ For High Pulse-Current Applications



Any values given here are for information purposes only. They also depend on actual conditions of use and are not warranties of future performance. Subject to change.

Minimum Voltage

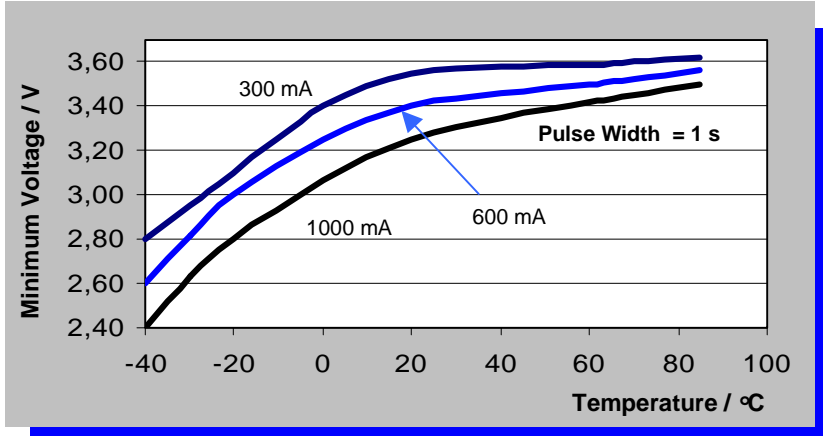

TLP-91111/A

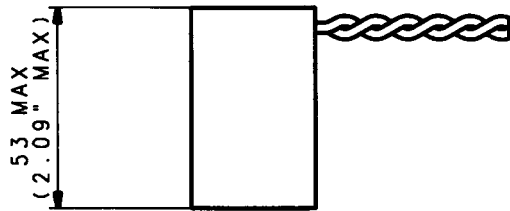

Self Discharge

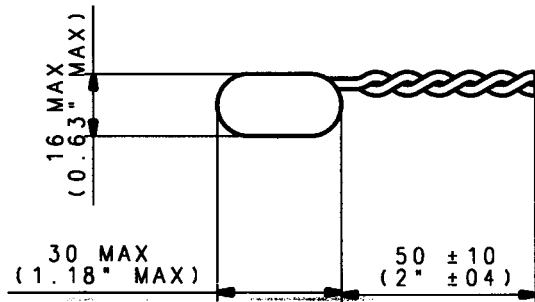
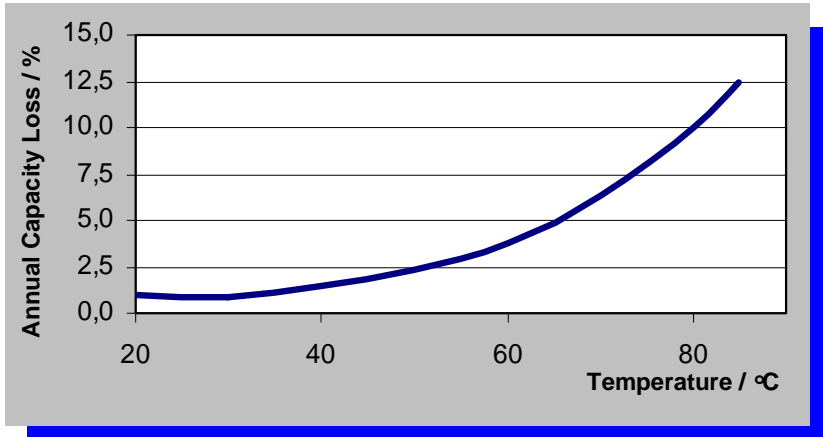

Maximum Pulse Width to Min. Voltage of 3.0 V at RT

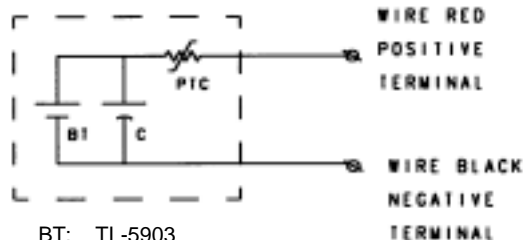
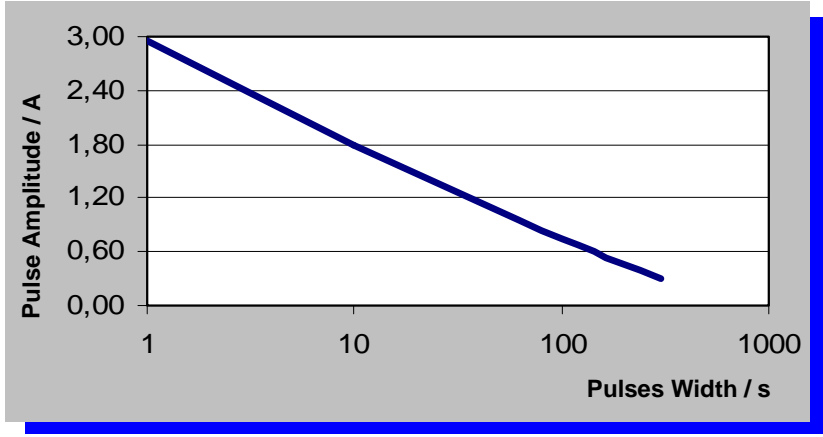

BT: TL-5903
 C: HLC-1550
 PTC: SRP 200

NOTE:
 SPECIAL CONNECTORS ARE
 AVAILABLE UPON REQUEST.

PATENTED TECHNOLOGY

Pulses Plus™ For High Pulse-Current Applications



Any values given here are for information purposes only. They also depend on actual conditions of use and are not warranties of future performance. Subject to change.

Model: TLP-92111/A

- HIGH ENERGY
- UP TO 3A PULSE CAPABILITY
- INSTANT VOLTAGE RESPONSE

PERFORMANCE DATA @ 25°C:

■ Capacity to 3,0 V (@ 250 mA @ 1% duty cycle)	8,5 Ah
■ Open circuit voltage	3,67 V
■ Maximum 1 second pulse to 3,0 V	3 A
■ Weight	77 g
■ Capacity retention after 10 years	85 %
■ Operating temperature	-40 °C to +85 °C

Pulse curves @ 25 °C

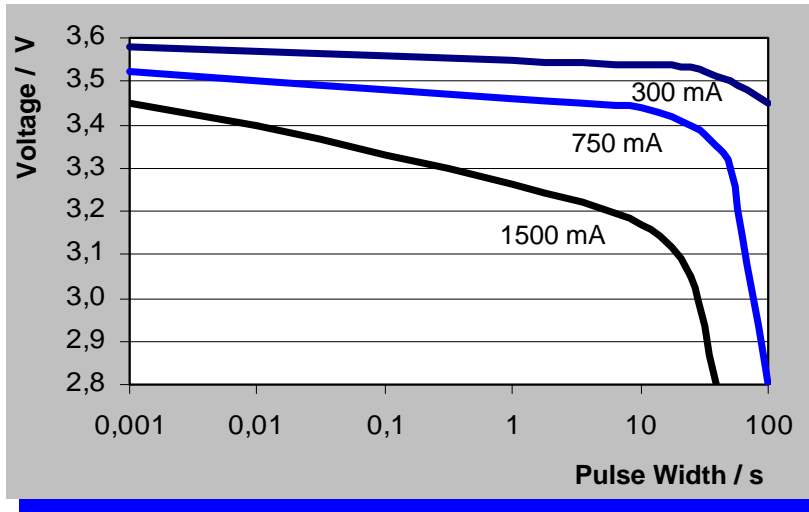

Discharge Characteristics @ 25 °C

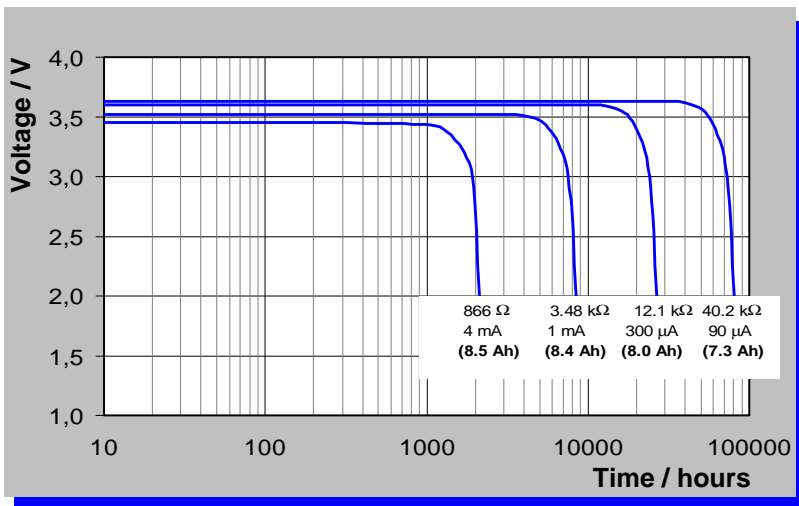

PATENTED TECHNOLOGY

Pulses Plus™ For High Pulse-Current Applications



Any values given here are for information purposes only. They also depend on actual conditions of use and are not warranties of future performance. Subject to change.

Minimum Voltage

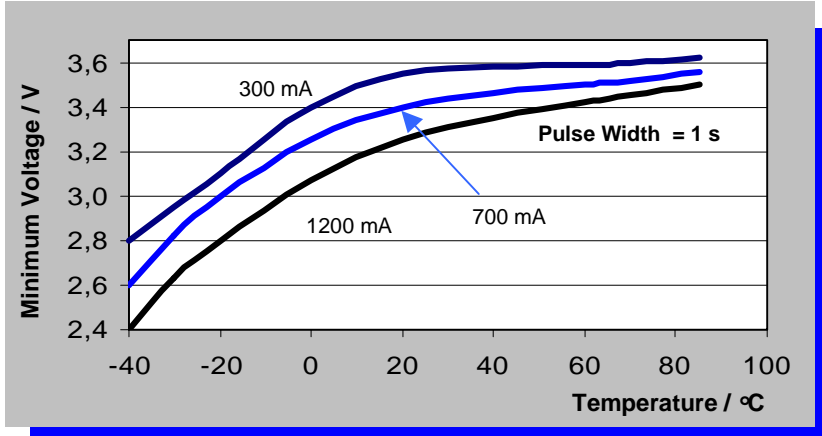

TLP-92111/A

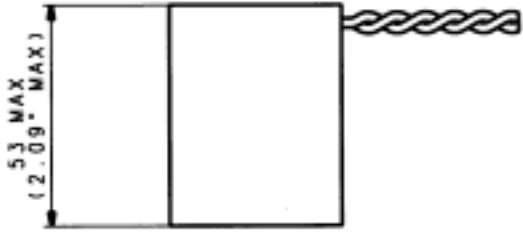

Self Discharge

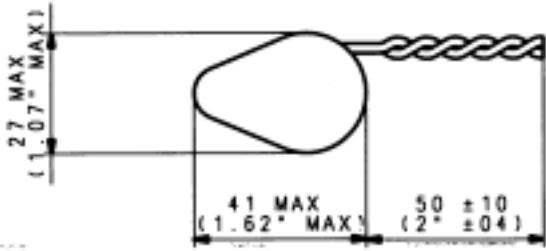
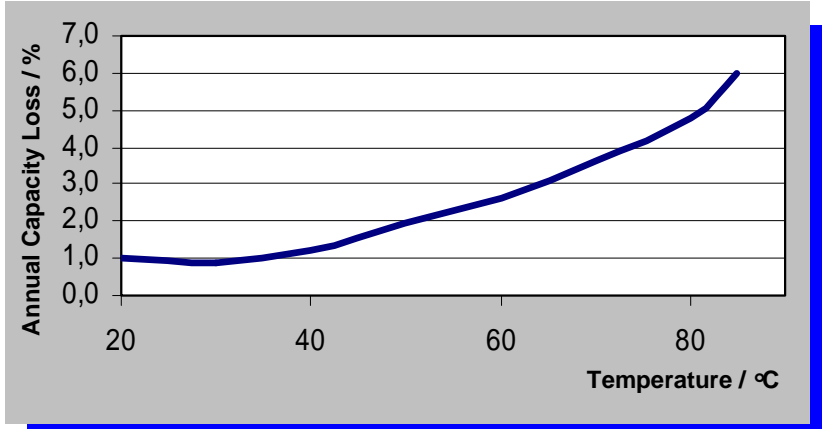

Maximum Pulse Width to Min. Voltage of 3.0 V at RT

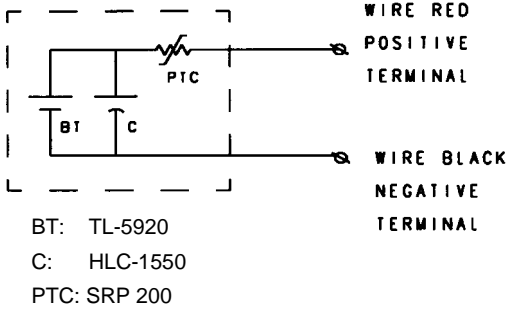
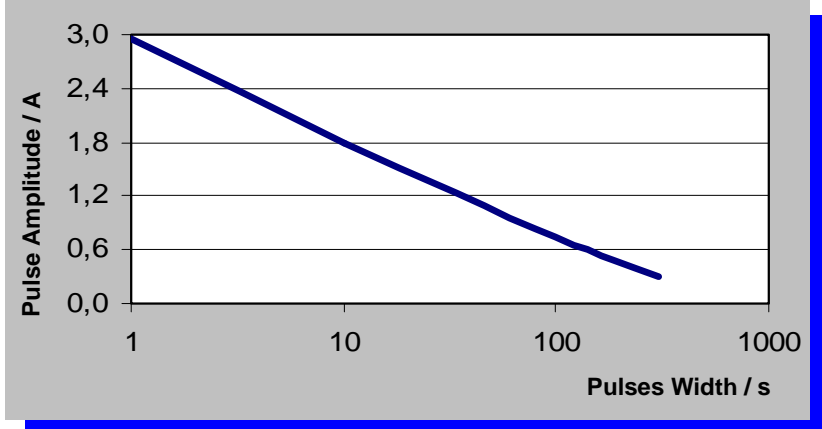

NOTE:
 SPECIAL CONNECTORS ARE
 AVAILABLE UPON REQUEST.

PATENTED TECHNOLOGY

Any values given here are for information purposes only. They also depend on actual conditions of use and are not warranties of future performance. Subject to change.

Model: TLP-93111/A

- HIGH ENERGY
- UP TO 3A PULSE CAPABILITY
- INSTANT VOLTAGE RESPONSE

PERFORMANCE DATA @ 25°C:

■ Capacity to 3,0 V (@ 250 mA @ 1% duty cycle)	19,0 Ah
■ Open circuit voltage	3,67 V
■ Maximum 1 second pulse to 3,0 V	3 A
■ Weight	116 g
■ Capacity retention after 10 years	85 %
■ Operating temperature	-40 °C to +85 °C

Pulse curves @ 25 °C

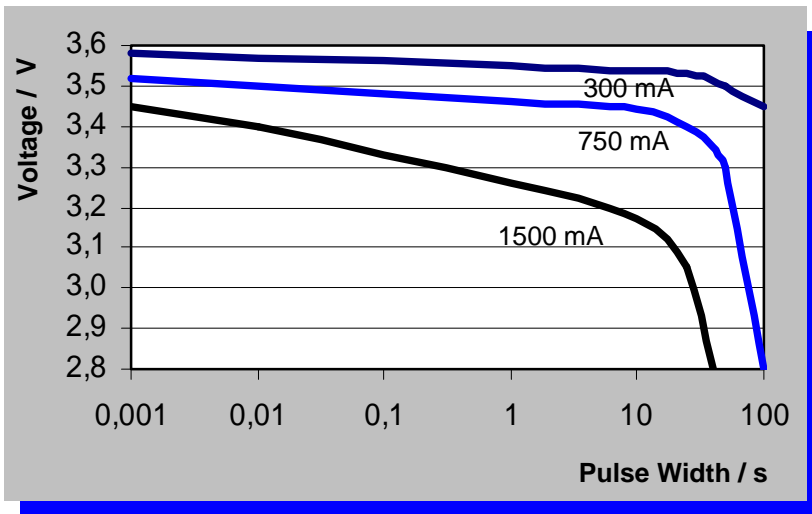

Discharge Characteristics @ 25 °C

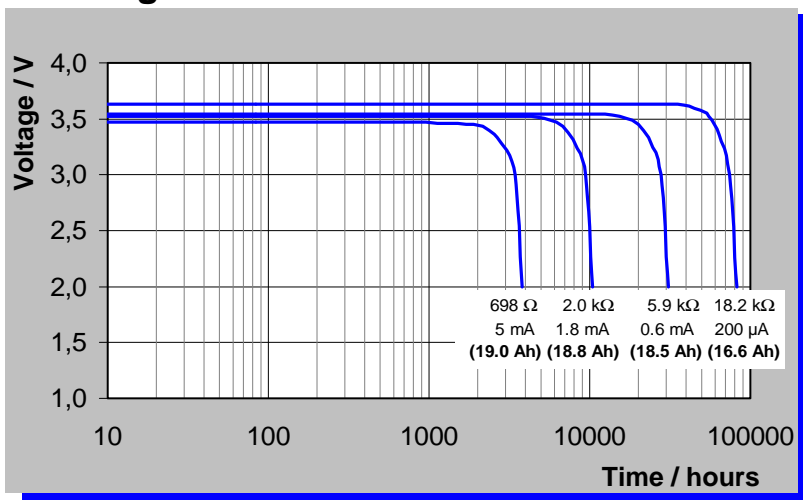

PATENTED TECHNOLOGY

Pulses Plus™ For High Pulse-Current Applications



Any values given here are for information purposes only. They also depend on actual conditions of use and are not warranties of future performance. Subject to change.

Minimum Voltage

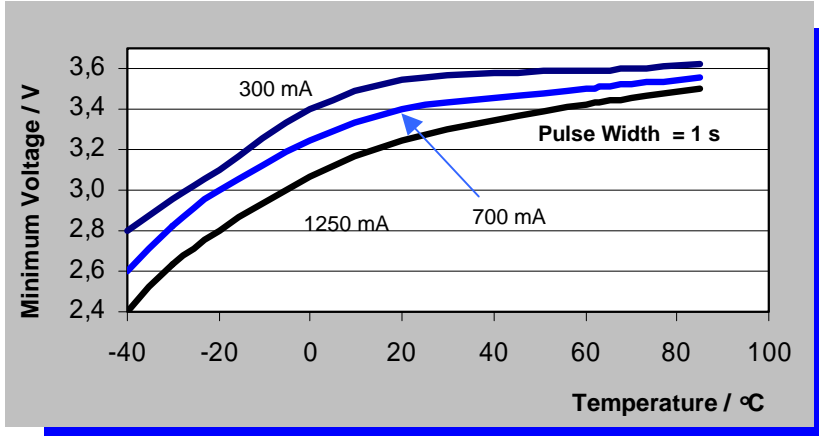

TLP-93111/A

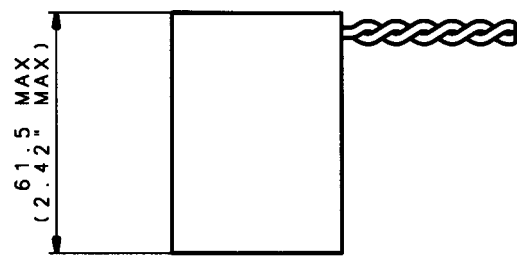

Self Discharge

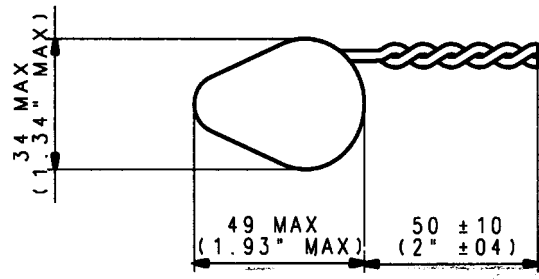
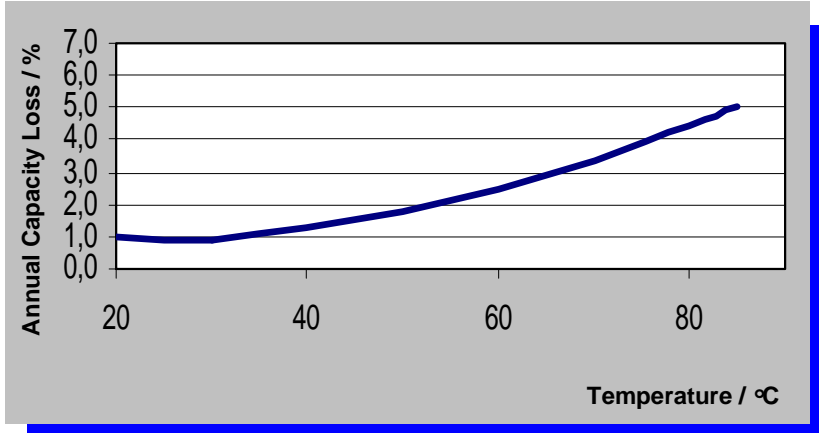

Maximum Pulse Width to Min. Voltage of 3.0 V at RT

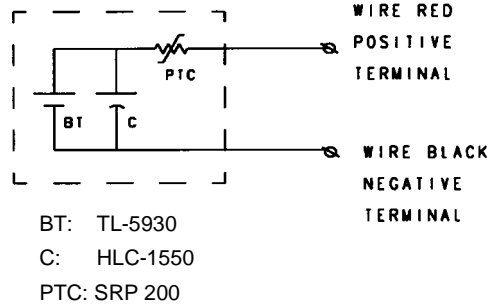
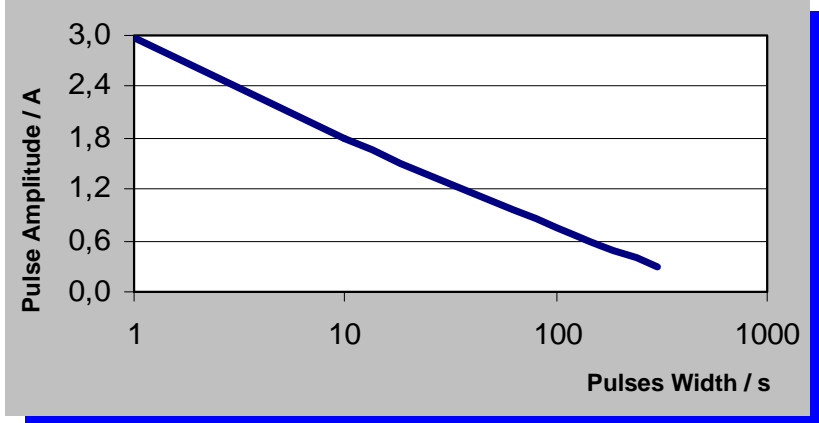

NOTE:
 SPECIAL CONNECTORS ARE
 AVAILABLE UPON REQUEST.

PATENTED TECHNOLOGY

Pulses Plus™ For High Pulse-Current Applications



Any values given here are for information purposes only. They also depend on actual conditions of use and are not warranties of future performance. Subject to change.

Hybrid Layer Capacitor (HLC)

Model HLC 1520



Model HLC 1550



Characteristics per Model (used in a Pulses Plus™ battery)

Dimensions and Weights

Length:	19.7 ± 0.3 mm	50.2 ± 0.3 mm
Diameter:	15.0 mm max.	15.0 mm max.
Weight:	7.9 ± 0.2 g	20.5 ± 0.5 g

Electrical Characteristics

Discharge:

Discharge capacity	(100 mA @ RT)	(250 mA @ RT)
When charged to 3.67 V:	12 mAh	48 mAh
When charged to 3.90 V:	80 mAh	320 mAh
Discharge end voltage:	2.8 V	2.8 V
(Discharge below 2.5 V may increase the HLC internal impedance)		

Maximum discharge current:

continuous:	250 mA	1 A
pulse (1 sec to 3.0 V)		
when charged to 3.67 V	1 A	3 A
when charged to 3.9 V	1 A	5 A

Charge:

Max. charge voltage:	3.95 V	3.95 V
(for testing purpose)		
Max. charging current:	25 mA	100 mA
(When tested separately from the primary cell)		

Cell impedance (at RT @ 1 kHz):	≤ 250 mΩ	≤ 150 mΩ
---------------------------------	----------	----------

Pulses Plus™

For High Pulse-Current Applications



Any values given here are for information purposes only. They also depend on actual conditions of use and are not warranties of future performance. Subject to change.

Characteristics valid for models HLC 1520 and HLC 1550

Shelf life:

Shelf life at different storage temperatures to 80% of initial capacity.

Temperature	HLC used independently	HLC in Pulses Plus™ battery
RT	1 year	10 years
60 °C	1 week	10 years
85 °C	Not applicable	At least 2 years

Number of charge-discharge cycles to 80% of initial capacity:

	100% DOD	10% DOD	1% DOD
Charged to 3.67V	4000	40000	400000
Charged to 3.90V	700	7000	70000

DOD (Depth Of Discharge)

Safety characteristics: The HLC successfully passed the following tests according to UL 1642 specification for lithium batteries.

- Short circuit test
- Crush test
- Impact test
- Vibration test
- Abnormal charging test
- Temperature cycling test
- Shock test
- Forced discharge test

The HLC is UL recognized under File No. MH 12192,

Temperature range:

	HLC used independently	HLC in Pulses Plus™ battery
Operating temperature	-30 to 60 °C	-40 to 85 °C
Storage temperature	-30 to 60 °C	-40 to 90 °C

Warning:

- The HLC is designed to be used in a Pulses Plus™ battery only.
- The HLC may explode or violently vent if over-charged above 4.4 V.
- Charging the HLC at above 3.95 V may lead to capacity loss and / or internal impedance rise.
- Do not charge the HLC above 3.95 V, force discharge, short circuit, heat above 100 °C, incinerate or expose contents to water.

Pulses Plus™

For High Pulse-Current Applications



Any values given here are for information purposes only. They also depend on actual conditions of use and are not warranties of future performance. Subject to change.



Sonnenschein Lithium GmbH
Industriestraße 22
D-63654 Buedingen, Germany
Tel.: +49 (0) 60 42/ 81 517
Fax.: +49 (0) 60 42/ 81 523
E-Mail: info@sonnenschein-lithium.de
Internet: <http://www.sonnenschein-lithium.de>