

FD178A/FD178B/FD178C

Version : A.010
Issue Date: 2011/3/1
File Name: SP-FD178-A.010.doc
Total Pages: 10

*Single Coil Brushless DC Motor Drivers with
Soft-Switching and PWM control
(2 to 6.5 Volts)*



SILICON TOUCH TECHNOLOGY INC.
新竹市科學園區展業一路九號七樓之一
9-7F-1 Prosperity Road I Science-Based Industrial Park
Hsinchu, Taiwan 300, R.O.C.
Tel : 886-3-5645656 Fax : 886-3-5645626

General Specifications

Designed for rotation speed control of single coil DC brushless fans, the FD178 series motor drivers minimize external component count and integrate all the key features required for high efficiency and low noise fans. Specifically PWM control and soft switching are provided to control the rotation speed and reduce the audible noise. Internal circuit protection includes thermal shutdown with hysteresis, rotor lock protection, and reverse power polarity protection. Three frequency generation (FGR pin) options are provided for different fan configurations - FG (FGR signal following Hall sensor output frequency), FG/2 (divided by two version of FG), and RD (rotation detection) for FD178A, FD178B, and FD178C respectively.

Features and Benefits

- Support single-phase full wave Brushless DC Motor Driver
- Built-in Hall sensor input signal amplifier
- PWM control circuit
- Low voltage startup (VDD=2V)
- High driving capability
- Lock detection and automatic self-restart
- Power polarity reverse protection
- Thermal shut down protection circuit
- Thin, compact, highly reliable package (TSOT-28)

Pin Description

FD178A/FD178B/FD178C : TSOT-28

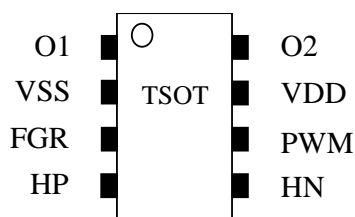

Package : TSOT-28

NO.	NAME	DESCRIPTION
1	O1	Output driving & sinking pin 1
2	VSS	Ground pin
3	FGR	Frequency generator or rotating detector FD178 : FG FD178B : FG/2 FD178C : RD
4	HP	Hall sensor in+
5	HN	Hall sensor in-
6	PWM	PWM control pin
7	VDD	Power supply pin
8	O2	Output driving & sinking pin 2

Absolute Maximum Ratings

(Unless otherwise noted, VDD=5V, T_A = 25 °C)

Characteristic	Symbol	Rating	Unit
Supply Voltage	V _{DDM}	6.5	V
Operation Current	I _{OUT}	500	mA
Output Current at Locked (TSOT-28)	I _{OL1}	1	A
Maximum FGR Output Current	I _{FGR_MAX}	10	mA
Maximum FGR Output Voltage	V _{FGR_MAX}	6.5	V
Operating Temperature Range	T _{OPR}	-30 ~ 85	°C
Storage Temperature Range	T _{STG}	-65 ~ 150	°C
Power Dissipation (TSOT-28)	P _D	568	mW
Thermal Resistance, Junction to Ambient	θ _{JA_TSOT28}	220	°C/ W
Thermal Resistance, Junction to Case	θ _{JC_TSOT28}	92	°C/ W
Maximum Junction Temperature	T _{j(max)}	150	°C

Electrical Characteristics

(Unless otherwise noted, VDD=5V, T_A = 25 °C)

Characteristic	Sym.	Condition	Limit			Unit
			Min.	Typ.	Max.	
Operation Voltage	V _{DD}	-	2	5	6.5	V
Supply Current	I _{CC}	-		3	5	mA
Maximum Output Voltage Range	V _{OH}	I _{OUT} = 250 mA	4.5	4.65	-	V
Minimum Output Voltage Range	V _{OL}	I _{OUT} = 250 mA	-	0.35	0.5	V
FG Output Low Voltage	V _{FGROL}	I _{FGR} = 5 mA	-	0.25	0.4	V
Hall Amplifier Offset	V _{Offset}	-	-9	0	9	mV
Input-Output Gain	G _{IO}	-	45	48	51	dB
Automatic self-restart						
Lock detection on Time	T _{ON}	-	110	150	190	ms
Lock detection off Time	T _{OFF}	-	0.75	1.05	1.35	Sec
PWM signal control						
PWM input frequency	V _{PWM}	-	-	25	50	KHZ
PWM input high level voltage ^{*1}	V _{IH}	-	0.55VDD	VDD	VDD+0.4	V
PWM input low level voltage ^{*1}	V _{IL}	-	-0.3	0	0.2VDD	V
Hall signal output						
Hall average output DC voltage	V _{DC}	-	400	-	-	mV
Hall amplitude of waveform voltage	V _{Am}	-	150	-	-	mV

^{*1} Description in the page4 "PWM input high and low level voltage"

Thermal shut down protection circuit						
Shut down temperature		-	160	180	200	°C
Release temperature		-	120	140	160	°C

Truth Table

PWM	Hall input	O1	O2
L	X	L	L
H	HP > HN	H	L
H	HP < HN	L	H

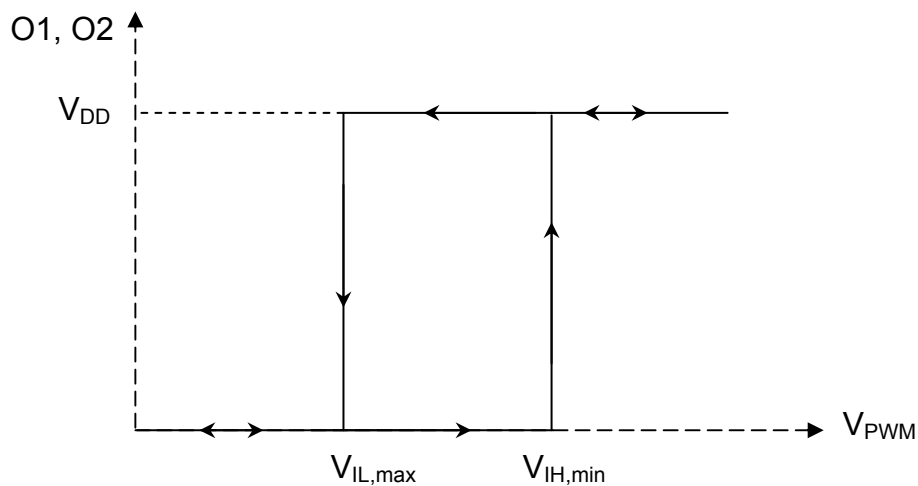

Hall Signal

- For a stable operation, the Hall sensor output is required to meet the following conditions.
 - (a) The DC level of Hall signal is greater than 400 mV
 - (b) The amplitude of Hall signal is greater than 150mV

HP or HN

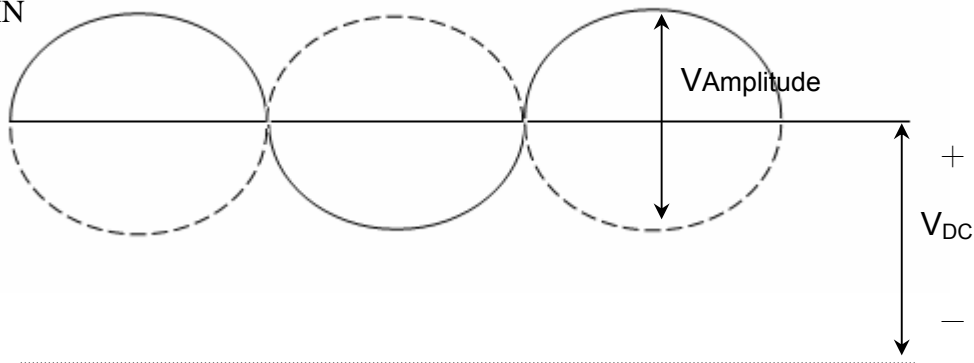

Application Circuit

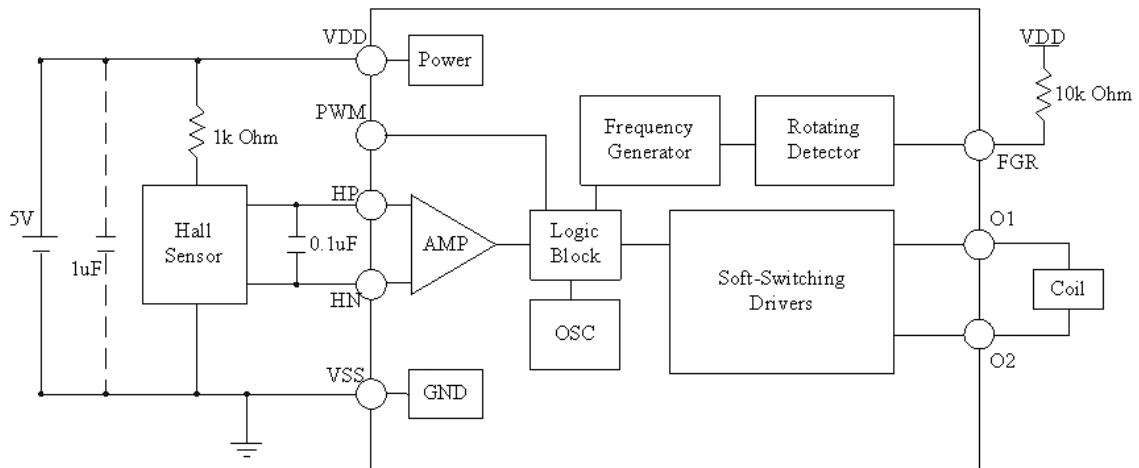

- The connection of the capacitor between VDD and GND will increase stability of operation, if required.

Output Waveform

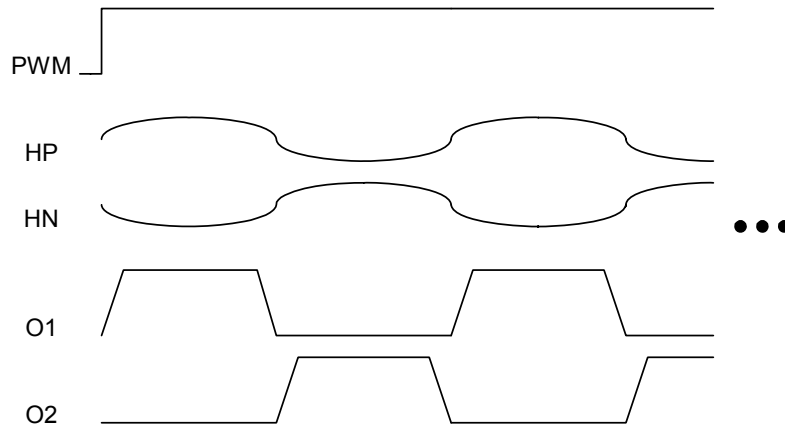

PWM control

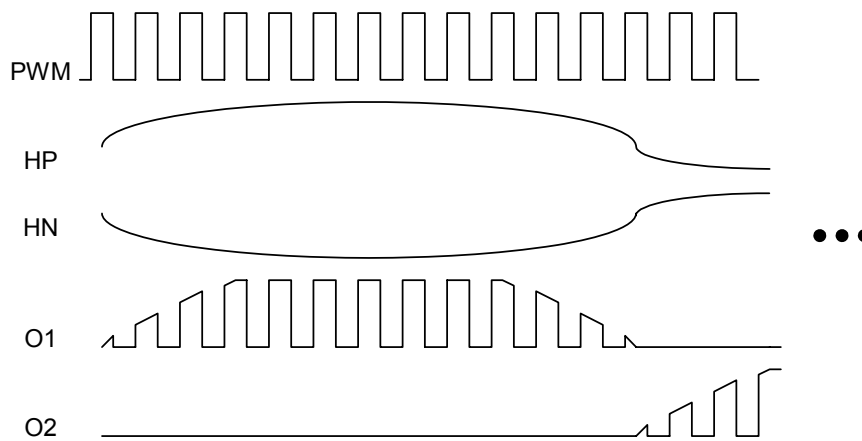

Application Notes

- The device can be operated with a wide supply voltage ranging from 2 to 6.5 Volts. However, the design, specifications, and performance have been optimized for 5V brushless dc motor applications.
- The output driver node O1/O2 are in drive/sink state when V(HP) > V(HN) and vice versa
- The lock and auto-restart do not require an external capacitor for a timing counting purpose. The driver will be shutdown approximately 1 second after the motor is lock and the auto-restart is activated every one second until the lock is released.
- Eliminating an external protection diode, a power polarity reverse circuit is integrated on the chip.
- A 1uF capacitor between VDD and GND as well as a 0.1uF between HP and HN are strongly recommended for a reliable and noise immune operation.
- The power dissipated by the chip varies with the supply voltage. It is advisable to ensure the power dissipation by the chip does not exceed the thermal requirement dictated by the package. The maximum allowable power consumption can be calculated by the following equation:

$$Pd(\text{Power Dissipation})(\text{Watt}) = \frac{Tj(\text{Junction Temperature})(\text{max})(^{\circ}\text{C}) - Ta(\text{Ambient Temperature})(^{\circ}\text{C})}{\theta_{JA}(\text{Thermal Resistance, Junction to Ambient})(^{\circ}\text{C}/\text{Watt})}$$

The relationship between power dissipation and operating temperature can refer to the figure below:

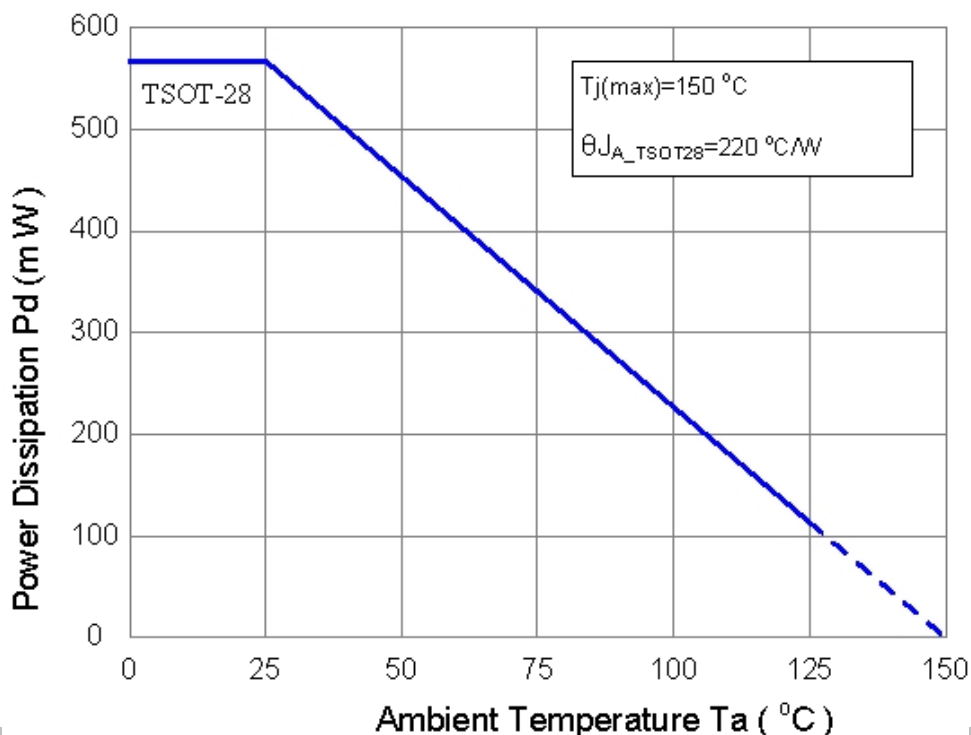

Package Specifications
FD178 : TSOT-28

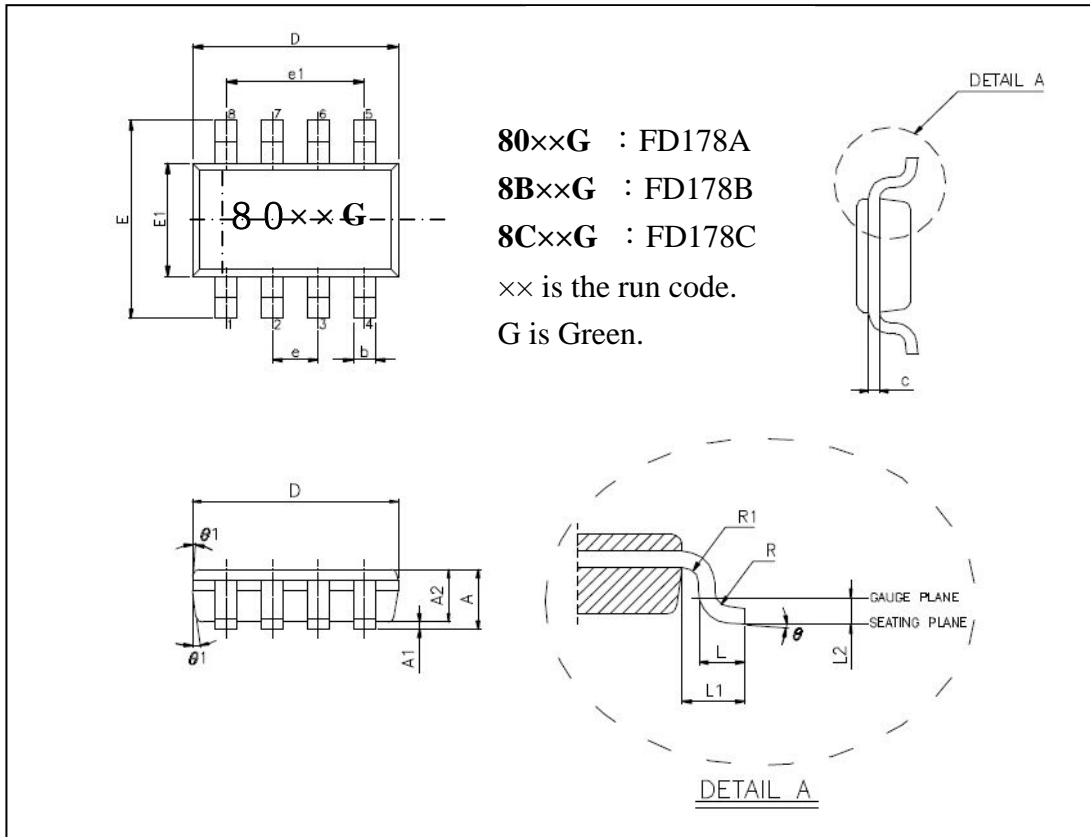

VARIATION(ALL DIMENSIONS SHOWN IN MM)

SYMBOL	MIN.	NOM.	MAX.
A	0.750	-	0.800
A1	0	-	0.050
A2	0.700	0.750	0.775
b	0.220	-	0.380
c	0.100	-	0.200
D	2.800	2.900	3.000
E	2.600	2.800	3.000
E1	1.500	1.600	1.700
e	0.650 BSC		
e1	1.950 BSC		
L	0.370	0.450	0.600
L1	0.600 REF		
L2	0.250 BSC		
R	0.100	-	-
R1	0.100	-	0.250
θ	0°	4°	8°
θ1	4°	10°	12°



The products listed herein are designed for ordinary electronic applications, such as electrical appliances, audio-visual equipment, communications devices and so on. Hence, it is advisable that the devices should not be used in medical instruments, surgical implants, aerospace machinery, nuclear power control systems, disaster/crime-prevention equipment and the like. Misusing those products may directly or indirectly endanger human life, or cause injury and property loss.

Silicon Touch Technology, Inc. will not take any responsibilities regarding the misuse of the products mentioned above. Anyone who purchases any products described herein with the above-mentioned intention or with such misused applications should accept full responsibility and indemnify. Silicon Touch Technology, Inc. and its distributors and all their officers and employees shall defend jointly and severally against any and all claims and litigation and all damages, cost and expenses associated with such intention and manipulation.

Silicon Touch Technology, Inc. reserve the right to make changes to their products or to discontinue any product or service without notice, and advise customers to obtain the latest version of relevant information to verify, before placing orders, that information being relied on is current and complete.