

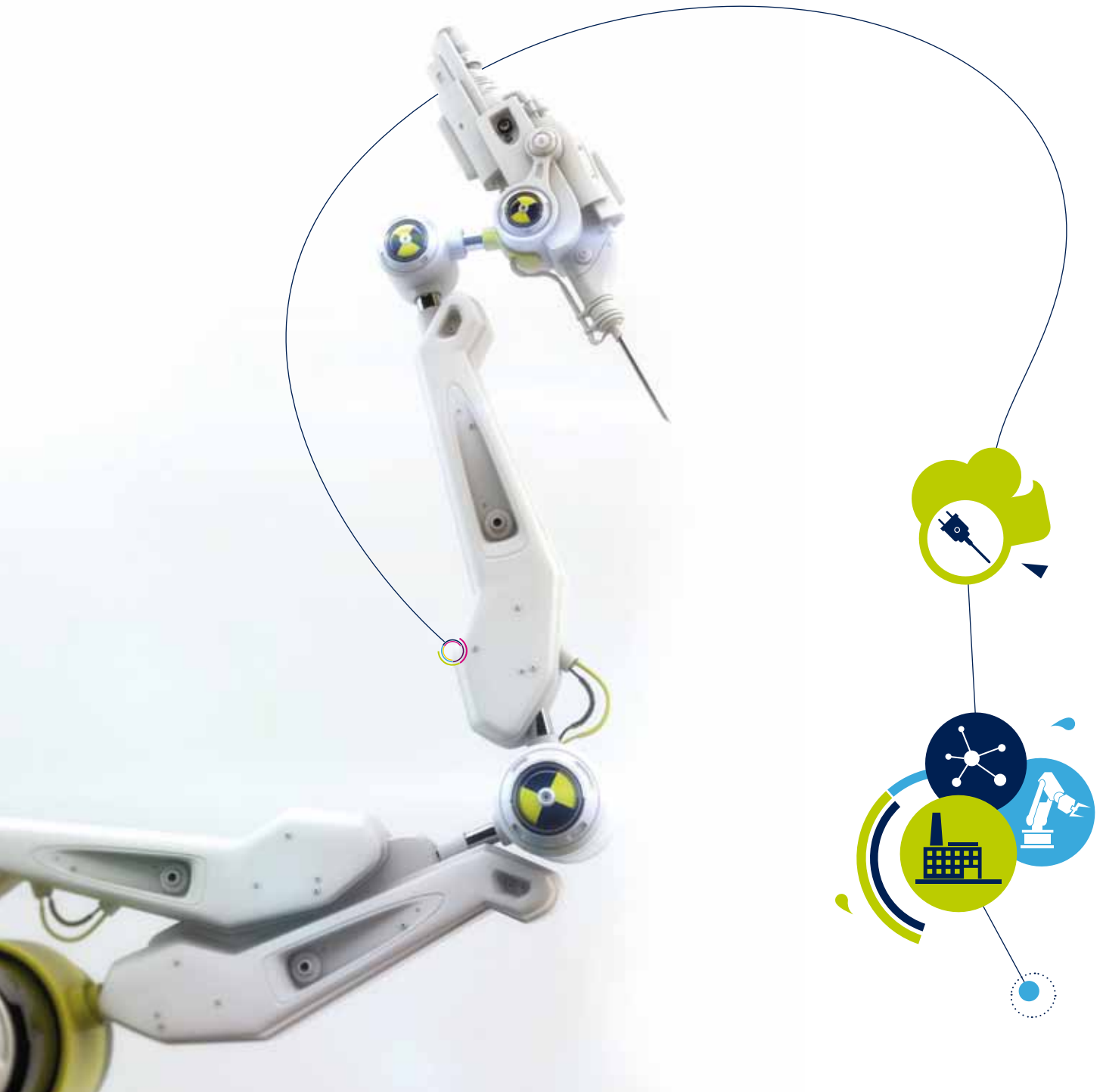

life.augmented

# Products and solutions for Factory automation and control





# Content

<b>Introduction</b> .....	<b>3</b>
Trends in factory and process automation .....	4
Factory automation and standards: how to implement safety .....	4
ST and factory automation: a strong link .....	5
<b>Supervisor layer</b> .....	<b>6</b>
Touch sensors .....	7
Display and LED controllers .....	7
RF interfaces .....	8
<b>Control layer</b> .....	<b>10</b>
Control unit .....	11
Analog and Digital IO .....	18
Data communication interface ICs .....	24
Serial real-time clock (RTC ) ICs, reset and supervisor ICs .....	27
Memories .....	28
Power supplies .....	28
Protection devices .....	31
<b>Field layer</b> .....	<b>34</b>
Field bus and industrial Ethernet HW implementation .....	35
IO-Link .....	36
Local control .....	37
Monitoring and sensing .....	39
Actuators and motor control .....	43
Signal conditioning .....	51





# Introduction

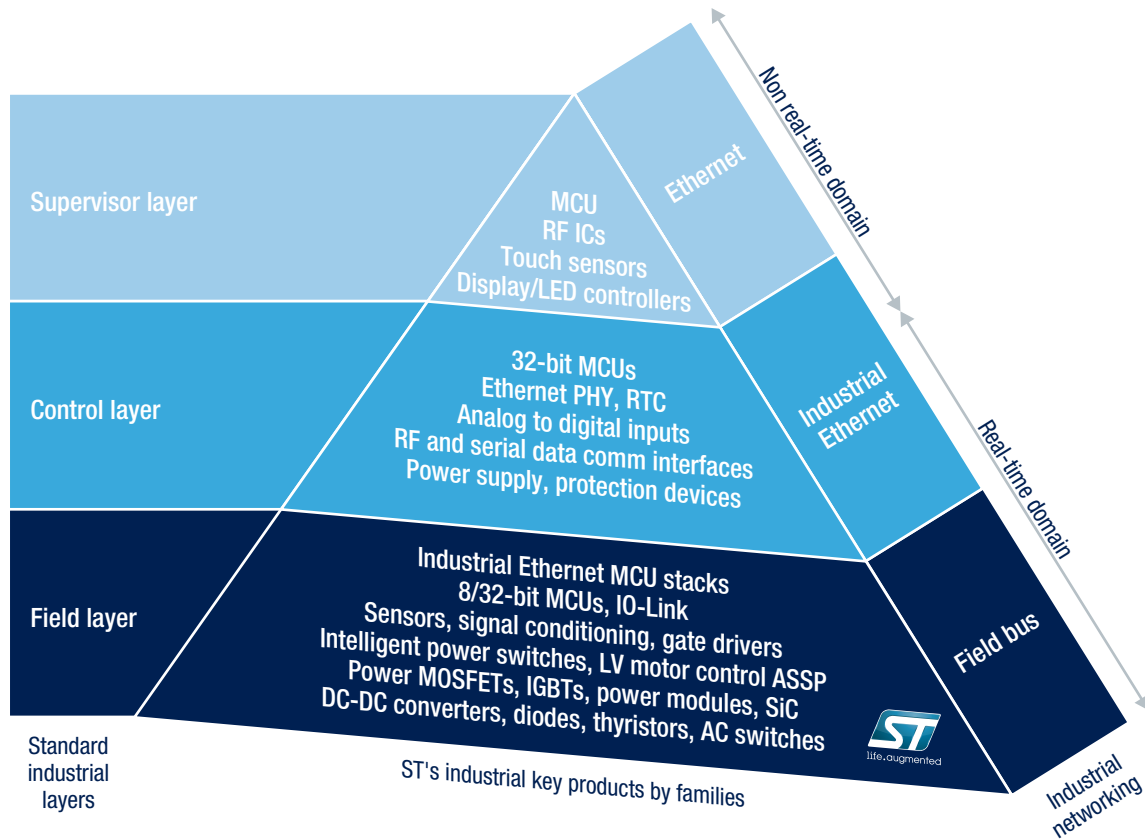

## Overview

This reference guide covers ST's portfolio for factory automation, and how ST's devices and solutions can help you.

The world of factory automation uses electronic equipment to get the best process performances, the safest working environment for human operators and the best economic conditions for the industrial plant. ST is a key semiconductor player in this field and offers tens of thousands of devices, together with support tools including reference designs, demonstration boards and application software.

The structure of the brochure is organized following the standard model depicted in Figure 1. Starting from the top of the CIM (computer integrated manufacturing) diagram, the chapters are organized as the layers of the pyramid and each of them contains an introductory block diagram (to clarify the application) followed by the ICs ST suggests for implementation.

### STAY UP-TO-DATE

For more information and up-to-date material, visit the factory automation application page on ST's website at: [www.st.com/factory-automation](http://www.st.com/factory-automation)

### MORE INFO

The CIM model presented here was introduced in the 1980s to establish a hierarchy in the manufacturing industries.

## TRENDS IN FACTORY AND PROCESS AUTOMATION

Factory automation, control and motor drives is a global market estimated at about 12 B\$ in 2014 (Semicast Research, 2012), resulting in the production of around 500 million systems, ranging from power converters and sensors to PLCs and robotic systems.

The global semiconductor market is divided into 4 major regions: Americas, Europe, Japan and Asia Pacific. The Asia Pacific growth rate is twice that of the other regions.

In today's industrial automation market, upcoming trends, such as green energy, energy saving, increased labor safety with decreased labor costs, have opened up many new opportunities for industrial system developers. System designers can address these evolving challenges using advanced semiconductor technologies and their derived system-oriented products.

The challenges of reliability, safety, EMC environment and product life require close cooperation between the semiconductor expert and system design expert. The combined expertise results in ST's highly advanced system-oriented products.

ST provides the factory and process automation industry with an extensive product portfolio ranging from the highly popular ARM-based microcontrollers, through memories, discrete power products, supported by analog ICs for dedicated industrial drivers, interfaces, wireless transceivers and amplifiers.

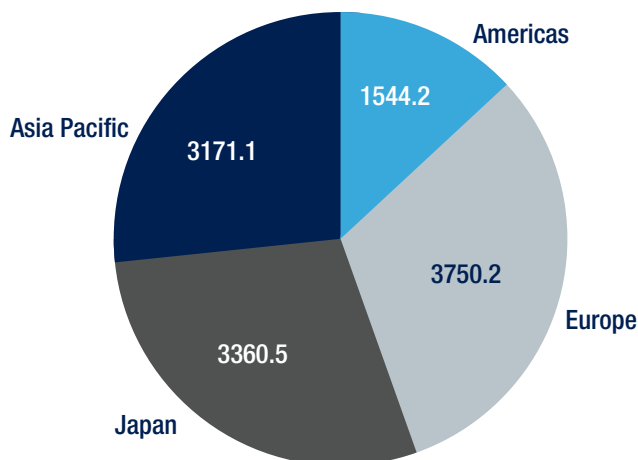

The global market for semiconductors in factory automation, control and motor drives by region in 2014 (Semicast Research, 2012)

Our leading-edge smart power and power semiconductor process technology, coupled with significant manufacturing capacity, allow us to offer products proven under the harsh industrial environment so our customers can design outstanding products.

By offering tailored solutions, a rich ecosystem of products, software tools, reference designs and support, we enable industrial system developers to design robust automation applications.

## FACTORY AUTOMATION AND STANDARDS: HOW TO IMPLEMENT SAFETY

### Safety is the cornerstone of factory automation: ST's ICs are designed accordingly

Factory automation environments must be intrinsically safe: ST, as a semiconductor company, has a key role to play, and makes safety a cornerstone for its product offering. The main standard for functional safety is EN61508, which concerns electrical, electronics and programmable electronics devices (E/E/PE) and all the branches dedicated to factory automation.

This standard also defines the safety integrity levels (SIL) which measure how safe a system is in terms of the reduction in risk for the operators. ST's ICs take into consideration EMI disturbances and comply with IEC 61800-3. Complex power management stages can thus be designed with a high level of robustness.

At ST, functional safety is not only built into the hardware, but also our MCU and MPU software. Effectively, our processing ICs come with software libraries to help designers in their development, and all this software is certified according to primary targeted safety standards to ensure functional safety.



### KEY STANDARDS

- IEC 61010: Safety requirements for electrical equipment for measurement, control and laboratory use
- EN61508: Functional safety of electrical/electronic/programmable electronic safety-related systems
- IEC 61800: Adjustable speed electrical power drive systems
- ISO 13849-1: machinery standard
- IEC 62061: dedicated to factory automation systems

## ST AND FACTORY AUTOMATION: A STRONG LINK

A broad spectrum IC provider, ST is a valued partner with wide experience and specific know-how

ST has strong links with the factory automation world. ST offers thousands of dedicated devices, from drivers, power transistors and protection devices, to high-end MCUs. We also support development with dedicated evaluation tools. In addition, we have many partnerships with key players in associations and consortiums, as described here.

As an example, ST is part of the IO-Link association, aimed at implementing a standard communication protocol at low level among end units, such as sensors and control units. It involves strong links with many key players in industrial automation as shown in the figure. As an active member, ST has developed transceivers implementing the protocol's physical layer, as well as the associated evaluation boards and software tools.

On the industrial Ethernet side, protocols, such as Profinet, Powerlink, EtherCAT and many others, are supported by third parties with complete hardware/software resources, embedding our high-performance MCUs.

These are just some examples of the effort ST dedicates to industrial Ethernet. Others could be given, such as CANopen, to show the extent of ST's involvement in the industrial world, through partnerships and the most important associations.

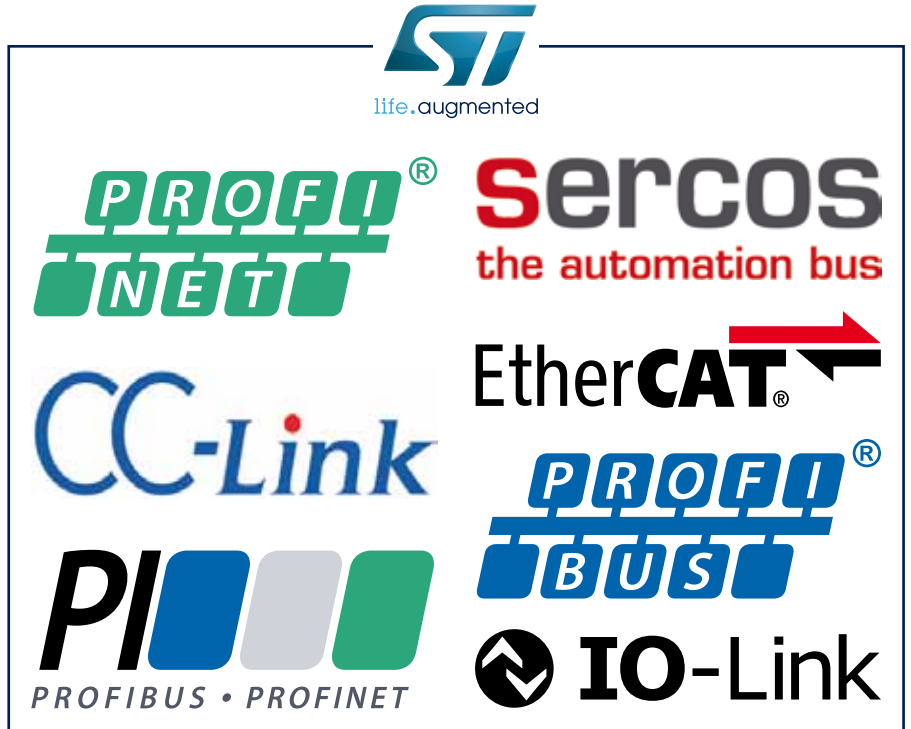

### EVALUATION BOARDS

Evaluation boards for the industrial segment can be found at:  
[www.st.com/web/en/catalog/tools/FM116/SC1076](http://www.st.com/web/en/catalog/tools/FM116/SC1076)





# Supervisor layer

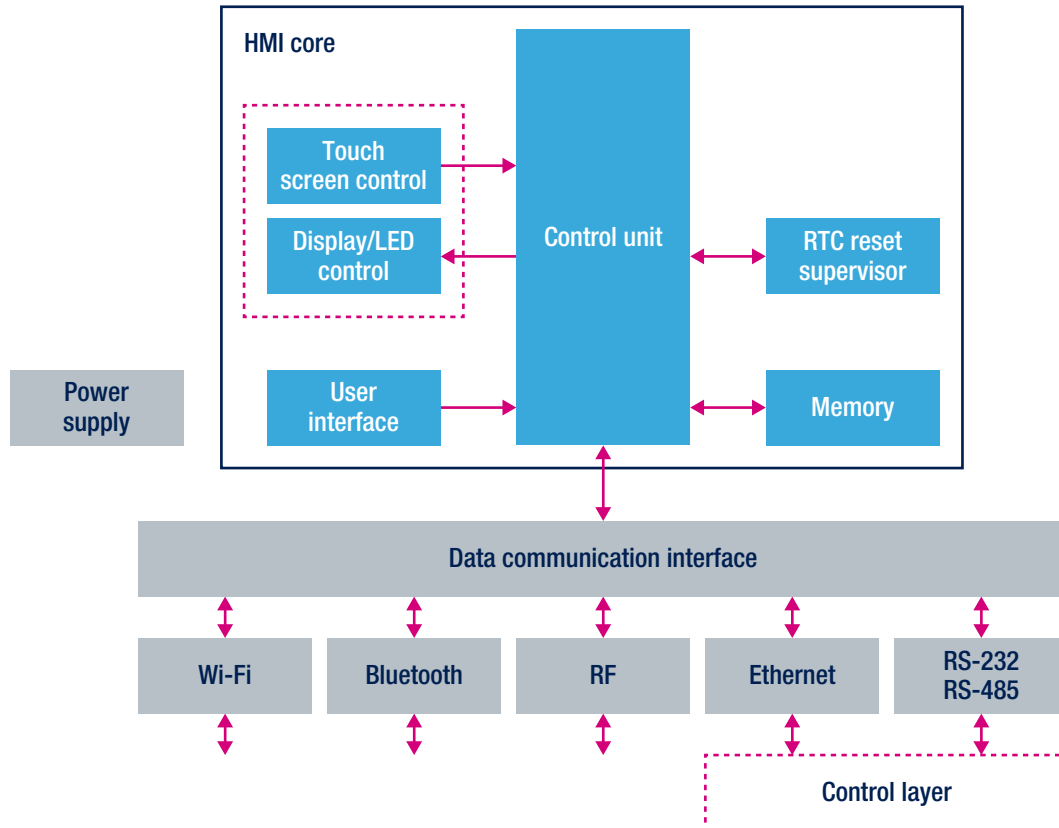

6

Using the CIM pyramid for the industrial environment, we start with a typical supervisor layer. Human-machine interfaces (HMI) and, in general, user-friendly interfaces are primordial at this level. The aim is to simplify and get shorter execution time for the first level commands associated with the supervisor. The main device families associated with these interfaces are:

- Touch sensors
- Display/LED controllers
- RF interfaces

These devices are covered in this chapter, whereas other parts such as the control unit, data communication interfaces or power supply that are common to the other levels are treated in the following chapters.

## TOUCH SENSORS

### Touch sensing libraries for 32-bit MCUs

To complement the traditional MCU functions, STM32 F0, F3, L1 series are now equipped with a Touch Sensing Controller (TSC). TSC use capacitive technology and manages capacitive sensing acquisition automatically without CPU intervention. Up to 24 touches can be implemented such as touchkeys and/or linear/rotary touch sensor.

To ease development the corresponding Touch sensing libraries are available:

- 32F3-TOUCH-LIB: touch library for STM32 F3 series (64kB to 256kB - 48, 64, 100 pins)
- 32F0-TOUCH-LIB: touch library for STM32 F0 series (16kB to 128kB - 32, 48, 64, 100 pins)
- 32L1-TOUCH-LIB: touch library for STM32 L1 series (16kB to 512kB - 32, 48, 63, 64, 100, 132, 144 pins)



## DISPLAY AND LED CONTROLLERS

### LED drivers and monitor ICs

ST offers a large portfolio of energy-efficient LED drivers for general lighting, display backlighting, signage and industrial panels. Ideal for both parallel and series configurations, they enable high-efficiency, high-current accuracy, low-noise and small-size solutions. Topologies include buck regulator LED drivers, boost regulator LED drivers, offline LED drivers, and more.

([www.st.com/led](http://www.st.com/led))

ST's extensive portfolio of monitor ICs is available at [www.st.com/displays](http://www.st.com/displays).

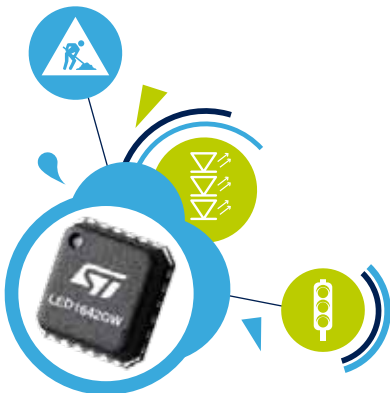



## RF INTERFACES

### BlueNRG: Bluetooth® 4.0 low energy network processor

Targeted for security and proximity applications, the BlueNRG is a very low-power Bluetooth low energy (BLE) single-mode network processor, compliant with Bluetooth specification v4.0.

This device is also suitable in the lower levels of any Industrial environment.

Ultra low-power sleep modes and very short transition time between operating modes allow very low average current consumption, resulting in longer battery life ([www.st.com/bluemodules](http://www.st.com/bluemodules)).



### KEY FEATURES

- Bluetooth specification v4.0 compliant master and slave single-mode Bluetooth low-energy network processor
- Embedded Bluetooth low energy protocol stack: GAP, GATT, SM, L2CAP, LL, RF-PHY
- Bluetooth low energy profiles provided separately
- Operating supply voltage: 2.0 to 3.6 V
- 8.2 mA maximum Tx current (@ 0 dBm, 3.0 V)
- Down to 1.7 µA current consumption with active BLE stack
- Integrated linear regulator and DC-DC step-down converter
- Up to +8 dBm available output power (at antenna connector)
- Excellent RF link budget (up to 96 dB)
- Accurate RSSI to allow power control
- Integrated general-purpose ADC
- Proprietary application controller interface (ACI), SPI based, allows interfacing with an external host application microcontroller
- Full link controller and host security
- High-performance, ultra-low-power Cortex-M0 32-bit based architecture core
- On-chip non-volatile Flash memory
- AES security coprocessor
- Low-power modes
- 16 or 32 MHz crystal oscillator
- 12 MHz ring oscillator
- 32 kHz crystal oscillator
- 32 kHz ring oscillator
- Battery voltage monitor and temperature sensor
- Compliant with the following radio frequency regulations: ETSI EN 300 328, EN 300 440, FCC CFR47 Part 15, ARIB STD-T66
- Available in QFN32 (5 x 5 mm) package
- Operating temperature range: -40 to 85 °C

8

### STBT2632C Bluetooth modules

Bluetooth modules are also available for both class-1 and class-2 specifications. Already optimized and ready to use, they come with the following common features:

### KEY FEATURES

- Bluetooth radio
  - Fully embedded Bluetooth v3.0 with profiles
  - Class 1 or 2 module
  - Complete RF ready module
  - 128-bit encryption security
  - Integrated antenna
  - Multipoint capability
- Cortex-M3 microprocessor up to 72 MHz
- Memory
  - 256-Kbyte Flash memory
  - 48-Kbyte RAM memory
- Data rate
  - 1.5 Mbit/s maximum data rate
- Serial interface
  - UART up to 2.0 Mbit/s
  - SPI interface
- General I/O
  - Up to 16 general-purpose I/Os
  - 1 LPO input (SPBT2632C2A)
- User interface
  - AT2 command set (abSerial)
  - Firmware upgrade over UART
- FCC and Bluetooth qualified
- EPL (end product listing) fulfilled
- Single voltage supply: 2.5 V typical
- Operating temperature range: -40 to 85 °C



SPBT2632C1A  
Bluetooth® technology class-1 module



SPBT2632C2A  
Bluetooth® technology class-2 module



### Wi-Fi modules

ST's latest series of Wi-Fi modules offers a fast, flexible and affordable Plug&Play solution for integration of 802.11 b/g/n and TCP/IP technologies in IoT devices.

The modules integrate a complete TCP/IP stack and a user-friendly application layer that ensures a simple and effective way to use the modules via AT commands. The modules are configured around a single-chip 802.11 transceiver with integrated PA and an STM32 32-bit microcontroller with extensive GPIO support. The modules also incorporate timing clocks and voltage regulators. Multiple antenna options are available.

With reduced power consumption and small form factor, the modules are ideal for both fixed and mobile wireless applications.

The modules are fully qualified and RoHS compliant.



SPWF01SA



SPWF01SC

These modules are the ideal choice for industrial control and data acquisition.

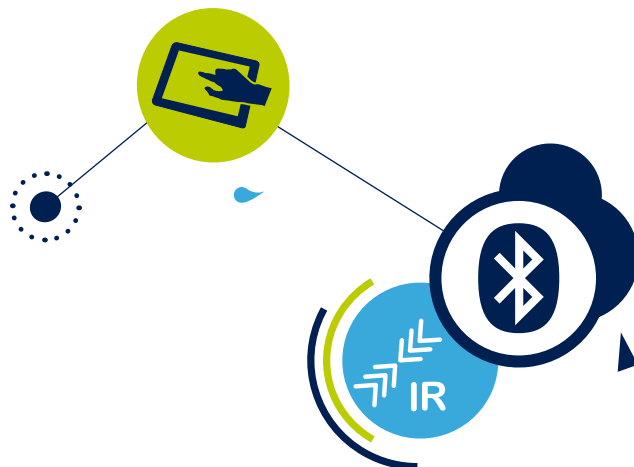



# Control layer

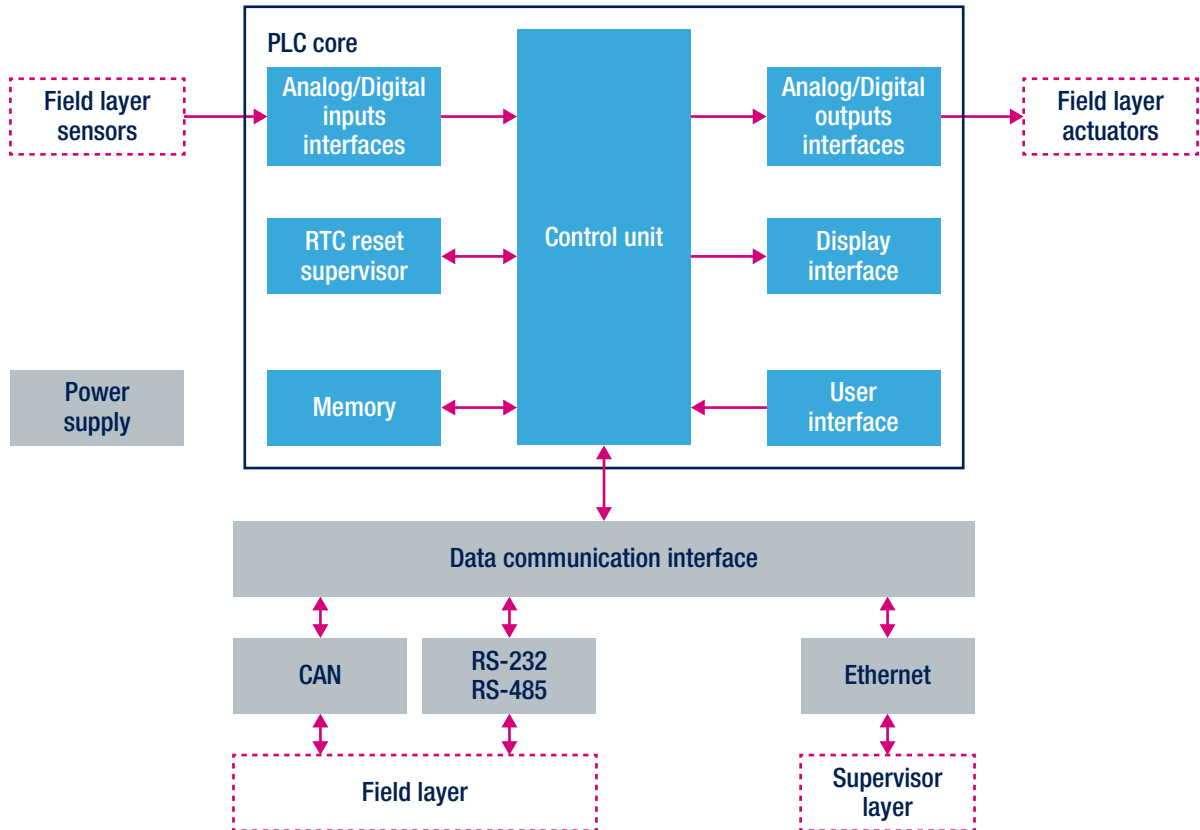

10

Perhaps the single most important device that represents factory automation is the PLC (programmable logic controller). Introduced in the late 1960s, PLCs are designed for real-time processing of a large number of IO in industrial plants. What differentiates a PLC in the market is its IO capacitance (identified by the number of IO and the related scan rate) and its computational performances.

The control layer is a key market for ST: the TAM (total available market) for 2017 is forecast at 4 B\$ (IHS iSuppli industrial electronics Q4 2012 market tracker).

Over the years, ST has developed thousands of ICs dedicated to factory automation, and the current portfolio is the result of continuous improvements, compliance with the latest electrical and safety standards, customers' needs and R&D activity.

The product families shown in the block diagram are covered in dedicated sections. See also [www.st.com/factory-automation](http://www.st.com/factory-automation).

Each section contains a list of ICs and the related tools, as well as evaluation boards.

# CONTROL UNIT

## MCU portfolio

By choosing one of ST's microcontrollers for your embedded application, you gain from our leading expertise in MCU architecture, technology, multi-source manufacturing and support.

ST's product portfolio contains a comprehensive range of microcontrollers, from robust, low-cost 8-bit MCUs, the STM8 family, up to 32-bit ARM-based Cortex™-M0, Cortex™-M0+, Cortex™-M3, Cortex™-M4 Flash microcontrollers with a rich choice of peripherals, the STM32 family. Only the STM32 family is covered in this section, whilst the STM8 family is the subject of the field layer section.

Extensive support through a combination of flexible and powerful development tools, training courses, consultancy and web support gives you a plus for a faster time to market.

## STM32 32-bit microcontrollers

The STM32 family of 32-bit Flash microcontrollers based on the ARM Cortex™-M processor is designed to offer new degrees of freedom to MCU users. By bringing a complete 32-bit product range that combines high-performance, real-time, low-power and low-voltage operation, while maintaining full integration and ease of development, the STM32 family helps you create new applications and design in the innovations you have long been dreaming about.

### Common core peripherals and architecture:

Communication peripherals: USART, SPI, I <sup>2</sup> C
Multiple general-purpose timers
Integrated reset and brown-out warning
Multiple DMA
2x watchdogs Real-time clock
Integrated regulator PLL and clock circuit
Up to 19x 12-bit DAC
Up to 4x 12-bit ADC (Up to 5 MSPS)
Main oscillator and 32 kHz oscillator
Low-speed and high-speed internal RC oscillators
-40 to +85 °C and up to 105 °C operating temperature range
Low voltage 2.0 to 3.6 V or 1.65/1.7 to 3.6 V (depending on series)
Temperature sensor

### STM32 F4 series - High performance with DSP (STM32F401/405/415/407/417/427/437/429/439)

Up to 180 MHz Cortex-M4 DSP/FPU	Up to 2-Mbyte Flash	Up to 256-Kbyte SRAM	2x USB 2.0 OTG FS/HS	1x 12-bit AMC timer	2x CAN 2.0B	SDIO 2x I <sup>2</sup> S audio Camera IF	Ethernet IEEE 1588	LCD-TFT SDRAM I/F
---------------------------------	---------------------	----------------------	----------------------	---------------------	-------------	--	--------------------	-------------------



### STM32 F3 series - Mixed-signal with DSP (STM32F301/302/303/373/x8)

72 MHz Cortex-M4 with DSP and FPU	Up to 512-Kbyte Flash	Up to 64-Kbyte SRAM CCM-SRAM	USB 2.0 FS	3x 16-bit AMC timer (144 MHz)	CAN 2.0B	Up to 7x comparator 4x 12-bit DAC 4x PGA	HDMI CEC	3x 16-bit ΣΔ ADC
-----------------------------------	-----------------------	------------------------------	------------	-------------------------------	----------	--	----------	------------------



### STM32 F2 series - High performance (STM32F205/215/207/217)

120 MHz Cortex-M3 CPU	Up to 1-Mbyte Flash	Up to 128-Kbyte SRAM	2x USB 2.0 OTG FS/HS	1x 12-bit AMC timer	2x CAN 2.0B	SDIO 2x I <sup>2</sup> S audio Camera IF	Ethernet IEEE 1588	Crypto
-----------------------	---------------------	----------------------	----------------------	---------------------	-------------	--	--------------------	--------



### STM32 F1 series - Mainstream - 5 product lines (STM32F100/101/102/103 and 105/107)

Up to 72 MHz Cortex-M3 CPU	Up to 1-Mbyte Flash	Up to 96-Kbyte SRAM	USB 2.0 OTG FS	1x 12-bit AMC timer	Up to 2x CAN 2.0B	SDIO 2x I <sup>2</sup> S audio	Ethernet IEEE 1588
----------------------------	---------------------	---------------------	----------------	---------------------	-------------------	--------------------------------	--------------------



### STM32 F0 series - Entry-level (STM32F030/x1/x2/x8)

48 MHz Cortex-M0 CPU	Up to 128-Kbyte Flash	Up to 16-Kbyte SRAM 20-byte backup data	USB clock free	USB 2.0 FS Crystal less	CAN 2.0B	DAC comparator	CEC
----------------------	-----------------------	---	----------------	-------------------------	----------	----------------	-----



### STM32 L1 series - Ultra-low-power (STM32L100/151/152/162)

32 MHz Cortex-M3 CPU	Up to 512-Kbyte Flash	Up to 80-Kbyte SRAM	Up to 16-Kbyte EEPROM	USB 2.0 FS device	LCD 8x40 4x44	Op-amps comparator	BOR MSI VScal	AES 128-bit
----------------------	-----------------------	---------------------	-----------------------	-------------------	---------------	--------------------	---------------	-------------



### STM32 L0 series - Ultra-low-power (STM32L0x1/x2/x3)

32 MHz Cortex-M0+ CPU	Up to 64-Kbyte Flash	Up to 8-Kbyte SRAM	Up to 2-Kbyte EEPROM	USB 2.0 Crystal less	LCD 8x28 4x32	True RNG	BOR MSI VScal	AES 128-bit
-----------------------	----------------------	--------------------	----------------------	----------------------	---------------	----------	---------------	-------------



Before presenting some of the MCUs from the STM32 family, the diagram below shows how our microcontrollers are designated.

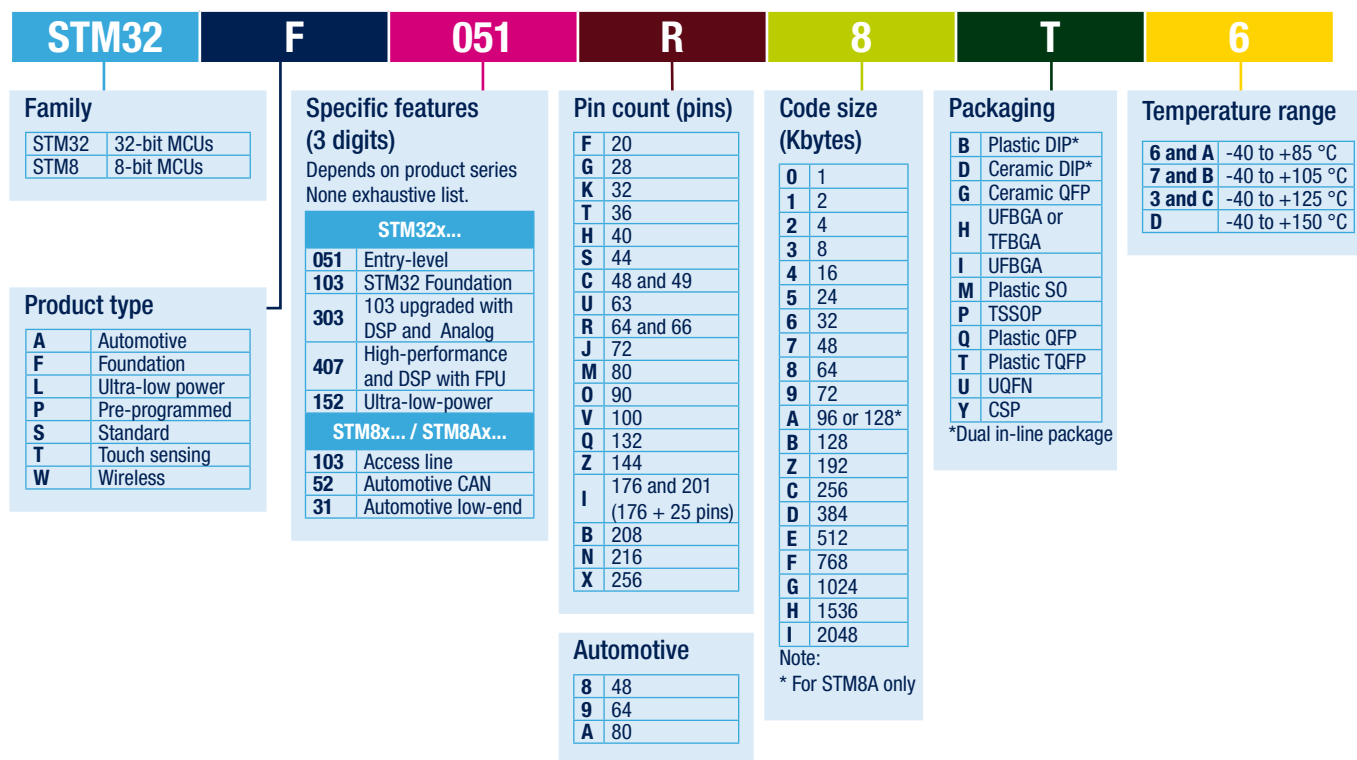

Including the ultra-low-power STM32 Lx series, the STM32 is divided into 7 product series and around 500 part numbers.

The table below shows only a few examples dedicated to industrial automation.

The STM32 devices listed in the table below are ordered by part name, in ascending order of complexity.

Part number	Flash size (Kbytes)	Internal RAM size (Kbytes)	Package	Timer functions		ADC	DAC	I/Os	Serial interface							Supply voltage (V)	Supply current (I <sub>cc</sub> )		Maximum operating temperature range (°C)	
				16-/32-bit timers	Others				SPI	FS	IC	USART + UART	USB FS or USB OTG FS + FS/HS	CAN 2.0B	SDIO		Ethernet MAC 10/100	Lowest power mode (µA)		Run mode (per MHz) (µA)
<b>STM32 F1 series - ARM Cortex™-M3 mainstream MCUs</b>																				
STM32F103ZC	256	48	LFBGA144, LQFP144	8x16-bit	2x WDG, RTC, 24-bit downcounter	21x12-bit	2x12-bit	112	3	2	2	3+2	1	1	1	2.0 to 3.6	1.9	421	-40 to +105	
STM32F103VG	1024	96	LQFP100	14x16-bit		16x12-bit	2x12-bit	80	3	2	2	3+2	1	1	1	2.0 to 3.6	1.9	421		
STM32F107VC	256	64	LFBGA100, LQFP100	7x16-bit		16x12-bit	2x12-bit	80	3	2	2	3+2	OTG	2		Yes	2.0 to 3.6	1.9		393
<b>STM32 F2 series - ARM Cortex™-M3 high-performance MCUs</b>																				
STM32F205RE	512	128	LQFP64, WLCSP64	12x16-bit, 2x32-bit	2x WDG, RTC, 24-bit downcounter	16x12-bit	2x12-bit	51	3	2	3	4+2	2	2	1	1.7/1.8 to 3.6	2.5	188	-40 to +105	
<b>STM32F207/217 line: 2x USB OTG (FS/HS1), camera IF, crypto/hash processor<sup>2</sup> - 120 MHz CPU</b>																				
STM32F207IF	768	128	UFBGA176	12x16-bit, 2x32-bit	2x WDG, RTC, 24-bit downcounter	24x12-bit	2x12-bit	140	3	2	2	4+2	2	2	1	Yes	1.8 to 3.6	2.5	188	-40 to +105
STM32F215VE <sup>2</sup>	512	128	LQFP100			16x12-bit	2x12-bit	82	3	2	3	4+2	2	2	1		1.8 to 3.6	2.5	188	
STM32F217IE <sup>2</sup>	512	128	UFBGA176			24x12-bit	2x12-bit	140	3	2	2	4+2	2	2	1	Yes	1.8 to 3.6	2.5	188	
<b>STM32 F3 series - ARM Cortex™-M4 mixed-signal MCUs with DSP and FPU</b>																				
STM32F303VC	256	48	LQFP100	9x16-bit, 1x32-bit	SysTick, 2x WDG, RTC	39x12-bit	2x12-bit	87	3	Up to 2x half duplex I <sup>2</sup> S	2	5	1	1		2.0 to 3.6	0.5	390	-40 to +105	
STM32F373RB	128	24	LQFP64	9x16-bit, 2x32-bit		8x16-bit/16x12-bit	3x12-bit	52	3		Up to 3x half duplex I <sup>2</sup> S	2	3	1	1		2.0 to 3.6	0.5		420
<b>STM32 F4 series - ARM Cortex™-M4 high-performance MCUs with DSP and FPU</b>																				
<b>STM32F401 line: USB OTG (FS), low power (11 µA typ. in Stop mode) - 84 MHz CPU</b>																				
STM32F401CC	256	64	WLCSP49, UQFPN48	6x16-bit, 2x32-bit	2x WDG, RTC, 24-bit downcounter	10x12-bit		36	3	2	3	3	1			1.8 to 3.6	1.7	140	-40 to +105	
STM32F401VC	256	64	LQFP100			16x12-bit		79	4	2	3	3	1		1		1.8 to 3.6	1.7		140
<b>STM32F429/439 line: 2x USB OTG (FS/HS1), camera IF, crypto/hash processor<sup>2</sup>, TFT LCD controller, SDRAM interface, dual-bank Flash - 180 MHz CPU</b>																				
STM32F427ZG	1024	256	LQFP144	12x16-bit, 2x32-bit	2x WDG, RTC, 24-bit downcounter	24x12-bit	2x12-bit	114	6	2	3	4+4	2	2	1	Yes	1.7 to 3.6	2.5	260	-40 to 105
STM32F429BG	1024	256	LQFP208			24x12-bit	2x12-bit	168	6 + 1 SAI	2	3	4+4	2	2	1	Yes	1.7 to 3.6	2.5	260	
STM32F429NG	1024	256	TFBGA216			24x12-bit	2x12-bit	168	6 + 1 SAI	2	3	4+4	2	2	1	Yes	1.7 to 3.6	2.5	260	
STM32F429BI	2048	256	LQFP208			24x12-bit	2x12-bit	168	6 + 1 SAI	2	3	4+4	2	2	1	Yes	1.7 to 3.6	2.5	260	
STM32F437Z <sup>2</sup>	2048	256	LQFP144			24x12-bit	2x12-bit	114	6	2	3	4+4	2	2	1	Yes	1.7 to 3.6	2.5	260	

ST and its partners offer a wide range of tools to help you develop applications:

- 15+ IDE (integrated development environment) amongst the most used in the developers' community (see diagram below)
- 25+ RTOS (real time operating system) and stack providers (see diagram below)



IDE solutions for the STM32, other solutions are: AIJI System, CooCox

HighIntegritySystems



Embedded software partners for the STM32, other partners are: Alpwise, ANDREA Informatique, ARCCORE, eForce, Embedded Solutions, IS2T, MicroControl, Micro Digital, Oryx Embedded, Tapko Technologies, YOGITECH











Many technical documents are available to start with the STM32, as well as free software libraries and examples fitting the most common requirements and more.

A collection of drivers for each peripheral is available with the CMSIS and peripheral library. This makes it easy to understand how an STM32 is working and how it fits in your design.

ST and its partners offer a wide range of middleware bricks, especially for communication: TCP/IP, USB, Bluetooth, crypto, and more. Some of these bricks implement standard specifications, such as USB or Bluetooth stacks, while others bring added value in specific areas such as industrial protocols with Profinet, Ethercat, and more.

Below is a selection of evaluation boards for STM32 MCUs: this selection presents boards for a first inexpensive hands-on experience of our MCUs (dimensions of the boards in the pictures are not to scale). For more information, see [www.st.com/stm32](http://www.st.com/stm32).

Part number	Description	Image
STM32-PRIMER	Complete Primer ready to use from Raisonance for easy evaluation and development with STM32 MCUs	
32F0308DISCOVERY	Discovery kit for STM32 F030 Value line - with STM32F030R8 MCU	

Part number	Description	Image
<b>32F072BDISCOVERY</b>	Discovery kit for STM32F072 line microcontrollers	
<b>STM32F3DISCOVERY</b>	Discovery kit for STM32F303xx microcontrollers	
<b>32L100CDISCOVERY</b>	Discovery kit for STM32L100 Value line - with STM32L100RC MCU	
<b>32L152DISCOVERY</b>	Discovery kit for STM32L151/152 line - with STM32L152RC MCU	
<b>STM32VLDISCOVERY</b>	Discovery kit for STM32F100 Value Line - with STM32F100RB MCU	
<b>32F401CDISCOVERY</b>	Discovery kit for STM32F401 line - with STM32F401VC MCU	
<b>32F429IDISCOVERY</b>	Discovery kit for STM32 F429/439 lines - with STM32F429ZI MCU	
<b>STM32100E-EVAL</b>	Evaluation board for STM32F100 (512KB Flash) Value Line MCUs	
<b>STM32429I-EVAL</b>	Evaluation board for STM32F429 line - with STM32F429x	
<b>STM32303C-EVAL</b>	Evaluation board for STM32F303xx microcontrollers	
<b>STM32439I-EVAL</b>	Evaluation board for STM32F439 line - with STM32F439NI MCU	



Part number	Description	Image
STM32401G-EVAL	Evaluation board for STM32F417 line - with STM32F417IG MCU	
STM32373C-EVAL	Evaluation board for STM32F373VCT6	
STM320518-EVAL	Evaluation board for STM32 F0 series - with STM32F051R8 MCU	

### STM32 development tools: STM32 Nucleo and STM32Cube™

ST is introducing two new hardware and software development platforms: the STM32 Nucleo and the STM32Cube.

STM32 Nucleo, the highly affordable STM32 boards, allows to try out new ideas and to quickly create prototypes on any STM32 MCU. Sharing Arduino™ connectors and ST Morpho headers, STM32 Nucleo boards can easily be extended with a large number of application related hardware add-ons. The STM32 Nucleo boards come with an integrated ST-Link debugger/programmer; no need for an external probe. The boards work with a wide range of development environments including IAR EWARM, Keil MDK, mbed, GCC-based IDEs (Atollic TrueStudio). STM32 Nucleo users have free access to the mbed online compiler, the mbed online C/C++ SDK and the developer community at mbed.org, allowing to build a complete application in only a few minutes. More at [www.st.com/stm32nucleo](http://www.st.com/stm32nucleo)

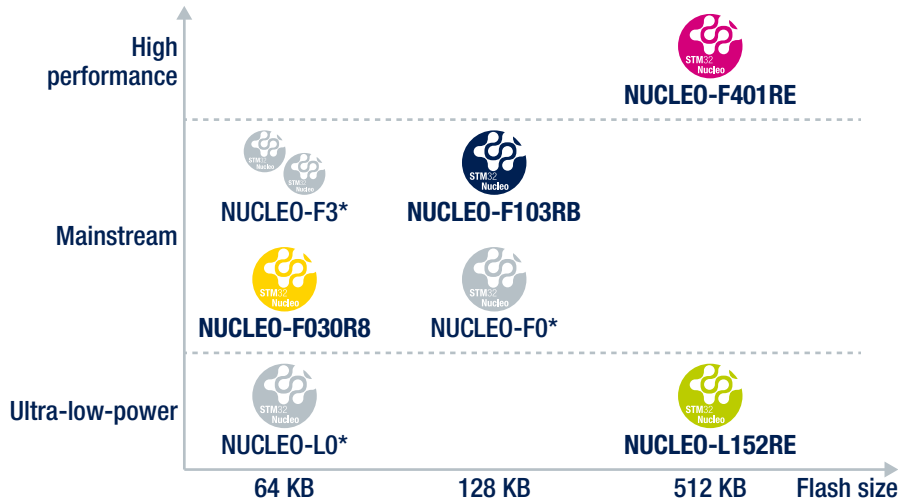

Note: \* support for STM32 L0, STM32 F3 and more STM32 F0 coming soon  
STM32 Nucleo portfolio

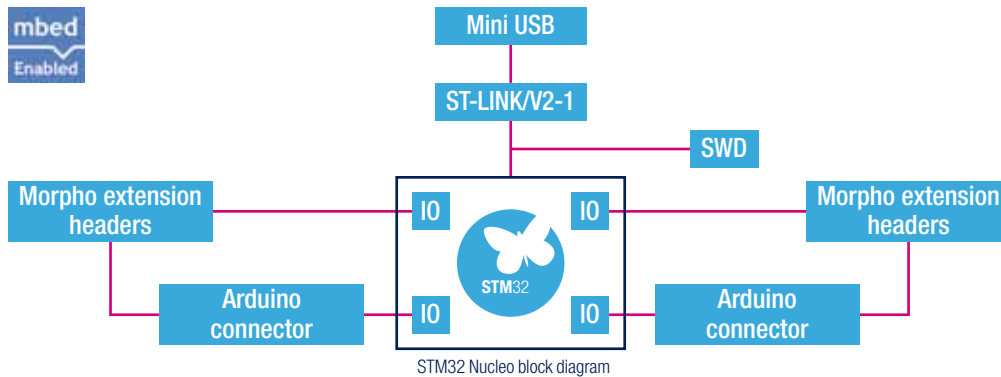
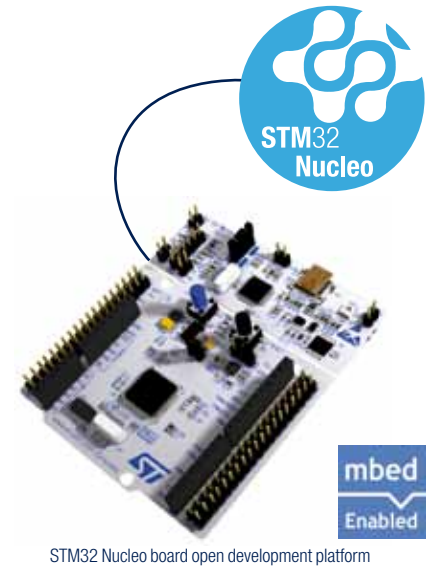

STM32Cube is a powerful new free design tool and software for its STM32 microcontroller portfolio. The new STM32Cube™ development platform comprises the STM32CubeMX graphical configurator and initialization C-code generator that provides step-by-step guidance for users and a set of rich embedded-software components that save integrating software from multiple sources. The software includes a new Hardware Abstraction Layer (HAL) that simplifies porting from one STM32 device to another. ST is also introducing the STM32CubeF4 firmware, with the middleware and HAL supporting, for the high-performance STM32 F4. Further releases will roll out during the year, more at [www.st.com/stm32cube](http://www.st.com/stm32cube)

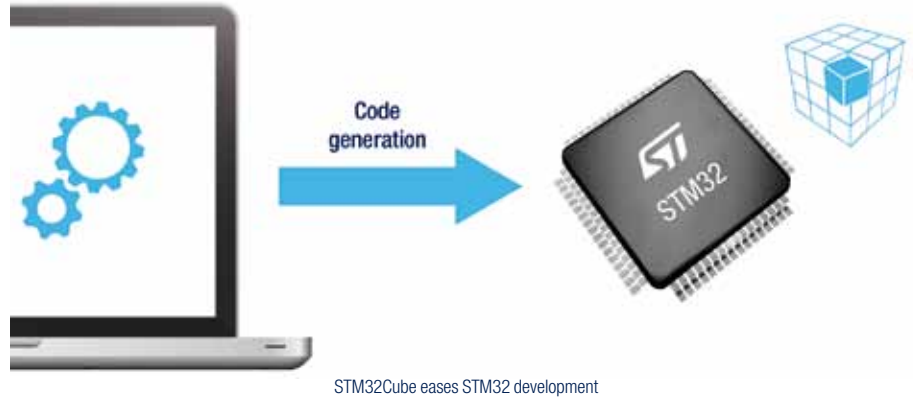

### STM32 dedicated Motor Control libraries

STM32 support tools are enhanced by a rich libraries set to develop any Motor Control application faster.

In this family, the STM32 PMSM FOC SDK v3.x is a Motor Control Software Development Kit (SDK) for 3-phase Permanent Magnet Synchronous Motors (PMSM) based on Field Oriented Control (FOC) supporting STM32F103, STM32F100, STM32F2xx, STM32F4xx, STM32F0xx and STM32F30x.

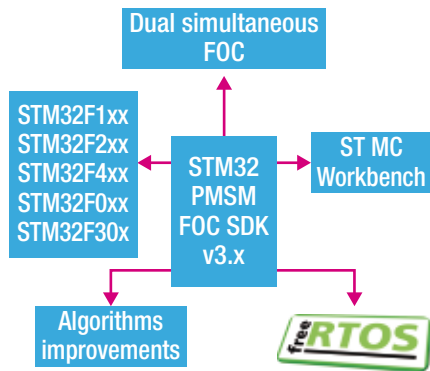

Key features of the the STM32 PMSM FOC SDK v3.x are:

- Single/Dual simultaneous vector control (FOC)
- Any combination of current reading topologies and/or speed/position sensors is supported
- Wide range of STM32 microcontrollers families supported
- Full customization and real time communication through PC software ST MC Workbench
- Wide range of motor control algorithms implemented for specific applications
- Application example based on FreeRTOS
- Increase code safety through
  - MISRA C rules 2004 compliancy
  - Strict ANSI C compliancy
  - New object oriented FW architecture (better code encapsulation, abstraction and modularity)

The partitioning below, shows how it is designed the ST MC FOC SDK (version 3.4), in order to understand how it is tailored for the different MCUs, making it possible to choose the best trade-off in terms of resources usage and the characteristics of the final application.

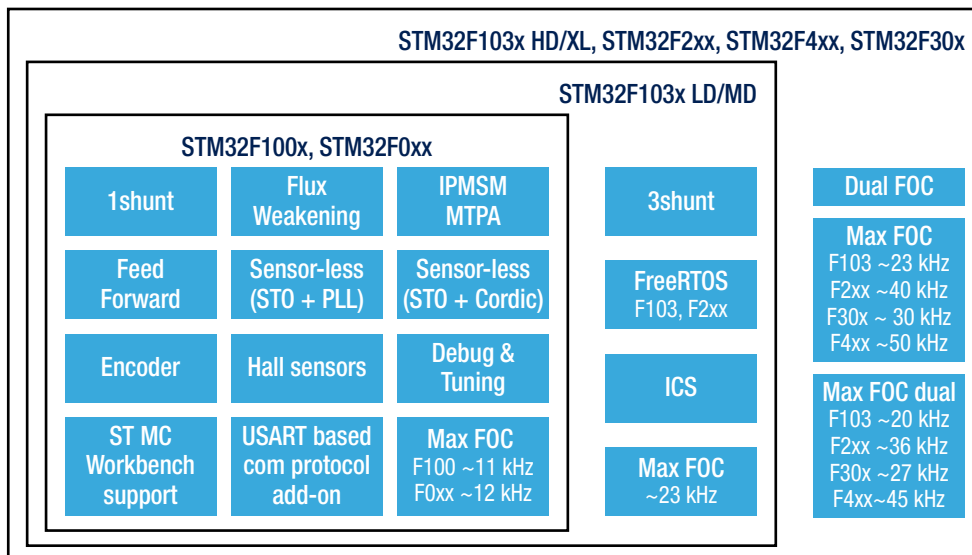

### ST Motor Control Workbench

The ST Motor Control Workbench is a PC software making faster the STM32 PMSM FOC firmware library configuration. Accordingly to the application needs, the user will set all the parameters and headers files through an intuitive PC GUI.

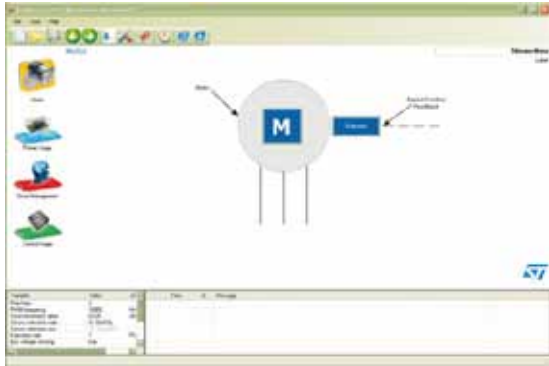

Motor

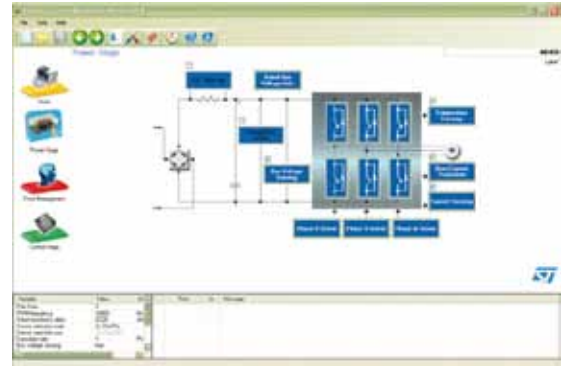

Power Stage

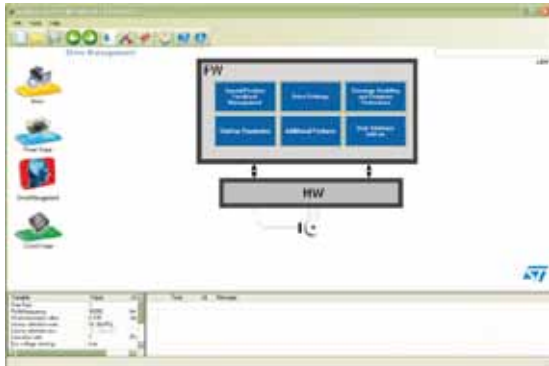

Drive Management

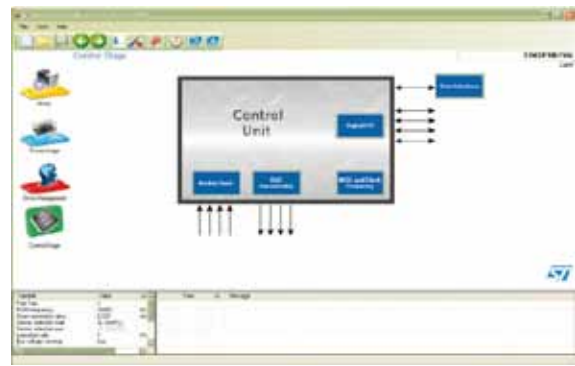

Control Stage

The ST Motor Control Workbench allows Real-time communication: for example, setting a speed ramp or send start/stop commands is possible from the GUI for first lab tests. Advanced tabs allow to fine tuning of parameters, i.e. PID control, as well as firmware debug, while it is possible to plot significant motor control variables, like target or measured motor speed, using the embedded virtual oscilloscope.



# ANALOG AND DIGITAL IO

## Digital inputs

Modern control systems are highly complex applications. The trend is to use as many integrated solutions as possible in such designs, either to increase the density or to reduce physical dimensions of the modules. Either way results in more stringent requirements regarding the total power dissipation of the module.

CLT devices form a new series of intelligent protected terminations designed for digital-input modules and proximity-sensor interfaces in industrial and building automation systems. Today's designers face the challenge of increasing the number of I/Os per volume unit and increasing the I/O-interface features. The CLT series offers highly robust EMC compliant solutions according to:

- Surge IEC 61000-4-5: 1 kV
- ESD IEC 61000-4-2: 15 kV
- EFT burst IEC 61000-4-4: 4 kV

Robustness is also a key parameter for CLT devices, including the CLT01-38S4, that operates with all types of sensor according to IEC 61131-2, type 1 and 3, with a 2.35 mA limited current, and type 2, using two inputs per sensor with the correct  $R_{REF}$ .

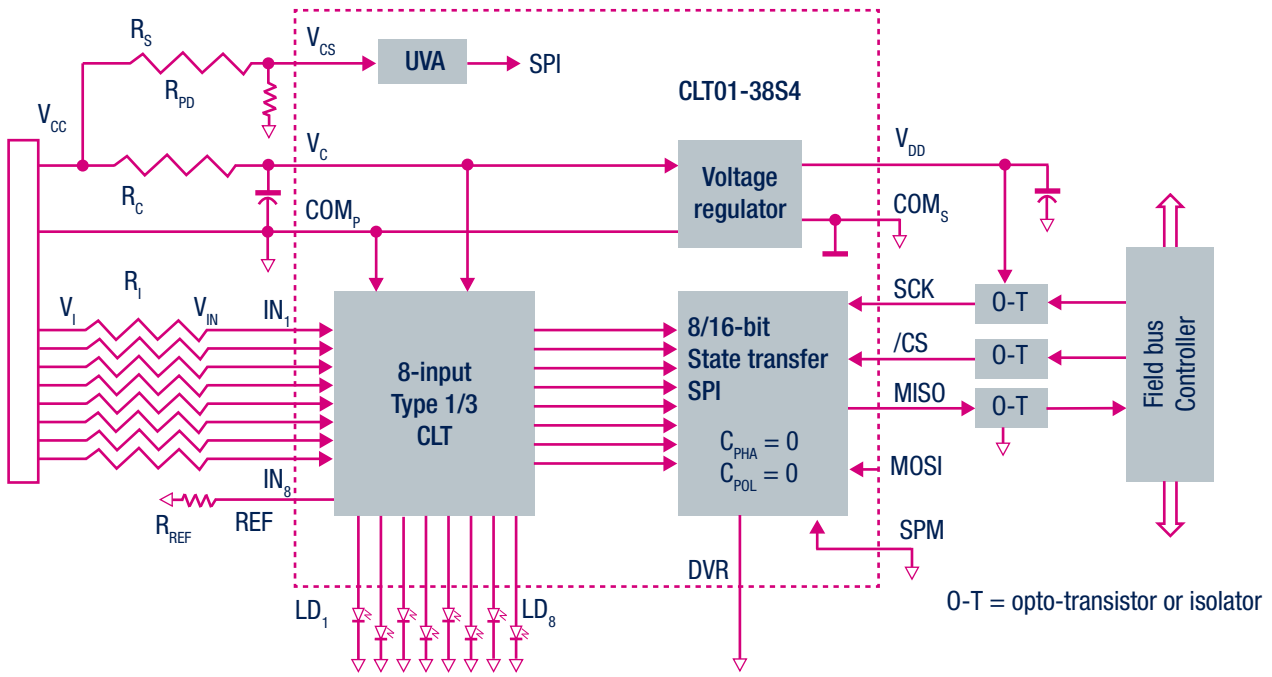



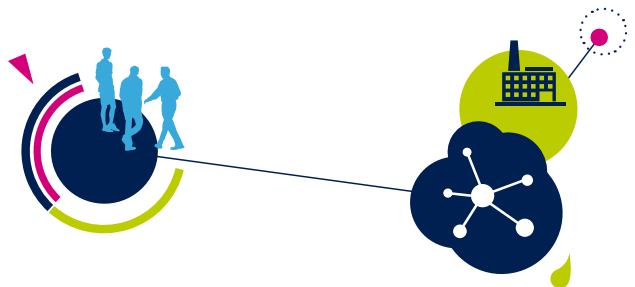

CLT01-38S4 wiring diagram



The CLT series and its related evaluation boards, as well as the basic documentation, is shown in the table below, together with the most important features of the devices. More information about current limiters is available at [www.st.com/protection](http://www.st.com/protection).

xCLT product	CLT3-4BT6	PCLT-2AT4	SCLT3-8BT8	CLT01-38S4
Number of inputs	4	2	8	8
Input IEC 61131-2	Type 1 and 3	Type 1, 2 and 3	Type 1, 2 and 3	Type 1, 2 and 3
Output type	Isolated	Isolated Non-isolated	Isolated Non-isolated SPI serialized transfer	Isolated Non-isolated SPI serialized transfer
Output drive	Opto transistor	Opto transistor CMOS compatible	Opto transistor Electromagnetic isolator CMOS compatible	Opto transistor Electromagnetic isolator CMOS compatible
Input current limiter	2.8 mA	2.5 to 7.5 mA	2.35 mA	2.35 mA
Current tolerance	25%	18%	10%	10%
Front-end LED status	Yes, using type 1	Yes	Yes	Yes
Surge level	> 1 kV	Type 3: 1 kV Type 2: 0.5 kV	> 1 kV	> 1 kV
ESD level	8 kV	15 kV	15 kV	15 kV
Package	TSSOP-20	TSSOP-14	HTSSOP-38	HTSSOP-38
Input data rate	10 kbit/s	10 kbit/s	40 kbit/s	400 kbit/s
Evaluation board	STEVAL-IPF008V1	STEVAL-IPF004V1	STEVAL-IPF007V1	STEVAL-IPF023V1
Application note	AN2527	AN2482	AN2846 and AN3031	-

Order code	Device series	Picture	Features
STEVAL-IPF008V1	CLT3-4B		With a front end display LED - type 1 operation
STEVAL-IPF004V1	PCLT-2A		Designed to pass EMC tests in opto and CMOS mode
STEVAL-IPF007V1	SCLT3-8		Designed to meet real environment conditions <ul style="list-style-type: none"> <li>• EMI proof above 4 kV EFT</li> <li>• With opto-transistor</li> </ul>
STEVAL-IPF023V1	CLT01		Designed to meet real environment conditions <ul style="list-style-type: none"> <li>• EMI proof above 4 kV EFT</li> <li>• With opto-transistor</li> <li>• 400 kbps input speed</li> </ul>

## Digital outputs

In this large family of products, we find intelligent power switches (IPS). These integrate a control part (logic interface, high-side drivers, and protection) with a power stage. IPSs are based on ST-patented technologies, including bipolar, multipower BCD and VIPower MO technologies. This provides increased system reliability, part count reduction, space saving and built-in protection, with smaller IPS devices that are housed in tiny, flat, no-lead plastic packages (DFN, QFN). The high thermal capacitance of the power packages such as PowerSO-36, PowerSSO24 and PowerSSO12 allows the absorption of high-energy pulses when an inductive load is driven without any external freewheeling diode. As an example, the block diagram below shows one of our latest IPSs, the VN808, designed in our proprietary VIPower technology.

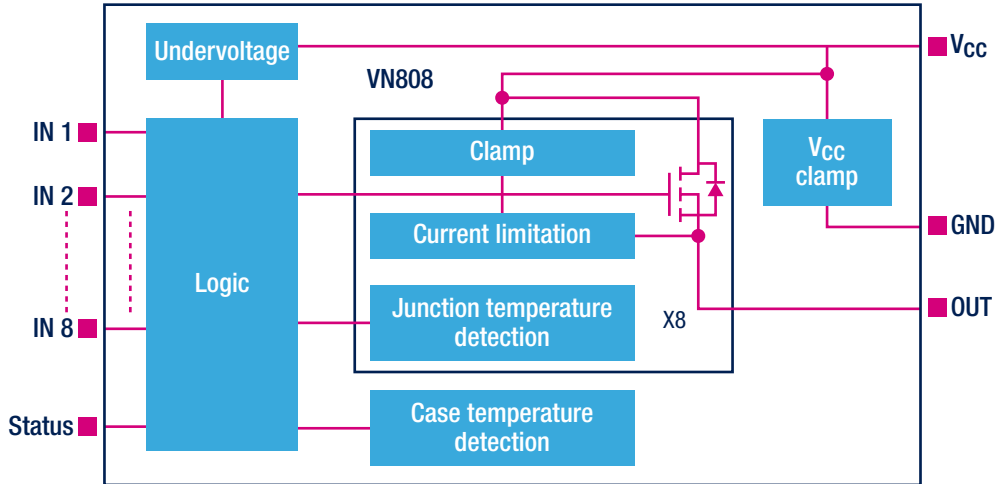

A recent introduction to the IPS family is the ISO8200B, a galvanic isolated 8-channel driver featuring a very low RDS(on) for the power stage. It contains 2 independent galvanic isolated voltage domains ( $V_{CC}$  for the power stage and  $V_{DD}$  for the digital stage). Additional embedded functions are loss-of-GND and loss-of-channels over-temperature protection and case over-temperature protection, undervoltage shutdown with hysteresis, reset function for IC output disable, overvoltage protection ( $V_{CC}$  clamping), direct and synchronous control mode, fast demagnetization for inductive loads, and ESD protection.

The IC is intended to drive any kind of load with one side connected to ground with 3.3/5 V compatible inputs. Active channel current limitation combined with thermal shutdown (independent for each channel) and automatic restart protect the device against overload and short circuits. In overload conditions, if the junction temperature exceeds the threshold, the channel involved is turned off and then automatically on again after the IC temperature decreases below the reset threshold. If this condition causes the case temperature to reach the threshold limit, TCR, the overloaded channel is turned off and only restarts when the case and junction temperature decrease below the reset thresholds. Non-overloaded channels continue to operate normally. An internal circuit provides an OR-wired unlatched common fault indicator signaling the channel over-temperature. The fault pin is an open-drain active-low fault indication pin.



ISO8200B device

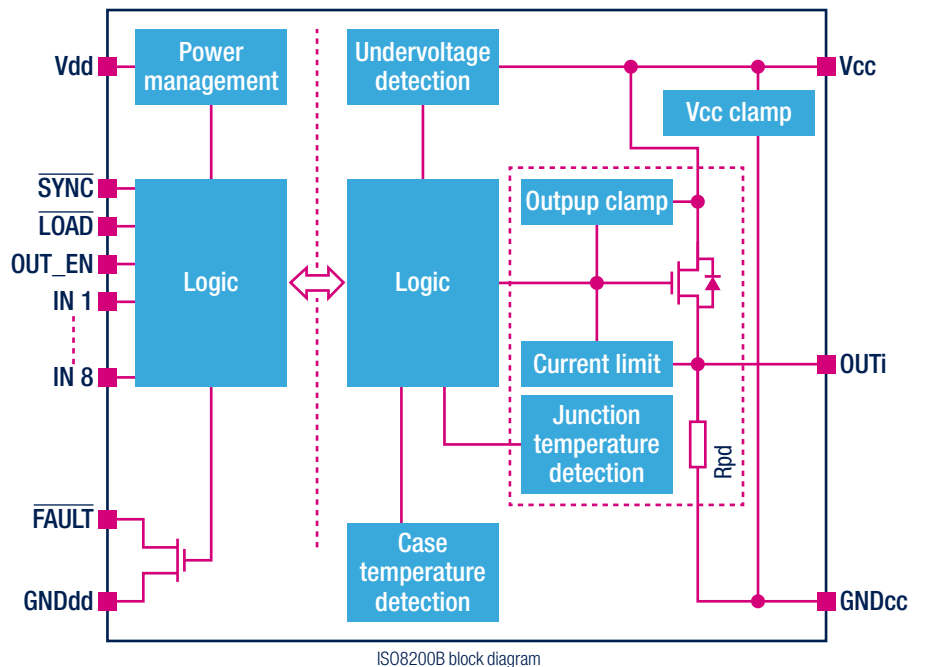

ISO8200B block diagram



## SOME SINGLE-CHANNEL IPSs

Part number	V <sub>CC</sub>	R <sub>DS(on)</sub> (Ω)	I <sub>OUT</sub> (A)	Technology	Package	Channels
TDE1737DP	8 to 50	-	0.5/Adj.	Bipolar	DIP-8	1 (low side)
TDE1747FP	10 to 60	-	0.45/Adj.	Bipolar	SO-14	1 (high side)
TDE1787ADP	6 to 60	-	0.3/Adj.	Bipolar	DIP-8	1 (high side)
TDE1798DP	6 to 50	-	0.5/0.7	Bipolar	DIP-8	1 (high side)
TDE1897RFTP	18 to 50	0.4	0.5/0.75	MultiBCD	SO-20	1 (high side)
L6370Q	9.5 to 50	0.1	2.5/Adj.	MultiBCD	QFN 48L 7x7	1 (high side)
L6375D	8 to 50	0.4	0.5/0.75	MultiBCD	SO-20	1 (high side)
L6377D	8 to 50	0.4	0.5/Adj.	MultiBCD	SO-14	1 (high side)
VN751PT/S	5.5 to 41	0.060	2/2.5	VIpower	PPAK/SO-8	1 (high side)

## SOME MULTI-CHANNEL IPSs

Part number	V <sub>CC</sub>	R <sub>DS(on)</sub> (Ω)	I <sub>OUT</sub> (A)	Technology	Package	Channels
VNI2140J	9 to 36	0.08	1.0	VIpower	PowerSSO-12	2
L6374	10.8 to 35	4.0	0.1	MultiBCD	SO-20	4
L6376	9.5 to 35	0.64	0.5	MultiBCD	PowerSO-20	4
VNI4140K	10.5 to 36	0.08	0.7	VIpower	PowerSSO-24	4
VNI4140K-32	10.5 to 36	0.08	1.0	VIpower	PowerSSO-24	4
VNQ860	5.5 to 36	0.27	0.25	VIpower	SO-20/PowerSO-10	4
VN808/-32	10.5 to 36	0.15/0.16	0.7/1.0	VIpower	PowerSO-36	8
VN808CM/-32	10.5 to 36	0.15/0.16	0.7/1.0	VIpower	PowerSO-36	8
VNI8200XP	45	0.11	0.7	VIpower	PowerSSO-36	8
ISO8200B	45	0.11	0.7	MultiBCD + VIpower	PowerSSO-36	8

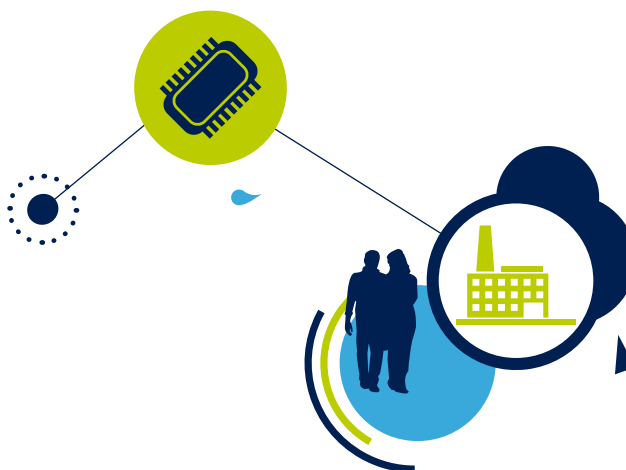

A new generation of IPS is being developed in our proprietary BCD8SP technology, making it possible to implement both high-side and low-side drivers. The first devices are the IPS4200L and IPS4200H, respectively low- and high-side 4-channel drivers.

The VN18200XP is an octal, high-side smart power solid-state relay, with a serial/parallel selectable interface on chip (8-/16-bit SPI interface for IC command and control diagnostics). The IC, built using ST's VIPower™ technology, is designed to drive any kind of load with one side connected to ground. Active channel current limitation combined with thermal shutdown, independent for each channel, and automatic restart, protect the device against overload. Additional embedded functions are loss-of-GND protection that automatically turns off the device outputs should ground be disconnected, undervoltage shutdown with hysteresis, power good diagnostics for valid supply voltage range recognition, output enable function for immediate power output on/off, and programmable watchdog function for MCU safe operation.

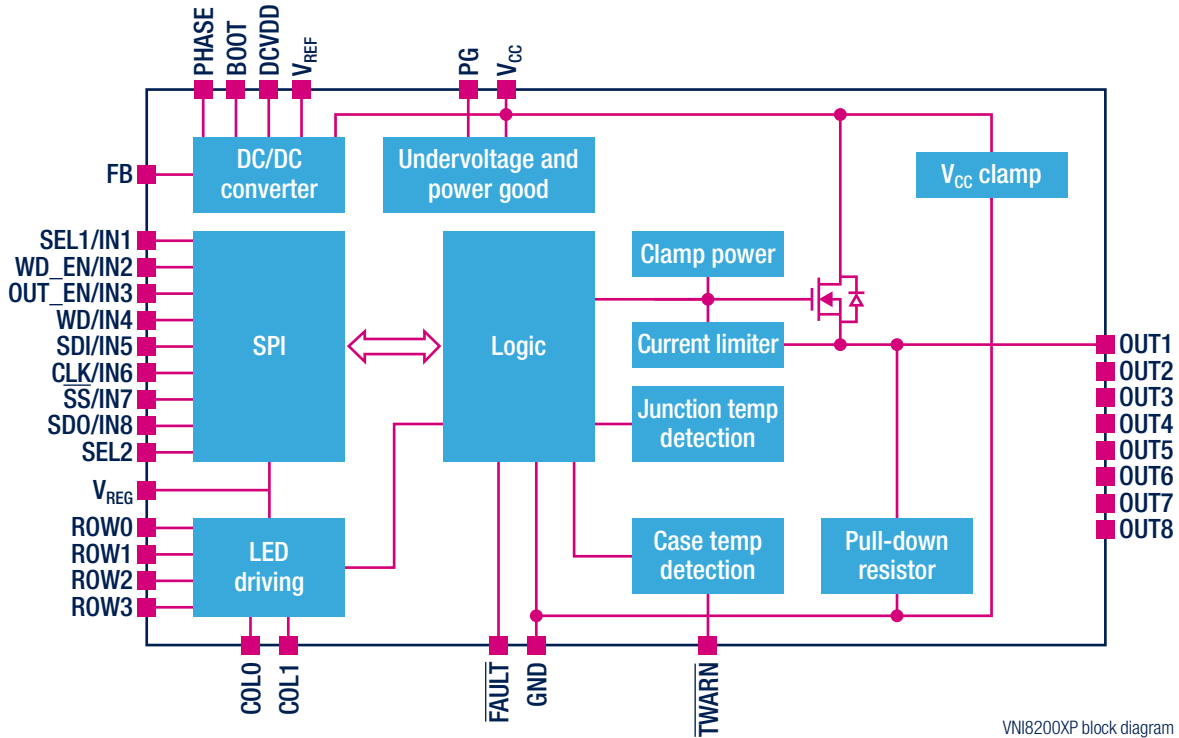







VN18200XP block diagram

IPS devices are designed to safely drive every kind of load in low-voltage applications (up to 55 V), handling data in and out of the microcontroller by means of status/input signals. IPS devices are designed to comply with the following international standards:

- IEC 61000-4-4 (electrical fast transient/burst)
- IEC 61000-4-2 (ESD, immunity test contact/air)
- IEC 61000-4-5 (surge test immunity requirements)
- IEC 61000-4-6 (current injection test)
- IEC 61131-2 (programmable controller, equipment requirements and tests)

Another important trend addressed in factory automation to achieve safety is the SIL (safety integrity level). Within our IPS family, SIL standards for functional safety are taken into account with the IPS160H, a high-side driver (65 V<sub>CC</sub> max) that is compliant with SIL-3 specification (devices within this level in the SIL specification are able to implement fail-safe systems, these being systems in which one failure does not cause an unsafe state). IPS devices come with evaluation boards available on Internet, and some examples are given below ([www.st.com/ips](http://www.st.com/ips)).

Order code	Device series	Picture	Features
STEVAL-IFP022V1	VNI8200XP		To provide a user-friendly way to test the VNI8200XP's functionality, a GUI (graphic user interface) interface is also developed and associated to this board. To use the GUI it is necessary to connect the STEVAL-IFP022V1 demonstration board to a PC by using a communication board (part number STEVAL-PCC009V2). The STEVAL-IFP022V1 demonstration board meets EFT standard requirements IEC 61000-4-2, IEC 61000-4-4, IEC 61000-4-5.
STEVAL-IFP001V1	VN808CM		The STEVAL-IFP001V1 is compliant with international electromagnetic compatibility (EMC) specifications as well as EMC immunity proof 4 kV level EFT (IEC 61000-4-4), and 2 kV voltage surge (IEC 61000-4-5), and has been tested at different typical ambient temperatures. It is suitable for use in programmable logic controllers to produce the related digital outputs according to IEC standards.
STEVAL-IFP006V1	VN4140K		Suitable for use in programmable logic controllers (PLCs) as well as to drive generic loads which require up to 0.7 A of nominal current (the typical current limitation is 0.7 to 1.7 A).
STEVAL-IFP010V3	VNI2140J		This tool evaluates the VNI2140J's features, in particular embedded self-protection, power-handling capabilities, operation and diagnostic feedback, thermal behavior and conformity to EMC immunity standards.
STEVAL-IFS006V2	TDE1708DFT		Inductive proximity switch application based on the principle of metal body detection using the eddy current effect on the HF losses of a coil. The design consists of a single transistor HF oscillator, an ST7LITEUS5 microcontroller, an intelligent TDE1708DFT power switch, and a SPT01-335DEE triple Transil™ array.
STEVAL-IFP015V2	ISO8200B		The STEVAL-IFP015V2 demonstration board works in combination with the STEVALPCC009V2 or STEVAL-PCC009V1 interface board to allow evaluation of all the features of the ISO8200B device. A large GND area on the printed circuit board has been designed to minimize noise effects and ensure good thermal performance.

Some other IPS devices will be treated in the field layer section, as they are used as industrial transceiver ICs for IO-Link and SIO (Standard IO) mode.

## Analog IO Amplifiers and comparators

ST's op amps enhance the signal chain by being perfect companion chips to ST's microcontrollers and sensors. Below a first overview of these products, further details are available in the signal conditioning paragraph at pages 47 and 48.



### PORTFOLIO HIGHLIGHTS

- High precision Op-Amps
- High Speed Comparators
- High-Side Current Sensing Amplifiers
- Micropower
- 5 V and 16 V CMOS technology
- Tiny DFN/QFN packages

### Best precision micropower op-amp

ST's TSZ121 zero drift CMOS amplifier is the first member of the TSZ12 series of high-precision op amps featuring very low offset voltages with virtually zero drift over time and temperature. The TSZ121 is ideal for sensor interfaces, sensing current on very low resistance shunts and driving analog-to-digital converters, while minimizing the power consumption.



#### FEATURES

- Low offset  $V_{IO}$ : 5  $\mu$ V max
- $dV_{IO}/dT = 30$  nV/ $^{\circ}$ C max
- Operating range: 1.8 to 5.5 V
- Temperature range: -40 to +125  $^{\circ}$ C
- 40  $\mu$ A (typ at 5 V) / GBW 400 kHz
- Low bias current: 1 pA
- Rail-to-rail input/output
- High ESD protection: 4 kV HBM
- Tiny SC70/SOT23-5 packages

### High-speed comparator

ST's TS3011 single comparator achieves a propagation delay of 8 ns while consuming only 470  $\mu$ A of supply current at 5 V, which is 50% lower than other solutions in the market. The TS3011 addresses applications where fast response time is critical such as threshold detectors/discriminators, high-speed sampling, or zero-crossing detectors.



#### FEATURES

- Propagation delay: 8 ns
- Low current consumption: 470  $\mu$ A
- Rail-to-rail input
- Push-pull output
- Supply voltage: 2.2 to 5 V
- Temperature range: -40 to +125  $^{\circ}$ C
- ESD tolerance: 2 kV HBM
- SOT23-5 and SC70-5 packages

## DATA COMMUNICATION INTERFACE ICs

A PLC (or any modern control system) interfaces with several kinds of network depending on the overall system dimensions.

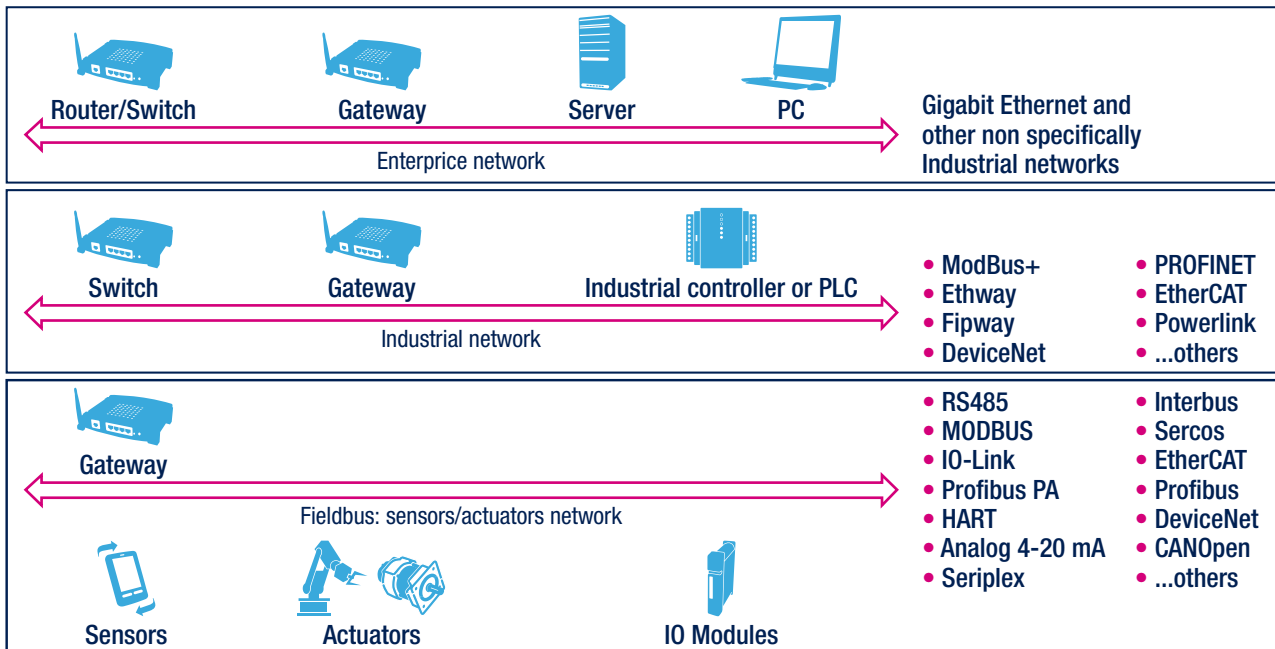

As can be seen from the diagram, there are many different networks. The different protocols developed over the years by consortiums, associations and private companies have become standard networks, sometimes complementing each other, or more often alternatives to each other. More at [www.st.com/communication](http://www.st.com/communication).

This section only covers the communication interfaces, while the implementation of the most common protocols in the industrial arena is part of the field layer section, in which the various industrial Ethernet stacks are enabled through our most advanced MCUs.

In this complex world, ST is positioned as a key partner in several associations and as a solution provider, with a very wide offer:

- I/O and network interface ICs
- Programmable transmitters
- Ethernet transceivers
- LAN adapters
- Routers and switches
- Data storage ASICs
- Power management ICs
- Dedicated circuits for Ethernet interfaces
- Powerful ARM Cortex MCUs
- Modem circuits
- ASI circuits
- Protection devices
- Wireless modules
- High-performance transceivers for sub-GHz applications

These last devices are finding a place in the industrial monitoring field and are addressed by our SPIRIT1:

- Frequency bands: 169, 315, 433, 868, 915, 920 MHz
- Configurable data rate from 1 to 500 Kbit/s
- SPI interface
- Supply voltage: 1.8 to 3.6 V
- Modulation schemes: 2-FSK, GFSK, MSK, GMSK, OOK, ASK
- Suitable for systems targeting compliance
  - Wireless MBUS standard
  - ETSI EN 300 220, FCC CFR47 Part 15, ARIB STD-67
- Output power: -36 to +11 dBm, in 0.5 dB steps
- Excellent receiver sensitivity: -120 dBm (1.2 Kbit/s – 169 MHz)
- Adjacent channel selectivity: 55 dB at 12.5 kHz channel spacing (1% PER – 20-byte packet length)
- Integrated SMPS allows very low power consumption
- Integrated packet handler
  - Support for automatic acknowledgment, retransmission, low duty cycle protocol and timeout protocol
- Automatic clear channel assessment (CCA) engine
  - Channel access mechanism, based on the rule listen-before-talk systems; embedded CSMA/CA protocol
- Fully-integrated ultra-low-power RC oscillator
- AES 128-bit encryption coprocessor for secure data transfer
- Frequency hopping under MCU control
  - Calibration can be made each time the MCU changes frequency or MCU can save and restore calibration data to make the frequency hopping faster
- Separate 96-byte Rx/Tx FIFOs
- Supports automatic antenna selection through an integrated antenna diversity switching mechanism



The application diagram is shown below.

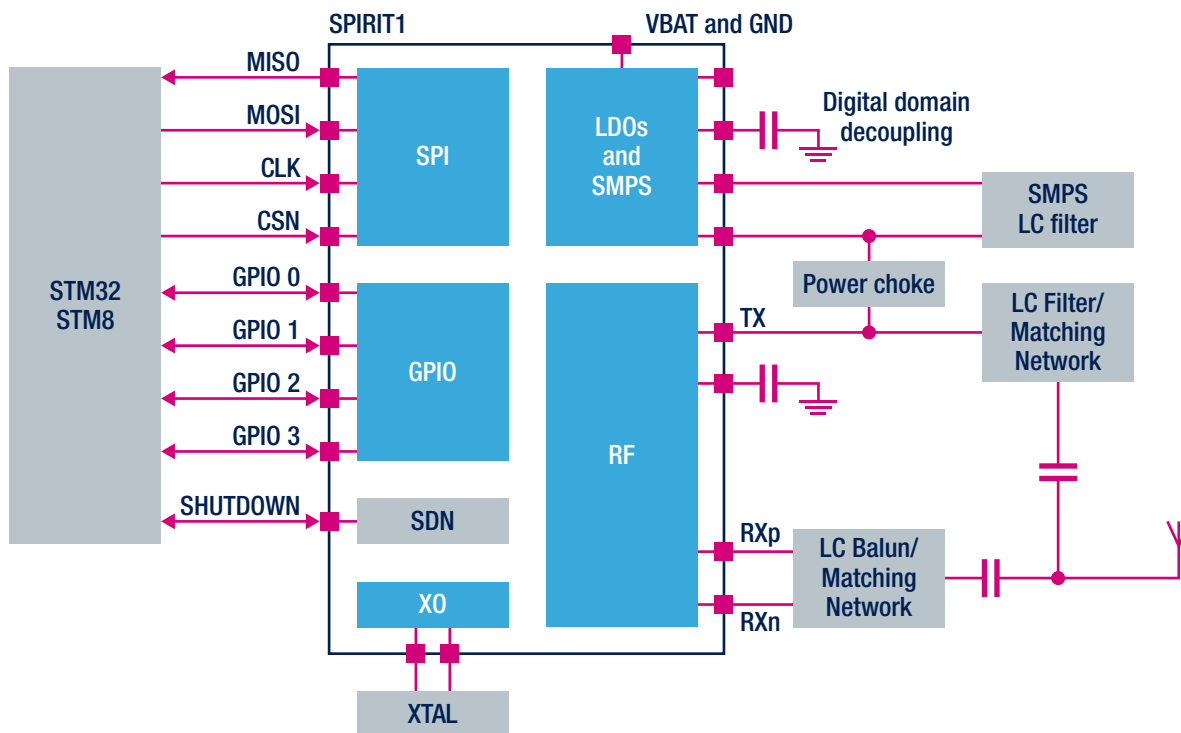

## USB transceivers and interfaces

ST's USB interface family includes high-speed USB OTG ULPI transceivers, full speed OTG transceivers and USB charger detection interfaces. They provide a complete solution to connect a digital USB-OTG and ULPI controller to the physical universal serial bus.

For example, the diagram below shows a typical application circuit using the STUSB03E.

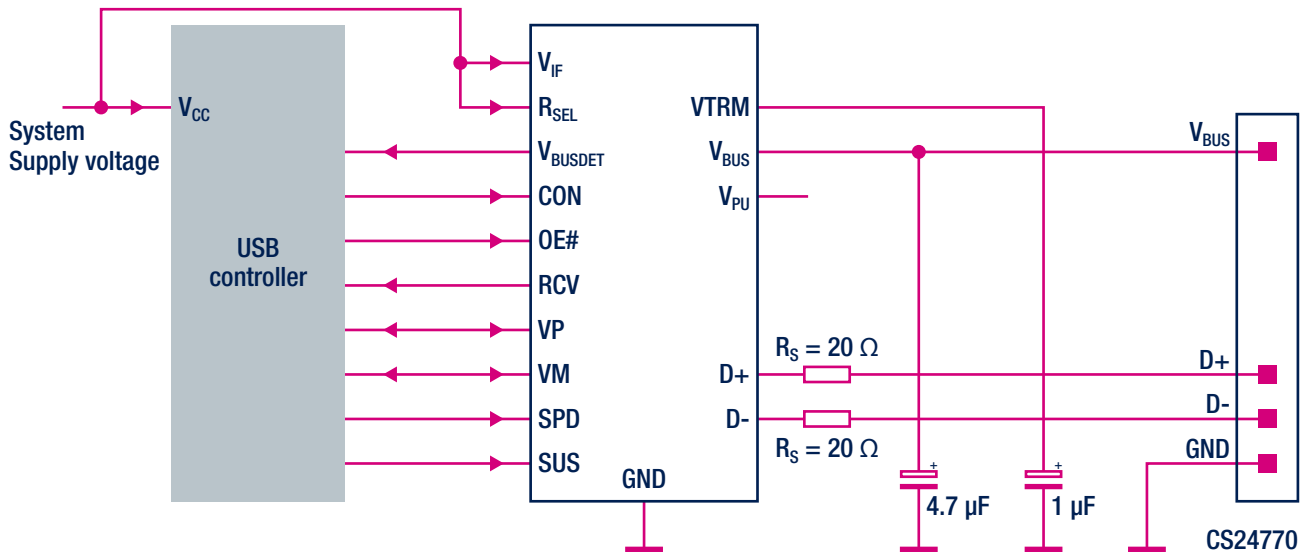

The STUSB03E is a single-chip transceiver that complies with the physical layer specifications of the Universal Serial Bus (USB) v2.0 standard. It has an integrated 5 V to 3.3 V regulator which allows direct powering from  $V_{BUS}$ . The transceiver has an integrated voltage detector to detect the presence of VBUS and features an internal D+ pull-up resistor implemented in accordance with the 27% resistor ECN.

## Ethernet primary protection

26

For advanced protection devices, the SLVU2.8 series has been designed to protect Ethernet lines. Their low capacitance makes them compatible with gigabit Ethernet.

In this family, the SLVU2.8-4A1 is designed to be compatible with gigabit Ethernet and gigabit PoE by using two SO-8 packages, and can be used on 10/100 Mbit/s Ethernet with a single device. Surge capability is compatible with IEC 61000-4-5 class 2 (1 kV, 42  $\Omega$ , 24 A).

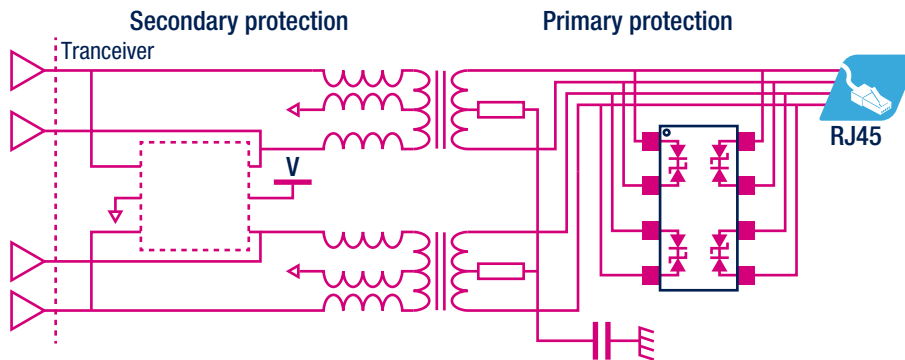

The diagram shows use the SLVU2.8-4A1 implementing a 10/100 Mbit/s Ethernet protection.

## RS-485/RS-232 protection

The following table presents some examples in decreasing complexity of dedicated ICs, such as the ST485Ex, a family of  $\pm 15$  kV ESD protected, low-power RS-485/RS-422 transceivers, for industrial applications ([www.st.com/interface](http://www.st.com/interface)).

Part number	Temperature range (°C)	Supply voltage(V)	Data rate min (Mbit/s)	Communication standard supported	Number of nodes	Number of drivers/receivers	Package
ST485EBDR	-40 to 85	5	5	RS485, RS422	256	1/1	S0-8
ST485EXDR	-55 to 125	5	5	RS485, RS422	256	1/1	S0-8
ST232EB	-40 to 85	4.5	230 (Kbaud)	RS232	-	2/2	S0-16, TSSOP 16



## SERIAL REAL-TIME CLOCK (RTC) ICS, RESET AND SUPERVISOR ICS

### Widest portfolio of RTC offers unlimited designs solutions

In applications where the clock must not drift, and time has to be kept for very long periods when unplugged, with minimal backup battery, a standalone RTC is significantly better than an embedded RTC in the MCU. An extended range of products with the latest technological innovations is available, including ultra-low-power devices, embedded crystals, analog and digital calibration and automatic temperature compensation. RTC functions include programmable alarm, battery switchover and many useful supervisory functions that enhance the application's reliability: oscillator fail detect, battery low detect, early power fail warning, reset, watchdog, and more ([www.st.com/rtc](http://www.st.com/rtc)).

### Reset and supervisor ICs keep applications running and under control

ST's portfolio of microprocessor supervisors and reset ICs are designed to keep your application processor under control and your application running. Our product portfolio of microprocessor supervisors and reset ICs ranges from basic, single-voltage resets, to smarter resets with a watchdog or an early power-fail detection function. We also offer highly-integrated devices that include reset, battery switchover and tamper-detect functions ([www.st.com/reset](http://www.st.com/reset)).

## RTC, RESET AND SUPERVISOR KEY PRODUCTS

Family	Sub-families	Parts	Key features	Applications
RTC	Low Power	M41T6x	Low standby current World's smallest RTC with crystal Small packages	Portable HMI
	Enhanced industry-standard	M41T81S M41T00S M41T01 M41T80 M41T11 M41T82/83/93 M41T00CAP	Automatic battery switchover Analog calibration Embedded crystal	Sub-metering HMI
	Highly-integrated	M41ST85W M41T94 M41T00AUD M41ST87W	Embedded NVRAM Internal and external RAM clear MCU supervising functions Tamper detect with timestamp	PLC Local Control Servers Data Storage Security



## MEMORIES

### Compact non-volatile memories

ST offers a wide range of non-volatile memories. The serial EEPROM family ranges from 1 Kbit to 2 Mbits and offers different serial interfaces: I<sup>2</sup>C, SPI, Microwire. The wide range of products is also automotive compliant, and very thin packages are available for applications where space is critical.

NVRAMs are battery-backed SRAMs that range from 16 Kbits to 32 Mbits, housed in DIP packages that include a battery, or surface-mount SOIC packages that allow for a SNAPHAT replaceable battery. Timekeeping and clock functions are also available ([www.st.com/memories](http://www.st.com/memories)).

Family	Sub-families	Part	Key features	Applications
Serial EEPROM	Application specific serial EEPROM	M342xx	Two EEPROM in a single package 4 and 18 Kbits	Portable HMI HMI PLC Local control Servers Data storage
		M34Exx	Serial presence detect (SPD) for DRAM modules 2 and 4 Kbits	
		M34F04	Half array write protect 4 Kbits	
		M35B32	Fast write operations 32 Kbits	
	Standard serial EEPROM	M24 series	I <sup>2</sup> C, with densities ranging from 1 Kbit to 2 Mbits, and a bus speed of 1 MHz or 400 kHz	
		M95 series	SPI, a faster bus that features a chip select input, with densities ranging from 1 Kbit to 2 Mbits, and a bus speed from 2 MHz to 20 MHz (depending on V <sub>CC</sub> )	
M93 series		Microwire, a legacy bus, with densities ranging from 1 Kbit to 16 Kbits		
NVRAM	ZEROPOWER	M48Zxx	ST's ZEROPOWER products integrate low-power SRAMs with a power-fail control circuit and a long-life lithium battery (available in CAPHAT or SOIC plus SNAPHATS packages). From 16 to 256 Kbits	
	Battery Options	M4Zxx-BR00SH	Two SNAPHATS packages (compatible with SOIC) which embed 48 or 120 mAh lithium batteries	

## POWER SUPPLIES

### Focus on industrial DC-DC converters

ST's power management devices enable energy-saving, high-power density and lower standby power design solutions. Our product portfolio includes highly-integrated AC-DC converters, switching DC-DC converters, linear voltage regulators, battery management ICs, LED drivers, photovoltaic ICs, MOSFET and IGBT drivers, motor drivers and more. These integrated solutions reduce the design cycle and ST's eDesignSuite ([www.st.com/edesign](http://www.st.com/edesign)) allows you to rapidly select and simulate the optimal configuration for your power management design, bringing a further advantage in time-to-market ([www.st.com/powermanagement](http://www.st.com/powermanagement)).

Matching the requirements of the industrial market, ST provides a complete family of step-down monolithic DC-DC converters with an input voltage range compliant to 24 V buses, and able to provide a continuous output current up to 3 A with high switching frequency (up to 2 MHz). A full set of protection features is embedded (overcurrent, overvoltage, over-temperature) to increase the MTBF and reduce the number of external components ([www.st.com/dcdc](http://www.st.com/dcdc)).

ST's DC-DC converters for industrial buses offer a wide choice of input voltage ranges (VIN\_max from 38 V to 61 V) and features. The new 61 V series (L7987/L) has been designed to provide maximum reliability in fail-safe applications.

The new synchronous DC-DC converter for industrial applications, the L6986, is the best choice when efficiency is of prime importance, both at full load (thanks to synchronous rectification) and at light load (thanks to the low standby consumption). Evaluation boards are available upon request.

There are multiple package options, all offering compactness and high thermal performances to fit different applications.



VFQFPN8 3x3

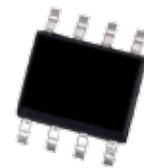

HSOP exposed pad



HTSSOP16 (R<sub>TH</sub> = 40 °C/W)

The following table orders this wide offering according to the different voltage bus levels, while some examples are provided further on.

Voltage bus range	Device family	Maximum output current	Synchronous rectification	Low consumption at light load	Package
4.5 to 38 V	L7985/6	2/3 A	No	No	HSOP8, VFQFPN10-3x3
4 to 38 V	L6986	2 A	Yes	Yes	HTSSOP16
5.5 to 48 V	ST1S14	3 A	No	No	HSOP8
4.5 to 61 V	L7987/L	2/3 A (with adj. current limit)	No	No	HTSSOP16

### L7987/L FEATURES

- 4.5 to 61 V input voltage range
- up to 3 A DC output current (2 A for L7987L)
- Adjustable peak current limit
- Adjustable switching frequency (250 kHz to 1.5 MHz) with synchronization capability
- Adjustable soft start
- Power good

### L6986 FEATURES

- 4 to 38 V input voltage range
- up to 2 A DC output current
- Synchronous rectification
- Very low quiescent current (~30  $\mu$ A typ.)
- Adjustable switching frequency (250 kHz to 2 MHz) with synchronization capability
- Adjustable soft start
- Power good with adjustable delay

### Linear voltage regulators

ST offers fixed and adjustable output linear regulators featuring an optimal combination of low dropout voltage, quiescent current, transient response and low noise. They are ideal for battery-powered applications (i.e. industrial hand-held equipments) where both optimum heat dissipation and small dimensions are key factors.

ST's series of low quiescent current LDO regulators is ideal for portable consumer and battery-powered applications where they extend the application's battery lifetime and keep good dynamic performance, all in a small footprint. Package options include the SC70, SOT666, CSP 4 bumps, DFN6L-1.2x1.3 and DFN6L-2x2

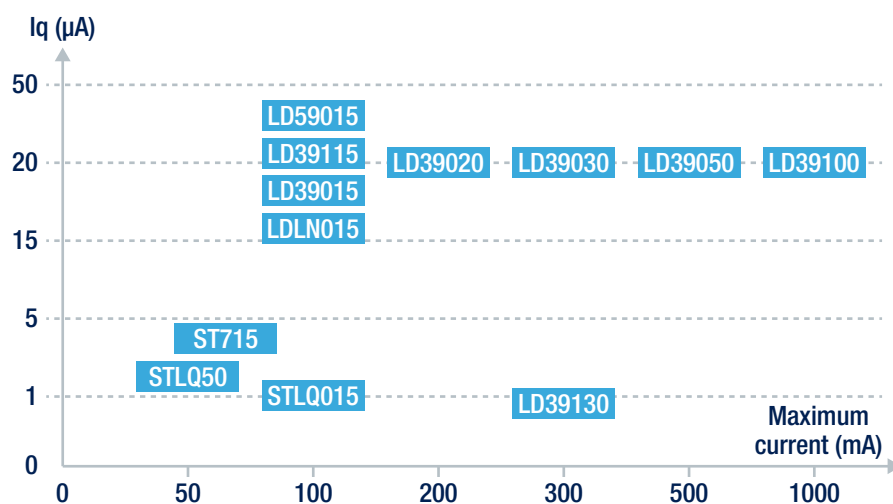

The new LD39200, is a high PSRR, ULDO with reverse current protection:

- Input voltage: from 1.25V to 6 V
- Output current: 2 A
- 1% output voltage accuracy at 25 °C
- Ultra low drop voltage: 200 mV at 2 A
- Fixed and adjustable Vout from 0.5 V
- High PSRR: 70 dB at 1kHz
- Fast transient response
- Enable and power good pins
- Reverse current protection
- Package: DFN 6L- 3x3 mm, DFN 8L 4x4

Finally, the new LDFM, LDF series, are the new, very low drop linear regulators:

- Input voltage: from 2.5 V to 16 V
- Output current: 0.5 A and 1 A
- Very low dropout voltage: 300 mV at 500 mA output current
- Low quiescent current: 200  $\mu$ A at full load
- Wide output voltage range choice: ADJ ( $V_{ref} = 0.8$  V) or fixed from 0.8 V to 12 V
- Logic controlled enable pin
- Power good function
- Stable with low ESR ceramic capacitors

## eDesignSuite development tool

Power supply ICs and not only, strongly benefit from our online development tool, conceived to build a design since the very first go. From ST's product selector to applications' design is possible in few steps with our eDesignSuite 7.1.0. ICs or better, applications, around this tool are:

- Power Supply
- LED driving
- Photovoltaic
- Battery Charger



www.st.com/edesignsuite



Specification page

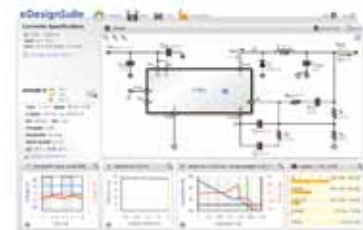

Circuit page

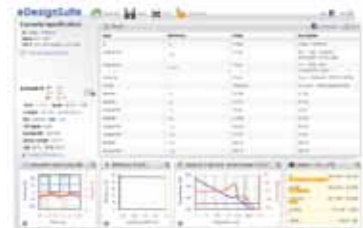

BOM page



Power losses page

### Start your new design from time 0:

- Go to [www.st.com/edesignsuite](http://www.st.com/edesignsuite)
- Register to get your free login and password
- Now start creating a new project from choosing your application scope
- Only high level specifications are needed, in terms of IO and selected ICs



### What can you get?

- Fully and interactive Bill of Material
- Definitive application schematics
- Circuit diagrams and analysis: Simulation, Efficiency, Bode diagrams, losses

## PROTECTION DEVICES

### Power and data line protection

In harsh factory automation environments, protection devices are the key to system reliability. ST offers a wide range of protection devices dedicated to power lines or data lines. More at [www.st.com/protection](http://www.st.com/protection)

### Power lines

Overvoltages and glitches appearing on power mains are modeled by the IEC 61000-4-5 international standard, also known as 8/20  $\mu$ s current waveform. Able to protect up to 500 A (8/20 $\mu$ s), the STIEC45 series is the ideal surge suppressor solution for factory automation power lines.

Order code	VBR @IR				VCL @IPP 8/20 $\mu$ s, 1.2/50 $\mu$ s	
	Min.	Typ.	Max.		Max.	
	V			mA	V	A
STIEC45-24AS	26.7	28.2	29.5	1	42	500
STIEC45-26AS	28.9	30.3	31.9	1	45	500
STIEC45-27AS	30	31.6	33.2	1	47	500
STIEC45-28AS	31.1	32.6	34.3	1	49	500
STIEC45-30AS	33.3	35	36.8	1	55	500
STIEC45-33AS	36.7	38.6	40.6	1	59	500

As well as the robust and reliable performances during voltage surges, ST's discrete TVS (transient voltage suppressors) exhibit an excellent power derating versus temperature. As an example, ST's SM15T series (1500 W, 10/1000  $\mu$ s) operates at full performance up to 115 °C.

Peak pulse power dissipation versus initial junction temperature (printed circuit board)

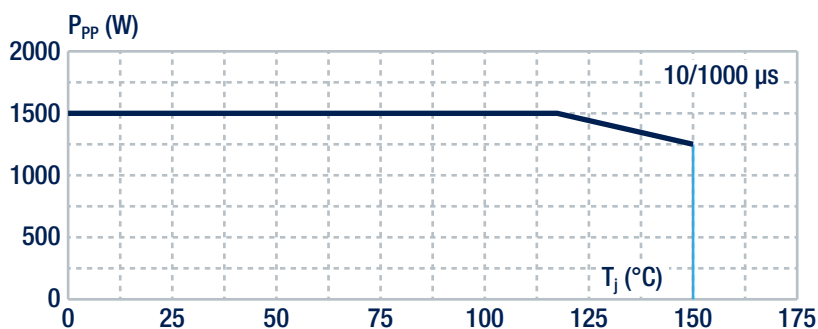

ST's large portfolio of EOS power 10/1000  $\mu$ s transient voltage surge suppressors (TVS)

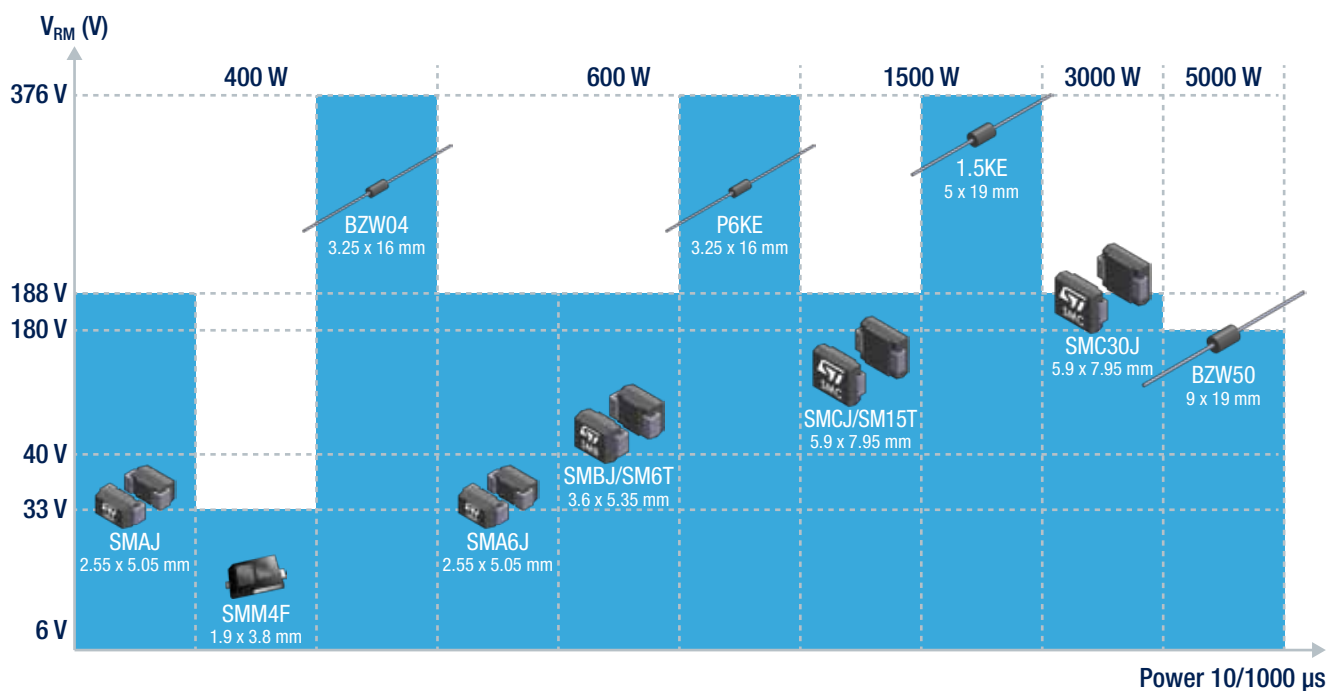

## Data lines

Communication buses, with long wire lengths, are particularly sensitive to electrostatic discharge (ESD). ST proposes multiline solutions in a single package, with various parasitic capacitance and voltage compromises, to address a wide range of industrial communication interfaces as shown below.

### ASI interface

Actuator and sensor Interface

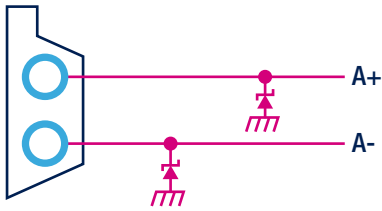

**SMM4F33A**  
ESD with +/- 30 kV contact

### Seriplex interface

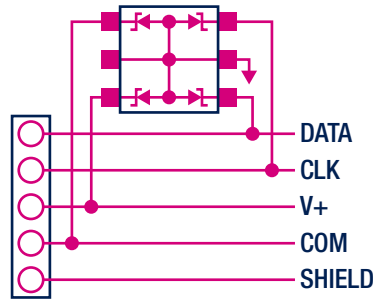

**ESDA14/25xx**  
ESD protection in SOT666/323/23

### RS-232 interface

Modbus®

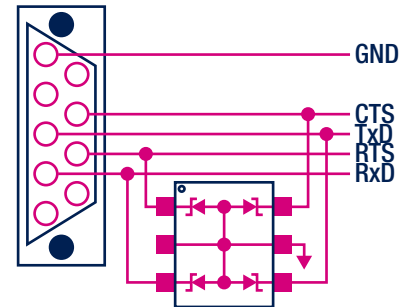

**ESD6V1/14/25xx**  
ESD protection in SOT666/323/23

### RS-422 and RS-485 interface

Modbus®, Modbus Plus™, PROFIBUS®

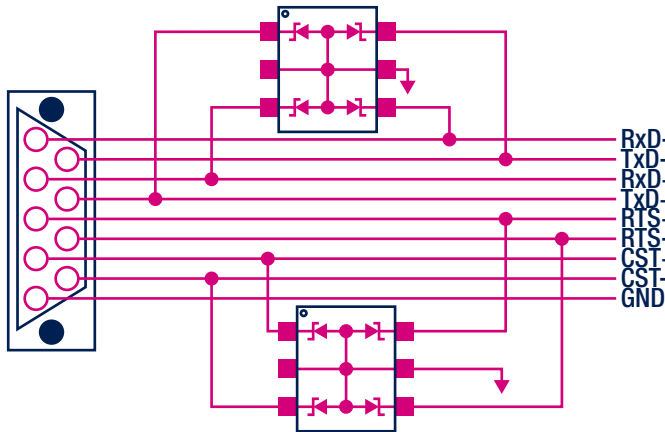

**ESDA6V1/14/25xx**  
ESD protection in SOT666/323/23

### CAN interface

CANopen, DeviceNet™

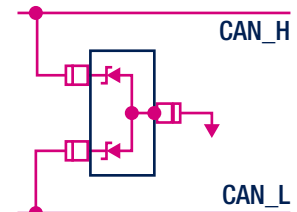

**ESDA5V1L/6V1L/ESDALC6V1**  
ESD protection in SOT666/SOT23

### Ethernet protection

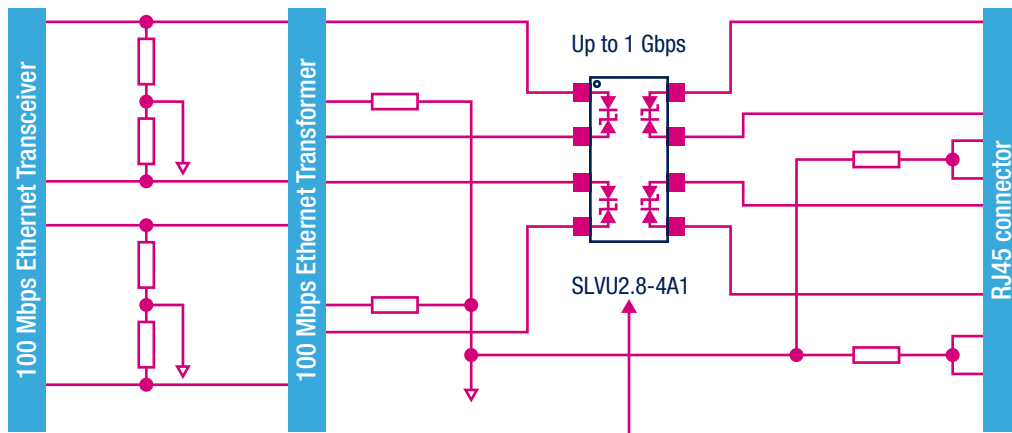

S0-8

**SLVU2.8 or DSL01**  
3 triple Trisil in one S08/  
Transil + Trisil in one package



## Proximity sensor protection

ST has developed specific and dedicated 200 W (10/1000  $\mu$ s) multi-line TVS for 2 and 3-wire proximity sensors. The SPT series provides reverse polarity and surge protection in compliance with IEC 61000-4-5, IEC 61131-2 and EN 60947-5-2.

### 3-wire sensor: SPT01-335DEE

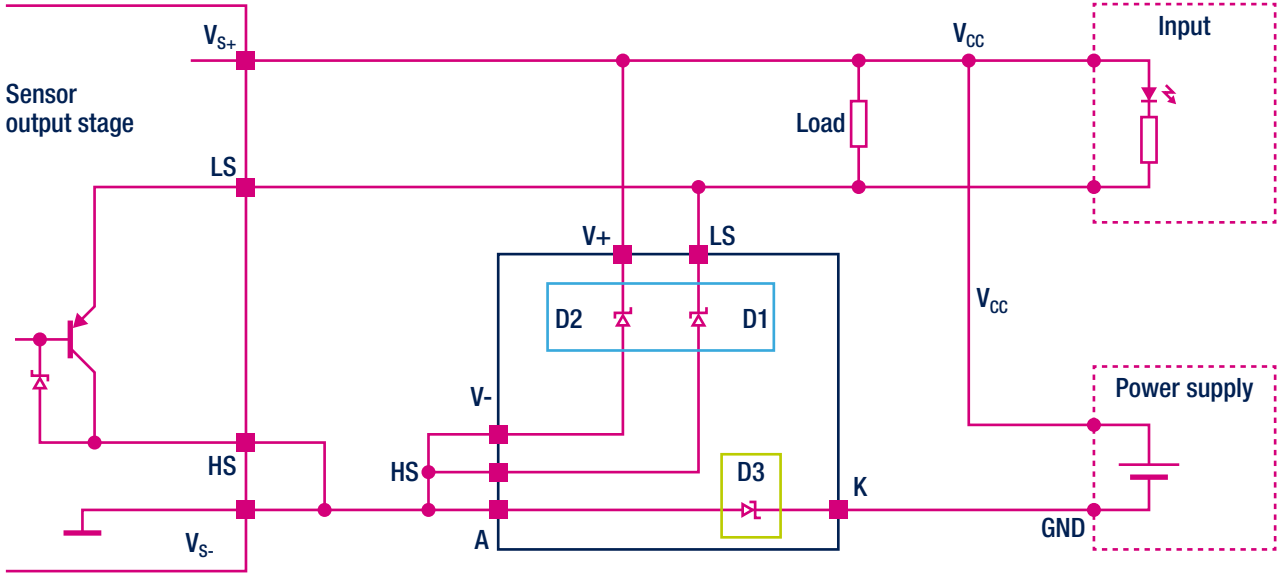

### 2-wire sensor: SPT02-236DDB

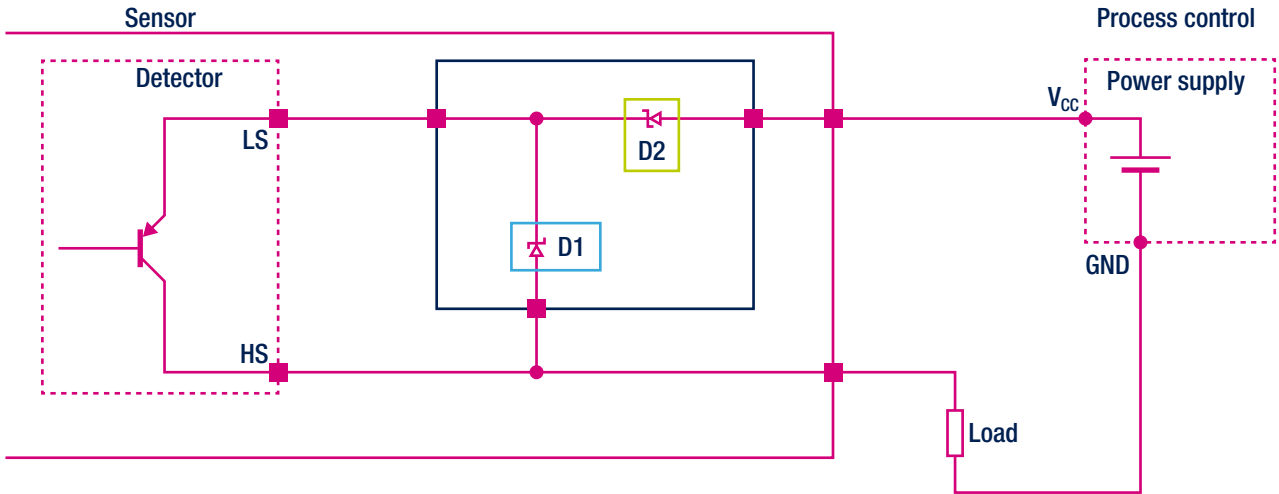

## 2 FEATURES:

- Surge protection
- Reverse battery protection

## FACTORY AUTOMATION NEEDS:

- 2-/3-line protection
- 36 V VRM required (even if  $V_{supply} = 24$  V typ)
- $V_{CL} @ IPP = 46$  V @ 2 A
- Diode specified in forward mode

## E-fuses

E-fuses are electronic fuses that can replace larger conventional fuses or other discrete protection devices, reducing ownership costs in production and in the field.

Unlike fuses, they offer programmable protection and flexible management of the fault, without requiring replacement after actuation. They thus help to improve equipment uptime and availability and also reduce maintenance costs and false returns.

Product family is composed by STEF033 (3.3 V line), STEF05 (5 V line), STEF4S (3.3 V and 5 V lines) and STEF12 (12 V line), all in 3 x 3 mm VDFPN 10 package. STEF033 is also offered in very tiny 1.2 x 1.2 mm CSP 9 bumps package.



# Field layer

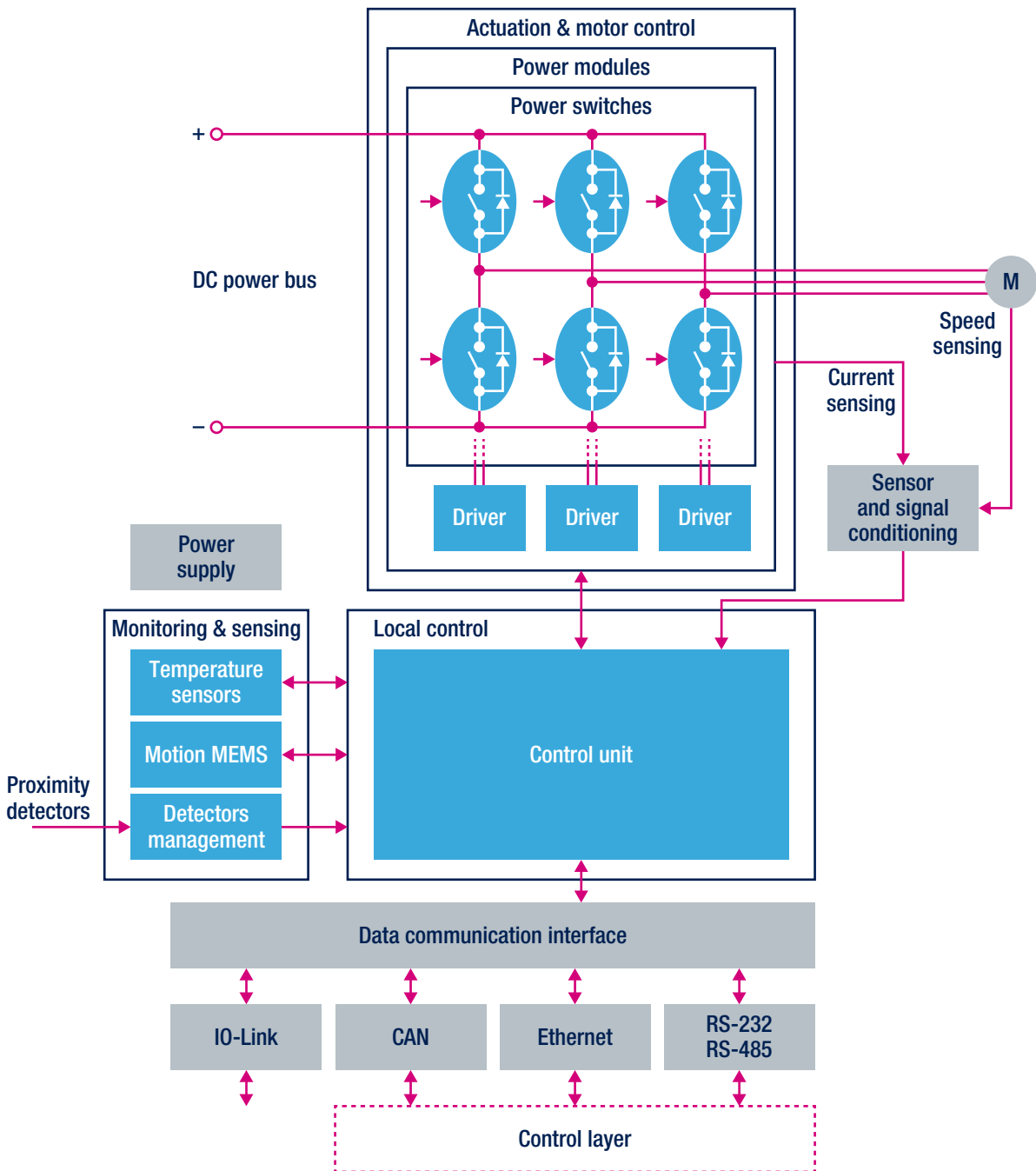

34

Despite its operational- and task-oriented nature, the field layer of any factory automation plant is more than a collection of tools and switches. Over the years, this level has been enriched, making the complexity of this level comparable to the control layer. One of the key criteria is the packages: usually at this level there is a strong interest in thermal management, due to the high power required in the field. Some of the device families are repeated for clarity but, in some cases where they are considered as redundant, they are treated briefly in order not to miss the connections between the various parts.

## FIELD BUS AND INDUSTRIAL ETHERNET HW IMPLEMENTATION

We look here at the devices and solutions to implement field buses. Architectures are based around MCUs and DSPs, and the following considerations are fundamental:

- Flexibility for the different protocols
- Real-time implementation
- Functional safety of the solution
- Power and space versus cost

These considerations result in the final implementation which can have different levels of scalability:

- MCU: lowest implementation cost
- MCU + FPGA: the use of an FPGA as glue logic enhances protocol flexibility and I/O extension
- MCU + ASIC or ASSP: a dedicated platform is often the result of consortium choices in building new standards
- System on chip: optimized solution resulting in best efficiency and performances

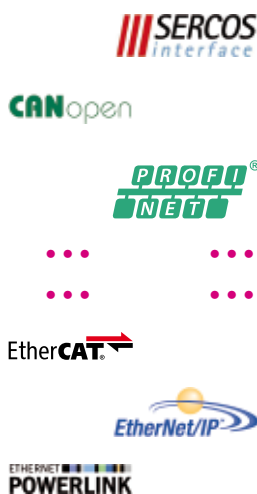

### MCU based architecture

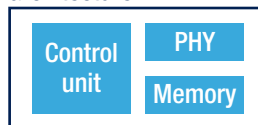

### MCU + ASIC (or ASSP) architecture

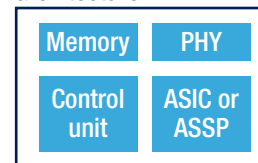

### MCU + FPGA architecture

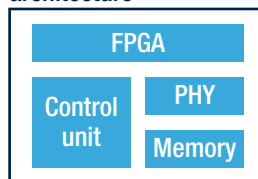

### SoC based architecture



### Industrial Ethernet HW Implementation

- Best technology trade-off
- Deterministic
- Dedicated Real-Time data
- HW and SW partitioning
- High reliability
- Functional Safety
- Open Standards
- Scalability
- Development Time + Cost
- Consortiums and Partners

The diagram above is an attempt to define a very complex scenario, focusing on the four main architectural concepts previously introduced. For designers involved in developing an industrial protocol stack, the question often concerns which MCU has the features that best fit the required protocol. To answer this question, we give here a complete list of the industrial solutions with application field, provider and solution name (the protocol to be implemented), firstly for the STM32 family and then for our STM8 MCUs.

Solution name	Provider	Application	Model	Cost	STM32 series and availability			
					F1	F2	F4	L1
CANopen	eCosCentric	Factory automation	Sources	License	Y	Y	Y	N
CANopen	IXXAT	Automation, Medical	Source	License	Y	Y	Y	N
CANopen	MicroControl	Factory automation	Binaries	License + royalties	Y	Y	Y	N
CANopen	Port	Factory automation	Source	License	Y	Y	Y	N
DALI	ST	Lighting	Source	Free	Y	Y	Y	Y
DeviceNet	IXXAT	Factory automation	Source	License	Y	Y	Y	N
DeviceNet	MicroControl	Factory automation	Binaries	License + royalties	Y	Y	Y	N
DeviceNet	Port	Factory automation	Source	License	Y	Y	Y	N
DLMS / COSEM	Andrea Informatique	Metering	Binaries	License	Y	Y	Y	Y
DMX	ST	Lighting/home & building automation	Source	Free	Y	N	N	N
eCosPro-CAN	eCosCentric	Factory automation	Sources	License	Y	Y	Y	N
EtherCAT	IXXAT	Factory automation	Source	License	Y	Y	Y	Y
EtherCAT	MicroControl	Factory automation	Binaries	License + royalties	N	Y	Y	N
EtherCAT <sup>3</sup>	Port	Factory automation	Source	License	Y	Y	Y	N
Ethernet/IP	IXXAT	Factory automation	Source	License	N <sup>1</sup>	Y	Y	N
Ethernet/IP <sup>3</sup>	Port	Factory automation	Source	License	Y	Y	Y	N
Ethernet/IP	TMG	Factory automation	Source	License + royalties	N	Y	Y	N
HART Master/Slave	MESCO	Process automation	Source	License + royalties	Y	Y	Y	N
IEEE 1588 PTP	IXXAT	Factory automation	Source	License	Y	Y	Y	N
IO-Link	TEConcept	Factory automation	Binaries	License + royalties	Y	N	N	N
IO-Link	TEConcept	Factory automation	Source	License	Y	Y	Y	Y

Solution name	Provider	Application	Model	Cost	STM32 series and availability			
					F1	F2	F4	L1
J1939	IXXAT	Commercial vehicles	Source	License	Y	Y	Y	N
Modbus	MESCO	Factory automation	Source	License + royalties	Y	N	N	N
Modbus RTU/ASCII	Embedded Solutions	Factory automation	Binaries	License + royalties	Y	Y	Y	N
Modbus RTU/ASCII	Port	Factory automation	Source	License	Y	Y	Y	N
Modbus TCP	IXXAT	Factory automation	Source	License	Y	Y	Y	N
Modbus TCP <sup>3</sup>	Port	Factory automation	Source	License	Y	Y	Y	N
µC/Modbus	Micrium	Factory automation	Source	License	Y	Y	Y	N
OPC-UA server	Embedded Labs	Factory and building automation	Binaries	License + royalties	N	Y	Y	N
openSAFETY	IXXAT	Factory automation	Open source	Free	Y	Y	Y	N
POWERLINK	IXXAT	Factory automation	Source	License	Y	Y	Y	N
POWERLINK <sup>3</sup>	Port	Factory automation	Source	License	Y	Y	Y	N
Profibus PA	MESCO	Factory automation	Binaries	License + royalties	Y	N	N	Y
Profibus DP and PA	TEConcept	Factory automation	Source	License	Y	Y	Y	Y
PROFINET	IXXAT	Factory automation	Source	License	N	N <sup>2</sup>	N <sup>2</sup>	N
PROFINET	Port	Factory automation	Source	License	N	Y	Y	N
PROFINET	TMG	Factory automation	Source	License + royalties	N	Y	Y	N
PTPd	PTPd	Factory automation	Open source (BSD) <sup>4</sup>	free	Y	N <sup>1</sup>	N <sup>1</sup>	N <sup>1</sup>
Sercos III	IXXAT	Factory automation	Source	License	Y	Y	Y	Y

Note: 1: Please contact provider

2: Possible with external memory usage

3: With external MAC or with ESC1100/1200 (EtherCAT)

4: PTPd ported on STM32 by ST

## INDUSTRIAL COMMUNICATION SOLUTIONS WITH STM8 MCUS

Solution name	Provider	Application	Model	Cost	STM8 series and availability		
					S	A	L
DALI	ST	Lighting	Source	Free	Y	N	Y
IO-Link	TEConcept	Factory automation	Binaries	License	Y	N	Y
IO-Link	TEConcept	Factory automation	Source	License	Y	Y	Y
KNX	TAPKO	Building automation	Binaries	License + royalties	N	N	Y

## IO-LINK

The L6360 and L6362A are the key products in the implementation of the IO-Link communication standard, inherent to the field layer.

The IO-Link communication standard is now ready for the factory automation market.

By definition, the communication is organized among a master and some slaves (called devices in the standard).

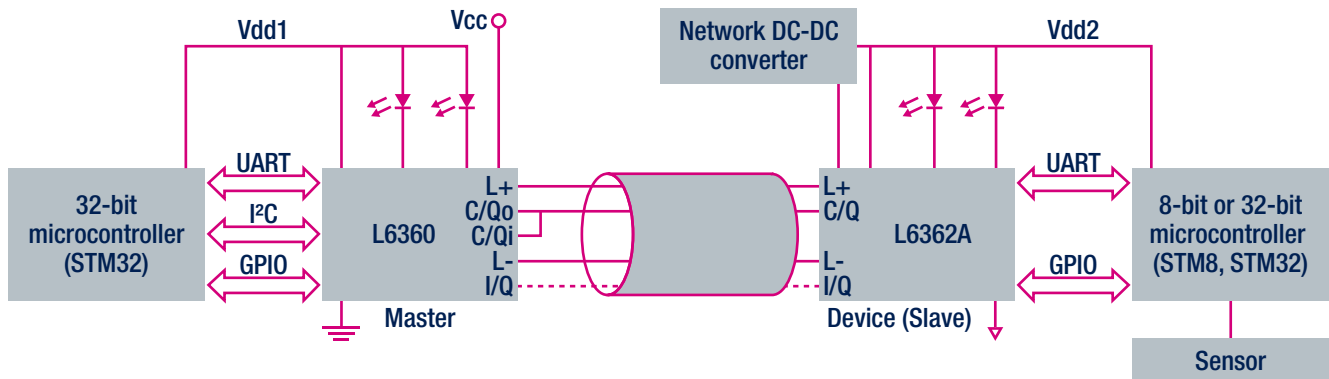

By using a state-of-the-art technology (MultiPower BCD) that allows the design of the logic part, and robust LV power MOSFETs in the same chip, ST offers an efficient, compact and cost-effective solution to drive any 3-wire digital sensor.

Modern sensors and actuators require:

- Remote service
- Standardization
- Sensor functionality verification
- Diagnostics
- Monitoring

The L6360 and L6362A (which is in advanced development status) I/O industrial transceiver ICs meet all these requirements. These new ICs offer the market IO-Link sensors/actuators that work without special cables. They feature an advanced solution that can be integrated even in old systems, that is neutral to any field bus, and keeps P2P communication.

Industrial transceiver ICs are designed to be compliant with burst tests, surge tests and ESD immunity tests, based on the IO-Link specification and SIO mode requirements.

## INDUSTRIAL TRANSCEIVER IC PRODUCT RANGE

Part number	Supply voltage (V)	V <sub>DD</sub> (V)	Output current (A)	I <sub>max</sub> linear reg. (mA)	Technology	Output channels	Input channels	Package
<b>L6360 (Master)</b>	18 to 32.5	3.3/5	0.5	65	MultiBCD	2	2	QFN 26L 3.5 x 5
<b>L6362A (Device)*</b>	5 to 40	3.3/5	0.2	8	MultiBCD	1	1	DFN 12L 3 x 3

Note: \* in development

## IO-LINK EVALUATION BOARDS

Order code	Description	Application notes
<b>STEVAl-IFP016V2</b>	IO-Link communication master transceiver demonstration board based on the L6360	AN4075



## LOCAL CONTROL



This section highlights the devices commonly used in this layer. Traditionally, this is the field of simple control tasks, where a minimum set of peripherals and no great computational capacity is required to the control stage. Our powerful 8-bit MCU family is ideal here, while the STM32 F0 and L1 series from ST's 32-bit STM32 family finds a place in cost-effective, field layer applications.

A few examples for the industrial environment from our portfolio of around 120 devices are provided below ([www.st.com/stm8s](http://www.st.com/stm8s)). The STM8L series, ST's 8-bit ultra-low-power MCU family, is proposed with devices embedding an LCD display controller (4 x 44/8 x 40) ([www.st.com/stm8l](http://www.st.com/stm8l)).

Part number	Flash size (Kbytes)	Internal RAM size (Kbytes)	Data EEPROM (bytes)	Package	Timer functions		ADC	DAC	I/Os	Serial interface				Supply voltage (V)	Supply current (I <sub>CC</sub> )		Maximum operating temperature range (°C)
					16-/32-bit timers	Others				CAN	SPI	I <sup>2</sup> C	UART (rDA, ISO 7816)		Lowest power mode (µA)	Run mode (per MHz) (µA)	
<b>STM8S003/005/007 Value line – 16 MHz CPU</b>																	
<b>STM8S003F3</b>	8	1	128	TSSOP20, UFQFPN20	1x8-bit, 2x16-bit	2 x WDG, beeper	5x10-bit		16		1	1	1	2.95 to 5.5	230	421	-40 to +85
<b>STM8S007C8</b>	64	6	128	LQFP48	1x8-bit, 3x16-bit		10x10-bit		38		1	1	2	2.95 to 5.5	500	421	
<b>STM8S103/105 Access line – 16 MHz CPU</b>																	
<b>STM8S103F2</b>	4	1	640	SO20, TSSOP20, UFQFPN20	1x8-bit, 2x16-bit	2 x WDG, beeper	5x10-bit		16		1	1	1	2.95 to 5.5	5	230	-40 to +125
<b>STM8S105C4</b>	16	2	1024	LQFP48	1x8-bit, 3x16-bit		10x10-bit		38		1	1	1	2.95 to 5.5	5	430	
<b>STM8S105S6</b>	32	2	1024	LQFP44	1x8-bit, 3x16-bit		9x10-bit		34		1	1	1	2.95 to 5.5	5	430	
<b>STM8S207C6</b>	32	6	1024	LQFP48	1x8-bit, 3x16-bit	2 x WDG, beeper	10x10-bit		38		1	1	2	2.95 to 5.5	5	500	
<b>STM8S208C6</b>	32	6	2048	LQFP48	1x8-bit, 3x16-bit		10x10-bit		38	1	1	1	2	2.95 to 5.5	5	500	
<b>STM8S207M8</b>	64	6	2048	LQFP80	1x8-bit, 3x16-bit		16x10-bit		68		1	1	2	2.95 to 5.5	5	500	
<b>STM8S208R8</b>	64	6	2048	LQFP64	1x8-bit, 3x16-bit		16x10-bit		52	1	1	1	2	2.95 to 5.5	5	500	
<b>STM8S208RB</b>	128	6	2048	LQFP64	1x8-bit, 3x16-bit		16x10-bit		52	1	1	1	2	2.95 to 5.5	5	500	
<b>STM8S903 Application specific line - 16 MHz CPU</b>																	
<b>STM8S903F3</b>	8	1	640	SO20, TSSOP20, UFQFPN20	1x8-bit, 2x16-bit	2 x WDG, beeper	5x10-bit		16		1	1	1	2.95 to 5.5	5	230	-40 to +125
<b>STM8L series – ultra-low-power MCUs - 16 MHz CPU</b>																	
<b>STM8L151C2</b>	4	1	256	LQFP48	1x8-bit, 2x16-bit	2 x WDG, AWU, RTC, beeper	28x12-bit		41		1	1	1	1.65 to 3.6	0.35	180	-40 to +125
<b>STM8L152M8*</b>	64	4	2048	LQFP80	1x8-bit, 4x16-bit		28x12-bit	2x12-bit	68		2	1	3	1.65 to 3.6	0.4	200	
<b>STM8L162M8</b>	64	4	2048	LQFP80	1x8-bit, 4x16-bit		28x12-bit	2x12-bit	68		2	1	3	1.65 to 3.6	0.4	200	
<b>STM8L162R8</b>	64	4	2048	LQFP64	1x8-bit, 4x16-bit		28x12-bit	2x12-bit	54		2	1	3	1.65 to 3.6	0.4	200	







Note: \* this device is provided with a 4 x 44/8 x 40 display controller (LCD)

A wide choice of free C compilers and IDEs is available for STM8 MCUs ([www.st.com/stm8tools](http://www.st.com/stm8tools)).

Free tools suites, software libraries and examples			
Development environment	 life.augmented		
C-Compilers	NA	Free up to 32-Kbyte One year renewable	Free up to 8-Kbyte On month full size
IDE	STVD	IDEA	EWSTM8

A wide offer of hardware solutions and starter kits is also available for our 8-bit MCU families: the STM8 S, STM8 A (the automotive line), as well as the STM8 L.

The full list of evaluation boards is available at [www.st.com/stm8tools](http://www.st.com/stm8tools).

Part number	Description	Image
ST-LINK/V2	The ST-LINK/V2 is an in-circuit debugger and programmer for the STM8 and STM32 MCU families. The single wire interface module (SWIM) and JTAG/serial wire debugging (SWD) interfaces are used to communicate with any STM8 or STM32 microcontroller located on an application board.	
ST-LINK/V2-ISOL	In-circuit debugger/programmer with digital isolation	
STX-RLINK	The RLink (STX-RLINK) is Raisonance's versatile, low-cost, in-circuit debugger and programmer for the complete range of ST's MCUs (STM8, ST7, STM32, STR7 and STR9). It connects to application or evaluation boards for in-circuit programming and debugging via an industry standard JTAG-SWD connection for ARM® core-based microcontrollers, via ST's SWIM connection for STM8, or via an in-circuit communication (ICC) connection for ST7 microcontrollers. ST72C devices are not supported.	
STEVAL-IFN004V1	The STEVAL-IFN004V1 demonstration board is based on ST's STM8S105 MCU and the DMOS fully integrated 3-phase motor driver L6230 implementing 6-step scalar control of BLDC motors.	
STEVAL-IAS003V1	The STEVAL-IAS003V1 counter demonstration board is intended as an example for applications where a directly-driven LCD with the associated programmable functionality is needed.	
STEVAL-ICB003V1	The STEVAL-ICB003V1 demonstration board is a general-purpose front panel solution, using a TLED316S LED driver, STMPE1208S capacitive touch sensor and an 8 bit STM8S207K6 MCU.	



Application notes, free software examples, dedicated application libraries including motor control, are also available for free download ([www.st.com/stm8](http://www.st.com/stm8)). To complete the picture, some examples of the entry-level, 32-bit STM32 F0 MCUs ([www.st.com/stm32f0](http://www.st.com/stm32f0)) as well as STM32 L1 series ([www.st.com/stm32l1](http://www.st.com/stm32l1)), are provided in the table below.

Part number	Flash size (Kbytes)	Internal RAM size (Kbytes)	Package	Timer functions		ADC	DAC	I/Os	Serial interface					Supply voltage (V)	Supply current (I <sub>CC</sub> )		Maximum operating temperature range (°C)
				16-/32-bit timers	Others				SPI	I <sup>2</sup> S	I <sup>2</sup> C	USART	CEC		Lowest power mode (µA)	Run mode (per MHz) (µA)	
<b>STM32 L1 series ARM® Cortex™-M3-based – ultra-low-power 32 MHz CPU<sup>1</sup></b>																	
STM32L100C6	32	4	UFQFPN48	6x16-bit	SysTick, 2 x WDG, RTC	16x12-bit	2x12-bit	37	2		2	3		1.8 to 3.6	0.3	230	-40 to 85
STM32L151C8	64	10	LQFP48, UFQFPN48	6x16-bit		12x12-bit	2x12-bit	36	2		2	3		1.65 to 3.6	0.3	230	
STM32L152QD	384	48	UFBGA132	8x16-bit/1x32-bit		39x12-bit	2x12-bit	108	3	2	2	5		1.65 to 3.6	0.3	230	
STM32L162RD <sup>2</sup>	384	48	LQFP64			21x12-bit	2x12-bit	50	3	2	2	5		1.65 to 3.6	0.3	230	
<b>STM32 F0 series ARM® Cortex™-M0-based – STM32F051 line with 48 MHz CPU and DAC</b>																	
STM32F030R8	64	8	LQFP64	6x16-bit	SysTick, 2x WDG, RTC, 24-bit downcounter	1x12-bit		55	2		2	2		2.4 to 3.6	3.4	250	-40 to 85
STM32F031C4	16	4	LQFP48	5x16-bit/1x32-bit		13x12-bit		39	1	1	1	1		2.0 to 3.6	1.7	250	
STM32F051R4	16	4	LQFP64	7x16-bit/1x32-bit		19x12-bit	1x12-bit	55	1	1	1	1		2.0 to 3.6	1.65	250	
STM32F051R8	64	8	LQFP64	7x16-bit/1x32-bit		19x12-bit	1x12-bit	55	2	1	2	2	1	2.0 to 3.6	1.7	250	
STM32F051K8	64	8	UFQFPN32	7x16-bit/ 1x32-bit		13x12-bit	1x12-bit	27	1	1	1	2	1	2.0 to 3.6	1.65	250	
STM32F071VB	128	16	LQFP100	9x16-bit/1x32-bit		19x12-bit	1x12-bit	87	2	1	2	4	1	2.0 to 3.6	1.8	260	
STM32F072RB <sup>3</sup>	128	16	LQFP64	8x16-bit/1x32-bit		19x12-bit	2x12-bit	51	2	2	2	4	1	2.0 to 3.6	1.8	260	
STM32F072VB <sup>3</sup>	128	16	LQFP100	8x16-bit/1x32-bit		19x12-bit	2x12-bit	87	2	2	2	4	1	2.0 to 3.6	1.8	260	

Notes: 1: Packages reported in this column are only one example of the packages' availability of the corresponding device.  
 2: STM32L162 line includes LCD and AES. The STM32L162RD embeds 16384Kbytes data, 1x USB FS, 1x SDIO, 1x FSMC and a 4x32 / 8x28 LCD controller.  
 3: STM32F072RB and STM32F072VB includes CAN interface and USB 2.0 full-speed interface.

STM32 F0 MCUs are supported with evaluation tools to shorten design time ([www.st.com/stm32f0discovery](http://www.st.com/stm32f0discovery)).

The STM32 F0 Discovery kit, 32F0308DISCOVERY, features

- STM32F051R8T6 microcontroller with 64-Kbyte Flash, 8-Kbyte RAM in an LQFP64 package
- On-board ST-LINK/V2 with selection mode switch to use the kit as a standalone STLINK/V2 (with SWD connector for programming and debugging)
- Board power supply: through USB bus or from an external 5 V supply
- External application power supply: 3 V and 5 V
- Four LEDs:
  - LD1 (red) for 3.3 V power on
  - LD2 (red/green) for USB communication
  - LD3 (green) for PC9 output
  - LD4 (blue) for PC8 output
- Two pushbuttons (user and reset)
- Extension header for all LQFP64 I/Os for quick connection to prototyping board and easy probing
- An additional board is provided that can be connected to the extension connector for even easier prototyping and probing



## MONITORING AND SENSING

### MEMS motion sensors

ST's MEMS (micro electromechanical sensors) portfolio includes accelerometers, gyroscopes, digital compasses and inertial modules ([www.st.com/mems](http://www.st.com/mems)). ST is a worldwide leader for these devices thanks to:

- A unique sensor portfolio, from discrete to fully-integrated solutions, to meet every design need
- High-volume manufacturing capacity to provide cost-competitive solutions, fast time-to-market and security of supply
- High performance sensor fusion to improve the accuracy of multi-axis sensor systems to enable new emerging and highly-demanding applications, such as indoor navigation and location based services
- High-level quality products, already tested in different application fields, including mobile, portable, gaming, consumer, automotive, healthcare and industrial segments (more than 3 billion pieces shipped worldwide)
- Multiple dedicated sites for MEMS foundry, assembly and testing lines, with complete in-house dual sourcing

MEMS motion sensors (accelerometers, gyroscopes, digital compasses and inertial modules) are finding uses in advanced industrial applications, including:

- Robotics and automation (accelerometers, gyroscopes)
  - Inertial navigation, to increase the accuracy of wheel encoders, self-balance robots
  - Condition monitoring of industrial equipment and transportation (high g accelerometers)
- Asset and parcel tracking and monitoring (high g accelerometers, gyroscopes)
  - Impact detection and logging
- Building and structure monitoring (accelerometers)
  - Vibration and tilt monitoring
- Seismic exploration and geophones/ idrophones (accelerometers)
  - Vibration monitoring
- Drill (accelerometers, gyroscopes)
  - Safety, detecting excessive rotation on the body of the drill if chuck gets stuck
  - Tilt detection

Part number	Full scale	Noise density (Typ.)	Package size (mm)	Key features
<b>Accelerometers</b>				
LIS2DH	±2, ±4, ±8, ±16 g	220 µg/√Hz	2 x 2 x 1 LGA-14	12-bit, embedded FIFO
LIS3DSH	±2, ±4, ±8, ±16 g	150 µg/√Hz	3 x 3 x 1 LGA-16	16-bit, state machine, embedded FIFO
LIS331HH	±6, ±12, ±24 g	650 µg/√Hz	3 x 3 x 1 LGA-16	16-bit, up to ±24g full scale
H3LIS331DL	±100, ±200, ±400 g	15000 µg/√Hz	3 x 3 x 1 TFLGA-16L	16-bit, up to ±400g full scale, low power, high shock survivability
LIS344ALH	±2, ±6 g	50 µg/√Hz	4 x 4 x 1.5 LGA-16L	Analog output
AIS328DQ	±2, ±4, ±8 g	218 µg/√Hz	4 x 4 x 1.8 QFN 24	AEC-Q100 qualification*, 16-bit, temp. range: -40 to 105 °C
<b>Gyroscopes</b>				
L3GD20	±250, ±500, ±2000 dps	0.03 °/s/√Hz	4 x 4 x 1 LGA-16	Immunity to audio noise, embedded FIFO
A3G4250D	±245 dps	0.03 °/s/√Hz	4 x 4 x 1 LGA-16	AEC-Q100 qualification(*)
<b>Magnetometer</b>				
LIS3MDL	±4/ ±8/ ±12/ ±16 gauss	X, Y axes: 3.2* mgauss Z axis: 4.1* mgauss	2 x 2 x 1 LGA-12	16-bit data output, interrupt generator, self-test
<b>Inertial modules</b>				
LSM330DLC	±2, ±4, ±8, ±16 g ±250, ±500, ±2000 dps	220 µg/√Hz 0.03 °/s/√Hz	4 x 5 x 1.1 LGA-28L	6-axis system in package (SiP) with embedded FIFO, temperature sensor and programmable interrupt generators
LSM330D	±2, ±4, ±8, ±16 g ±250, ±500, ±2000 dps	220 µg/√Hz 0.03 °/s/√Hz	3 x 5.5 x 1 LGA-28L	6-axis system in package (SiP) with embedded FIFO, temperature sensor and programmable interrupt generators
INEMO-M1	±2, ±4, ±8, ±16 g ±250, ±500, ±2000 dps ±1.3 to ±8.1 Gauss	220 µg/√Hz 0.03 °/s/√Hz 2 mgauss (resolution)	13 x 13 x 2 PCB	9-axis system on board (SoB) with all the features and power of the STM32F103 32-bit MCU in a solderable module, Temp. range: -40 to +85 °C
<b>Digital compasses</b>				
LSM303D	±2, ±4, ±8, ±16 g ±2, ±4, ±8, ±12 gauss	150 µg/√Hz 5 mgauss	3 x 3 x 1 LGA-16L	Embedded FIFO and temperature sensor Programmable interrupt generators

Note: \* Automotive qualification is suitable in some specific industrial applications due to its inherent extended features' range

### INEMO® software engine features multi-sensor motion data fusion

The iNEMO engine sensor fusion suite is a filtering and predictive software. It uses advanced algorithms to integrate outputs from multiple MEMS sensors in a smart way, independently of environmental conditions, to reach the best performances. Real-time motion-sensor data fusion is set to significantly improve the user experience, increasing accuracy, resolution, stability and response time in advanced motion-based applications in consumer, computer, industrial and medical fields.

The iNEMO engine can be combined with ST's iNEMO inertial modules to create the industry's first complete and customizable hardware/software multi-axis MEMS sensor solutions for enhanced motion and accurate heading recognition. Equipment manufacturers across different market segments can now easily and quickly deploy robust and reliable high-performance motion detection systems with up to 10 degrees of freedom, comprising 3-axis sensing of linear, angular, and magnetic motion with barometer/altitude readings from a pressure sensor, enabling true augmented-reality applications ([www.st.com/inemo-engine](http://www.st.com/inemo-engine)).

#### BENEFITS

- Absolute point tracking and motion tracking accuracy
- Immunity to magnetic interference for high performance in real-world conditions
- Few user-calibration interruptions, enabling innovative and longer game play
- Reliable compass heading for accurate navigation
- Accurate direction, enabling true augmented-reality applications



## iNEMO® SOFTWARE

Software version	Description	Sensor fusion library code
<b>INEMO-ENG-M1LI3</b>	Lite version for INEMO-M1: Based on the Kalman filter theory applied to MEMS sensors, iNEMO M1 lite software library is a free source code that can be used for the STM32 and for customizable HW/SW solutions.	Source code
<b>iNEMOEngine_PW8</b>	Pro version: This firmware running on the STM32 manages sensors on Windows 8 using standard human interface devices (HID) over USB/I <sup>2</sup> C. Allows sensor plug-and-play recognition and new application development using Windows 8 standard APIs. (Compatible with Intel x86 and ARM processors)	Compiled code
<b>iNEMOEngine_PI3P Platform independent</b>	Pro version: This firmware allows you to develop new custom applications running on the STM32 or to collect real-time sensor fusion data thorough Virtual COM from any platform (platform independent).	Compiled code
<b>iNEMOEngine_PAAP</b>	Pro version: This is a complete solution to support Android platforms by providing the hardware abstraction layer, sensor drivers and sensor fusion library.	Compiled code

### MEMS sensor evaluation kit

ST has deep expertise in sensor integration and development of new applications and can assist customers in design-in. ST's evaluation kits and firmware provide a real-time evaluation of sensor performance in your applications ([www.st.com/mems-boards](http://www.st.com/mems-boards) and [www.st.com/mems-drivers](http://www.st.com/mems-drivers)).

#### EVALUATION KIT

ST offers a complete evaluation kit including:

- A motherboard compatible with all ST MEMS adapters, based on a high-performance 32-bit microcontroller (order code: STEVAL-MKI109V2)
- A full set of MEMS sensor adapters, that are complementary to the motherboard and can mount all sensors
- An innovative graphic user interface for direct and real-time access to the sensor configuration registers.

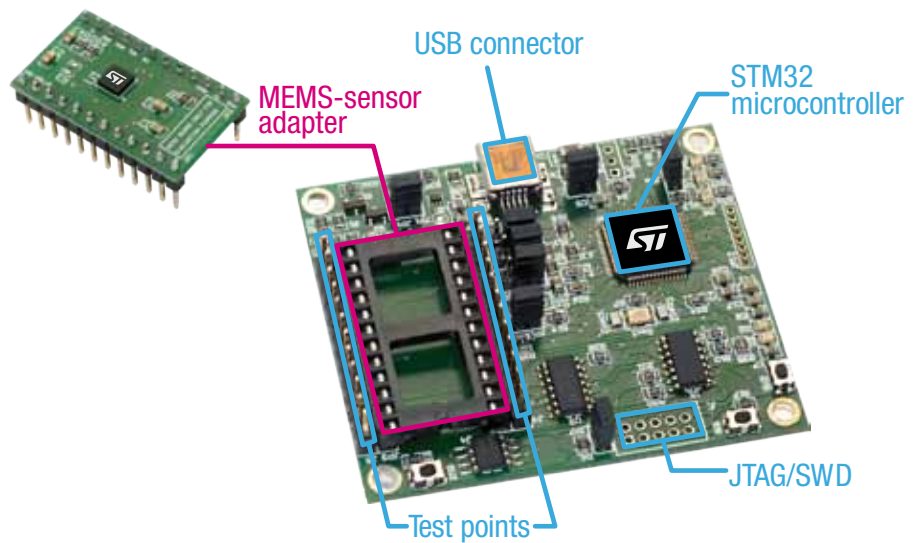

Part number	Description	Board type
<b>STEVAL-MKI119V1</b>	Motherboard + adapter board: STEVAL-MKI119V1 kit includes STEVAL-MKI109V2 (motherboard) + STEVAL-MKI108V2 (9-axis module, L3GD20 and LSM303DLHC)	Development kit
<b>STEVAL-MKI109V2</b>	MEMS motherboard based on STM32F103 high-performance ARM 32-bit Cortex™-M3 MCU Interfaces: USB connector, JTAG/SWD for debug Ready to support iNEMO Engine DFU compatible for USB microprocessor firmware update, compatible with all of ST's MEMS adapters	Motherboard
<b>STEVAL-MKI108V2 (9-axis)</b>	For all standalone sensors and modules, an adapter board designed to be plugged into the motherboard Board pinout compatible with a standard DIL24 socket Completed list is available on ST's web site.	Example of daughter board
<b>STEVAL-MKI115V1</b>	System ready for any wireless extension External Bluetooth dongle available	Extender board
<b>STEVAL-MKI121V1</b>	Evaluation board for INEMO-M1 that includes a pressure sensor LPS331AP representing a complete 10-DoF open platform; USB and SWD connectors for debugging and programming	Discovery-M1

## Temperature sensors

ST's temperature sensors include both analog and digital temperature sensor ICs. Both types are suitable for use in a wide range of applications, including the industrial segment ([www.st.com/tempsensors](http://www.st.com/tempsensors)).

Part number	Full scale	Type	Resolution	Key features	Package size (mm)
<b>STLM20</b>	-55 to +130 °C	Analog	Accuracy: 1.5 °C max at 25 °C ( $\pm 0.5$ °C typ)	Ultra-low current 2.4 V precision analog temperature sensor	1 x 1.3 x 0.5 UDFN-4L 2 x 2.1 SOT323-5L
<b>STTS751</b>	-40 to +125 °C	Digital	Accuracy: $\pm 1.0$ °C (typ) from 0 to +85 °C, $\pm 2.0$ °C (typ) from -40 to +125 °C	2.25 V low-voltage local digital temperature sensor	2 x 2 x 0.5 UDFN-6L 2.9 x 2.8 SOT23-6L

## Proximity detectors

Proximity sensors fall into three main categories: capacitive sensors, inductive sensors, and ultrasonic sensors.

IO-Link technology is the first standardized IO technology worldwide (IEC 61131-9) for communication with these sensors, as well as actuators. This powerful point-to-point communication is based on the long established 3-wire sensor and actuator connection, without additional requirements regarding the cable material. ST has developed physical layer interfaces according to the IO-Link system specification supporting this technology.

With our MCU families STM8 and STM32 plus IO-link stack, ST offers an unique product spectrum for this future technology.

The simplified block diagram below presents a complete system compliant with the IEC 60947-5-2 design recommendation. ST offers, for the front end block, BCD smart-power technology, able to match most ASIC specifications.

Inductive proximity detectors block diagram

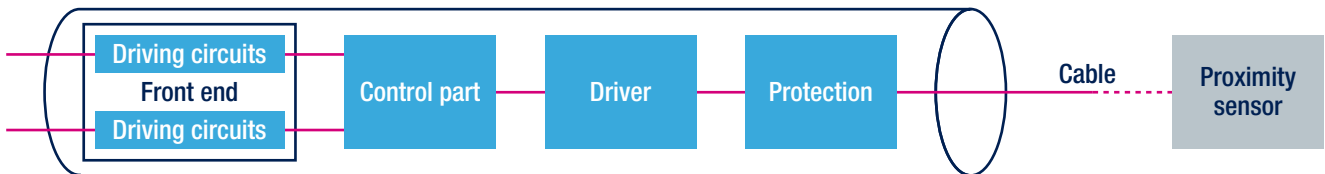

Part number	Function	Description	Package
<b>STM8L</b>	Control unit	8-bit MCU	LQFP, TFBGA, TSSOP 20, UFQFPN, WLCSP
<b>STM32F0</b>		32-bit MCU	LQFP, TSSOP 20, UFQFPN
<b>TDE1707</b>	Driver	Intelligent power switches	S08
<b>TDE1708DFT</b>			DFN 4x4mm
<b>L6362A</b>	Transceiver	IO-Link device	DFN 12L 3x3mm
<b>SPT01-335DEE</b>	Protection	Triple diode array for power bus protection	QFN3x3-6L 3x3x1 mm
<b>SPT02-236DDB</b>		Double diode array for switch protection and reverse blocking	$\mu$ QFN-2L 3.3x1.5x0.8 mm

The STEVAL-IFS006V2 demonstration board is an inductive proximity switch application based on metal body detection using the eddy current effect on the HF losses of a coil.

This evaluation board represents a very simple, compact and cost-effective solution for an inductive proximity switch with wide temperature range, supply voltage variation and noise immunity in industrial environments.



# ACTUATORS AND MOTOR CONTROL

ST has a wide portfolio and long experience in motor control. Smooth operation and high efficiency are the key factors driving development in this market. In particular, the growing demand for higher efficiency is these days supported by developments in advanced motor control algorithms such as field oriented control (FOC) for PMSM, BLDC and induction motors. This requires high-performance MCUs coupled either with motor drivers (such as intelligent power modules or monolithic ICs) or power transistors and gate drivers. For positioning or very low-speed applications, new highly-integrated controller/driver ICs for stepper motors run them more smoothly and with higher positioning precision.

Key enabling products are:

- Power MOSFETs and IGBTs
- Diodes
- SCR, Triacs and AC switches
- Gate drivers
- 8 and 32-bit microcontrollers
- Power modules
- Motor drivers ICs

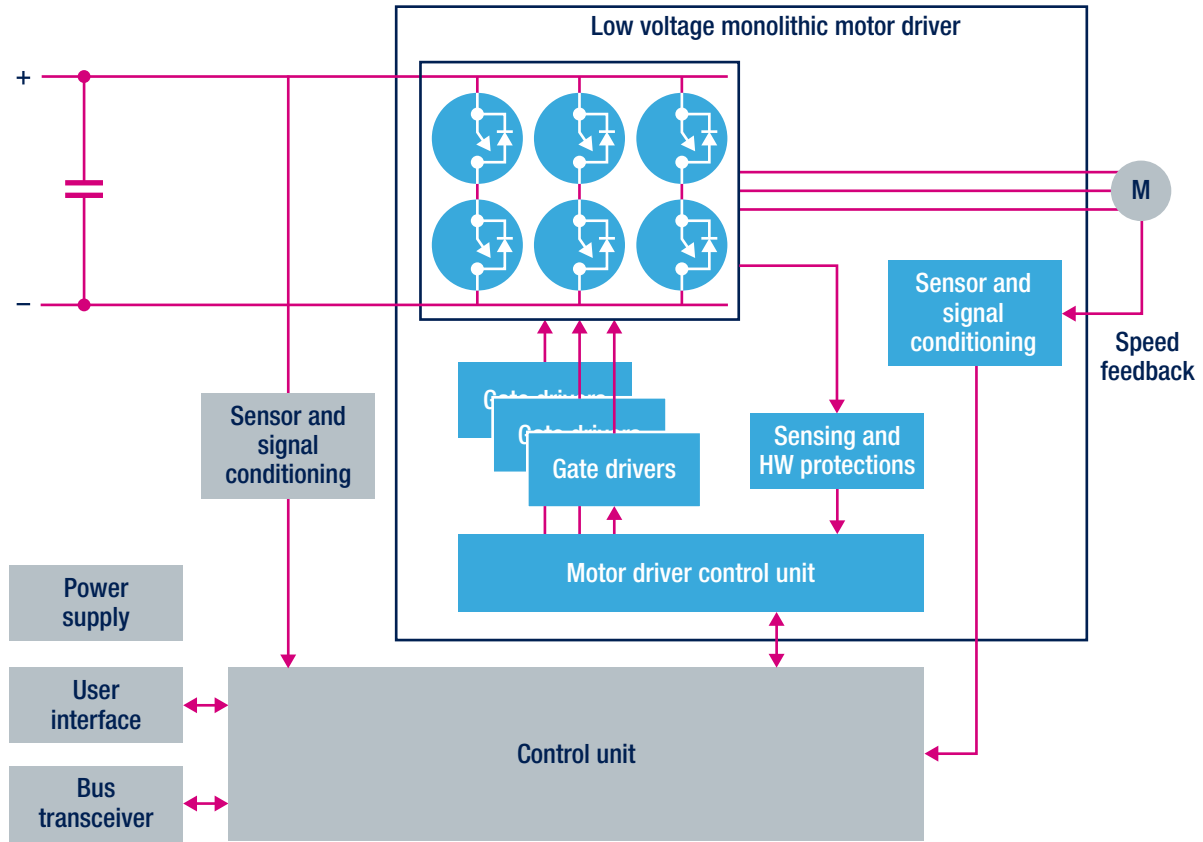

Actuation and motor control mean also microstepping. Factory automation is dominated by thousands of tools driven by DC stepper motors, differing primarily in the sequence needed to drive the motor and the respective circuit topology. Stepper motors can be driven in full step, half step and microstepping modes.

ST has provided drive ICs for all circumstances over many years. These drives have an associated demonstration board with our xSPIN families.

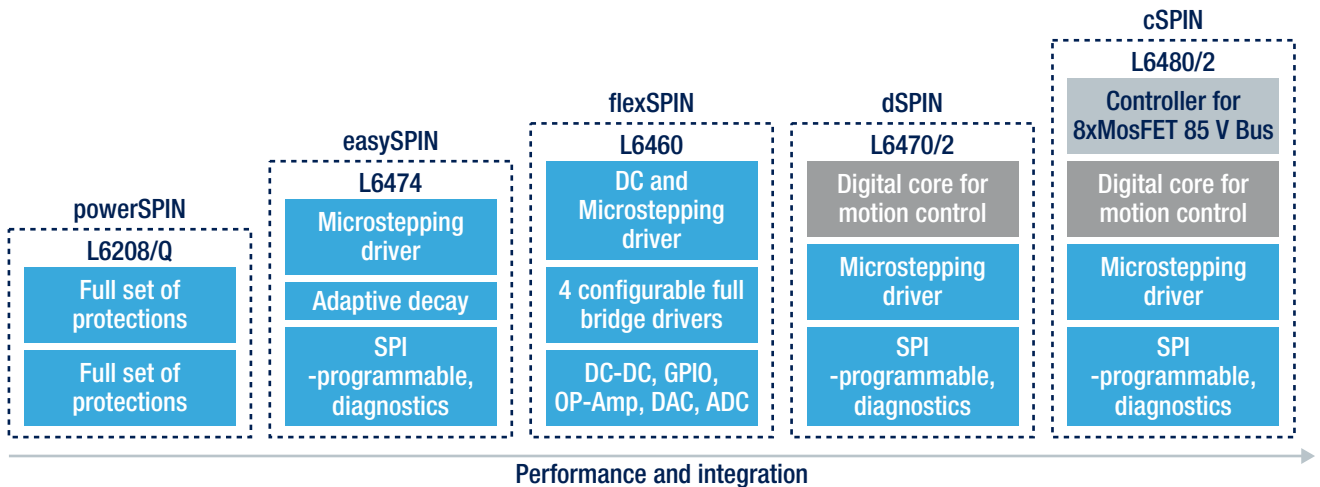



Motor control is too broad an application segment to be treated fully here. A full and self-contained documentation is available at [www.st.com/powerspin](http://www.st.com/powerspin).

ST also provides evaluation tools for motor control, based on the STM32 MCU family.

The STM32100B-MCKIT supports field oriented control (FOC) of 3-phase permanent magnet synchronous motors (PMSM). Single-shunt resistor current measurement is supported out-of-the-box allowing closed-loop torque control. Position measurement can be implemented using quadrature encoder sensors, Hall effect sensors or sensorless algorithms.

The STM32100B-MCKIT starter kit can be run either as a plug-and play, out-of-the-box demo with the provided PMSM motor, in sensorless torque or speed control mode; or in conjunction with a third-party IDE and C compiler, as a development kit for creating your own motor control application based on the STM32F100.

The STM3210B-MCKIT motor control starter kit comes ready-to-run with a PMSM motor or an AC induction motor (accessory). You can modify the demonstration application and develop your own motor control applications using the dedicated software libraries provided in the starter kit in conjunction with a third-party IDE and C compiler.

Also available are the ST MC Workbench (STSW-STM32003) PC GUI configuration tool for the STM32 PMSM FOC SDK motor control library (STSW-STM32100).

The Segger J-Link is included in the kit so you can connect to a host PC via an industry standard 20-pin JTAG connection. When connected to a host PC, the opto-isolation board provides galvanic isolation for the host PC and development tools on the 20-pin industry-standard JTAG connection.



### Power transistors

Leading-edge power technologies for low (<150 V), high (600/650 V) and very high voltage (1200 V and over) applications combined with a full package range and innovative die bonding technologies exemplify ST's innovation in power transistors.

Our portfolio includes MOSFETs ranging from -500 to 1500 V, silicon carbide (SiC) MOSFETs featuring the industry's highest temperature rating of 200 °C, IGBTs with breakdown voltages ranging from 350 to 1300 V and a wide range of power bipolar transistors.

For power applications up to 650 V, key ST technologies are the MDmesh II and V (low gate charge and the lowest  $R_{DS(on)}$  in the market) for the MOSFETs and the V-series for IGBTs, while the future is our GaN HEMT\* (high electron mobility transistor) technology, approaching an ideal switch.

Very high voltage applications are traditionally the domain of IGBTs and now also of SiC MOSFETs. Newly developed technologies for IGBTs are the STD series (PowerMESH technology) and the new H-series technology (175 °C rated, trench-gate field-stop, for high frequency applications). SiC MOSFETs are addressed by a new technology with temperature ratings up to 200 °C.

High voltage  
High current

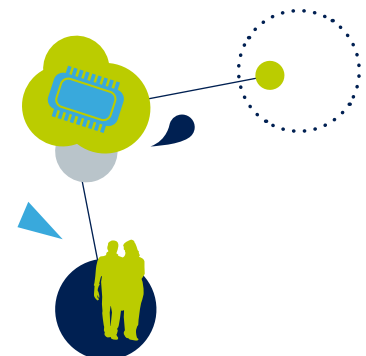
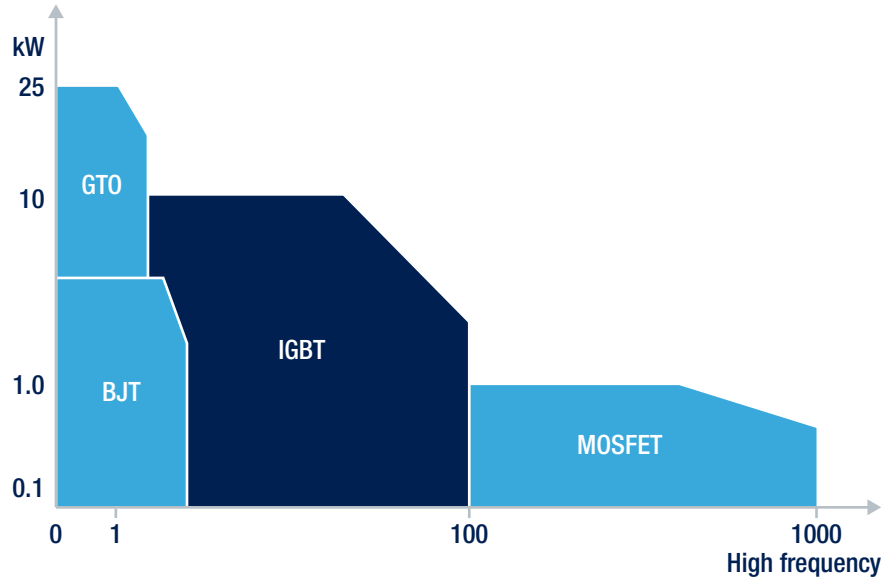

Note: \* in development



## Power MOSFETs

ST's offering of power MOSFETs includes hundreds of devices. The table below presents a selection with different packages and our latest silicon technologies, with voltages up to 650 V (and over). The following diagram indicates part number assignment.

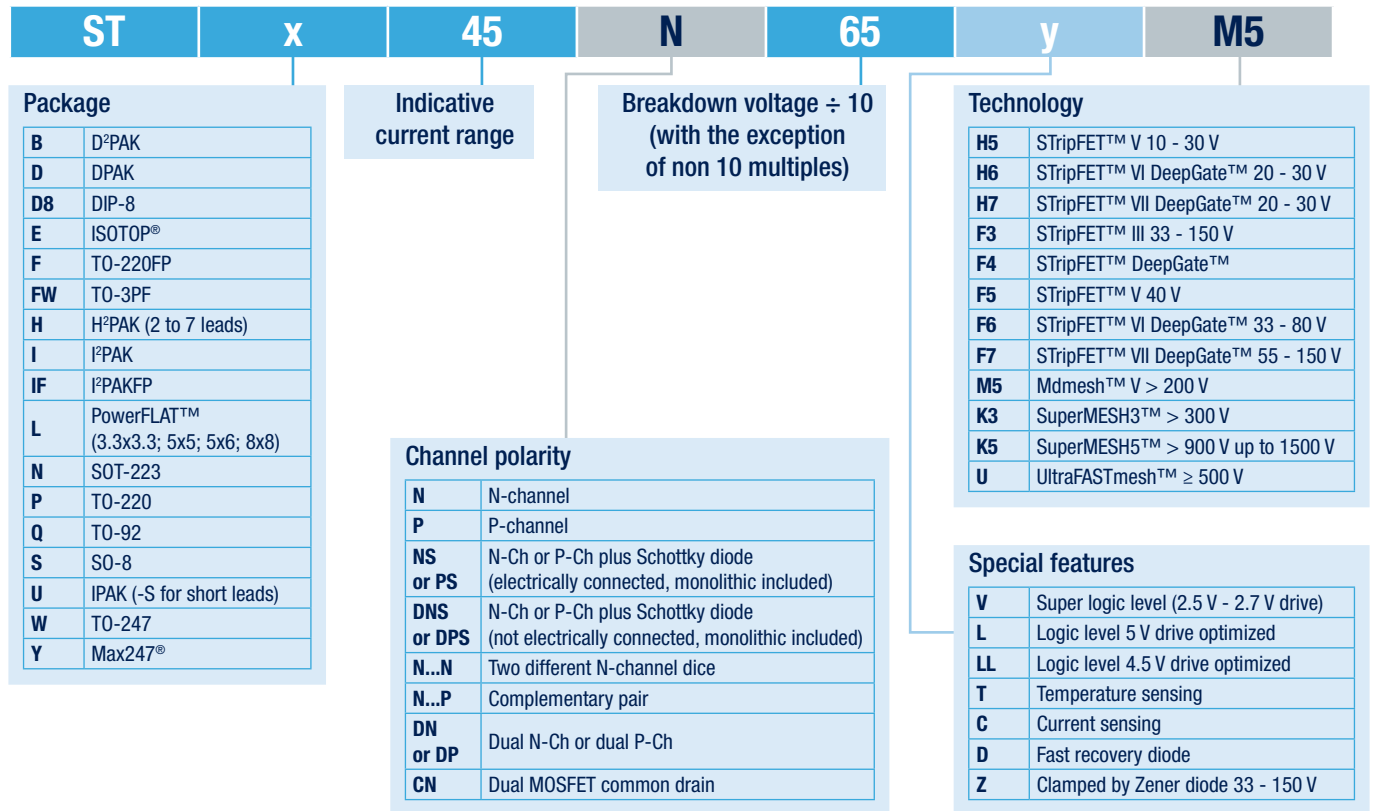

Part number	Package	V <sub>DSS</sub> (V)	R <sub>DS(on)</sub> (@ V <sub>GS</sub> = 10 V) max (Ω)	Drain current (Dc) (I <sub>D</sub> ) max (A)	Total power dissipation (PD) max (W)	Total gate charge (Q <sub>g</sub> ) typ (nC)
STL160N3LLH6	PowerFLAT 5x6	30	.0013	45	4.8	120
STH160N4LF6/2	H2PAK-2	40	.0032	120	150	180
STH320N4F6-2	H2PAK-2	40	.0013	200	300	160
STP270N8F7	TO-220	80	.0025	180	315	193
STS5N15F4	SO-8	150	.063	5	2.5	48
STL52N25M5	PowerFLAT 5x6	250	.076	4.2	2.5	47
STD6N52K3	DPAK	400	1.2	4.4	70	17
STW36N55M5	TO-247	550	.08	33	190	72
STY100NM60N	Max247	600	.029	98	625	330
STI34N65M5	I2PAK	650	.110	29	190	70
STW20N95K5	TO-247	950	.33	17.5	250	40
STW6N120K3	TO-247	1200	2.4	6	150	34
STFW4N150	TO-3PF	1500	7	4	63	30
STW3N170*	TO-247	1700	12	2.3	160	28

Note: \* preview

A wide choice of p-channel power MOSFETs, in a voltage range from -500 to -20 V, is also available ([www.st.com/powermosfets](http://www.st.com/powermosfets)).

Part number	Package	V <sub>DSS</sub> (V)	R <sub>DS(on)</sub> (@ V <sub>GS</sub> = 10 V) max (Ω)	Drain current (Dc) (I <sub>D</sub> ) max (A)	Total power dissipation (PD) max (W)	Total gate charge (Q <sub>g</sub> ) typ (nC)
STU10P6F6	IPAK	-60	.16	-10	35	6.4
STS10P3LLH6	SO-8	-30	.014	-10	2.5	50
STT3P2UH7	SOT23-6L	-20	-	-3	1.6	5.5

## SiC MOSFETs

Based on the advanced and innovative properties of wide bandgap materials, ST's silicon carbide (SiC) MOSFETs feature very low  $R_{DS(on)}$  \* area for the 1200 V rating combined with excellent switching performances, translating into more efficient and compact systems. Compared with silicon MOSFETs, SiC MOSFETs exhibit low on-state resistance \* area even at high temperatures and excellent switching performances versus the best-in-class 1200 V IGBTs in all temperature ranges, simplifying the thermal design of power electronic systems.

The main features and benefits of our SiC MOSFETs include:

- Very high temperature handling capability ( $T_{jmax} = 200\text{ °C}$ ) leading to reduced PCB form factors (simplified thermal management) as well as improved system reliability
- Significantly reduced switching losses (minimal variation versus temperature) resulting in more compact designs (with smaller passive components)
- Low on-state resistance (80 mΩ typical at 25 °C) resulting in higher system efficiency (reduced cooling requirements)
- Simple to drive (cost-effective network driving)
- Very fast and robust intrinsic body diode (no need for external freewheeling diode, thus more compact systems)

## IGBTs

With breakdown voltages ranging from 350 V to 1300 V, ST's IGBTs feature the optimal trade-off between switching performance and on-state behavior due to their proprietary technology. They enable greater all round energy-efficient system designs in applications such as motor control, photovoltaics, UPS, automotive, induction heating, welding, lighting and others ([www.st.com/igbt](http://www.st.com/igbt)).

Some of the features of our IGBT portfolio are as follows:

- Low  $V_{CE(SAT)}$  for reduced conduction losses
- Improved switch-off energy spread versus increasing temperature resulting in reduced switching losses
- Tight parameter distribution for design simplification and easy paralleling
- Co-packaged, tailored anti-parallel diode option for improved power dissipation and best thermal management

These IGBTs are based on both standard punch-through technology, ideal for white goods, and the newly introduced trench-gate field-stop technology which enables extremely fast turn-off times with minimal tail currents, stable behavior over temperature, and a low  $V_{CE(SAT)}$  that, coupled with the positive de-rating with temperature, improves the applications' efficiency.

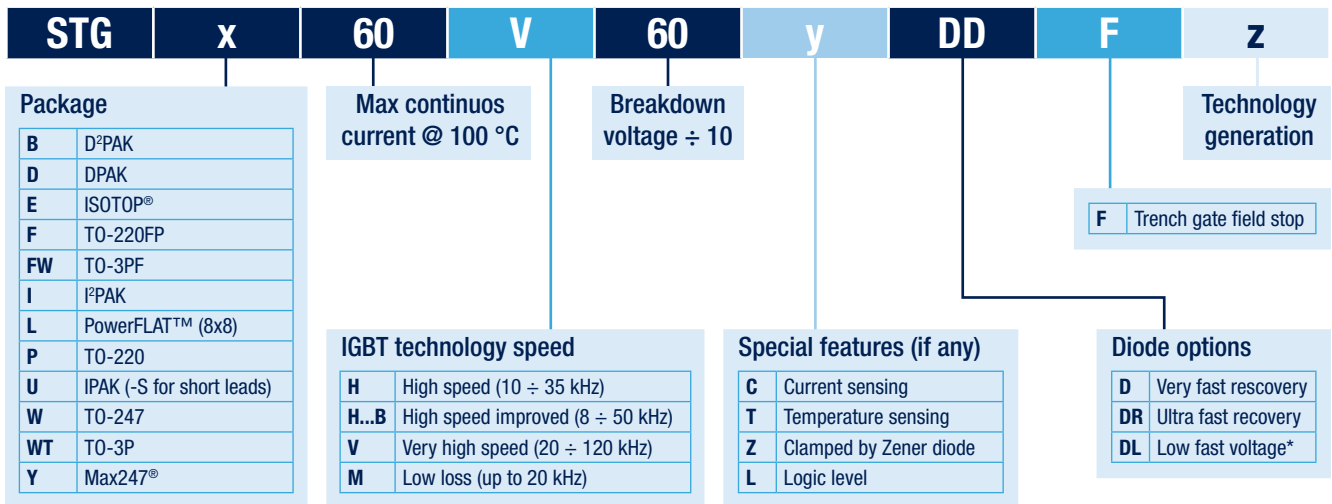

Note: \* For soft-switching applications only

Part number	BV <sub>CES</sub> (V)	I <sub>CN</sub> <sup>1</sup> (A)	V <sub>CE(SAT)</sub> <sup>2</sup> (V)	E <sub>off</sub> <sup>3</sup> (mJ)	Max T <sub>J</sub> (°C)	Switching frequency range	FRD option	Package					
								D <sup>2</sup> PAK	TO-220	TO-247	TO-3P	Max247	TO-3PF
STGx30V60DF	600	30	1.85	0.23	175°C	V (20 - 120kHz)	Very fast	B	P	W	WT		FW
STGx40V60DF	600	40	1.8	0.41	175°C	V (20 - 120kHz)	Very fast			W	WT		FW
STGx60V60DF	600	60	1.85	0.55	175°C	V (20 - 120kHz)	Very fast			W	WT		
STGx40H65DFB	650	40	1.6	0.48	175°C	HB (8 - 50kHz)	Very fast			W	WT		
STGx60H65DFB	650	60	1.6	0.63	175°C	HB (8 - 50kHz)	Very fast			W	WT		
STGx80H65DFB	650	80	1.6	1.2	175°C	HB (8 - 50kHz)	Very fast			W	WT	Y	
STGx15H120DF2	1200	15	2.1	0.45	175°C	H (15 - 50kHz)	Very fast			W			
STGx25H120DF2	1200	25	2.1	0.8	175°C	H (15 - 50kHz)	Very fast			W			
STGx40H120DF2	1200	40	2.1	1.3	175°C	H (15 - 50kHz)	Very fast			W			

Note: 1: I<sub>CN</sub>: IGBT nominal collector current @ T<sub>J</sub> = 100 °C  
2: V<sub>CE(SAT)</sub>: typical conduction losses @ I<sub>CN</sub>, T<sub>J</sub> = 25 °C  
3: E<sub>off</sub>: switching-off energy @ I<sub>CN</sub>, T<sub>J</sub> = 25 °C on capacitive load (33 nF)

Almost 30 through hole packages are available as well as a variety of SMD (surface mounted devices) for our power transistors. For example, the PowerFLATTM 8x8 mm is a leadless SMD package for high-voltage power transistors:

- 64 mm<sup>2</sup> footprint
- Low profile with 1 mm thickness
- Bottom exposed metal drain pad for efficient heat dissipation and improved thermal performances
- Enables end products with greater power density
- Unequalled low R<sub>DS(on)</sub>\* area
- Creepage distance: 2.7 mm
- Operating T<sub>J</sub> between -55 and 150 °C
- Lead finishing: pure tin plating (Sn 100%)
- Halogen free
- RoHS compliant
- MSL level 3
- Suited for wave soldering
- Provided in 13" tape and reel
- Low parasitic inductances



## Diodes

We present here an overview of ST's diode offering. We recommend that you visit [www.st.com/diodes](http://www.st.com/diodes), to get more information. The diagram below gives an idea of how many part numbers are available to fit all application needs.

ST offers Schottky and ultrafast rectifier solutions for all market requirements. ST's latest developments include our M series, based on Schottky technology, with improved avalanche rating and the integration of higher currents in low-profile PowerFLAT™ packages.

Our range of small-signal Schottky diodes with flip-chip and SOD-923 devices helps meet the most stringent space-saving requirements, especially for portable communication equipment.

For high-efficiency rectification or freewheeling functions, our new field effect rectifier diodes, the FERD family, improve the power density capability of the converters.

For power converter applications where silicon diodes reach the limits of their operating temperature and power density, ST's first- and second-generation silicon-carbide devices offer optimal reliability.

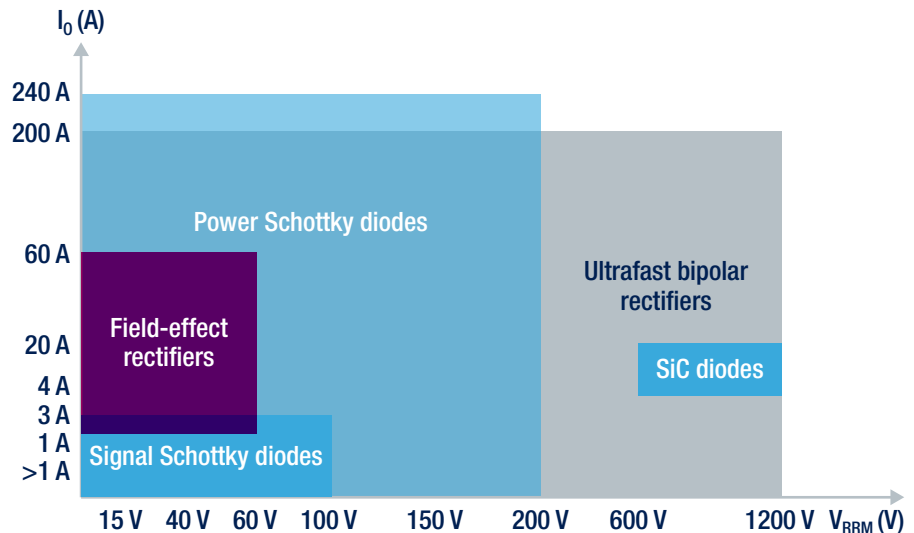

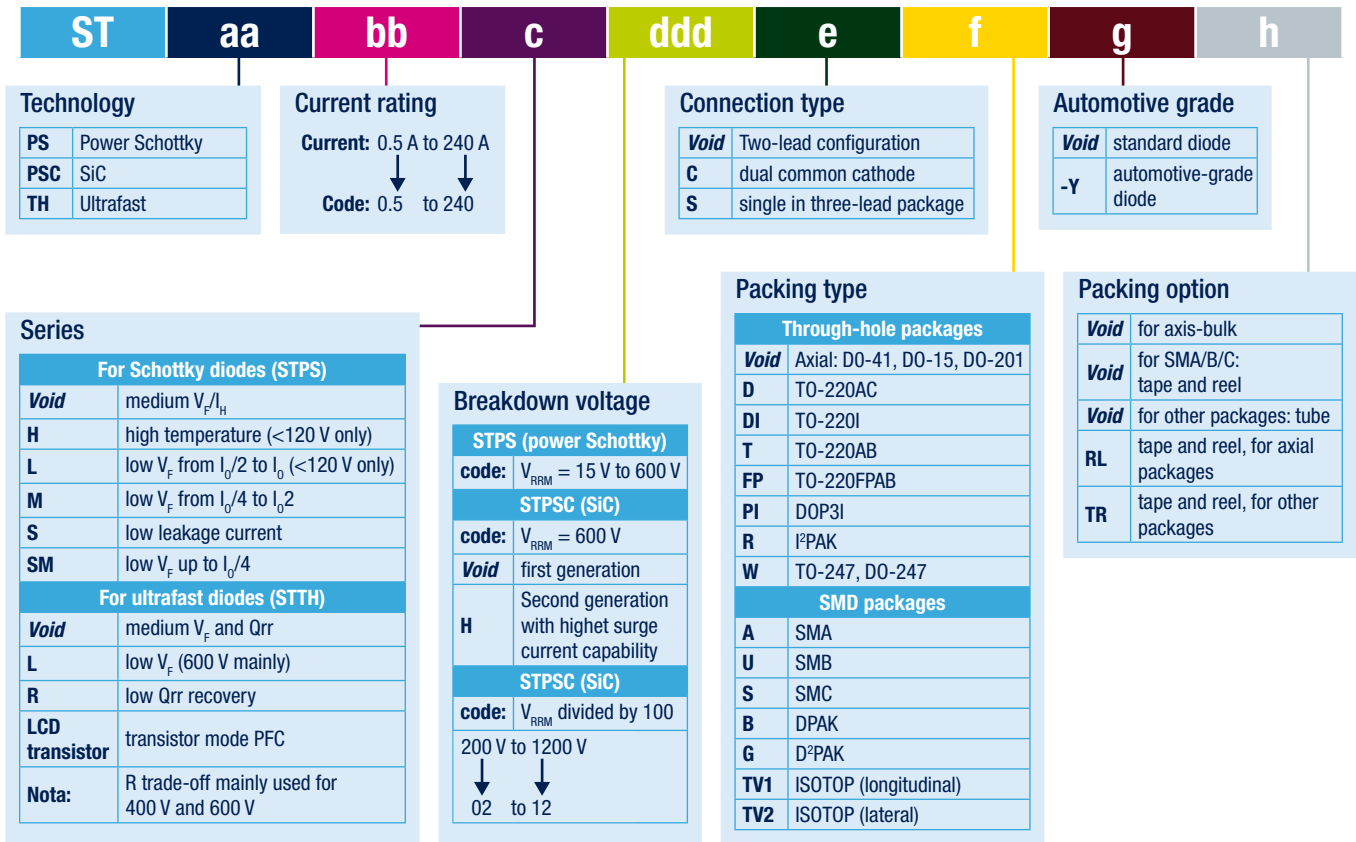

ST's silicon-carbide diodes take advantage of SiC's superior physical characteristics over Si, with 4 times better dynamic characteristics and 15% less forward voltage,  $V_F$ .

Their low reverse recovery characteristics make ST's SiC diodes a key contributor to energy savings in SMPS applications and in emerging domains such as solar energy conversion, EV or HEV charging stations, and other applications such as welding equipment and air conditioners.

ST's SiC product portfolio includes a 20 A, 600 V diode, housed in a halogen-free TO-247 package, to extend its 4- to 12-amp, through-hole and SMD package offer.

ST's silicon-carbide diodes are now entering the second generation, with a 6 A, 1200 V device, and a 650 V series.

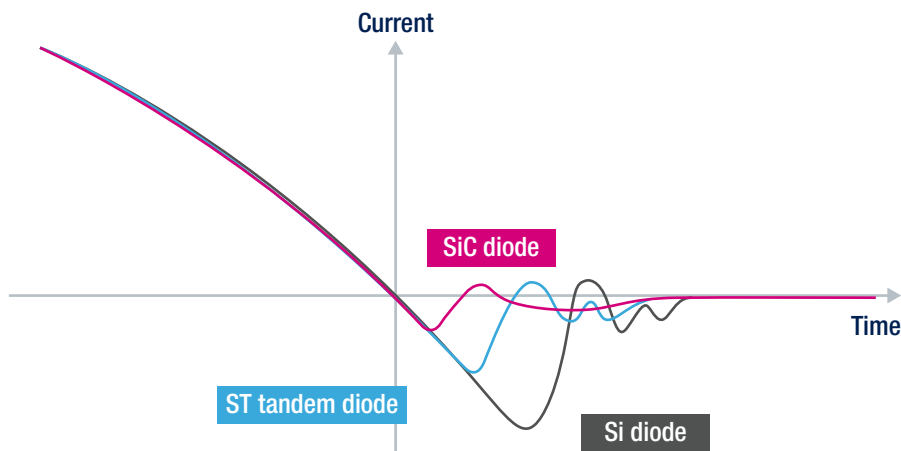

SiC diodes provide zero recovery time with negligible switching losses

## Power modules

Starting from power switches, considered in dice form, ST has also developed power modules (www.st.com/modules).

With the aim of benefitting from device integration and state-of-the-art materials to optimize thermal spread, electrical efficiency and bill of material, ST's offer today is based on molded modules as well as on plastic packages. While the first are useful for powers up to 3 kW and can integrate some intelligence on board, plastic power modules are suited for the industrial environment, and are able to support currents up to 100 A.

The family of small low-loss intelligent molded modules with power up to 3 kW is named SLIMM™.

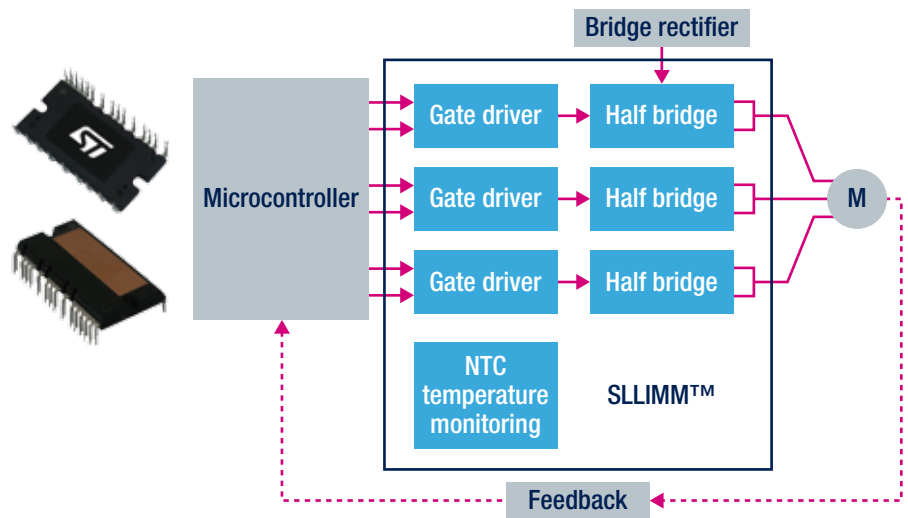

The key features of this first family of power modules are:

- DBC (direct bonded copper) and vacuum soldering process
- Smart shutdown function
- Comparators for fault protection against overcurrent and short circuit
- Integrated bootstrap diodes

- Deadtime and interlocking function
- Undervoltage lock out function
- Op amp for advanced current sensing
- NTC sensor for temperature control

ST's power module offer is enriched with some devices dedicated to the industrial environment. The STA3 power module package is available in Al<sub>2</sub>O<sub>3</sub> DBC as insulating material, a proprietary package with an integrated copper baseplate. It is similar in dimensions to the most common in the market, but with some characteristic making it very attractive, especially from the customization point of view, and a state-of-the-art mechanical robustness (thanks to innovative features introduced in the mechanical screwing of plastic and metallic parts).

Available today in the well-known 6-Pack configuration, with 1200 V, 40 A trench-field stop IGBTs as switches, integrated NTC temperature sensor and shunt resistors to sense the current in each phase of the motor, already embedded in the DBC, the module is proposed also in a press-fit pin package. Dedicated solutions in this package are delivered with a short lead time for first prototypes.



Full traceability of each part is guaranteed per single module. Footprint dimensions are 105.00 x 46.00 x 17.00 mm.

## Gate drivers

ST's success in motor driving is the result of our leadership in SoC (system on chip) solutions for smart power ICs, combined with deep system know-how, design methodology and application expertise. An example is our proprietary BCD technology (bipolar CMOS DMOS), that allows the coexistence of both power and logic in the same chip. A new gapDRIVE™ platform in this technology will soon be available, being the first galvanic isolated gate drivers in ST.

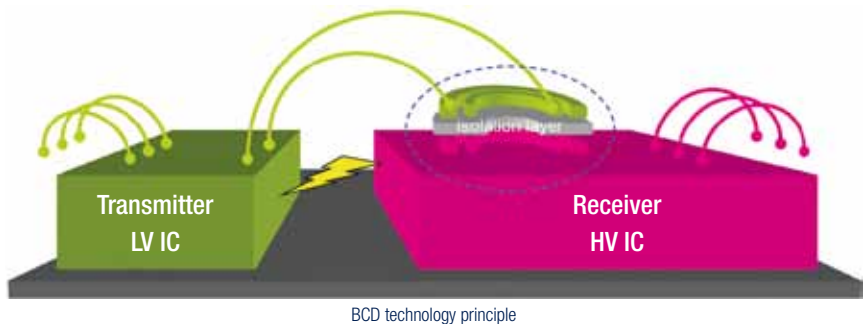

The device is offered for a first evaluation with HW and SW tools, which are available for this first step upon specific request. Some features include:

- Input to output propagation delay: < 150 ns
- High-voltage rail: up to 1.5 kV
- Positive drive voltage: up to 36 V
- Driver current capability: 5 A sink, source current at 25 °C
- SPI interface for parameter programming and diagnostics, daisy chaining possibility
- Active Miller clamp and desaturation detection
- Overcurrent and over-temperature protection
- Output 2-level turn off

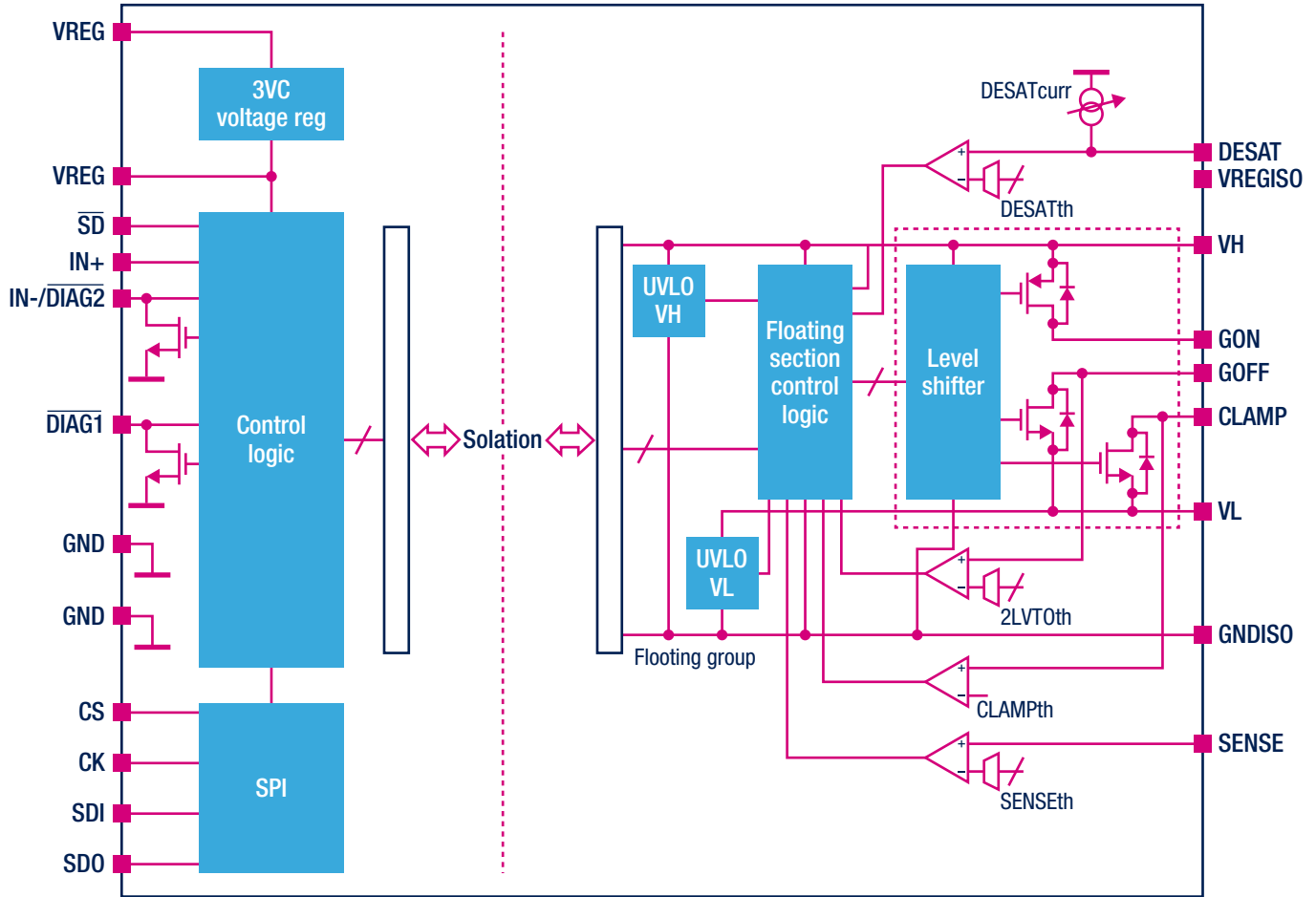

A standard offering of IGBT and MOSFET gate drivers is summarized in the table below.

Part number	Logic interface		V <sub>cc</sub> max (V)	UVLO on V <sub>cc</sub> (V)	UVLO on V <sub>BOOT</sub> (V)	Interlocking - DT (µs)	Op amp	Comparator	# pins
	Input configuration	Configuration							
<b>Half-bridge drivers</b>									
L6384E	Single in, SD	5, 15 V	18	10/12	-	0.5 ÷ 2.7	No	No	8
L6385E	HIN and LIN	5, 15 V	18	8.3/9.6	8.2/9.5	-	No	No	8
L6386E L6386AD	HIN, LIN, SD	5, 15 V	18	10/12 8.3/9.6	9.9/11.9 8.2/9.5	9.9/11.9	No	Yes, uncommitted	14
L6387E	HIN and LIN	5, 15 V	18	5.5/6	-	Interlocking	No	No	8
L6388E	HIN and LIN	3.3, 5, 15 V	18	8.3/9.6	8.2/9.5	0.32	No	No	8
L6390	HIN, LIN, SD	3.3, 5, 15 V	21	10.5/12	10/11.5	0.18 ÷ 3	Yes	Yes, committed to fault + SSD	16
L6391	HIN, LIN, SD	3.3, 5, 15 V	21	10.5/12	10/11.5	0.18 ÷ 3	No	Committed to fault + SSD	14
L6392	HIN, LIN, SD	3.3, 5, 15 V	21	10.5/12	10/11.5	0.18 ÷ 3	Yes	No	14
L6393	Phase, brake, SD	3.3, 5, 15 V	21	8.0/9.5	8/9	0.18 ÷ 3	No	Yes, uncommitted	14
L6395	HIN and LIN	3.3, 5, 15 V	20	8.8/9.5	8/8.6	-	No	No	8
L6398	HIN and LIN	3.3, 5, 15 V	21	8.0/9.5	8/9	0.32	No	No	8
<b>Single-channel drivers</b>									
TD350	Single in (opto/pulse trans compatible)	5 V	26	11	-	-	No	-	14
TD351	Single in (opto/pulse trans compatible)	5 V	26	11	-	-	No	No	8
TD352	Single in (opto compatible)	5 V	26	11	-	-	No	No	8

## Thyristors and AC switches

ST offers a complete range of thyristors and AC switches with voltage ratings up to 1200 V, current ratings up to 120 A and a range of packages from miniature surface-mounted packages to high power dissipation isolated and non-isolated packages ([www.st.com/thyristors](http://www.st.com/thyristors)).

To address the ever increasing number of AC loads in industrial control, ST has developed the T series Triac family. The T series meets both the immunity and high-commutation needs, offering a cost-sensitive solution. Both immunity ( $dV/dt$ ) and commutation capability ( $dI/dt$ ) are specified at 150 °C for the 800 V series, as well low gate current. This last parameter is key, as it helps optimize the power supply and allows direct drive capability through a single resistance between the microcontroller and the Triac, for all 10 mA gate types.

In addition, the trade-off of  $I_{TSM}$  versus immunity and commutation capability is improved. This is one step ahead of the usual offer, and a unique range on the market.

The key T series features are:

- $I_{TRMS}$  from 4 to 16 A
- $V_{DRM}/V_{RRM}$  up to 800 V
- $V_{DSM}/V_{RSM}$  up to 900 V
- $T_J$ 
  - 150 °C @  $V_{DRM}/V_{RRM}$  up to 600 V (dual  $T_J$  devices only)
  - 125 °C for 220 V mains,  $V_{DRM}/V_{RRM}$  up to 800 V (dual  $T_J$  devices only)
- 4 ranges of  $I_{GT}$ 
  - 10 mA directly driven from a microcontroller
  - 20 mA Snubberless™
  - 25 mA standard 4 quadrants
  - 35 mA Snubberless

T series Triacs have better noise immunity ( $dV/dt$ ) up to 2 kV, which is up to 5 times above market standards. Commutation capability, ( $dI/dt$ ), is increased up to 16 A/ms, which is up to 2.3 times above market standards. The table below compares a standard Triac (BTA08-600CWRG) with a T series Triac (T835T-8FP)

Part number	Current $I_{T(RMS)}$ (A)	Immunity $dV/dt$ (w/o snubber) (V/ $\mu$ s)	Commutation ( $dI/dt$ )c (A/ms)
T835T	8	400	4.5
BTA08-600CWRG		2000	8

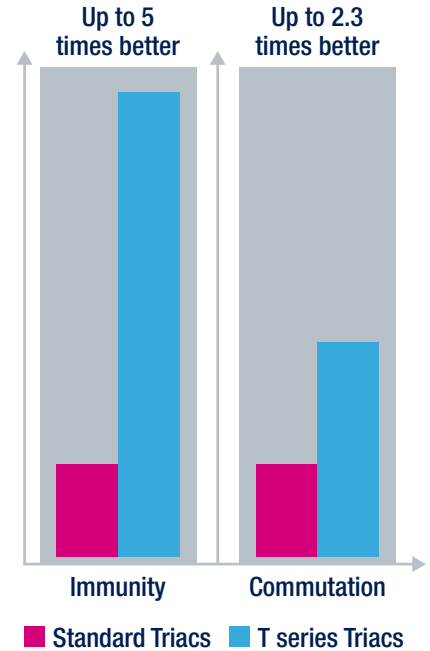

## SIGNAL CONDITIONING

### Operational amplifiers

ST is a reliable high-volume supplier of both standard and high-performance op amps ([www.st.com/opamps](http://www.st.com/opamps)):

- Complete 5 V and 16 V CMOS portfolio including precision and wide bandwidth op amps

- Space-saving packages, such as DFN, QFN, SOT-23 and SC-70

Our JFET, bipolar, CMOS and BiCMOS technologies allow our products to support:

- Wide supply range, from 1.5 V to 36 V
- High ratios of performance-to-power consumption

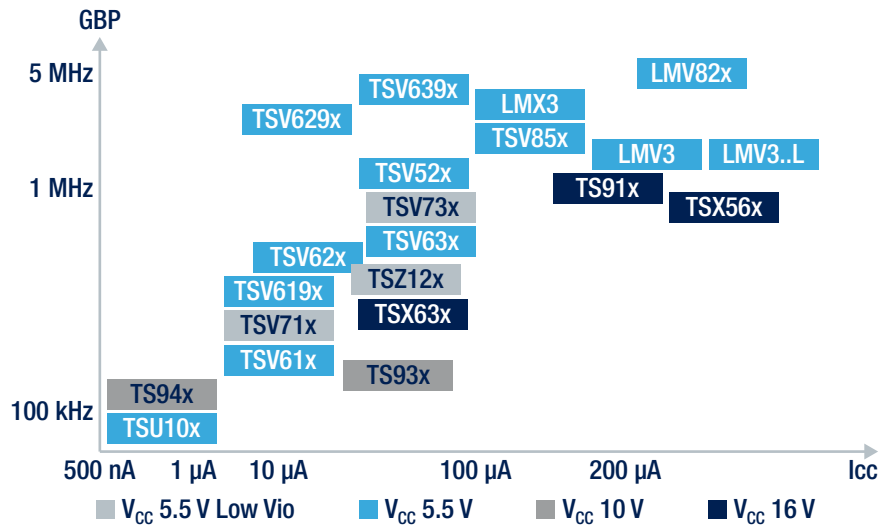

Op-amp series	Main features	Applications
TSV5 – TSV6 TSV8 – TSV9	Micropower, high merit factor, and wideband 5 V CMOS rail-to-rail	Sensor signal conditioning Battery-operated devices
TSV7 – TSZ12x	High precision Micropower 5 V CMOS	Sensor signal conditioning Handheld equipment
TSX5 – TSX6 – TSX7 TSX9	Micropower, high merit factor, wideband and precision 16 V CMOS rail-to-rail Excellent power/bandwidth ratio	Power applications (12 V, 15 V, +/-5 V) AFE for high-voltage sensors



## Comparators

ST is a leading supplier of comparators, and our portfolio offers:

- High-speed comparators, with response times as fast as 8 ns
- Micropower comparators with operating currents as low as 210 nA
- High-temperature (150 °C) qualified devices
- Guaranteed specified min/max electrical performances

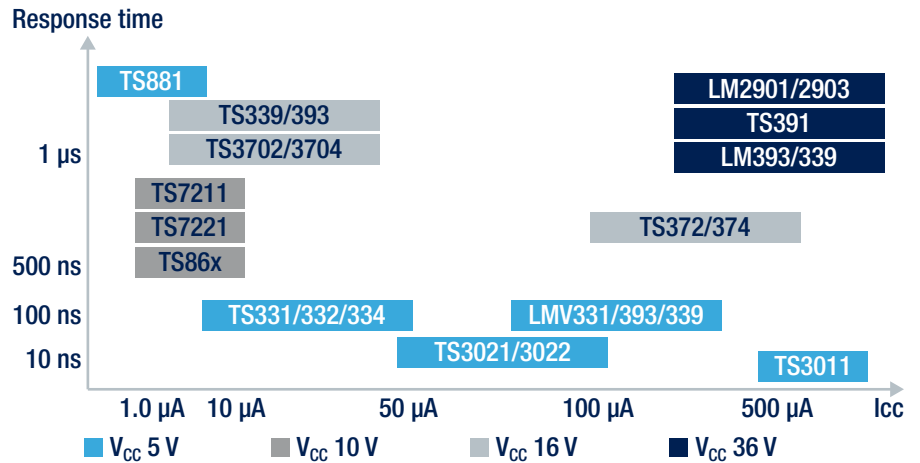

Comparators Highlight	Main features	Applications
TS881	Nanopower Very low voltage	Gas, CO detectors Battery-operated security systems
TS3011	Nano-second response time High efficiency	Optical modules High-frequency systems

## High-side current sensing (TSC series)

Accurate sensing of currents is central to enhancing application safety. Controlling the current within set boundaries avoids overheating and short circuits. Current measurement is also an essential part of energy metering.

The main features of our growing high-side current-sense amplifier portfolio are:

- Up to 70 V line monitoring
- Integrated solutions (for example, inclusion of EMI filtering on output) for faster design times and a reduced BOM
- Robust devices that do not require external protection
- Automotive-grade qualified current-sense amplifiers

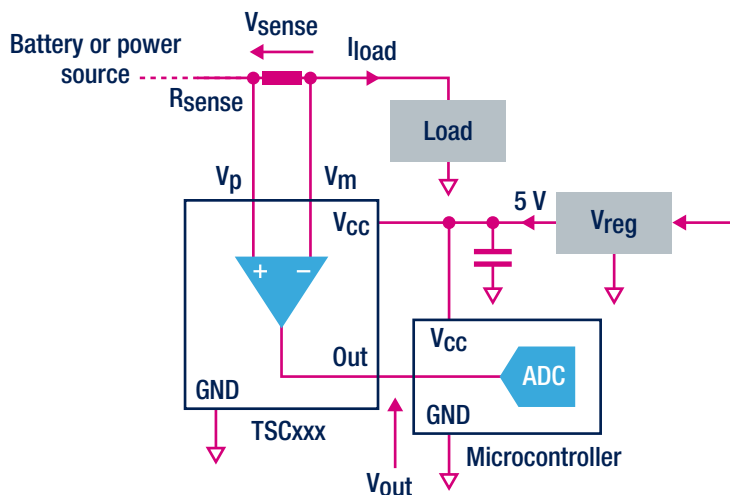

### HIGHLIGHT: TSC103

- Common-mode voltage: 2.9 to 70 V
- Optional dual-supply configuration to reach -2.1 V to 65 V common-mode range
- Rugged input pin sustain -16 to +75 V and 2.5 kV ESD
- Pin-selectable gain: 20 V/V, 25 V/V, 50 V/V, 100 V/V
- Low current consumption: 360 µA

Order code	Description	Documentation
STEVAl-ISQ007V1	High-side current-sense amplifier demonstration board based on TSC101	AN2727
STEVAl-ISQ013V1	Low-side current sensing based on TS507	AN3222

