



# LED Lighting Solutions



*Covering LED drivers, power management, communication, control, and sensing solutions for solid state lighting applications from ON Semiconductor.*



[www.onsemi.com](http://www.onsemi.com)

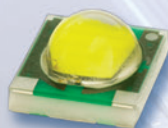
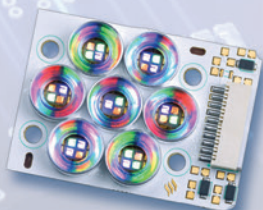

# INTRODUCTION

## **LED Technology**

As the technology and light output of LEDs continues to improve, applications for color and white high-brightness LEDs are expanding into entirely new markets. Once primarily used as indicators, LED cost and performance levels have improved dramatically, allowing them to displace incandescent and fluorescent light sources in automotive applications, consumer electronics ranging from smart phones to LCD-TVs, architectural lighting, and general lighting. Over the next few years, LEDs will continue to transform the lighting marketplace with new and innovative solid state lighting (SSL) solutions that can take advantage of both their programmability and flexibility.

## **Driver Solutions**

LEDs are inherently low voltage devices and depending on the color and current, the forward voltage of the LED can vary from less than 2 to 4.5 V. In addition LEDs need to be driven with a constant current to ensure the intensity and color desired.

This requires power conversion and control solutions to interface to the various power sources, be it the AC line, a solar panel, a 12 V car battery, a DC power supply or low voltage AC system, or even primary Alkaline and Ni-based cells or rechargeable Li-Ion battery cells.

ON Semiconductor has focused on applying our low voltage and high voltage technologies and our expertise in power management solutions to the challenges of solid state lighting; whether in portable display products, interior automotive lighting, or ballast for LED signage. In the following pages, examples will be provided for a number of different applications of solid state lighting for architectural, industrial, automotive and portable applications.



# PORTABLES

## Low-Voltage Portable LED Driver Topologies

White LED and RGB tricolor LEDs are widely used for backlighting small color LCD panels and keyboards, as well as indicators. High brightness LEDs are used as flash light sources in smart phones and digital cameras. These applications require optimized solutions which can maximize battery lifetime, as well as minimize the PCB area and height. ON Semiconductor has a variety of

solutions using linear, inductive, and charge pump topologies. The inductive solution offers the best overall efficiency, while the charge pump solution takes up a minimal amount of space and height due to the use of low profile ceramic capacitors as the energy transfer mechanism. Linear drivers are ideal for color indicator as well as simple backlighting applications.

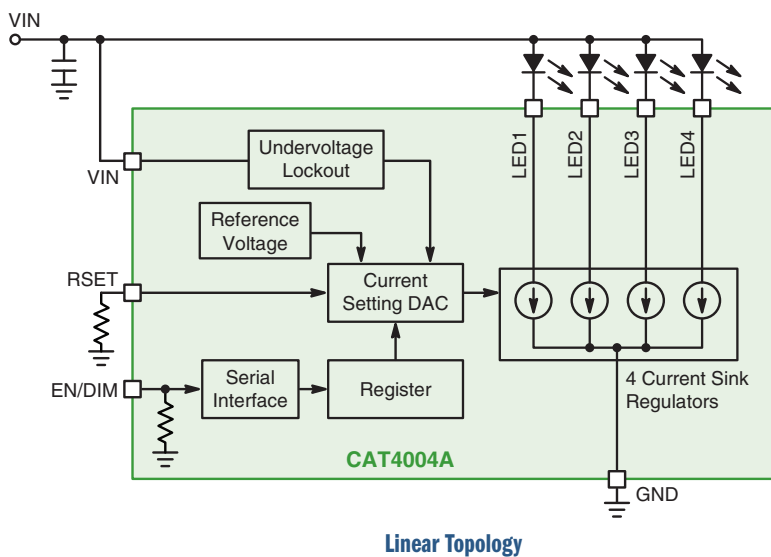
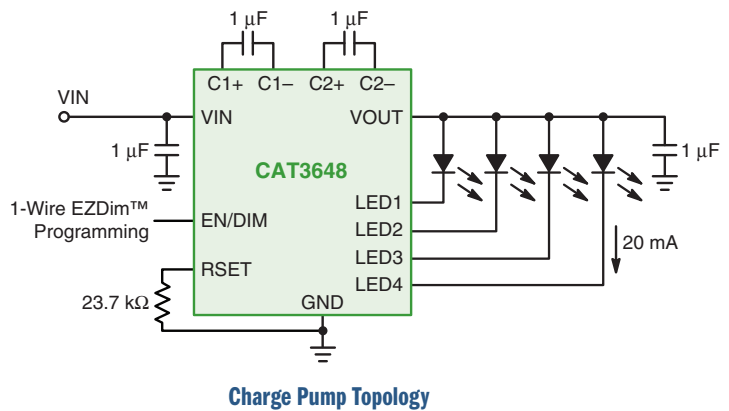
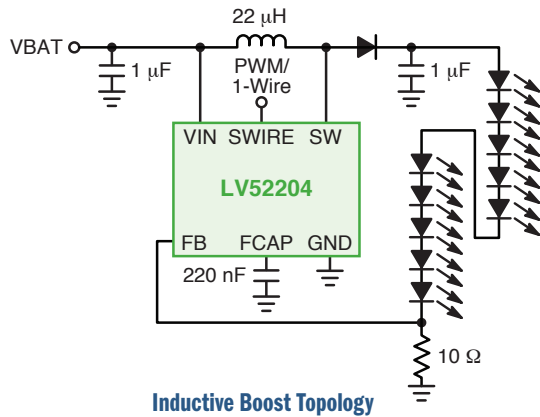

## Charge Pump Topology

Patented Quad-Mode<sup>®</sup> adaptive fractional charge pumps take LED driver performance to a new level by offering a 10% efficiency improvement and up to 65% smaller packaging, without the need for an additional capacitor.

Quad-Mode LED drivers deliver the high efficiency levels normally associated with inductor-based LED drivers, while eliminating the associated high-profile inductors and unwanted EMI. Most charge pump LED drivers offer three modes of operation corresponding to the ratio of the output voltage to the input voltage: 1x, 1.5x and 2x. The Quad-Mode architecture adds a fourth mode of operation, 1.33x, without the need for the additional capacitor required by all other four-mode charge pumps.

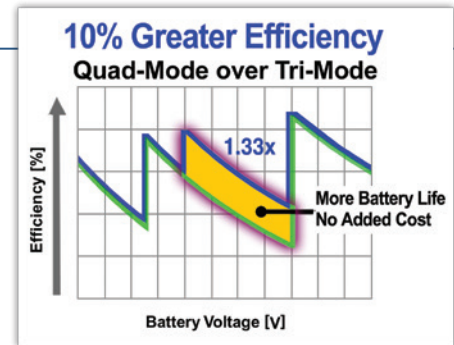

### Features

- 4 charge pump modes: 1x, 1.33x, 1.5x, 2x
- 10% higher efficiency versus 3-mode charge pumps
- No additional capacitors
- No inductor

### Charge Pump/White and RGB LED Drivers – for LCD Backlight, LED Flash/Torch and Indicator

Device	Input Voltage Range (V)	Number of Outputs	Total Output Current (mA)	Regulation Mode	Charge Pump Operating Mode	LED-LED Current Matching, Typ	Dimming Method	Number of Current Level/Profile	Operating Quiescent Current, Typ (mA)	Shutdown Current (µA)	Package	Notes
NCP1840	3.0 - 5.5	8	240	Current	1x / 1.33x / 1.5x / 2x	±2%	I2C	32/ log	2.3	0.12	QFN-20	<ul style="list-style-type: none"> <li>• Indicator application</li> <li>• Individual PWM programmability per channel; 64 different PWM duty cycle settings</li> <li>• Individual current level programmability (32 levels) per channel</li> </ul>
CAT3606	2.7 - 5.5	6	180	Current	1x / 1.5x	±1.5%	PWM	Depends on System	1	1 max	TQFN-16	• Backlight
CAT3616	2.7 - 5.5	6	186	Current	1x / 1.5x	±3%	Single Wire	32	0.5	1 max	TQFN-16	• Backlight
CAT3626	2.7 - 5.5	6	192	Current	1x / 1.5x	±3%	I2C	Depends on System	0.5	1 max	TQFN-16	• Backlight
CAT3636	2.2 - 5.5	6	192	Current	1x / 1.33x / 1.5x / 2x	±1%	Single Wire	32	0.5	1 max	TQFN-16	• Backlight
CAT3637	2.2 - 5.5	6	192	Current	1x / 1.33x / 1.5x / 2x	±1%	Single Wire	16	0.5	1 max	TQFN-16	• Backlight
CAT3649	2.4 - 5.5	6	150	Current	1x / 1.33x / 1.5x / 2x	±1.5%	Single Wire & PWM	32	1.4	1 max	TQFN-16	• Backlight
CAT3604A	2.7 - 5.5	4	120	Current	1x / 1.5x	±3%	PWM	Depends on System	0.3	0.05 typ	TQFN-16	• Backlight
CAT3604V	2.7 - 5.5	4	120	Current	1x / 1.33x / 1.5x / 2x	±1.5%	PWM	Depends on System	1	1 max	TQFN-16	• Backlight
CAT3614	2.7 - 5.5	4	124	Current	1x / 1.5x	±3%	Single Wire	32	0.5	1 max	TDFN-12	• Backlight
CAT3644	2.2 - 5.5	4	100	Current	1x / 1.33x / 1.5x / 2x	±1.5%	Single Wire	6	1	1 max	TQFN-16	• Backlight
CAT3648	2.2 - 5.5	4	100	Current	1x / 1.33x / 1.5x / 2x	±1.5%	Single Wire	32	1	1 max	TQFN-16	• Backlight
NCP5623B/C	2.7 - 5.5	3 (Independent)	90	Current	1X, 2X	±0.5%	I2C	32/ quasi-log	0.35	0.8 typ	LLGA-12	<ul style="list-style-type: none"> <li>• RGB illumination</li> <li>• Backlight</li> <li>• Built-in "gradual illumination"</li> <li>• B &amp; C versions have different I2C addresses</li> </ul>
CAT3643	2.2 - 5.5	3	90	Current	1x / 1.33x / 1.5x / 2x	±1.5%	Single Wire	6	1	1 max	TDFN-12, TQFN-16	• Backlight

## Charge Pump/White and RGB LED Drivers – for LCD Backlight, LED Flash/Torch and Indicator (cont.)

Device	Input Voltage Range (V)	Number of Outputs	Total Output Current (mA)	Regulation Mode	Charge Pump Operating Mode	LED-LED Current Matching, Typ	Dimming Method	Number of Current Level/Profile	Operating Quiescent Current, Typ (mA)	Shutdown Current, (µA)	Package	Notes
CAT3647	2.2 - 5.5	3	100	Current	1x / 1.33x / 1.5x / 2x	±1.5%	Single Wire	32	1	1 max	TQFN-16	• Backlight
CAT3612	3.0 - 5.5	2	300	Current	1x / 1.5x	±3%	Single Wire	32	0.5	1 max	TDFN-12	• Flash/Torch
CAT3224	2.0 - 5.5	2	4 A Flash, 400 mA Torch	Current	1x / 2x	–	–	–	6	1 max	TQFN-16	• Flash/Torch
NCP5612	2.7 - 5.5	2	60	Current	1X, 1.5X	±0.2%	S-Wire Link (Single Wire Serial Link)	16/ linear	0.6	1	LLGA-12	• Built-in “icon” dimming mode • OVP • Short circuit protection
CAT3661	2.0 - 5.5	1	10	Current	1x / 1.33x / 1.5x / 2x	–	–	–	0.13	1 max	TQFN-16	• Built-in “icon” dimming mode • Optimized for coin cell applications
NCP5603	2.85 - 5.5	1	200 mA DC, 350 mA pulse	Voltage	1X, 1.5X, 2X	–	PWM	Depends on system	1	2.5 typ	DFN-10	• Backlight • 4.5 / 5 V output • Short circuit protection
CAT3200	2.7 - 4.5	1	100	Voltage	2X	–	PWM	Depends on system	1.7	1 typ	TSOT-23-6	• Backlight • 2 MHz switching • Soft-start • Thermal shutdown
CAT3200H	2.7 - 4.5	1	100	Voltage	2X	–	PWM	Depends on system	1.7	1 typ	UDFN-8	• Backlight • 2 MHz switching • Soft-start • Thermal shutdown • Fixed $V_{out} = 5$ V and adjustable output



## Inductive Boost and Buck Topology

### Inductive-Boost White-LED Drivers – for Backlighting and Torch/Flash Applications

Device	Input Voltage Range (V)	Max Output Volt, Typ (V)	Output Current (mA)	Condition	Number of LEDs/ Configuration	Switching Mode/ Frequency	Dimming Method	Efficiency (%)	Operating Quiescent Current, Typ (mA)	Shutdown Current, Typ (µA)	Package	Notes
NCP1422	1.0 - 5.0	5	800	Vout 3.3 V, Vin 2.5 V	1 for flash	PFM, up to 1.2 MHz	PWM	94	1.3 µA	0.05	DFN-10	<ul style="list-style-type: none"> <li>Flash/Torch</li> <li>Internal synchronous rectification</li> </ul>
CAT37	2.5 - 7	20	20	Vout =10.8 V	1 to 4 / Series	1.2 MHz	PWM	84	0.5	1	TSOT23-5	<ul style="list-style-type: none"> <li>Backlight</li> <li>LT1937 pinout</li> <li>Isw = 550 mA</li> </ul>
CAT32	2.0 - 7	20	20	Vout =14 V	1 to 4 / Series	1.2 MHz	PWM	84	0.5	0.05	TSOT23-6 / TDFN-8	<ul style="list-style-type: none"> <li>Backlight</li> <li>LT1932 pinout</li> <li>Isw = 550 mA</li> </ul>
CAT4137	2.2 - 5.5	24	40	Vout 17 V, Vin 3.5	1 to 5 / Series	1 MHz	PWM	87	0.4	0.1	TSOT23-5	<ul style="list-style-type: none"> <li>Backlight</li> <li>Isw = 350 mA</li> </ul>
CAT4139	2.0 - 5.5	24	50	Vout 14 V, Vin 3.0	1 to 5 / Series	1 MHz	PWM	87	0.6	0.1	TSOT23-5	<ul style="list-style-type: none"> <li>Backlight</li> <li>Isw = 850 mA</li> </ul>
NCP5005	2.7 - 5.5	24	40	Over 5 LED, Vin 3.6 V	2 to 5/ series	PFM, up to 2.25 MHz	PWM	90	–	0.3	TSOP-5	<ul style="list-style-type: none"> <li>Backlight</li> <li>Isw = 350 mA</li> </ul>
CAT4237	2.0 - 5.5	34	30	Vout 30 V, Vin 3.6	1 to 8 / Series	1 MHz	PWM	87	0.6	0.1	TSOT23-5	<ul style="list-style-type: none"> <li>Backlight</li> <li>Isw = 450 mA</li> </ul>
CAT4238	2.0 - 5.5	38	20	Vout 33 V, Vin 3.5	1 to 10 / Series	1 MHz	PWM	87	0.6	0.1	TSOT23-5	<ul style="list-style-type: none"> <li>Backlight</li> <li>Isw = 450 mA</li> </ul>
CAT4240	2.0 - 5.5	38	250	Vout 30 V, VL 13 V, Vin 5 V	1 to 10 / Series	1 MHz	PWM	87	0.6	0.1	TSOT23-5	<ul style="list-style-type: none"> <li>Backlight</li> <li>Isw = 850 mA</li> </ul>
LV52204	2.7 - 5.5	40	30	Vout 30 V, Vin 3.7 V	2 to 10 / Series	600 kHz	1-wire & PWM	90	3	0.1	UDFN-6	<ul style="list-style-type: none"> <li>Backlight</li> <li>Isw = 750 mA</li> </ul>
LV52206	2.7 - 5.5	40	30	Vout 30 V, Vin 3.7 V	2 to 10 / Series	600 kHz	1-wire & PWM	90	3	0.1	WLP-9	<ul style="list-style-type: none"> <li>Backlight</li> <li>Isw = 750 mA</li> </ul>

### Inductive-Buck White-LED Drivers – for Torch/Flash Applications

Device	Input Voltage Range (V)	Max Output Volt, Typ (V)	Output Current (A)	Condition	Number of LEDs/ Configuration	Switching Mode/ Frequency	Dimming Method	Efficiency (%)	Operating Quiescent Current, Typ (µA)	Shutdown Current, Typ (µA)	Package	Notes
NCP1529	2.7 - 5.5	3.9	1	Vout 1.2 V, Vin 3.6 V	1	PWM/PFM 1.7 MHz	PWM	96	28	0.3	TSOP-5, uDFN-6	<ul style="list-style-type: none"> <li>Flash/Torch</li> <li>Auto-switching between PWM and PFM mode at light load</li> </ul>

## Linear Topology

### Features

- Dimming via 1-wire EZDim interface with 32 levels of dimming control
- 25 mA fixed current (B versions) or adjustable current (A versions)
- Zero current shutdown ( $< 1 \mu\text{A}$ )
- No switching supply noise
- Tightly matched current LED sinks
- Ultra-low headroom current sink
- Dropout voltage of 75 mV at 20 mA
- Low profile micro packaging

### Applications

- Mobile handsets
- Still and video cameras
- Portable gaming
- Portable medical devices

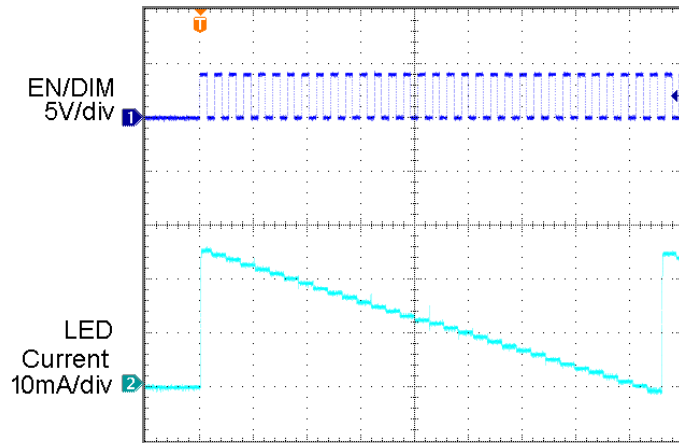

32-Step EZDim Control

### Linear White-LED Drivers for LCD Backlight

Device	No of Channels	Current		Available Packages		
		Fixed (25 mA)	Adjustable (2 to 40 mA)	SC-70-6	TSOT-23-6	UDFN-8
CAT4002A	2		✓	✓	✓	
CAT4003B	3	✓		✓	✓	
CAT4004A	4		✓			✓
CAT4004B	4	✓				✓

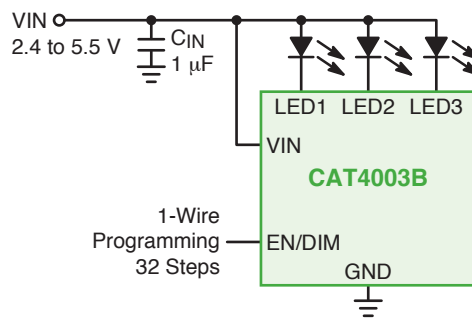

## Camera Flash and Torch Light-Dedicated LED Drivers

LEDs for camera phones, smart phones, and XENON bulb replacement, are scaling up in light output to meet the needs of higher performance camera imagers.

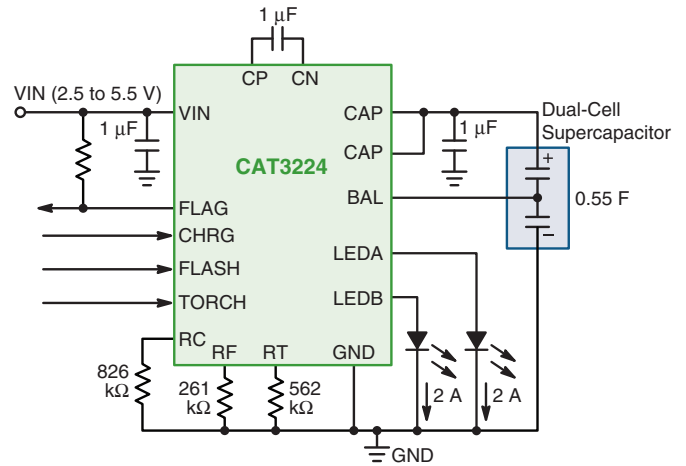
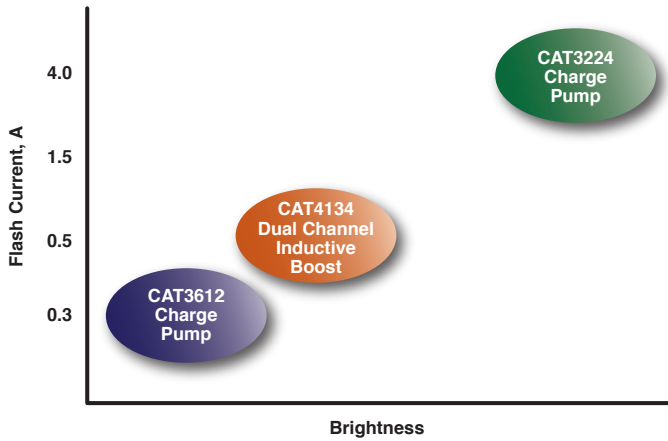

### Camera Flash and Torch Light-Dedicated LED Drivers

Device	Topology	Input Voltage Range (V)	Output Current	Output	Package	Notes
CAT3224	Charge Pump	2.5 - 5.5	2 channels at 2 A each in Flash mode (4 A total); 2 channels at 200 mA each in Torch mode	2 channels	TQFN-16	• Dual Cell Supercapacitor Balancing
CAT4134	Inductive Boost	2.8 - 4.2	250 mA per channel	2 channels (up to 3 LEDs in series per channel)	TDFN-12	• Dual Frequency Mode 1.2 MHz and 900 kHz
CAT3612	Charge Pump	3.0 - 5.5	150 mA per channel	2 channels	TDFN-12	• 1-wire EZDim programmable LED current with 32 dimming levels • Efficiency up to 90%





## Multifunction LED Drivers

### Multifunction LED Drivers

Device	Input Voltage Range (V)	Main Backlight LED Driver	RGB LED Driver 1	External Control	Auto Blinking	Topology	Serial Control	Package	Notes
LV5207LP	3.0 to 4.5	4-Ch (3-Ch Avail)	R,G,B Independent ON/OFF	✓		Charge Pump	I2C Control Bus	VCT-24	<ul style="list-style-type: none"> <li>7 LED channels total</li> <li>LED current programmable in 32 steps</li> </ul>
LV5216CS	3.0 to 4.5	6-Ch (3/4/5-Ch Avail)	R,G,B Independent ON/OFF	✓	✓	Charge Pump	I2C Control Bus	WLP-36	<ul style="list-style-type: none"> <li>7 LED channels total</li> <li>LED current programmable:                             <ul style="list-style-type: none"> <li>- MB, RGB: 32 steps</li> <li>- Auto Luminance Control: 128 steps</li> </ul> </li> <li>Main LED auto luminance control</li> <li>External brightness control</li> </ul>

## RGB Illumination Drivers

### RGB Illumination LED Drivers

Device	Input Voltage Range (V)	RGB LED Driver #1	RGB LED Driver #2	No of Channels	Auto Blinking	Camera Flash LED Driver	Interface	Package	Notes
LV5217LP	3.0 to 4.5	3-channels with independent ON/OFF of the RGB colors	—	3	—	—	I2C	VCT-16	<ul style="list-style-type: none"> <li>Individual current level programmability (128 levels) per channel</li> <li>25 mA total for the 3 channels</li> </ul>
LV5223GR	3.0 to 4.5	3-channels with independent ON/OFF of the RGB colors	3-channels with independent ON/OFF of the RGB colors	9	✓	2-Ch (R2, G2 Common)	I2C	VCT-28	<ul style="list-style-type: none"> <li>Built-in Charge Pump</li> <li>3 additional outputs GPO</li> </ul>

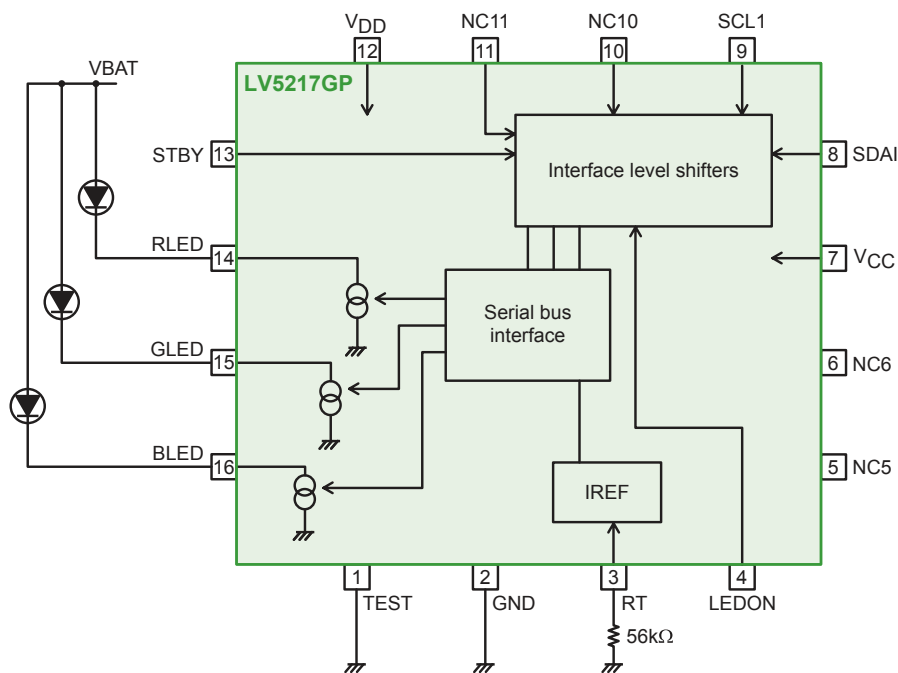

LV5217GP Block Diagram

# ADDRESSABLE SIGNAGE

## Intelligent LED Control for Signage and Architectural Lighting

Addressable signage and architectural lighting make wide use of LEDs utilizing the broad range of available LED colors and their long operating lifetime. In architectural lighting, the use of LEDs allows vivid colors in lighting facades and enhancement of structural details. In moving signage

applications, information can be updated in real time traffic displays, video images, and advertising. ON Semiconductor offers a series of linear solutions that can accurately regulate LED current and have programmable interfaces to allow software control.

### LED Controllers

Device	Vin (V)	LEDs	Iout per Channel (mA)	Dropout Voltage (mV)	Shutdown Current Max (µA)	Dimming Interface	Features	Packages	Architectural	Signage
CAT310	5.5	10	50	–	–	4-Wire	–	SOIC-20		
CAT4008	3.0 - 5.5	8	100	300 @ 30 mA	1	4-Wire	Thermal Shutdown; UVLO	SOIC-16, TSSOP-16		✓
CAT4016	3.0 - 5.5	16	100	300 @ 30 mA	1	4-Wire	Thermal Shutdown; UVLO; Up to 6 V operation on LED pins	QSOP-24, SOIC-24, TQFN-24, TSSOP-24		✓
CAT4116*	3.0 - 5.5	16	100	300 @ 20 mA	1	4-Wire	Thermal Shutdown; UVLO ; Up to 25 V operation on LED pins	TSSOP-24	✓	✓
CAT4101	3.0 - 5.5/25	8	1000	500 @ 1 A	1	PWM	Thermal Shutdown; UVLO	T0-263-5	✓	
CAT4103	3.0 - 5.5/25	6 x 3	175	400 @ 175 mA	1	4-Wire	3 Independent Current Sinks; Cascadable	SOIC-16	✓	
CAT4104	3.0 - 5.5/25	6 x 4	175	400 @ 175 mA	1	PWM	Thermal Shutdown; UVLO	SOIC-8, TDFN-8	✓	
CAT4109	3.0 - 5.5/25	6 x 3	175	400 @ 175 mA	5	PWM	3 Independent Current Sinks	SOIC-16	✓	

\* Pending 1H14.

## 8 and 16 Channel Constant Current LED Sink Drivers

### Features

- ±1.5% typical channel matching
- Up to 100 mA drive per channel
- 300 mV dropout at 30 mA
- Robust protection (UVLO, thermal shutdown)
- Cascadable 25 MHz capable 4-wire data interface

### Applications

- Intelligent vehicle signs
- Scrolling banners
- Billboard signs
- Marque signs
- Gaming and pachinko
- Sports scoreboards

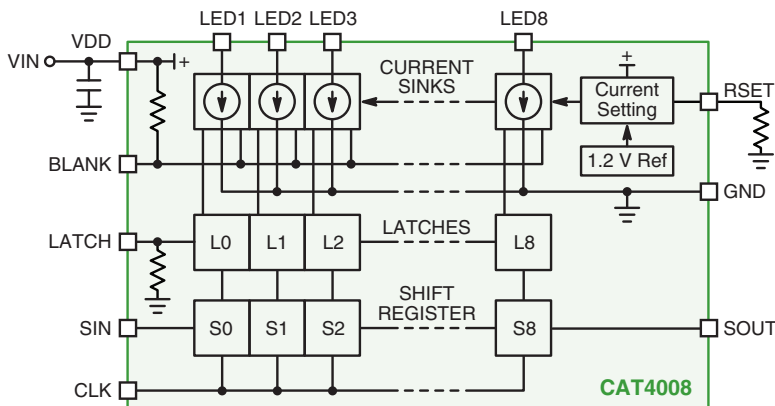

### 3-Channel Cascade-Capable Driver with Independent Current Control – CAT4103

**Features**

- Up to 25 V per string
- Robust protection (UVLO, thermal shutdown)
- RGB Drivers can be individually controlled or cascaded
- Drivers to support currents of up to 175 mA per channel

**Applications**

- Accent lighting
- Color mixing
- Effects lighting
- Mood lighting



**Resources**

- Evaluation Board: CAT4103AEVB

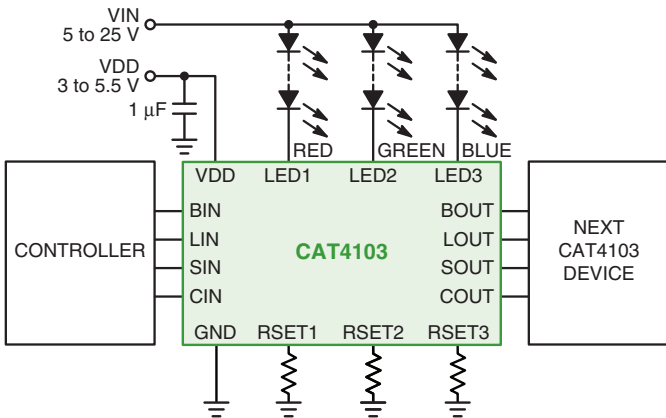
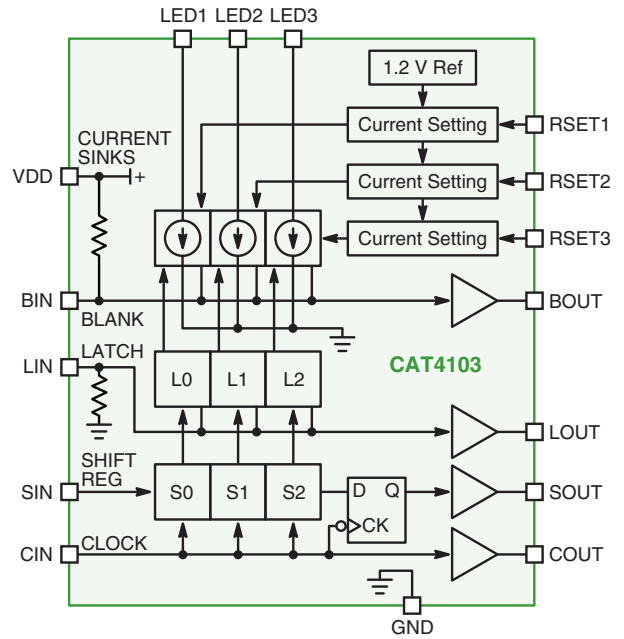

ADDRESSABLE SIGNAGE

## 16-Channel I<sup>2</sup>C LED Indicator Driver and Port Expander – CAT9532 & CAT9552

### Features

- 16 LED drivers with dimming control
- 256 brightness steps
- 16 open drain outputs drive 25 mA each
- Programmable blink rates
- I/Os can be used as general purpose I/Os
- 400 kHz I<sup>2</sup>C bus compatible
- 8 address expansion selections

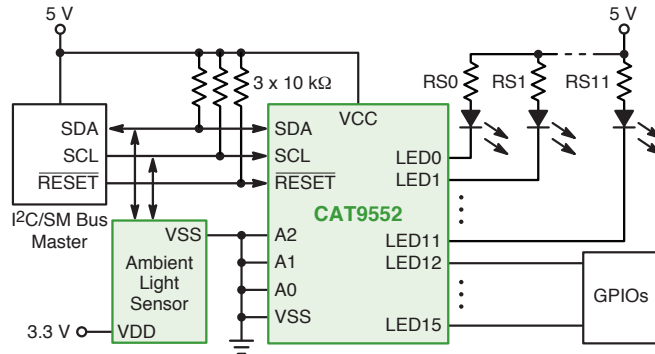

### Applications

- Single board computers
- Telecom equipment
- Office machines
- Appliance control panels
- Gaming
- Alarm systems
- Point of sale displays



# MID-VOLTAGE GENERAL LIGHTING

## Mid-Voltage LED Driver Topologies

Many LED applications are powered from an offline AC-DC supply, a battery, or an electronic transformer with a low voltage AC output. In addition, some of these power sources, such as lead acid batteries, are loosely regulated. As a result, there is a need for LED driver solutions that can operate over a broad

range of input voltage and can be configured in various topologies to support the LED load requirements. Depending on the LED current and operating conditions, this could involve either a linear or switching regulator LED driver solution.

### Applications

- Landscape lighting
- Low voltage track lighting
- Solar powered lighting
- Automotive
- Emergency vehicles
- Marine applications
- 12 Vac/Vdc MR16
- Airplane interiors
- Sign backlighting
- Channel letters and signs

Power	Application	Voltage & Regulation
Offline AC Regulated Adapter	Low to medium volume applications, reduces safety requirements	Common voltages of 12, 24, 36, 48 Vdc, regulation to $\pm 5\%$
(Sealed) Lead Acid Battery	Automotive, solar powered, marine	Loose regulation, 8-14 Vdc; Wider for automotive, 7-27 Vdc
12 Vdc & 12 Vac	Common in interior, track lighting, outdoor, landscaping applications	Loose if magnetic ballast, tight to $\pm 5\%$ if electronic ballast, minimum load may be required; plus cable losses

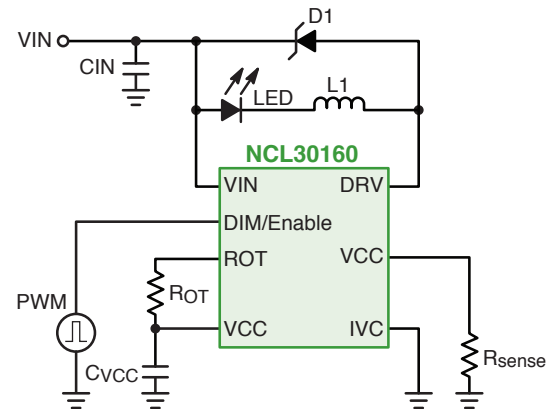

**Buck (Step-Down) Topology**

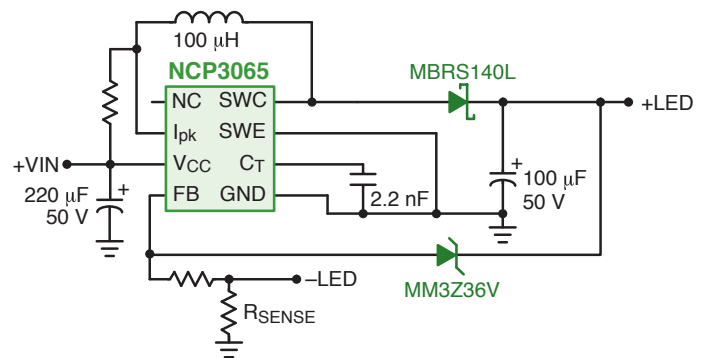

**Boost (Step-Up) Topology**

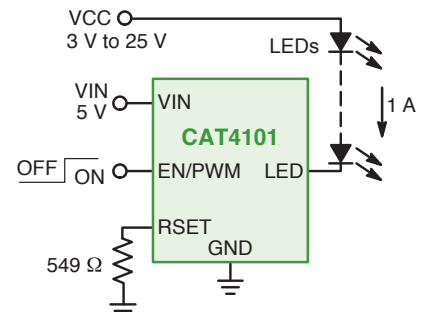

**Linear Topology**

MID-VOLTAGE  
GENERAL LIGHTING

## Linear LED Driver Solutions

Linear solutions are the preferred approach for many lighting applications, as they are simple, straightforward to design, and allow the LEDs to be driven with a tightly regulated current, regardless of LED forward voltage or input supply variation.

Because the LED drivers are linear, they must be matched to the power dissipation requirements of the application. ON Semiconductor offers a wide range of constant current linear LED drivers whose current levels span from 10 mA to 1 A.

### Constant Current Regulators - Dimming with External BRT

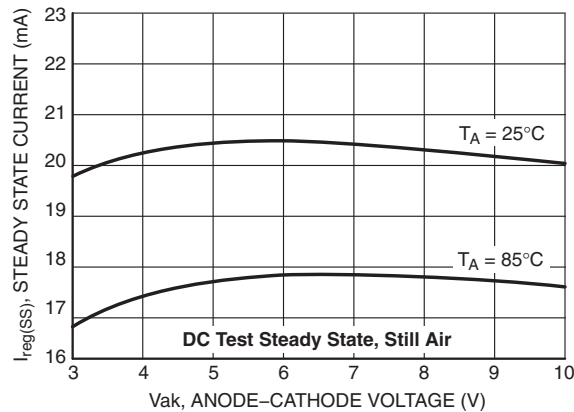
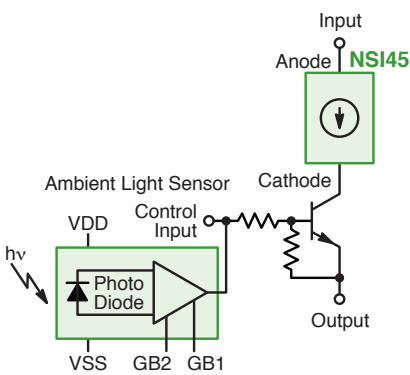

### Linear LED Drivers

Device	Operating Voltage Range (V)	Channel Output Current (mA)	Typical Current Tolerance	Number of Channels	Adjustable	Dimming Control	Typical Dropout (V)	Operating Temperature Range (°C)	Package(s)	Features
CAT4101	3.0 to 25	1000	±2%	1	Y	PWM	500 mV @ 1000 mA	-40 to +85	D2PAK	Thermal Shutdown, UVLO
CAT4104	3.0 to 25	175	±2%	4	Y	PWM	400 mV @ 175 mA	-40 to +85	SOIC-8, TDFN-8	Thermal Shutdown, UVLO
NCV7680	6 to 16	35	±10% @ 35 mA	8	Y	Ext	1	-40 to +125	SOIC-16 EP	AEC-Q101 qualified
NSI50350AS	1.8 to 50	350	±10%	1	N	Ext	1.8	-40 to +125	SMC	AEC-Q101 qualified
NSI50350AD	1.8 to 50	350	±10%	1	N	Ext	1.8	-40 to +125	DPAK	AEC-Q101 qualified
NSIC2050B	1.8 to 120	50	±15%	1	N	Ext	1.8	-40 to +125	SMB	AEC-Q101 qualified
NSIC2030B	1.8 to 120	30	±15%	1	N	Ext	1.8	-40 to +125	SMB	AEC-Q101 qualified
NSIC2020B	1.8 to 120	20	±15%	1	N	Ext	1.8	-40 to +125	SMB	AEC-Q101 qualified
NSI45030Z	1.8 to 45	30	±15%	1	N	Ext	1.8	-40 to +125	SOT-223	AEC-Q101 qualified
NSI45030AZ	1.8 to 45	30	±10%	1	N	Ext	1.8	-40 to +125	SOT-223	AEC-Q101 qualified
NSI45030A	1.8 to 45	30	±10%	1	N	Ext	1.8	-40 to +125	SOD-123	AEC-Q101 qualified
NSI45030	1.8 to 45	30	±15%	1	N	Ext	1.8	-40 to +125	SOD-123	AEC-Q101 qualified
NSI45025Z	1.8 to 45	25	±15%	1	N	Ext	1.8	-40 to +125	SOT-223	AEC-Q101 qualified
NSI45025AZ	1.8 to 45	25	±10%	1	N	Ext	1.8	-40 to +125	SOT-223	AEC-Q101 qualified
NSI45025A	1.8 to 45	25	±10%	1	N	Ext	1.8	-40 to +125	SOD-123	AEC-Q101 qualified
NSI45025	1.8 to 45	25	±15%	1	N	Ext	1.8	-40 to +125	SOD-123	AEC-Q101 qualified
NSI45020A	1.8 to 45	20	±10%	1	N	Ext	1.8	-40 to +125	SOD-123	AEC-Q101 qualified
NSI45020	1.8 to 45	20	±15%	1	N	Ext	1.8	-40 to +125	SOD-123	AEC-Q101 qualified

Linear LED Drivers (cont.)

Device	Operating Voltage Range (V)	Channel Output Current (mA)	Typical Current Tolerance	Number of Channels	Adjustable	Dimming Control	Typical Dropout (V)	Operating Temperature Range (°C)	Package(s)	Features
NSI45015W	1.8 to 45	15	±20%	1	N	Ext	1.8	-40 to +125	SOD-123	AEC-Q101 qualified
NSI50010Y	1.8 to 50	10	±30%	1	N	Ext	1.8	-40 to +125	SOD-123	AEC-Q101 qualified
NSI50150AD	1.8 to 50	150 to 350	±10%	1	Y	Ext	1.8	-40 to +125	DPAK	AEC-Q101 qualified
NSI45090JD	1.8 to 45	90 to 160	±15%	1	Y	Ext	1.8	-40 to +125	DPAK	AEC-Q101 qualified
NSI45060JD	1.8 to 45	60 to 100	±15%	1	Y	Ext	1.8	-40 to +125	DPAK	AEC-Q101 qualified
NSI45035JZ	1.8 to 45	35 to 70	±15%	1	Y	Ext	1.8	-40 to +125	SOT-223	AEC-Q101 qualified
NSI45020JZ	1.8 to 45	20 to 40	±15%	1	Y	Ext	1.8	-40 to +125	SOT-223	AEC-Q101 qualified
NUD4001	2.0 to 30 (60 V Surge)	500	±3%	1	Y	Ext	1.4	-40 to +125	SOIC-8	Can be used with an external transistor
NUD4011	5 to 200	70	±3%	1	Y	Ext	5	-40 to +125	SOIC-8	Can be used with an external transistor

Constant Current Regulator (CCRs) Linear LED Drivers for Displays and Channel Letters

Features

- Low startup voltage
- Tight current regulation regardless of  $V_f$  variation
- Negative temperature coefficient protects LEDs

Resources

- Sample Kit: CCR2KIT/S

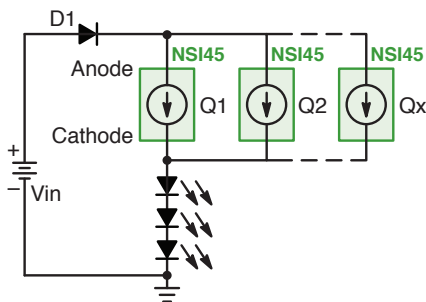

Device	Max Anode-to-Cathode Voltage ( $V_{AK}$ ) (V)	Voltage Overhead ( $V_{in} - V_{LEDs}$ ) (V)	Constant Current $I_{reg}$ (@ $V_{AK} = 7.5 V$ ) (mA)	Current Tolerance Over Voltage	Max Junction Temperature (°C)	Packages
NSI45xxx	45	1.8	Fixed: 15, 20, 25, 30	±15%, ±10%	150	SOD-123, SOT-223
NSI50xxx	50	1.8	Fixed: 10, 350	±10%	175	SMC, DPAK
NSIC20xx	120	1.8	Fixed: 20, 30, 50	±15%	175	SMB
NSI45xxxJ	45	1.8	Adjustable: 20 to 40, 35 to 70, 60 to 100, 90 to 160	±15%	150	SOT-223, DPAK
NSI50150AD	50	1.8	150 to 350	±10%	175	DPAK

NOTE: xxx in the device number represents the current level.

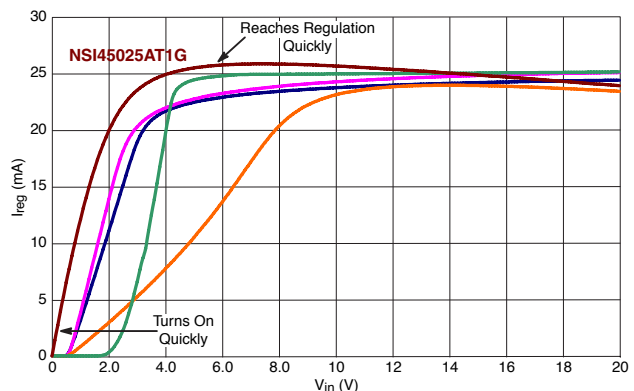

NSI45025 vs Competing Devices @ 25 mA

MID-VOLTAGE GENERAL LIGHTING

## Switching Driver Solutions

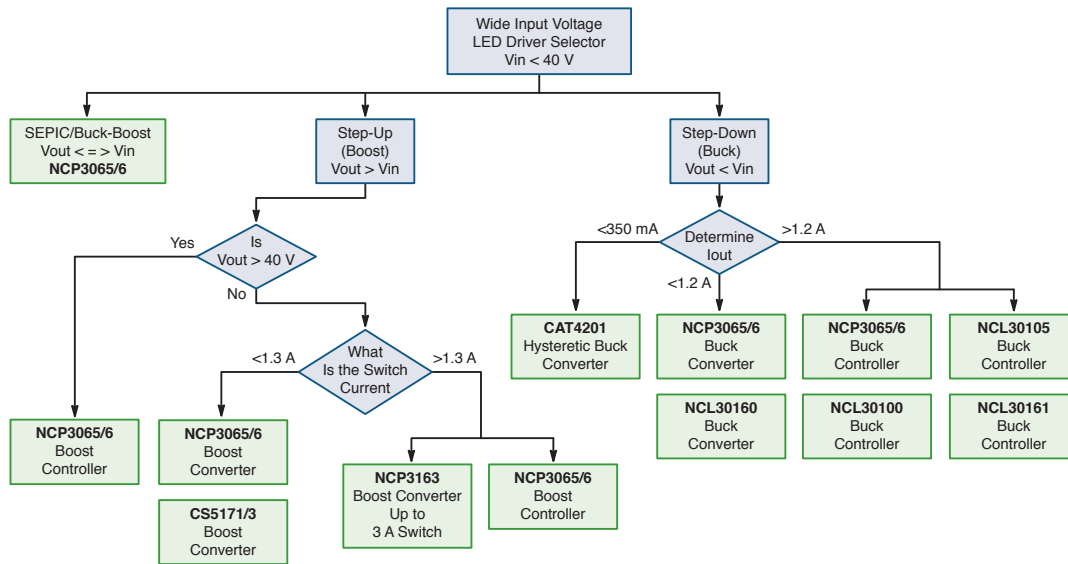

Device	Switching Frequency Typ (kHz)	Topology	Vin Range (V)	Switch Current (A) <sup>1</sup>	Controller	Automotive Qualified Device	Packages	Resources		
								Application	Evaluation Board	Documentation
NCP3065	Up to 200	Buck, Boost, Buck/Boost	3 to 40	1.5	**	NCV3065	SOIC-8, DFN-8, PDIP-8	Buck 3 A	NCP30653ABCKGEV	Application Note: AND8298/D
								Buck-Boost 350 mA, 550 mA MR16 LED bulb	NCP3065BBGEVB	Reference Design: TND373/D Design Note: DN06048/D
								SEPIC 350 mA, 700 mA, 1 A MR16 LED bulb	NCP3065D1SLDGEVB	Design Note: DN06033/D
								SEPIC 350 mA & 700 mA	NCP3065D2SLDGEVB	Design Note: DN06031/D
								SEPIC 700 mA	NCP3065D3SLDGEVB	Design Note: DN06031/D
								Buck with external P-channel MOSFET	NCP3065SOBCKGEVB	Application Note: AND8298/D
								Boost 1.5 A	NCP3065SOBSTGEVB	Application Note: AND8298/D
NCP3066	250	Buck, Boost, Buck/Boost	3 to 40	1.5	**	NCV3066	SOIC-8, DFN-8, PDIP-8	SEPIC 350 mA, 700 mA, 1 A	NCP3066DFSEPGEVB	Application Note: AND8298/D
								Buck 3A	NCP3066S3BCKGEVB	Application Note: AND8298/D
								Boost <1 A	NCP3066SCBSTGEVB	Application Note: AND8298/D
NCP3163	Up to 200	Buck, Boost, Buck/Boost	2.5 to 40	3.4		NCV3163	SOIC-16W, DFN-18	Boost 700 mA	NCP3163BSTEVB	
								Buck 3A	NCP3163BUCKGEVB	
								Inverter 500 mA	NCP3163INVGEVB	
MC33163	Up to 50	Buck, Boost, Buck/Boost	2.5 to 40	3.4			SOIC-16			
CAT4201	50 - 1000	Buck	7 to 36	0.7		CAV4201	TSOT-23-5	Buck 300 mA	CAT4201AGEVB	Design Note: DN06067/D
NCP1034	Up to 500	Buck	8 to 100	-	✓		SOIC-16	Buck 5 A, 5 Vout	NCP1034BCK5VGEVB	Design Note: DN06041/D Design Note: DN06047/D
CS5171/3	280 / 560	Boost or SEPIC	2.7 to 30	1.5		NCV5171/3	SOIC-8	Boost 400 mA, 5 Vout	CS5171BSTGEVB	
NCP1294	1000	Buck, Boost, Buck/Boost	4.7 to 100	-	✓		TSSOP-16, SOIC-16	High Voltage LED Driver (24 Vin to 110 Vout @ 100 mA)		Design Note: DN06062/D
NCL30100	Up to 700	Buck	6.35 to 18	-	✓	-	TSOP-6	Buck 700 mA MR16 LED bulb	NCL30100ADLMGEVB	
								Buck 700 mA PWM dimmable LED driver	NCL30100ASLDGEVB	
NCL30105	Up to 500	Buck	Up to 22	-	✓		SOIC-8	High Voltage Input, 350 mA Buck LED Driver	NCL30105GEVB	
NCL30160	Up to 1.4 MHz	Buck	6.5 to 40	1			SOIC-8	Up to 40 V, 1 A Buck LED Driver	NCL30160GEVB	
NCL30161	Up to 2.4 MHz	Buck	6.3 to 40	-	✓		DFN-10			

<sup>1</sup> For switching regulators, this current is used to calculate LED current based on Vin conditions. \*\* Can be configured as a controller.



## LED MR16 Light Bulb

### NCL30100, Fixed Off-Time Step-Down LED Driver Controller

- Quasi-fixed OFF time, peak current hysteretic control method thus requiring no compensation components
- Low Side N-FET switch topology
- Intended for continuous conduction mode operation, thus no output capacitor is needed
- >500 kHz operation
- $\pm 5\%$  typical current regulation tolerance
- $V_{CC}$  operation from 6.35 to 18 V

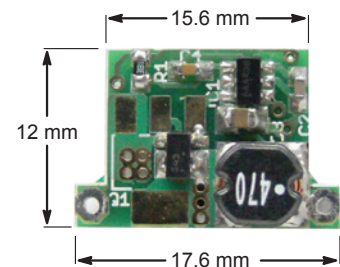
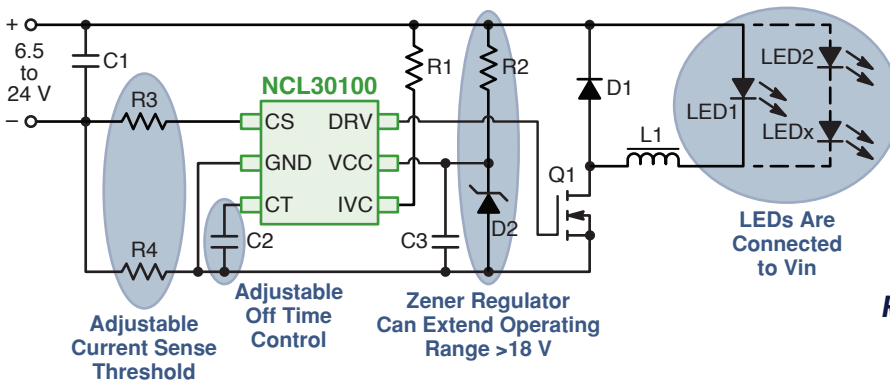

### Resources

- Evaluation Boards
  - NCL30100ADLMGEVB: MR16 form factor
  - NCL30100ASLDGEVB: PWM dimmable

MID-VOLTAGE  
GENERAL LIGHTING

## Solar-Powered LED Street Sign

### NCL30160 – Constant Current Step-Down LED Driver for High Power LEDs

- 30 m $\Omega$  integrated MOSFET
- 100% duty cycle for high efficiency
- Input voltage: 6.3 V to 40 V
- Switching frequency: Up to 1.4 MHz
- Dedicated PWM dimming pin/low power shutdown
- No control loop compensation required
- 1.5 A average current capability

### Resources

- Evaluation Board: NCL30160GEVB

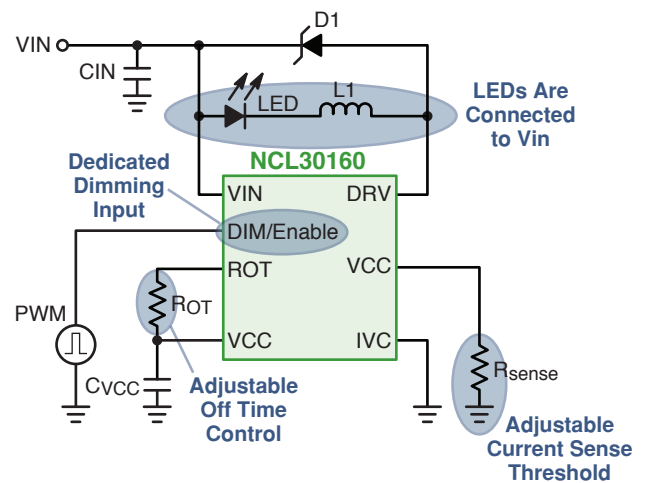
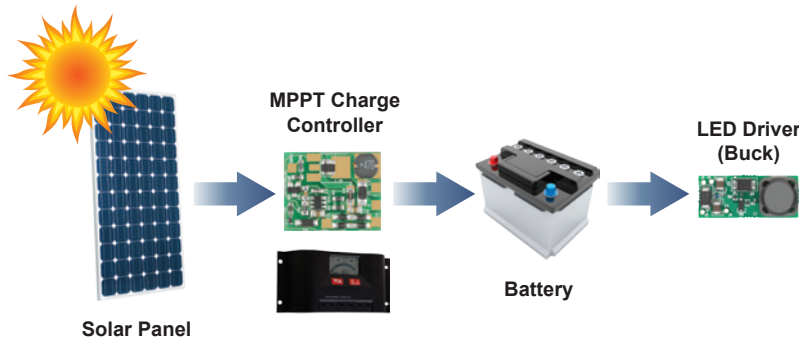

## 12 V AC-DC Design for 3 and 4 LED Modules

The circuit described in the DN06048/D Design Note is intended for driving multi-die LED modules like the Sharp mini-ZENIGATA™, 12 V Cree XLamp™ XT-E, and other LEDs in low voltage 12 Vac/Vdc applications. The forward voltage of the modules overlaps the input voltage range, so a single switch buck-boost configuration is used.

### Features

- Small size
- Wide input and output operation voltage
- Regulated output current
- Open LED protection
- Output short circuit protection

### Applications

- MR16 bulbs
- Landscape lighting
- Transportation lighting

### Resources

- Design Note DN06048/D
- Reference Design: TND373/D
- Evaluation board: NCP3065BBGEVB, buck-boost MR16

MID-VOLTAGE GENERAL LIGHTING



Sharp mini-ZENIGATA LED Module

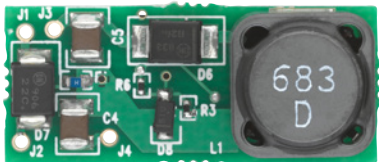
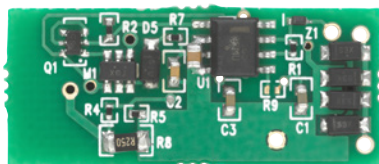

Reference Design Demo Board  
0.457" x 1.148" (11 mm x 29 mm)

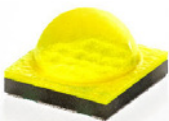

12 V Cree XLamp XT-E LED

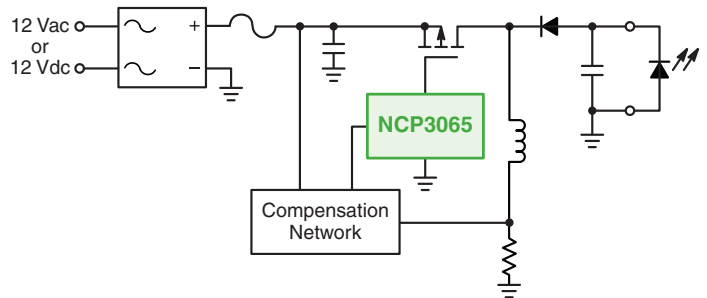

Reference Design Block Diagram

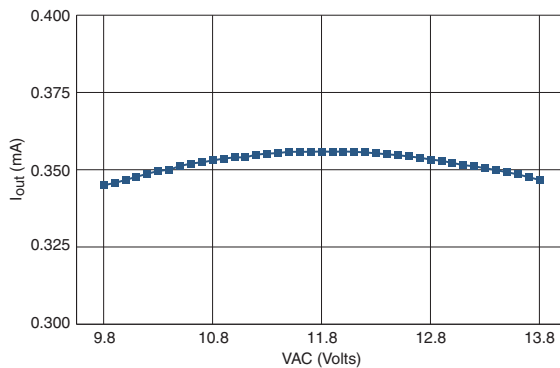

I<sub>out</sub> versus Vac Input



MR16 LED Module

# MID-VOLTAGE AUTOMOTIVE LIGHTING

## Automotive Lighting Systems



ON Semiconductor offers standard products and custom devices for automotive lighting applications. The company leads the market for Xenon driver ASICs and developed the defacto standard stepper driver for headlight leveling and swiveling.

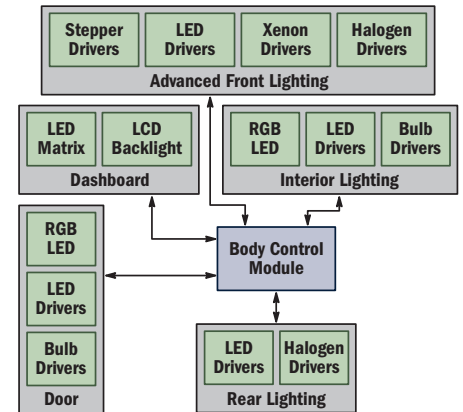

## Front Lighting

The majority of automobiles on the road today are equipped with halogen lights for the high-beam (HB) and low-beam (LB) functions - the main front lighting functions. Halogen LB typically consumes 55 W, and provides ~1,000 lumen. HID technology - introduced over ten years ago - consumes 35 W, and provides ~3,500 lumen. Because of the high intensity and risk of glare to approaching traffic, some countries require automatic leveling of the LB, plus a high pressure cleaning device. Over time, HID lights will integrate the HB function into bi-xenon solutions.

While halogen technology continues to be viable for front lighting, automotive designs increasingly use LED lighting. LED lighting offers enhanced styling options, enables 'instant-on' lighting, and allows brightness control from 0% to 100% power.

Another important aspect for automotive front lighting is beam swiveling for Advanced Frontlighting Systems (AFS), to optimize the

visibility in curves, and Adaptive Driving Beam (ADB), to adapt the beam to real-time situations. Stepper motors provide the primary controls for AFS and ADB.

ON Semiconductor offers a full range of products, from generic bulb driver solutions to stepper drivers, LED drivers, and Xenon drivers, that are specifically designed for front lighting.

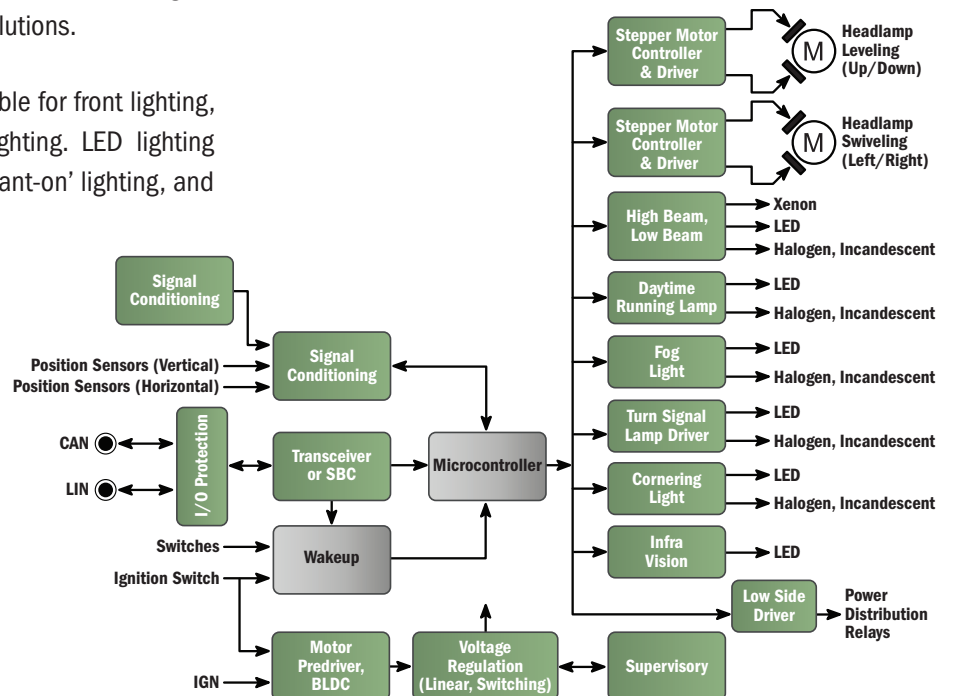

MID-VOLTAGE  
AUTOMOTIVE LIGHTING

## Leveling and Swiveling for Front Lighting

The AMIS-30623 single-chip micro-stepping motor driver, with integrated controller and LIN interface, enables the design of dedicated mechatronic solutions connected remotely with a LIN master. The device receives positioning

instructions through the bus and subsequently drives the motor coils to the desired position, using configurable parameters for current, speed, acceleration, and deceleration. AMIS-30623 also detects motor stalling.

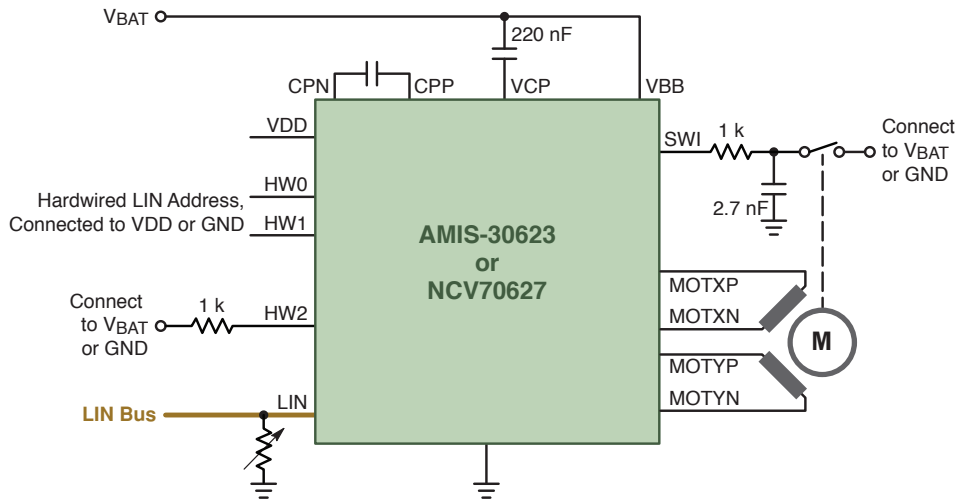

NCV70521 and NCV70522 are single-chip micro-stepping motor drivers with current translation table and SPI interface. NCV70522 also includes an embedded 5 V regulator and a watchdog reset. The devices act as peripheral drivers, receiving 'Next Micro-Step'

commands from a microcontroller, and synchronizing the motor coil-current with the desired speed. The integrated SPI bus allows parameter setting and diagnostics feedback.

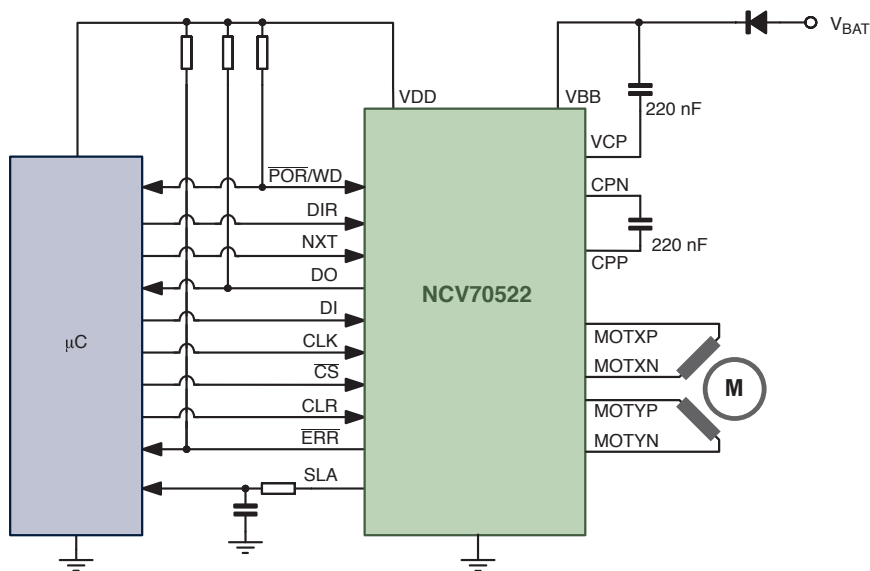

## Power Ballast and Dual LED Driver for Advanced LED Front Lighting Systems

The NCV78663 single-chip, intelligent LED driver for front lighting enables single-module control of high beams, low beams, daytime running lights, position lights, cornering lights, turn indicators, and fog lights. With integrated digital dimming, SPI

programmable settings, and build-in diagnostics, the NCV78663 offers an integrated, energy efficient solution for comprehensive front lighting control.

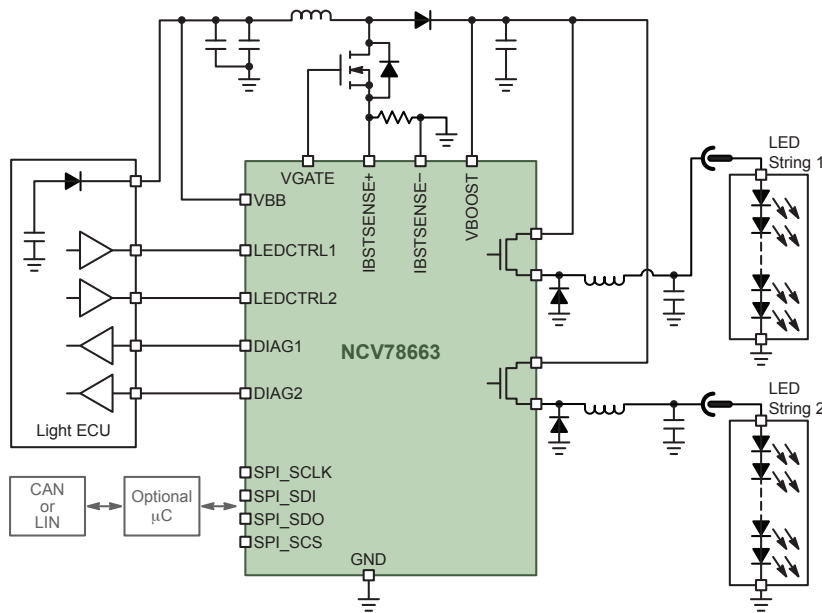

### Features - NCV78663

- System integrated solution with few external components.
- Buck-boost topology
- LED current regulator
  - Constant average current
  - Efficient integrated buck switches (high-side)
  - Current up to 2 A
- Extended diagnostics: detection of open circuit or failing driver, short, over-current protection, single LED failures
- Thermal protection
- System customization by SPI interface and/or OTP-settings
  - Multiple system configurations with one device
  - Fewer module versions for OEM
- Better EMC behavior, without extra filtering
  - Low EMC from battery
  - Low EMC to LED string
- High overall efficiency (>90%)

MID-VOLTAGE  
AUTOMOTIVE LIGHTING



NCV78663 Demonstration Kit

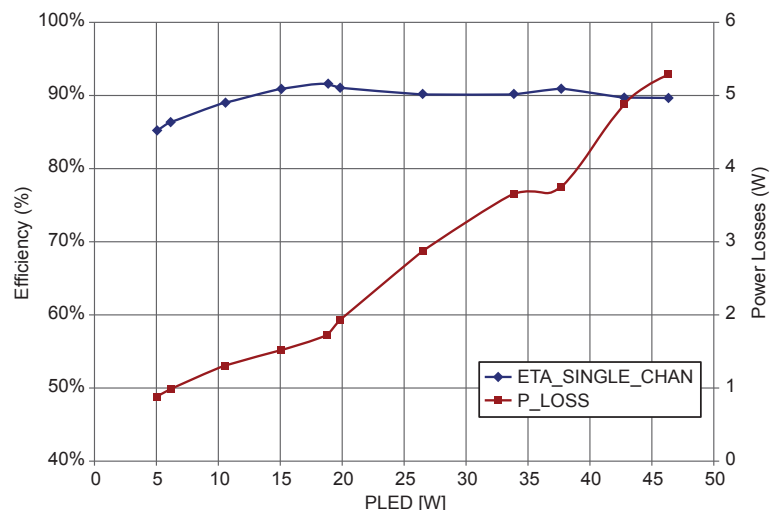

NCV78663 Demonstration Board Efficiency

## Linear Current Regulator and Controller for Automotive LED Rear Combination Lamps

### Features - NCV7680

- Constant current outputs for LED string drive
- Open LED string diagnostic with open-drain output
- Slew rate control eliminates EMI concerns
- On-chip 1 kHz tail PWM dimming
- Over-voltage and over-temperature set back power limitation



Automotive battery systems have wide variations in line supply voltage. Low dropout is a key attribute for providing consistent LED light output at low line voltage.

The NCV7680 consists of eight linear programmable constant current sources. System design with the NCV7680 allows for two brightness levels, one for stop and one for tail illumination. Optional PWM control - the preferred method for dimming LEDs - can also be implemented. The PWM generator's fixed frequency provides flicker-free illumination. Optional external ballast FET allows for power distribution on designs requiring high currents.

To support the common RCL configuration of LED strings, the NCV7680 provides eight matched outputs for individual string drive, with current set by a single resistor. Individual string drive ensures equal current distribution between the strings.

The NCV7680 can function as a standalone device or in conjunction with additional support circuitry for more complex systems. When operating in combination with a boost controller, additional LEDs may be connected to a string.

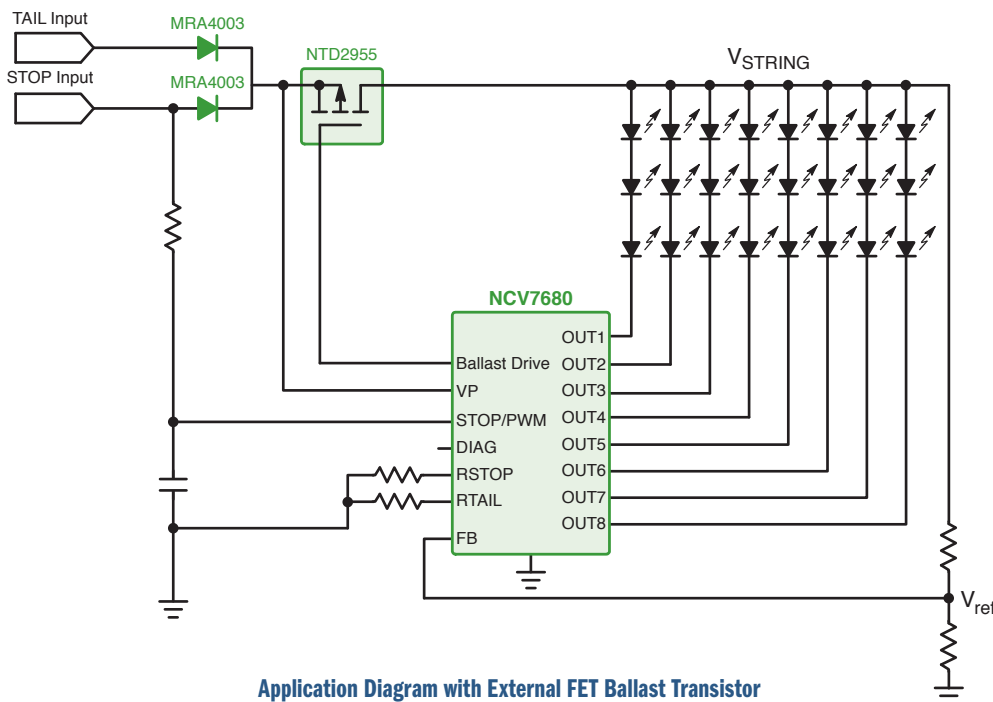

Application Diagram with External FET Ballast Transistor

## Automotive LIN RGB LED Driver for Interior Lighting

The LIN Bus (Local Interconnect Network) is an inexpensive serial communications protocol, which is used within current automotive network architectures. It is a relatively slow communication system intended to monitor sensor devices or actuators in today's cars.

The NCV7430, LIN RGB LED Driver, combines a LIN transceiver together with a RGB LED driver and memory. It is a single-chip RGB driver intended to monitor for dedicated multicolor LED applications in automotive interior lighting. It contains a LIN interface (slave) for parametric programming of LED color and

intensity. The device receives instructions through the LIN bus and subsequently drives the LEDs independently.

The NCV7430 acts as a slave on the LIN bus and the master can request specific status information (parameter values and error flags). The LIN address of the NCV7430 can be programmed in the internal memory of the device.

The NCV7430 is fully compatible with automotive requirements.

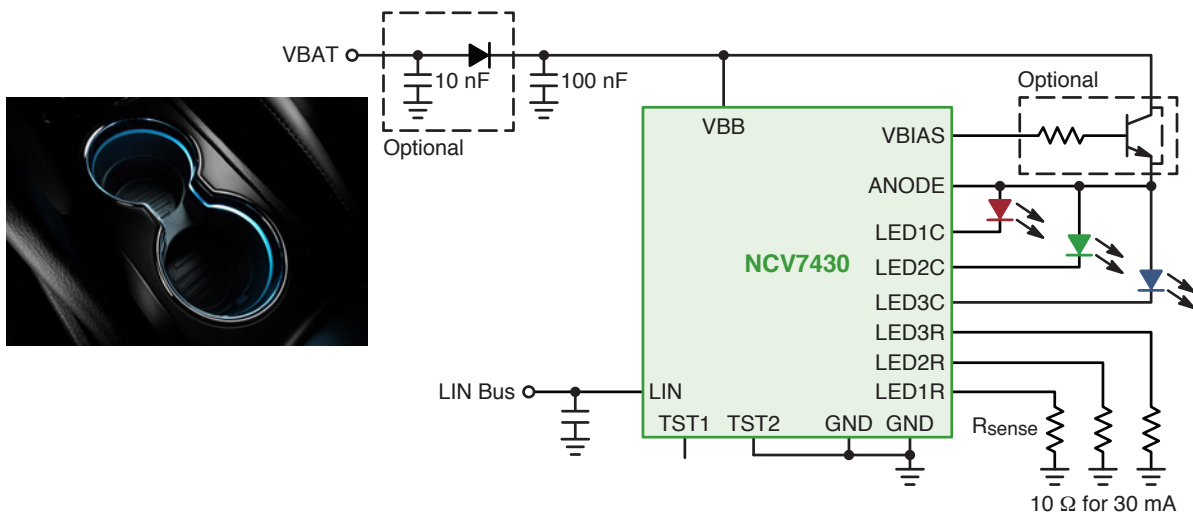

### Features – NCV7430

#### RGB LED Driver

- 3 independent LED current regulators
- LED currents programmable with external resistors
- Power dissipation option with external ballast transistor
- LED temperature compensation with external sense circuit
- Modulation control for 3 LEDs (with calibration)

#### LIN Interface

- LIN physical layer according to LIN 2.1/SAE J2602
- OTP-programmable device node number and group address
- Diagnostics and status information about LEDs

#### Protection and Diagnostics Over-Current Detection

- Short circuit detection to GND and VBB
- Open LED detection
- High temperature warning and shutdown
- Retry mode on error detection

#### Power Saving

- Sleep mode supply current 20  $\mu$ A
- Compliant with 14 V automotive systems

#### EMI Compatibility

- LIN Bus integrated slope control
- EMC reduced LED modulation mode

## Constant Current Regulators for Automotive Exterior and Interior Lighting

The two-terminal linear constant current regulators (CCRs) are simple, economical, and robust devices that provide an effective solution for regulating current in cost-sensitive LED applications. The devices require no external components, allowing them to be implemented as high or low-side regulators. These

devices regulate output current over a wide range of input voltage, and are designed with a negative temperature coefficient to protect LEDs from thermal runaway at extreme voltage and operating temperature.

### Features

- Regulated current provides constant brightness over wide voltage range
- Negative temperature coefficient protects LEDs in high ambient conditions
- Available with multiple maximum operating voltages (45 V, 50 V, and 120 V) to withstand battery load dump

### Resources

- Sample Kit: CCR2KIT/S

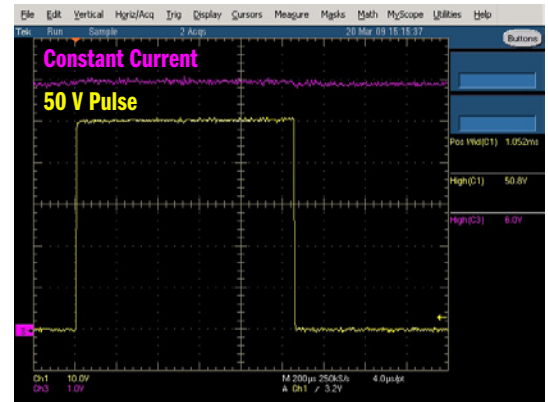
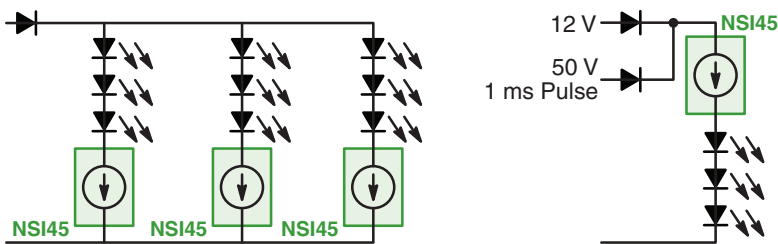

### Applications

- Exterior Lighting – CHMSL (Center High Mounted Stop Lighting)
- Interior Lighting – Dome light, vanity mirror light, glove box

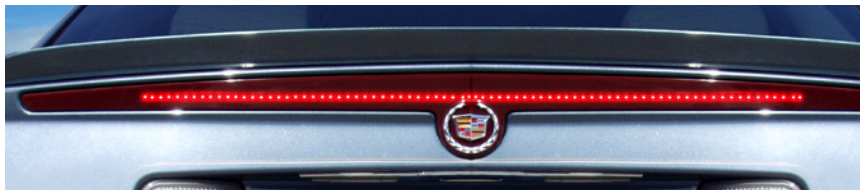

Device	Max Anode-to-Cathode Voltage ( $V_{AK}$ ) (V)	Voltage Overhead ( $V_{in} - V_{LEDs}$ ) (V)	Constant Current $I_{reg}$ (@ $V_{ak} = 7.5 V$ ) (mA)	Current Tolerance Over Voltage	Max Junction Temperature ( $^{\circ}C$ )	Packages
NSI45xxx	45	1.8	Fixed: 15, 20, 25, 30	$\pm 15\%$ , $\pm 10\%$	150	SOD-123, SOT-223
NSI50xxx	50	1.8	Fixed: 10, 350	$\pm 10\%$	175	SMC, DPAK
NSIC20xx	120	1.8	Fixed: 20, 30, 50	$\pm 15\%$	175	SMB
NSI45xxxJ	45	1.8	Adjustable: 20 to 40, 35 to 70, 60 to 100, 90 to 160	$\pm 15\%$	150	SOT-223, DPAK
NSI50150AD	50	1.8	150 to 350	$\pm 10\%$	175	DPAK

NOTE: xxx in the device number represents the current level.





# AC-DC

## AC Line Powered LED Driver Topologies

There are numerous topologies for driving LEDs off the AC mains, depending on the requirements of the application (size, efficiency, power factor, power delivered, drive current). Fortunately,

ON Semiconductor provides a wide range of power solutions, whether the application is a 5 W LED under-cabinet light or a 150 W LED streetlight.

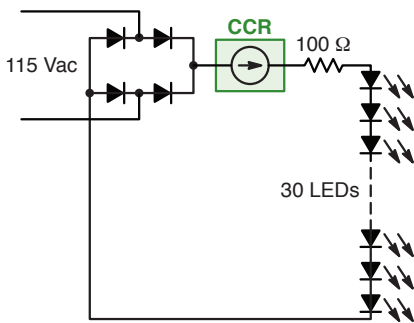

Non-Isolated Linear Driver

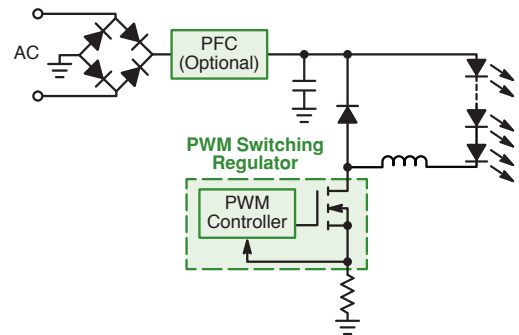

Non-Isolated Buck Driver

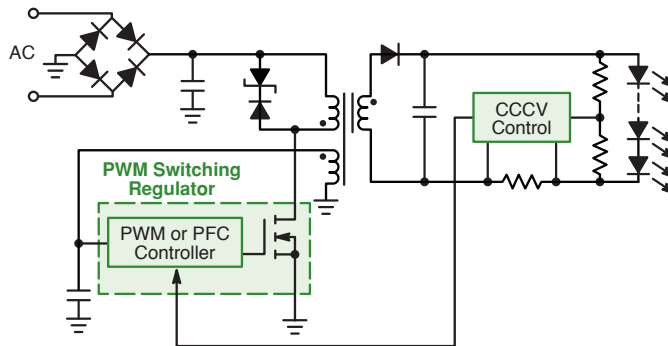

Single-Stage Flyback LED Driver

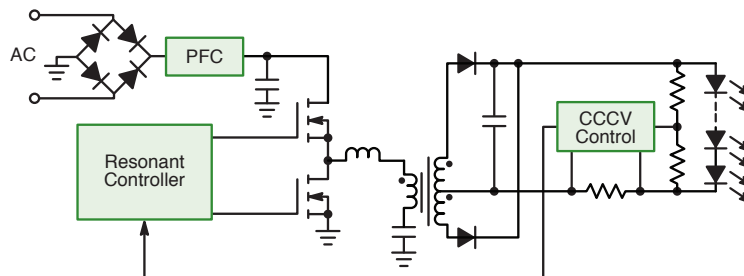

Dual-Stage Power Factor Corrected Isolated LED Driver

AC-DC

## Power Factor Correction – NCP1611/2

### 160 W PFC Boost Using NCP1611 or NCP1612

- Improved efficiency in light load over traditional CrM PFC
- Unlike CrM, switching frequency is reduced at light load
- Improved reliability and safety without extra components

#### Features

- CrM with Current Controlled Frequency Foldback (CCFF)
- Shorted Boost or Bypass Diode Protection
- Comprehensive Open / Short Pin Protection
- Enhanced Transient Response
- Low THD Configuration
- Soft Overvoltage Protection
- Thermal Shutdown
- Brownout Detection
- Wide Vcc Range to 35 Vdc

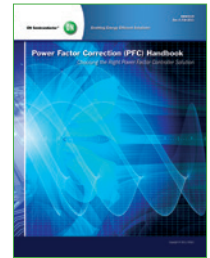
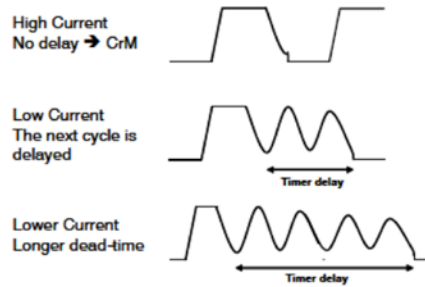

HBD853/D Available at [www.onsemi.com](http://www.onsemi.com)

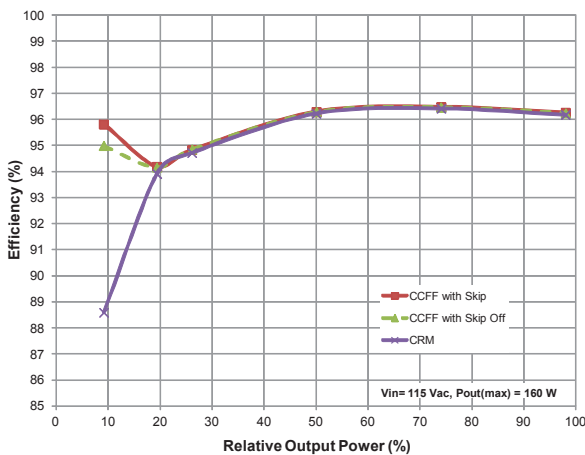

Efficiency vs Power @ 115 Vac

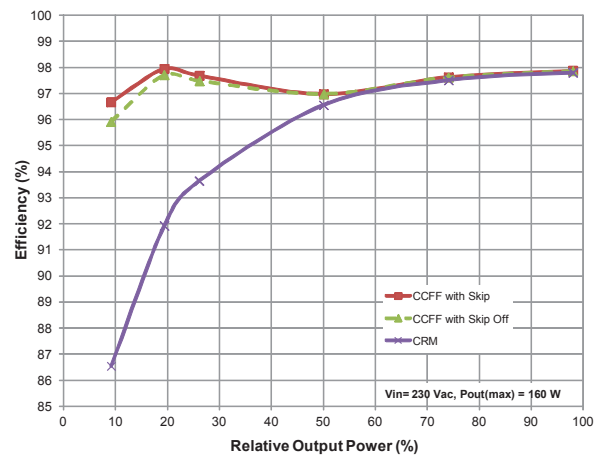

Efficiency vs Power @ 230 Vac

Device	Topology	Conduction Mode	Control	HV Start-up	Overvoltage Protection	Undervoltage Protection	Current Limit	Power Limit	Brown Out	In-Rush Detect	Package(s)	Notes
NCP1607	Non-Isolated Boost	Critical	Voltage		✓	✓	✓				SOIC-8	Enhanced fault protection
NCP1608	Non-Isolated Boost	Critical	Voltage		✓	✓	✓				SOIC-8, PDIP-8	Wide dynamic power range
NCP1611/12	Non-Isolated Boost	CCFF**	Current		✓	✓	✓		✓	✓	SOIC-8, SOIC-10	CCFF** control scheme provides energy savings and low THD across load
NCP1615	Non-Isolated Boost	CCFF**	Current	✓	✓	✓	✓		✓	✓	SOIC-14, SOIC-16	Latched and autorecovery versions
NCP1654	Non-Isolated Boost	Continuous	Average Current		✓	✓	✓	✓	✓	✓	SOIC-8, PDIP-8	65/133/200 kHz versions
NCL30000	Isolated Single-Stage Flyback, Non-Isolated Buck	Critical	Average Current		✓	✓	✓				SOIC-8	TRIAC dimming compliant
NCL30001	Isolated Single-Stage Flyback	Continuous	Average Current	✓		✓	✓	✓	✓		SOIC-16	–
NCL30002	Non-Isolated Buck	Critical	Constant on-time, Peak current		✓	✓	✓				SOIC-8	TRIAC dimming compliant
NCL30060*	Single-Stage Flyback or Buck	Critical	Voltage	✓	✓	✓	✓		✓		SOIC-7	Latched and autorecovery versions; with and without brownout

\* Pending 2Q14. \*\*CCFF: Current Controlled Frequency Foldback. Note: All devices have a temperature range of -40 to +125 °C.

## Primary Side Control Offline LED Drivers

### Features

- Opto-coupler free
- Precise LED current regulation of  $\pm 1\%$  (typ)
- Supports flyback and buck-boost topologies
- Wide  $V_{CC}$  range
- High efficiency quasi-resonant control
- $\sim 0.9$  power factor with passive PFC input
- Robust protection suite
- Scaleable family
- User programmable thermal foldback
- Analog/Digital and step dimming versions
- Broad temperature range of  $-40$  to  $+125$  °C

### Applications

- Replacement LED Bulbs
- Offline LED Drivers
- Downlights
- Indoor/Outdoor Accent and Task Lighting
- Electronic Control Gear for LEDs

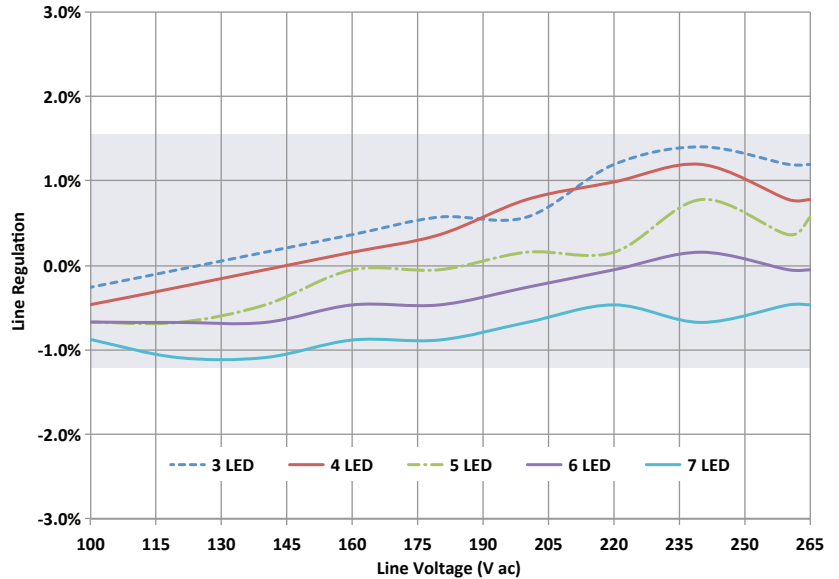

Evaluation Boards and Design Tools Available

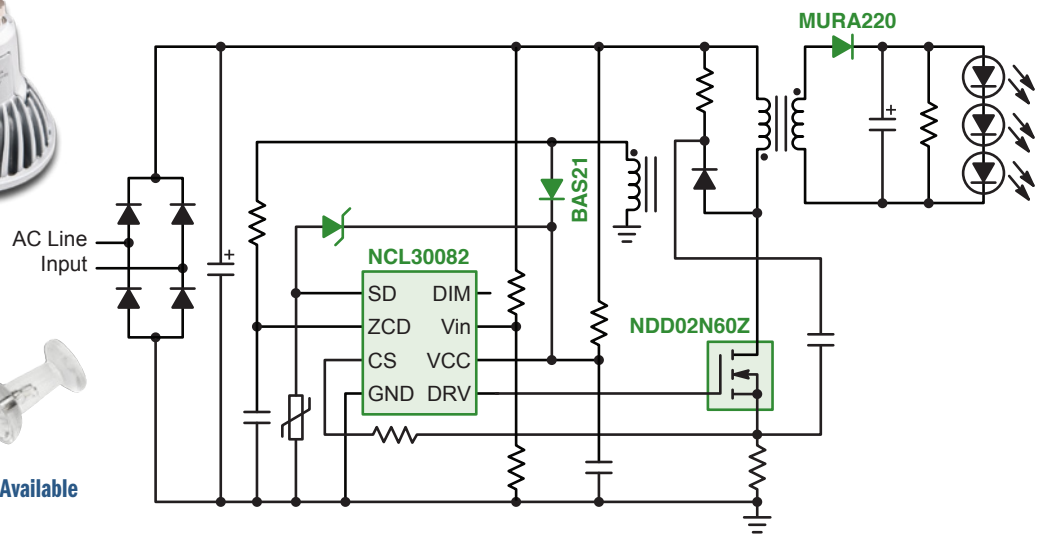

Device	Power Factor Control	Dimming Control	Thermal Foldback	Adjustable Overvoltage Protection	Package
NCL30080A/B	Passive	Non-Dimming	No	No	TSOP-6
NCL30081A/B	Passive	5 Step	No	No	TSOP-6
NCL30082A/B	Passive	Analog/Digital	Yes	Yes	Micro8™/SOIC-8
NCL30083A/B	Passive	5 Step	Yes	Yes	Micro8
NCL30085A/B*	Active	3 Step	Yes	Yes	SOIC-8
NCL30086A/B*	Active	Analog/Digital	Yes	Yes	SOIC-10
NCL30087A/B*	Active	TRIAC/Trailing Edge	Yes	Yes	SOIC-10
NCL30088A/B*	Active	Non-Dimming	Yes	Yes	SOIC-8

\* Pending 2H14.

AC-DC

## Switching Regulators for AC-DC

### Switching Regulators for Isolated Flyback and Non-Isolated Converters

Device	Max Output Power <sup>1</sup> (W)	Mode	Power Switch Voltage (Vdc)	Peak Current Limit (mA)	Typ <sup>2</sup> RDS(on) (Ω)	Min HV Startup (Vdc)	Frequency Options (kHz)	Dynamic Self Supply	Freq Jittering	Latch	Brownout	Soft-Start	Freq Foldback	Over Power Compensation	Package(s)
NCP1010	4	Current	700	100	22	30	65, 100, 130	✓	✓			✓			PDIP-7, SOT-223
NCP1011	11	Current	700	250	22	30	65, 100, 130	✓	✓			✓			PDIP-7, SOT-223
NCP1012	11	Current	700	250	11	30	65, 100, 130	✓	✓			✓			PDIP-7, SOT-223
NCP1013	15	Current	700	350	11	30	65, 100, 130	✓	✓			✓			PDIP-7, SOT-223
NCP1014/15 <sup>3</sup>	17	Current	700	450	11	30	65, 100	✓	✓			✓			PDIP-7, SOT-223
NCP1027/28 <sup>3</sup>	20	Current	700	800	5.6	30	65, 100		✓	✓	✓	✓	✓		PDIP-7
NCP1072/5	14	Current	700	250/450	11	90	65, 100, 130	✓	✓			✓	✓		PDIP-7, SOT-223
NCP1076/7*	22	Current	700	650/800	4	90	65, 100, 130	✓	✓			✓	✓		PDIP-7, SOT-223

\* Pending 2Q14. 1. Maximum Power Output with DSS 2. Typical at 25°C 3. NCP1015 & NCP1028 have no OVP on VCC

### High Power Factor Boost for HV LED Strings – NCP1075 & NCP4328A

High voltage multi-junction LEDs are becoming more common as suppliers move to better optimize the LED for better overall system efficacy and introduce more application specific LEDs. The LEDs can have a nominal forward voltage per package ranging from 24-200 V, and may be optimized for spot, omni-directional, or linear lighting. The boost circuit described in DN05055/D provides constant current and high power factor to a string of LEDs. To achieve this with low parts count and a standard off-

the-shelf inductor, an NCP1075 monolithic HV switcher is used with the highly accurate NCP4328A Constant Current/Constant Voltage controller.



#### Features

- > 90% efficiency
- Fast 20 ms startup
- Open LED protection
- Off-the-shelf inductor
- > 0.95 power factor
- > 10 W power capability with NCP1075

#### Applications

- LED bulbs and tube lights
- Low power luminaires and fixtures
- Electronic control gear
- LED drivers

#### Resources

- 90-135 or 200-265 Vac reference designs
- Design Note: DN05055/D

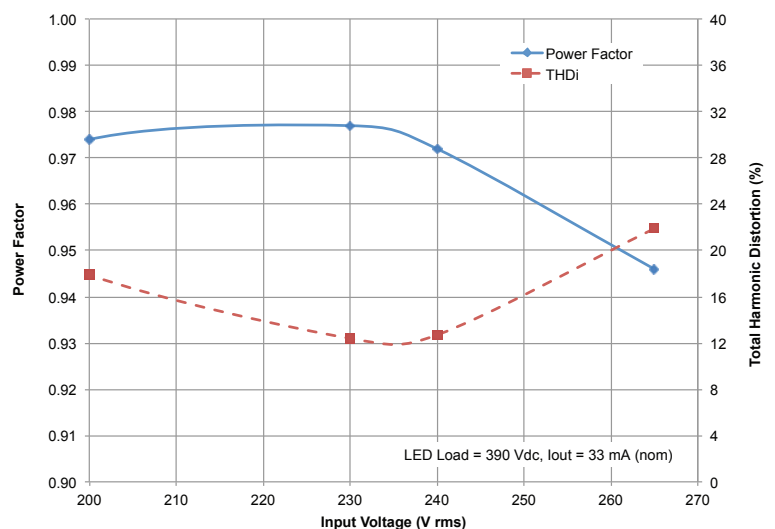

## Switching Controllers for AC-DC

### Switching Controllers versus Switching Regulators

- Controllers are typically used for power levels > 25 W
  - Controllers offer more flexibility in selecting the high voltage MOSFET that is most suitable for a given application and power output
  - Can be used in isolated flyback converters and non-isolated converters

### Switching Controllers for Isolated and Non-Isolated Buck, Buck/Boost Converters

PWM Method	Device	Control Mode	Switching Frequency (kHz)	Frequency Jittering (%)	HV Startup	Dynamic Self Supply	Short Circuit Protection	Brown-Out Protection	Over Voltage Protection	Soft Start (ms)	Drive Capability Source/Sink (mA)	Temperature (°C)	Package(s)	Comments
Fixed Frequency	NCP1200	Current	40, 60, 100	±0.7	✓	✓	✓ <sup>1</sup>				250 / 250	-25 to +125	SOIC-8, PDIP-8	–
	NCP1203	Current	40, 60, 100		✓						250	-40 to +125	SOIC-8, PDIP-8	–
	NCP1218 NCP1219	Current	65, 100	±11 ±7.5	✓	✓	✓ <sup>1</sup>			4.8	500 / 800	-40 to +125	SOIC-7	• Adjustable Max duty cycle • ±5% current sense accuracy
	NCP1230	Current	100	±6.4	✓		✓		✓	2.5	500 / 800	-40 to +125	SOIC-8, PDIP-7	–
	NCP1234/6	Current	65, 100	±6	✓	✓	✓	✓	✓	4	500 / 500	-40 to +125	SOIC-7	• Timer-based short circuit protection • OVP and OVT compensation
	NCP1237/8	Current	65, 100, 130	±6	✓	✓	✓	✓	✓	4	1000 / 1000	-40 to +125	SOIC-7	• Timer-based short circuit protection • OVP and OVT compensation
	NCP1250/1/3	Current	65, 100	±6			✓	✓	✓	4	300 / 500	-40 to +125	TSOP-6	• Timer-based short circuit protection
PWM Method	Device	Control Mode	Frequency Clamp Max ON Time (µs)	Frequency Clamp Min OFF Time (µs)	HV Startup	Dynamic Self Supply	Short Circuit Protection	Brown-Out Protection	Over Voltage Protection	Soft Start (ms)	Drive Capability Source/Sink (mA)	Temperature (°C)	Package(s)	Comments
Quasi-Resonant	NCP1207A	Current	NO	8	✓	✓	✓		✓	1	500 / 500	-40 to +125	SOIC-8, PDIP-8	–
	NCP1308	Current	NO	10	✓	✓	✓		✓	1	500 / 500	0 to +125	SOIC-8	–
	NCP1337/38	Current	67	35	✓	✓	✓	✓	✓	4	500 / 500	0 to +125	SOIC-8, PDIP-8	Brown out protection
	NCP1377	Current	NO	3, 8	✓				✓	1	500 / 500	-40 to +125	SOIC-8, PDIP-8	–
	NCP1379/80	Current	NO	5.9	✓			✓	✓	3.8	500 / 800	0 to +125	SOIC-8	OVP and OVT protection
	NCP1336	Current	NO	5.25	✓		✓	✓	✓	5.0	500 / 800	-40 to +125	SOIC-14	Valley lockout; OPP

1. When DSS is used.

### Switching Controllers for Non-Isolated Buck Converters

Device	Vin (Vac)	Max Output Power (W)	TRIAC Dimming	PWM Dimming	Analog Dimming	Package(s)
LV5011MD	85 to 305	6	✓		✓	SOIC-10
LV5012MD	85 to 305	40	✓	✓	✓	MFP-14S
LV5026MC	85 to 305	30	✓	✓	✓	SOIC-10
LV5029MD	85 to 305	30		✓	✓	SOIC-10
NCL30002	20 to 305	50	✓			SOIC-8
NCL30105	Adj; HV DC	50		✓	✓	SOIC-8

## Switching Controllers for AC-DC (continued)

### Switching Controllers for Resonant Half-Bridge Converters

PWM Method	Device	Control Mode	Switching Frequency (kHz)	HV Startup	Short Circuit Protection	Brown-Out Protection	Over Voltage Protection	Soft Start	Thermal Shutdown	Temperature (°C)	Package(s)	Comments
Resonant Half Bridge	NCP1392/3	Voltage	Adjustable to 250	✓	✓	✓	✓	✓	✓	-40 to +125	SOIC-8	Fixed dead time options, PFC okay, 100 ms startup timer
	NCP1398	Voltage	Adjustable to 750	✓	✓	✓	✓	✓	✓	-40 to +125	SOIC-16	Enhanced soft start, dual level current protection

### Switching Combination Controllers

Device	Topology	Function	Vin (Vac)	Max Output Power (W)	Comments
NCL30051	Isolated Resonant Half-Bridge Converter	CRM PFC + half-bridge converter	85 to 305	60 to 250	Half-bridge stage with 600 V high side gate drive
NCL30030*	Medium/High Power Two-Stage	Enhanced CRM PFC + QR flyback	30 to 305	50 to 200	Multiplier input for low THD, high voltage startup

\*Pending 2014

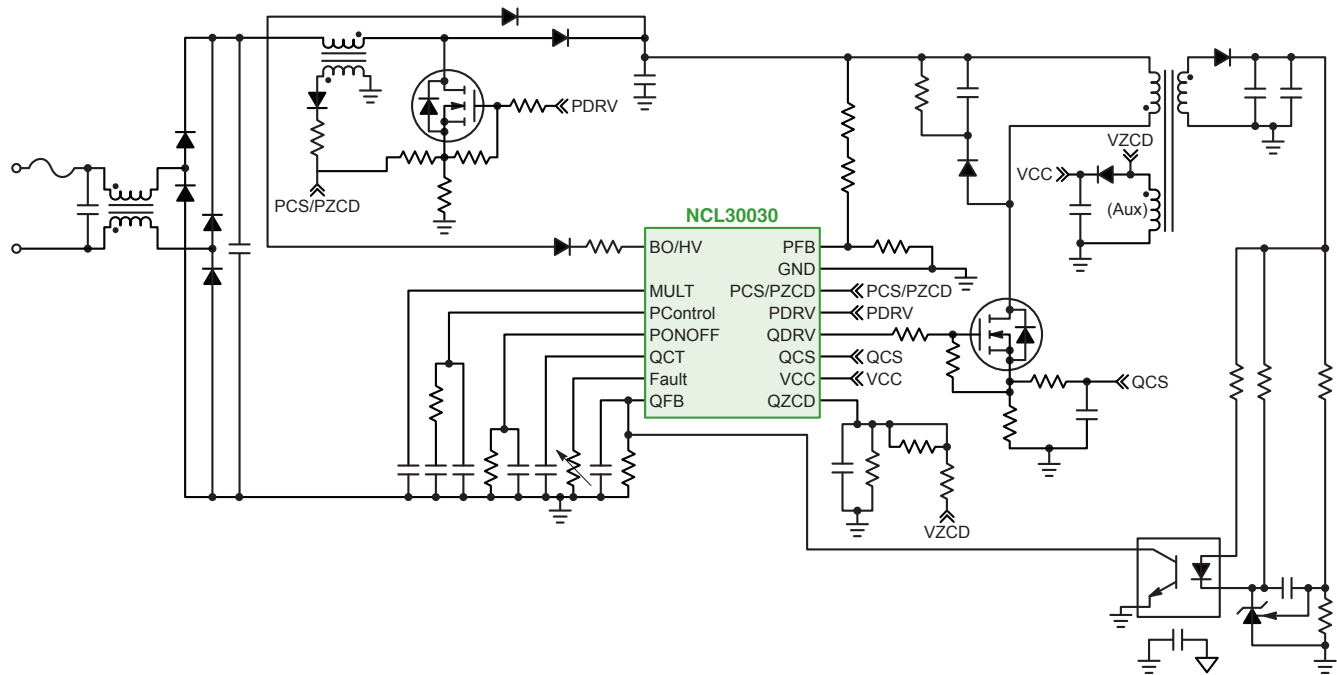

AC-DC

### Constant Current, Constant Voltage Secondary Side Controllers

Device	V <sub>(BR)</sub> Typ (V)	Tolerance (%)	I <sub>Q</sub> Typ (mA)	Temperature (°C)	V <sub>CC</sub> Max (V)	Package	Notes
NCP4300A	2.6	1	–	0 to 105	36	SOIC-8	–
NCS1002	2.5	0.4	0.4	-40 to 125	36	SOIC-8	–
NCP4328A	1.25	0.5	0.1	-40 to 125	36	TSOP-5	62.5 mV current sense level ±2% typical

#### Resources

- Application Note AND8395/D

## Offline Buck LED Driver – NCL30002

### Features

- Supports high PF or low ripple buck topologies
- High efficiency CRM control method
- 485 mV peak current sense of  $\pm 2\%$  (typical)
- Low typical 24  $\mu\text{A}$  startup current
- Maximum Vcc of 20 Vdc
- 500 mA source/800 mA sink MOSFET gate driver
- Wide -40 to +125 °C temperature range

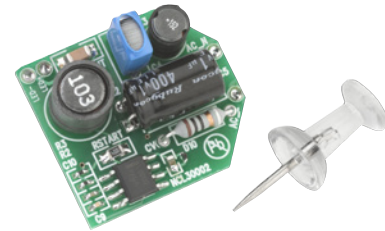

### Design Note Highlights

- Low ripple implementation
- Optimized for HV LEDs
- Uses off-the-shelf inductor
- Low bill-of-material count

### Applications

- Replacement LED bulbs including small candle style
- Downlights
- Indoor/outdoor accent and task lighting

Design Note	V <sub>in</sub> (Vac)	LED V <sub>f</sub> (Vdc)	I <sub>out</sub> (mA)	Efficiency
DN05041	85 - 115	60	60	87%
DN05042	200 - 265	150	25	85%

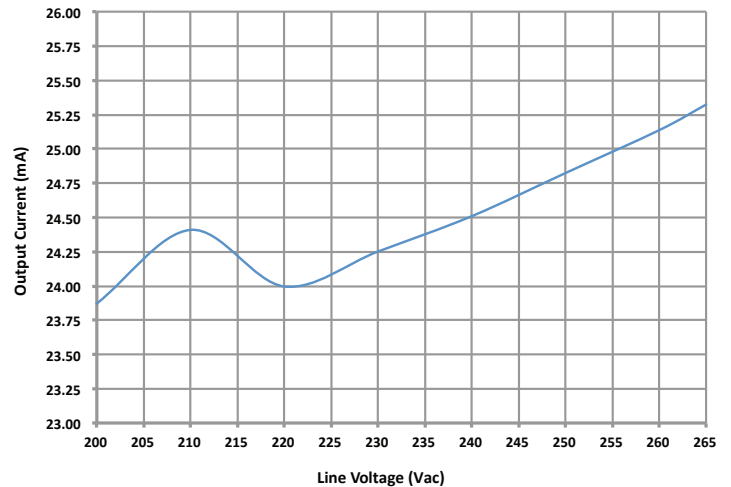

## Non-Isolated Offline Buck Controller – LV5026MC

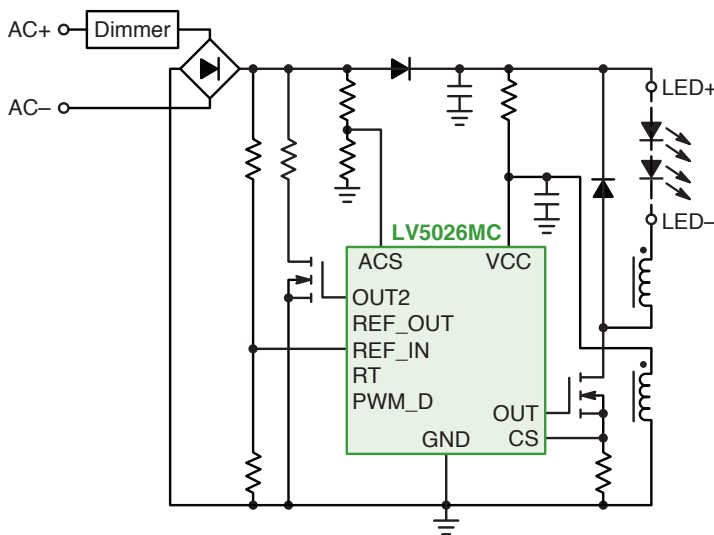

### Features

- Various dimming control (TRIAC, analog & PWM)
- Selectable switching frequency (50 kHz or 70 kHz)
- Low noise switching system
- Short-circuit protection
- Soft start function
- Built-in TRIAC stabilization function

### Applications

- Wall sconces
- Task lighting
- Step lighting
- LED bulb replacements



## Dimmable LED Drivers - LV50xx

Device	Topology	Conduction Mode	Switching Frequency (kHz)	Max Output Power (W)	Power MOSFET	Bleeder MOS	TRIAC Dimming	PWM Dimming	Analog Dimming	Improved Power Factor	Package	Notes
LV5026MC	Isolated Single-Stage Flyback, Non-Isolated Buck, Non-Isolated Buck-Boost	Discontinuous	50 or 70	40	External	External	✓	✓	✓	✓	SOIC-10	• Simple application
LV5029MD		Discontinuous	50 or 70	40	External	-			✓	✓	SOIC-10	• Simple application
LV5011MD		Discontinuous	70	6	Internal	External	✓	✓	✓	✓	SOIC-10	• Small size solution
LV5012MD		Discontinuous	70	40	External	Internal	✓	✓	✓	✓	MFP-14S	• High power factor and good line regulation • Built-in HV Startup MOS

### Features - LV5011MD

- Dimming control driver (TRIAC & Analog)
- Switching frequency 70 kHz
- Built-in POWER MOSFET (power limited 6 W)
- Built-in TRIAC stabilized function (internal circuit)
- Improved power factor
- Externally-adjustable reference voltage
- Over voltage protection
- Thermal shutdown
- Topology: Fly-back (isolated), Buck and Buck-Boost (non-isolated)

### Applications

- Small dimmable LED bulbs, such as GU10
- Offline LED drivers
- Down lights

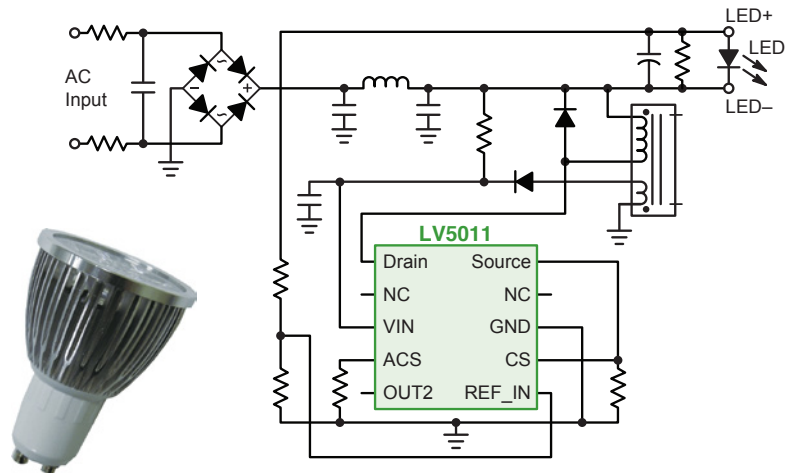

AC-DC

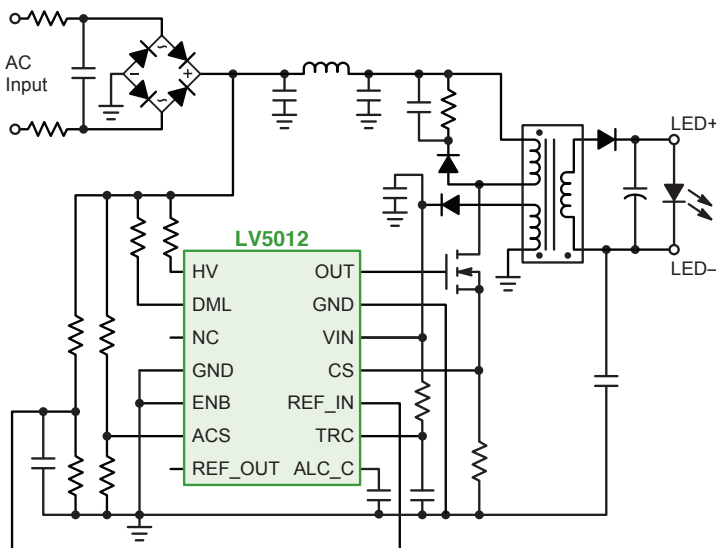

### Features - LV5012MD

- Various dimming controls (TRIAC, Analog, PWM)
- Switching frequency 70 kHz
- Built-in start-up MOSFET
- Built-in TRIAC stabilized function (internal MOSFET)
- Improved power factor
- Externally-adjustable reference voltage
- Over voltage protection
- Thermal shutdown
- Topology: Fly-back (isolated), Buck-Boost (non-isolated)

### Applications

- Dimmable LED bulbs
- Offline LED drivers
- Down lights



## Non Isolated Linear LED Driver Topology – Constant Current Regulators (CCRs)

### Low Current LED String Driver

#### Features

- LED Driver: CCR NSIC2020 (120 V, 20 mA)
- Constant current as AC voltage increases
- No delay in turn on after LED threshold voltage is reached
- Bright LEDs at low voltages
- LEDs protected from voltage surge

#### Applications

- LED light bulbs
- Rope lights
- Cove lighting
- Accent lighting
- Under-cabinet lighting

#### Resources

- Sample Kit: CCR2KIT/S
- Application Notes and Design Notes available

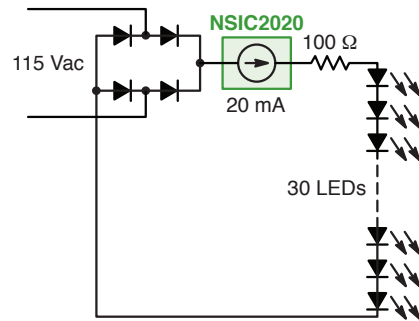

Device	Max Anode-to-Cathode Voltage (V <sub>AK</sub> ) (V)	Voltage Overhead (V <sub>in</sub> - V <sub>LEDs</sub> ) (V)	Constant Current I <sub>reg</sub> (@ V <sub>AK</sub> = 7.5 V) (mA)	Current Tolerance Over Voltage	Max Junction Temperature (°C)	Packages
NSI45xxx	45	1.8	Fixed: 15, 20, 25, 30	±15%, ±10%	150	SOD-123, SOT-223
NSI50xxx	50	1.8	Fixed: 10, 350	±10%	175	SMC, DPAK
NSIC20xx	120	1.8	Fixed: 20, 30, 50	±15%	175	SMB
NSI45xxxJ	45	1.8	Adjustable: 20 to 40, 35 to 70, 60 to 100, 90 to 160	±15%	150	SOT-223, DPAK
NSI50150AD	50	1.8	150 to 350	±10%	175	DPAK

NOTE: xxx in the device number represents the current level.

### Low Cost T5 LED Tube

#### Features

- LED Driver: CCR NSIC2050 (120 V, 50 mA)
- Direct AC drive of LEDs
- No leakage current
- Current regulation to protect LEDs

#### Resources

- Sample Kit: CCR2KIT/S
- Application Notes and Design Notes available

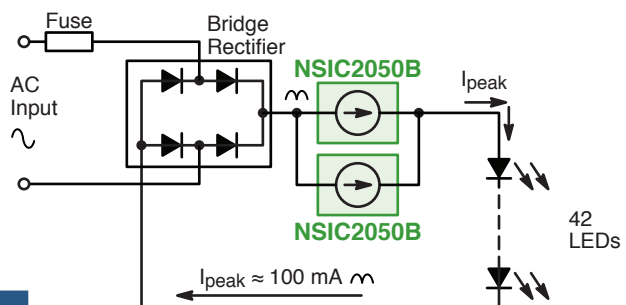

Performances	Input Power (W)	Power Factor	Driver Board	Light Output (Lux)
CCR Direct AC Drive with LEDs	7.1	0.92	6 Parts	3,370

## LED Power Supply for Street and Area Lighting

Generating the light needed to replace an HID or HPS lamp requires a large array of LEDs. LEDs can be configured in various arrangements depending on the end product. There are two different approaches:

### Approach 1

One approach converts the AC input into a regulated DC output voltage that powers multiple parallel LED strips.

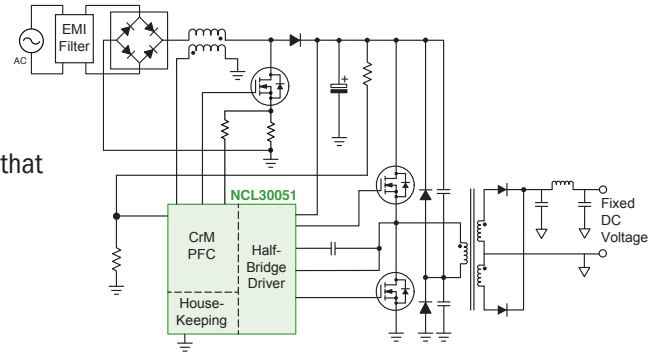

Approach 1

### Approach 2

The second approach provides a regulated constant current to drive the LEDs directly, thus eliminating the linear or DC-DC conversion stage built in to the light strips. This is illustrated in Evaluation Board User's Manual EVBUM2039/D and design note DN05015/D, where the NCL30051 is used to convert 90-265 Vac into a constant current in a power factor corrected half-bridge resonant power supply.

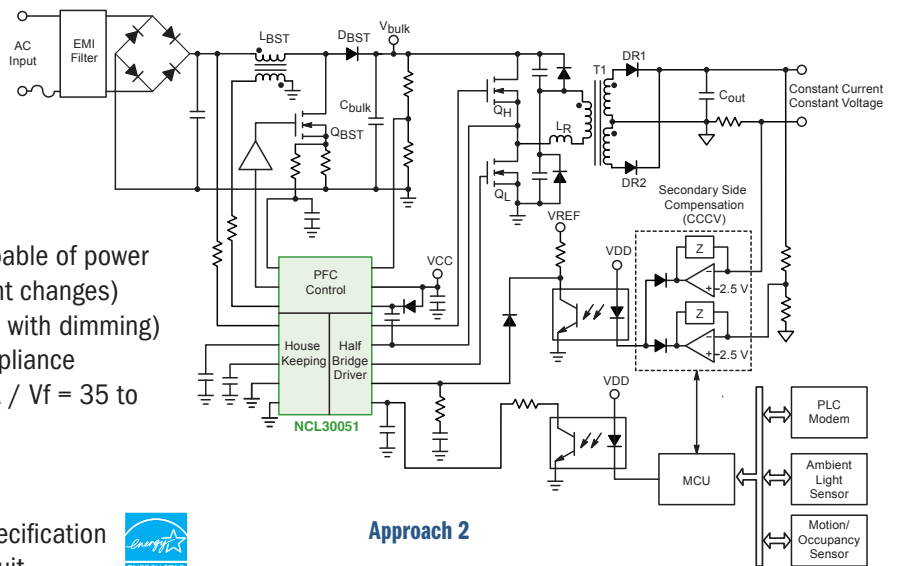

Approach 2

### Features – Approach 2

- Universal Input: 90 – 265 Vac (305 Vac with component change)
- Pout Maximum: 60 W (the NCL30051 is capable of power up to 250 W with component changes)
- Power Factor: PF > 0.9 (50-100% of load with dimming)
- Harmonic Content: IEC61000-3-2 class C compliance
- Efficiency: > 90% with Iout = 1000 mA / Vf = 35 to 45 V
- CC Iout Range: 0.7 – 1.5 A
- Vout Range: 35 – 50 V
- Intended for ENERGY STAR® Luminaires v1.1 specification 
- Protection Features: output open and short circuit protection, over temperature, over current protection – auto recovery, over voltage protection – input (OVP bulk voltage)
- Dimming
  - Two-step bi-level analog
  - 1 – 10 V analog voltage input, 1 = minimum, 10 V is 100% on
  - PWM dimming. Frequency 200 to 400 Hz. Dimming range > 20:1

# BACKLIGHTING

## Medium to Large LCD Panel Backlighting

As LED performance and cost have improved, they are now displacing CCFL lamps in medium and large LCD backlighting applications such as notebooks, monitors, LCD-TVs, personal navigation systems, photo frames, and medical equipment.

Besides eliminating mercury, the use of LEDs allows the design of thinner displays, and improves overall power consumption and lifetime. Integrating an ambient light sensor can further contribute to energy savings while enhancing the user's viewing experience.

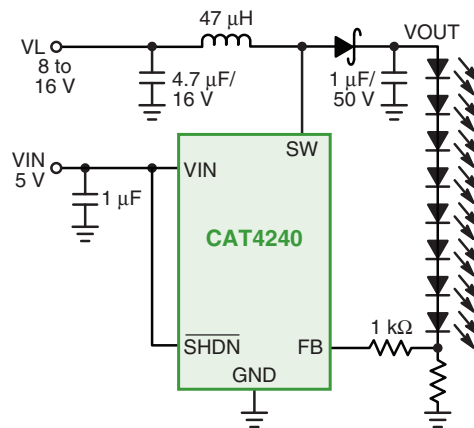
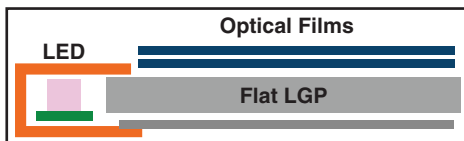
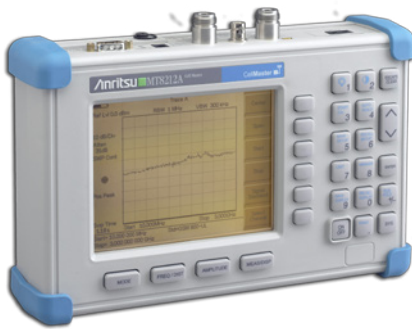

Device	Topology	V <sub>IN</sub> (V)	LEDs	Total I <sub>OUT</sub> Max (mA)	I <sub>SW-LIM</sub> (mA)	V <sub>OUT</sub> Max (V)	Dimming Interface	Package(s)
CAT4237	Inductive Boost	2.0 - 5.5	8	40	450	32	PWM	TSOT-23-5
CAT4238	Inductive Boost	2.0 - 5.5	10	30	450	38	PWM	TSOT-23-5
CAT4240	Inductive Boost	2.0 - 5.5	10	300	850	38	PWM	TSOT-23-5
CAT4106	Inductive Boost / Linear	3.0 - 5.5 / 25	10 x 4	700	1000	36	PWM	TSSOP-16, TQFN-16
CAT4026	6-Channel Linear	-0.3 to 7	Varies	External Transistors			PWM, Analog	S0-28

## 6-Channel LED Controller for Large Panel LED Backlighting – CAT4026

The CAT4026 is a large panel LED controller designed to control 6 constant current high voltage LED strings. Control circuitry monitors the lowest cathode voltage and generates a feedback control signal. Two approaches can be implemented: either a voltage feedback signal is fed into an external DC-DC converter; or a current feedback control is fed directly the main power supply,

converter. Each LED channel current is accurately controlled by sensing an external resistor and controlling a low cost bipolar transistor. LED current in all 6 channels can be controlled by PWM dimming or analog dimming. Fault detection and robust protection is provided for every possible fault scenario on the LED strings.

### Features

- Voltage feedback control to external DC-DC converter
- Current feedback control to main power supply half-bridge resonant converter\*
- PWM and analog dimming
- Zero current shutdown mode
- Auto-recovery fault detection (all modes)
- Shorted cathode-ground (SCG) fault protection
- Shorted cathode-anode (SCA) fault protection
- Open cathode-anode (OCA) fault protection
- Over-voltage protection (OVP)
- Thermal shutdown protection

### Applications

- Large LCD panels backlighting (e.g. LED-TV)
- LED general lighting
- High bay lighting

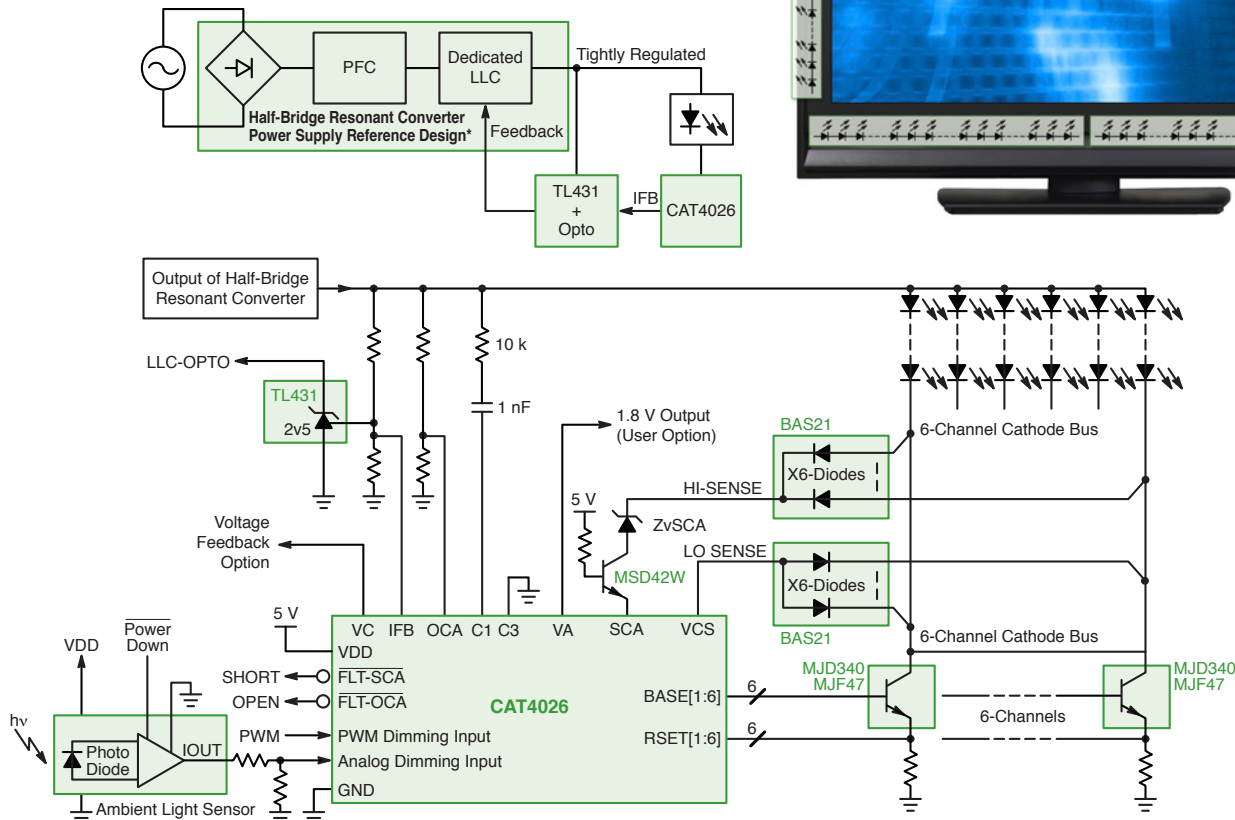

\* Complete power supply reference design for half-bridge resonant converter also available from [www.onsemi.com](http://www.onsemi.com)

## Highly Integrated LED Backlight Controller, Boost Converter and 4 Channel Driver – CAT4106

### Features

- Drives up to 40 (4 x 10) – 36 V per string
- 1 MHz DC-DC boost converter with OVP
- Low dropout LED channels, 500 mV at 175 mA
- Tight channel-to-channel current matching
- Up to 2 kHz PWM dimming interface
- Programmable short and open LED detection
- Thermal shutdown
- Exposed pad packaging, TQFN-16 and TSSOP-16

### Applications

- Notebooks
- Monitors
- Tablets
- Small LCD-TVs
- Test equipment
- Medical instruments
- Touch panels

### Resources

- Evaluation Board CAT4106AGEVB

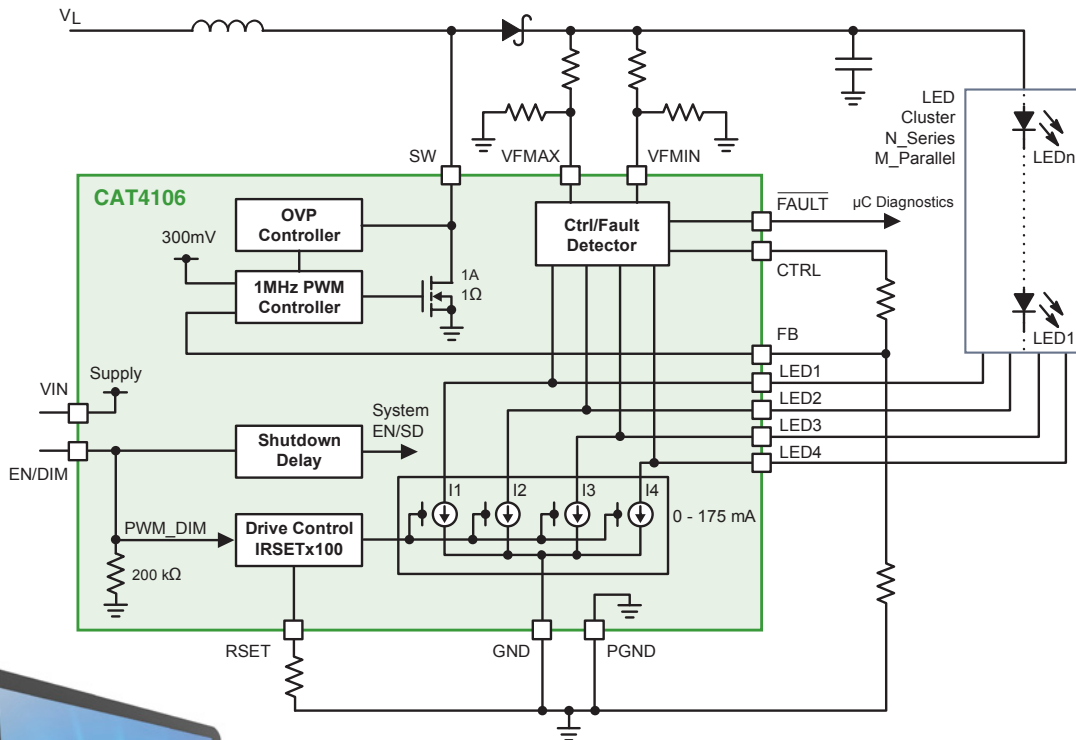

## High Voltage LED Driver – NCP1294

LEDs are replacing CCFL lamps as the light source of choice for large LCD panel backlighting. The circuit described in this design note provides constant current to a long string of LEDs ( $V_f$  ranging from 190 to 230 V) from a single 24 V input. A constant current regulated flyback topology was chosen over a multi-stage boost or a boost plus multiple linear driver channels to improve overall system efficiency and ensure accurate current matching

of the LEDs. Beyond being mercury free, when properly driven and controlled, LEDs can offer a >10x improvement in dimming range over traditional CCFL dimming. This superior dimming range is demonstrated in the design note. This design, based on the robust, flexible NCP1294 controller includes open LED and shorted output protection for safe handling of fault conditions.

### Features

- 1 MHz frequency capability
- 1 A sink/source gate drive
- Programmable pulse-by-pulse overcurrent protection
- Programmable soft start

### Resources

- Design Note DN06062/D

### Applications

- Monitors
- LCD-TVs
- Test equipment
- Medical instruments
- Touch panels

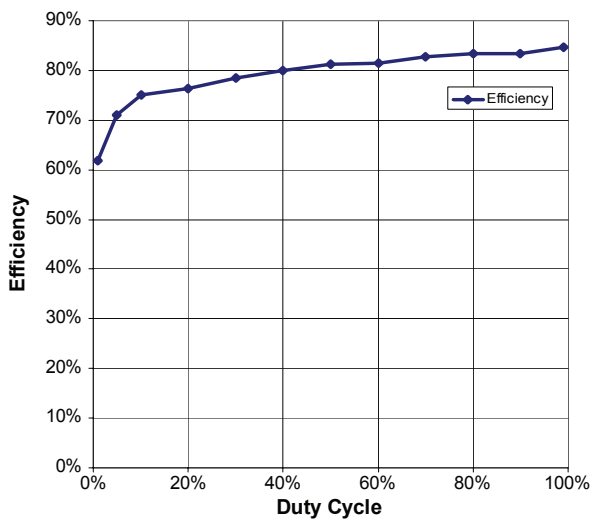

Efficiency vs Dim Duty Cycle

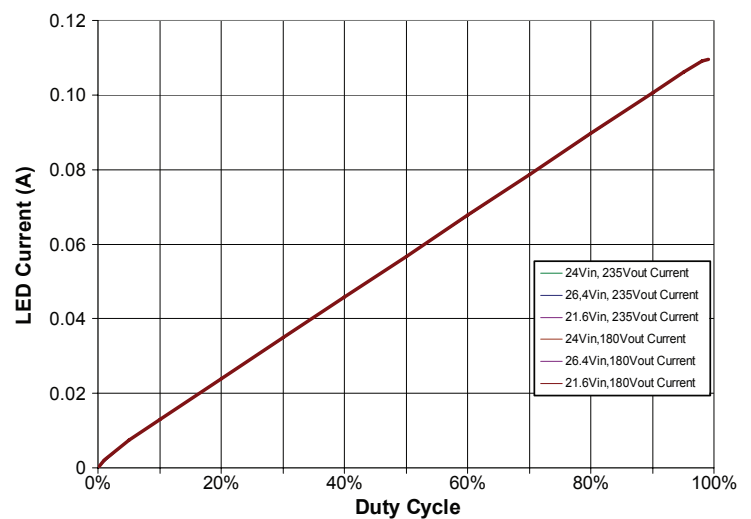

LED PWM Dimming Curve

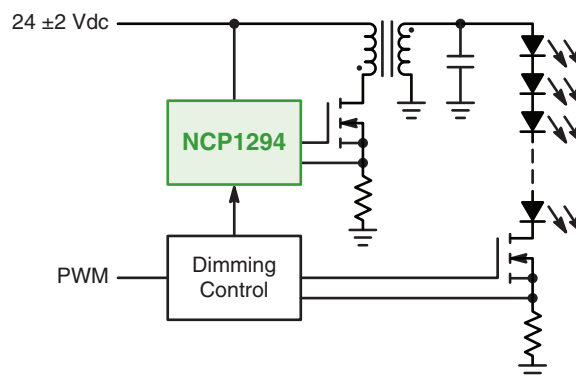

Reference Design Block Diagram

BACKLIGHTING

# COMMUNICATION & SENSING

## Smart Lighting

Smart Lighting involves communication and sensing functions to be able to remotely control (turn on or off, dim or change color) and monitor (remote diagnostic) one or multiple light fixtures in a building, a street or simply at home. Smart Lighting also provides a light fixture with the intelligence to make adjustments based on conditions such as occupancy or ambient light.

Communication can be implemented wirelessly or by using the existing powerline infrastructure. Powerlines make up the largest copper infrastructure in the world. There are electrical outlets at every corner of a home or office building, making it an all-encompassing network. Given that all lighting fixtures connect to a powerline to convert electricity to light, Powerline Communication (PLC) has become a logical way to serve as the primary communication and control link.

For example, two-way communication between a centralized control center and street lights can be implemented to form a fully networked intelligent street light system. This enables municipalities, power utility companies and commercial entities to remotely dim the light output of their street lights, and therefore to reduce the overall energy consumption of their street light network. Two-way communication can be easily implemented on the power line by using PLC modems.

Light fixtures in an office building can be controlled by using the KNX network over an existing twisted pair wiring using KNX transceivers.

Ambient Light Sensors and PIR (Passive Infrared) Detectors such as the NCS36000 can also be used to control the light output of street lighting.

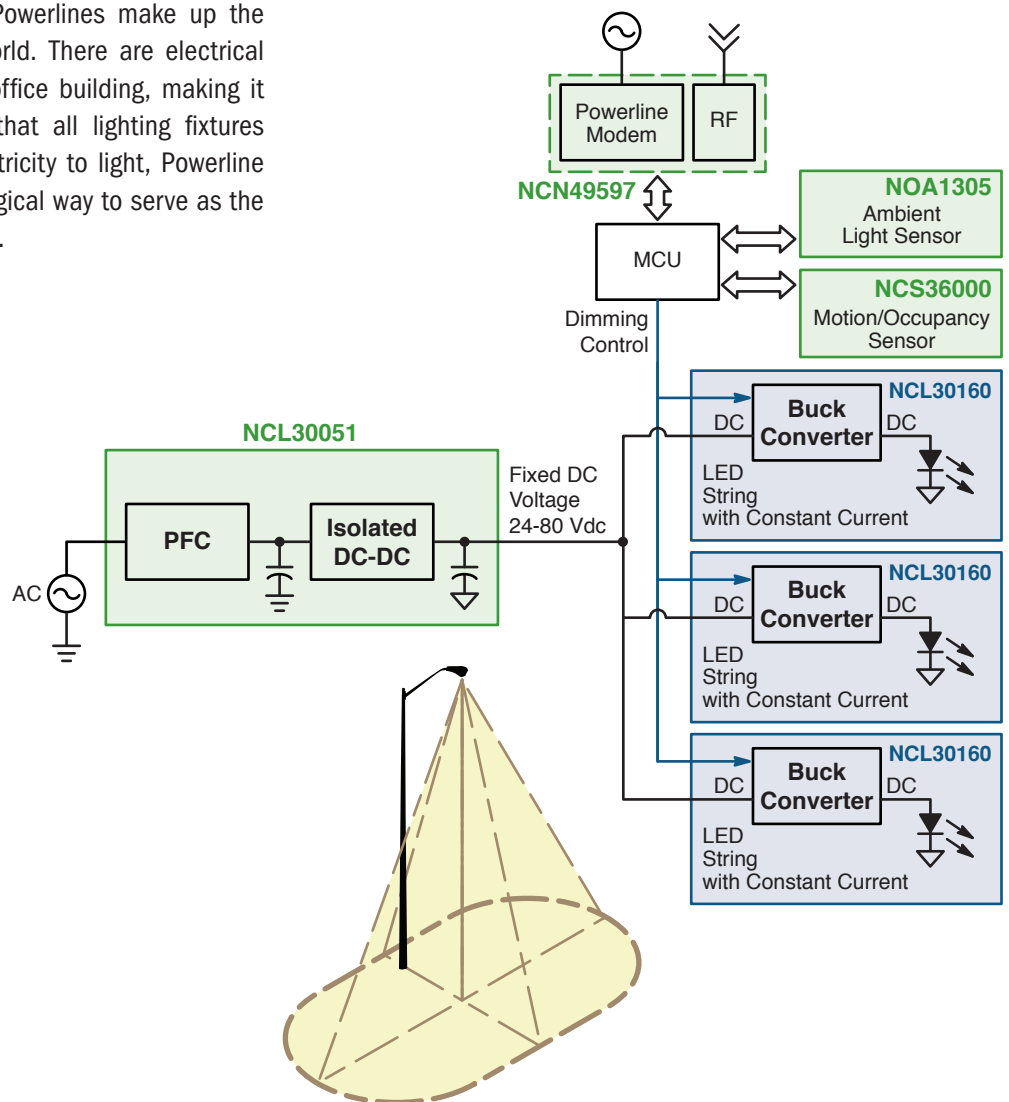

COMMUNICATION & SENSING



## Powerline Communication (PLC) Modems

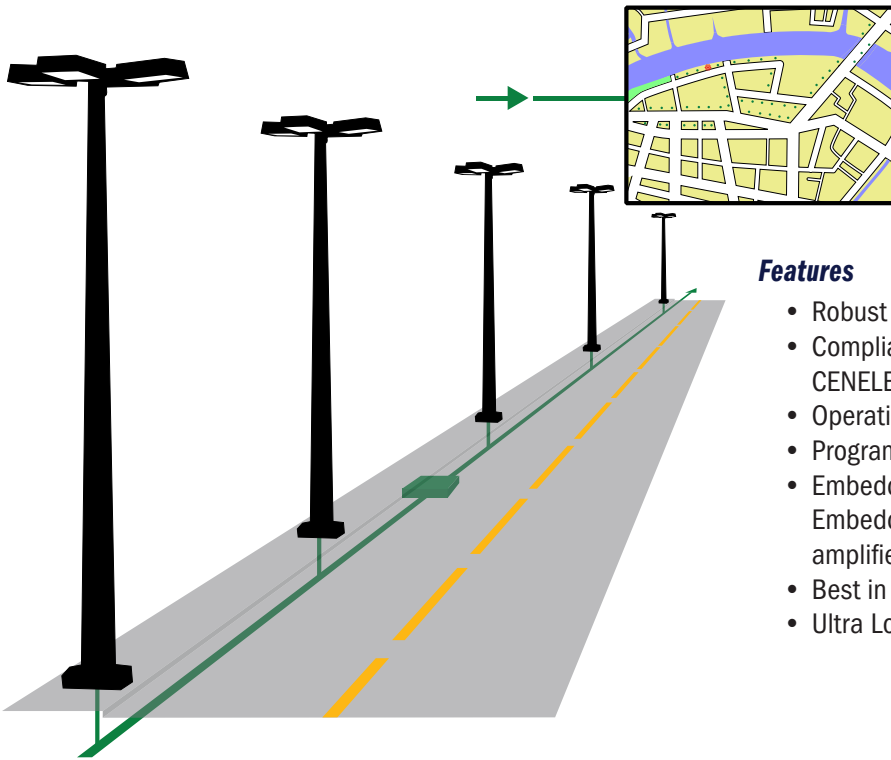

### Features

- Robust narrowband PLC modem up to 10 kBauds
- Compliant with stringent international standards (FCC, CENELEC, IEC61334-5-1)
- Operation on Low Voltage and Medium Voltage network
- Programmable 32-bit ARM Cortex M0 MCU
- Embedded PHY + MAC  
Embedded 1.2 A power amplifier
- Best in class BOM cost
- Ultra Low Power



Device	Max Baudrate per Channel	Number of Channels	Cenelec Band	Embedded MCU	Integrated Power Amplifier	Max Temp	Operation	Auto Baudrate	Robust Mode	Packages	Programmable Software	Program Memory Option	Available Embedded Software Stack
AMIS30585	1200	1	A	ARM7	—	85 °C	AC Only	—	—	PLCC-28	—	ROM	IEC61334-5-1 PLAN
AMIS49587	2400	1	A,B	ARM7	—	85 °C	AC Only	—	—	QFN-52	—	ROM	IEC61334-5-1 PLAN +
NCN49597	4800	2	A,B,C,D	CortexM0	—	125 °C	AC, DC*	Yes	Yes	QFN-52	Yes	ROM	IEC61334-5-1 PLAN +
												RAM	IEC61334-5-1 PLAN + Multicarrier IEC61334-5-1 PLAN + Single/ Multicarrier KNX Full Custom
												RAM	IEC61334-5-1 PLAN + IEC61334-5-1 PLAN + Multicarrier IEC61334-5-1 PLAN + Single/ Multicarrier KNX Full Custom
NCN49599	4800	2	A,B,C,D	CortexM0	Yes	125 °C	AC, DC	Yes	Yes	QFN-56	Yes	ROM	IEC61334-5-1 PLAN +
												RAM	IEC61334-5-1 PLAN + Multicarrier IEC61334-5-1 PLAN + Single/ Multicarrier KNX Full Custom
												RAM	IEC61334-5-1 PLAN + IEC61334-5-1 PLAN + Multicarrier IEC61334-5-1 PLAN + Single/ Multicarrier KNX Full Custom

## KNX Transceivers

KNX is a standardized (EN 50090, ISO/IEC 14543), OSI-based network communications protocol for intelligent buildings. KNX is the successor to, and convergence of, three previous standards:

the European Home Systems Protocol (EHS), BatiBUS, and the European Installation Bus (EIB or Instabus).

### KNX Open Standards

- EN 50090: European Standard
- ISO/IEC 14543-3: International Standard
- GB/Z 20965: Chinese Standard
- ANSI/ASHRAE 135: US Standard

### Applications

- Connects appliances and sensors, especially for climate and light control to the 9600 Baud KNX twisted pair (TP) bus inside a building
- TP bus provides data communication and power supply

Device	DC=DC Converters		20 V Regulator	Embedded MAC + LLC <sup>1</sup>	KNX Host Interface		Package
	Fixed 3.3 V	Adj 3.3 to 21 V			Digital SPI/UART	Analog UART	
NCN5120	✓	✓	✓	✓	✓	✓	QFN-40

Note 1: LLC = Logical Link Control layer of the OSI-based communications network.

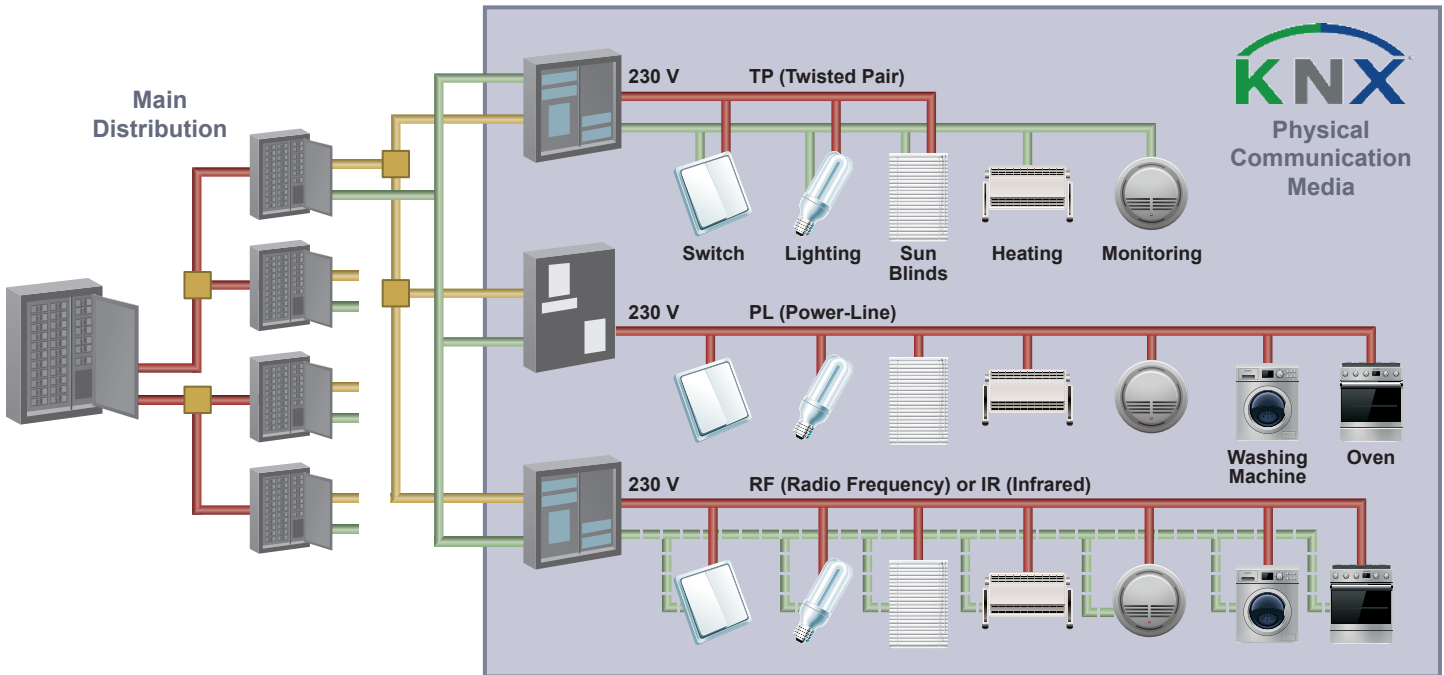

## Motion Detector Passive Infrared Controller (PIR) – NCS36000

- Passive infrared controller circuit for the lighting and occupancy sensing market
- Amplifies and conditions signal from PIR sensor



### Features

- 3.0 – 5.75 V operation
- Integrated low noise 2-stage amplifiers
- Internal voltage reference to drive sensor
- Internal oscillator with external RC
- Single or dual pulse detection
- Digital filter to minimize false alarms
- Direct drive of LED and relay

### Benefits

- Lower BOM cost than comparable discrete solutions
  - Extremely flexible solution
  - Customer can customize digital filtering
- Customer can customize analog processing
- Designed for wide range of occupancy sensors

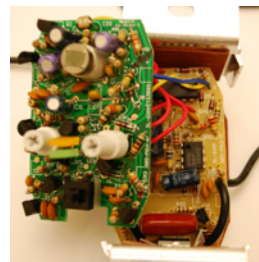
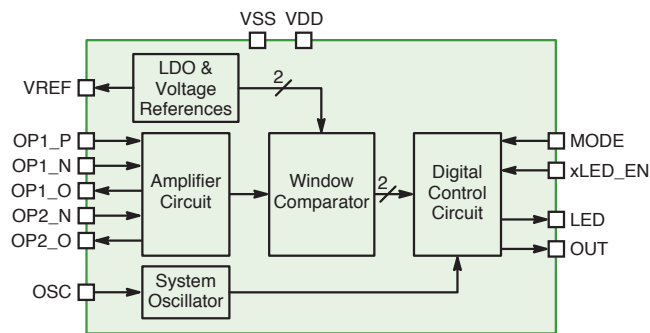

Old Solution



NCS36000 Solution



## Ambient Light & Proximity Sensors

### Features

- Design flexibility/customization (i.e., EEPROM if desired for trimming)
- 0.0125 lux detection with customizable filtering (i.e., Photopic Light Response)
- Dark current and temperature compensation
- Lowest power consumption per resolution bit
- I2C Interface (including High Speed Mode) and no effect on bus during power down

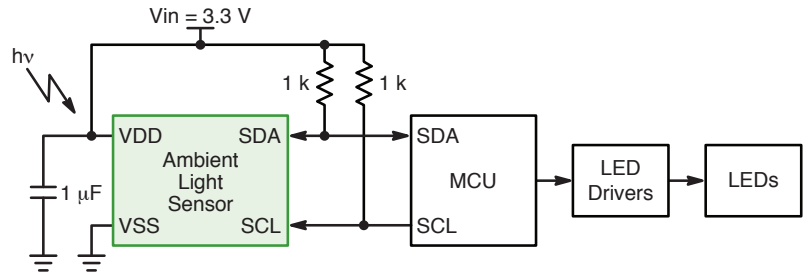

Device	Description	Operating Voltage Range (V)	Operating Temp Range (°C)	Light Sensitivity Range (Lux)	Interface	Package
NOA1212	Analog Ambient Light Sensor with Dark Current Compensation and high gain mode	2.0 to 5.5	-40 to +85	~0.01 to 100K	Analog	CUDFN-6
NOA1305*	Digital Ambient Light Sensor with I2C Interface and Dark Current Compensation	2.0 to 3.6	-40 to +85	0.125 to 100K	I2C (Standard and Fast Modes)	CUDFN-6
NOA2301*	Digital Proximity Sensor with Interrupt	2.3 to 3.6	-40 to +85	–	I2C (Standard, Fast and High-Speed Modes)	CUDFN-6
NOA2302*	Digital Slave Proximity Sensor with Interrupt	2.3 to 3.6	-40 to +85	–	I2C (Standard, Fast and High-Speed Modes)	CUDFN-6
NOA3301	Digital Proximity Sensor with Ambient Light Sensor and Interrupt	2.3 to 3.6	-40 to +85	~0 to 64K	I2C (Standard, Fast and High-Speed Modes)	CUDFN-8

\* Pending 1H14.

# PROTECTION

## LED String Protection – NUD4700

The preferred method of driving LEDs is to have them in strings of LEDs in series, so that currents in the strings are matched for equal brightness. Although LEDs are very reliable, if any single LED were to fail OPEN, the entire string goes dark, because the LEDs within a string are connected in series. This is unacceptable

for high-reliability applications such as street lighting. To solve this issue the NUD4700, from ON Semiconductor, is placed across each LED, and functions as a shunt bypass protector in the event of an LED failing as an OPEN circuit. This ensures that the remainder of the string stays lit.

### Key Requirements

- Low ON-state resistance, high OFF-state resistance and high reliability

### Features

- High ON-state current capability
- Low off-state leakage
- Ability to auto-reset to off-state if LED heals
- low and repeatable response time

### Benefits

- High reliability, enables longevity of string and fixture
- Capable of operating in high current strings

### High Reliability Applications

- Street lights
- Tunnel lighting
- Architectural lighting
- High-bay lighting
- Train and runway lights

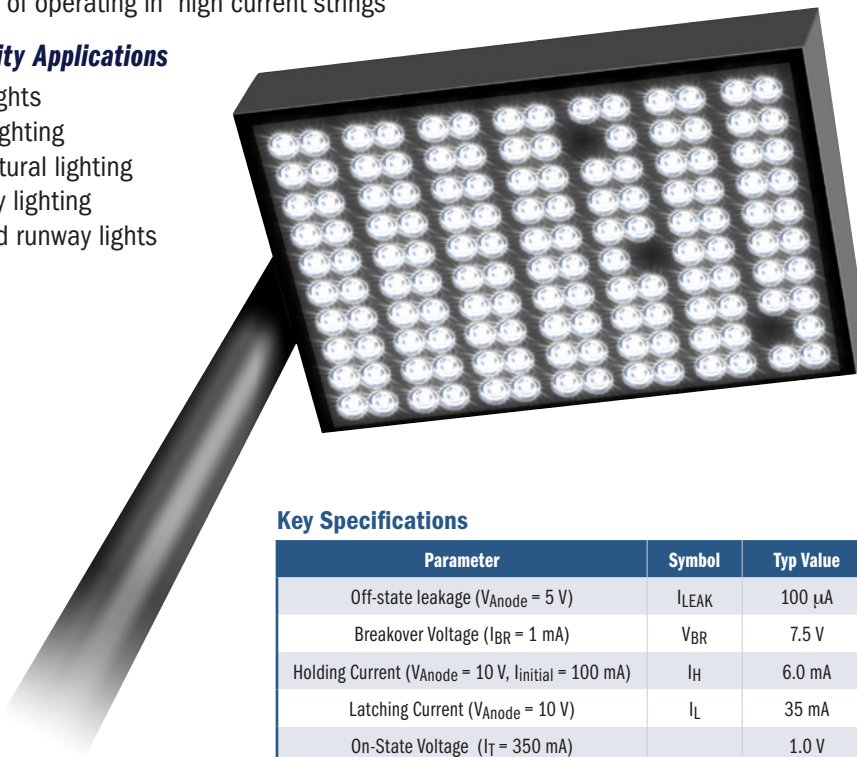

### Key Specifications

Parameter	Symbol	Typ Value
Off-state leakage ( $V_{Anode} = 5\text{ V}$ )	$I_{LEAK}$	100 $\mu\text{A}$
Breakover Voltage ( $I_{BR} = 1\text{ mA}$ )	$V_{BR}$	7.5 V
Holding Current ( $V_{Anode} = 10\text{ V}$ , $I_{initial} = 100\text{ mA}$ )	$I_H$	6.0 mA
Latching Current ( $V_{Anode} = 10\text{ V}$ )	$I_L$	35 mA
On-State Voltage ( $I_T = 350\text{ mA}$ )	$V_T$	1.0 V
On-State Voltage ( $I_T = 750\text{ mA}$ )		1.0 V
On-State Voltage ( $I_T = 1000\text{ mA}$ )		1.0 V

## In-Module ESD Protection of High Brightness LEDs

### Die Level Products for Co-Packaging With HBLED under Optical Dome

During the assembly process and during end-user operation, sensitive HBLED die are susceptible to harmful electro-static discharge (ESD) strikes. Further, during assembly in lamps and light-fixtures, HBLED modules are subject to high-voltage ESD strikes that can destroy them. In-module silicon transient-

voltage suppressor (TVS) die provide the protection needed to eliminate failures and enable the creation of robust HBLED modules for various applications. In-module silicon TVS die come in two forms: as sub-mounted protectors and as side-mounted die.

#### Key Requirements

- ESD protection capability, small footprint for side-mounted protector, low profile

#### Features

- Ability to withstand high levels of ESD strikes
- Low thermal resistance
- Small footprint (side-mount)
- Low profile (side-mount)
- Ability to protect HBLED die during module assembly, and HBLED modules during fixture assembly

#### Benefits

- Prevention of HBLED failure during module assembly and fixture assembly
- Thermal protection and heat-dissipation capability (sub-mount)
- Minimal light-absorption (side-mount)

#### Typical Specifications for Side-Mounted Protector

Parameter	Symbol	Typ Value
Wafer diameter (for the case of wafer-sales)	–	150 mm
Die length	L	250 μm
Die width	W	250 μm
Bondpad diameter	–	190 μm
Positive polarity breakdown voltage (current = 1 mA)	$V_{CL+}$	+7.5 V
Negative polarity breakdown voltage (current = 1 mA)	$V_{CL-}$	-7.5 V
Leakage Current (at 4 V, 25°C)	$I_{LEAK}$	100 nA
ESD Withstand Voltage (HBM)	$V_{ESD}$	±8 kV

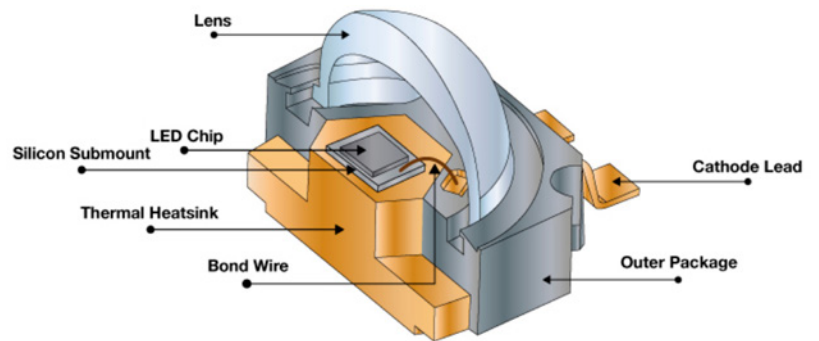

Sub-Mounted Silicon Protector

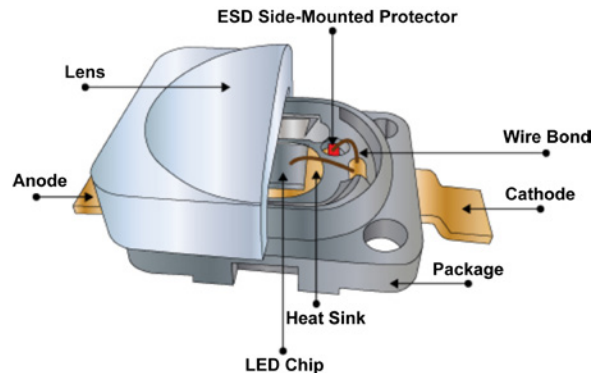

Side-Mounted Silicon Protector

## In-Module TVS Solutions for HBLED Protection

Capability	Options	Details
Die-thickness	100 mm, 150 mm, 200 mm, and 250 mm	Sub-mounts and side-mounts
	(4, 6, 8 and 10 mils)	–
Top Electrodes	Aluminium	–
	Copper	–
	Gold	–
	Aluminium-free Gold	No Aluminium in the system
Back-Metal	Gold	With a thin TiW barrier
	Gold-Tin (Au-Sn)	80%-20% ratio by weight
	TiNiAg	–
	Bare Silicon	For same-side electrodes
Delivery	Unsawn wafers	Customer responsible for backmetal & saw
	Sawn wafers on blue Nitto tape and frame	–
	Sawn wafers on UV tape and frame	–
Electrical Performance	Unidirectional TVS: {+Vz, -1V} See schematic	Vz ranges from 5 V to 200 V
	Bidirectional TVS {+VzP, -VzN} See schematic	VzP and VzN range from 7 V to 200 V
	HBM IEC 61000-4-2	ESD standards supported

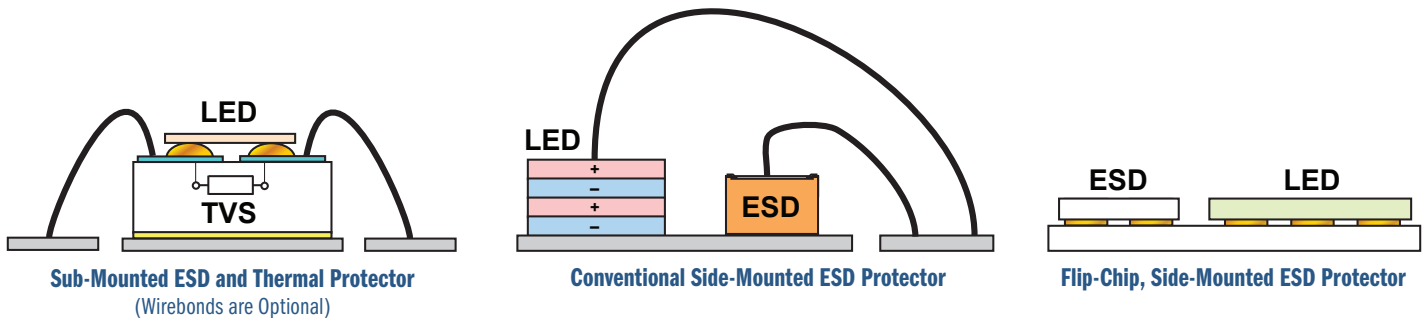
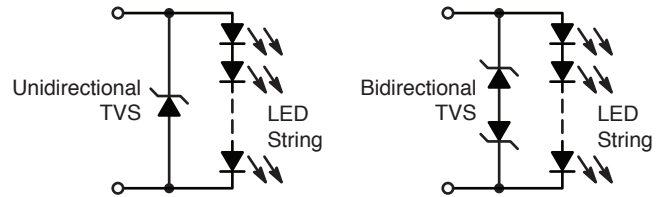

## Sales and Design Assistance from ON Semiconductor

### ON Semiconductor Distribution Partners

Allied Electronics	www.alliedelec.com	(800) 433-5700
Arrow Electronics	www.arrow.com	(800) 777-2776
Avnet	www.em.avnet.com	(800) 332-8638
Chip One Stop, Inc.	www.chip1stop.com/maker/on	(81) 45 470 8771
Daiwa Distribution Ltd.	www.daiwahk.com	(852) 2341 3351
Digi-Key	www.digikey.com	(800) 344-4539
EBV Elektronik	www.ebv.com/en/locations.html	(49) 8121 774-0
Fuji Electronics Co., Ltd.	www.fujiele.co.jp	(81) 3 3814 1770
Future & FAI Electronics	www.futureelectronics.com/contact	1-800-FUTURE1 (388-8731)
KH Electronics Inc.	www.khelec.com/kor	(82) 42 471 8521
Mitsui Electronics Inc.	www.btel.co.jp	(81) 3 6403 5900
Mouser Electronics	www.mouser.com	(800) 346-6873
Newark/Farnell	www.farnell.com/onsemi	(800) 4-NEWARK
OS Electronics Co., Ltd.	www.oselec.jp	Japanese: (81) 3 3255 5985 Other Languages: (81) 3 3255 6066
Promate Electronic Co.	www.promate.com.tw	(886) 2 2659 0303
RS Components KK	jp.rs-online.com	(81) 45 335 8550
Segyung Bristestone Co.	www.bristestone.com	(82) 2 3218 1511
Serial AMSC	www.serialsystem.jp	(81) 3 5302 1569
Serial Microelectronics, HK	www.serialsys.com.hk	(852) 2790 8220
Taewon Inc.	www.taewon.net	(82) 2 6679 9000
World Peace Industries Co.	www.wpi-group.com	(852) 2365 4860
WT Microelectronics Co.	www.wtmec.com	(852) 2950 0820
Yosun Electronics	www.yosun.com.tw	(886) 2 2659 8168

### INTERNATIONAL

<b>GREATER CHINA</b>	Beijing	86-10-8577-8200
	Hong Kong	852-2689-0088
	Shenzhen	86-755-8209-1128
	Shanghai	86-21-5131-7168
	Taipei, Taiwan	886-2-2377-9911
<b>FRANCE</b>	Paris	33 (0)1 39-26-41-00
<b>GERMANY</b>	Munich	49 (0) 89-93-0808-0
<b>INDIA</b>	Bangalore	91-98-808-86706
<b>ISRAEL</b>	Raanana	972 (0) 9-9609-111
<b>ITALY</b>	Milan	39 02 9239311
<b>JAPAN</b>	Tokyo	81-3-5817-1050
<b>KOREA</b>	Seoul	82-2-2190-3500
<b>MALAYSIA</b>	Penang	60-4-6463877
<b>SINGAPORE</b>	Singapore	65-6484-8603
<b>SLOVAKIA</b>	Piestany	421 33 790 2450
<b>UNITED KINGDOM</b>	Slough	44 (0) 1753 70 1676

For a comprehensive listing of ON Semiconductor Sales Offices, please visit:  
[www.onsemi.com/salesupport](http://www.onsemi.com/salesupport)

### AMERICAS REP FIRMS

<b>Alabama</b>	Huntsville	e-Components	(256) 533-2444
<b>Brazil</b>	Countrywide	Ammon & Rizos	(+55) 11-4688-1960
<b>California</b>	Bay Area	Electec	(408) 496-0706
	Southern California	Tech Coast Sales	(949) 305-6869
<b>Canada</b>	Eastern Canada	Astec	(905) 607-1444
<b>Connecticut</b>	Statewide	Paragon Electronic Systems	(603) 645-7630
<b>Florida</b>	Statewide	e-Components	(888) 468-2444
<b>Georgia</b>	Atlanta	e-Components	(888) 468-2444
<b>Illinois</b>	Hoffman Estates	Stan Clothier Company	(847) 781-4010
<b>Indiana</b>	Fishers	Bear VAI	(317) 570-0707
<b>Kansas</b>	Overland Park	Stan Clothier Company	(913) 894-1675
<b>Maine</b>	Statewide	Paragon Electronic Systems	(603) 645-7630
<b>Maryland</b>	Columbia	Third Wave Solutions	(410) 290-5990
<b>Massachusetts</b>	Statewide	Paragon Electronic Systems	(603) 645-7630
<b>Mexico</b>	Countrywide	Ammon & Rizos	(+55) 11-4688-1960
<b>Michigan</b>	St. Joseph	Bear VAI	(440) 526-1991
<b>Minnesota</b>	Eden Prairie	Stan Clothier Company	(952) 944-3456
<b>Missouri</b>	St. Charles	Stan Clothier Company	(636) 916-3777
<b>New Hampshire</b>	Statewide	Paragon Electronic Systems	(603) 645-7630
<b>New Jersey</b>	Statewide	S.J. Metro	(516) 942-3232
<b>New York</b>	Binghamton	TriTech - Full Line Rep	(607) 722-3580
	Jericho	S.J. Metro	(516) 942-3232
	Rochester	TriTech - Full Line Rep	(585) 385-6500
<b>North Carolina</b>	Raleigh	e-Components	(888) 468-2444
<b>Ohio</b>	Brecksville	Bear VAI Technology	(440) 526-1991
<b>Puerto Rico</b>	Countrywide	e-Components	(888) 468-2444
<b>Rhode Island</b>	Statewide	Paragon Electronic Systems	(603) 645-7630
<b>Vermont</b>	Statewide	Paragon Electronic Systems	(603) 645-7630
<b>Wisconsin</b>	Evansville	Stan Clothier Company	(608) 882-0686
	Oconomowoc	Stan Clothier Company	(608) 882-0686

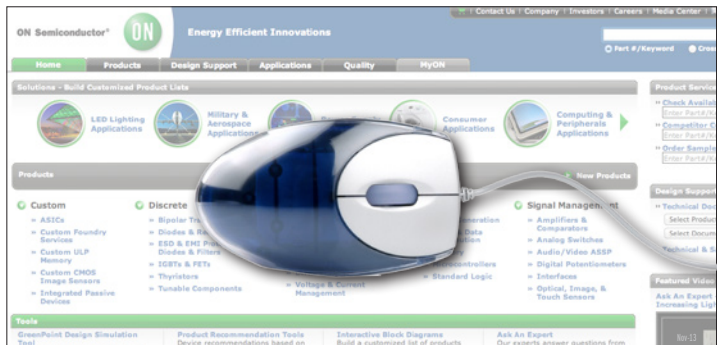

ON Semiconductor and the ON logo are registered trademarks of Semiconductor Components Industries, LLC (SCILLC). SCILLC owns the rights to a number of patents, trademarks, copyrights, trade secrets, and other intellectual property. A listing of SCILLC's product/patent coverage may be accessed at [www.onsemi.com/site/pdf/Patent-Marking.pdf](http://www.onsemi.com/site/pdf/Patent-Marking.pdf). SCILLC reserves the right to make changes without further notice to any products herein. SCILLC makes no warranty, representation or guarantee regarding the suitability of its products for any particular purpose, nor does SCILLC assume any liability arising out of the application or use of any product or circuit, and specifically disclaims any and all liability, including without limitation special, consequential or incidental damages. "Typical" parameters which may be provided in SCILLC data sheets and/or specifications can and do vary in different applications and actual performance may vary over time. All operating parameters, including "Typicals" must be validated for each customer application by customer's technical experts. SCILLC does not convey any license under its patent rights nor the rights of others. SCILLC products are not designed, intended, or authorized for use as components in systems intended for surgical implant into the body, or other applications intended to support or sustain life, or for any other application in which the failure of the SCILLC product could create a situation where personal injury or death may occur. Should Buyer purchase or use SCILLC products for any such unintended or unauthorized application, Buyer shall indemnify and hold SCILLC and its officers, employees, subsidiaries, affiliates, and distributors harmless against all claims, costs, damages, and expenses, and reasonable attorney fees arising out of, directly or indirectly, any claim of personal injury or death associated with such unintended or unauthorized use, even if such claim alleges that SCILLC was negligent regarding the design or manufacture of the part. SCILLC is an Equal Opportunity/Affirmative Action Employer. This literature is subject to all applicable copyright laws and is not for resale in any manner.

### PUBLICATION ORDERING INFORMATION

#### LITERATURE FULFILLMENT:

Literature Distribution Center for ON Semiconductor  
P.O. Box 5163, Denver, Colorado 80217 USA  
Phone: 303-675-2175 or 800-344-3860 Toll Free USA/Canada  
Fax: 303-675-2176 or 800-344-3867 Toll Free USA/Canada  
Email: [orderlit@onsemi.com](mailto:orderlit@onsemi.com)

N. American Technical Support: 800-282-9855 Toll Free  
USA/Canada.

Europe, Middle East and Africa Technical Support:  
Phone: 421 33 790 2910

Japan Customer Focus Center  
Phone: 81-3-5817-1050

ON Semiconductor Website: [www.onsemi.com](http://www.onsemi.com)

Order Literature: <http://www.onsemi.com/orderlit>

For additional information, please contact your local  
Sales Representative