

# AVX Wire-to-Board Connectors



Version 14.8

**AVX**  
A KYOCERA GROUP COMPANY

# Table of Contents

## INSULATION DISPLACEMENT CONNECTORS (IDC)

<b>STANDARD 26-28 AWG</b>	
<b>00-9175</b> .....	<b>2-8</b>
2 Position.....	3
3 Position.....	4
Accessory Cap - Through Wire.....	5
Accessory Cap - Wire Stop.....	6
Hand Insertion Tooling / Clearance Area on PCB for Hand Tooling.....	7
Insertion Tooling Requires Hand Press with Flat Rock Plates.....	8
<b>CAPPED 26-28 AWG</b>	
<b>9175-700</b> .....	<b>9-14</b>
2 Position - Through Wire.....	10
3 Position - Through Wire.....	11
2 Position - Wire Stop.....	12
3 Position - Wire Stop.....	13
Assembly - Through Wire and Wire Stop.....	14
<b>STANDARD 18-24 AWG</b>	
<b>00-9176</b> .....	<b>15-25</b>
1 Position.....	17
2 Position.....	18
3 Position.....	19
Accessory Cap - Through Wire.....	20
Accessory Cap - Wire Stop.....	21
Hand Insertion Tooling for Single 18/24 Gauge Wire.....	22
Insertion Tooling Requires Hand Press with Flat Rock Plates.....	23
Hand Insertion Tooling for One Way Cap Insertion / Clearance Area on PCB for Hand Tooling.....	24
Assembled Connector.....	25
<b>CAPPED 18-24 AWG</b>	
<b>9176-700</b> .....	<b>26-33</b>
1 Position - Through Wire.....	27
2 Position - Through Wire.....	28
3 Position - Through Wire.....	29
1 Position - Wire Stop.....	30
2 Position - Wire Stop.....	31
3 Position - Wire Stop.....	32
Assembly - Through Wire and Wire Stop.....	33
<b>SINGLE IDC CONTACT 22-28 AWG</b>	
<b>9176-400</b> .....	<b>34-39</b>
Contact Details.....	35
PCB Layout.....	36
Assembly Tooling.....	37-38
Cap Details.....	39
<b>SINGLE IDC CONTACT 18-24 AWG</b>	
<b>9176-500</b> .....	<b>40-44</b>
Contact Details.....	41
PBC Layout.....	42
Assembly Tooling.....	43
Cap Details.....	44
<b>STANDARD 14-20 AWG</b>	
<b>00-9177</b> .....	<b>45-52</b>
1 Position.....	47
2 Position.....	48
3 Position.....	49
Assessory Cap - Through Wire.....	50
Assessory Cap - Wire Stop.....	51
Insertion Tooling.....	52

<b>CAPPED THRU HOLE CONNECTOR 12-18 AWG</b>	
<b>00-9177</b> .....	<b>53-55</b>
1 Position - Through Wire.....	54
1 Position - Wire Stop.....	55
<b>SINGLE THRU HOLE IDC 12-18 AWG</b>	
<b>9177-600</b> .....	<b>56-60</b>
Contact Details.....	57
Assembly Tooling.....	58
Accessory Cap - Through Wire.....	59
Accessory Cap - Wire Stop.....	60
<b>POKE-HOME</b>	
<b>HORIZONTAL 18-26 AWG</b>	
<b>00-9276</b> .....	<b>61-68</b>
Wire Assembly/Wire Extraction.....	62
1 Position.....	63
2 Position.....	64
3 Position.....	65
4 Position.....	66
6 Position.....	67
8 Position.....	68
<b>SINGLE HORIZONTAL CONTACT 12-28 AWG</b>	
<b>70-9296</b> .....	<b>69-74</b>
1.7mm.....	70
2mm.....	71
3mm.....	72
4mm.....	73
Connector Assembly / Contact Opening Tool.....	74
<b>VERTICAL TOP ENTRY 18-26 AWG</b>	
<b>00-9296</b> .....	<b>75-82</b>
1 Position.....	76
2 Position.....	77
3 Position.....	78
4 Position.....	79
5 Position.....	80
6 Position.....	81
Connector Assembly / Contact Opening Tool.....	82
<b>INVERTED THRU BOARD 18-26 AWG</b>	
<b>00-9296</b> .....	<b>83-90</b>
1 Position.....	84
2 Position.....	85
3 Position.....	86
4 Position.....	87
5 Position.....	88
6 Position.....	89
Wire Strip Length.....	90
<b>SINGLE VERTICAL CONTACT 18-26 AWG</b>	
<b>70-9296</b> .....	<b>91-86</b>
Top Side Contact - Bottom Entry Wire (FR4 Board).....	92
Through Board Contact - Top Entry Wire (FR4 Board).....	93
Top Side Contact - Bottom Entry Wire (Metal Board).....	94
Through Board Contact - Top Entry Wire (Metal Board).....	95
Wire Trim Details.....	96

NOTICE: Specifications are subject to change without notice. Contact your nearest AVX Sales Office for the latest specifications. All statements, information and data given herein are believed to be accurate and reliable, but are presented without guarantee, warranty, or responsibility of any kind, expressed or implied. Statements or suggestions concerning possible use of our products are made without representation or warranty that any such use is free of patent infringement and are not recommendations to infringe any patent. The user should not assume that all safety measures are indicated or that other measures may not be required. Specifications are typical and may not apply to all applications.

# Standard 26-28 AWG: WTB

00-9175



The 917X series of surface mount Insulation Displacement Connectors (IDC) were developed to meet the harsh automotive and industrial market applications for connecting individual wires directly to a PCB ranging from 14 AWG to 28 AWG. This industry proven contact system has been tested to automotive levels of shock, vibration, and temperature cycling to prove their reliability and robustness. The simplicity of inserting a wire into the connector with a small tool allows a wide range of devices to be connected to the PCB without soldering. In SSL applications specifically, these connectors are used to bring power and signal onto the PCB or are used to daisy chain multiple boards together in a long string. While the IDC contact provides a gas-tight connection to conductor of the wire, the housing has been designed to grab the insulation of the wire to provide a positive strain relief even in the harshest conditions. In case of repair, the wires can be removed and replaced up to three times.

The 9175 series accepts 26 AWG to 28 AWG wires with an insulation diameter ranging from 0.7mm to 1.0mm. These single contact connectors support a 1 amp current rating and have a split SMT tail design to provide maximum stability on the PCB. Available in a 2p and 3p configuration, these connectors can be end stackable for higher pin counts.

## APPLICATIONS

- Connecting discrete wire components directly to the PCB
- Bringing power and signals onto a PCB
- Daisy chaining PCB's together to create a continuous string of boards
- Application Notes: refer to 201-01-124

## FEATURES AND BENEFITS

- IDC contact provides a gas-tight connection to the PCB for long term reliability
- Connector housing captures the wire insulation for positive strain relief
- Tested to automotive levels on shock, vibration and temperature cycling for reliability
- Low and high volume assembly tools to match production volumes
- Reduced total applied cost versus solder or crimp processes
- High temperature insulator capable to 260 degrees C reflow soldering processes

## ELECTRICAL

- Current Rating: 1 Amp / Contact
- Voltage Rating: 150 VAC

## ENVIRONMENTAL

- Operating Temperature: -40°C to +125°C

## MECHANICAL

- Insulator Material: Nylon 46: UL94V0
- Contact Material: Phosphor Bronze
- Plating: Tin over Nickel
- Durability: 3 Cycles

## HOW TO ORDER

<b>00</b>	<b>9175</b>	<b>00X</b>	<b>001</b>	<b>X</b>	<b>06</b>	
Prefix	Series	Number of Ways	Wire Gauge Size	Insulator Color	Plating Option	

Code	No of Ways	Details
002	2	Page 3
003	3	Page 4

Code	Accepted Wire Gauge	Wire Insulation
001	28 Gauge Solid or Stranded 26 Gauge Solid or Stranded	Min Ø 0.70 Max Ø 1.00

9 = UL White	8 = UL Black	Special Order
06 = Pure Tin all over		

## CONNECTOR/TOOLING PART NUMBER MATRIX

SERIES 9175 IDC					HAND INSERTION TOOLING*			ACCESSORY CAPS	
AWG	Wire Insulation	Positions	Color	Part Number	Plastic (medium volume)	Metal (high volume)	Mass Termination	Though Wire	Wire Stop
26	Ø 0.7 - 1.0	2p	White	009175002001906	069175701601000	069175701701000	069175701701002	609175002010100	609175002010199
26	Ø 0.7 - 1.0	2p	Black	009175002001806	069175701601000	069175701701000	069175701701002	609175002010000	609175002010099
26	Ø 0.7 - 1.0	3p	White	009175003001906	069175701601000	069175701701000	069175701701003	609175003010100	609175003010199
26	Ø 0.7 - 1.0	3p	Black	009175003001806	069175701601000	069175701701000	069175701701003	609175003010000	609175003010099
28	Ø 0.7 - 1.0	2p	White	009175002001906	069175701601000	069175701701000	069175701701002	609175002010100	609175002010199
28	Ø 0.7 - 1.0	2p	Black	009175002001806	069175701601000	069175701701000	069175701701002	609175002010000	609175002010099
28	Ø 0.7 - 1.0	3p	White	009175003001906	069175701601000	069175701701000	069175701701003	609175003010100	609175003010199
28	Ø 0.7 - 1.0	3p	Black	009175003001806	069175701601000	069175701701000	069175701701003	609175003010000	609175003010099

\* Hand Insertion Tooling - Universal Hand Tool 067000773001000; Consult Application Notes 201-01-124

Certification: UL File #E90723

### 26-28 AWG 2 WAY IDC CONNECTOR

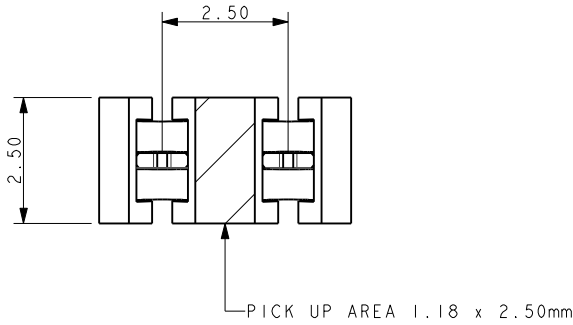

**NOTES:**

1. CONNECTOR FOR IDC WIRE TO BOARD CONNECTION.
2. CONTACT MATERIAL: PHOSPHOR BRONZE.  
INSULATION MATERIAL: HIGH TEMPERATURE NYLON 46.  
COLOR REFER TO PAGE 2.
3. CONNECTOR DESIGNED TO ACCEPT 26 AND 28 GAUGE SOLID OR STRANDED WIRE.
4. ALL DIMENSIONS FOR REFERENCE UNLESS OTHERWISE STATED.
5. FOR FULL PRODUCT SPECIFICATION REFER TO ELCO SPEC 201-01-100.

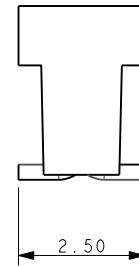
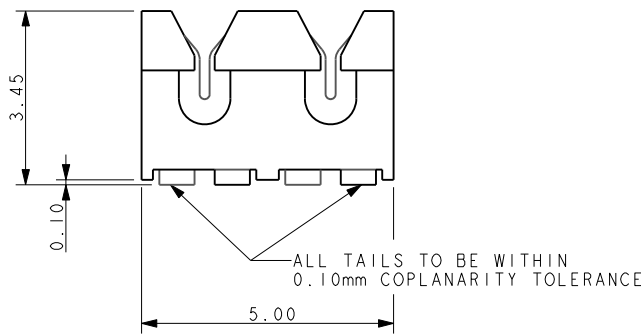

### SMT PCB LAYOUT

PURE TIN PADS

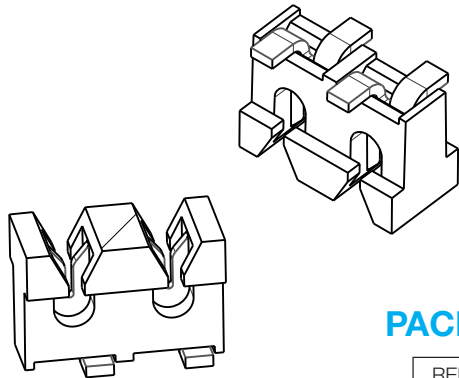
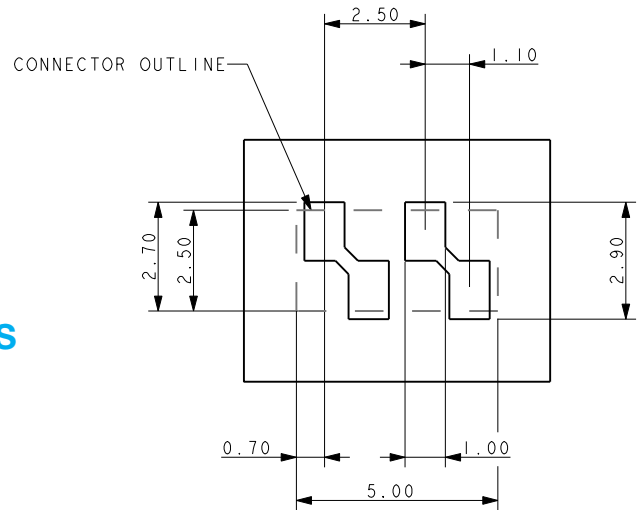

### PACKING DETAILS

REEL QTY	2000
LEADER	500MM
TRAILER	500MM
REEL / BOX	7
PACK QTY	14000

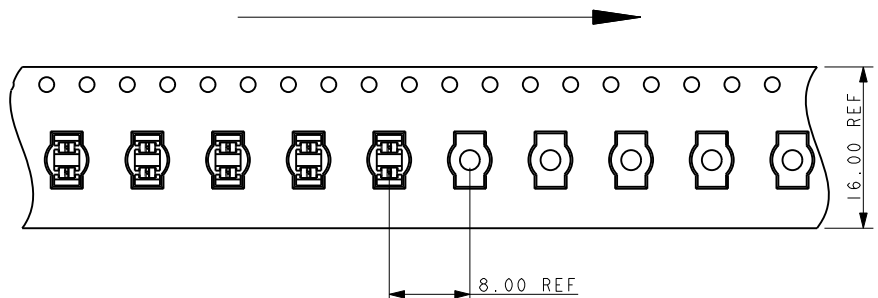
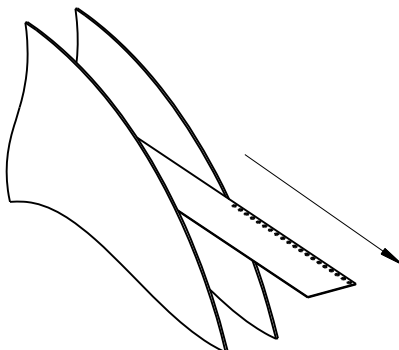

### 26-28 AWG 3 WAY IDC CONNECTOR

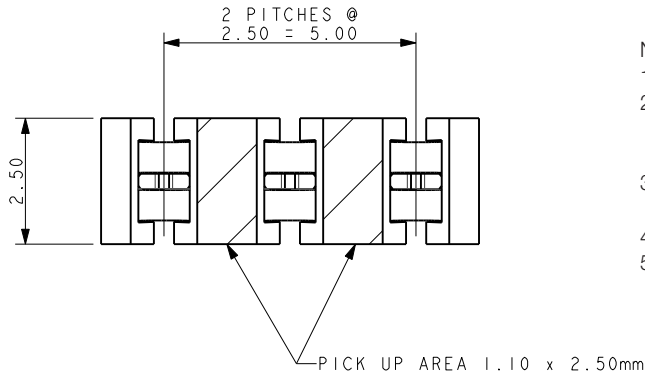

**NOTES:**

1. CONNECTOR FOR IDC WIRE TO BOARD CONNECTION.
2. CONTACT MATERIAL: PHOSPHOR BRONZE.  
INSULATION MATERIAL: HIGH TEMPERATURE NYLON 46.  
COLOR REFER TO PAGE 2.
3. CONNECTOR DESIGNED TO ACCEPT 26 AND 28 GAUGE SOLID OR STRANDED WIRE.
4. ALL DIMENSIONS FOR REFERENCE UNLESS OTHERWISE STATED.
5. FOR FULL PRODUCT SPECIFICATION REFER TO ELCO SPEC 201-01-100.

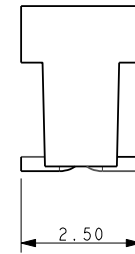
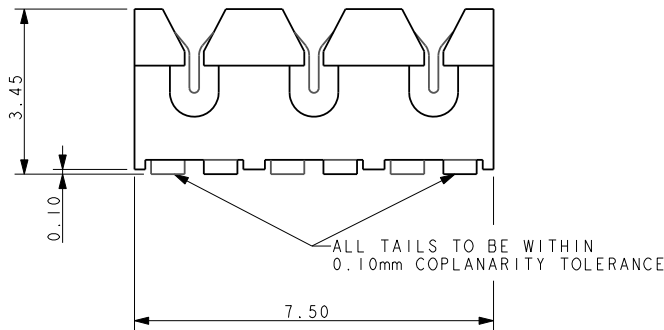

### SMT PCB LAYOUT

PURE TIN PADS

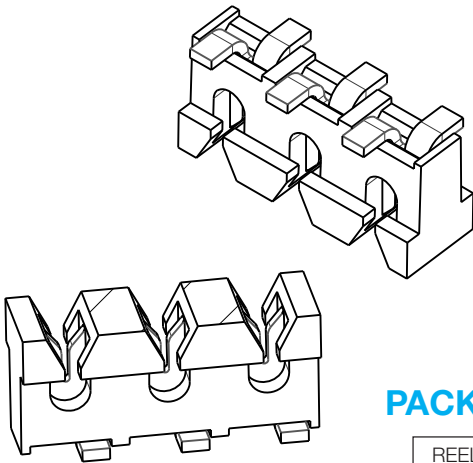
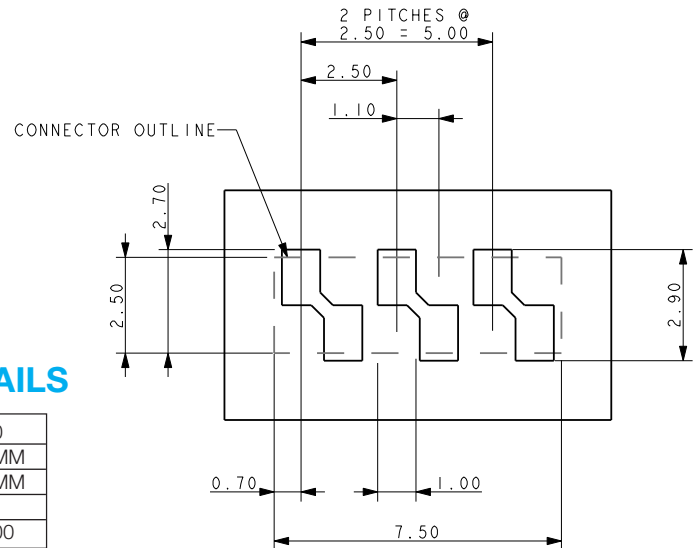

### PACKING DETAILS

REEL QTY	2000
LEADER	500MM
TRAILER	500MM
REEL / BOX	7
PACK QTY	14000

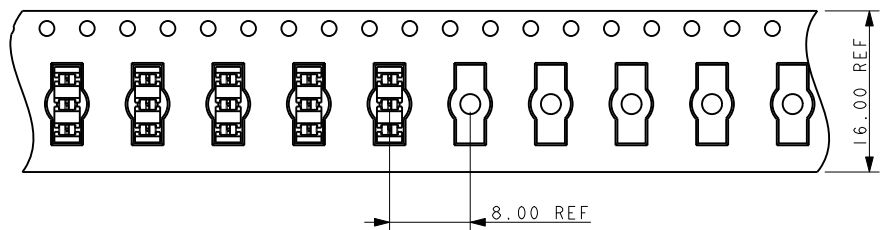
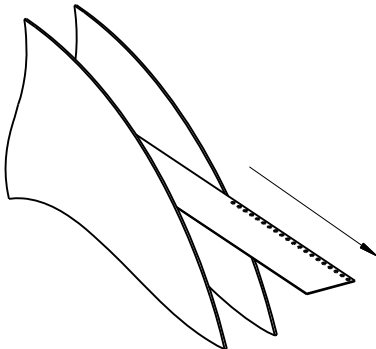

### 60-9175-00X-010-X00 ACCESSORY CAP – THROUGH WIRE

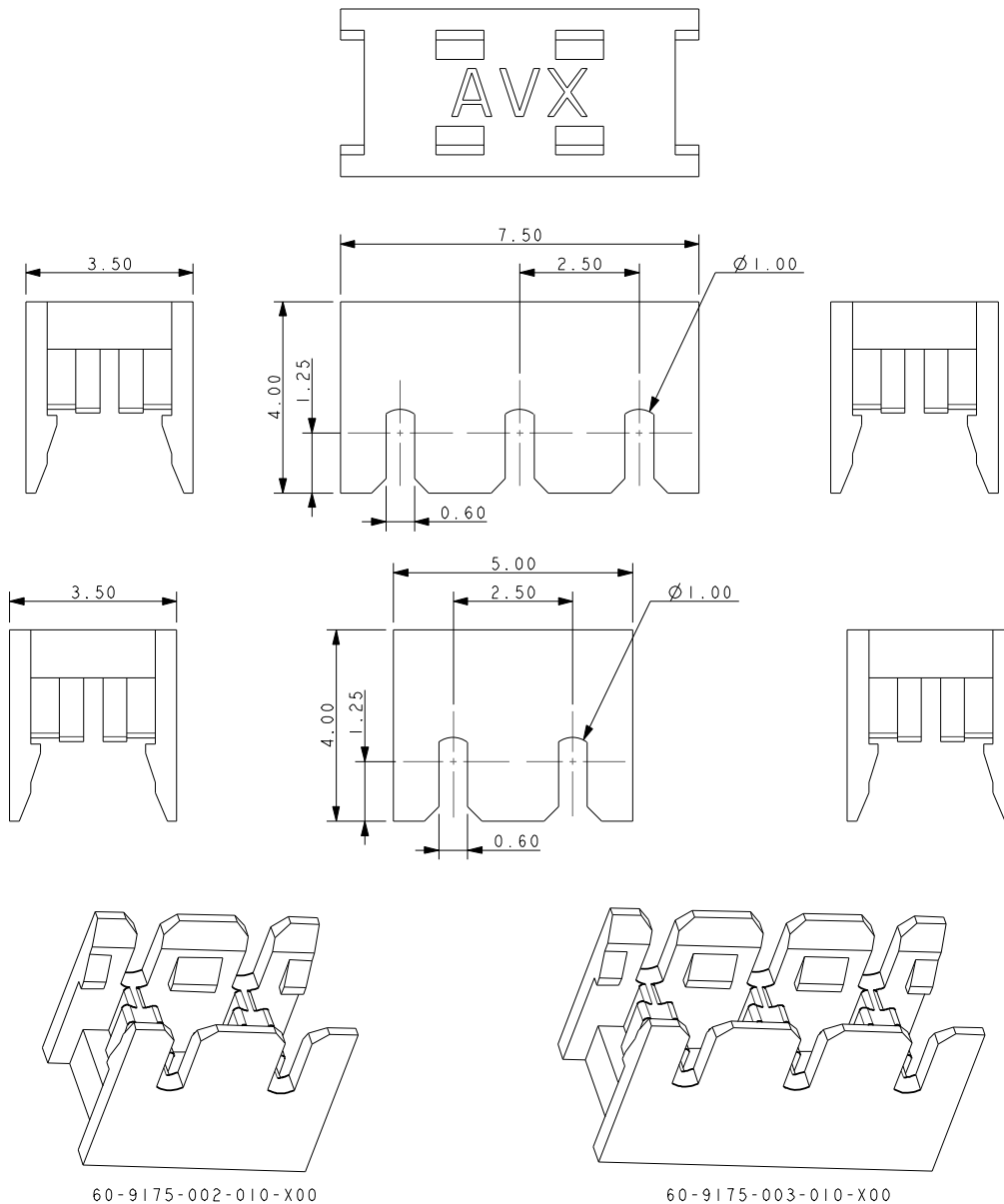

#### NOTES:

1. CAP FOR IDC WIRE TO BOARD CONNECTION, 2 AND 3 WAY, THROUGH WIRE.
2. THROUGH WIRE CAP CAN BE USED AT ANY POSTION ALONG A WIRE.
3. FOR USE WITH STANDARD 9175 IDC CONNECTORS
4. CAP MATERIAL: GLASS FILLED NYLON 46, FOR COLORS SEE PAGE 2.
5. CAPS DESIGNED TO ACCOMMODATE WIRES WITH INSULATION UP TO 1.00MM DIAMETERS.
6. GENERAL TOLERANCE  $\pm 0.20$ .
7. PACKED IN BAGS, 1000 PIECES PER BAG.

### 60-9175-00X-0XX-010-X99 ACCESSORY CAP – WIRE STOP

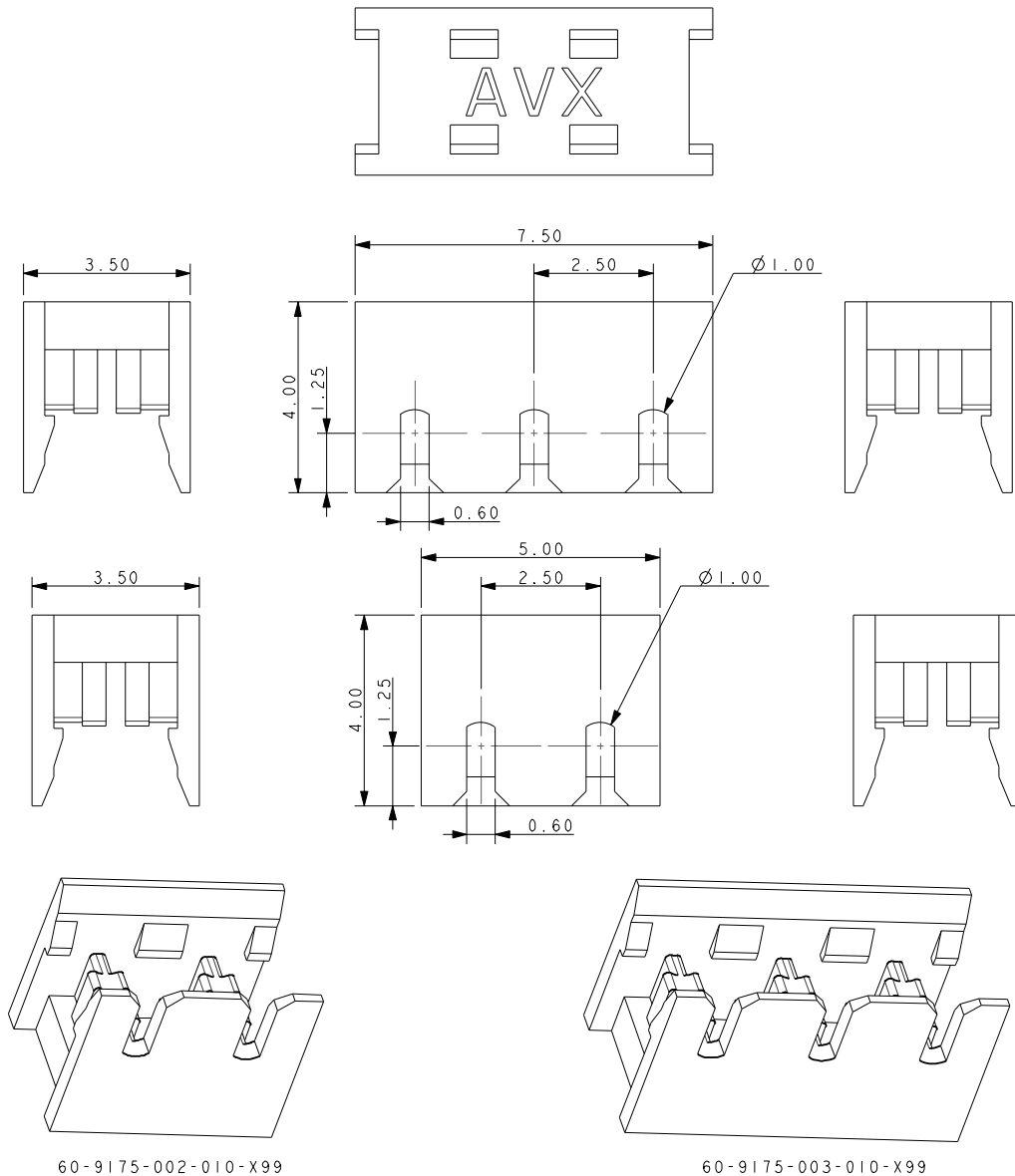

#### NOTES:

1. CAP FOR IDC WIRE TO BOARD CONNECTION, 2 AND 3 WAY, WIRE STOP.
2. WIRE STOP CAP FOR USE AT WIRE ENDS, STOP FACE PROTECTS THE WIRE ENDS.
3. FOR USE WITH STANDARD 9175 IDC CONNECTORS
4. CAP MATERIAL: GLASS FILLED NYLON 46, FOR COLORS SEE PAGE 2.
5. CAPS DESIGNED TO ACCOMMODATE WIRES WITH INSULATION UP TO 1.00MM DIAMETERS.
6. GENERAL TOLERANCE  $\pm 0.20$ .
7. PACKED IN BAGS, 1000 PIECES PER BAG.

### HAND INSERTION TOOLING SINGLE WIRE INSERTION TOOL FOR 26/28 GAUGE WIRE

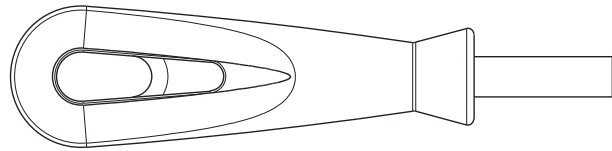

#### UNIVERSAL HANDLE

Details	Tool Part Number
6.35 A/F HEX BIT HOLDER	06 7000 7730 01 000

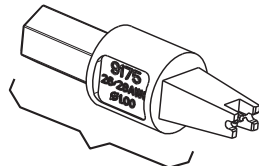

ALL METAL

#### HIGH PRODUCTION Metal

Max Insulation Dia	Tool Part Number
∅ 1.00	06 9175 7017 01 000

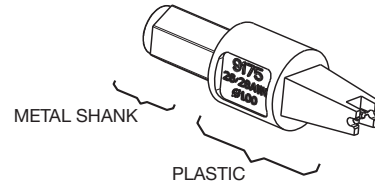

METAL SHANK

PLASTIC

#### MEDIUM PRODUCTION Metal/Plastic

Max Insulation Dia	Tool Part Number
∅ 1.00	06 9175 7016 01 000

### CLEARANCE AREA ON PCB FOR HAND TOOLING

#### 2 WAY

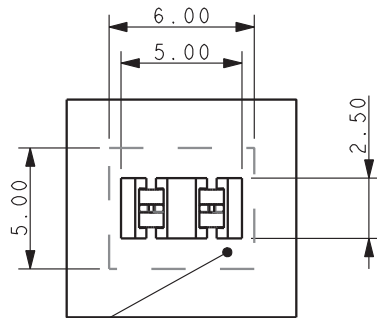

AREA TO BE KEPT CLEAR FOR TOOLING

#### 3 WAY

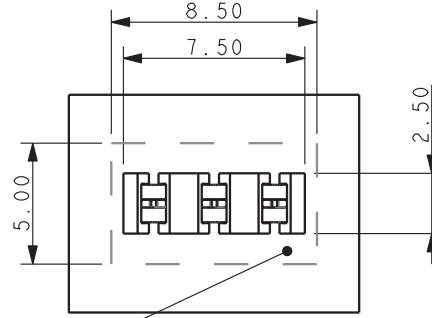

AREA TO BE KEPT CLEAR FOR TOOLING



### INSERTION TOOLING REQUIRES HAND PRESS WITH FLAT ROCK PLATES

#### 2 WAY TOOL

TOOL NUMBER 06-9175-7017-01-002

SKETCH SHOWS PCB RESTRICTED AREAS FOR ASSEMBLY TOOLING

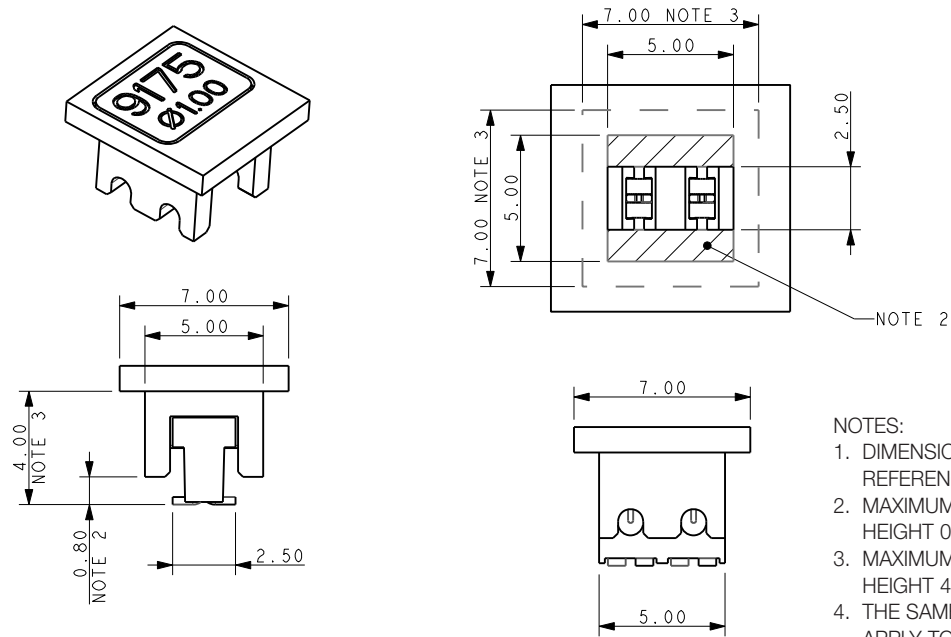

#### NOTES:

1. DIMENSIONS SHOWN ARE REFERENCE DIMENSIONS.
2. MAXIMUM COMPONENT HEIGHT 0.80MM IN THIS AREA.
3. MAXIMUM COMPONENT HEIGHT 4.00MM IN THIS AREA.
4. THE SAME RESTRICTIONS APPLY TO ALL WIRE INSULATION DIAMETERS.

#### 3 WAY TOOL

TOOL NUMBER 06-9175-7017-01-003

SKETCH SHOWS PCB RESTRICTED AREAS FOR ASSEMBLY TOOLING

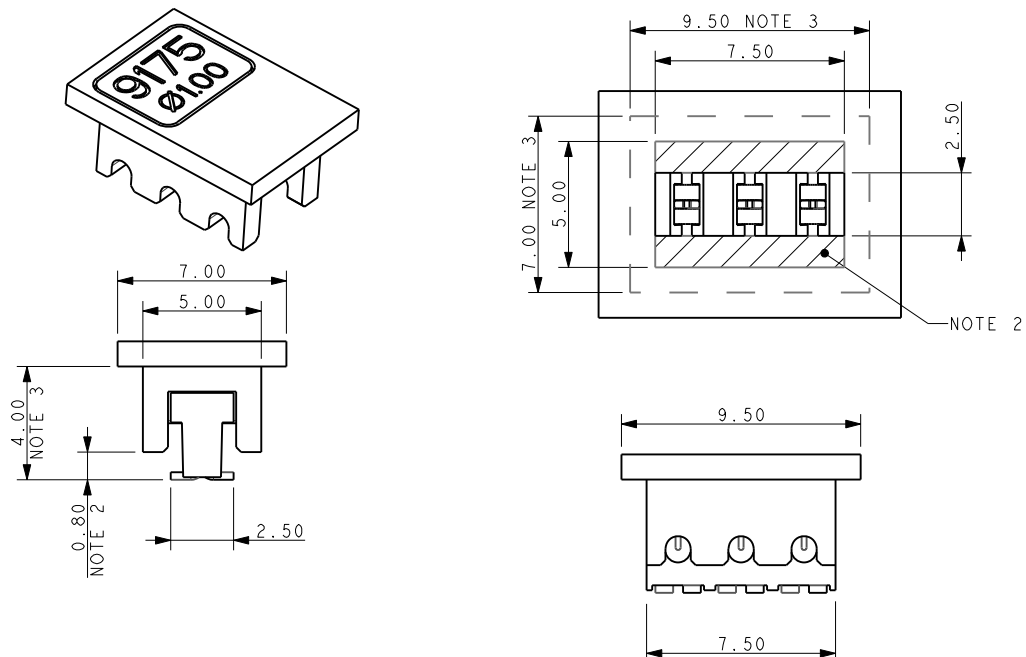

# Capped IDC 26-28 AWG: WTB

9175-700



The market and applications for simple and reliable discrete Wire-to-Board connectors continue to evolve. AVX first introduced the 9175 series of surface mountable Insulation Displacement Connectors (IDC) in 2006. Developed for harsh industrial and automotive applications, these connectors have been used in hundreds of applications from today's "Smart Meter" all the way down to a simple sensor termination to a PCB. Size and performance has been one of the key factors for selecting this connector in terminating 26-28AWG wires to a PCB.

The next generation of IDC connector moves beyond all of the technical and performance attributes to address the "User Friendliness" of the product. By changing the insulator from acting as a connector body and make it more like a contact carrier, the insulator becomes the wire location and insertion aid without any special tools. The wire is just inserted into the cap (no stripping required) and then pressed down to provide a secure "Gas Tight" termination. This configuration simplifies and cost reduces the entire wire termination process for connecting discrete wires to a PCB.

## APPLICATIONS

- Connecting discrete wire components to a PCB
- Bringing power and signals onto a PCB
- Daisy chaining PCB's together to create a continuous string
- Reference Product Specification 201-01-140

## FEATURES AND BENEFITS

- IDC contact provides a gas-tight connection to the PCB for long term reliability
- Plastic cap retains the contacts in position prior to automatic placement, then acts as the assembly tool to terminate the wires; no special tooling.
- Tested to automotive levels on shock, vibration and temperature cycling for reliability
- Identical contact and footprint pattern to the existing 9175 for full backward compatibility and functionality
- The IDC contact reduces the total applied cost versus solder or crimp processes
- Connectors are available in two configurations for maximum flexibility; End and Through Wire

## ELECTRICAL

- Current Rating: 1 Amps / Contact
- Voltage Rating: 150 VAC

## ENVIRONMENTAL

- Operating Temperature: -40°C to +125°C

## MECHANICAL

- Insulator Material: Nylon UL94VO
- Contact Material: Phosphor Bronze
- Plating: Tin over Nickel
- Durability 3 Cycles

## HOW TO ORDER

<b>00</b>	<b>9175</b>	<b>00X</b>	<b>70X</b>	<b>X</b>	<b>X</b>	<b>6</b>																														
Prefix	Series	Number of Ways	Wire Gauge Size Cap Pre-Assembled	Insulator Color	Cap Options	Plating Option																														
		<table border="1"> <thead> <tr> <th>Code</th> <th>No of Ways</th> <th>Details</th> </tr> </thead> <tbody> <tr> <td>002</td> <td>2</td> <td>Pages 10 &amp; 12</td> </tr> <tr> <td>003</td> <td>3</td> <td>Pages 11 &amp; 13</td> </tr> </tbody> </table>	Code	No of Ways	Details	002	2	Pages 10 & 12	003	3	Pages 11 & 13	<table border="1"> <thead> <tr> <th>Code</th> <th>Accepted Wire Gauge</th> <th>Wire Insulation</th> </tr> </thead> <tbody> <tr> <td>701</td> <td>28 Gauge Solid or Stranded</td> <td>Min Ø 0.70 Max Ø 1.00</td> </tr> <tr> <td>702</td> <td>26 Gauge Solid or Stranded</td> <td>Min Ø 0.80 Max Ø 1.20</td> </tr> </tbody> </table>	Code	Accepted Wire Gauge	Wire Insulation	701	28 Gauge Solid or Stranded	Min Ø 0.70 Max Ø 1.00	702	26 Gauge Solid or Stranded	Min Ø 0.80 Max Ø 1.20	9 = UL White 8 = UL Black Special Order	<table border="1"> <thead> <tr> <th>Code</th> <th>Cap Option</th> <th>Description</th> <th>Detail</th> </tr> </thead> <tbody> <tr> <td>0</td> <td>Through Wire</td> <td>Allows wire to be terminated at any point</td> <td>Page 10 -11</td> </tr> <tr> <td>9</td> <td>Wire Stop</td> <td>Terminates end of wire End Protected by stop face</td> <td>Pages 12-13</td> </tr> </tbody> </table>	Code	Cap Option	Description	Detail	0	Through Wire	Allows wire to be terminated at any point	Page 10 -11	9	Wire Stop	Terminates end of wire End Protected by stop face	Pages 12-13	6 = Pure Tin all over
Code	No of Ways	Details																																		
002	2	Pages 10 & 12																																		
003	3	Pages 11 & 13																																		
Code	Accepted Wire Gauge	Wire Insulation																																		
701	28 Gauge Solid or Stranded	Min Ø 0.70 Max Ø 1.00																																		
702	26 Gauge Solid or Stranded	Min Ø 0.80 Max Ø 1.20																																		
Code	Cap Option	Description	Detail																																	
0	Through Wire	Allows wire to be terminated at any point	Page 10 -11																																	
9	Wire Stop	Terminates end of wire End Protected by stop face	Pages 12-13																																	



Certification: UL File #E90723

### 26-28 AWG 2 WAY IDC CONNECTOR THROUGH WIRE CAPPED IDC

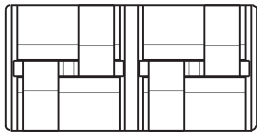
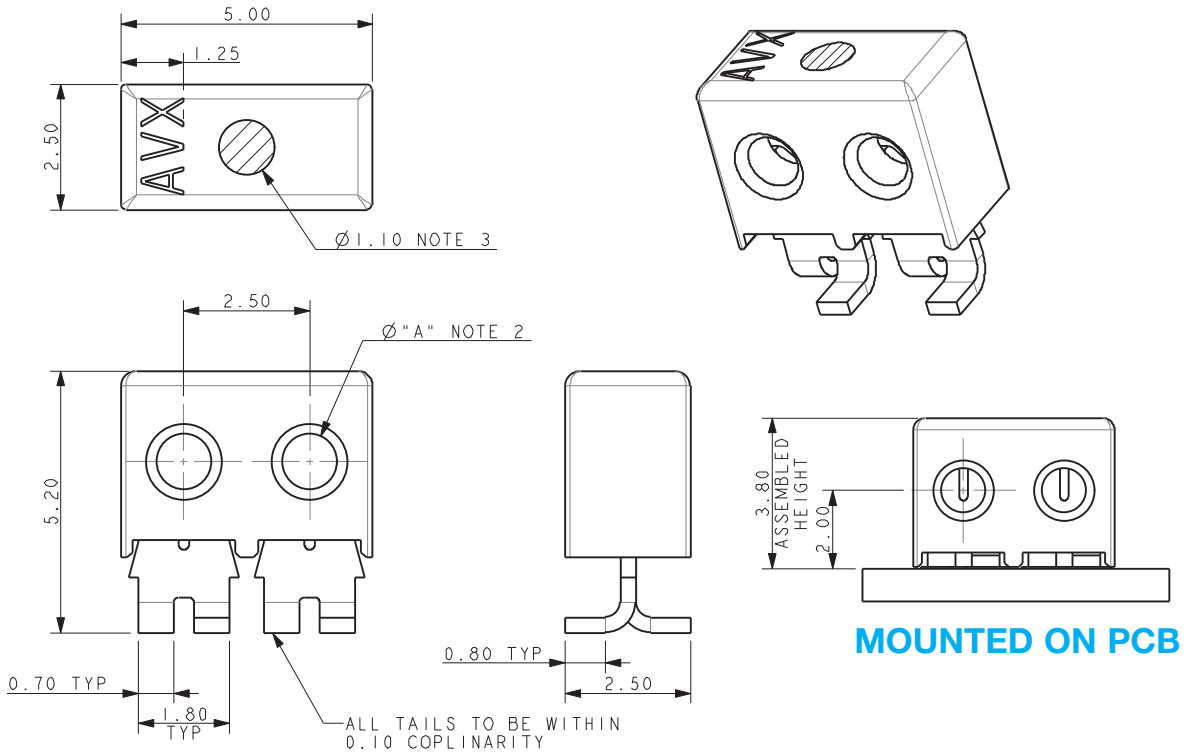

Code	Wire Gauge	Diameter A
701	28AWG	1.10
702	26AWG	1.30

#### NOTES:

- 2 WAY CONNECTOR FOR IDC WIRE TO BOARD CONNECTION. PRE-ASSEMBLED THROUGH WIRE CAP.
- CONTACT/CAP TO MATCH 26AWG AND 28AWG WIRES. SOLID OR STRANDED CONDUCTOR. MAXIMUM INSULATOR 1.00 MM DIAMETER.
- FLAT FACE ON TOP OF CAP TO AID PICK AND PLACE ASSEMBLY.
- FOR FULL PRODUCT SPECIFICATION ON STANDARD CONNECTORS REFER TO ELCO SPEC 201-01-139. UL COMPONENTS REFER TO ELCO SPEC 201-01-139UL.
- ASSEMBLY PROCEDURE, REFER TO APPLICATION NOTES 201-01-140.
- GENERAL TOLERANCE  $\pm 0.20$  UNLESS STATED.
- PACKED IN TAPE AND REEL, QUANTITY PER REEL 1000.
- CONNECTOR OUTLINE.
- CONTACT MATERIAL: TIN PLATED COPPER ALLOY.
- INSULATOR MATERIAL: HIGH TEMPERATURE NYLON, GLASS FILLED, UL94 V-0. COLOR REFER TO PAGE 9.
- FOR UL CODES UL REFERENCE E90723 (US AND CANADA).

### PACKING DETAILS

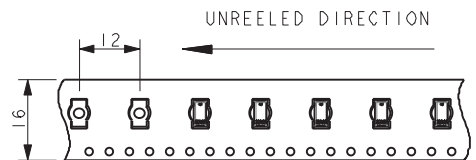
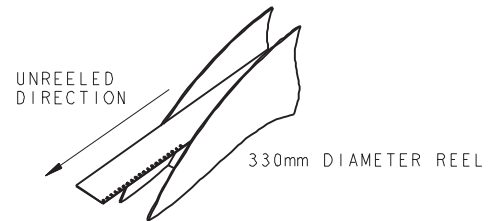

QUANTITY PER REEL 1000

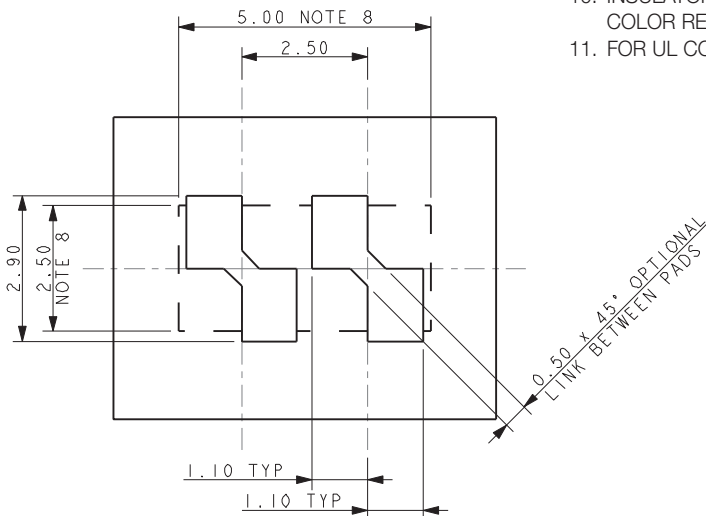

### SUGGEST PCB LAYOUT

### 26-28 AWG 3 WAY IDC CONNECTOR THROUGH WIRE CAPPED IDC

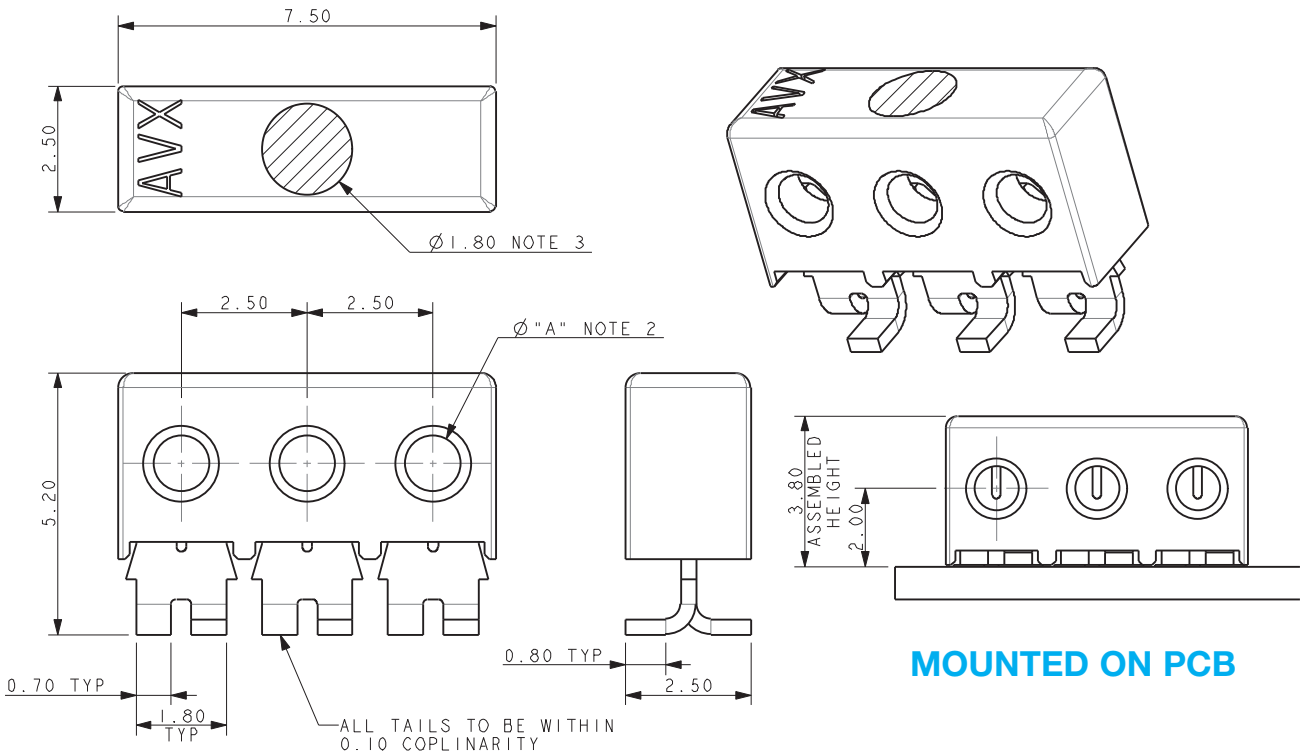

**MOUNTED ON PCB**

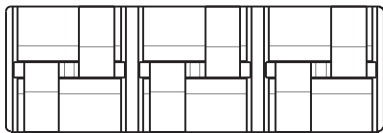

Code	Wire Gauge	Diameter A
701	28AWG	1.10
702	26AWG	1.30

**NOTES:**

- 3 WAY CONNECTOR FOR IDC WIRE TO BOARD CONNECTION. PRE-ASSEMBLED THROUGH WIRE CAP.
- CONTACT/CAP TO MATCH 26AWG AND 28AWG WIRES. SOLID OR STRANDED CONDUCTOR. MAXIMUM INSULATOR 1.00 MM DIAMETER.
- FLAT FACE ON TOP OF CAP TO AID PICK AND PLACE ASSEMBLY.
- FOR FULL PRODUCT SPECIFICATION ON STANDARD CONNECTORS REFER TO ELCO SPEC 201-01-139. UL COMPONENTS REFER TO ELCO SPEC 201-01-139UL.
- ASSEMBLY PROCEDURE, REFER TO APPLICATION NOTES 201-01-140.
- GENERAL TOLERANCE  $\pm 0.20$  UNLESS STATED.
- PACKED IN TAPE AND REEL, QUANTITY PER REEL 1000.
- CONNECTOR OUTLINE.
- CONTACT MATERIAL: TIN PLATED COPPER ALLOY.
- INSULATOR MATERIAL: HIGH TEMPERATURE NYLON, GLASS FILLED, UL94 V-0. COLOR REFER TO PAGE 9.
- FOR UL CODES UL REFERENCE E90723 (US AND CANADA).

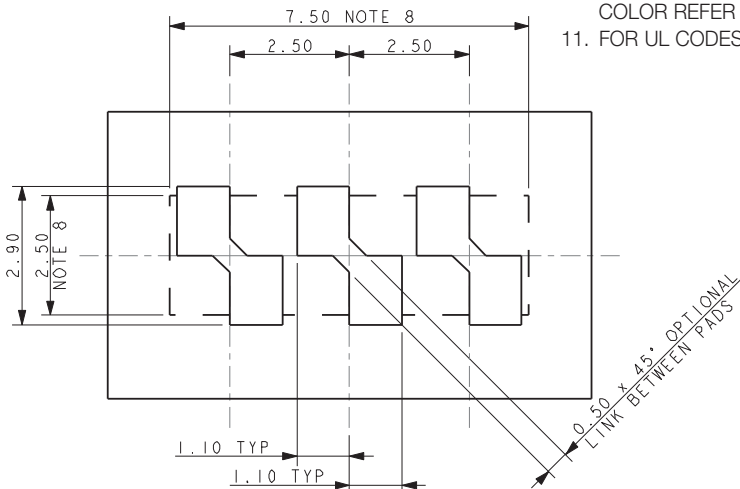

**SUGGEST PCB LAYOUT**

### PACKING DETAILS

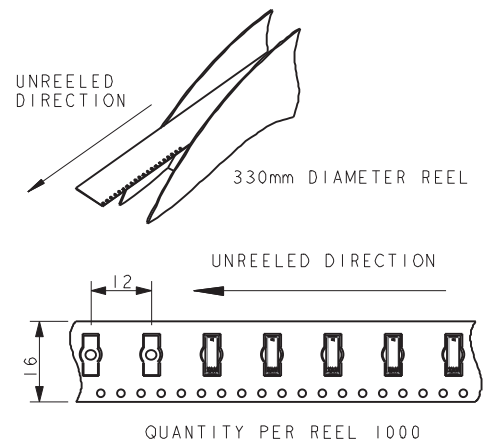

### 26-28 AWG 2 WAY IDC CONNECTOR WIRE STOP CAPPED IDC

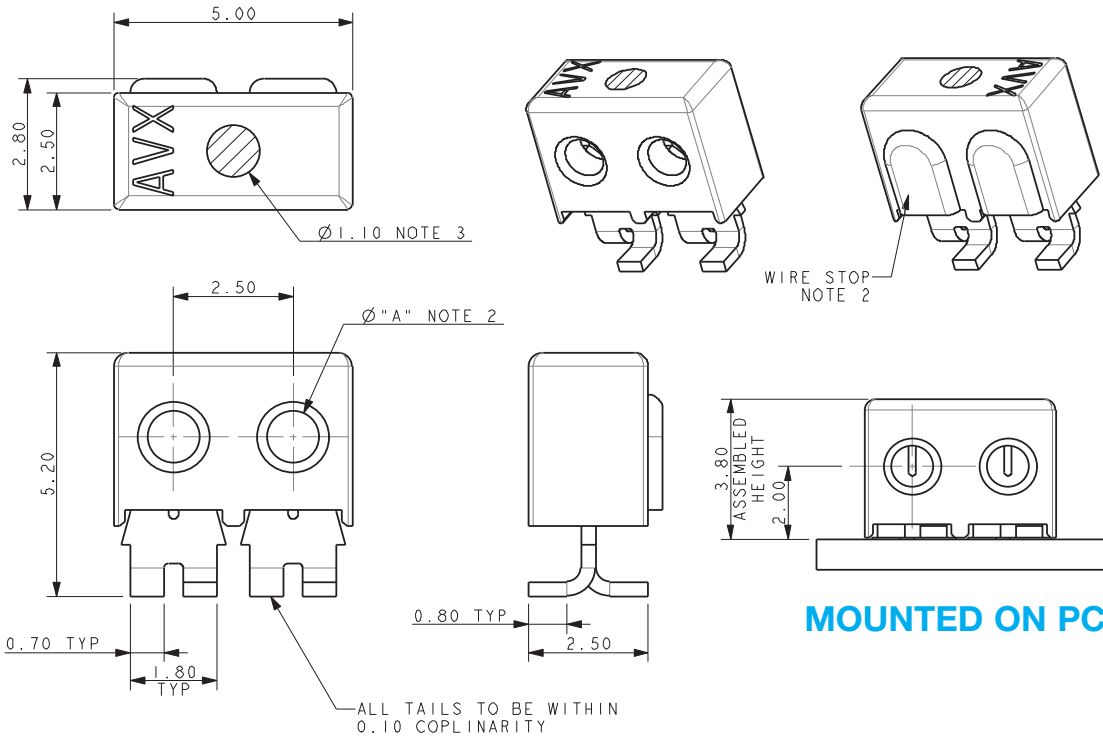

**MOUNTED ON PCB**

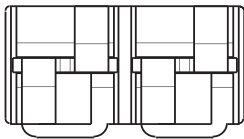

Code	Wire Gauge	Diameter A
701	28AWG	1.10
702	26AWG	1.30

**NOTES:**

- 2 WAY CONNECTOR FOR IDC WIRE TO BOARD CONNECTION. PRE-ASSEMBLED WIRE STOP CAP.
- WIRE STOP CAP PROTECTS END OF WIRE.
- CONTACT/CAP TO MATCH 26AWG AND 28AWG WIRES. SOLID OR STRANDED CONDUCTOR. MAXIMUM INSULATOR 1.00 MM DIAMETER.
- FLAT FACE ON TOP OF CAP TO AID PICK AND PLACE ASSEMBLY.
- FOR FULL PRODUCT SPECIFICATION ON STANDARD CONNECTORS REFER TO ELCO SPEC 201-01-139. UL COMPONENTS REFER TO ELCO SPEC 201-01-139UL.
- ASSEMBLY PROCEDURE, REFER TO APPLICATION NOTES 201-01-140.
- GENERAL TOLERANCE  $\pm 0.20$  UNLESS STATED.
- PACKED IN TAPE AND REEL, QUANTITY PER REEL 1000.
- CONNECTOR OUTLINE.
- CONTACT MATERIAL: TIN PLATED COPPER ALLOY.
- INSULATOR MATERIAL: HIGH TEMPERATURE NYLON, GLASS FILLED, UL94 V-0. COLOR REFER TO PAGE 9.
- FOR UL CODES UL REFERENCE E90723 (US AND CANADA).

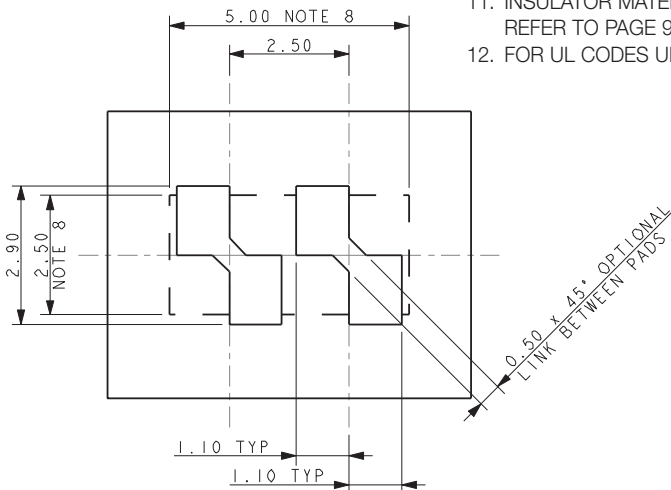

**SUGGEST PCB LAYOUT**

### PACKING DETAILS

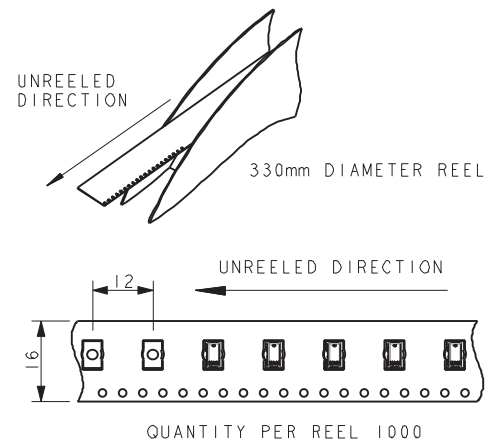

### 26-28 AWG 3 WAY IDC CONNECTOR WIRE STOP CAPPED IDC

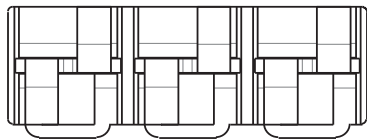
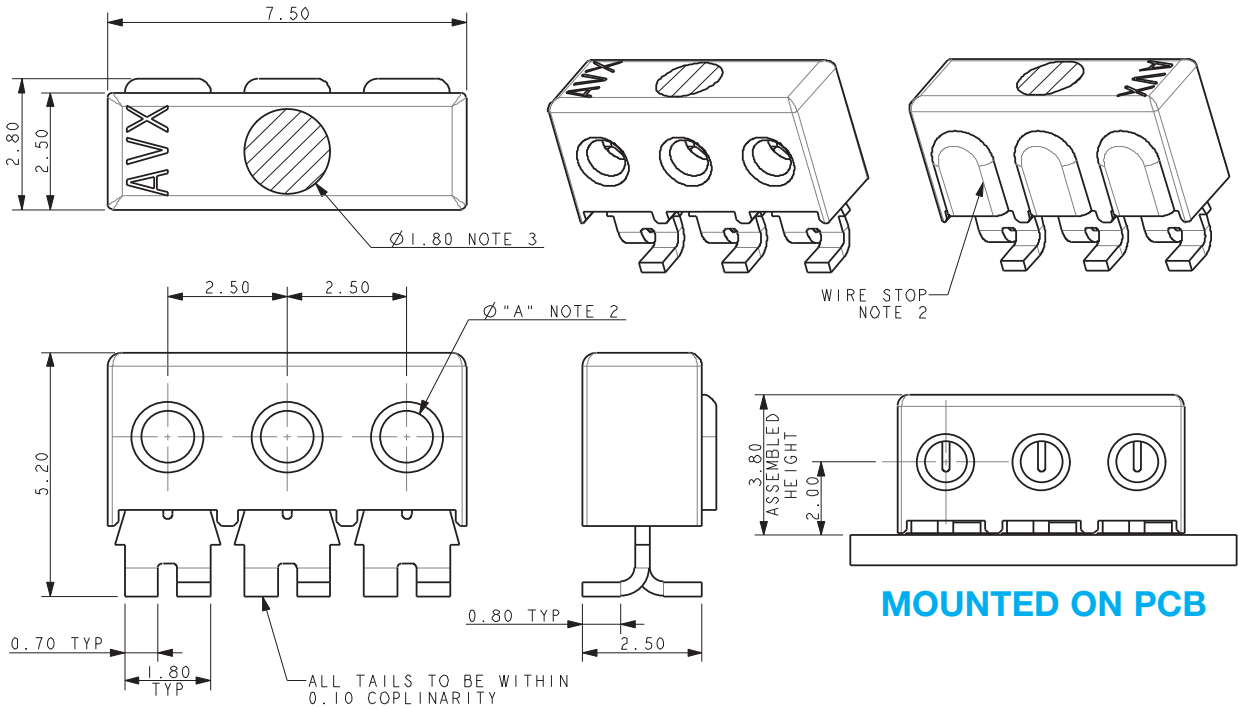

Code	Wire Gauge	Diameter A
701	28AWG	1.10
702	26AWG	1.30

#### NOTES:

- 3 WAY CONNECTOR FOR IDC WIRE TO BOARD CONNECTION. PRE-ASSEMBLED WIRE STOP CAP.
- WIRE STOP CAP PROTECTS END OF WIRE.
- CONTACT/CAP TO MATCH 26AWG AND 28AWG WIRES. SOLID OR STRANDED CONDUCTOR. MAXIMUM INSULATOR 1.00 MM DIAMETER.
- FLAT FACE ON TOP OF CAP TO AID PICK AND PLACE ASSEMBLY.
- FOR FULL PRODUCT SPECIFICATION ON STANDARD CONNECTORS REFER TO ELCO SPEC 201-01-139. UL COMPONENTS REFER TO ELCO SPEC 201-01-139UL.
- ASSEMBLY PROCEDURE, REFER TO APPLICATION NOTES 201-01-140.
- GENERAL TOLERANCE  $\pm 0.20$  UNLESS STATED.
- PACKED IN TAPE AND REEL, QUANTITY PER REEL 1000.
- CONNECTOR OUTLINE.
- CONTACT MATERIAL: TIN PLATED COPPER ALLOY.
- INSULATOR MATERIAL: HIGH TEMPERATURE NYLON, GLASS FILLED, UL94 V-0. COLOR REFER TO PAGE 9.
- FOR UL CODES UL REFERENCE E90723 (US AND CANADA).

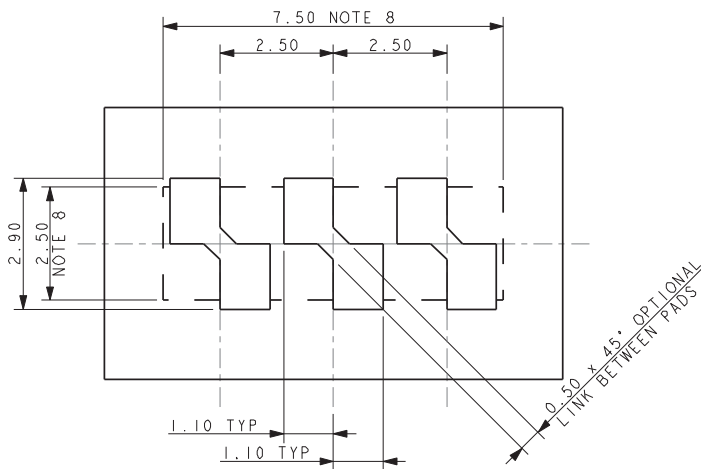

#### SUGGEST PCB LAYOUT

#### PACKING DETAILS

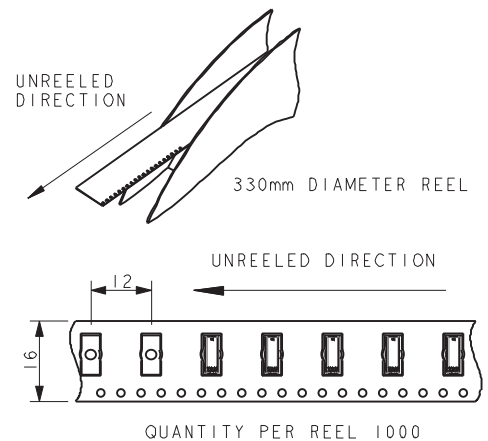

### 26-28 AWG ASSEMBLED CAPPED IDC CONNECTORS

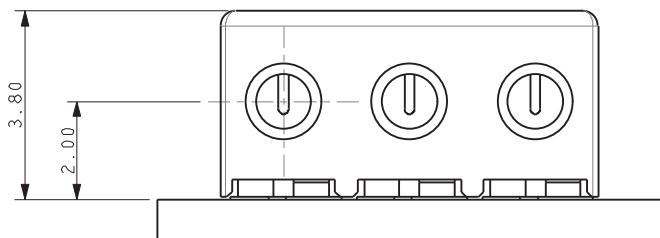

MOUNTED ON PCB

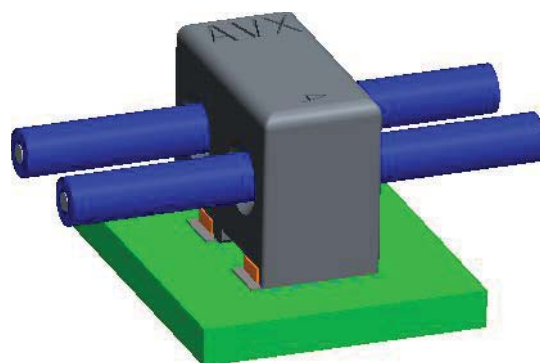
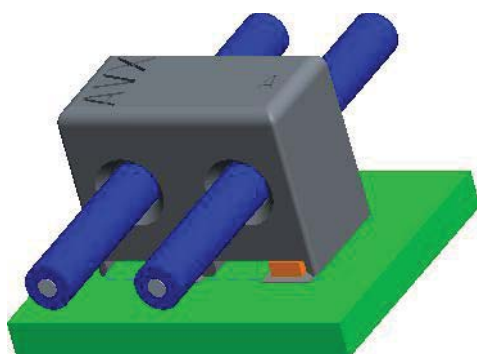

TYPICAL THROUGH WIRE ASSEMBLY

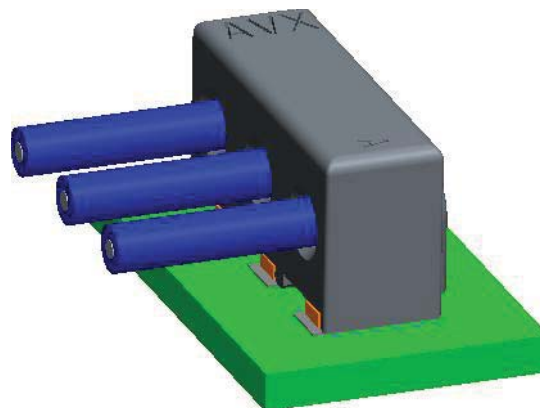
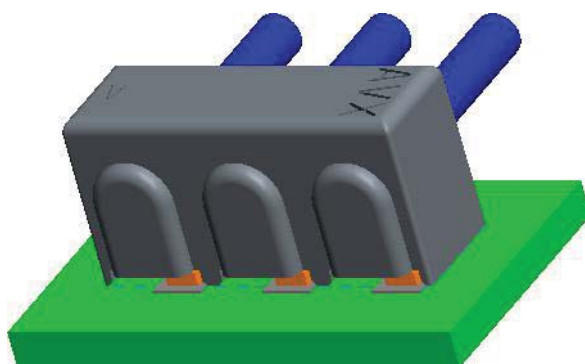

TYPICAL WIRE STOP ASSEMBLY



# Standard IDC 18-24 AWG: WTB

00-9176

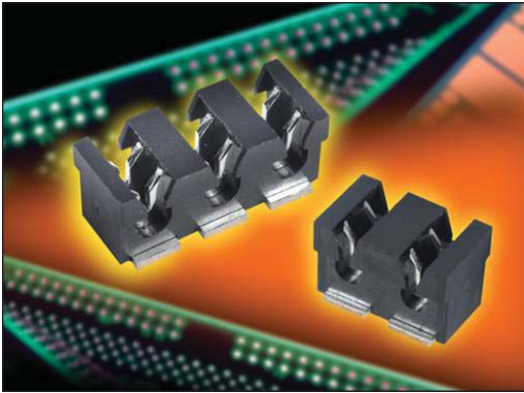

The 917X series of surface mount Insulation Displacement Connectors (IDC) were developed to meet the harsh automotive and industrial market applications for connecting individual wires directly to a PCB ranging from 14 AWG to 28 AWG. This industry proven contact system has been tested to automotive levels of shock, vibration, and temperature cycling to prove their reliability and robustness. The simplicity of inserting a wire into the connector with a small tool allows a wide range of devices to be connected to the PCB without soldering. In SSL applications specifically, these connectors are used to bring power and signal onto the PCB or are used to daisy chain multiple boards together in a long string. While the IDC contact provides a gas-tight connection to conductor of the wire, the housing has been designed to grab the insulation of the wire to provide a positive strain relief even in the harshest conditions. In case of repair, the wires can be removed and replace up to three times.

The 9176 series accepts 18 AWG to 24 AWG wires with an insulation diameter ranging from 1.1mm to 2.1mm. These dual contact connectors support a 10 amp current rating with two large SMT solder tails per wire to provide maximum stability on the PCB. Available in 1p-3p configuration, these connectors can be end stackable for higher pin counts. The 9176 series also comes with optional locking strain relief caps that act as the termination tool for severe vibration applications.

## APPLICATIONS

- Connecting discrete wire components directly to the PCB
- Bringing power and signals onto a PCB
- Daisy chaining PCB's together to create a continuous string of boards
- Application Notes: refer to 201-01-124

## FEATURES AND BENEFITS

- IDC contact provides a gas-tight connection to the PCB for long term reliability
- Connector housing captures the wire insulation for positive strain relief
- Tested to automotive levels on shock, vibration and temperature cycling for reliability
- Low and high volume assembly tools to match production volumes
- Reduced total applied cost versus solder or crimp processes
- Optional thru and end caps lock in place to provide maximum strain relief
- High temperature insulator capable to 260°C reflow soldering processes

## ELECTRICAL

- Current Rating: 10 Amp / Contact
- Voltage Rating: 300 VAC

## ENVIRONMENTAL

- Operating Temperature: -40°C to +125°C

## MECHANICAL

- Insulator Material: Nylon 46: UL94V0
- Contact Material: Phosphor Bronze
- Plating: Tin over Nickel
- Durability: 3 Cycles

## HOW TO ORDER

**00**  
Prefix

**9176**  
Series

**00X**  
Number of Ways

Code	No of Ways	Details
001	1	Page 17
002	2	Page 18
003	3	Page 19

**OXX**  
Wire Gauge Size

Code	Accepted Wire Gauge	Wire Insulation	Cap Code Pages 20-21
001	18 Gauge Stranded	Ø 1.6-2.1	021
011	20 Gauge Solid or Stranded	Ø 1.6-2.1	021
022	22 Gauge Solid or Stranded	Ø 1.1-1.6	016
032	24 Gauge Solid or Stranded	Ø 1.1-1.6	016

**X**  
Insulator Color  
9 = UL White  
8 = UL Black  
Special Order

**06**  
Plating Option  
06 = Pure Tin all over



Certification: UL File #E90723



### CONNECTOR/TOOLING PART NUMBER MATRIX

SERIES 9176 IDC					HAND INSERTION TOOLING*			ACCESSORY CAPS	
AWG	Wire Insulation	Positions	Color	Part Number	Plastic (medium volume)	Metal (high volume)	Mass Termination	Through Wire	Wire Stop
18	Ø 1.6 - 2.1	1p	Black	009176001001806	069176701601000	069176701701000	N/A	609176001021000	609176001021099
18	Ø 1.6 - 2.1	1p	White	009176001001906	069176701601000	069176701701000	N/A	609176001021100	609176001021199
18	Ø 1.6 - 2.1	2p	Black	009176002001806	069176701601000	069176701701000	069176701701002	609176002021000	609176002021099
18	Ø 1.6 - 2.1	2p	White	009176002001906	069176701601000	069176701701000	069176701701002	609176002021100	609176002021199
18	Ø 1.6 - 2.1	3p	Black	009176003001806	069176701601000	069176701701000	069176701701003	609176003021000	609176003021099
18	Ø 1.6 - 2.1	3p	White	009176003001906	069176701601000	069176701701000	069176701701003	609176003021100	609176003021199
20	Ø 1.6 - 2.1	1p	Black	009176001011806	069176701601000	069176701701000	N/A	609176001021000	609176001021099
20	Ø 1.6 - 2.1	1p	White	009176001011906	069176701601000	069176701701000	N/A	609176001021100	609176001021199
20	Ø 1.6 - 2.1	2p	Black	009176002011806	069176701601000	069176701701000	069176701701002	609176002021000	609176002021099
20	Ø 1.6 - 2.1	2p	White	009176002011906	069176701601000	069176701701000	069176701701002	609176002021100	609176002021199
20	Ø 1.6 - 2.1	3p	Black	009176003011806	069176701601000	069176701701000	069176701701003	609176003021000	609176003021099
20	Ø 1.6 - 2.1	3p	White	009176003011906	069176701601000	069176701701000	069176701701003	609176003021100	609176003021199
22	Ø 1.1 - 1.6	1p	Black	009176001022806	069176701602000	069176701702000	N/A	609176001016000	609176001016099
22	Ø 1.1 - 1.6	1p	White	009176001022906	069176701602000	069176701702000	N/A	609176001016100	609176001016199
22	Ø 1.1 - 1.6	2p	Black	009176002022806	069176701602000	069176701702000	069176701702002	609176002016000	609176002016099
22	Ø 1.1 - 1.6	2p	White	009176002022906	069176701602000	069176701702000	069176701702002	609176002016100	609176002016199
22	Ø 1.1 - 1.6	3p	Black	009176003022806	069176701602000	069176701702000	069176701702003	609176003016000	609176003016099
22	Ø 1.1 - 1.6	3p	White	009176003022906	069176701602000	069176701702000	069176701702003	609176003016100	609176003016199
24	Ø 1.1 - 1.6	1p	White	009176001032106	069176701602000	069176701702000	N/A	609176001016100	609176001016199
24	Ø 1.1 - 1.6	1p	Black	009176001032806	069176701602000	069176701702000	N/A	609176001016000	609176001016099
24	Ø 1.1 - 1.6	1p	White	009176001032906	069176701602000	069176701702000	N/A	609176001016100	609176001016199
24	Ø 1.1 - 1.6	2p	Black	009176002032806	069176701602000	069176701702000	069176701702002	609176002016000	609176002016099
24	Ø 1.1 - 1.6	2p	White	009176002032906	069176701602000	069176701702000	069176701702002	609176002016100	609176002016199
24	Ø 1.1 - 1.6	3p	Black	009176003032806	069176701602000	069176701702000	069176701702003	609176003016000	609176003016099
24	Ø 1.1 - 1.6	3p	White	009176003032906	069176701602000	069176701702000	069176701702003	609176003016100	609176003016199

\* Hand Insertion Tooling - Universal Hand Tool 067000773001000; Consult Application Notes 201-01-124

### 18-24 AWG 1 WAY IDC CONNECTOR

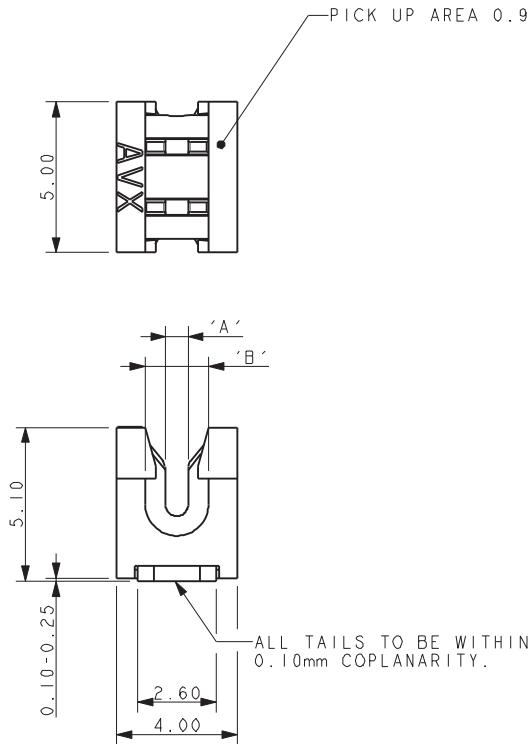

**NOTES:**

- CONNECTOR FOR IDC WIRE TO BOARD CONNECTION.
- CONTACT MATERIAL: PHOSPHOR BRONZE.  
INSULATION MATERIAL: HIGH TEMPERATURE NYLON 46.  
COLOR REFER TO PAGE 15.
- CONTACTS DESIGNED TO ACCEPT BETWEEN 20AWG AND 24AWG SOLID AND STRANDED WIRES. 18AWG WILL ONLY ACCEPT STRANDED WIRES, SEE TABLE.
- ALL DIMENSIONS FOR REFERENCE UNLESS OTHERWISE STATED.
- FOR FULL PRODUCT SPECIFICATION ON STANDARD CONNECTORS REFER TO ELCO SPEC 201-01-106
- APPLICATION NOTES 201-01-124.
- FOR PCB SPACE RESTRICTED BY WIRE ASSEMBLY TOOLING REFER TO PAGE 22.
- FOR HAND WIRE ASSEMBLY TOOLING REFER TO PAGE 22.
- FOR UL PRODUCT CODES UL REFERENCE E90723 (US AND CANADA).
- ALL DIMENSIONS ±0.20 TOLERANCE SPECIFIED.

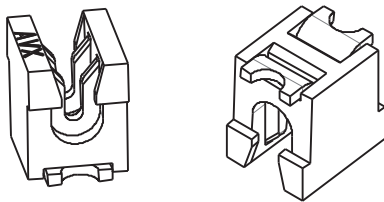
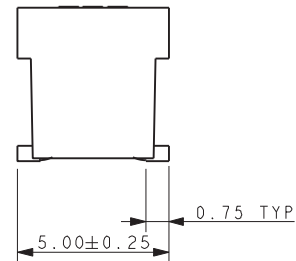

Code	Accepted Wire Gauge	A	Wire Insulation	B
001	18AWG Stranded	0.72	Ø 1.6-2.1	2.1
011	20AWG Solid and Stranded	0.60	Ø 1.6-2.1	2.1
022	22AWG Solid and Stranded	0.47	Ø 1.1-1.6	1.6
032	24AWG Solid and Stranded	0.37	Ø 1.1-1.6	1.6

### SMT PCB LAYOUT

PURE TIN PADS

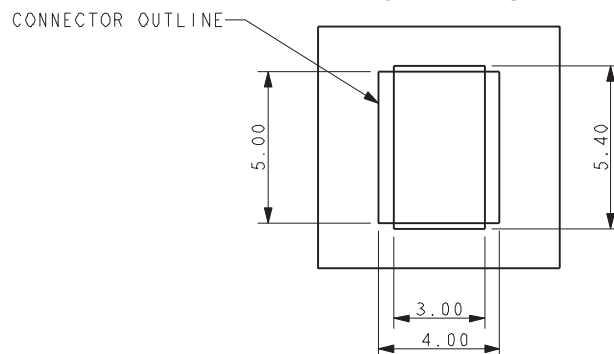

### PACKING DETAILS

REEL QTY	1000
LEADER	480MM
TRAILER	120MM

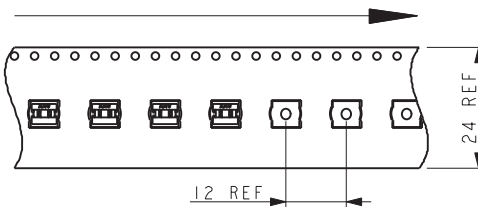
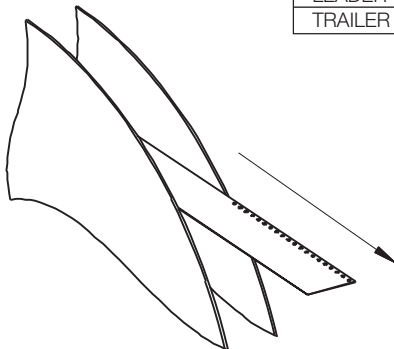

### 18-24 AWG 2 WAY IDC CONNECTOR

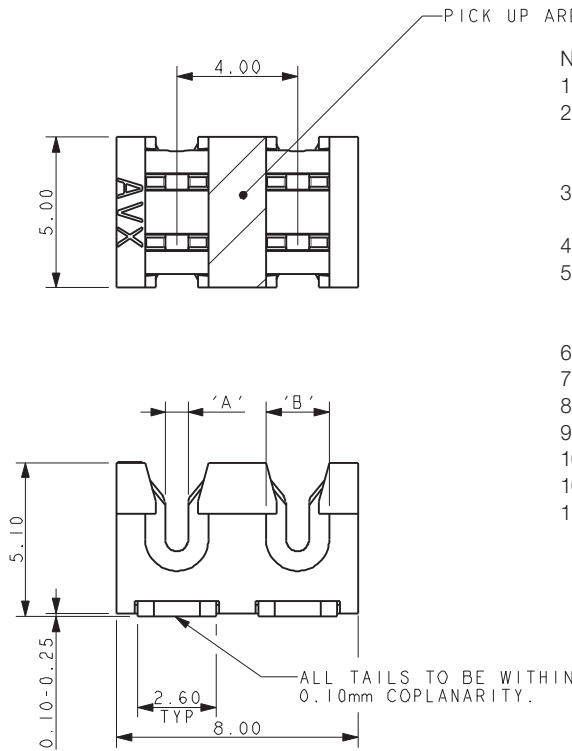

PICK UP AREA 1.9 x 5.00mm MIN

**NOTES:**

1. CONNECTOR FOR IDC WIRE TO BOARD CONNECTION.
2. CONTACT MATERIAL: PHOSPHOR BRONZE.  
INSULATION MATERIAL: HIGH TEMPERATURE NYLON 46.  
COLOR REFER TO PAGE 15.
3. CONTACTS DESIGNED TO ACCEPT BETWEEN 20AWG AND 24AWG SOLID AND STRANDED WIRES. 18AWG WILL ONLY ACCEPT STRANDED WIRES, SEE TABLE.
4. ALL DIMENSIONS FOR REFERENCE UNLESS OTHERWISE STATED.
5. FOR FULL PRODUCT SPECIFICATION ON STANDARD CONNECTORS REFER TO ELCO SPEC 201-01-106. UL COMPONENTS REFER TO ELCO SPECIFICATION 201-01-106UL.
6. APPLICATION NOTES 201-01-124.
7. FOR PCB SPACE RESTRICTED BY WIRE ASSEMBLY TOOLING REFER TO PAGE 22.
8. FOR HAND WIRE ASSEMBLY TOOLING REFER TO PAGE 22.
9. FOR PRESS WIRE ASSEMBLY TOOLING REFER TO PAGE 23
10. FOR ACCESSORY CAPS REFER TO PAGE 20 AND 21.
10. FOR UL PRODUCT CODES UL REFERENCE E90723 (US AND CANADA).
11. ALL DIMENSIONS ±0.20 TOLERANCE SPECIFIED.

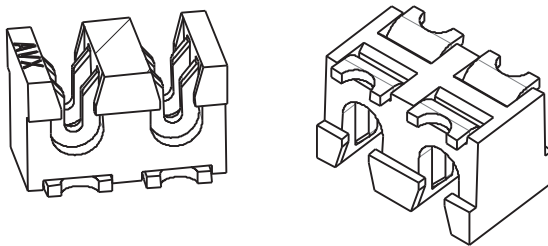
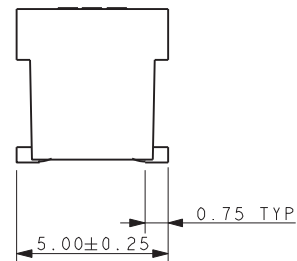

Code	Accepted Wire Gauge	A	Wire Insulation	B
001	18AWG Stranded	0.72	Ø 1.6-2.1	2.1
011	20AWG Solid and Stranded	0.60	Ø 1.6-2.1	2.1
022	22AWG Solid and Stranded	0.47	Ø 1.1-1.6	1.6
032	24AWG Solid and Stranded	0.37	Ø 1.1-1.6	1.6

### SMT PCB LAYOUT

PURE TIN PADS

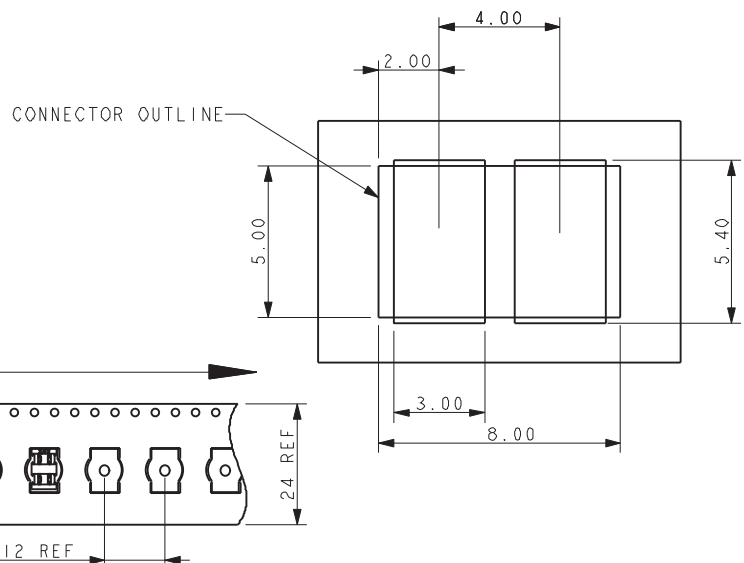

### PACKING DETAILS

REEL QTY	1000
LEADER	480MM
TRAILER	120MM

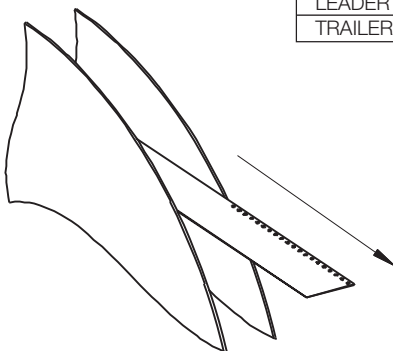

### 18-24 AWG 3 WAY IDC CONNECTOR

**NOTES:**

- CONNECTOR FOR IDC WIRE TO BOARD CONNECTION.
- CONTACT MATERIAL: PHOSPHOR BRONZE.  
INSULATION MATERIAL: HIGH TEMPERATURE NYLON 46.  
COLOR REFER TO PAGE 15.
- CONTACTS DESIGNED TO ACCEPT BETWEEN 20AWG AND 24AWG SOLID AND STRANDED WIRES. 18AWG WILL ONLY ACCEPT STRANDED WIRES, SEE TABLE.
- ALL DIMENSIONS FOR REFERENCE UNLESS OTHERWISE STATED.
- FOR FULL PRODUCT SPECIFICATION ON STANDARD CONNECTORS REFER TO ELCO SPEC 201-01-106. UL COMPONENTS REFER TO ELCO SPECIFICATION 201-01-106UL.
- APPLICATION NOTES 201-01-124.
- FOR PCB SPACE RESTRICTED BY WIRE ASSEMBLY TOOLING REFER TO PAGE 22.
- FOR HAND WIRE ASSEMBLY TOOLING REFER TO PAGE 22.
- FOR PRESS WIRE ASSEMBLY TOOLING REFER TO PAGE 23
- FOR ACCESSORY CAPS REFER TO PAGE 20 AND 21.
- FOR UL PRODUCT CODES UL REFERENCE E90723 (US AND CANADA).
- ALL DIMENSIONS  $\pm 0.20$  TOLERANCE SPECIFIED.

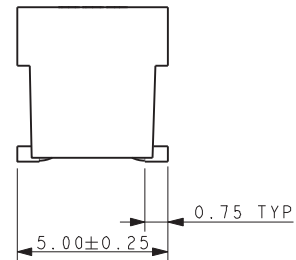
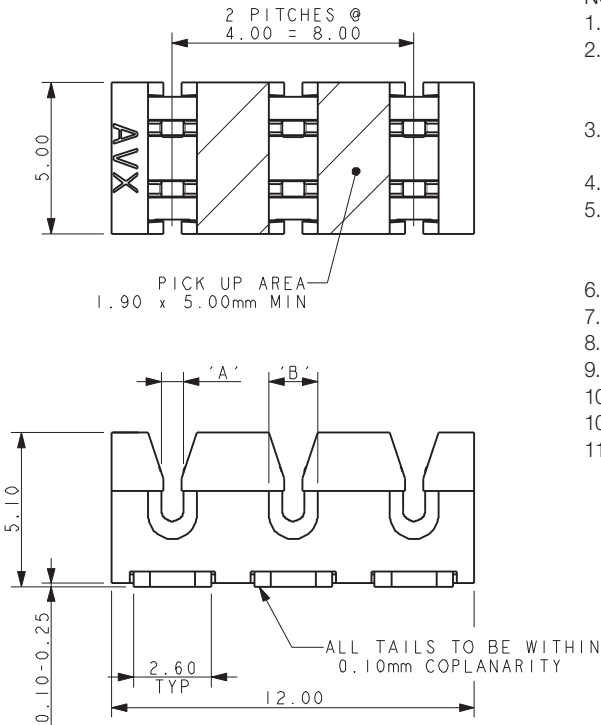

Code	Accepted Wire Gauge	A	Wire Insulation	B
001	18AWG Stranded	0.72	$\varnothing 1.6-2.1$	2.1
011	20AWG Solid and Stranded	0.60	$\varnothing 1.6-2.1$	2.1
022	22AWG Solid and Stranded	0.47	$\varnothing 1.1-1.6$	1.6
032	24AWG Solid and Stranded	0.37	$\varnothing 1.1-1.6$	1.6

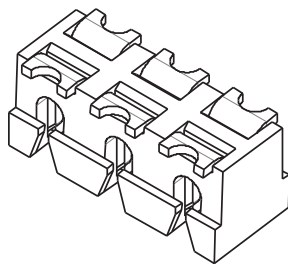
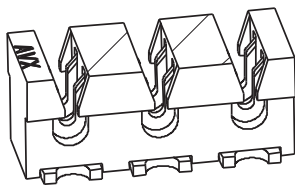

### SMT PCB LAYOUT

PURE TIN PADS

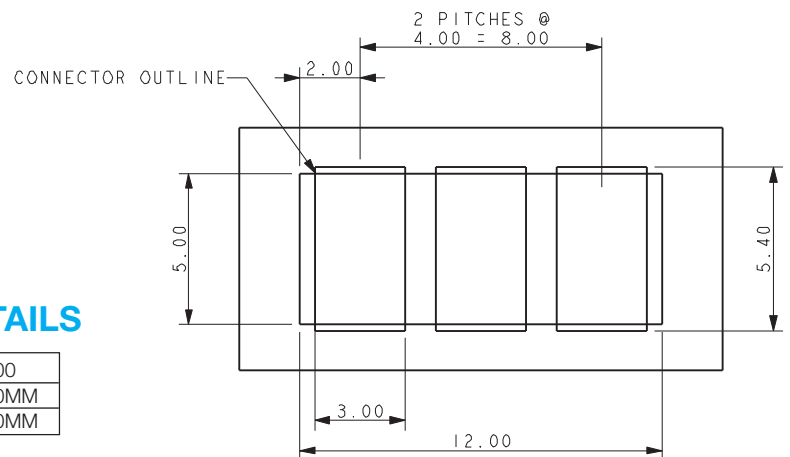

### PACKING DETAILS

REEL QTY	1000
LEADER	480MM
TRAILER	120MM

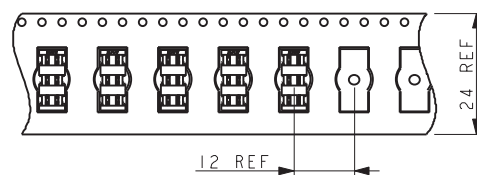
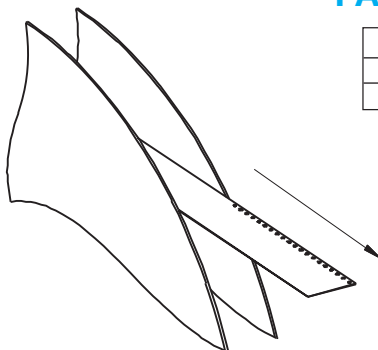

**60-9176-00X-0XX-X00**  
**ACCESSORY CAP – THROUGH WIRE**

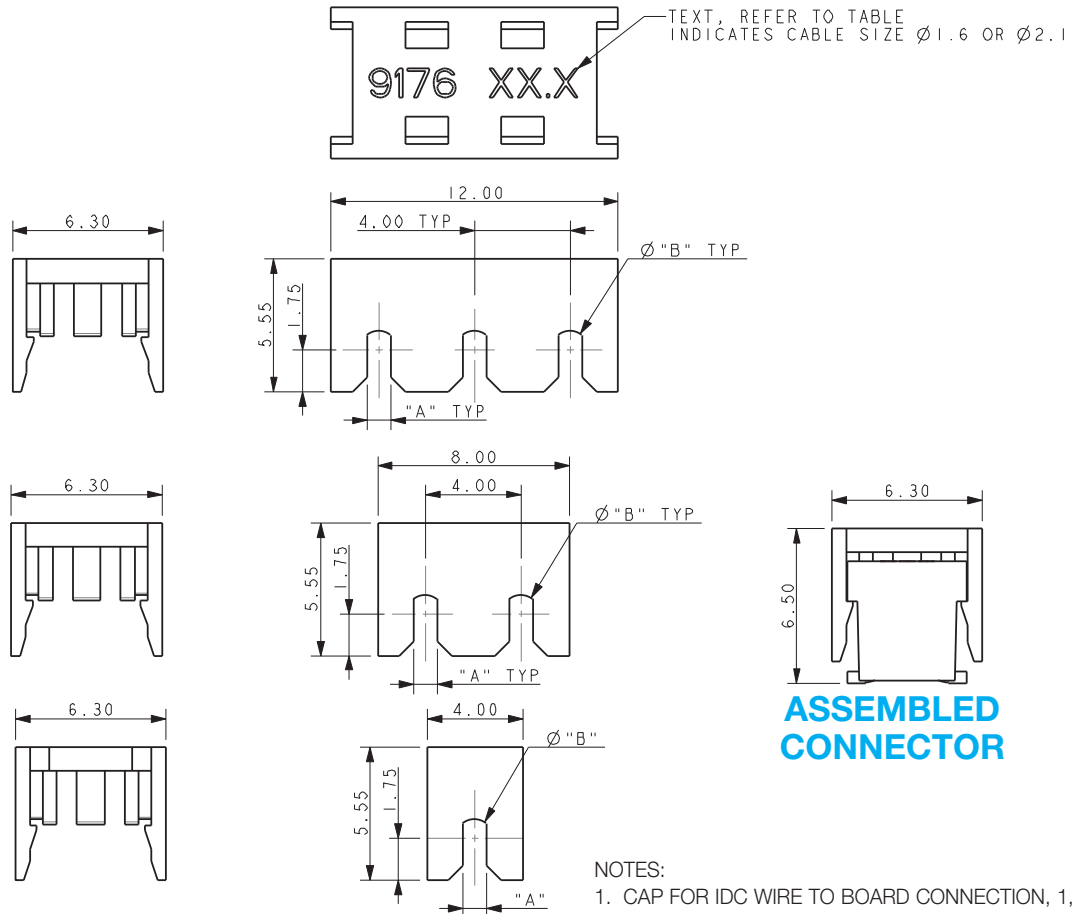

NOTES:

1. CAP FOR IDC WIRE TO BOARD CONNECTION, 1, 2 AND 3 WAY, THROUGH WIRE.
2. FOR USE WITH STANDARD 9176 IDC CONNECTORS, SEE PAGE 16 FOR THE CORRECT PART CODE TO MATCH WIRE.
3. CAP MATERIAL: GLASS FILLED NYLON 46, FOR COLORS SEE TABLE BELOW.
4. DIMENSIONS A, B AND TEXT, SEE TABLE BELOW.
5. CAPS DESIGNED TO ACCOMMODATE WIRE INSULATION DIAMETERS 1.1MM TO 1.6MM AND 1.6MM TO 2.1MM.
6. ALL DIMENSIONS SHOWN ARE REFERENCE DIMENSIONS.
7. PACKED IN BAGS, 1000 PIECES PER BAG.
8. ONE WAY CAP ASSEMBLY AID, REFER TO PAGE 24.
9. ALL DIMENSIONS  $\pm 0.20$  TOLERANCE SPECIFIED.

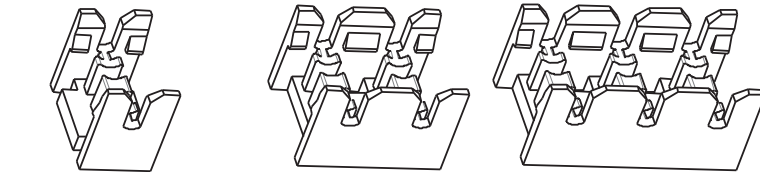

60-9176-001-016-X00    60-9176-002-016-X00    60-9176-003-016-X00

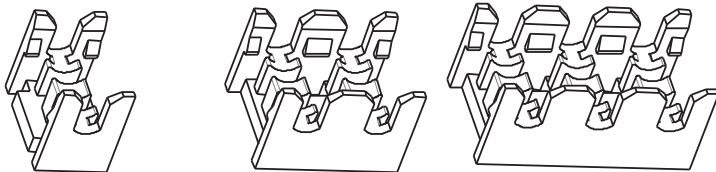

60-9176-001-021-X00    60-9176-002-021-X00    60-9176-003-021-X00

Code	Slot A	Diameter B	Text
016	1.00	1.60	$\varnothing 1.6$
021	1.50	2.10	$\varnothing 2.1$

Color	X00
Black	000
White	100

**60-9176-00X-0XX-X99**  
**ACCESSORY CAP - WIRE STOP**

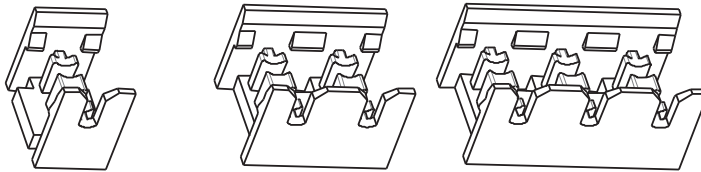
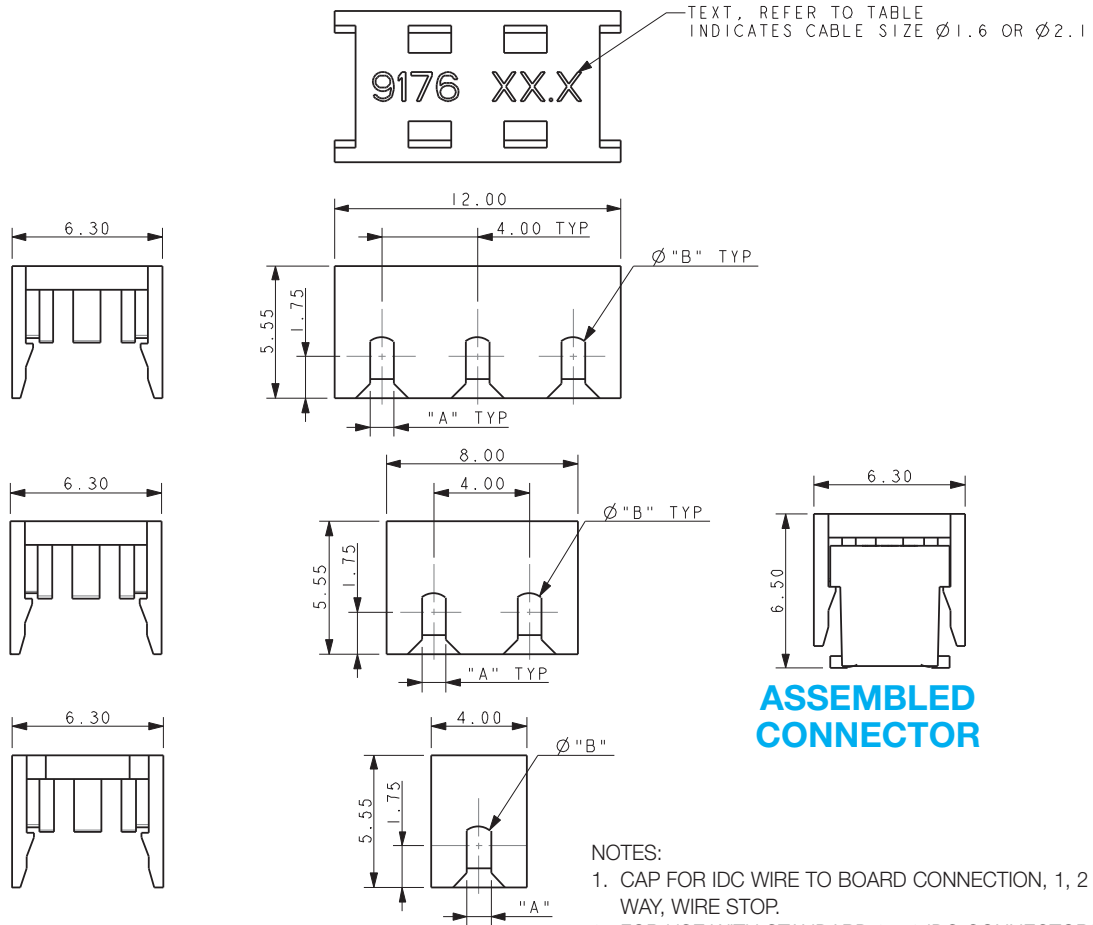

60-9176-001-016-X99    60-9176-002-016-X99    60-9176-003-016-X99

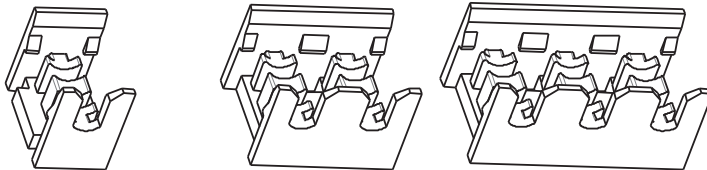

60-9176-001-021-X99    60-9176-002-021-X99    60-9176-003-021-X99

**NOTES:**

1. CAP FOR IDC WIRE TO BOARD CONNECTION, 1, 2 AND 3 WAY, WIRE STOP.
2. FOR USE WITH STANDARD 9176 IDC CONNECTORS, SEE PAGE 16 FOR THE CORRECT PART CODE TO MATCH WIRE.
3. CAP MATERIAL: GLASS FILLED NYLON 46, FOR COLORS SEE TABLE BELOW.
4. DIMENSIONS A, B AND TEXT, SEE TABLE BELOW.
5. CAPS DESIGNED TO ACCOMMODATE WIRE INSULATION DIAMETERS 1.1MM TO 1.6MM AND 1.6MM TO 2.1MM.
6. ALL DIMENSIONS SHOWN ARE REFERENCE DIMENSIONS.
7. PACKED IN BAGS, 1000 PIECES PER BAG.
8. ONE WAY CAP ASSEMBLY AID, REFER TO PAGE 24.
9. ALL DIMENSIONS  $\pm 0.20$  TOLERANCE SPECIFIED.

Code	Slot A	Diameter B	Text
016	1.00	1.60	$\varnothing 1.6$
021	1.50	2.10	$\varnothing 2.1$

Color	X00
Black	000
White	100

### HAND INSERTION TOOLING FOR SINGLE 18/24 GAUGE WIRE

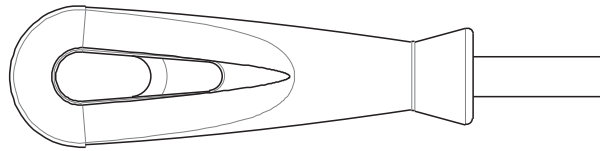

#### UNIVERSAL HANDLE

Details	Tool Part Number
6.35 A/F HEX BIT HOLDER	06 7000 7730 01 000

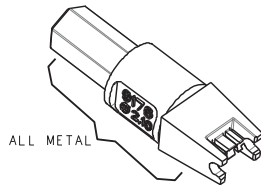

#### HIGH PRODUCTION Metal

Max Insulation Dia	Tool Part Number
Ø2.10	06 9176 7017 01 000
Ø1.60	06 9176 7017 02 000

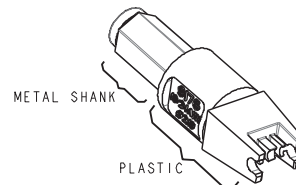

#### MEDIUM PRODUCTION Metal/Plastic

Max Insulation Dia	Tool Part Number
Ø2.10	06 9176 7016 01 000
Ø1.60	06 9176 7016 02 000

### CLEARANCE AREA ON PCB FOR HAND TOOLING

#### 1 WAY

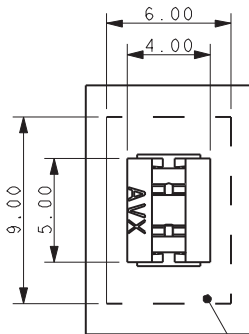

AREA TO BE KEPT CLEAR FOR TOOLING

#### 2 WAY

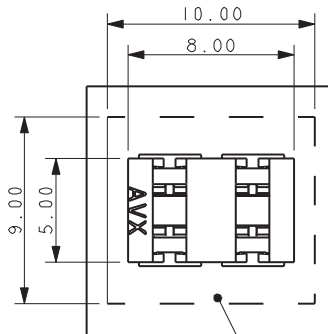

AREA TO BE KEPT CLEAR FOR TOOLING

#### 3 WAY

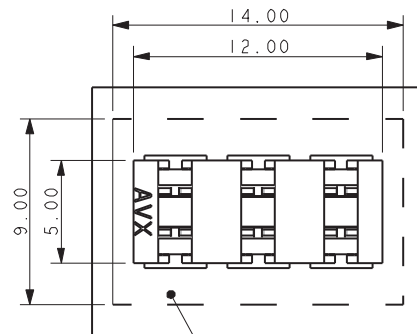

AREA TO BE KEPT CLEAR FOR TOOLING

**INSERTION TOOLING  
REQUIRES HAND PRESS WITH FLAT ROCK PLATES**

**2 WAY**

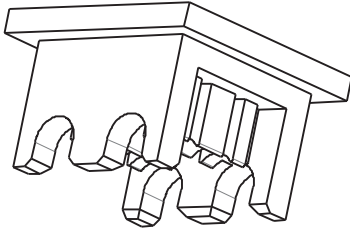

**3 WAY**

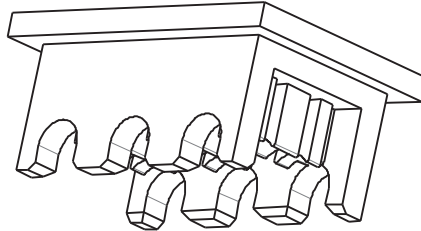

**HIGH PRODUCTION  
Metal**

No. of Ways	Max Insulation Dia	Tool Part Number
2	Ø2.10	06 9176 7017 01 002
	Ø1.60	06 9176 7017 02 002
3	Ø2.10	06 9176 7017 01 003
	Ø1.60	06 9176 7017 02 003

**PCB RESTRICTED AREAS FOR PRESS ASSEMBLY TOOLING**

**2 WAY**

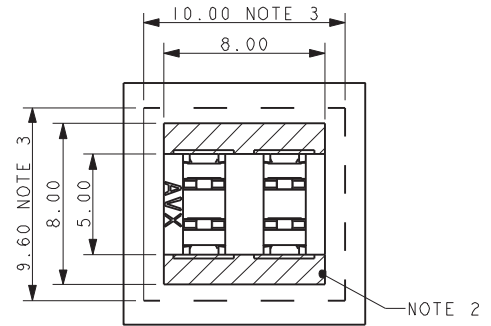
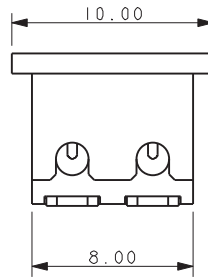
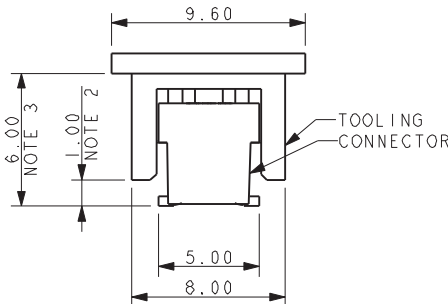

**3 WAY**

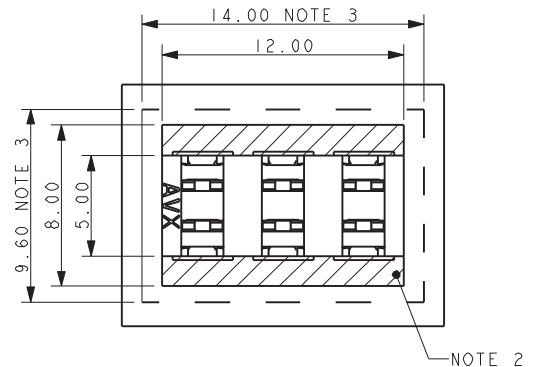
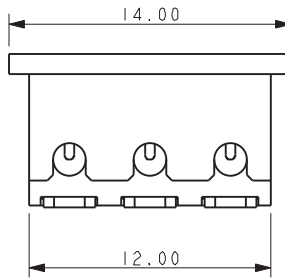
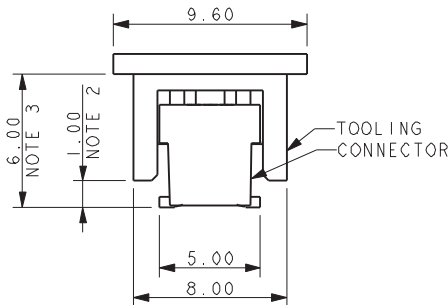

NOTES:

1. DIMENSIONS SHOWN ARE REFERENCE DIMENSIONS.
2. MAXIMUM COMPONENT HEIGHT 1.00MM IN THIS AREA.
3. MAXIMUM COMPONENT HEIGHT 6.00MM IN THIS AREA.
4. THE SAME RESTRICTIONS APPLY TO ALL WIRE INSULATION DIAMETERS.
5. 2 AND 3 WAY TOOLS ONLY, FOR USE UNDER HAND PRESS WITH FLAT PLATES.
6. FOR HAND TOOLING REFER TO PAGE 22.
7. ALL DIMENSIONS ±0.20 UNLESS TOLERANCE SPECIFIED.



**HAND INSERTION TOOLING  
FOR ONE WAY CAP INSERTION**

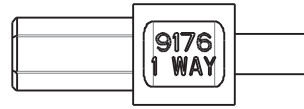
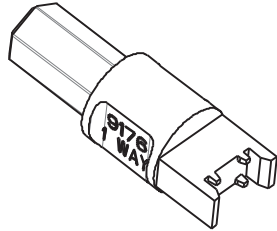

06-9176-7028-01-000

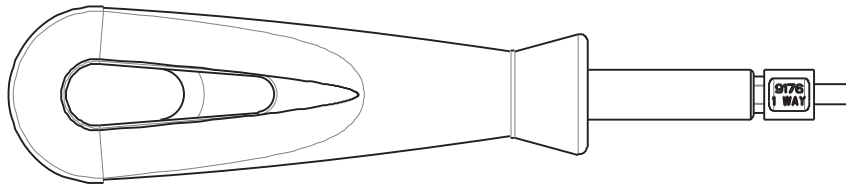

TO BE USED WITH 06-7000-7730-01-000  
UNIVERSAL HANDLE

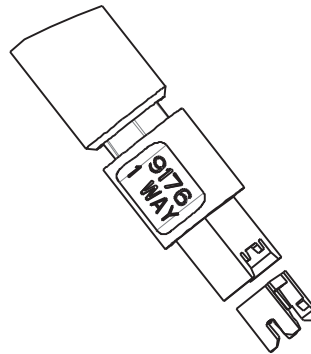

FOR ASSEMBLY INSTRUCTION REFER TO 201-01-124 APPLICATION NOTES

**CLEARANCE AREA ON PCB FOR HAND TOOLING**

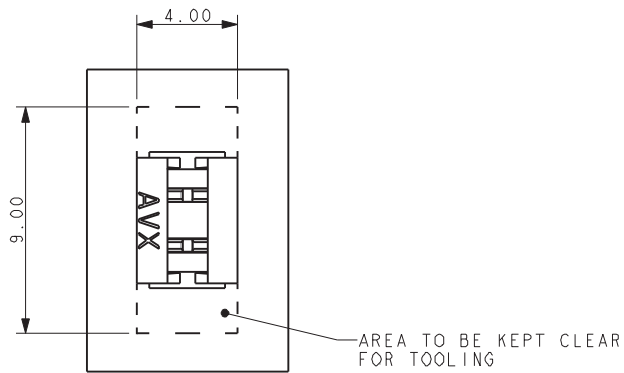

### ASSEMBLED CONNECTOR

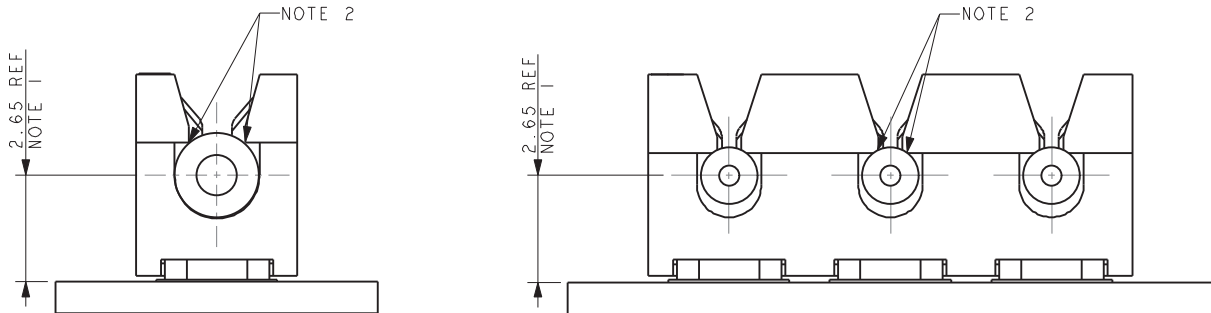

### STANDARD CONNECTOR

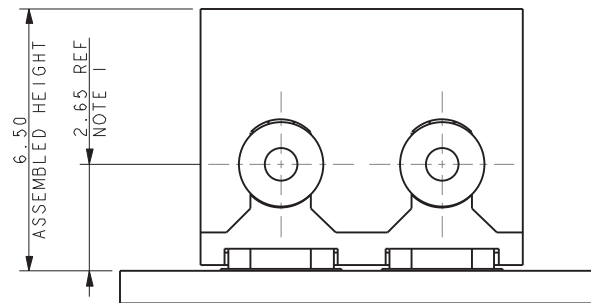

### CONNECTOR WITH CAP

NOTES:

1. ASSEMBLED HEIGHTS INCLUDE 0.10MM ALLOWANCE FOR PAD AND SOLDER THICKNESS.  
NO ALLOWANCE HAS BEEN MADE FOR ANY SOLDER RESIST OR OTHER FEATURES.
2. WHEN THE WIRE IS ASSEMBLED THE INSULATION SHOULD BE TRAPPED BY THESE EDGES.

# Capped 18-24 AWG: WTB

9176-700



The market and applications for simple and reliable discrete Wire-to-Board connectors continue to evolve. AVX first introduced the 9176 series of surface mountable Insulation Displacement Connectors (IDC) in 2007. Developed for harsh industrial and automotive applications, these connectors have been used in hundreds of applications from today's "Smart Meter" all the way down to a simple sensor termination to a PCB. Size and performance has been one of the key factors for selecting this connector in terminating 18-24AWG wires to a PCB.

The next generation of IDC connector moves beyond all of the technical and performance attributes to address the "User Friendliness" of the product. By changing the insulator from acting as a connector body and make it more like a contact carrier, the insulator becomes the wire location and insertion aid without any special tools. The wire is just inserted into the cap (no stripping required) and then pressed down to provide a secure "Gas Tight" termination. This configuration simplifies and cost reduces the entire wire termination process for connecting discrete wires to a PCB.

## APPLICATIONS

- Connecting discrete wire components to a PCB
- Bringing power and signals onto a PCB
- Daisy chaining PCB's together to create a continuous string
- Reference Product Specification 201-01-140

## FEATURES AND BENEFITS

- IDC contact provides a gas-tight connection to the PCB for long term reliability
- Plastic cap retains the contacts in position prior to automatic placement, then acts as the assembly tool to terminate the wires; no special tooling.
- Tested to automotive levels on shock, vibration and temperature cycling for reliability
- Identical contact and footprint pattern to the existing 9176 for full backward compatibility and functionality
- The IDC contact reduces the total applied cost versus solder or crimp processes
- Connectors are available in two configurations for maximum flexibility; End and Through Wire

## ELECTRICAL

- Current Rating: 10 Amps / Contact
- Voltage Rating: 300 VAC

## ENVIRONMENTAL

- Operating Temperature: -40°C to +125°C

## MECHANICAL

- Insulator Material: Nylon UL94VO
- Contact Material: Phosphor Bronze
- Plating: Tin over Nickel
- Durability 3 Cycles

## HOW TO ORDER

<b>00</b>	<b>9176</b>	<b>00X</b>	<b>7XX</b>	<b>X</b>	<b>X</b>	<b>6</b>																																							
Prefix	Series	Number of Ways	Wire Gauge Size Capped - IDC Connector	Insulator Color	Cap Options	Plating Option																																							
		<table border="1"> <thead> <tr> <th>Code</th> <th>No of Ways</th> <th>Details</th> </tr> </thead> <tbody> <tr> <td>001</td> <td>1</td> <td>Pages 25 &amp; 28</td> </tr> <tr> <td>002</td> <td>2</td> <td>Pages 26 &amp; 29</td> </tr> <tr> <td>003</td> <td>3</td> <td>Pages 27 &amp; 30</td> </tr> </tbody> </table>	Code	No of Ways	Details	001	1	Pages 25 & 28	002	2	Pages 26 & 29	003	3	Pages 27 & 30	<table border="1"> <thead> <tr> <th>Code</th> <th>Accepted Wire Gauge</th> <th>Wire Insulation</th> </tr> </thead> <tbody> <tr> <td>701</td> <td>18 AWG Stranded</td> <td>Ø 1.6 - 2.1</td> </tr> <tr> <td>711</td> <td>20 AWG Solid and Stranded</td> <td>Ø 1.6 - 2.1</td> </tr> <tr> <td>722</td> <td>22 AWG Solid and Stranded</td> <td>Ø 1.1 - 1.6</td> </tr> <tr> <td>732</td> <td>24 AWG Solid and Stranded</td> <td>Ø 1.1 - 1.6</td> </tr> </tbody> </table>	Code	Accepted Wire Gauge	Wire Insulation	701	18 AWG Stranded	Ø 1.6 - 2.1	711	20 AWG Solid and Stranded	Ø 1.6 - 2.1	722	22 AWG Solid and Stranded	Ø 1.1 - 1.6	732	24 AWG Solid and Stranded	Ø 1.1 - 1.6	9 = UL White 8 = UL Black Special Order	<table border="1"> <thead> <tr> <th>Code</th> <th>Cap Option</th> <th>Description</th> <th>Detail</th> </tr> </thead> <tbody> <tr> <td>0</td> <td>Through Wire</td> <td>Allows wire to be terminated at any point</td> <td>Pages 25 - 27</td> </tr> <tr> <td>9</td> <td>Wire Stop</td> <td>Terminates end of wire End Protected by stop face</td> <td>Pages 28 - 30</td> </tr> </tbody> </table>	Code	Cap Option	Description	Detail	0	Through Wire	Allows wire to be terminated at any point	Pages 25 - 27	9	Wire Stop	Terminates end of wire End Protected by stop face	Pages 28 - 30	6 = Pure Tin all over
Code	No of Ways	Details																																											
001	1	Pages 25 & 28																																											
002	2	Pages 26 & 29																																											
003	3	Pages 27 & 30																																											
Code	Accepted Wire Gauge	Wire Insulation																																											
701	18 AWG Stranded	Ø 1.6 - 2.1																																											
711	20 AWG Solid and Stranded	Ø 1.6 - 2.1																																											
722	22 AWG Solid and Stranded	Ø 1.1 - 1.6																																											
732	24 AWG Solid and Stranded	Ø 1.1 - 1.6																																											
Code	Cap Option	Description	Detail																																										
0	Through Wire	Allows wire to be terminated at any point	Pages 25 - 27																																										
9	Wire Stop	Terminates end of wire End Protected by stop face	Pages 28 - 30																																										



Certification: UL File #E90723

# Capped 18-24 AWG: WTB

## 9176-700

### 18 - 24 AWG 1 WAY IDC CONNECTOR THROUGH WIRE CAPPED IDC

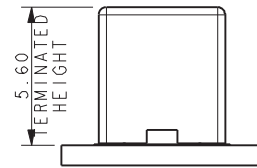
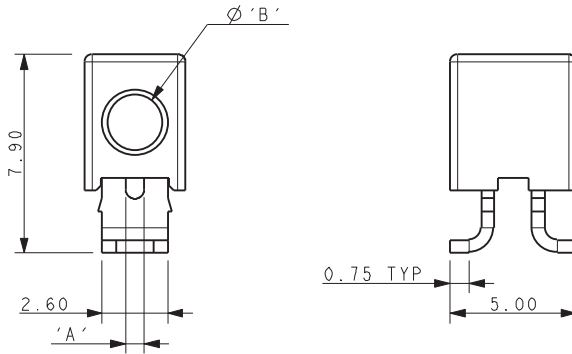
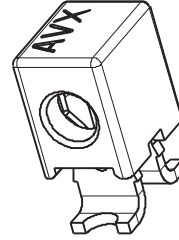
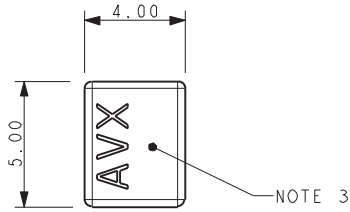

### MOUNTED ON PCB

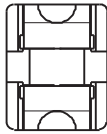

#### NOTES:

- 1 WAY CONNECTOR FOR IDC WIRE TO BOARD CONNECTION. PRE-ASSEMBLED THROUGH WIRE CAP.
- CONTACT/CAP TO MATCH 18-24 AWG STRANDED WIRE INSULATION DIAMETER RANGE AS IN TABLE.
- FLAT FACE ON TOP OF CAP TO AID PICK AND PLACE ASSEMBLY.
- FOR FULL DETAILS REFER TO ELCO SPECIFICATION 201-01-139.
- ASSEMBLY PROCEDURE, REFER TO APPLICATION NOTES 201-01-140.
- GENERAL TOLERANCE  $\pm 0.20$  UNLESS STATED.
- PACKED IN TAPE AND REEL, QUANTITY PER REEL 600.
- CONNECTOR OUTLINE.
- CONTACT MATERIAL: TIN PLATED COPPER ALLOY.
- INSULATOR MATERIAL: HIGH TEMPERATURE NYLON, GLASS FILLED, UL94 V-0. COLOR REFER TO PAGE 26.

Code	Accepted Wire Gauge	A	Wire Insulation	B
701	18 AWG Stranded	0.74	Ø 1.6-2.1	2.1
711	20 AWG Solid and Stranded	0.60	Ø 1.6-2.1	2.1
722	22 AWG Solid and Stranded	0.47	Ø 1.1-1.6	1.6
732	24 AWG Solid and Stranded	0.37	Ø 1.1-1.6	1.6

### PACKING DETAILS

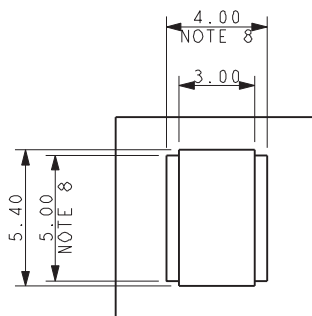

### SUGGEST PCB LAYOUT

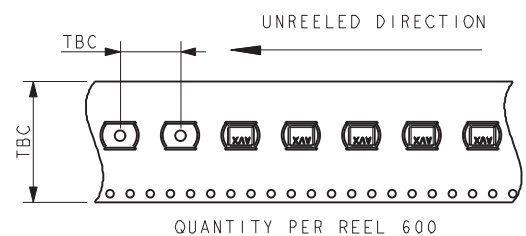
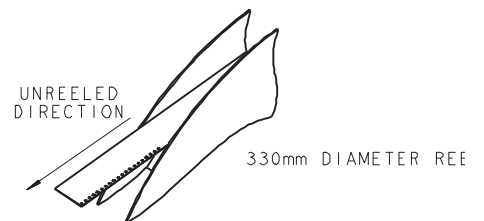

# Capped 18-24 AWG: WTB

## 9176-700

### 18 - 24 AWG 2 WAY IDC CONNECTOR THROUGH WIRE CAPPED IDC

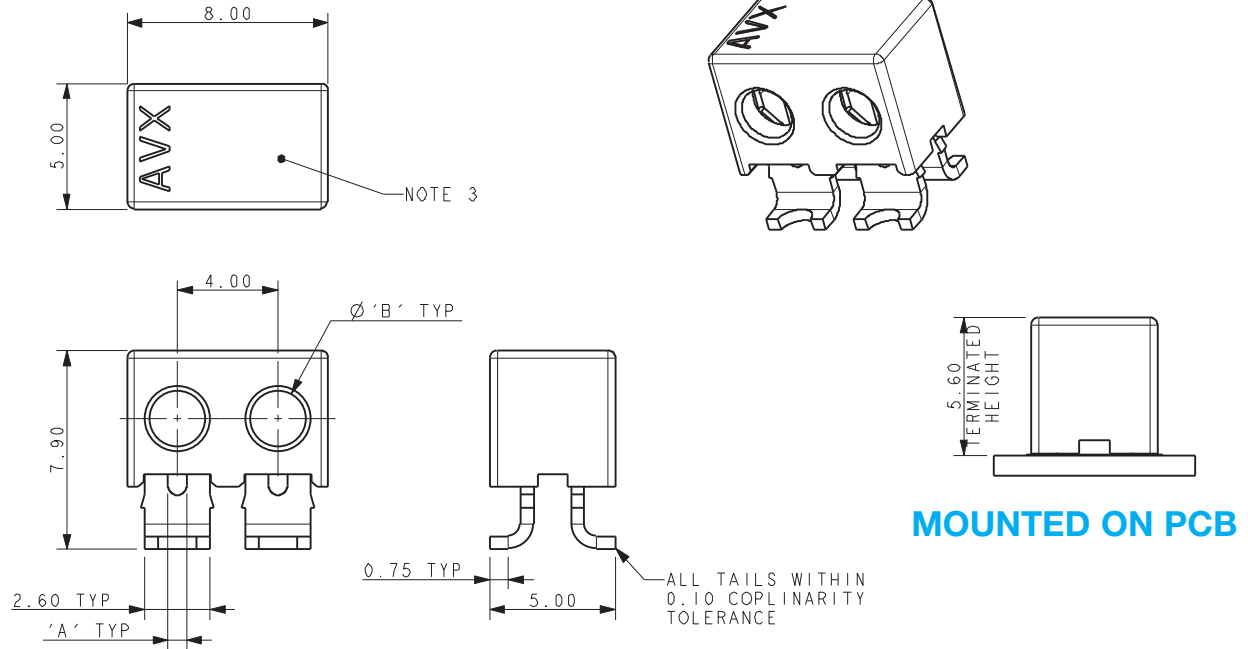

Code	Accepted Wire Gauge	A	Wire Insulation	B
701	18 AWG Stranded	0.74	Ø 1.6-2.1	2.1
711	20 AWG Solid and Stranded	0.60	Ø 1.6-2.1	2.1
722	22 AWG Solid and Stranded	0.47	Ø 1.1-1.6	1.6
732	24 AWG Solid and Stranded	0.37	Ø 1.1-1.6	1.6

**NOTES:**

- 2 WAY CONNECTOR FOR IDC WIRE TO BOARD CONNECTION. PRE-ASSEMBLED THROUGH WIRE CAP.
- CONTACT/CAP TO MATCH 18-24 AWG STRANDED WIRE INSULATION DIAMETER RANGE AS IN TABLE.
- FLAT FACE ON TOP OF CAP TO AID PICK AND PLACE ASSEMBLY.
- FOR FULL DETAILS REFER TO ELCO SPECIFICATION 201-01-139.
- ASSEMBLY PROCEDURE, REFER TO APPLICATION NOTES 201-01-140.
- GENERAL TOLERANCE  $\pm 0.20$  UNLESS STATED.
- PACKED IN TAPE AND REEL, QUANTITY PER REEL 600.
- CONNECTOR OUTLINE.
- CONTACT MATERIAL: TIN PLATED COPPER ALLOY.
- INSULATOR MATERIAL: HIGH TEMPERATURE NYLON, GLASS FILLED, UL94 V-0. COLOR REFER TO PAGE 26.

### PACKING DETAILS

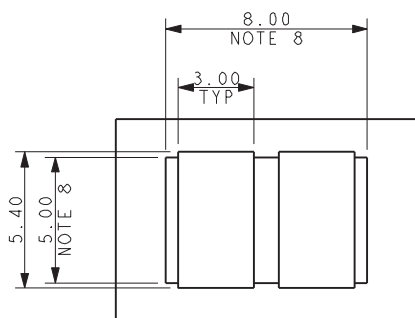

### SUGGEST PCB LAYOUT

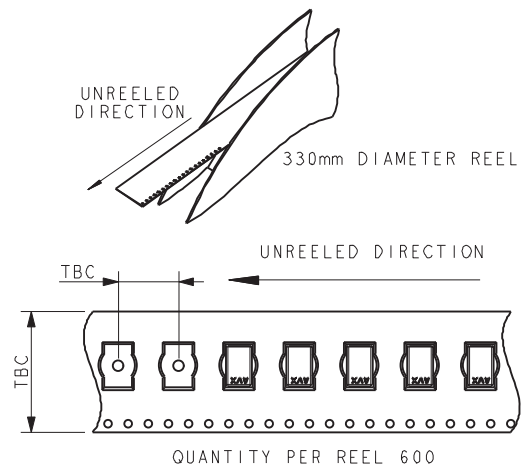

# Capped 18-24 AWG: WTB

## 9176-700

### 18 - 24 AWG 3 WAY IDC CONNECTOR THROUGH WIRE CAPPED IDC

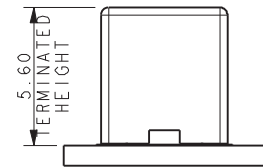
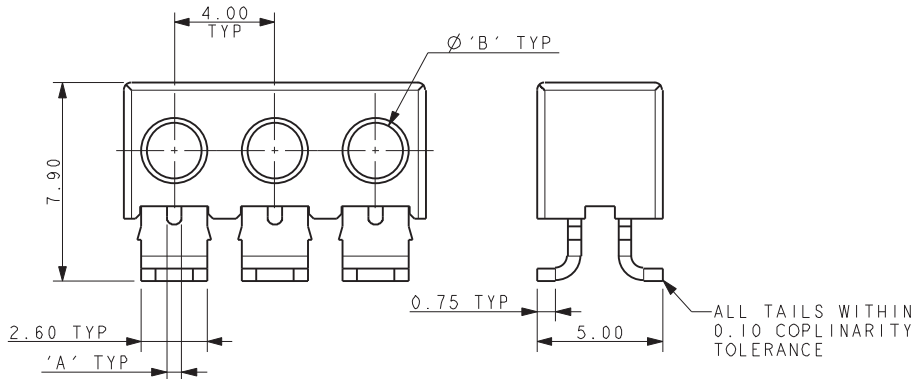
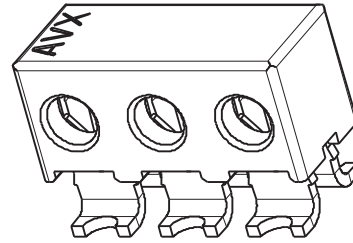
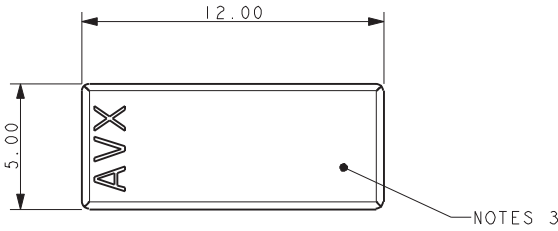

### MOUNTED ON PCB

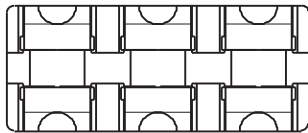

Code	Accepted Wire Gauge	A	Wire Insulation	B
701	18 AWG Stranded	0.74	Ø 1.6-2.1	2.1
711	20 AWG Solid and Stranded	0.60	Ø 1.6-2.1	2.1
722	22 AWG Solid and Stranded	0.47	Ø 1.1-1.6	1.6
732	24 AWG Solid and Stranded	0.37	Ø 1.1-1.6	1.6

#### NOTES:

- 3 WAY CONNECTOR FOR IDC WIRE TO BOARD CONNECTION. PRE-ASSEMBLED THROUGH WIRE CAP.
- CONTACT/CAP TO MATCH 18-24 AWG STRANDED WIRE INSULATION DIAMETER RANGE AS IN TABLE.
- FLAT FACE ON TOP OF CAP TO AID PICK AND PLACE ASSEMBLY.
- FOR FULL DETAILS REFER TO ELCO SPECIFICATION 201-01-139.
- ASSEMBLY PROCEDURE, REFER TO APPLICATION NOTES 201-01-140.
- GENERAL TOLERANCE  $\pm 0.20$  UNLESS STATED.
- PACKED IN TAPE AND REEL, QUANTITY PER REEL 600.
- CONNECTOR OUTLINE.
- CONTACT MATERIAL: TIN PLATED COPPER ALLOY.
- INSULATOR MATERIAL: HIGH TEMPERATURE NYLON, GLASS FILLED, UL94 V-0. COLOR REFER TO PAGE 26.

### PACKING DETAILS

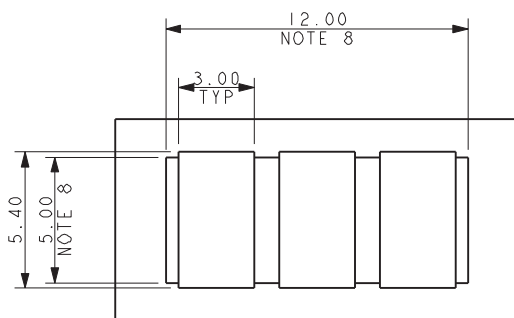

### SUGGEST PCB LAYOUT

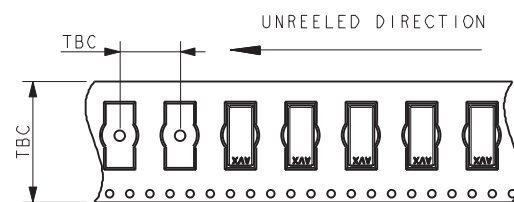
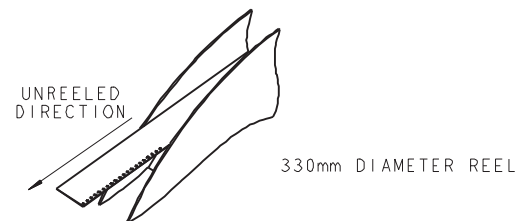

QUANTITY PER REEL 600

### 18 - 24 AWG 1 WAY IDC CONNECTOR WIRE STOP CAPPED IDC

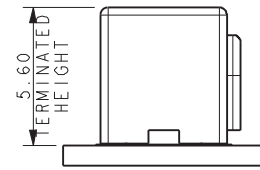
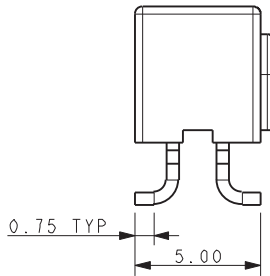
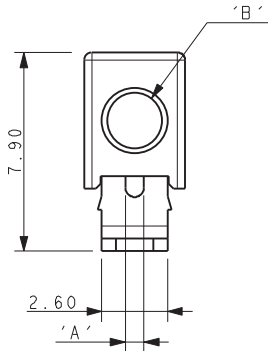
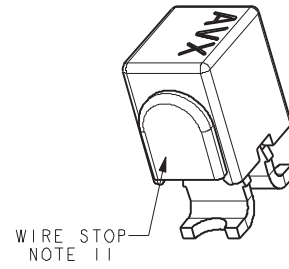
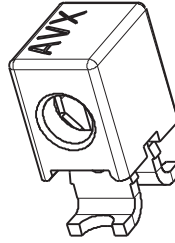
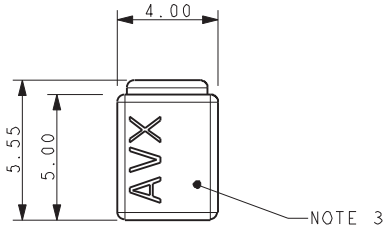

### MOUNTED ON PCB

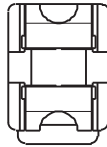

#### NOTES:

- 1 WAY CONNECTOR FOR IDC WIRE TO BOARD CONNECTION. PRE-ASSEMBLED WIRE SOFT CAP. CODE REFER TO PAGE 26.
- CONTACT/CAP TO MATCH 18-24 AWG STRANDED WIRE. INSULATION DIAMETER RANGE AS IN TABLE.
- FLAT FACE ON TOP OF CAP TO AID PICK AND PLACE ASSEMBLY.
- FOR FULL DETAILS REFER TO ELCO SPECIFICATION 201-01-139.
- ASSEMBLY PROCEDURE, REFER TO APPLICATION NOTES 201-01-140.
- GENERAL TOLERANCE  $\pm 0.20$  UNLESS STATED.
- PACKED IN TAPE AND REEL, QUANTITY PER REEL 600.
- CONNECTOR OUTLINE.
- CONTACT MATERIAL: TIN PLATED COPPER ALLOY.
- INSULATOR MATERIAL: HIGH TEMPERATURE NYLON, GLASS FILLED, UL94 V-0. COLOR REFER TO PAGE 26.
- WIRE STOP CAP PROTECTS END OF WIRE.

Code	Accepted Wire Gauge	A	Wire Insulation	B
701	18 AWG Stranded	0.74	$\varnothing$ 1.6-2.1	2.1
711	20 AWG Solid and Stranded	0.60	$\varnothing$ 1.6-2.1	2.1
722	22 AWG Solid and Stranded	0.47	$\varnothing$ 1.1-1.6	1.6
732	24 AWG Solid and Stranded	0.37	$\varnothing$ 1.1-1.6	1.6

### PACKING DETAILS

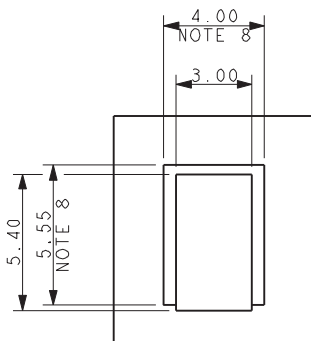

### SUGGEST PCB LAYOUT

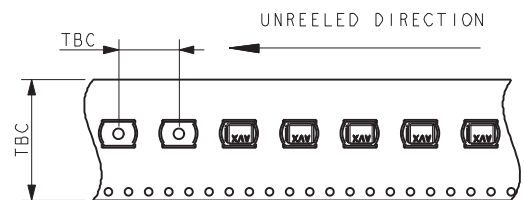
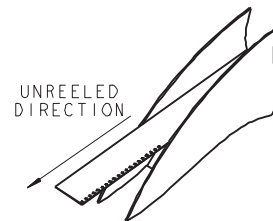

QUANTITY PER REEL 600

### 18 - 24 AWG 2 WAY IDC CONNECTOR WIRE STOP CAPPED IDC

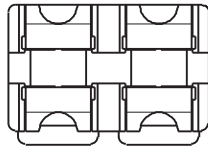
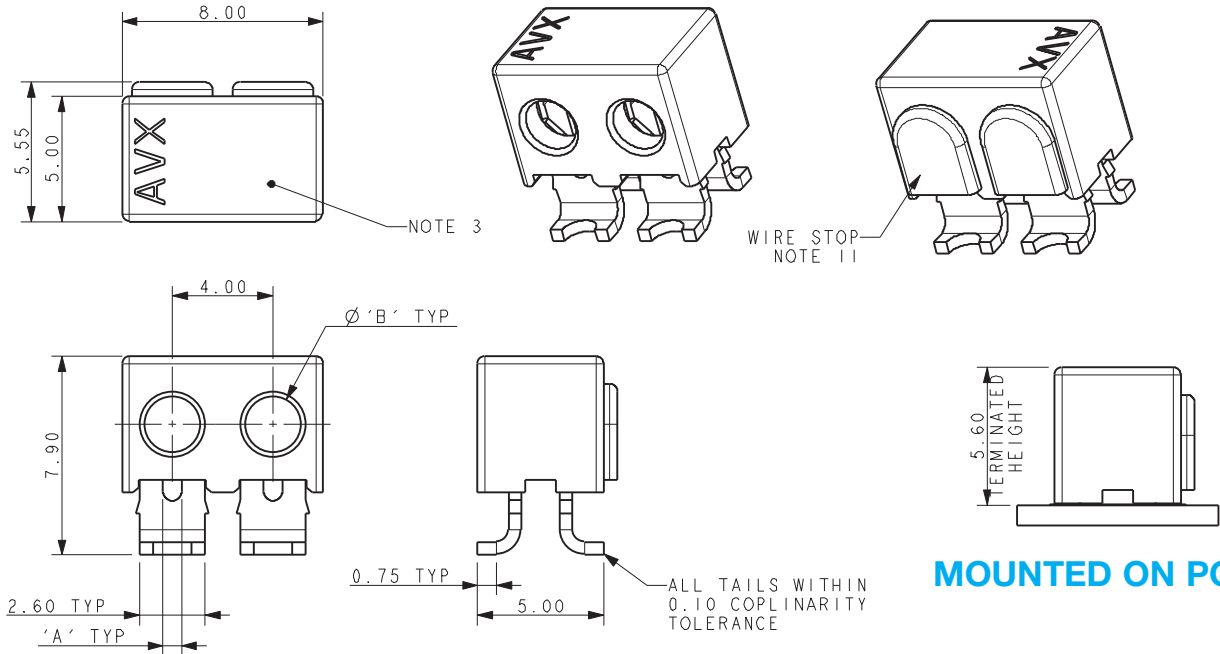

Code	Accepted Wire Gauge	A	Wire Insulation	B
701	18 AWG Stranded	0.74	Ø 1.6-2.1	2.1
711	20 AWG Solid and Stranded	0.60	Ø 1.6-2.1	2.1
722	22 AWG Solid and Stranded	0.47	Ø 1.1-1.6	1.6
732	24 AWG Solid and Stranded	0.37	Ø 1.1-1.6	1.6

#### NOTES:

- 2 WAY CONNECTOR FOR IDC WIRE TO BOARD CONNECTION. PRE-ASSEMBLED WIRE SOFT CAP. CODE REFER TO PAGE 26.
- CONTACT/CAP TO MATCH 18-24 AWG STRANDED WIRE. INSULATION DIAMETER RANGE AS IN TABLE.
- FLAT FACE ON TOP OF CAP TO AID PICK AND PLACE ASSEMBLY.
- FOR FULL DETAILS REFER TO ELCO SPECIFICATION 201-01-139.
- ASSEMBLY PROCEDURE, REFER TO APPLICATION NOTES 201-01-140.
- GENERAL TOLERANCE  $\pm 0.20$  UNLESS STATED.
- PACKED IN TAPE AND REEL, QUANTITY PER REEL 600.
- CONNECTOR OUTLINE.
- CONTACT MATERIAL: TIN PLATED COPPER ALLOY.
- INSULATOR MATERIAL: HIGH TEMPERATURE NYLON, GLASS FILLED, UL94 V-0. COLOR REFER TO PAGE 26.
- WIRE STOP CAP PROTECTS END OF WIRE.

### PACKING DETAILS

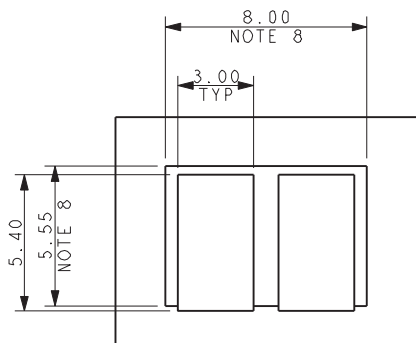

### SUGGEST PCB LAYOUT

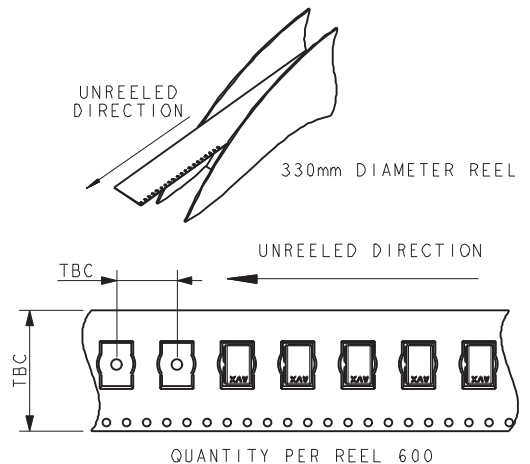



# Capped 18-24 AWG: WTB

9176-700

## 18 - 24 AWG 3 WAY IDC CONNECTOR WIRE STOP CAPPED IDC

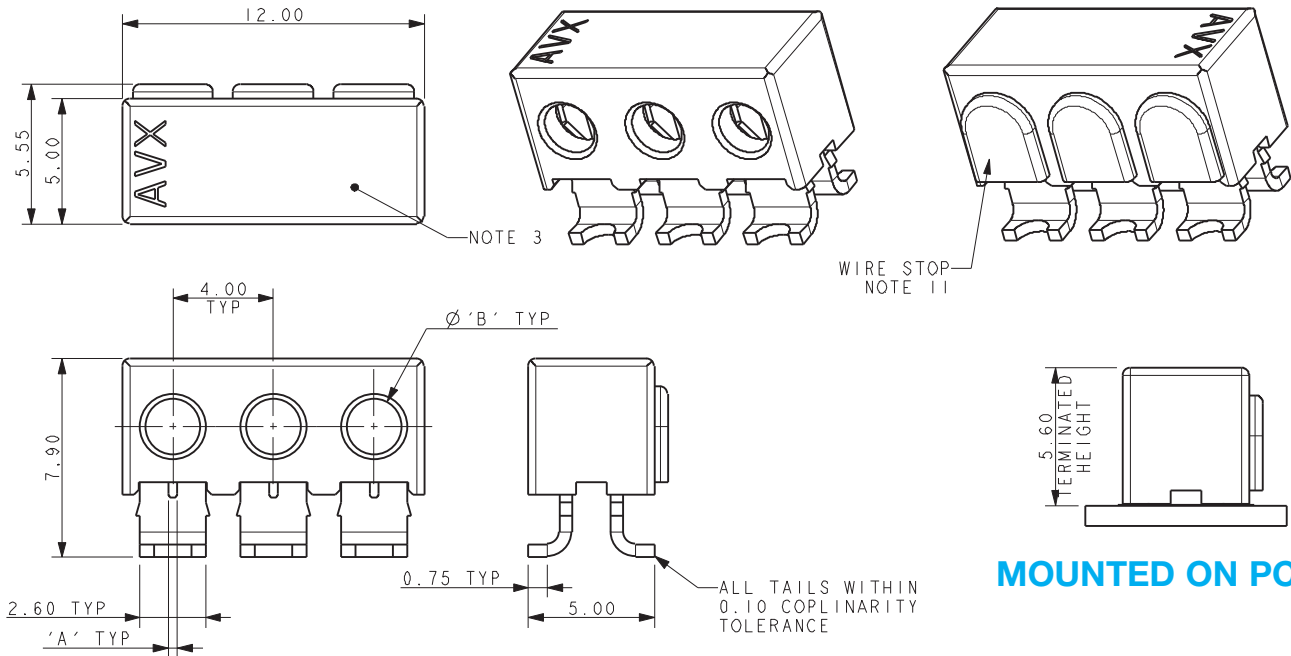

**MOUNTED ON PCB**

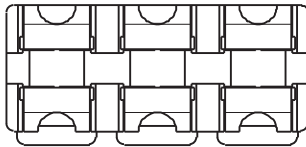

Code	Accepted Wire Gauge	A	Wire Insulation	B
701	18 AWG Stranded	0.74	Ø 1.6-2.1	2.1
711	20 AWG Solid and Stranded	0.60	Ø 1.6-2.1	2.1
722	22 AWG Solid and Stranded	0.47	Ø 1.1-1.6	1.6
732	24 AWG Solid and Stranded	0.37	Ø 1.1-1.6	1.6

**NOTES:**

- 2 WAY CONNECTOR FOR IDC WIRE TO BOARD CONNECTION. PRE-ASSEMBLED WIRE SOFT CAP. CODE REFER TO PAGE 26.
- CONTACT/CAP TO MATCH 18-24 AWG STRANDED WIRE. INSULATION DIAMETER RANGE AS IN TABLE.
- FLAT FACE ON TOP OF CAP TO AID PICK AND PLACE ASSEMBLY.
- FOR FULL DETAILS REFER TO ELCO SPECIFICATION 201-01-139.
- ASSEMBLY PROCEDURE, REFER TO APPLICATION NOTES 201-01-140.
- GENERAL TOLERANCE  $\pm 0.20$  UNLESS STATED.
- PACKED IN TAPE AND REEL, QUANTITY PER REEL 600.
- CONNECTOR OUTLINE.
- CONTACT MATERIAL: TIN PLATED COPPER ALLOY.
- INSULATOR MATERIAL: HIGH TEMPERATURE NYLON, GLASS FILLED, UL94 V-0. COLOR REFER TO PAGE 26.
- WIRE STOP CAP PROTECTS END OF WIRE.

## PACKING DETAILS

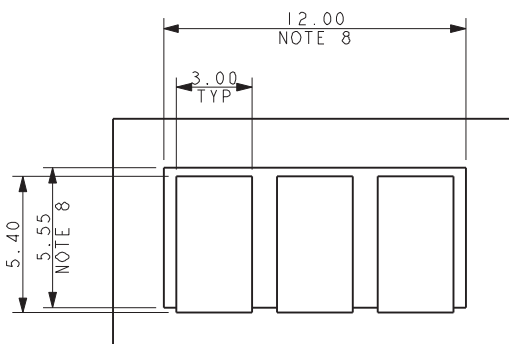

**SUGGEST PCB LAYOUT**

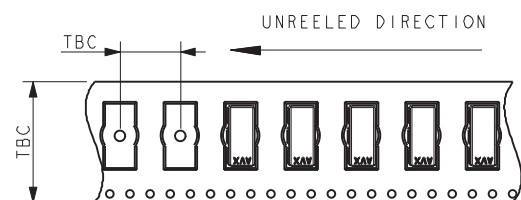
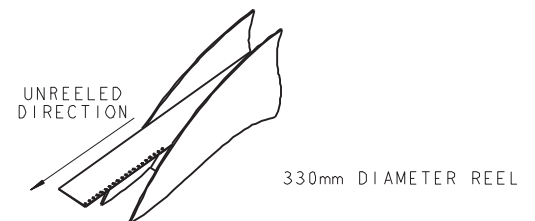

QUANTITY PER REEL 600

18-24 AWG ASSEMBLED CAPPED IDC CONNECTORS

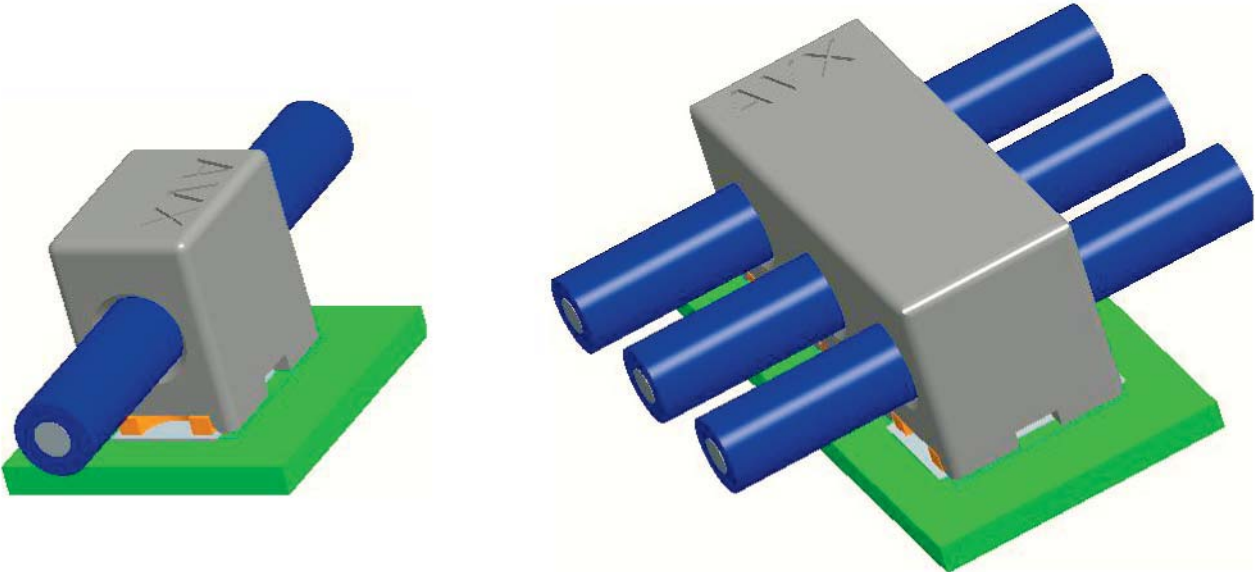

TYPICAL THROUGH WIRE ASSEMBLY

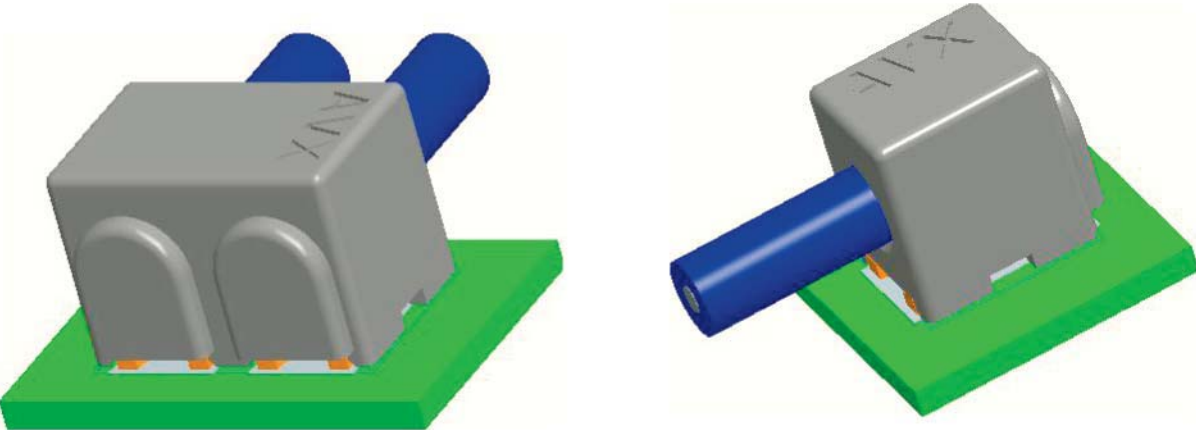

TYPICAL WIRE STOP ASSEMBLY

# Single IDC Contact 22-28 AWG: WTB

9176-400



The 917X series of surface mount Insulation Displacement Connectors (IDC) were developed to meet the harsh automotive and industrial market applications for connecting individual wires directly to a PCB ranging from 14 AWG to 28 AWG. This industry proven contact system has been tested to automotive levels of shock, vibration, and temperature cycling to prove their reliability and robustness. This new single contact was developed as a standalone component to enhance the application uses with the IDC technology. The simplicity of inserting a wire into an SMT contact with a small tool or optional retention / termination cap allows a wide range of devices to be connected to the PCB without soldering. In SSL applications specifically, these contacts are used to bring power and signal onto the PCB or are used to daisy chain multiple boards together in a long string. While the IDC contact provides a gas-tight connection to conductor of the wire, the optional cap provides a positive strain relief even in the harshest conditions. In case of repair, the wires can be removed and replace up to three times.

The single 9176-400 series contact and cap accepts 22 AWG to 28 AWG wires with an insulation diameter ranging from 1.0mm to 1.5mm. These dual beam contacts support a 6 amp current rating with a large SMT solder base to provide maximum stability on the PCB. The optional locking strain relief cap acts as the termination tool for severe vibration applications.

## APPLICATIONS

- Connecting discrete wire components directly to the PCB
- Bringing power and signals onto a PCB
- Daisy chaining PCB's together to create a continuous string of boards
- Application notes: refer to 201-01-124

## FEATURES AND BENEFITS

- IDC contact is supplied in T&R pockets for standard SMT placement
- IDC contact provides a gas-tight connection to the PCB for long term reliability
- Optional termination cap provides additional strain relief for severe environments
- Tested to automotive levels on shock, vibration and temperature cycling for reliability
- Reduced total applied cost versus solder or crimp processes
- Individual contacts can be located anywhere on the PCB based on specific application

## ELECTRICAL

- Current Rating: 6 Amps/Contact
- Voltage Rating: Dependant on component proximity

## ENVIRONMENTAL

- Operating Temperature: -40°C to +125°C

## MECHANICAL

- Insulator Material: Nylon 46: UL94V0
- Contact Material: Phosphor Bronze
- Plating: Tin over Nickel
- Durability: 3 Cycles

## HOW TO ORDER – CONTACT OPTIONS

<b>70</b>	<b>9176</b>	<b>001</b>	<b>4XX</b>	<b>006</b>																
Prefix	Series	Number of Ways	Wire Gauge Size	Plating Option																
70 = Contact				006 = Pure Tin all over																
		<table border="1"> <thead> <tr> <th>Code</th> <th>No of Ways</th> <th>Details</th> </tr> </thead> <tbody> <tr> <td>001</td> <td>1</td> <td>Page 33</td> </tr> </tbody> </table>	Code	No of Ways	Details	001	1	Page 33	<table border="1"> <thead> <tr> <th>Code</th> <th>Accepted Wire Gauge</th> </tr> </thead> <tbody> <tr> <td>422</td> <td>22 Gauge Solid or Stranded</td> </tr> <tr> <td>432</td> <td>24 Gauge Solid or Stranded</td> </tr> <tr> <td>422</td> <td>26 Gauge Solid or Stranded</td> </tr> <tr> <td>443</td> <td>28 Gauge Solid or Stranded</td> </tr> </tbody> </table>	Code	Accepted Wire Gauge	422	22 Gauge Solid or Stranded	432	24 Gauge Solid or Stranded	422	26 Gauge Solid or Stranded	443	28 Gauge Solid or Stranded	
Code	No of Ways	Details																		
001	1	Page 33																		
Code	Accepted Wire Gauge																			
422	22 Gauge Solid or Stranded																			
432	24 Gauge Solid or Stranded																			
422	26 Gauge Solid or Stranded																			
443	28 Gauge Solid or Stranded																			

## HOW TO ORDER – CAP OPTIONS

<b>60</b>	<b>9176</b>	<b>001</b>	<b>415</b>	<b>X00</b>																				
Prefix	Series	Number of Ways	Wire Gauge Size	Insulator Color																				
60 = Cap																								
		<table border="1"> <thead> <tr> <th>Code</th> <th>No of Ways</th> <th>Details</th> </tr> </thead> <tbody> <tr> <td>001</td> <td>1</td> <td>Page 35</td> </tr> </tbody> </table>	Code	No of Ways		Details	001	1	Page 35	<table border="1"> <thead> <tr> <th>Code</th> <th>Wire Insulation</th> </tr> </thead> <tbody> <tr> <td>415</td> <td>Ø 0.75-1.5</td> </tr> </tbody> </table>	Code	Wire Insulation	415	Ø 0.75-1.5	<table border="1"> <thead> <tr> <th>Code</th> <th>Color</th> <th>Application</th> </tr> </thead> <tbody> <tr> <td>000</td> <td>Black</td> <td>Industrial</td> </tr> <tr> <td>100</td> <td>White</td> <td>Lighting</td> </tr> </tbody> </table>	Code	Color	Application	000	Black	Industrial	100	White	Lighting
Code	No of Ways	Details																						
001	1	Page 35																						
Code	Wire Insulation																							
415	Ø 0.75-1.5																							
Code	Color	Application																						
000	Black	Industrial																						
100	White	Lighting																						

## CONNECTOR/TOOLING PART NUMBER MATRIX

SERIES 9176-500 IDC				HAND INSERTION TOOLING*		ACCESSORY CAPS		
AWG	Wire Insulation	Positions	Part Number	Plastic (medium volume)	Metal (high volume)	Cap Application Tool	White	Black
22	Ø 1.0 - 1.5	1p	709176001422006	069176702201000	069176702101000	069176702301000	609176001415100	609176001415000
24	Ø 1.0 - 1.5	1p	709176001432006	069176702201000	069176702101000	069176702301000	609176001415100	609176001415000
26	Ø 0.7 - 1.0	1p	709176001443006	069176702201000	069176702101000	069176702301000	609176001415100	609176001415000
28	Ø 0.7 - 1.0	1p	709176001443006	069176702201000	069176702101000	069176702301000	609176001415100	609176001415000

\* Hand Insertion Tooling and Cap Application - Universal Hand Tool 067000773001000; Consult Application Notes 201-01-124

Certification: UL File #E90723



### CONTACT DETAILS

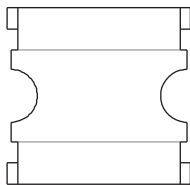
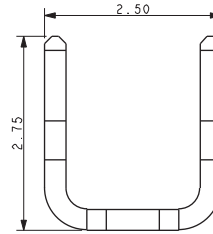
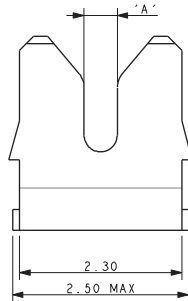

AREA AVAILABLE FOR PICK & PLACE

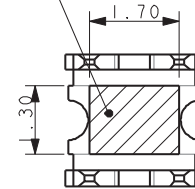

Code	Accepted Wire Gauge	A
422	22 Gauge Solid or Stranded	0.47
432	24 Gauge Solid or Stranded	0.37
443	26-28 Gauge Solid or Stranded	0.20

#### NOTES:

- CONNECTOR FOR IDC WIRE TO BOARD CONNECTION.
- CONTACT MATERIAL: PHOSPHOR BRONZE.
- CONTACT PLATING: PURE TIN.
- CONNECTOR DESIGNED TO ACCEPT BETWEEN 22AWG AND 28AWG SOLID AND STRANDED WIRE. SEE TABLE.
- ALL DIMENSIONS  $\pm 0.20$  UNLESS TOLERANCED.
- FOR FULL PRODUCT SPECIFICATION REFER TO ELCO SPEC 201-01-126 AND APPLICATION NOTES 201-01-124.
- SMT PCB LAYOUT, REFER TO PAGE 36.
- PACKING IN TAPE AND REEL, QUANTITY 2000 PER REEL.
- WHEN REQUIRED, MATCHING CAP DETAILS ON DRAWING 60-9176-001-4XX-X06S.
- ASSEMBLY TOOLING ON PAGE 37 FOR WIRE INTO CONTACT AND PAGE 36 FOR CAP.
- UL REFERENCE E90723, THIS UL REFERENCE ALSO APPLIES WHEN COMBINED WITH AVX SPECIFIED OPTIONAL CAP.

### PACKING DETAILS

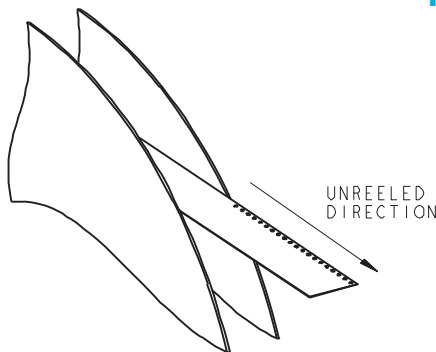

REEL QTY	2 000
LEADER	480MM
TRAILER	120MM

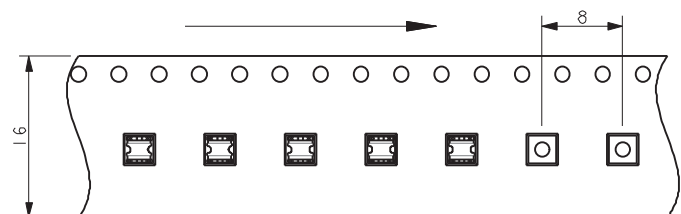

### 22-28 AWG IDC WIRE TO BOARD CONNECTOR SINGLE CONTACT

#### SMT PCB LAYOUT

PURE TIN PADS

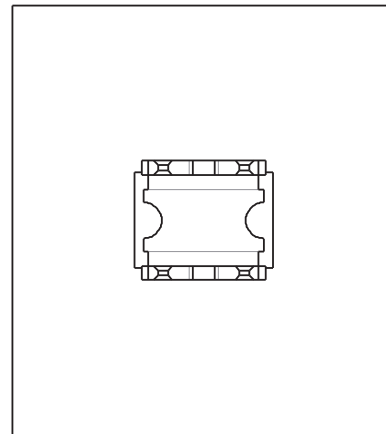
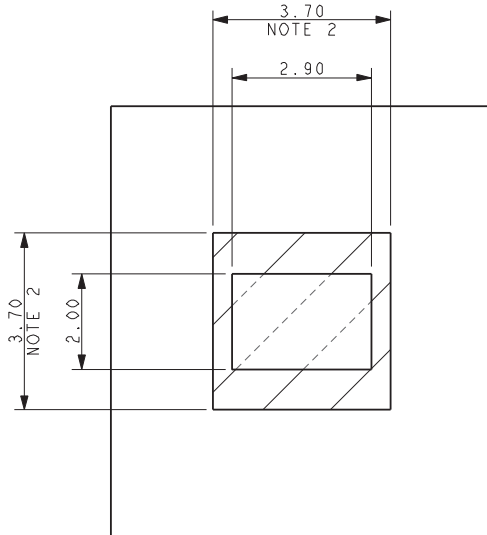

ORIENTATION OF CONTACT ON PAD

#### ASSEMBLED/INSTALLED PRODUCTS

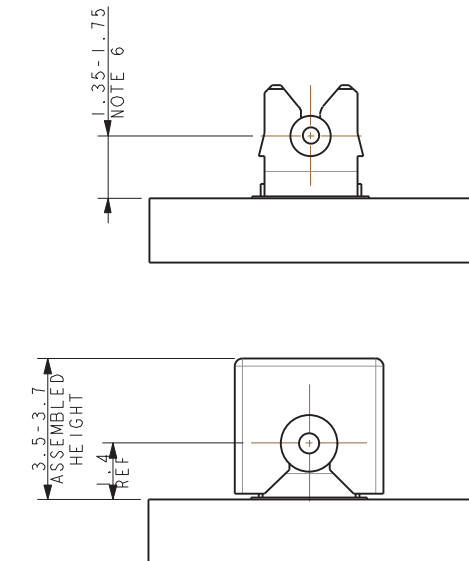

CAP. SEE DRAWING  
60-9176-001-4XX-X00S

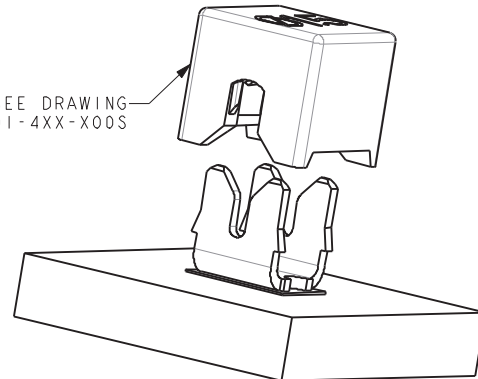

#### NOTES:

1. CONNECTOR CAN BE USED WITH CONTACT ONLY OR WITH OPTIONAL CAP.
2. OUTLINE OF CAP WHERE USED.
3. FOR FULL PRODUCT SPECIFICATION REFER TO ELCO SPEC 201-01-126 AND APPLICATION NOTES 201-01-124.
4. ALL DIMENSIONS  $\pm 0.20$  UNLESS TOLERANCED.
5. ASSEMBLY TOOLING ON PAGE 38 FOR WIRE INTO CONTACT AND PAGE 37 FOR CAP.
6. WIRE CENTER LINE HEIGHT ABOVE THE PCB. THIS INCLUDES AN ALLOWANCE OF 0.10MM FOR SOLDER AND 0.035MM FOR PAD THICKNESS. NO ALLOWANCE HAS BEEN MADE FOR SOLDER RESIST OR OTHER FEATURES.

### ASSEMBLY TOOLING – CAP USED

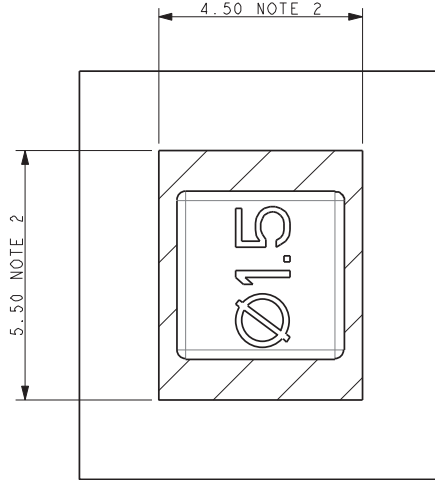

**NOTES:**

1. ASSEMBLY TOOLING FOR CAP.
2. MINIMUM AREA OF PCB TO BE KEPT CLEAR OF COMPONENTS, TRACKS PERMISSIBLE.
3. WIRE AND CAP INSERTED IN ONE OPERATION.
4. REFER TO APPLICATION NOTE 201-01-124 FOR FURTHER INFORMATION.
5. REFER TO PAGE 38 FOR ASSEMBLY WITHOUT CAP.

### CAP APPLICATION TOOL – PLASTIC

06-9176-7023-01-000

### METAL TOOL – HIGH VOLUME

06-9176-7024-01-000

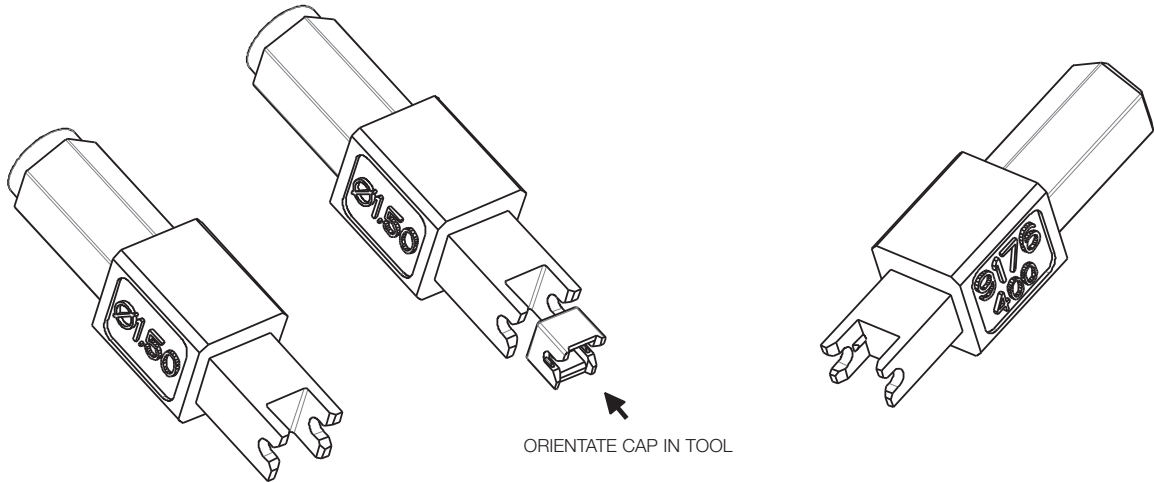

### UNIVERSAL HANDLE

06-7000-7730-01-000

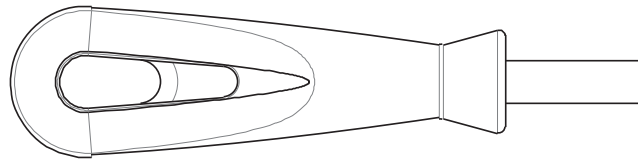

### CONNECTOR/TOOLING PART NUMBER MATRIX

SERIES 9176-400 IDC				HAND INSERTION TOOLING*		ACCESSORY CAPS		
AWG	Wire Insulation	Positions	Part Number	Plastic (medium volume)	Metal (high volume)	Cap Application Tool	White	Black
22	Ø 1.0 - 1.5	1p	709176001422006	069176702201000	069176702101000	069176702301000	609176001415100	609176001415000
24	Ø 1.0 - 1.5	1p	709176001432006	069176702201000	069176702101000	069176702301000	609176001415100	609176001415000
26	Ø 0.7 - 1.0	1p	709176001443006	069176702201000	069176702101000	069176702301000	609176001415100	609176001415000
28	Ø 0.7 - 1.0	1p	709176001443006	069176702201000	069176702101000	069176702301000	609176001415100	609176001415000

\* Hand Insertion Tooling and Cap Application - Universal Hand Tool 067000773001000; Consult Application Notes 201-01-124

### ASSEMBLY TOOLING – CAP NOT USED WIRE ONTO CONTACT

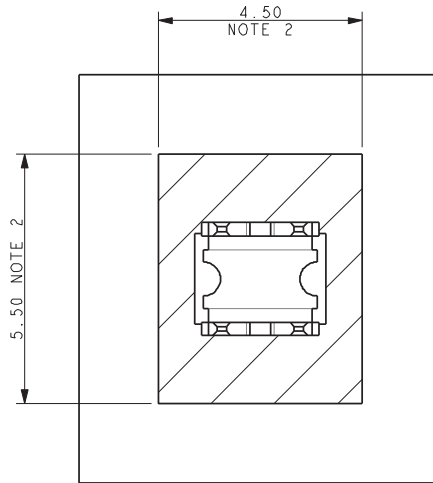

**METAL TOOL  
HIGH VOLUME**  
06-9176-7021-01-000

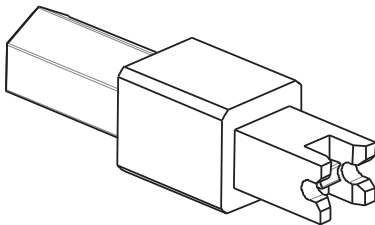

**PLASTIC TOOL  
LOW/MEDIUM VOLUME**  
06-9176-7022-01-000

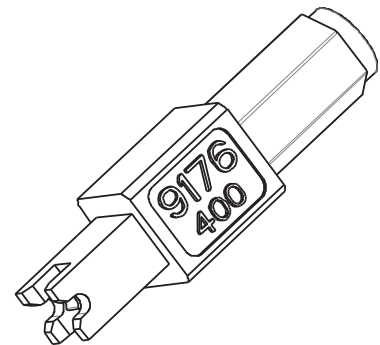

**UNIVERSAL HANDLE**  
06-7000-7730-01-000

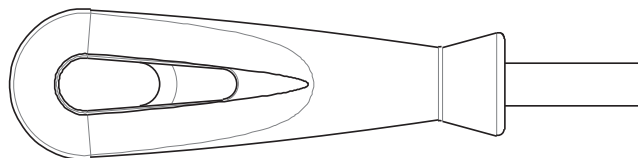

**NOTES:**

1. ASSEMBLY TOOLING FOR CONTACT ONLY. NO CAP USED.
2. MINIMUM AREA OF PCB TO BE KEPT CLEAR OF COMPONENTS, TRACKS PERMISSIBLE.
3. REFER TO APPLICATION NOTE 201-01-124 FOR FURTHER INFORMATION.
4. INSERT CORRECT TOOL INTO HANDLE, MAGNETIC RETENTION.
5. REFER TO PAGE 37 FOR ASSEMBLY WITH CAP.

**CAP DETAILS**

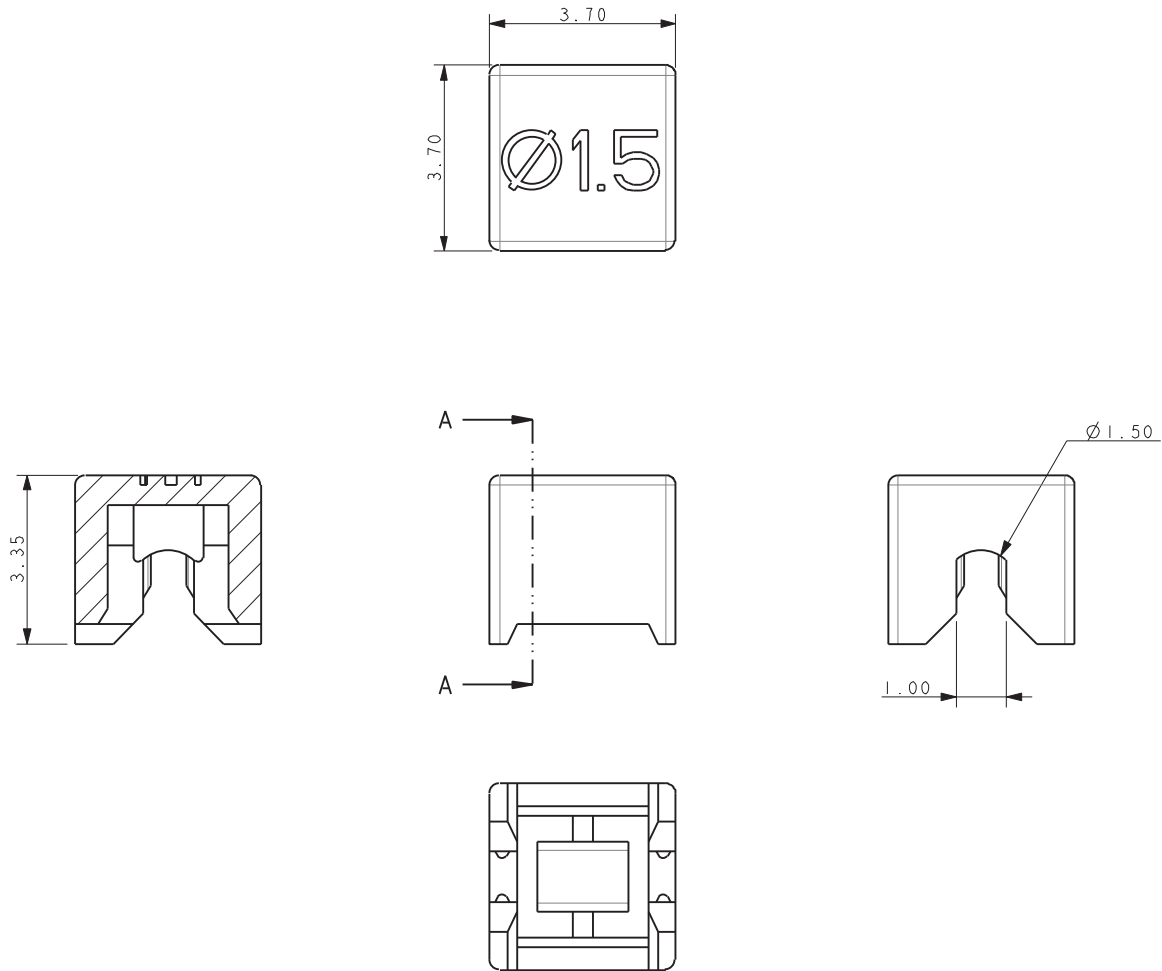

**NOTES:**

1. CAP FOR IDC WIRE TO BOARD CONNECTION.
2. CAP MATERIAL: GLASS FILLED NYLON 46, COLOR SEE PAGE 32.
3. CAPS DESIGNED TO ACCOMMODATE WIRE INSULATION DIAMETERS 0.75MM TO 1.5MM.
4. ALL DIMENSIONS  $\pm 0.20$  UNLESS TOLERANCED.
5. FOR FULL PRODUCT SPECIFICATION REFER TO ELCO SPEC 201-01-126, APPLICATION NOTES 201-01-124.
6. PACKING IN BAGS, QUANTITY 2000 PER BAG.
7. FOR INSTALATION DETAILS REFER TO DRAWING 70-9176-001-4XX-006S.



# Single IDC Contact 18-24 AWG: WTB

9176-500

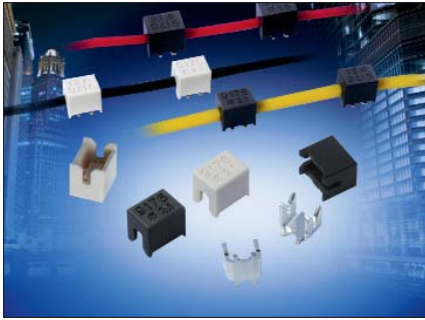

The 917X series of surface mount Insulation Displacement Connectors (IDC) were developed to meet the harsh automotive and industrial market applications for connecting individual wires directly to a PCB ranging from 14 AWG to 28 AWG. This industry proven contact system has been tested to automotive levels of shock, vibration, and temperature cycling to prove their reliability and robustness. This new single contact was developed as a standalone component to enhance the application uses with the IDC technology. The simplicity of inserting a wire into an SMT contact with a small tool or optional retention / termination cap allows a wide range of devices to be connected to the PCB without soldering. In SSL applications specifically, these contacts are used to bring power and signal onto the PCB or are used to daisy chain multiple boards together in a long string. While the IDC contact provides a gas-tight connection to conductor of the wire, the optional cap provides a positive strain relief even in the harshest conditions. In case of repair, the wires can be removed and replace up to three times.

The single 9176 series contact and cap accepts 18 AWG to 24 AWG wires with an insulation diameter ranging from 1.1mm to 2.1mm. These dual beam contacts support a 10 amp current rating with a large SMT solder base to provide maximum stability on the PCB. The optional locking strain relief cap acts as the termination tool for severe vibration applications.

## APPLICATIONS

- Connecting discrete wire components directly to the PCB
- Bringing power and signals onto a PCB
- Daisy chaining PCB's together to create a continuous string of boards
- Application notes: refer to 201-01-124

## FEATURES AND BENEFITS

- IDC contact is supplied in T&R pockets for standard SMT placement
- IDC contact provides a gas-tight connection to the PCB for long term reliability
- Optional termination cap provides additional strain relief for severe environments
- Tested to automotive levels on shock, vibration and temperature cycling for reliability
- Reduced total applied cost versus solder or crimp processes
- Individual contacts can be located anywhere on the PCB based on specific application

## ELECTRICAL

- Current Rating: 10 Amps/Contact
- Voltage Rating: Dependant on component proximity

## ENVIRONMENTAL

- Operating Temperature: -40°C to +125°C

## MECHANICAL

- Insulator Material: Nylon 46: UL94V0
- Contact Material: Phosphor Bronze
- Plating: Tin over Nickel
- Durability: 3 Cycles

## HOW TO ORDER – CONTACT OPTIONS

<b>70</b>	<b>9176</b>	<b>001</b>	<b>5XX</b>	<b>006</b>																
Prefix	Series	Number of Ways	Wire Gauge Size	Plating Option																
70 = Contact		<table border="1"> <thead> <tr> <th>Code</th> <th>No of Ways</th> <th>Details</th> </tr> </thead> <tbody> <tr> <td>001</td> <td>1</td> <td>Page 38</td> </tr> </tbody> </table>	Code	No of Ways	Details	001	1	Page 38	<table border="1"> <thead> <tr> <th>Code</th> <th>Accepted Wire Gauge</th> </tr> </thead> <tbody> <tr> <td>501</td> <td>18 Gauge Stranded</td> </tr> <tr> <td>511</td> <td>20 Gauge Solid or Stranded</td> </tr> <tr> <td>522</td> <td>22 Gauge Solid or Stranded</td> </tr> <tr> <td>532</td> <td>24 Gauge Solid or Stranded</td> </tr> </tbody> </table>	Code	Accepted Wire Gauge	501	18 Gauge Stranded	511	20 Gauge Solid or Stranded	522	22 Gauge Solid or Stranded	532	24 Gauge Solid or Stranded	006 = Pure Tin all over
Code	No of Ways	Details																		
001	1	Page 38																		
Code	Accepted Wire Gauge																			
501	18 Gauge Stranded																			
511	20 Gauge Solid or Stranded																			
522	22 Gauge Solid or Stranded																			
532	24 Gauge Solid or Stranded																			

## HOW TO ORDER – CAP OPTIONS

<b>60</b>	<b>9176</b>	<b>001</b>	<b>5XX</b>	<b>X00</b>																						
Prefix	Series	Number of Ways	Wire Gauge Size	Insulator Color																						
60 = Cap		<table border="1"> <thead> <tr> <th>Code</th> <th>No of Ways</th> <th>Details</th> </tr> </thead> <tbody> <tr> <td>001</td> <td>1</td> <td>Page 42</td> </tr> </tbody> </table>	Code	No of Ways		Details	001	1	Page 42	<table border="1"> <thead> <tr> <th>Code</th> <th>Wire Insulation (AWG)</th> </tr> </thead> <tbody> <tr> <td>516</td> <td>1.1-1.6 (22-24)</td> </tr> <tr> <td>521</td> <td>1.6-2.1 (18-20)</td> </tr> </tbody> </table>	Code	Wire Insulation (AWG)	516	1.1-1.6 (22-24)	521	1.6-2.1 (18-20)	<table border="1"> <thead> <tr> <th>Code</th> <th>Color</th> <th>Application</th> </tr> </thead> <tbody> <tr> <td>000</td> <td>Black</td> <td>Industrial</td> </tr> <tr> <td>100</td> <td>White</td> <td>Lighting</td> </tr> </tbody> </table>	Code	Color	Application	000	Black	Industrial	100	White	Lighting
Code	No of Ways	Details																								
001	1	Page 42																								
Code	Wire Insulation (AWG)																									
516	1.1-1.6 (22-24)																									
521	1.6-2.1 (18-20)																									
Code	Color	Application																								
000	Black	Industrial																								
100	White	Lighting																								

## CONNECTOR/TOOLING PART NUMBER MATRIX

SERIES 9176-500 IDC				HAND INSERTION TOOLING*		ACCESSORY CAPS		
AWG	Wire Insulation	Positions	Part Number	Plastic (medium volume)	Metal (high volume)	Cap Application Tool	White	Black
18	Ø 1.6 - 2.1	1p	709176001501006	069176702001000	069176701901000	069176701801000	609176001521100	609176001521000
20	Ø 1.6 - 2.1	1p	709176001511006	069176702001000	069176701901000	069176701801000	609176001521100	609176001521000
22	Ø 1.1 - 1.6	1p	709176001522006	069176702002000	069176701902000	069176701801000	609176001516100	609176001516000
24	Ø 1.1 - 1.6	1p	709176001532006	069176702002000	069176701902000	069176701801000	609176001516100	609176001516000

\* Hand Insertion Tooling and Cap Application - Universal Hand Tool 067000773001000; Consult Application Notes 201-01-124

Certification: UL File #E90723



### CONTACT DETAILS

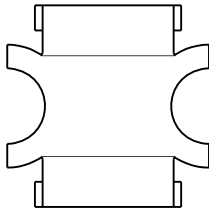
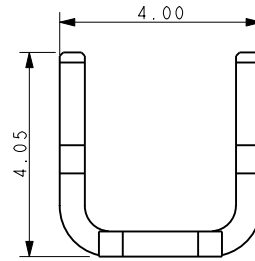
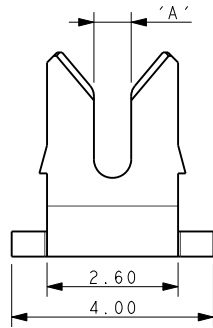

AREA AVAILABLE FOR  
PICK & PLACE 2.00mm SQUARE

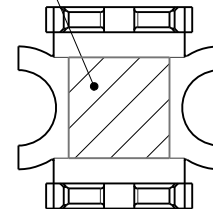

Code	Accepted Wire Gauge	A
501	18 AWG Stranded	0.72
511	20 AWG Solid and Stranded	0.60
522	22 AWG Solid and Stranded	0.47
532	24 AWG Solid and Stranded	0.37

#### NOTES:

- CONNECTOR FOR IDC WIRE TO BOARD CONNECTION.
- CONTACT MATERIAL: PHOSPHOR BRONZE.
- CONTACT PLATING: PURE TIN.
- CONNECTOR DESIGNED TO ACCEPT BETWEEN 18 AND 24 GAUGE STRANDED WIRE. SEE TABLE.
- ALL DIMENSIONS FOR REFERENCE UNLESS OTHERWISE STATED.
- FOR FULL PRODUCT SPECIFICATION REFER TO ELCO SPEC 201-01-106 AND APPLICATION NOTES 201-01-124.
- SMT PCB LAYOUT, REFER TO PAGE 39.
- PACKING IN TAPE AND REEL, QUANTITY 1000 PER REEL.
- WHEN REQUIRED, MATCHING CAP DETAILS ON DRAWING 60-9176-001-5XX-X00S.
- ASSEMBLY TOOLING ON PAGE 40 (WITH CAP AND WITHOUT CAP).

### PACKING DETAILS

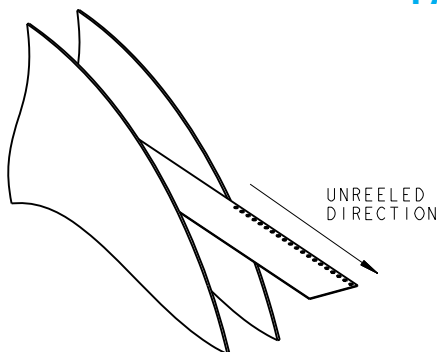

REEL QTY	1000
LEADER	480MM
TRAILER	120MM

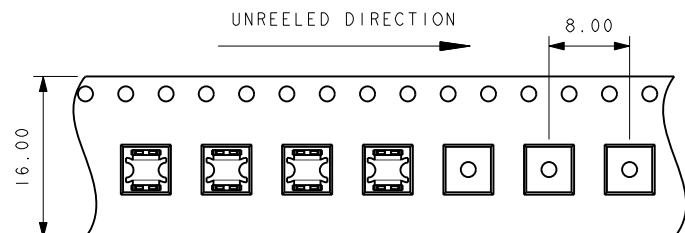

### 18-24 AWG IDC WIRE TO BOARD CONNECTOR SINGLE CONTACT

#### SMT PCB LAYOUT

PURE TIN PADS

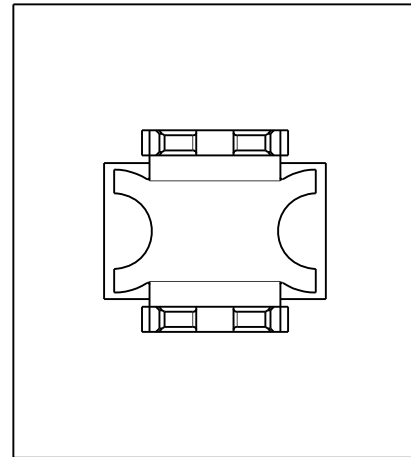
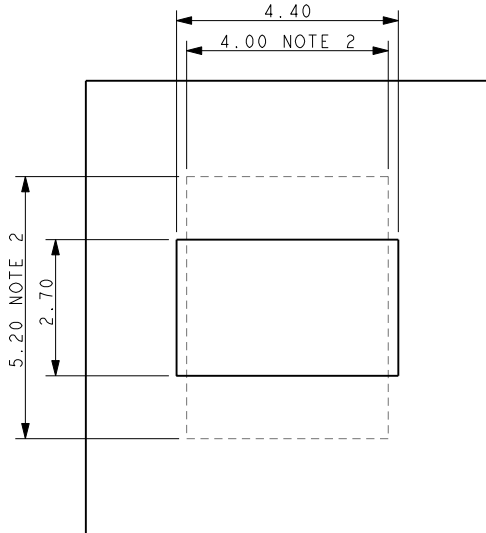

ORIENTATION OF CONTACT ON PAD

#### ASSEMBLED/INSTALLED PRODUCTS

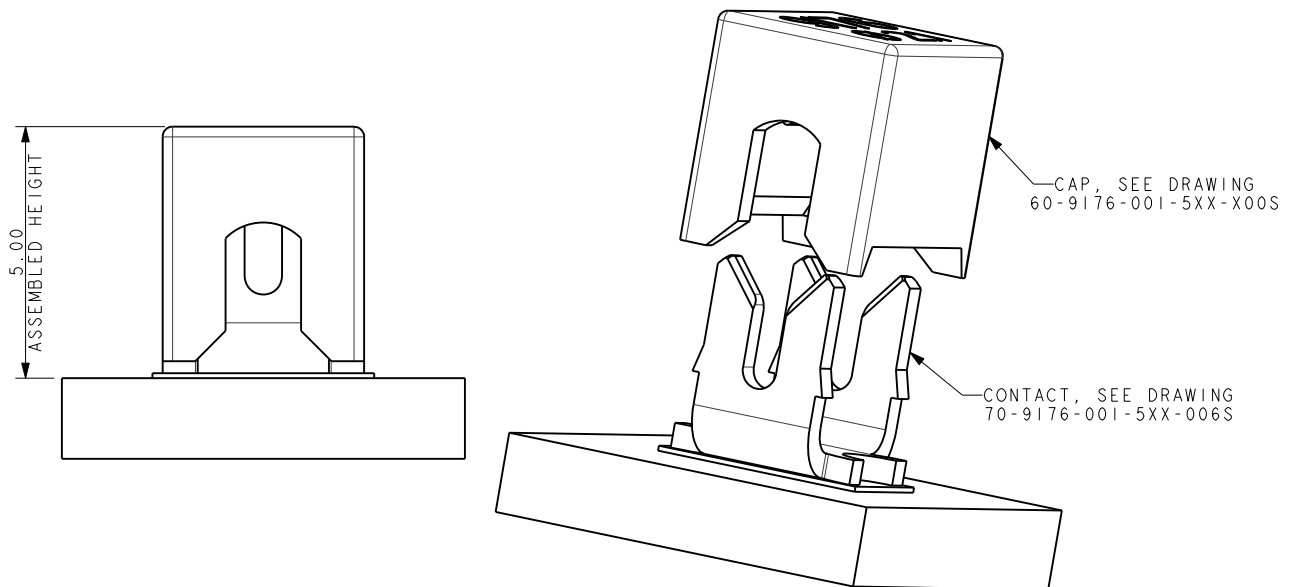

#### NOTES:

1. CONNECTOR CAN BE USED WITH CONTACT ONLY OR WITH OPTIONAL CAP.
2. OUTLINE OF CAP WHEN USED.
3. FOR FULL PRODUCT SPECIFICATION REFER TO ELCO SPEC 201-01-106 AND 201-01-124.
4. DIMENSIONS SHOWN ARE REFERENCED DIMENSIONS.
5. ASSEMBLY TOOLING ON PAGE 43 (WITH CAP AND WITHOUT CAP).

### ASSEMBLY TOOLING – CAP USED

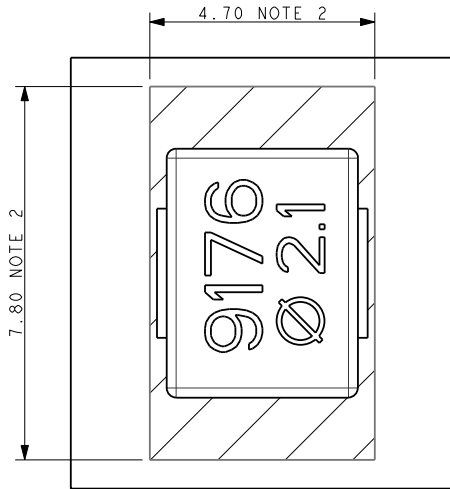

#### CAP APPLICATION TOOL

06-9176-7018-01-000

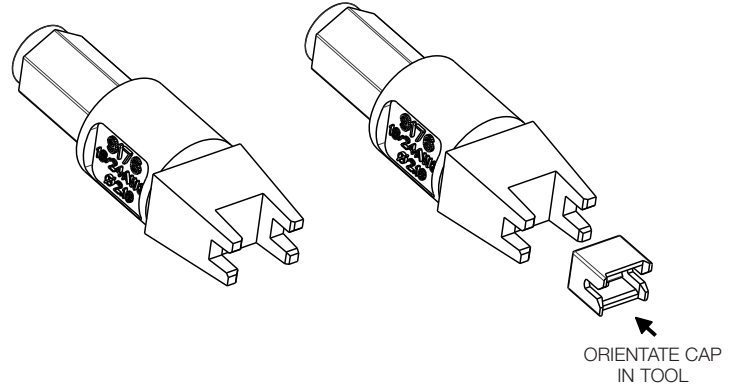

#### UNIVERSAL HANDLE

06 7000 7730 01 000

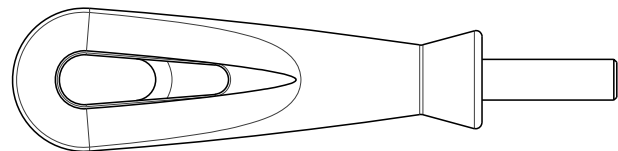

#### NOTES:

1. ASSEMBLY TOOLING FOR CAP.
2. AREA OF PCB TO BE KEPT CLEAR OF COMPONENTS, TACKS PERMISSIBLE.
3. WIRE AND CAP INSERTED IN ONE OPERATION.
4. REFER TO APPLICATION NOTE 201-01-124 FOR FURTHER INFORMATION.
5. REFER BELOW WHEN CONTACT USED WITHOUT CAP.

### ASSEMBLY TOOLING – CAP NOT USED WIRE ONTO CONTACT

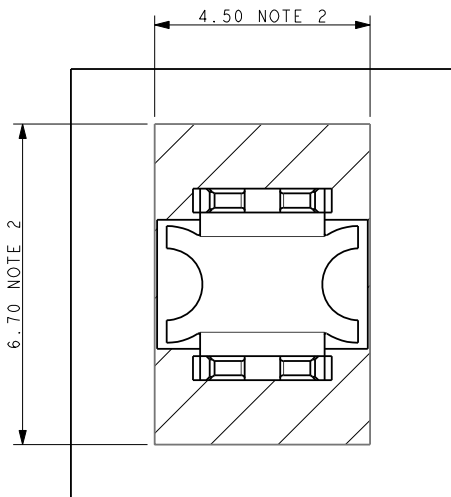

#### 2.1 WIRE (18-20 AWG)

06-9176-7019-01-000  
06-9176-7020-01-000

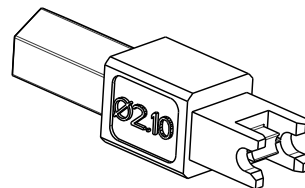

#### 1.6 WIRE (22-24 AWG)

06-9176-7019-02-000  
06-9176-7020-02-000

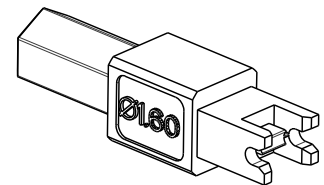

#### UNIVERSAL HANDLE

06 7000 7730 01 000

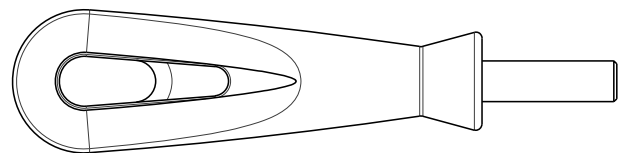

#### NOTES:

1. ASSEMBLY TOOLING FOR CONTACT ONLY, NO CAP USED.
2. MINIMUM AREA OF PCB TO BE KEPT CLEAR OF COMPONENTS, TRACK PERMISSIBLE.
3. REFER TO TABLE FOR CORRECT TOOL/WIRE COMBINATION.
4. REFER TO APPLICATION NOTE 201-01-124 FOR FURTHER INFORMATION.

Wire Gauge	Wire Insulation $\phi$	Metal Tool High Volume	Plastic Tool Small to Medium Volume	Handle
22-24 AWG	1.10 to 1.60	06-9176-7019-02-000	06-9176-7020-02-000	06-7000-7730-01-000
18-20 AWG	1.60 to 2.10	06-9176-7019-01-000	06-9176-7020-01-000	06-7000-7730-01-000

**CAP DETAILS**

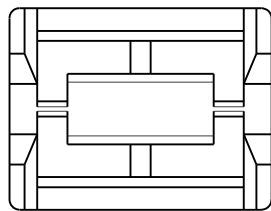
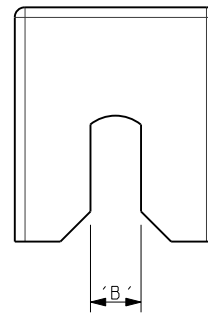
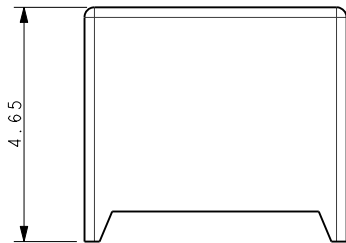
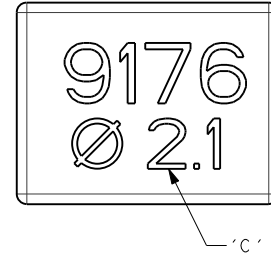
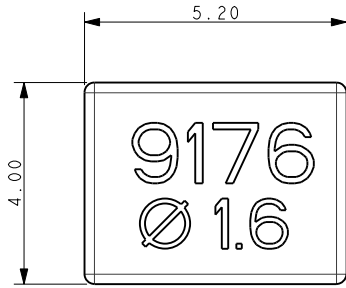

Code	Insulator Diameter (AWG)	B	Text C
516	1.1 to 1.6 (22-24)	1.00	Ø 1.6
521	1.6 to 2.1 (18-20)	1.50	Ø 2.1

**NOTES:**

1. CAP FOR IDC WIRE TO BOARD CONNECTION.
2. CAP MATERIAL: GLASS FILLED NYLON 46, COLOR SEE PAGE 40.
3. CAPS DESIGNED TO ACCOMMODATE WIRE INSULATION DIAMETERS 1.1MM TO 2.1MM.
4. ALL DIMENSIONS FOR REFERENCE UNLESS OTHERWISE STATED.
5. FOR FULL PRODUCT SPECIFICATION REFER TO ELCO SPEC 201-01-106, APPLICATION NOTES 201-01-124.
6. PACKING IN BAGS, QUANTITY 1000 PER BAG.
7. FOR INSTALATION DETAILS REFER TO DRAWING 70-9176-001-XX-006S.

# Standard 14-20 AWG: WTB

00-9177

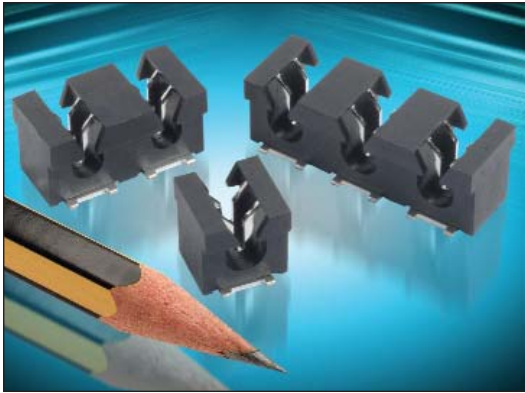

The 917X series of surface mount Insulation Displacement Connectors (IDC) were developed to meet the harsh automotive and industrial market applications for connecting individual wires directly to a PCB ranging from 14 AWG to 28 AWG. This industry proven contact system has been tested to automotive levels of shock, vibration, and temperature cycling to prove their reliability and robustness. The simplicity of inserting a wire into the connector with a small tool allows a wide range of devices to be connected to the PCB without soldering. In SSL applications specifically, these connectors are used to bring power and signal onto the PCB or are used to daisy chain multiple boards together in a long string. While the IDC contact provides a gas-tight connection to conductor of the wire, the housing has been designed to grab the insulation of the wire to provide a positive strain relief even in the harshest conditions. In case of repair, the wires can be removed and replaced up to three times.

The 9177 series accepts 14 AWG to 20 AWG wires with an insulation diameter ranging from 2.75mm to 4.25mm. These dual contact connectors support a 15 amp current rating with two large SMT solder tails per wire to provide maximum stability on the PCB. Available in 1p-3p configuration, these connectors can be end stackable for higher pin counts.

## APPLICATIONS

- Connecting discrete wire components directly to the PCB
- Bringing power and signals onto a PCB
- Daisy chaining PCB's together to create a continuous string of boards
- Application Notes: refer to 201-01-124

## FEATURES AND BENEFITS

- IDC contact provides a gas-tight connection to the PCB for long term reliability
- Connector housing captures the wire insulation for positive strain relief
- Tested to automotive levels on shock, vibration and temperature cycling for reliability
- Low and high volume assembly tools to match production volumes
- Reduced total applied cost versus solder or crimp processes
- High temperature insulator capable to 260°C reflow soldering processes

## ELECTRICAL

- Current Rating: 15 Amp / Contact
- Voltage Rating: 600 VAC

## ENVIRONMENTAL

- Operating Temperature: -40°C to +125°C

## MECHANICAL

- Insulator Material: Nylon 46: UL94V0
- Contact Material: Phosphor Bronze
- Plating: Tin over Nickel
- Durability: 3 Cycles

## HOW TO ORDER

<b>00</b>	<b>9177</b>	<b>00X</b>	<b>0XX</b>	<b>X</b>	<b>06</b>	
Prefix	Series	Number of Ways	Wire Gauge Size	Color/Approval	Plating Option	

Code	No of Ways	Details
001	1	Page 47
002	2	Page 48
003	3	Page 49

Code	Accepted Wire Gauge	Wire Insulation
001	14 AWG Solid or Stranded	Ø 4.25
012	16 AWG Solid or Stranded	Ø 3.50
022	18 AWG Solid or Stranded	Ø 3.50
033	20 AWG Solid or Stranded	Ø 2.75

Code	Color	Approval
0	Black	Special Order
1	White	Standard
9	White	UL Approved
8	Black	UL Approved Special Order

06 = Pure Tin all over

## HOW TO ORDER – CAP OPTIONS – THROUGH WIRE

<b>60</b>	<b>9177</b>	<b>00X</b>	<b>0XX</b>	<b>X00</b>
Prefix	Series	Number of Ways	Wire Gauge Size	Insulator Color

60 = Cap

Code	No of Ways
001	1
002	2
003	3

Code	Wire Insulator Diameter (Note 3)	A	B
027	2.10mm - 2.75mm	Ø2.75	2.00
035	2.75mm - 3.50mm	Ø3.50	2.65
042	3.50mm - 4.25mm	Ø4.25	3.40

Code	Color
000	Black
100	White

## HOW TO ORDER – CAP OPTIONS – WIRE STOP

<b>60</b>	<b>9177</b>	<b>00X</b>	<b>0XX</b>	<b>X99</b>
Prefix	Series	Number of Ways	Wire Gauge Size	Insulator Color

60 = Cap

Code	No of Ways
001	1
002	2
003	3

Code	Wire Insulator Diameter (Note 3)	A	B
027	2.10mm - 2.75mm	Ø2.75	2.00
035	2.75mm - 3.50mm	Ø3.50	2.65
042	3.50mm - 4.25mm	Ø4.25	3.40

Code	Color
099	Black
199	White

Certification:  
UL File # E320991,  
check UL conditions of use for  
specific ratings and details

# Standard 14-20 AWG: WTB

00-9177



## CONNECTOR/TOOLING PART NUMBER MATRIX

AWG	Wire Insulation	SERIES 9177 IDC			HAND INSERTION TOOLING*		ACCESSORY CAPS	
		Positions	Color	Part Number	Plastic (low volume)	Metal (high volume)	Through Wire	Wire Stop
14	Ø 4.25	1p	White	009177001001106	069177701601001	069177701701001	609177001042100	609177001042199
14	Ø 4.25	1p	Black	009177001001006	069177701601001	069177701701001	609177001042000	609177001042099
14	Ø 4.25	2p	White	009177002001106	069177701601002	069177701701002	609177002042100	609177002042199
14	Ø 4.25	2p	Black	009177002001006	069177701601002	069177701701002	609177002042000	609177002042099
14	Ø 4.25	3p	White	009177003001106	069177701601003	069177701701003	609177003042100	609177003042199
14	Ø 4.25	3p	Black	009177003001006	069177701601003	069177701701003	609177003042000	609177003042099
16	Ø 3.50	1p	White	009177001012106	069177701602001	069177701702001	609177001035100	609177001035199
16	Ø 3.50	1p	Black	009177001012006	069177701602001	069177701702001	609177001035000	609177001035099
16	Ø 3.50	2p	White	009177002012106	069177701602002	069177701702002	609177002035100	609177002035199
16	Ø 3.50	2p	Black	009177002012006	069177701602002	069177701702002	609177002035000	609177002035099
16	Ø 3.50	3p	White	009177003012106	069177701602003	069177701702003	609177003035100	609177003035199
16	Ø 3.50	3p	Black	009177003012006	069177701602003	069177701702003	609177003035000	609177003035099
18	Ø 3.50	1p	White	009177001022106	069177701602001	069177701702001	609177001035100	609177001035199
18	Ø 3.50	1p	Black	009177001022006	069177701602001	069177701702001	609177001035000	609177001035099
18	Ø 3.50	2p	White	009177002022106	069177701602002	069177701702002	609177002035100	609177002035199
18	Ø 3.50	2p	Black	009177002022006	069177701602002	069177701702002	609177002035000	609177002035099
18	Ø 3.50	3p	White	009177003022106	069177701602003	069177701702003	609177003035100	609177003035199
18	Ø 3.50	3p	Black	009177003022006	069177701602003	069177701702003	609177003035000	609177003035099
20	Ø 2.75	1p	White	009177001033106	069177701603001	069177701703001	609177001027100	609177001027199
20	Ø 2.75	1p	Black	009177001033006	069177701603001	069177701703001	609177001027000	609177001027099
20	Ø 2.75	2p	White	009177002033106	069177701603002	069177701703002	609177002027100	609177002027199
20	Ø 2.75	2p	Black	009177002033006	069177701603002	069177701703002	609177002027000	609177002027099
20	Ø 2.75	3p	White	009177003033106	069177701603003	069177701703003	609177003027100	609177003027199
20	Ø 2.75	3p	Black	009177003033006	069177701603003	069177701703003	609177003027000	609177003027099

\* Insertion Tooling - Requires Hand Press with Flat Rock Plates; Consult Application Notes 201-01-124



### 14-20 AWG 1 WAY IDC CONNECTOR

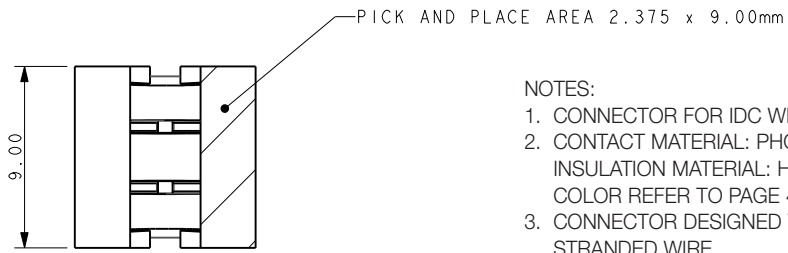

**NOTES:**

1. CONNECTOR FOR IDC WIRE TO BOARD CONNECTION.
2. CONTACT MATERIAL: PHOSPHOR BRONZE.  
INSULATION MATERIAL: HIGH TEMPERATURE NYLON 46.  
COLOR REFER TO PAGE 45.
3. CONNECTOR DESIGNED TO ACCEPT BETWEEN 14 AND 20 GAUGE STRANDED WIRE.
4. ALL DIMENSIONS FOR REFERENCE UNLESS OTHERWISE STATED.
5. FOR FULL PRODUCT SPECIFICATION REFER TO ELCO SPEC 201-01-109.
6. FOR PCB SPACE RESTRICTED BY ASSEMBLY TOOLING REFER TO PAGE 52.

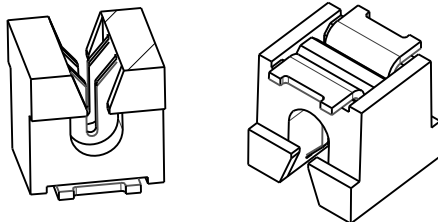
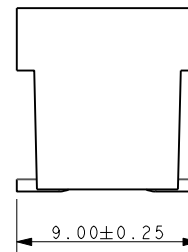
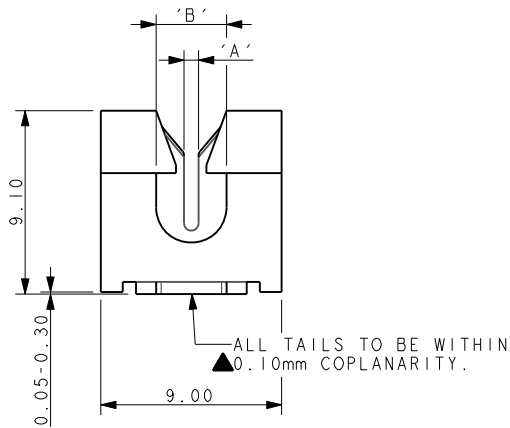

Code	Accepted Wire Gauge	A	Wire Insulation	B
001	14 AWG Solid or Stranded	1.10	Ø 4.25 max	4.25
012	16 AWG Solid or Stranded	0.82	Ø 3.50 max	3.50
022	18 AWG Solid or Stranded	0.72	Ø 3.50 max	3.50
033	20 AWG Solid or Stranded	0.60	Ø 2.75 max	2.75

### SMT PCB LAYOUT

PURE TIN PADS

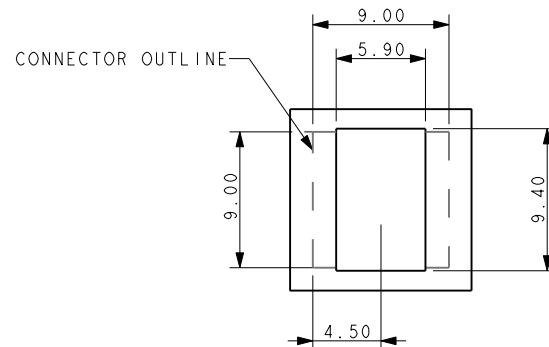

### PACKING DETAILS

REEL QTY	400
LEADER	500MM
TRAILER	400MM
REEL/BOX	4
PACK QTY	1600

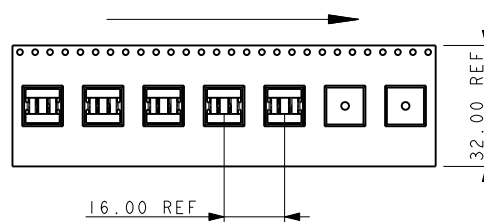
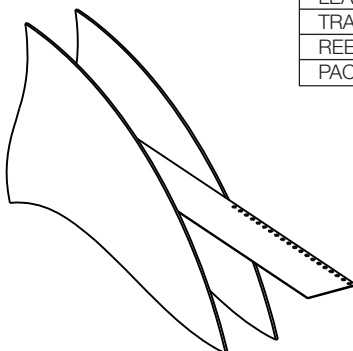



### 14-20 AWG 2 WAY IDC CONNECTOR

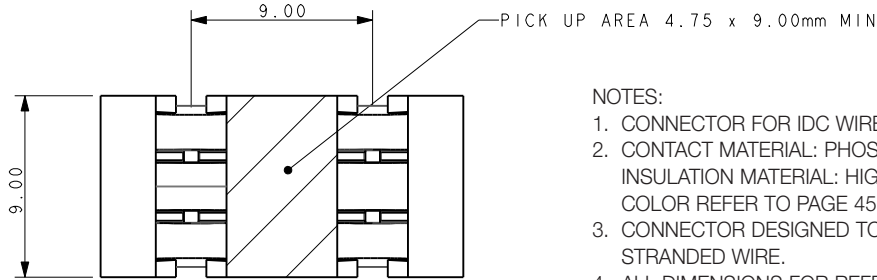

**NOTES:**

1. CONNECTOR FOR IDC WIRE TO BOARD CONNECTION.
2. CONTACT MATERIAL: PHOSPHOR BRONZE.  
INSULATION MATERIAL: HIGH TEMPERATURE NYLON 46.  
COLOR REFER TO PAGE 45.
3. CONNECTOR DESIGNED TO ACCEPT BETWEEN 14 AND 20 GAUGE STRANDED WIRE.
4. ALL DIMENSIONS FOR REFERENCE UNLESS OTHERWISE STATED.
5. FOR FULL PRODUCT SPECIFICATION REFER TO ELCO SPEC 201-01-109.
6. FOR PCB SPACE RESTRICTED BY ASSEMBLY TOOLING REFER TO PAGE 52.

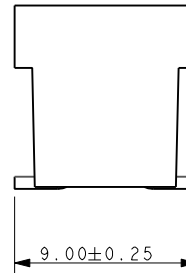
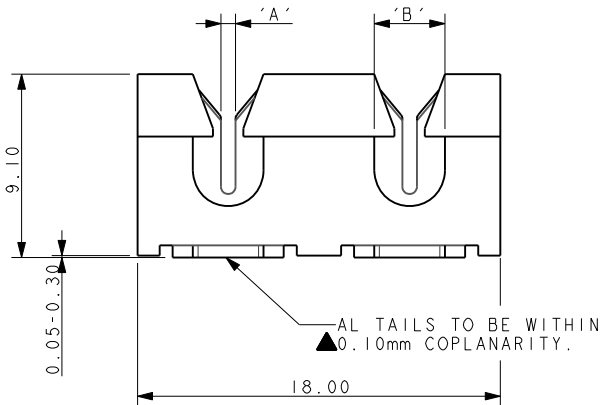

Code	Accepted Wire Gauge	A	Wire Insulation	B
001	14 AWG Solid or Stranded	1.10	Ø 4.25 max	4.25
012	16 AWG Solid or Stranded	0.82	Ø 3.50 max	3.50
022	18 AWG Solid or Stranded	0.72	Ø 3.50 max	3.50
033	20 AWG Solid or Stranded	0.60	Ø 2.75 max	2.75

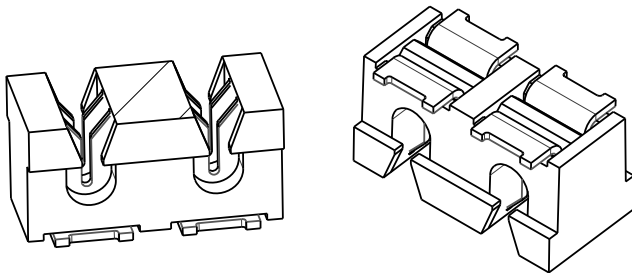

### SMT PCB LAYOUT PURE TIN PADS

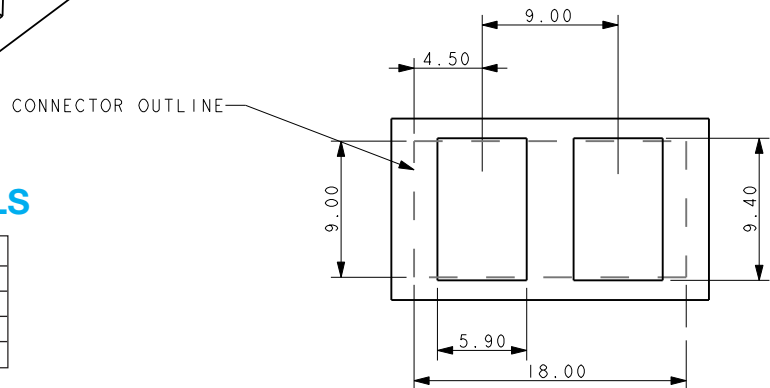

### PACKING DETAILS

REEL QTY	400
LEADER	500MM
TRAILER	400MM
REEL/BOX	4
PACK QTY	1600

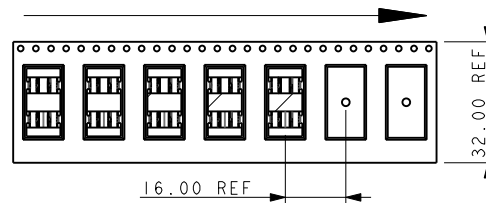
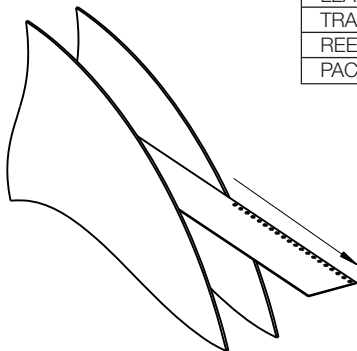

### 14-20 AWG 3 WAY IDC CONNECTOR

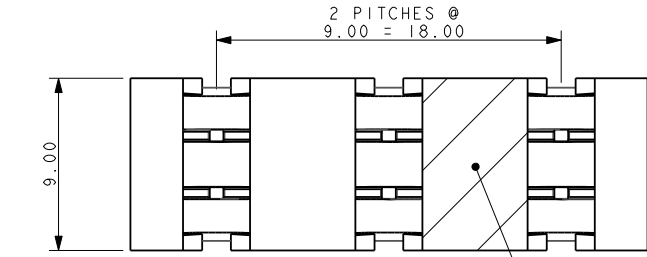

**NOTES:**

1. CONNECTOR FOR IDC WIRE TO BOARD CONNECTION.
2. CONTACT MATERIAL: PHOSPHOR BRONZE.  
INSULATION MATERIAL: HIGH TEMPERATURE NYLON 46.  
COLOR REFER TO PAGE 45.
3. CONNECTOR DESIGNED TO ACCEPT BETWEEN 14 AND 20 GAUGE STRANDED WIRE.
4. ALL DIMENSIONS FOR REFERENCE UNLESS OTHERWISE STATED.
5. FOR FULL PRODUCT SPECIFICATION REFER TO ELCO SPEC 201-01-109.
6. FOR PCB SPACE RESTRICTED BY ASSEMBLY TOOLING REFER TO PAGE 52.

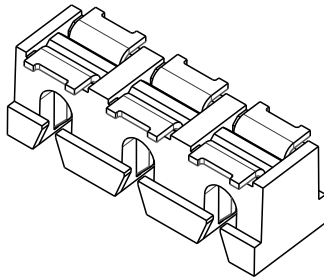
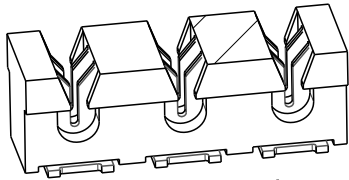
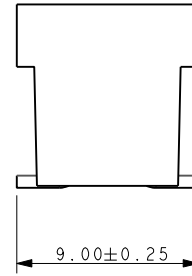
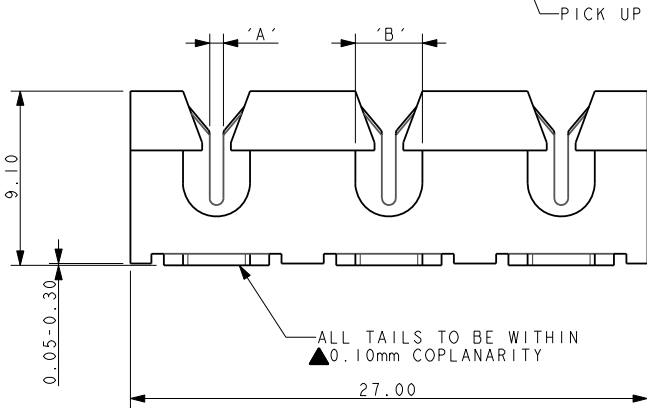

Code	Accepted Wire Gauge	A	Wire Insulation	B
001	14 AWG Solid or Stranded	1.10	Ø 4.25 max	4.25
012	16 AWG Solid or Stranded	0.82	Ø 3.50 max	3.50
022	18 AWG Solid or Stranded	0.72	Ø 3.50 max	3.50
033	20 AWG Solid or Stranded	0.60	Ø 2.75 max	2.75

### SMT PCB LAYOUT

PURE TIN PADS

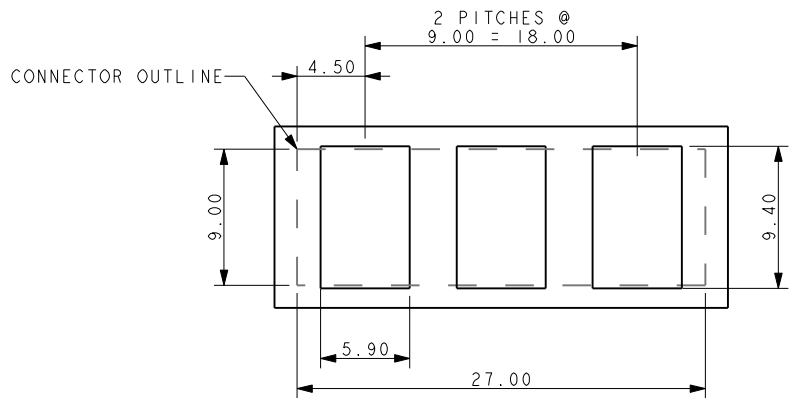

### PACKING DETAILS

REEL QTY	400
LEADER	500MM
TRAILER	400MM
REEL/BOX	4
PACK QTY	1600

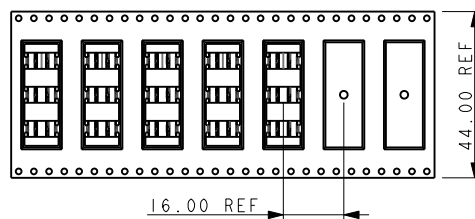
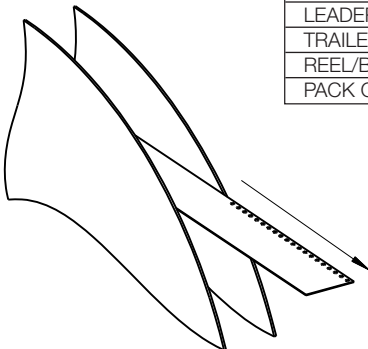

### ACCESSORY CAP – THROUGH WIRE

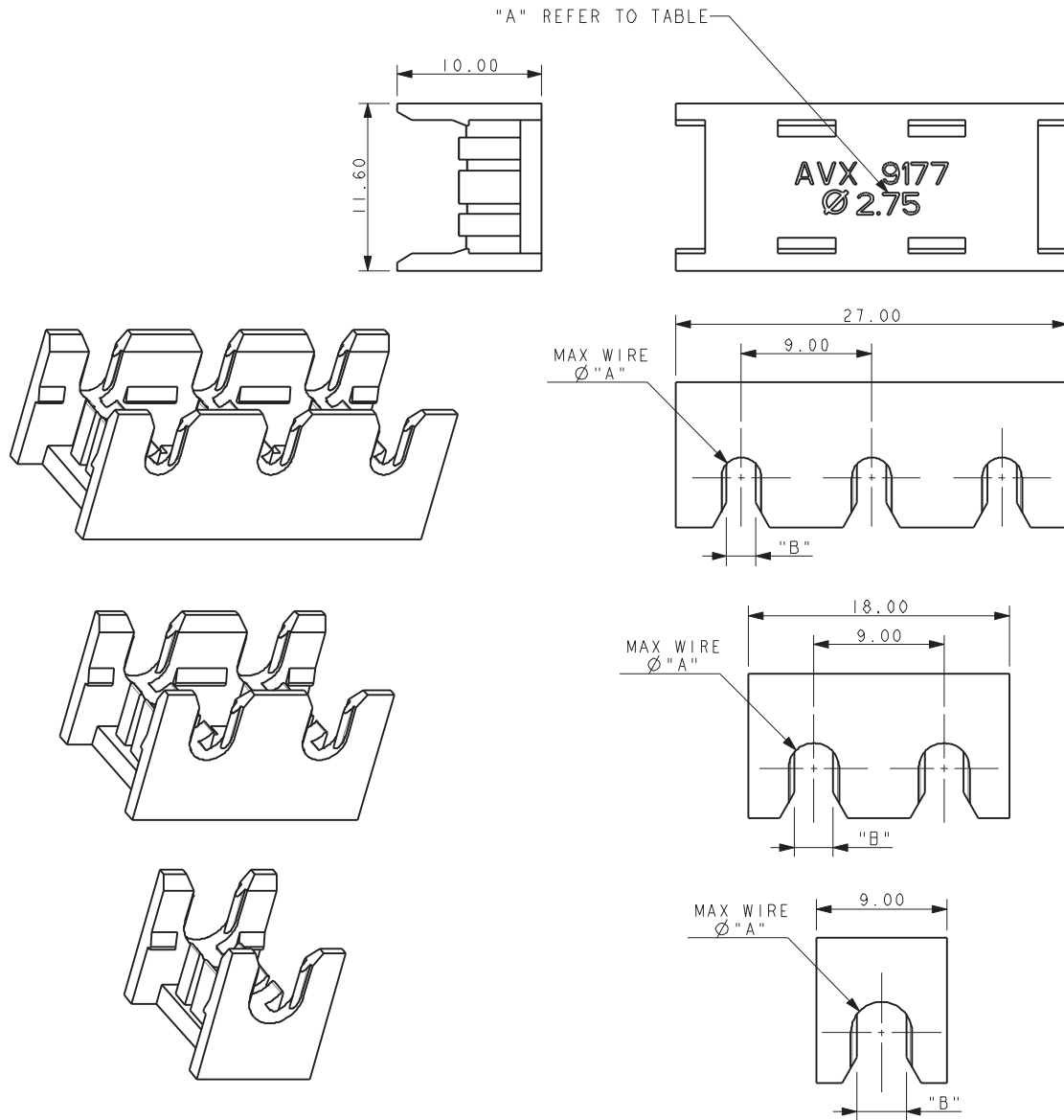

**NOTES:**

1. CAP FOR 9177 IDC WIRE TO BOARD CONNECTOR.
2. THROUGH WIRE CAP CAN BE USED AT ANY POSITION ALONG WIRE.
3. REFERS TO CAP, FOR WIRE MATCH TO CONNECTOR REFER TO TABLE ON PAGE 45.
4. MATERIAL: GLASS FILLED NYLON 46. FOR COLOR REFER TO PAGE 45.
5. CAPS DESIGNED TO ACCOMMODATE INSULATION DIAMETERS REFER TO PAGE 45.
6. GENERAL TOLERANCE  $\pm 0.20\text{MM}$ .
7. PACKED IN BAGS, 400 PIECES PER BAG.
8. APPLICATION NOTES REFER TO ELCO SPECIFICATION 201-01-124.

### ACCESSORY CAP – WIRE STOP

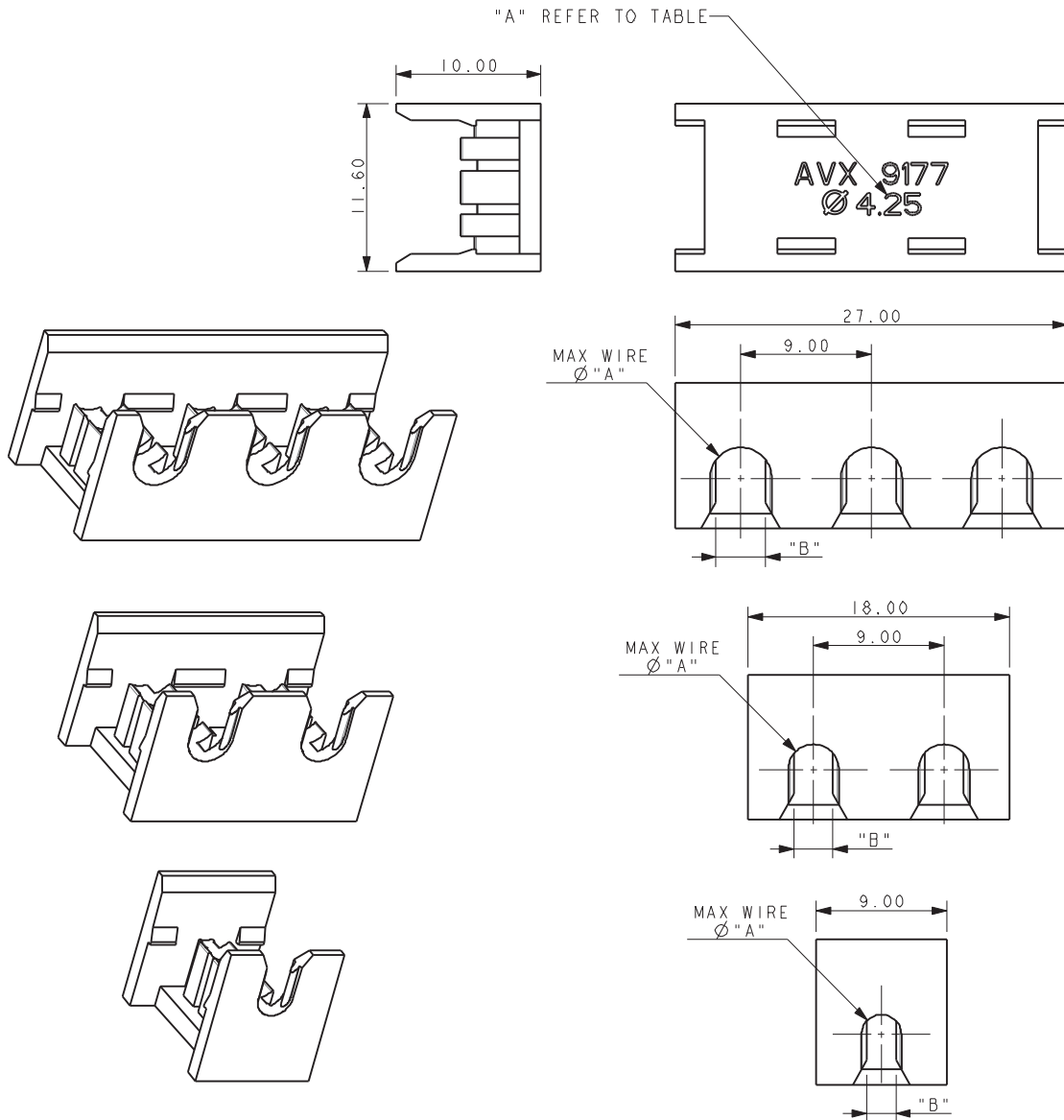

**NOTES:**

1. CAP FOR 9177 IDC WIRE TO BOARD CONNECTOR.
2. THROUGH WIRE CAP CAN BE USED AT ANY POSITION ALONG WIRE.
3. REFERS TO CAP, FOR WIRE MATCH TO CONNECTOR REFER TO TABLE ON PAGE 45.
4. MATERIAL: GLASS FILLED NYLON 46. FOR COLOR REFER TO PAGE 45.
5. CAPS DESIGNED TO ACCOMMODATE INSULATION DIAMETERS REFER TO PAGE 45.
6. GENERAL TOLERANCE  $\pm 0.20\text{MM}$ .
7. PACKED IN BAGS, 400 PIECES PER BAG.
8. APPLICATION NOTES REFER TO ELCO SPECIFICATION 201-01-124.

### INSERTION TOOLING – REQUIRES HAND PRESS WITH FLAT ROCK PLATES

1 WAY

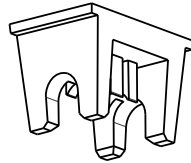

2 WAY

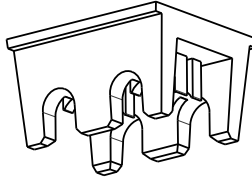

3 WAY

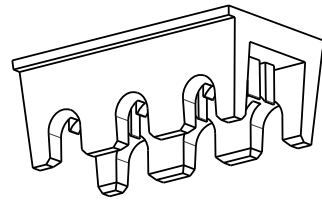

#### HIGH PRODUCTION Metal

No. of Ways	Max Insulation Dia (AWG)	Tool Part Number
1	4.25 (14)	06 9177 7017 01 001
	3.50 (16-18)	06 9177 7017 02 001
	2.75 (20)	06 9177 7017 03 001
2	4.25 (14)	06 9177 7017 01 002
	3.50 (16-18)	06 9177 7017 02 002
	2.75 (20)	06 9177 7017 03 002
3	4.25 (14)	06 9177 7017 01 003
	3.50 (16-18)	06 9177 7017 02 003
	2.75 (20)	06 9177 7017 03 003

#### MEDIUM PRODUCTION Plastic

No. of Ways	Max Insulation Dia (AWG)	Tool Part Number
1	4.25 (14)	06 9177 7016 01 001
	3.50 (16-18)	06 9177 7016 02 001
	2.75 (20)	06 9177 7016 03 001
2	4.25 (14)	06 9177 7016 01 002
	3.50 (16-18)	06 9177 7016 02 002
	2.75 (20)	06 9177 7016 03 002
3	4.25 (14)	06 9177 7016 01 003
	3.50 (16-18)	06 9177 7016 02 003
	2.75 (20)	06 9177 7016 03 003

The assembly tooling restricts the available space/component heights on the PCB.  
For details see below.

NOTES:

1. ALL DIMENSIONS FOR REFERENCE DIMENSIONS.
2. MAXIMUM COMPONENT HEIGHT 0.80MM IN THIS AREA.
3. MAXIMUM COMPONENT HEIGHT 11.00 MM IN THIS AREA.
4. THE SAME RESTRICTIONS APPLY TO ALL WIRE INSULATION DIAMETERS.

### INSERTION TOOLING – PCB RESTRICTED AREAS FOR ASSEMBLY TOOLING

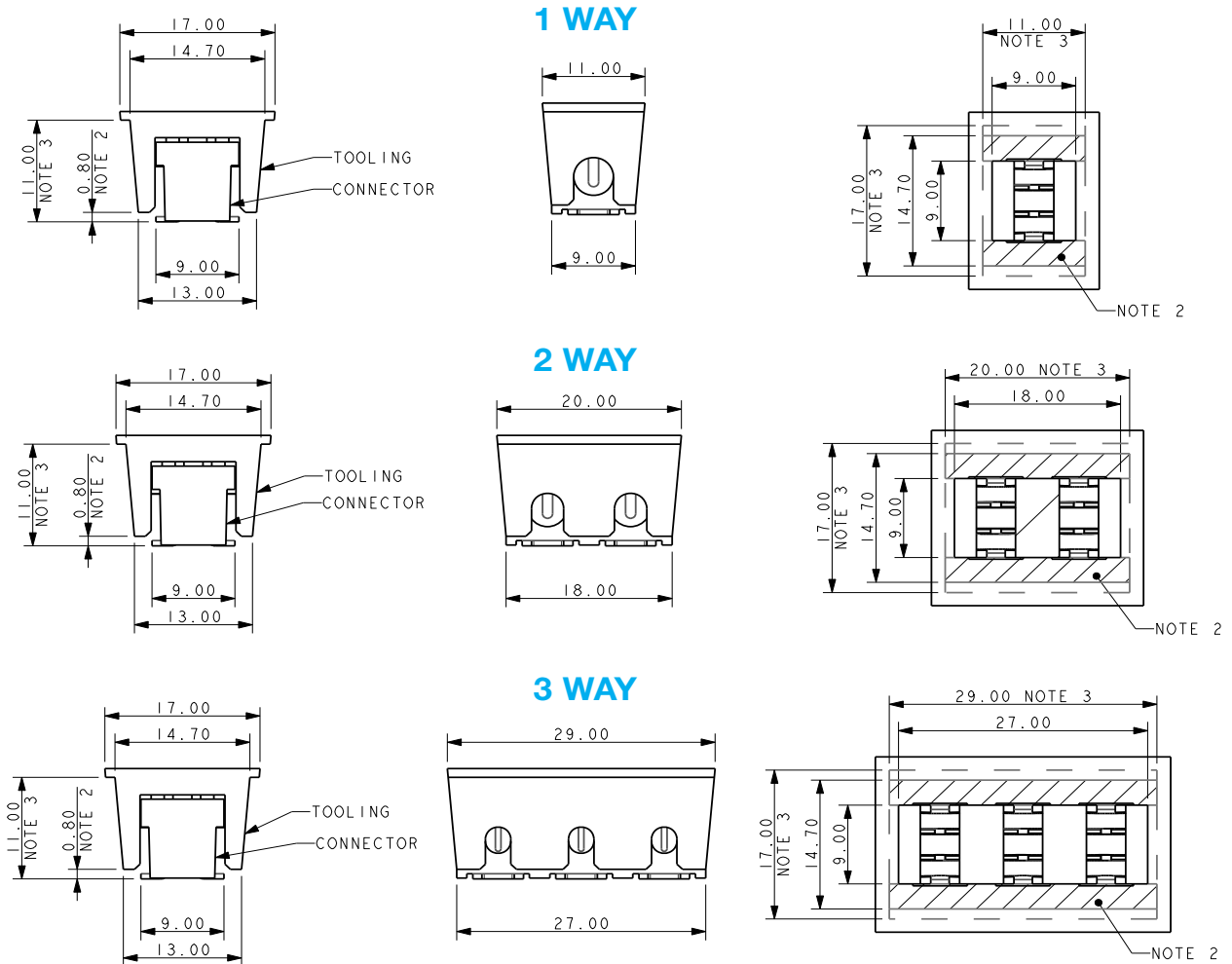

# Capped Thru Hole 12-18 AWG: WTB

00-9177



AVX developed the initial SMT discrete wire IDC connector 5 years ago for 26-28AWG AVX wires. Since then, we have seen this Wire-to-Board (WTB) contact technology spread to multiple wire gauges and multiple configurations; standard connectors, capped connectors and single contacts. All of which addresses specific application or cost parameters set forth by our customer in demanding industrial, transportation or commercial applications. The heart of the IDC connector is the true “gas tight” WTB termination that is achieved once the wire is inserted between the dual phosphor bronze contact tines. These opposing tines provide enough spring characteristics to allow the termination to remain stable over extreme levels of temperature, shock and vibration.

The new 9177-600 family of contacts incorporates all of the above mentioned capabilities. From low cost single contacts to fully integrated capped contacts. The unique feature of the 600 series is the fact that it was developed for Plated Through Hole (PTH) termination to the PCB. This addresses the rugged power type boards that have to handle larger wire gauges up to 12AWG and 15 Amps per contact of current. The PTH option provides robust PCB attachment and high current capabilities to replace older technology connectors or in most cases soldering stripped wires directly to the PCB.

## APPLICATIONS

- Industrial pumps, motors and driver boards
- Solar and alternative energy products
- Commercial electrical equipment
- Reference Product Specification & application notes 201-01-141/142

## FEATURES AND BENEFITS

- IDC contact provides a “gas tight” wire termination to the PCB to meet harsh industrial environments
- Simple, robust design offers a high performance solution to hand soldering large gauge wires to a PCB
- A single contact can handle up to 15A for high current applications with wire replacement up to 3 times
- The versatile family of IDC contact can accept 12-18AWG of stranded wires and can be tested for compliance with solid wires

## ELECTRICAL

- Current Rating: 15A
- Voltage Rating: 600 VAC

## ENVIRONMENTAL

- Operating Temperature: -40°C to +125°C

## MECHANICAL

- Insulator Material: Nylon 46, UL94VO
- Contact Material: Phosphor Bronze
- Plating: Tin over Nickel
- Durability: Wires can be replaced up to 3 time

## HOW TO ORDER

00 9177 00X  
Prefix Series Number of Ways

Code	No of Ways	Details
001	1	Page 55

6XX

Wire Insulation/Gauge Size

Code	Style	Accepted Wire Gauge	Wire Insulation
691	Though Hole Mount	12 AWG Solid or Stranded	Ø 4.25 Max
601	Though Hole Mount	14 AWG Solid or Stranded	Ø 4.25 Max
612	Though Hole Mount	16 AWG Solid or Stranded	Ø 3.50 Max
622	Though Hole Mount	18 AWG Solid or Stranded	Ø 3.50 Max

XX

Color & Type

Code	Insulator Color	Cap Type	Description
00	Black - Special Order	Through Wire	Any Position Along Wire
09	Black - Special Order	Wire Stop	End of Wire - Includes Stop
10	White - Standard	Through Wire	Any Position Along Wire
19	White - Standard	Wire Stop	End of Wire - Includes Stop

6

Plating Option  
6 = Pure Tin all over



### 12 - 18 AWG 1 WAY IDC CONNECTOR WIRE THROUGH CAP

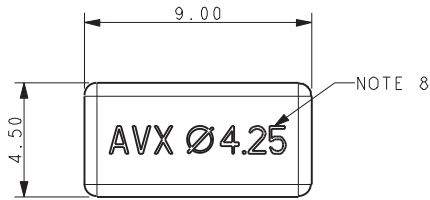

**NOTES:**

1. CONNECTOR FOR IDC WIRE TO BOARD CONNECTION, WIRE THROUGH CAP, CAN BE ASSEMBLED AT ANY POSITION ALONG A WIRE.
2. CONTACT MATERIAL: PHOSPHOR BRONZE. INSULATION MATERIAL: HIGH TEMP NYLON 46, UL94 V-0. COLOR REFER TO PAGE 53.
3. CONNECTOR DESIGNED TO ACCEPT BETWEEN 12 AND 18 AWG STRANDED WIRE.
4. ALL DIMENSIONS  $\pm 0.20$  UNLESS TOLERANCED.
5. FOR FULL PRODUCT SPECIFICATION ON STANDARD CONNECTORS REFER TO ELCO SPEC 201-01-141.
6. APPLICATION NOTES 201-01-142.
7. OUTLINE OF CAP. NO SPACE FOR COMPONENTS.
8. TEST TO INDICATE MAXIMUM INSULATION DIAMETER.

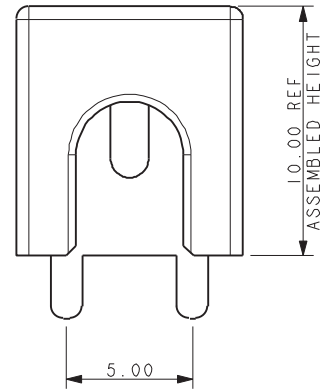
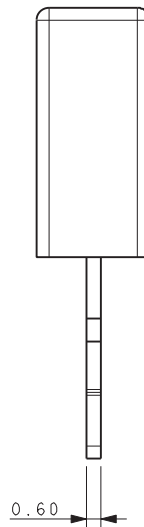
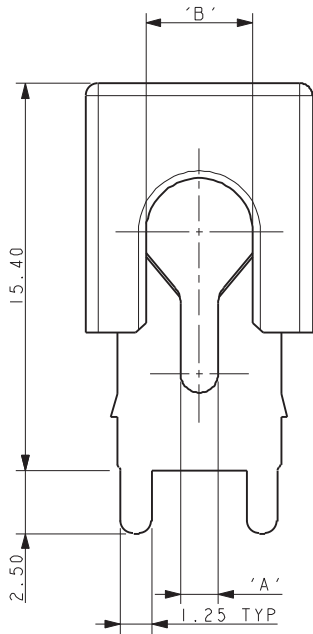

### PACKING DETAILS



330mm DIAMETER REEL

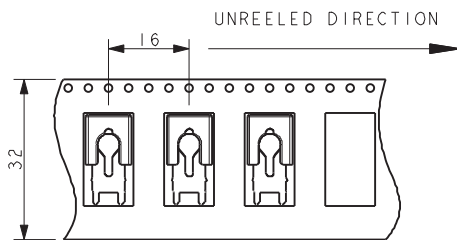

QUANTITY PER REEL 800

Code	Accepted Wire Gauge	A	Wire Insulation	B
691	12 AWG Solid or Stranded	1.50	Ø 4.25 Max	4.25
601	14 AWG Solid or Stranded	1.10	Ø 4.25 Max	4.25
612	16 AWG Solid or Stranded	0.82	Ø 3.50 Max	3.50
622	18 AWG Solid or Stranded	0.72	Ø 3.50 Max	3.50

### SMT PCB LAYOUT

PURE TIN PADS

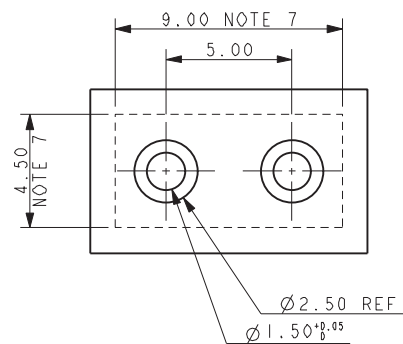

### 12 - 18 AWG 1 WAY IDC CONNECTOR WIRE STOP CAP

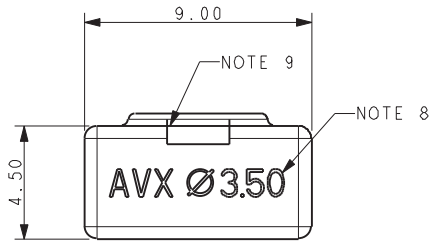

**NOTES:**

1. CONNECTOR FOR IDC WIRE TO BORAD CONNECTION, WIRE STOP CAP, FOR USE AT WIRE END.
2. CONTACT MATERIAL: PHOSPHOR BRONZE. INSULATION MATERIAL: HIGH TEMP NYLON 46, UL94 V-0. COLOR REFER TO PAGE 53.
3. CONNECTOR DESIGNED TO ACCEPT BETWEEN 12 AND 18 AWG STRANDED WIRE.
4. ALL DIMENSIONS  $\pm 0.20$  UNLESS TOLERANCED.
5. FOR FULL PRODUCT SPECIFICATION ON STANDARD CONNECTORS REFER TO ELCO SPEC 201-01-141.
6. APPLICATION NOTES 201-01-142.
7. OUTLINE OF CAP. NO SPACE FOR COMPONENTS.
8. TEST TO INDICATE MAXIMUM INSULATION DIAMETER.
9. SLOT TO CHECK WIRE POSITION BEFORE ASSEMBLY.

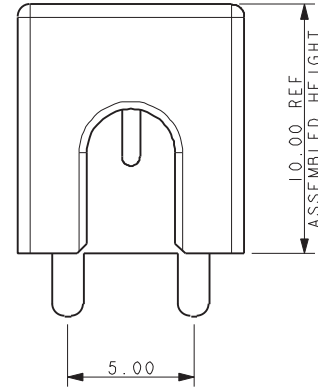
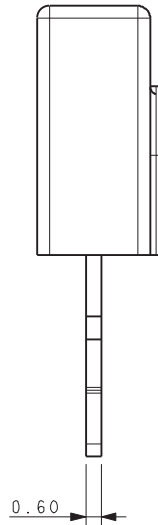
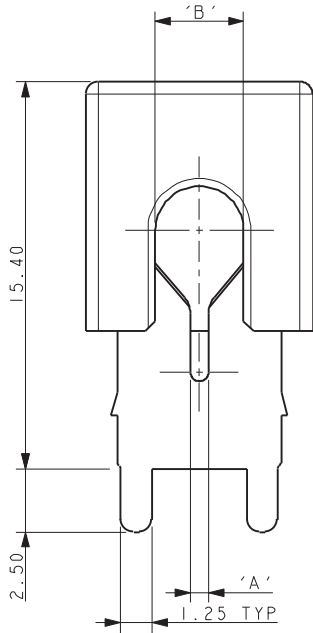

### PACKING DETAILS



330mm DIAMETER REEL

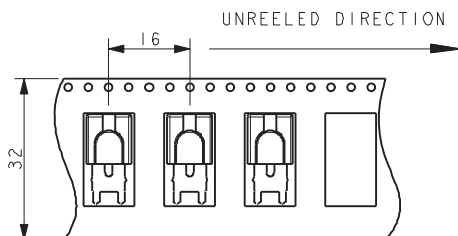

Code	Accepted Wire Gauge	A	Wire Insulation	B
691	12 AWG Solid or Stranded	1.50	Ø 4.25 Max	4.25
601	14 AWG Solid or Stranded	1.10	Ø 4.25 Max	4.25
612	16 AWG Solid or Stranded	0.82	Ø 3.50 Max	3.50
622	18 AWG Solid or Stranded	0.72	Ø 3.50 Max	3.50

### SMT PCB LAYOUT

PURE TIN PADS

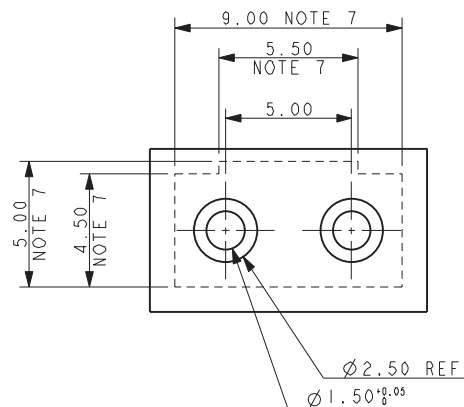



# Single Thru Hole IDC Contact

## 12-18 AWG: WTB

9177-600



AVX developed the initial SMT discrete wire IDC connector 5 years ago for 26-28AWG AVX wires. Since then, we have seen this Wire-to-Board (WTB) contact technology spread to multiple wire gauges and multiple configurations; standard connectors, capped connectors and single contacts. All of which addresses specific application or cost parameters set forth by our customer in demanding industrial, transportation or commercial applications. The heart of the IDC connector is the true “gas tight” WTB termination that is achieved once the wire is inserted between the dual phosphor bronze contact tines. These opposing tines provide enough spring characteristics to allow the termination to remain stable over extreme levels of temperature, shock and vibration.

The new 9177-600 family of contacts incorporates all of the above mentioned capabilities. From low cost single contacts to fully integrated capped contacts. The unique feature of the 600 series is the fact that it was developed for Plated Through Hole (PTH) termination to the PCB. This addresses the rugged power type boards that have to handle larger wire gauges up to 12AWG and 15 Amps per contact of current. The PTH option provides robust PCB attachment and high current capabilities to replace older technology connectors or in most cases soldering stripped wires directly to the PCB.

### APPLICATIONS

- Industrial pumps, motors and driver boards
- Solar and alternative energy products
- Commercial electrical equipment
- Reference Product Specification & application notes 201-01-141/142

### FEATURES AND BENEFITS

- IDC contact provides a “gas tight” wire termination to the PCB to meet harsh industrial environments
- Simple, robust design offers a high performance solution to hand soldering large gauge wires to a PCB
- A single contact can handle up to 15A for high current applications with wire replacement up to 3 times
- The versatile family of IDC contact can accept 12-18AWG of stranded wires and can be tested for compliance with solid wires

### ELECTRICAL

- Current Rating: 15A
- Voltage Rating: 600 VAC

### ENVIRONMENTAL

- Operating Temperature: -40°C to +125°C

### MECHANICAL

- Insulator Material: Nylon 46, UL94VO
- Contact Material: Phosphor Bronze
- Plating: Tin over Nickel
- Durability: Wires can be replaced up to 3 time

### HOW TO ORDER – CONTACT OPTIONS

**70**  
Prefix  
70 = Contact

**9177**  
Series

**001**  
Number of Ways

Code	No of Ways	Details
001	1	Page 57

**6XX**  
Wire Gauge Size

Code	Accepted Wire Gauge
691	12 AWG Solid or Stranded
601	14 AWG Solid or Stranded
612	16 AWG Solid or Stranded
622	18 AWG Solid or Stranded

**006**  
Plating Option  
006 = Pure Tin all over



### HOW TO ORDER – CAP OPTIONS

**60**  
Prefix  
60 = Cap

**9177**  
Series

**001**  
Number of Ways

Code	No of Ways	Details
001	1	Pages 58-59

**6XX**  
Wire Insulation Diameter

Code	Wire Insulation (AWG)	Diameter “A”
627	Ø 2.10 - 2.75	2.75
635	Ø 2.75 - 3.50	3.50
642	Ø 3.50 - 4.25	4.25

**X**  
Color Options

Code	Color	Application
0	Black	Special Order
1	White	Standard

**XX**  
Assembly Options

Code	Description
00	Through Wire
99	With Stop

# Single Thru Hole IDC Contact

## 12-18 AWG: WTB

9177-600

### 70-9177-001-6XX-006

### CONTACT DETAILS

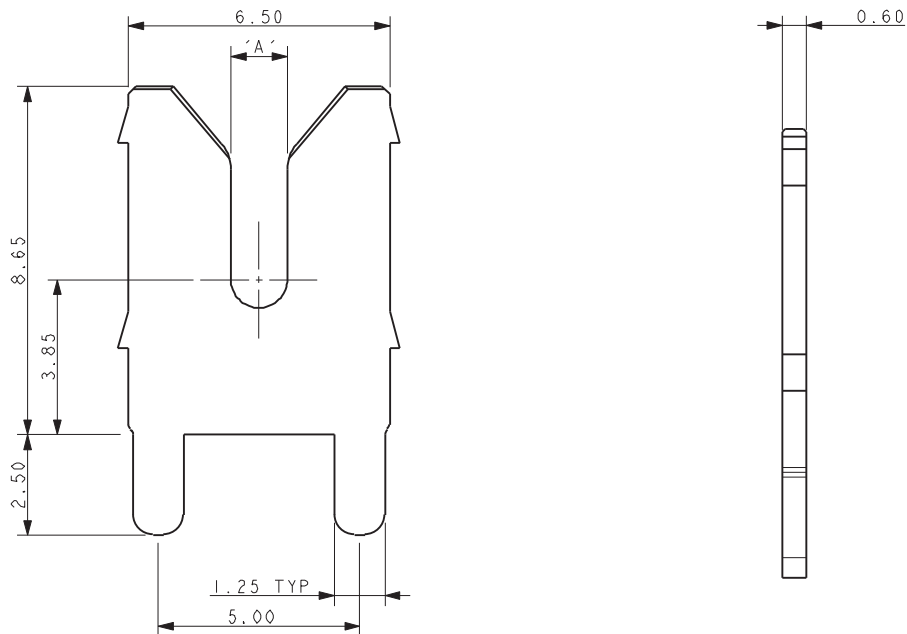

### PCB LAYOUT FOR CONTACT

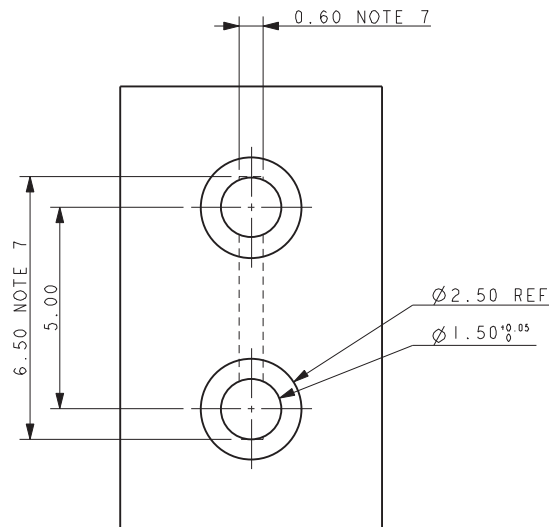

Code	Accepted Wire Gauge	A
691	12 AWG Solid or Stranded	1.50
601	14 AWG Solid or Stranded	1.10
612	16 AWG Solid or Stranded	0.82
622	18 AWG Solid or Stranded	0.72

NOTES:

1. IDC CONTACT OT ACCEPT WIRES FROM 12 AWG TO 18 AWG.
2. MATERIAL: PHOSPHOR BRONZE.
3. PLATING PURE TIN OVER NICKEL.
4. ALL DIMENSIONS  $\pm 0.20$  UNLESS SPECIFIED.
5. PACKING IN BAGS, 800 PIECES PER BAG.
6. PRODUCT SPECIFICATION REFER TO 201-01-141.
7. OUTLINE OF CONTACT SEE PAGE 56 FOR ADDITIONAL CLEARANCE REQUIRED FOR WIRE INSERTION TOOL.
8. FOR ASSEMBLY DETAILS REFER TO APPLICATION NOTES 201-01-142.

# Single Thru Hole IDC Contact

## 12-18 AWG: WTB

9177-600

### ASSEMBLY TOOLING

Part Number	Wire Insulation	A
06-9177-7021-01-000	Ø 3.50 - 4.25	4.25
06-9177-7021-01-000	Ø 3.50 - 4.25	4.25
06-9177-7021-01-000	Ø 3.50 - 4.25	4.25

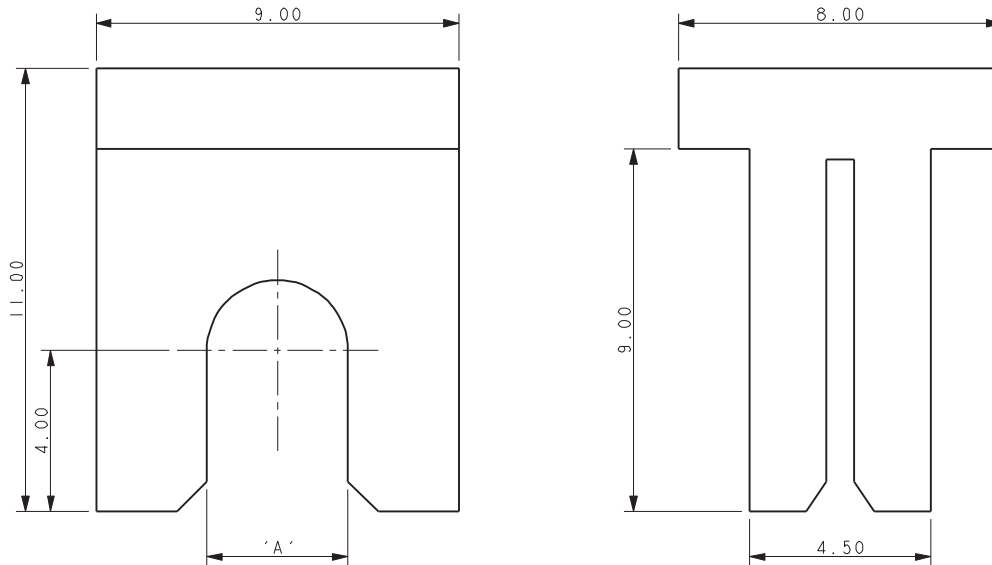

**NOTES:**

1. WIRE INSERTION TOOL 06-9177-7021-0X-000, FULL PART NUMBER REFER TO TABLE.
2. TOOL PART NUMBER DEPENDENT ON WIRE INSULATION DIAMETER NOT WIRE GAUGE OR CONTACT NUMBER.
3. ASSEMBLY DETAILS REFER TO APPLICATION NOTES 201-01-142
4. MATERIAL: TOOL STEEL.
5. APACE REQUIRED ON PCB FOR TOO. NO COMPONENTS IN THIS AREA.

### PCB CLEARANCE AREA FOR TOOL

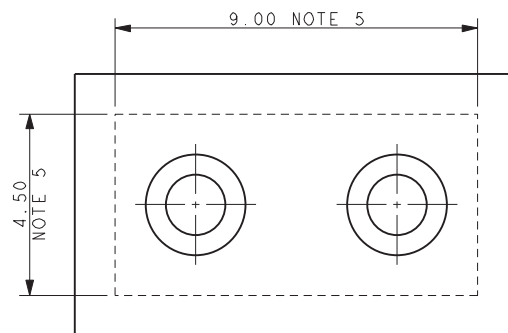

# Single Thru Hole IDC Contact

## 12-18 AWG: WTB

9177-600

### 60-9177-001-6XX-X00 1 WAY WIRE THROUGH CAP DETAILS

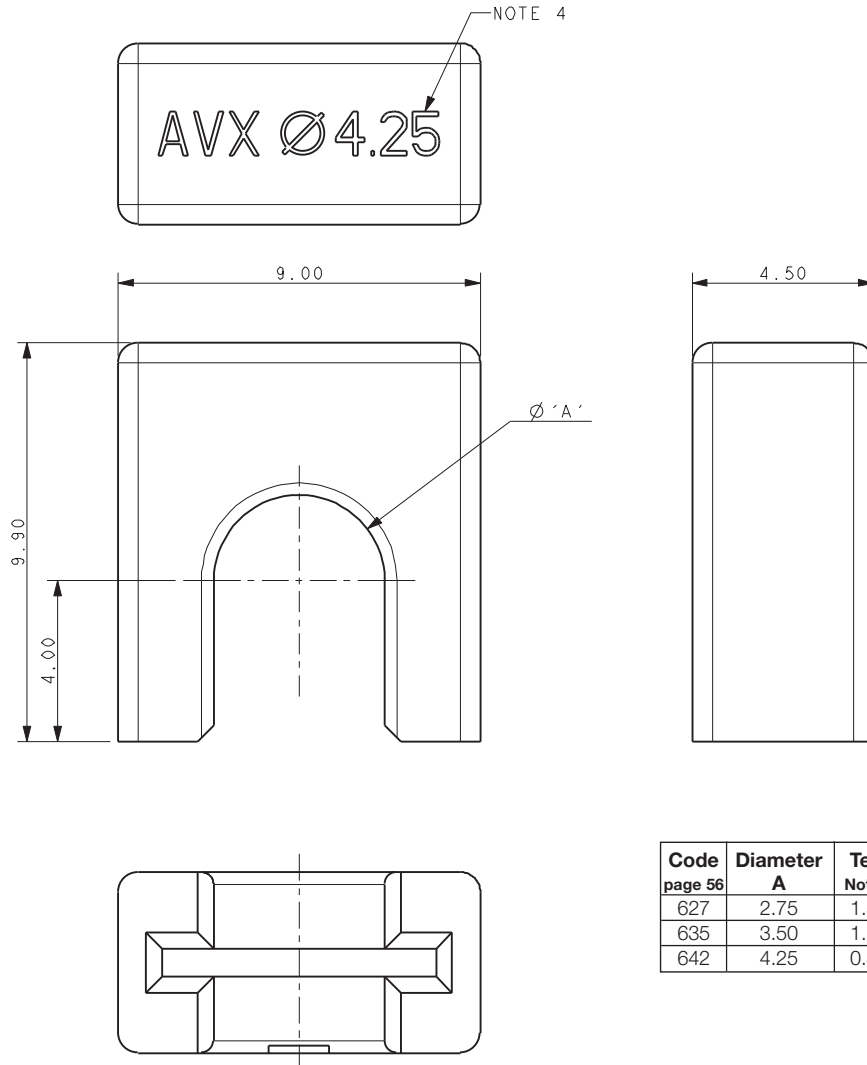

Code page 56	Diameter A	Text Note 4
627	2.75	1.50
635	3.50	1.10
642	4.25	0.82

**NOTES:**

1. CAP FOR IDC WIRE TO BOARD CONNECTION, 1 WAY WITH THROUGH WIRE.
2. WIRE THROUGH CAP FOR ASSEMBLY AT ANY POSITION ON A WIRE.
3. CAP MATERIAL: GLASS FILLED NYLON 46, UL94 V-0. COLOR SEE PAGE 56.
4. CAP DESIGNED TO ACCOMMODATE WIRE INSULATION.  
DIAMETERS 2.10MM TO 2.75MM, 2.75MM TO 3.50MM AND 3.50MM TO 4.25MM.
5. ALL DIMENSIONS  $\pm 0.20$  UNLESS STATED.
6. PACKED IN BAGS, QUANTITY 800 PIECES PER BAG.
7. PRODUCT SPECIFICATION REFER TO 201-01-141.
8. FOR ASSEMBLY DETAILS REFER TO APPLICATION NOTES 201-01-142.

# Single Thru Hole IDC Contact

## 12-18 AWG: WTB

9177-600

### 60-9177-001-6XX-X99 1 WAY WIRE STOP

#### CAP DETAILS

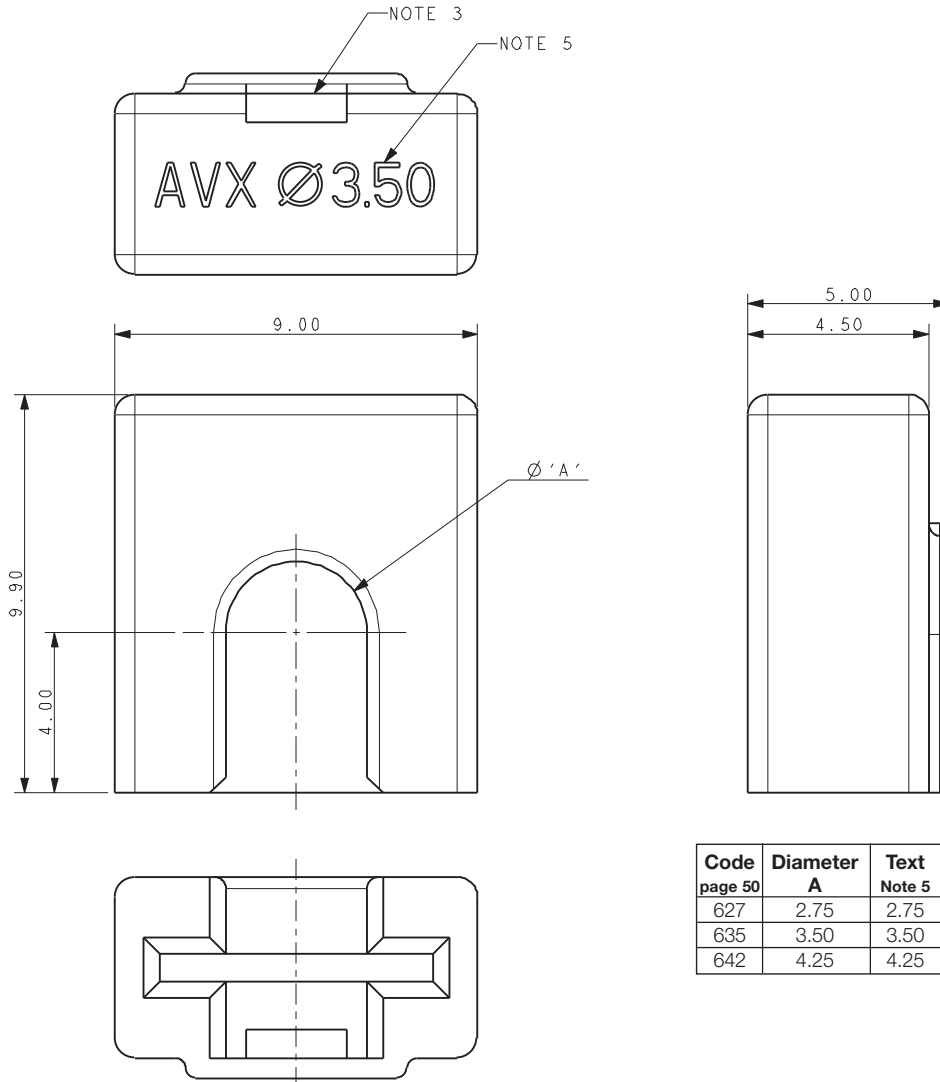

NOTES:

1. CAP FOR IDC WIRE TO BOARD CONNECTION, 1 WAY WITH WIRE STOP.
2. WIRE STOP FOR USE AT END OF WIRE.
3. SLOT TO CHECK WIRE POSITION BEFORE ASSEMBLY.
4. CAP MATERIAL: GLASS FILLED NYLON 46, UL94 V-0. COLOR SEE PAGE 56.
5. CAP DESIGNED TO ACCOMMODATE WIRE INSULATION.  
DIAMETERS 2.10MM TO 2.75MM, 2.75MM TO 3.50MM AND 3.50MM TO 4.25MM.
6. ALL DIMENSIONS  $\pm 0.20$  UNLESS STATED.
7. PACKED IN BAGS, QUANTITY 800 PIECES PER BAG.
8. PRODUCT SPECIFICATION REFER TO 201-01-141.
9. FOR ASSEMBLY DETAILS REFER TO APPLICATION NOTES 201-01-142.

# Poke-Home: Horizontal 18-26 AWG: WTB

00-9276



The new 9276 series connector provides a quick and reliable wire-to-board termination in a sleek 2.5mm pitch SMT package for a broad range of industrial and commercial markets. With almost every product on the market today having to deal with a small number of discrete wires to connect components to a board, the 9276 series connectors meets this challenge by simply stripping the wire and inserting them into the connector. This makes the connector very termination friendly within the factory as well as in the field by electrical installers. Developed for harsh industrial and Solid State Lighting (SSL) applications, the connector was designed with a high spring force Beryllium Copper upper spring contact to accept a wide range (18-26 AWG solid or stranded) of wire to meet multiple applications with a single connector. By incorporating a dual-contact design we were able to maximize current rating (6 Amps) and minimize PCB space. For example, the 4p connector has a footprint of 90 sq-mm while competing products are 160 sq-mm. The dual-contact design also provides two solder points for each wire eliminating the need for external anchor tabs. AVX provides a small insertion / extraction tool which will allow the wires to easily be replaced up to 5 times.

## APPLICATIONS

- Connecting discrete wire components directly to the PCB
- Bringing power and signals onto a PCB
- Daisy chaining PCB's together to create a continuous string of boards
- Application notes: refer to 201-01-127

## FEATURES AND BENEFITS

- Simple strip, insert and removal design
- SMT RoHS termination to the PCB with minimal footprint
- Accepts 18-26 AWG Solid and Stranded wires
- Expanded size offering to maximize application potential; 1, 2, 3, 4, 6 & 8 positions
- High spring force top contact provides a lance type retention to capture and retain the wire
- Available in standard white and optional black color

## ELECTRICAL

- Current Rating: 6 Amps / Contact
- Voltage Rating: 300 VAC

## ENVIRONMENTAL

- Operating Temperature: -40°C to +125°C

## MECHANICAL

- Insulator Material: Glass-Filled Nylon 46; UL94V0
- Contact Material: Beryllium Copper / Phosphor Bronze
- Plating: Tin over Nickel
- Replaceability: 5 Cycles

## HOW TO ORDER

<b>00</b>	<b>9276</b>	<b>00X</b>	<b>0</b>																					
Wire to Board Connector	Series	Number of Ways	Horizontal Mounting																					
		<table border="1"> <thead> <tr> <th>Code</th> <th>No of Ways</th> <th>Details</th> </tr> </thead> <tbody> <tr> <td>001</td> <td>1</td> <td>Page 63</td> </tr> <tr> <td>002</td> <td>2</td> <td>Page 64</td> </tr> <tr> <td>003</td> <td>3</td> <td>Page 65</td> </tr> <tr> <td>004</td> <td>4</td> <td>Page 66</td> </tr> <tr> <td>006</td> <td>6</td> <td>Page 67</td> </tr> <tr> <td>008</td> <td>8</td> <td>Page 68</td> </tr> </tbody> </table>	Code	No of Ways	Details	001	1	Page 63	002	2	Page 64	003	3	Page 65	004	4	Page 66	006	6	Page 67	008	8	Page 68	
Code	No of Ways	Details																						
001	1	Page 63																						
002	2	Page 64																						
003	3	Page 65																						
004	4	Page 66																						
006	6	Page 67																						
008	8	Page 68																						

<b>21</b>								
Wire Gauge Size								
<table border="1"> <thead> <tr> <th>Code</th> <th>Accepted Wire Gauge</th> <th>Max Conductor</th> <th>Max Insulation</th> </tr> </thead> <tbody> <tr> <td>21</td> <td>18 - 26 AWG Solid or Stranded</td> <td>1.20mm Diameter</td> <td>2.10mm Diameter</td> </tr> </tbody> </table>	Code	Accepted Wire Gauge	Max Conductor	Max Insulation	21	18 - 26 AWG Solid or Stranded	1.20mm Diameter	2.10mm Diameter
Code	Accepted Wire Gauge	Max Conductor	Max Insulation					
21	18 - 26 AWG Solid or Stranded	1.20mm Diameter	2.10mm Diameter					

<b>X</b>	<b>06</b>
Insulator Color	Plating Option
9 = UL White 8 = UL Black	06 = Tin all over



Thin Blade Removal Tool  
Part Number 06-9276-7001-01-000

Certification: UL File #E90723

# Poke-Home: Horizontal 18-26 AWG: WTB

00-9276

## WIRE ASSEMBLY

FOR FURTHER DETAILS REFER TO APPLICATION NOTES 201-01-127

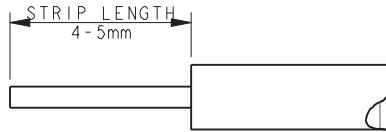

TRIM INSULATION.  
DO NOT CRUSH CENTER OF WIRE.  
STRANDED WIRES TWISTED TOGETHER BEFORE INSERTION.  
CHECK ALL STANDS OF WIRE ARE CORRECTLY ALIGNED  
AFTER THE INSULATION IS REMOVED.

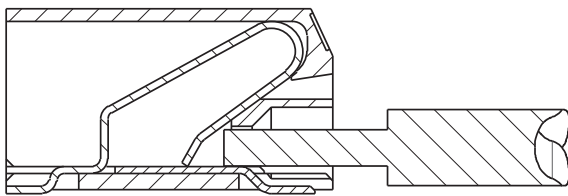

PUSH WIRE INTO HOLE IN FRONT OF CONNECTOR  
DO NOT BEND CONNECTOR

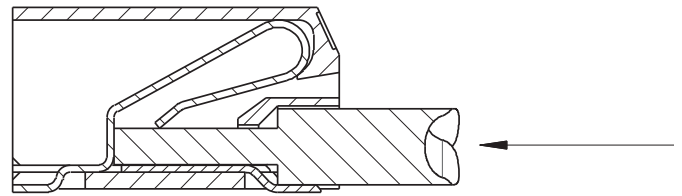

CONTINUED TO PUSH WIRE UNTIL STOP IS REACHED.

## WIRE EXTRACTION

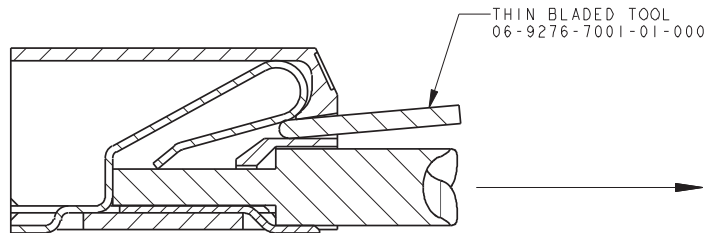

PUSH BLADE (NOT SHARP) INTO SLOT ABOVE WIRE.  
WHEN WIRE IS FREE, PULL TO EXTRACT.

# Poke-Home: Horizontal 18-26 AWG: WTB

00-9276

## 1 WAY WIRE TO BOARD CONNECTOR

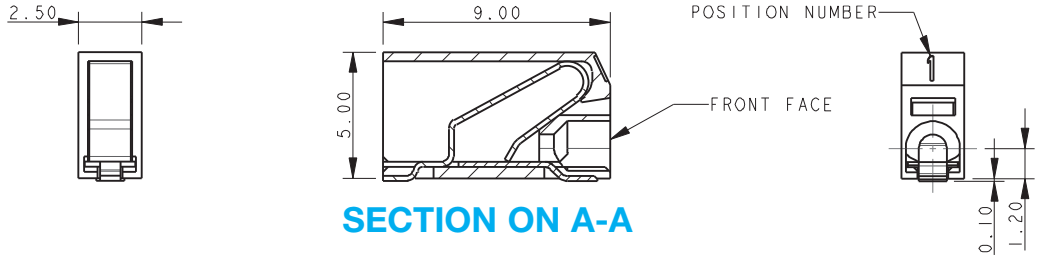

**SECTION ON A-A**

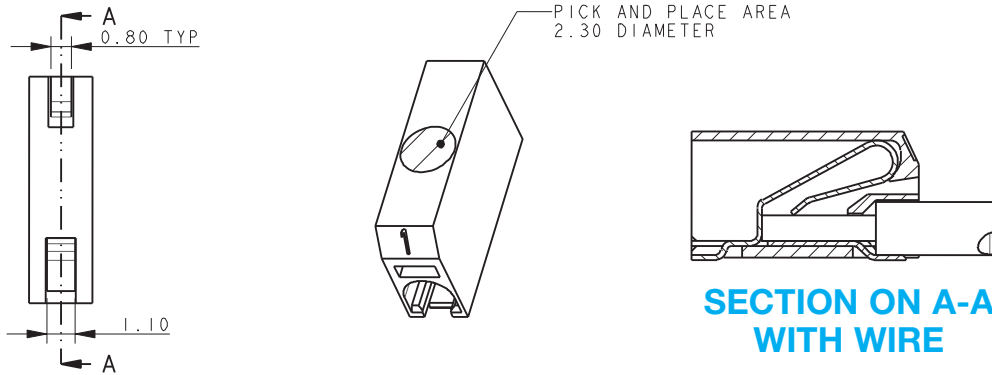

**NOTES:**

1. 9276 ONE WAY CONNECTOR, REFER TO ELCO SPECIFICATION 201-01-125 AND APPLICATION NOTES 201-01-127 FOR FURTHER DETAILS
2. INSULATOR MATERIAL: NYLON 46, GLASS FILLED, UL94 V-0, COLOR REFER TO PAGE 61.
3. CONTACT MATERIAL: COPPER ALLOY, 0.20MM THICK, TIN PLATED.
4. OUTLINE OF CONNECTOR.
5. WIRE ASSEMBLY / EXTRACTION, REFER TO PAGE 62.
6. FRONT FACE OF CONNECTOR CAN BE IN LINE WITH EDGE OF PCB.
7. PACKING TAPE AND REEL, QUANTITY 1000 PER REEL.

## PACKING DETAILS

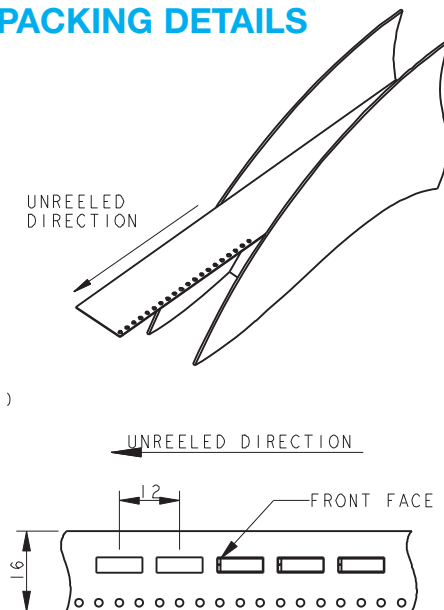

## 1 WAY PCB BOARD LAYOUT

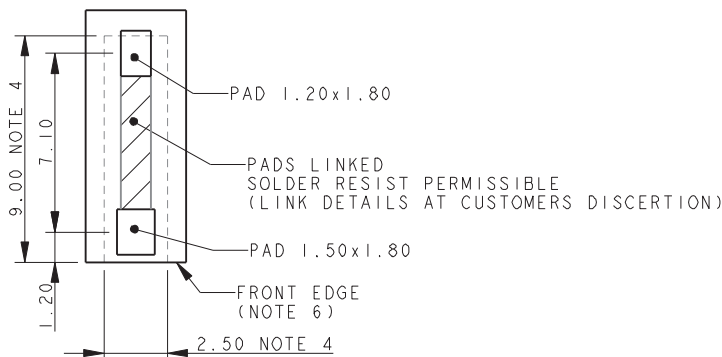



# Poke-Home: Horizontal 18-26 AWG: WTB

00-9276

## 2 WAY WIRE TO BOARD CONNECTOR

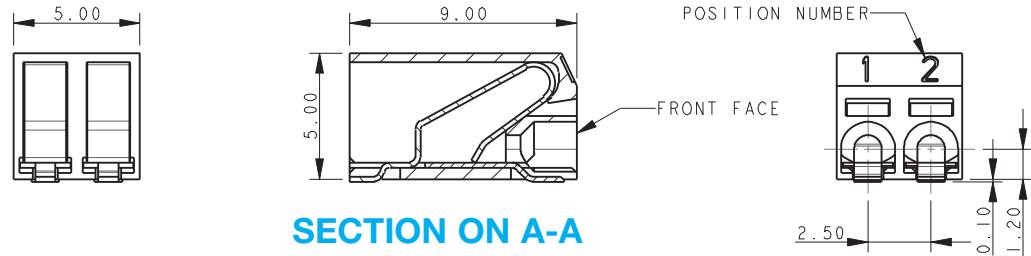

**SECTION ON A-A**

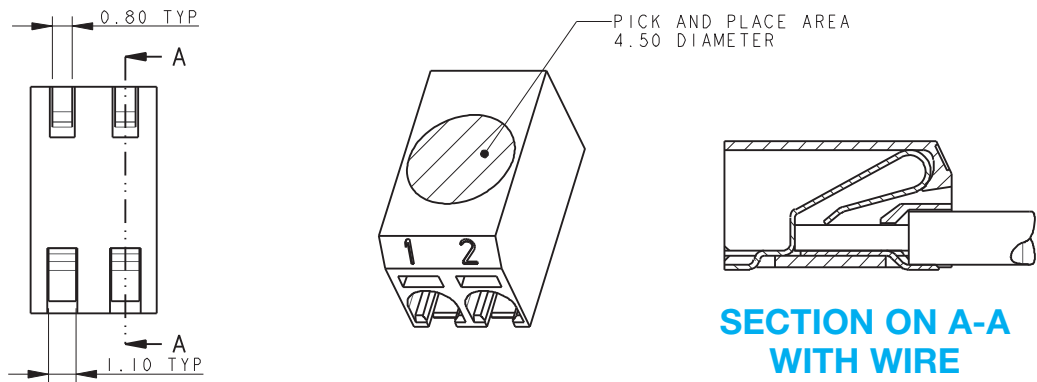

**NOTES:**

1. 9276 TWO WAY CONNECTOR, REFER TO ELCO SPECIFICATION 201-01-125 AND APPLICATION NOTES 201-01-127 FOR FURTHER DETAILS
2. INSULATOR MATERIAL: NYLON 46, GLASS FILLED, UL94 V-0, COLOR REFER TO PAGE 61.
3. CONTACT MATERIAL: COPPER ALLOY, 0.20MM THICK, TIN PLATED.
4. OUTLINE OF CONNECTOR.
5. WIRE ASSEMBLY / EXTRACTION, REFER TO PAGE 62.
6. FRONT FACE OF CONNECTOR CAN BE IN LINE WITH EDGE OF PCB.
7. PACKING TAPE AND REEL, QUANTITY 1000 PER REEL.

## 2 WAY PCB BOARD LAYOUT

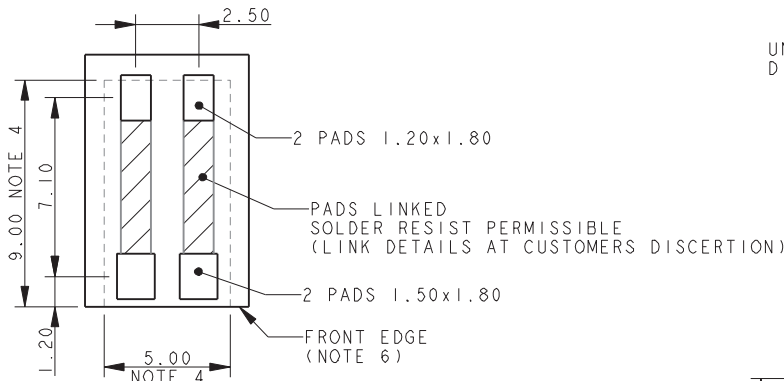

## PACKING DETAILS

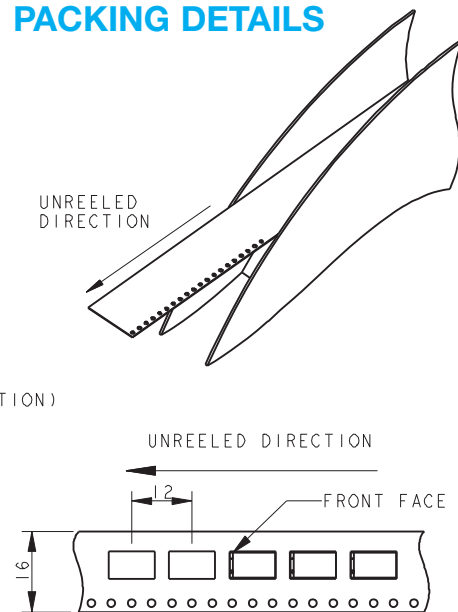

# Poke-Home: Horizontal 18-26 AWG: WTB

00-9276

## 3 WAY WIRE TO BOARD CONNECTOR

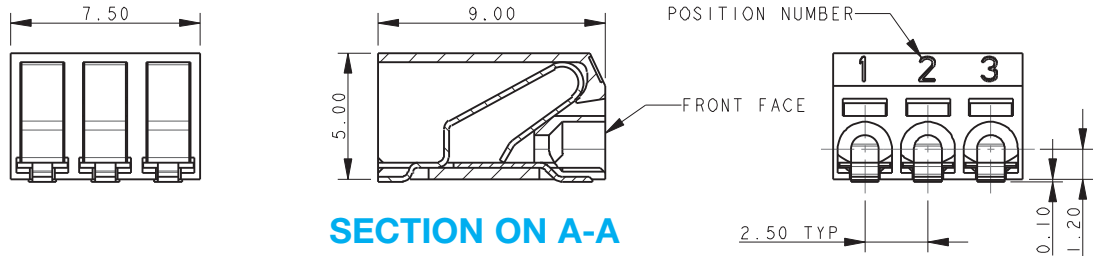

SECTION ON A-A

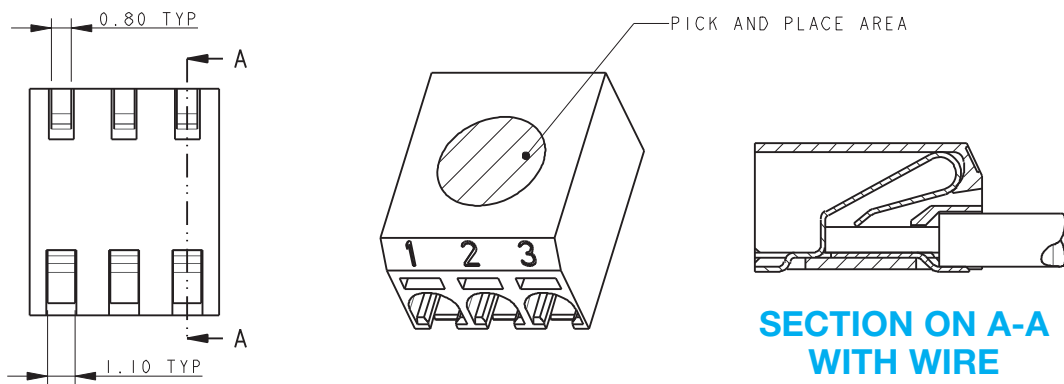

NOTES:

1. 9276 THREE WAY CONNECTOR, REFER TO ELCO SPECIFICATION 201-01-125 AND APPLICATION NOTES 201-01-127 FOR FURTHER DETAILS
2. INSULATOR MATERIAL: NYLON 46, GLASS FILLED, UL94 V-0, COLOR REFER TO PAGE 61.
3. CONTACT MATERIAL: COPPER ALLOY, 0.20MM THICK, TIN PLATED.
4. OUTLINE OF CONNECTOR.
5. WIRE ASSEMBLY / EXTRACTION, REFER TO PAGE 62.
6. FRONT FACE OF CONNECTOR CAN BE IN LINE WITH EDGE OF PCB.
7. PACKING TAPE AND REEL, QUANTITY 1000 PER REEL.

## 3 WAY PCB BOARD LAYOUT

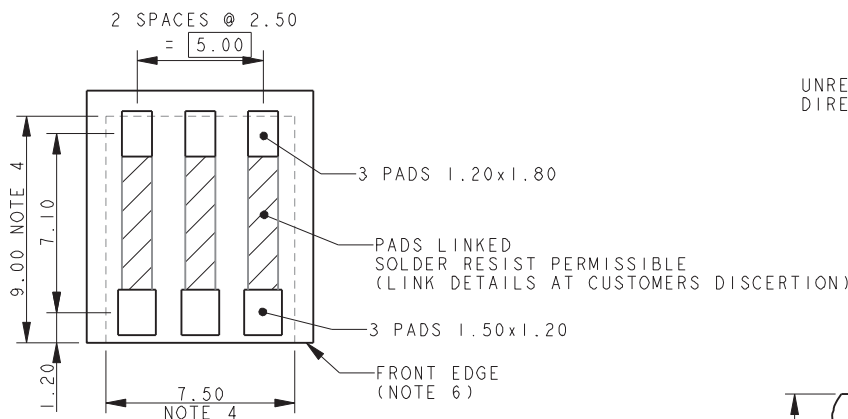

## PACKING DETAILS

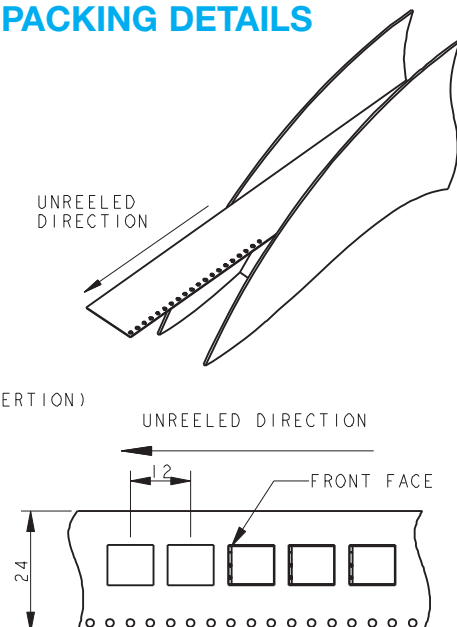

# Poke-Home: Horizontal 18-26 AWG: WTB

00-9276

## 4 WAY WIRE TO BOARD CONNECTOR

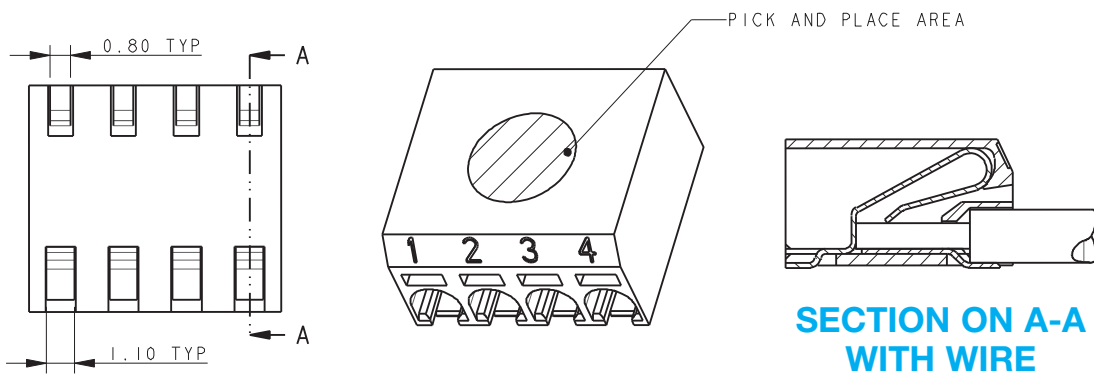
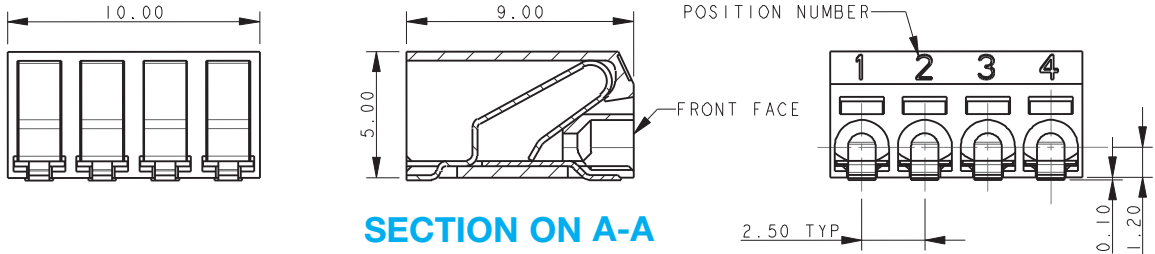

**NOTES:**

1. 9276 FOUR WAY CONNECTOR, REFER TO ELCO SPECIFICATION 201-01-125 AND APPLICATION NOTES 201-01-127 FOR FURTHER DETAILS
2. INSULATOR MATERIAL: NYLON 46, GLASS FILLED, UL94 V-0, COLOR REFER TO PAGE 61.
3. CONTACT MATERIAL: COPPER ALLOY, 0.20MM THICK, TIN PLATED.
4. OUTLINE OF CONNECTOR.
5. WIRE ASSEMBLY / EXTRACTION, REFER TO PAGE 62.
6. FRONT FACE OF CONNECTOR CAN BE IN LINE WITH EDGE OF PCB.
7. PACKING TAPE AND REEL, QUANTITY 1000 PER REEL.

## 4 WAY PCB BOARD LAYOUT

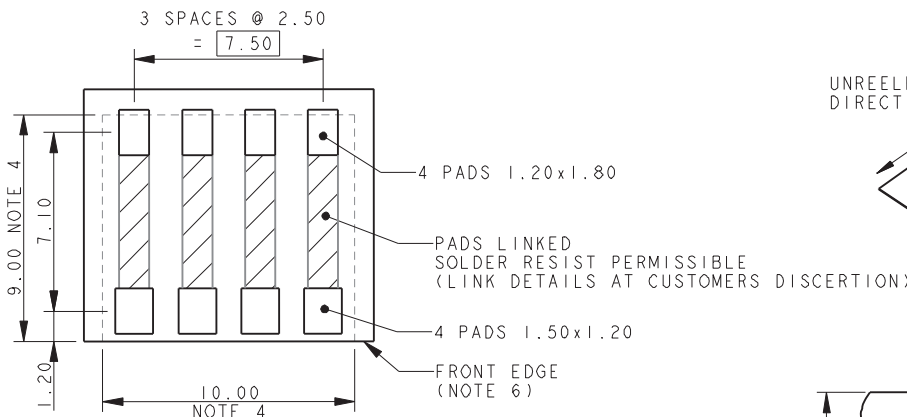

## PACKING DETAILS

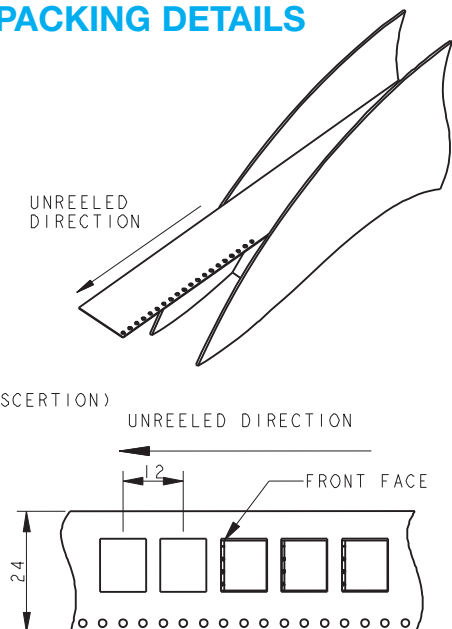

# Poke-Home: Horizontal 18-26 AWG: WTB

00-9276

## 6 WAY WIRE TO BOARD CONNECTOR

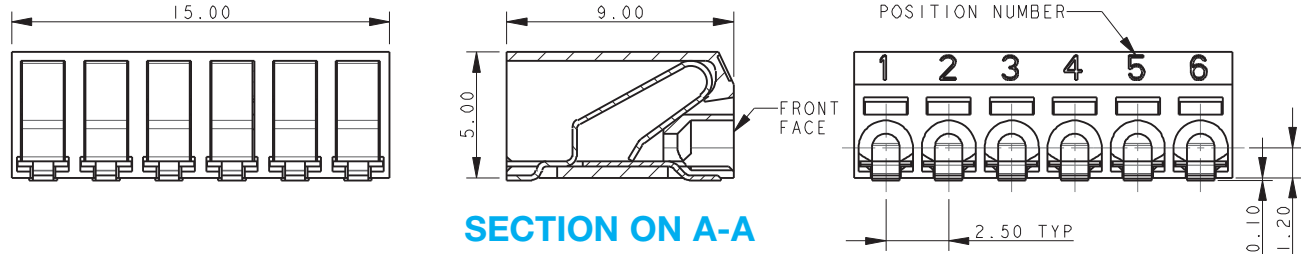

**SECTION ON A-A**

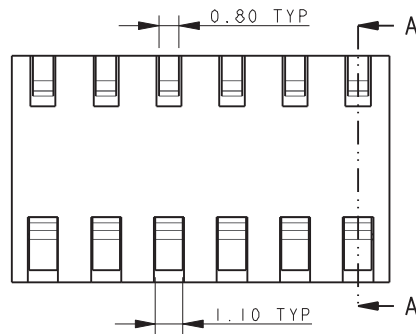

**SECTION ON A-A  
WITH WIRE**

**NOTES:**

1. 9276 SIX WAY CONNECTOR, REFER TO ELCO SPECIFICATION 201-01-125 AND APPLICATION NOTES 201-01-127 FOR FURTHER DETAILS
2. INSULATOR MATERIAL: NYLON 46, GLASS FILLED, UL94 V-0, COLOR REFER TO PAGE 61.
3. CONTACT MATERIAL: COPPER ALLOY, 0.20MM THICK, TIN PLATED.
4. OUTLINE OF CONNECTOR.
5. WIRE ASSEMBLY / EXTRACTION, REFER TO PAGE 62.
6. FRONT FACE OF CONNECTOR CAN BE IN LINE WITH EDGE OF PCB.
7. PACKING TAPE AND REEL, QUANTITY 1000 PER REEL.

## 6 WAY PCB BOARD LAYOUT

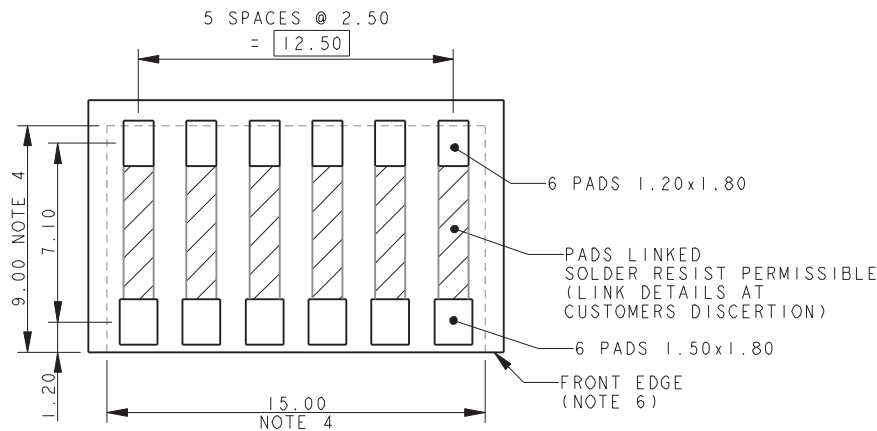

## PACKING DETAILS

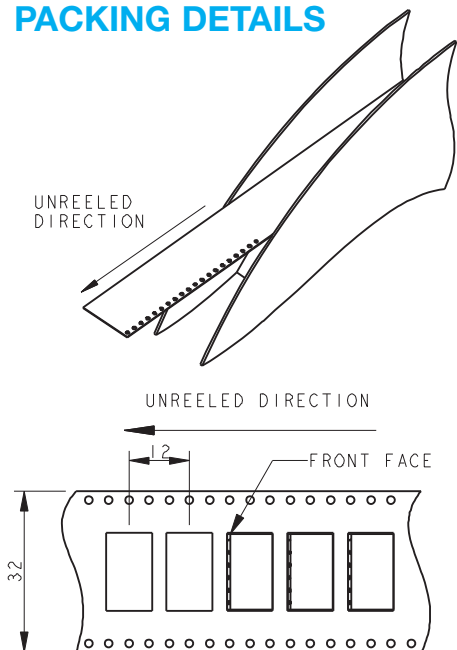

# Poke-Home: Horizontal 18-26 AWG: WTB

00-9276

## 8 WAY WIRE TO BOARD CONNECTOR

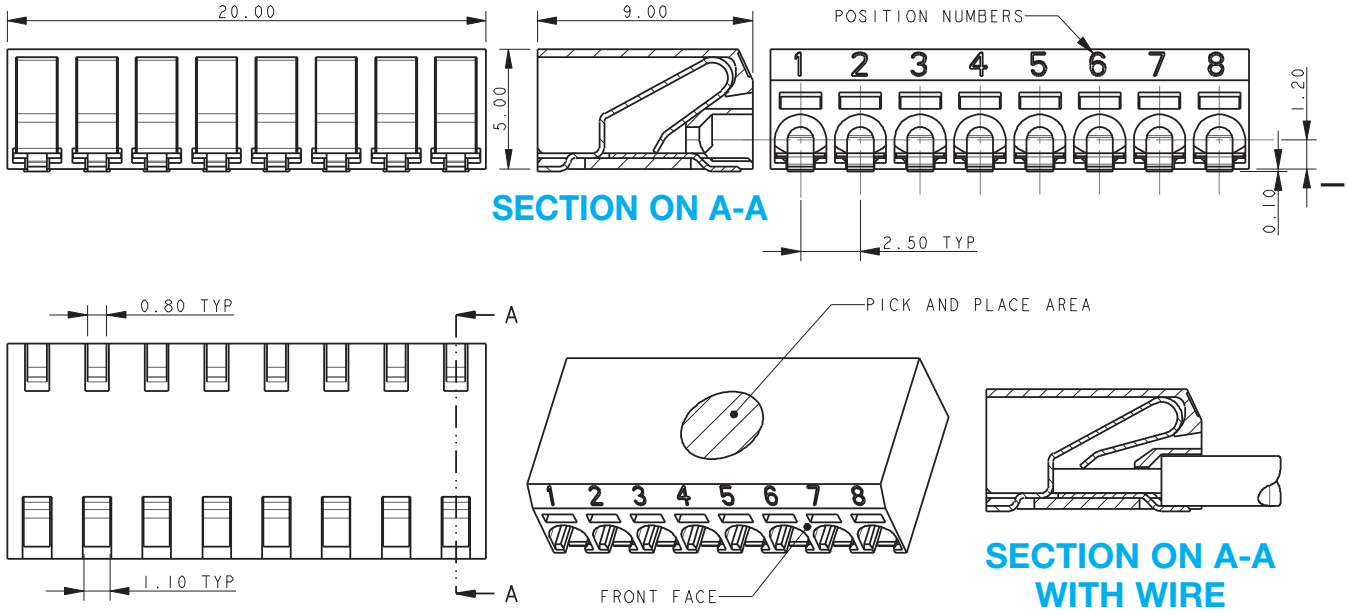

**NOTES:**

1. 9276 EIGHT WAY CONNECTOR, REFER TO ELCO SPECIFICATION 201-01-125 AND APPLICATION NOTES 201-01-127 FOR FURTHER DETAILS
2. INSULATOR MATERIAL: NYLON 46, GLASS FILLED, UL94 V-0, COLOR REFER TO PAGE 61.
3. CONTACT MATERIAL: COPPER ALLOY, 0.20MM THICK, TIN PLATED.
4. OUTLINE OF CONNECTOR.
5. WIRE ASSEMBLY / EXTRACTION, REFER TO PAGE 62.
6. FRONT FACE OF CONNECTOR CAN BE IN LINE WITH EDGE OF PCB.
7. PACKING TAPE AND REEL, QUANTITY 1000 PER REEL.

## PACKING DETAILS

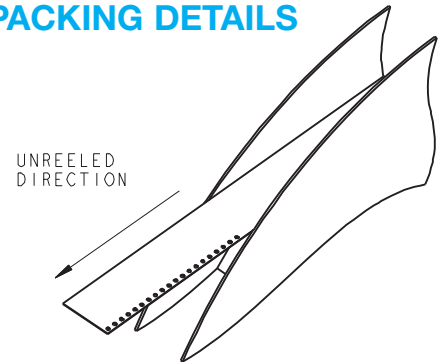

## 8 WAY PCB BOARD LAYOUT

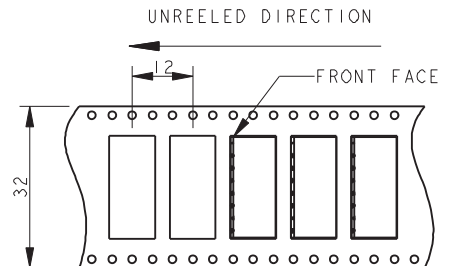
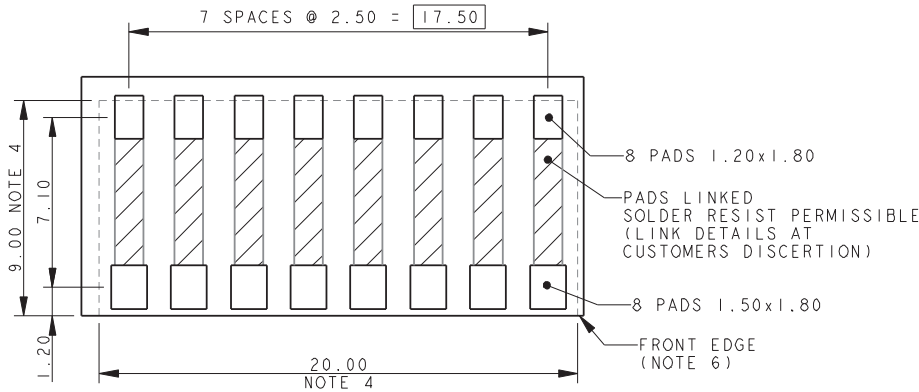

# Poke-Home: Single Horizontal Contact

## 12-28 AWG: WTB



70-9296



The Industrial and Solid State Lighting markets continue to look for new products which will reduce size and cost without jeopardizing performance. The new dual-beam boxed contact system from AVX surface mounts to a PCB and provides a simple and reliable wire termination without soldering of the wire. The unique contact design integrates several key features within the stamping to facilitate SMT pickup, wire guidance, high force retention and easy wire removal. Combined, these features provide all of the benefits of a full function connector, without the added cost of the insulator and labor.

This family of 4mm, 3mm, 2mm and 1.7mm closed box contacts accept either solid or stranded wires ranging from 12AWG to 28AWG with current ratings up to 20Amps. Once the contacts are soldered onto the PCB, wires need to be stripped to length (twisted if stranded) and inserted into the open end of the box contact. As the wires are pushed in, upper and lower tines guide the wire down the center of the contact deflecting the right and left contact tines until the wire reaches the wire stop. Wires can be removed by twisting the wire out and or using a small blade removal tool to help release some of the contact force.

### APPLICATIONS

- Industrial/Ruggedized Wire-to-Board applications
- Replace hard soldering of wire to a PCB
- Reference Product Specification 201-01-143
- Reference Application Notes 201-01-150

### FEATURES AND BENEFITS

- Dual Beam box contact provides maximum mechanical stability and wire retention
- Tape and reel packaged for automated SMT placement
- Staged current rating based on AWG, maximum is 20A (12AWG)
- Increased functionality with the single contact placement ability; multiple contacts and/or specific individual locations

### ELECTRICAL

- Voltage Rating: 300V  
Based on placement distance
- Current Rating: See Matrix Below

### ENVIRONMENTAL

- Operating Temperature:  
-40°C to +125°C

### MECHANICAL

- Contact Material: Phosphor Bronze
- Contact Plating: Tin over Nickel
- Durability 5 Cycles

### HOW TO ORDER

**70**      **9296**      **001**  
 |            |            |  
 Prefix    Series    Number of Ways  
 70 = Contact      001 = 1

**00X**  
 |  
 Contact Size

Code	Contact Size	Wire Gauge	Max Insulation
017	1.7mm Contact	22-26 AWG Solid or Stranded	1.3mm Ø (See page 70)
002	2mm Contact	22-28 AWG Solid or Stranded	1.5mm Ø (See page 70)
003	3mm Contact	18-26 AWG Solid or Stranded	2.5mm Ø
004	4mm Contact	12-20 AWG Solid or Stranded	3.4mm Ø

**006**  
 |  
 Plating Option  
 Tin all over



### CURRENT RATING

Size	Part Number	12AWG	14AWG	16AWG	18AWG	20AWG	22AWG	24AWG	26AWG	28AWG
4mm	709296001004006	20A	16A	14A	12A	10A				
3mm	709296001003006				12A	10A	8A	7A	5A	
2mm	709296001002006						8A	7A	5A	4A
1.7mm	709296001017006						8A	7A	5A	

Certification: UL File #E90723



# Poke-Home: Single Horizontal Contact

## 12-28 AWG: WTB

70-9296

### 70-9296-001-017-006 1.7MM POKE HOME CONTACT

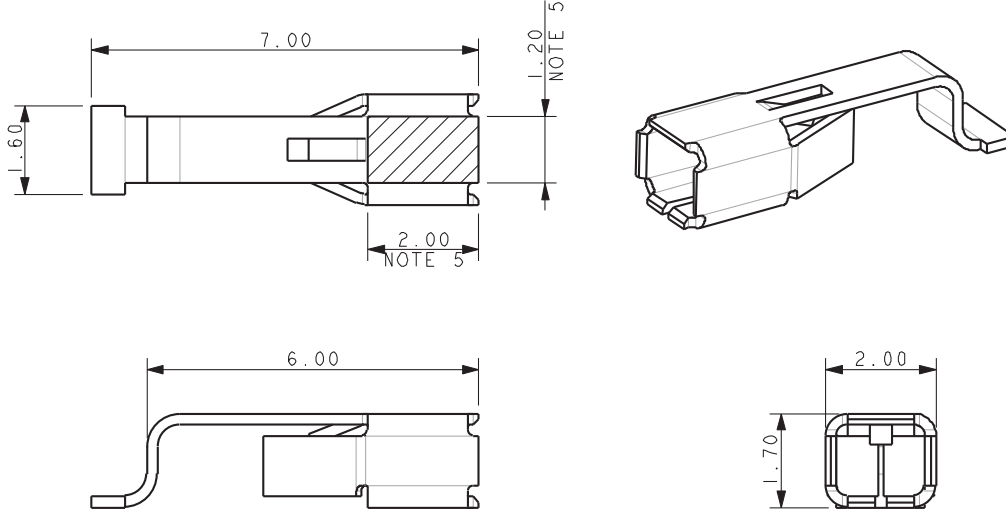

**NOTES:**

1. FOR FURTHER INFORMATION REFER TO ELCO SPECIFICATION 201-01-143 AND APPLICATION NOTES 201-01-150.
2. MATERIAL: TIN PLATED PHOSPHOR BRONZE.
3. PACKING IN TAPE AND REEL, 4000 PIECES PER REEL.
4. FOR WIRE TRIM DETAILS REFER TO PAGE 74.
5. AREA AVAILABLE FOR PICK AND PLACE.

### SUGGESTED PCB LAYOUT

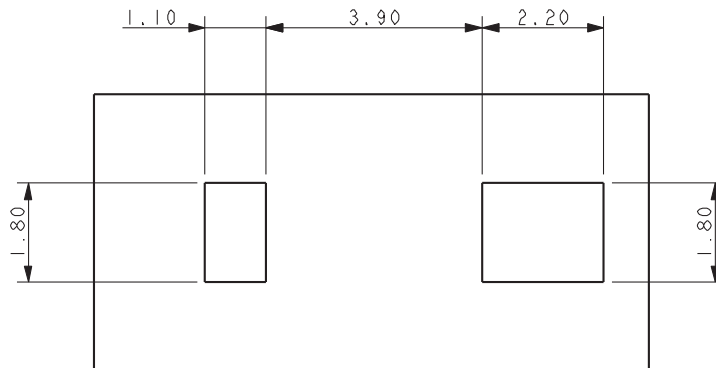

### PACKING DETAILS

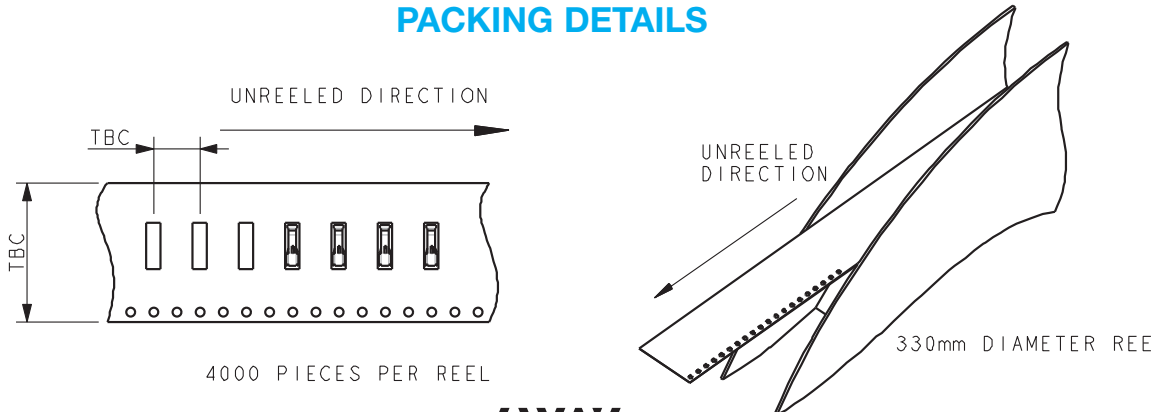

# Poke-Home: Single Horizontal Contact

## 12-28 AWG: WTB

70-9296

### 70-9296-001-002-006 2MM POKE HOME CONTACT

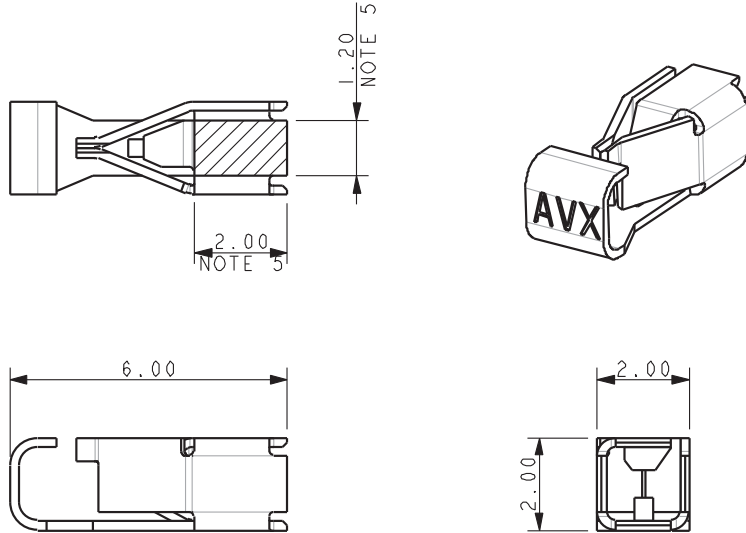

**NOTES:**

1. FOR FURTHER INFORMATION REFER TO ELCO SPECIFICATION 201-01-143 AND APPLICATION NOTES 201-01-150.
2. MATERIAL: TIN PLATED PHOSPHOR BRONZE.
3. PACKING IN TAPE AND REEL, 3500 PIECES PER REEL.
4. FOR WIRE TRIM DETAILS REFER TO PAGE 74.
5. AREA AVAILABLE FOR PICK AND PLACE.

### SUGGESTED PCB LAYOUT

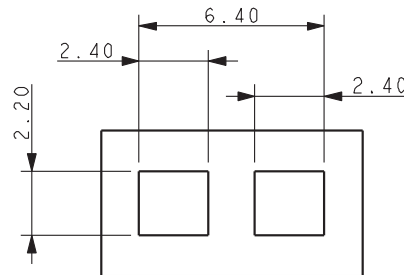

### PACKING DETAILS

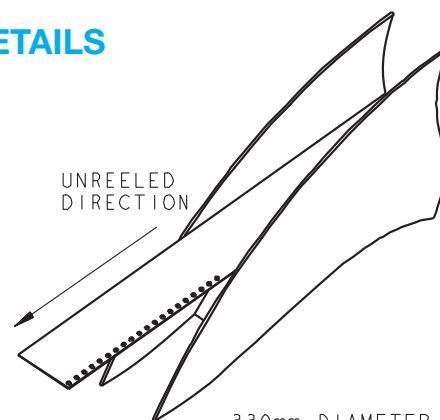
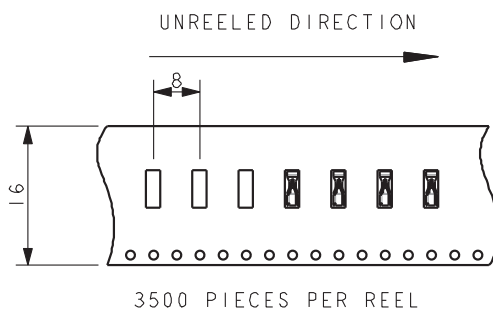

330mm DIAMETER REEL



# Poke-Home: Single Horizontal Contact

## 12-28 AWG: WTB

70-9296

### 70-9296-001-003-006 3MM POKE HOME CONTACT

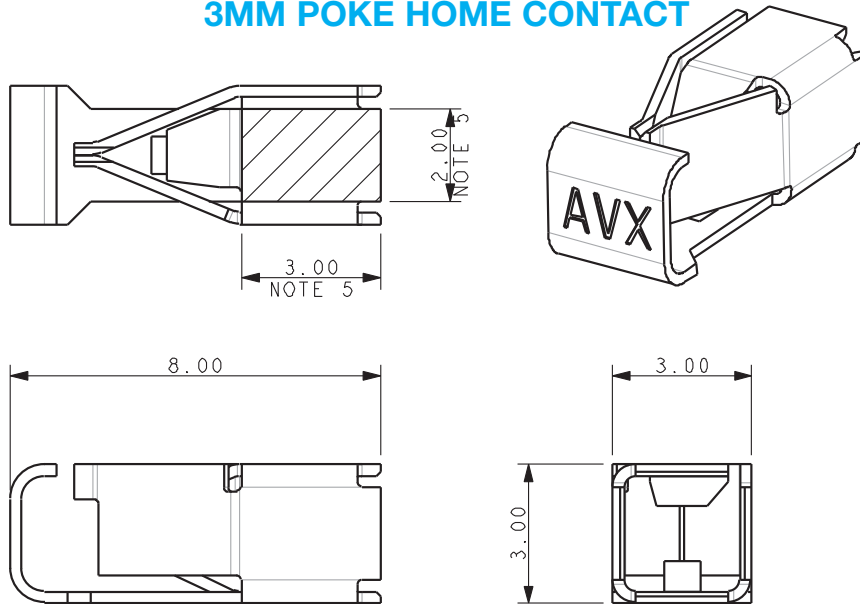

**NOTES:**

1. FOR FURTHER INFORMATION REFER TO ELCO SPECIFICATION 201-01-143 AND APPLICATION NOTES 201-01-150.
2. MATERIAL: TIN PLATED PHOSPHOR BRONZE.
3. PACKING IN TAPE AND REEL, 2500 PIECES PER REEL.
4. FOR WIRE TRIM DETAILS REFER TO PAGE 74.
5. AREA AVAILABLE FOR PICK AND PLACE.

### SUGGESTED PCB LAYOUT

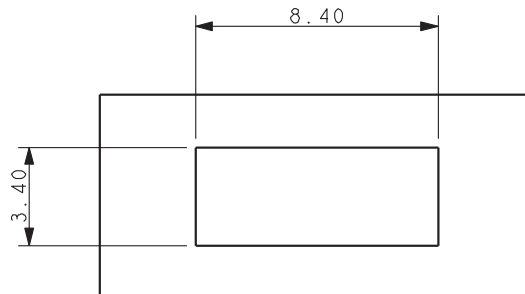

### PACKING DETAILS

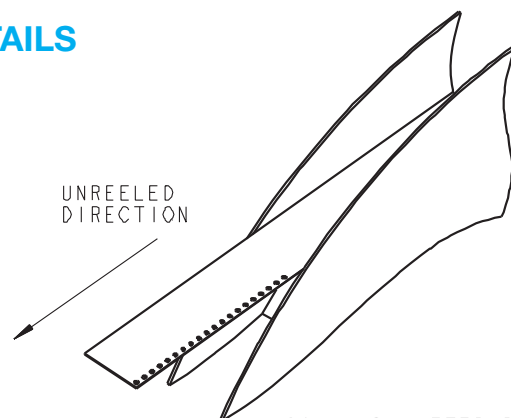
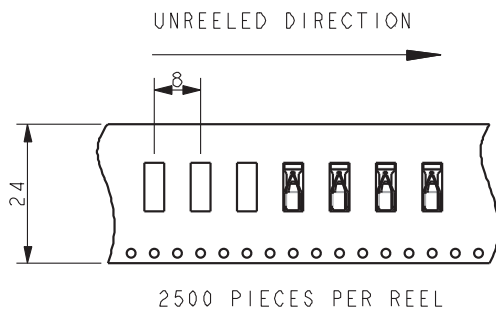

# Poke-Home: Single Horizontal Contact

## 12-28 AWG: WTB

70-9296

### 70-9296-001-004-006 4MM POKE HOME CONTACT

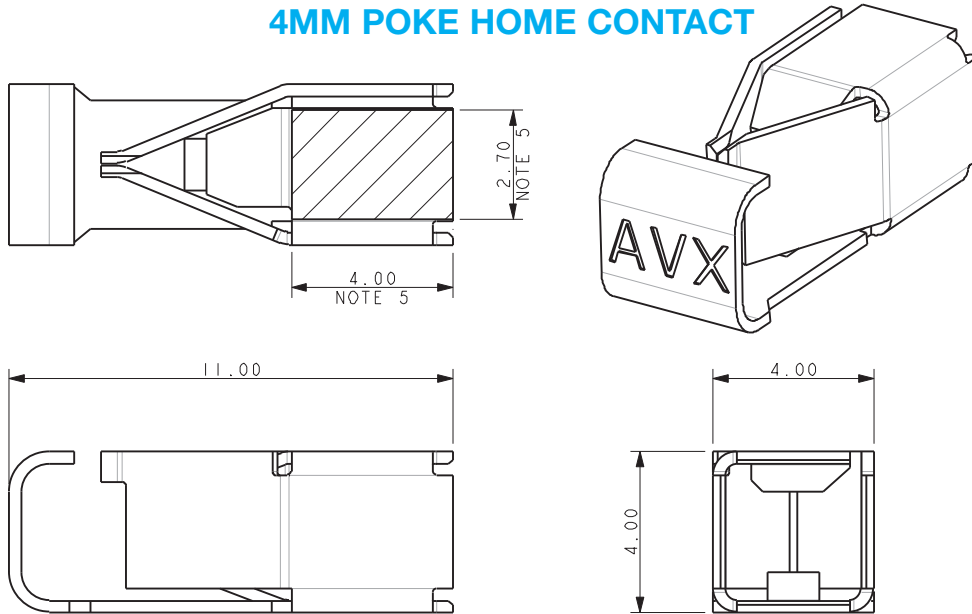

**NOTES:**

1. FOR FURTHER INFORMATION REFER TO ELCO SPECIFICATION 201-01-143 AND APPLICATION NOTES 201-01-150.
2. MATERIAL: TIN PLATED PHOSPHOR BRONZE.
3. PACKING IN TAPE AND REEL, 2000 PIECES PER REEL.
4. FOR WIRE TRIM DETAILS REFER TO PAGE 74.
5. AREA AVAILABLE FOR PICK AND PLACE.

### SUGGESTED PCB LAYOUT

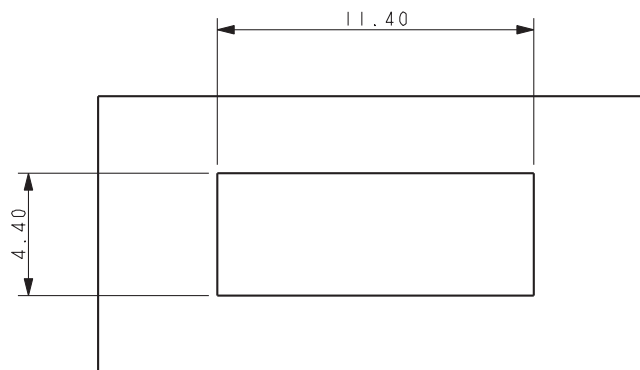

### PACKING DETAILS

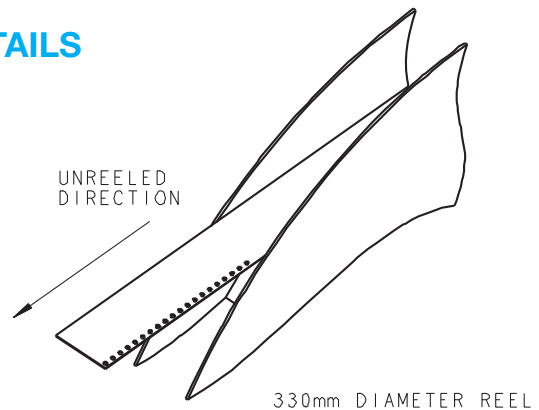
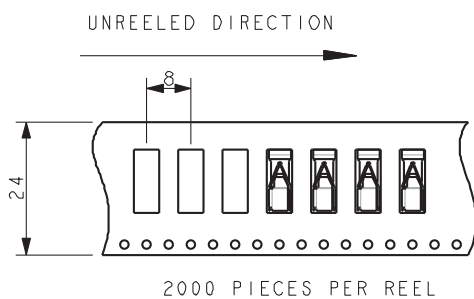

# Poke-Home: Single Horizontal Contact

## 12-28 AWG: WTB

70-9296

### CONNECTOR ASSEMBLY

FOR FULL DETAILS REFER TO APPLICATION NOTES 201-01-150

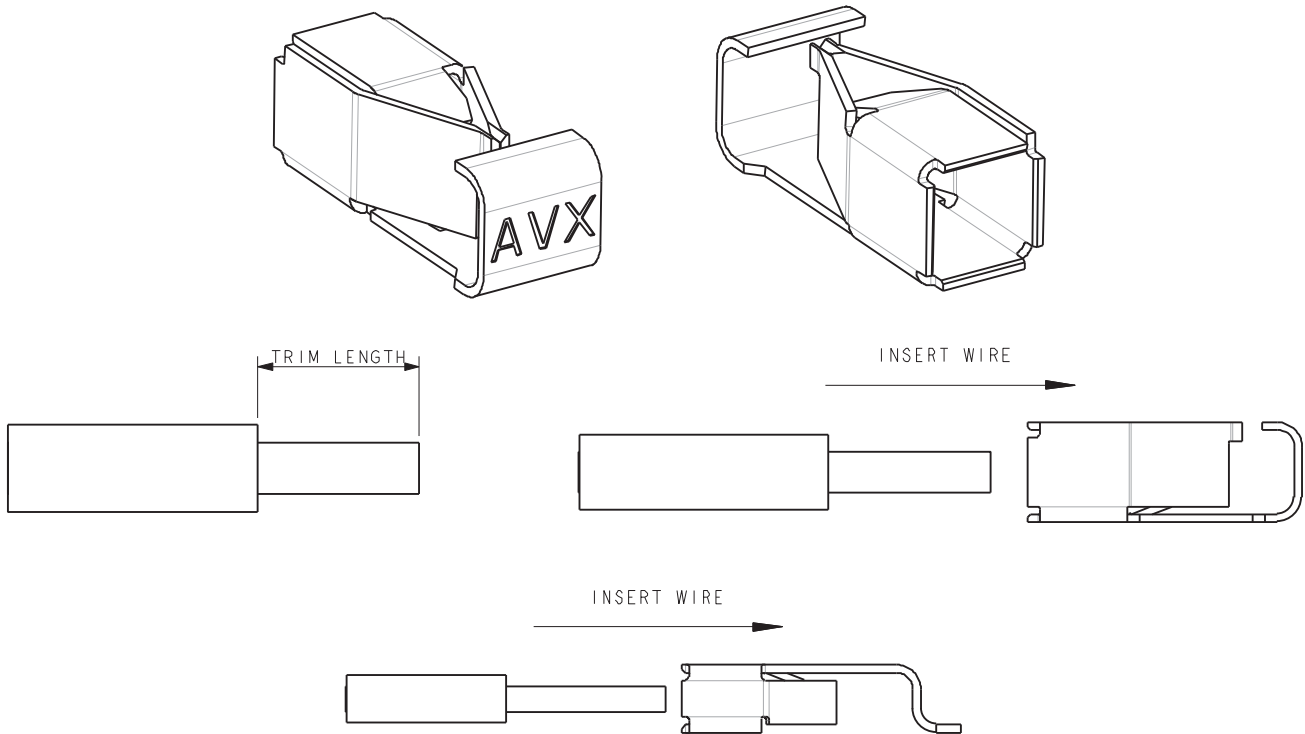

CONTACT	WIRE SIZE	INSULATOR DIAMETER	TRIM LENGTH
70-9206-001-004-006	12AWG and 14AWG	Max 3.4mm	6.5 ± 0.5mm
70-9296-001-004-006	16AWG, 18AWG and 20AWG	Max 2.5mm	5.5 ± 0.5mm
70-9296-001-003-006	18AWG to 26AWG	Max 2.5mm	3.5 ± 0.5mm
70-9296-001-002-006	22AWG to 28AWG	Max 1.5mm	3.5 ± 0.5mm
70-9296-001-002-006	22AWG to 28AWG	1.5mm to 2.0mm	5.5 ± 0.5mm*
70-9296-001-017-006	22AWG to 26AWG	Max 1.3mm	4.0 ± 0.5mm
70-9296-001-017-006	22AWG to 26AWG	1.3mm to 1.7mm	6.0 ± 0.5mm*

\* Wire insulation butts on end of contact

### CONTACT OPENING TOOL

06-9296-7001-01-000

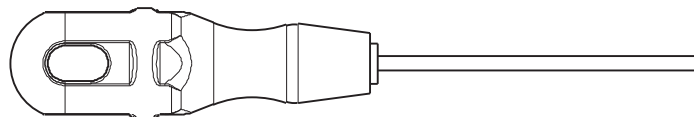

TOOL TO OPEN THE CONTACT TO INSERT/WITHDRAW WIRE.  
REFER TO APPLICATION NOTES 201-01-150.

# Poke-Home: Vertical Top Entry 18-26 AWG: WTB

00-9296



AVX continues to develop innovative connectors for the industrial electronics market that provide significant benefits over existing, outdated connector solutions. Listening to the design engineering community, there are ongoing applications where they cannot find an off-the-shelf solution that will satisfy a high percentage of the projects configuration, performance and cost goals.

The newest addition to AVX's broadening line of Wire-to-Board (WTB) connectors offers a cost effective, single Poke-Home connector solution that will meet the cost and performance targets in demanding, yet user friendly applications. At the heart of the connector is the industry proven dual tine, 3mm high spring force box contact that has been on the market as a stand-alone horizontal contact only solution.

The new SMT vertical top entry connector allows for 18AWG to 26AWG wires to be simply stripped and inserted into the connector body at 180 degree orientation to the top side of the PCB. This single connector will replace existing 2-Piece WTB solutions where a header is soldered onto the PCB and a secondary crimp-to-wire receptacle assembly is plugged in. Available in 1-6 positions, each connector will accept the entire wire gauge range for either solid or stranded wires at varying current ratings supported by each wire size. Once inserted, wires can easily be removed or replaced by twisting/unscrewing or by using a small blade extraction tool.

## APPLICATIONS

- Industrial/Ruggedized Wire-to-Board applications
- Replace hard soldering of wire to a PCB
- Replace costly 2-Piece header and receptacle products
- Reference Product Specification 201-01-151
- Reference Application Notes 201-01-152

## FEATURES AND BENEFITS

- Dual Beam box contact provides maximum mechanical stability and wire retention
- Tape and reel packaged for automated SMT placement
- Will accept either solid or stranded wire, 18-26AWG, plated or un-plated wires
- Simple strip and insert for wire loading, with easy twist and pull for wire removal

## ELECTRICAL

- Voltage Rating: 200 VAC
- Current Rating: See matrix below

## ENVIRONMENTAL

- Operating Temperature: -40°C to +125°C

## MECHANICAL

- Contact Material: Copper Alloy
- Contact Plating: Tin over Nickel
- Durability: 5 Cycles

## HOW TO ORDER

<b>00</b>	<b>9296</b>	<b>00X</b>																					
Prefix	Series	Number of Ways																					
		<table border="1"> <thead> <tr> <th>Code</th> <th>No of Ways</th> <th>Details</th> </tr> </thead> <tbody> <tr> <td>001</td> <td>1</td> <td>Page 76</td> </tr> <tr> <td>002</td> <td>2</td> <td>Page 77</td> </tr> <tr> <td>003</td> <td>3</td> <td>Page 78</td> </tr> <tr> <td>004</td> <td>4</td> <td>Page 79</td> </tr> <tr> <td>005</td> <td>5</td> <td>Page 80</td> </tr> <tr> <td>006</td> <td>6</td> <td>Page 81</td> </tr> </tbody> </table>	Code	No of Ways	Details	001	1	Page 76	002	2	Page 77	003	3	Page 78	004	4	Page 79	005	5	Page 80	006	6	Page 81
Code	No of Ways	Details																					
001	1	Page 76																					
002	2	Page 77																					
003	3	Page 78																					
004	4	Page 79																					
005	5	Page 80																					
006	6	Page 81																					

<b>553</b>						
Wire Gauge Size						
<table border="1"> <thead> <tr> <th>Code</th> <th>Accepted Wire Gauge</th> <th>Max Insulation</th> </tr> </thead> <tbody> <tr> <td>553</td> <td>18 – 26 AWG Solid or Stranded</td> <td>2.2mm</td> </tr> </tbody> </table>	Code	Accepted Wire Gauge	Max Insulation	553	18 – 26 AWG Solid or Stranded	2.2mm
Code	Accepted Wire Gauge	Max Insulation				
553	18 – 26 AWG Solid or Stranded	2.2mm				

<b>9</b>	<b>06</b>
Insulator Color 9 = UL White	Plating Option 06 = Tin Plated



## CURRENT RATING

<b>18AWG</b>	<b>20AWG</b>	<b>22AWG</b>	<b>24AWG</b>	<b>26AWG</b>
7A	6A	5A	4A	3A

Certification: UL File #E90723

# Poke-Home: Vertical Top Entry

## 18-26 AWG: WTB

00-9296

### 9296 TOP MOUNT POKE HOME CONNECTOR

#### 1 WAY

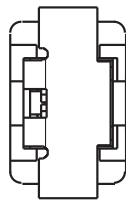
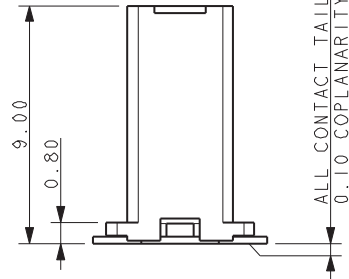
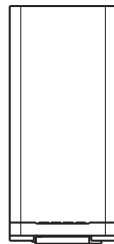
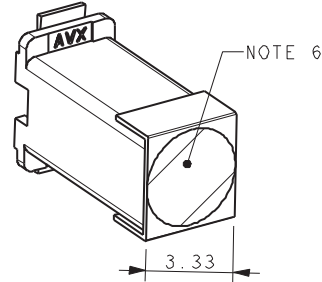
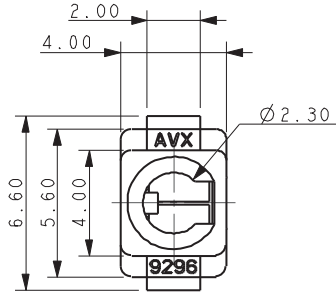

NOTES:

1. TOP MOUNT 1 WAY POKE HOME CONNECTOR. FOR FURTHER DETAILS REFER TO PRODUCT SPECIFICATION 201-01-151 AND APPLICATION NOTES 201-01-152.
2. SUITABLE FOR WIRES 18AWG TO 26AWG. MAXIMUM INSULATION 2.20MM DIAMETER.
3. INSULATOR: NYLON 46, GLASS FILLED, UL94 V-0. COLOR REFER TO PAGE 75.
4. CONTACT: TIN PLATE COPPER ALLOY.
5. PACKING IN TAPE AND REEL. QTY PER REEL 400, 330MM REEL.
6. CAPTON TAPE TO AID PICK AND PLACE, 4MM DIAMETER MAX AVAILABLE.
7. CONNECTOR OUTLINE.
8. GENERAL TOLERANCE  $\pm 0.20$ .

### PACKING DETAILS

### SUGGESTED PCB LAYOUT

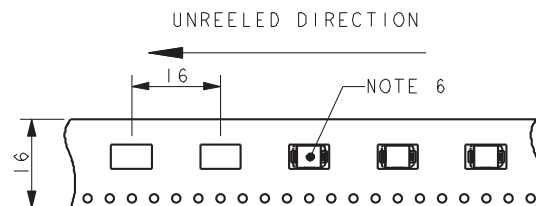
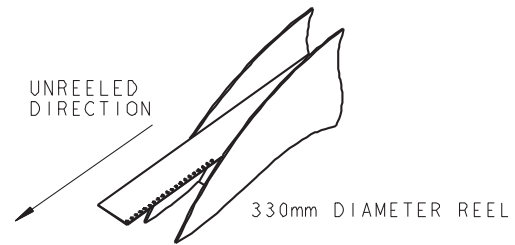
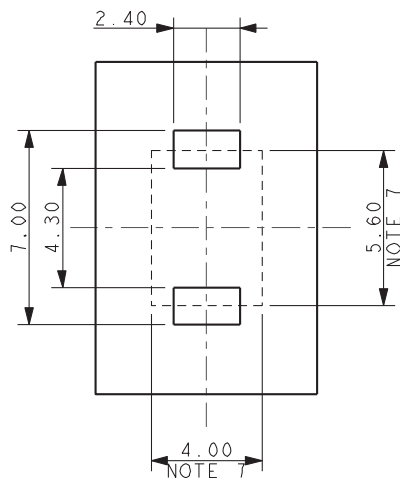

QUANTITY PER REEL 400

# Poke-Home: Vertical Top Entry 18-26 AWG: WTB

00-9296

## 9296 TOP MOUNT POKE HOME CONNECTOR 2 WAY

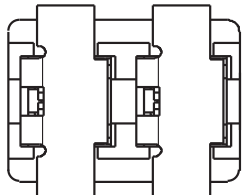
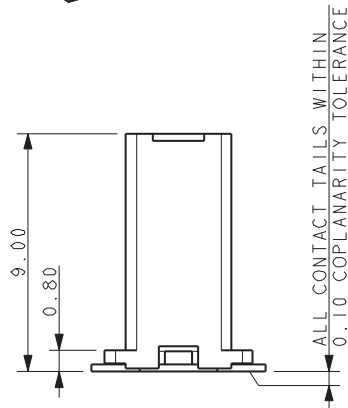
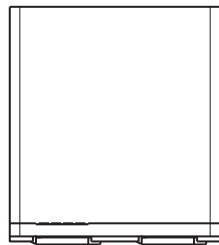
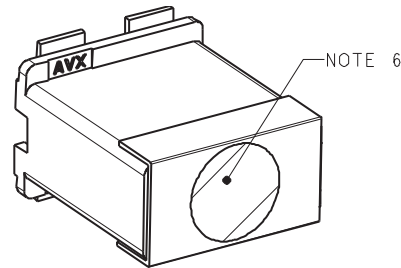
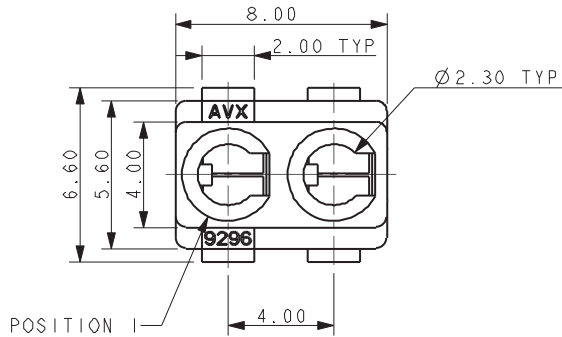

**NOTES:**

1. TOP MOUNT 2 WAY POKE HOME CONNECTOR. FOR FURTHER DETAILS REFER TO PRODUCT SPECIFICATION 201-01-151 AND APPLICATION NOTES 201-01-152.
2. SUITABLE FOR WIRES 18AWG TO 26AWG. MAXIMUM INSULATION 2.20MM DIAMETER.
3. INSULATOR: NYLON 46, GLASS FILLED, UL94 V-0. COLOR REFER TO PAGE 75.
4. CONTACT: TIN PLATE COPPER ALLOY.
5. PACKING IN TAPE AND REEL. QTY PER REEL 400, 330MM REEL.
6. CAPTON TAPE TO AID PICK AND PLACE, 4MM DIAMETER MAX AVAILABLE.
7. CONNECTOR OUTLINE.
8. GENERAL TOLERANCE  $\pm 0.20$ .

### PACKING DETAILS

### SUGGESTED PCB LAYOUT

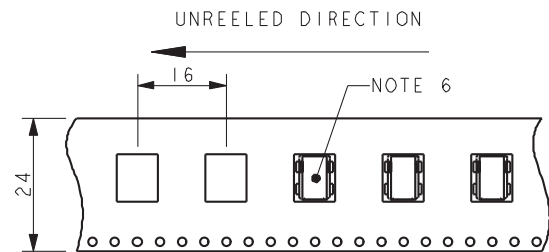
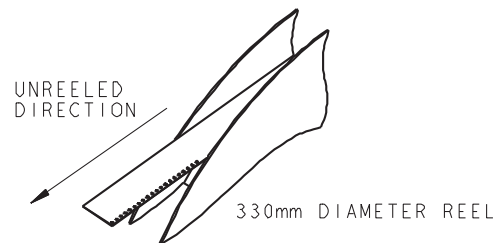
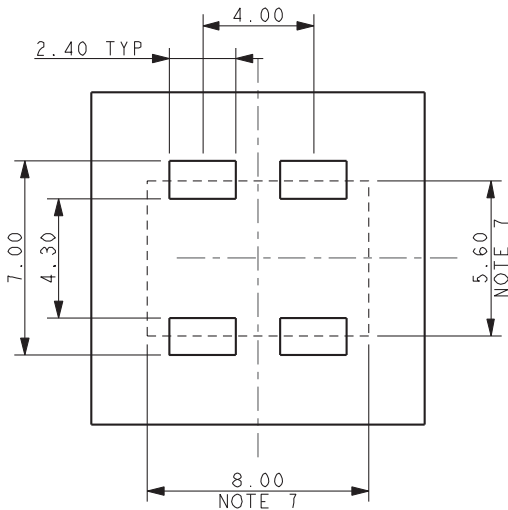

QUANTITY PER REEL 400

# Poke-Home: Vertical Top Entry 18-26 AWG: WTB

00-9296

## 9296 TOP MOUNT POKE HOME CONNECTOR 3 WAY

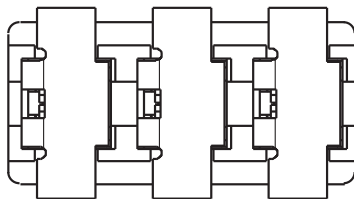
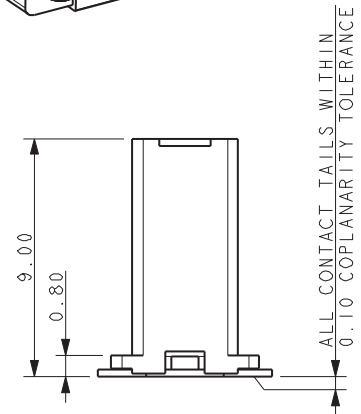
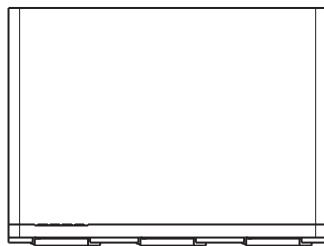
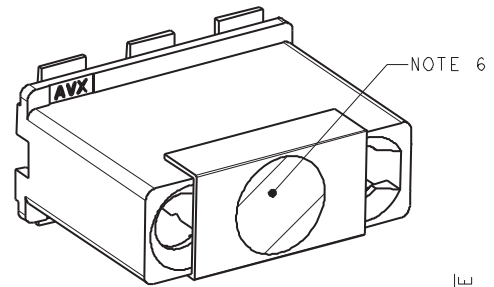
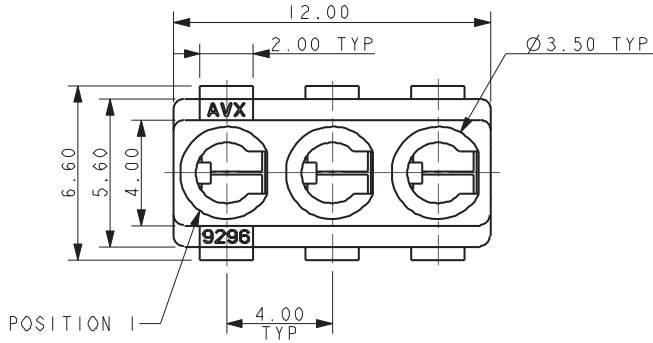

**NOTES:**

1. TOP MOUNT 3 WAY POKE HOME CONNECTOR. FOR FURTHER DETAILS REFER TO PRODUCT SPECIFICATION 201-01-151 AND APPLICATION NOTES 201-01-152.
2. SUITABLE FOR WIRES 18AWG TO 26AWG. MAXIMUM INSULATION 2.20MM DIAMETER.
3. INSULATOR: NYLON 46, GLASS FILLED, UL94 V-0. COLOR REFER TO PAGE 75.
4. CONTACT: TIN PLATE COPPER ALLOY.
5. PACKING IN TAPE AND REEL. QTY PER REEL 400, 330MM REEL.
6. CAPTON TAPE TO AID PICK AND PLACE, 4MM DIAMETER MAX AVAILABLE.
7. CONNECTOR OUTLINE.
8. GENERAL TOLERANCE  $\pm 0.20$ .

### SUGGESTED PCB LAYOUT

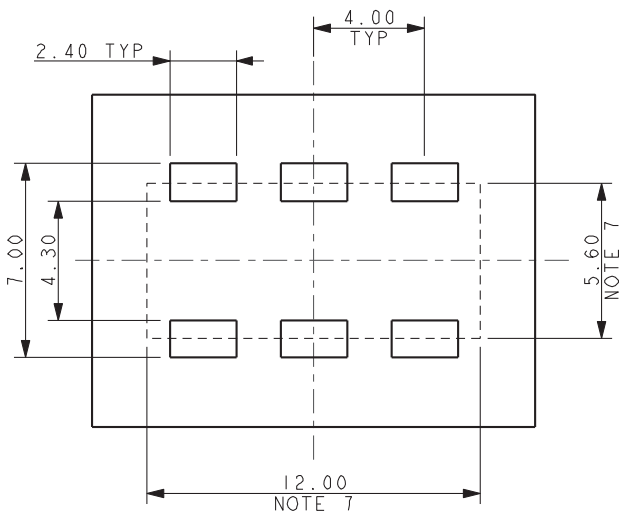

### PACKING DETAILS

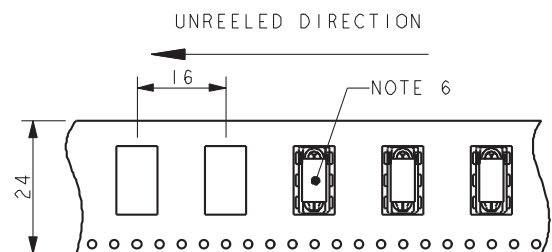
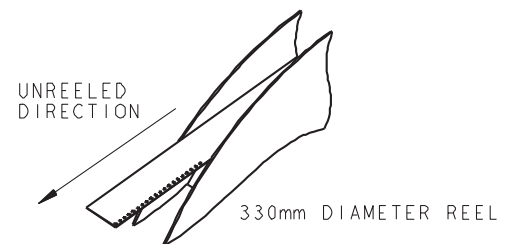

QUANTITY PER REEL 400

# Poke-Home: Vertical Top Entry 18-26 AWG: WTB

00-9296

## 9296 TOP MOUNT POKE HOME CONNECTOR

4 WAY

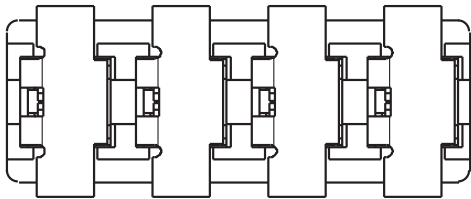
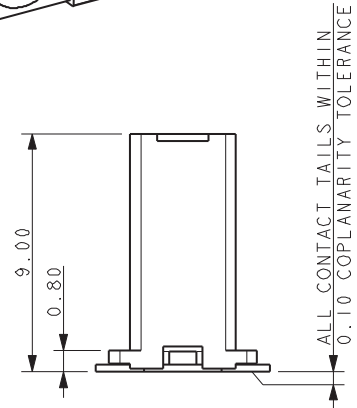
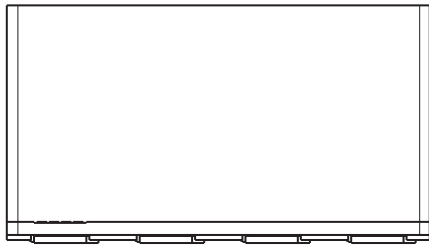
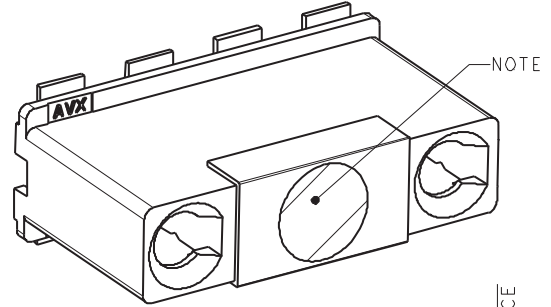
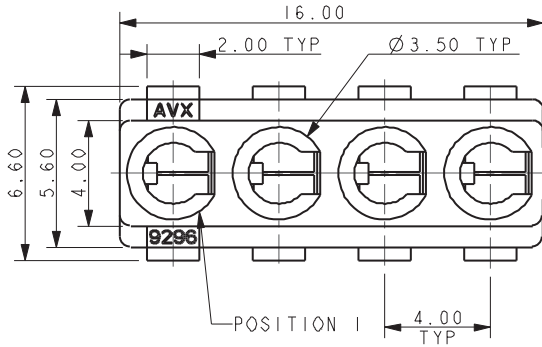

NOTES:

1. TOP MOUNT 4 WAY POKE HOME CONNECTOR. FOR FURTHER DETAILS REFER TO PRODUCT SPECIFICATION 201-01-151 AND APPLICATION NOTES 201-01-152.
2. SUITABLE FOR WIRES 18AWG TO 26AWG. MAXIMUM INSULATION 2.20MM DIAMETER.
3. INSULATOR: NYLON 46, GLASS FILLED, UL94 V-0. COLOR REFER TO PAGE 75.
4. CONTACT: TIN PLATE COPPER ALLOY.
5. PACKING IN TAPE AND REEL. QTY PER REEL 400, 330MM REEL.
6. CAPTON TAPE TO AID PICK AND PLACE, 4MM DIAMETER MAX AVAILABLE.
7. CONNECTOR OUTLINE.
8. GENERAL TOLERANCE  $\pm 0.20$ .

### SUGGESTED PCB LAYOUT

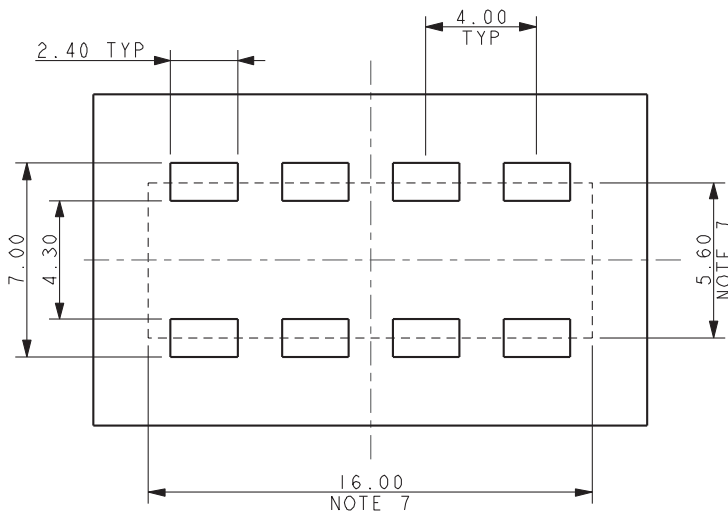

### PACKING DETAILS

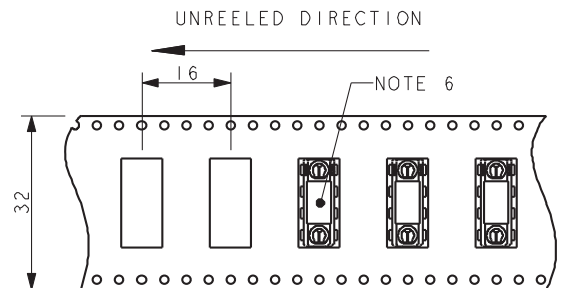
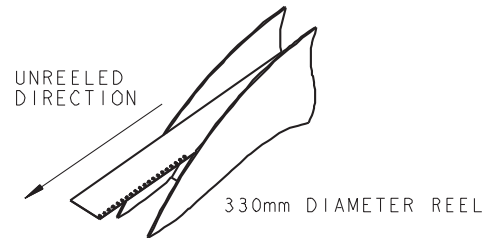

QUANTITY PER REEL 400



# Poke-Home: Vertical Top Entry

## 18-26 AWG: WTB

00-9296

### 9296 TOP MOUNT POKE HOME CONNECTOR

5 WAY

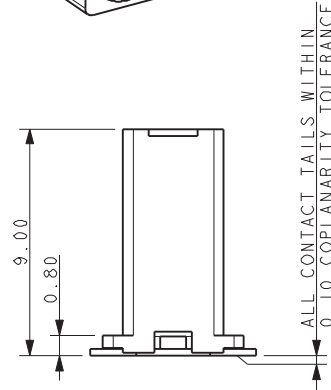
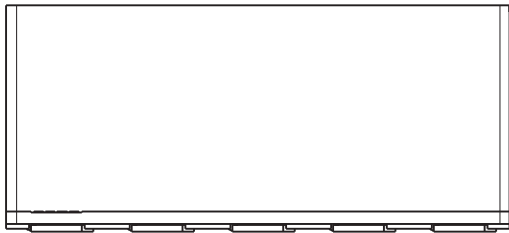
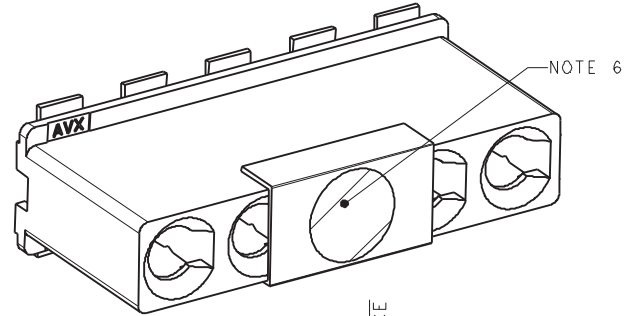
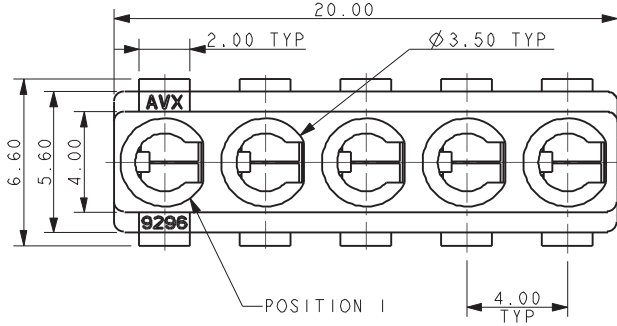

NOTES:

1. TOP MOUNT 5 WAY POKE HOME CONNECTOR. FOR FURTHER DETAILS REFER TO PRODUCT SPECIFICATION 201-01-151 AND APPLICATION NOTES 201-01-152.
2. SUITABLE FOR WIRES 18AWG TO 26AWG. MAXIMUM INSULATION 2.20MM DIAMETER.
3. INSULATOR: NYLON 46, GLASS FILLED, UL94 V-0. COLOR REFER TO PAGE 75.
4. CONTACT: TIN PLATE COPPER ALLOY.
5. PACKING IN TAPE AND REEL. QTY PER REEL 400, 330MM REEL.
6. CAPTON TAPE TO AID PICK AND PLACE, 4MM DIAMETER MAX AVAILABLE.
7. CONNECTOR OUTLINE.
8. GENERAL TOLERANCE  $\pm 0.20$ .

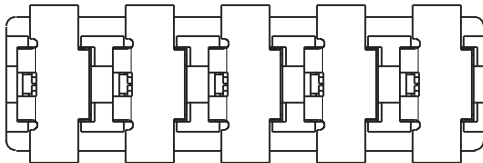

### SUGGESTED PCB LAYOUT

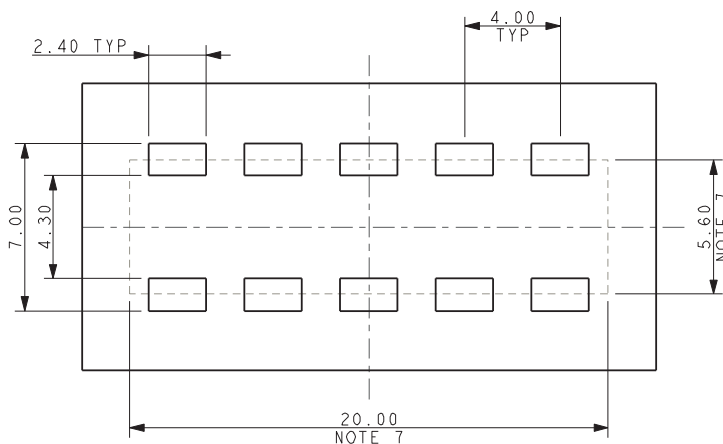

### PACKING DETAILS

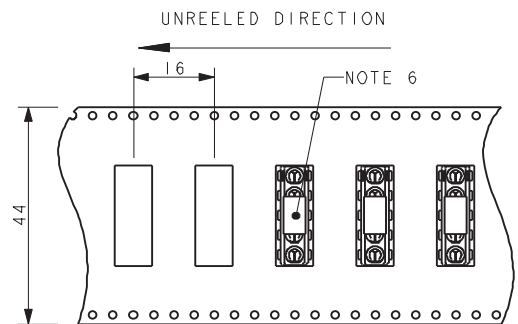
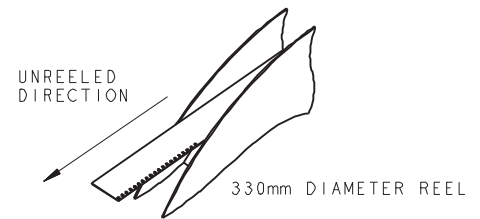

QUANTITY PER REEL 400

# Poke-Home: Vertical Top Entry 18-26 AWG: WTB

00-9296

## 9296 TOP MOUNT POKE HOME CONNECTOR

6 WAY

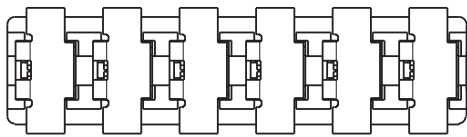
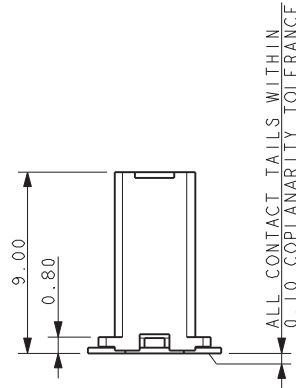
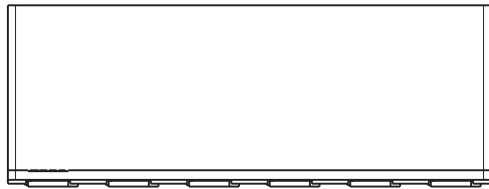
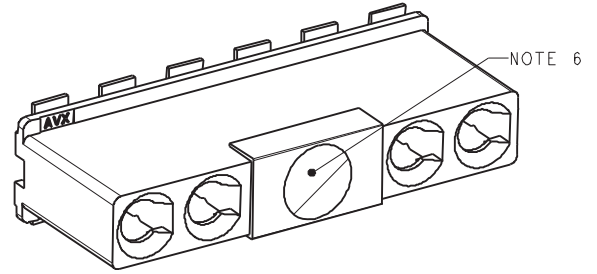
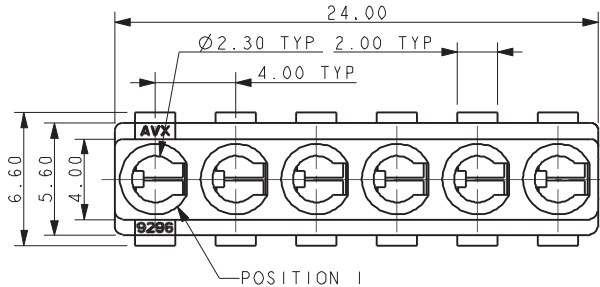

**NOTES:**

1. TOP MOUNT 6 WAY POKE HOME CONNECTOR. FOR FURTHER DETAILS REFER TO PRODUCT SPECIFICATION 201-01-151 AND APPLICATION NOTES 201-01-152.
2. SUITABLE FOR WIRES 18AWG TO 26AWG. MAXIMUM INSULATION 2.20MM DIAMETER.
3. INSULATOR: NYLON 46, GLASS FILLED, UL94 V-0. COLOR REFER TO PAGE 75.
4. CONTACT: TIN PLATE COPPER ALLOY.
5. PACKING IN TAPE AND REEL. QTY PER REEL 400, 330MM REEL.
6. CAPTON TAPE TO AID PICK AND PLACE, 4MM DIAMETER MAX AVAILABLE.
7. CONNECTOR OUTLINE.
8. GENERAL TOLERANCE  $\pm 0.20$ .

### SUGGESTED PCB LAYOUT

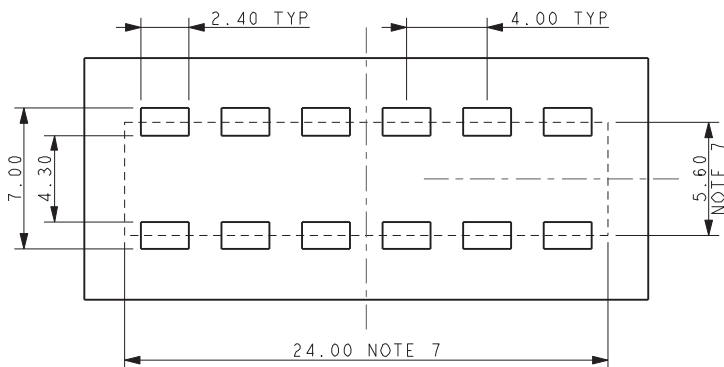

### PACKING DETAILS

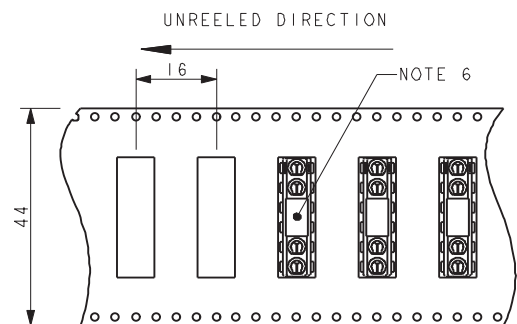
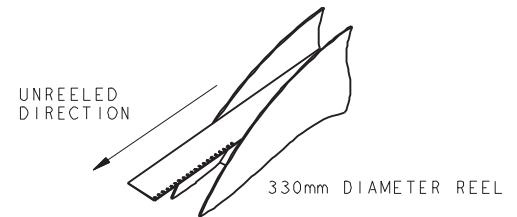

QUANTITY PER REEL 400

# Poke-Home: Vertical Top Entry 18-26 AWG: WTB

00-9296

## 9296 TOP MOUNT POKE HOME CONNECTOR ASSEMBLY

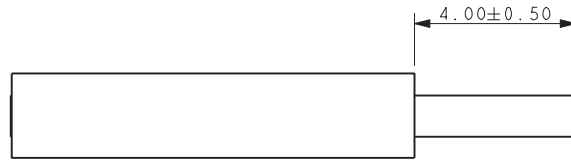

WIRE STRIP LENGTH

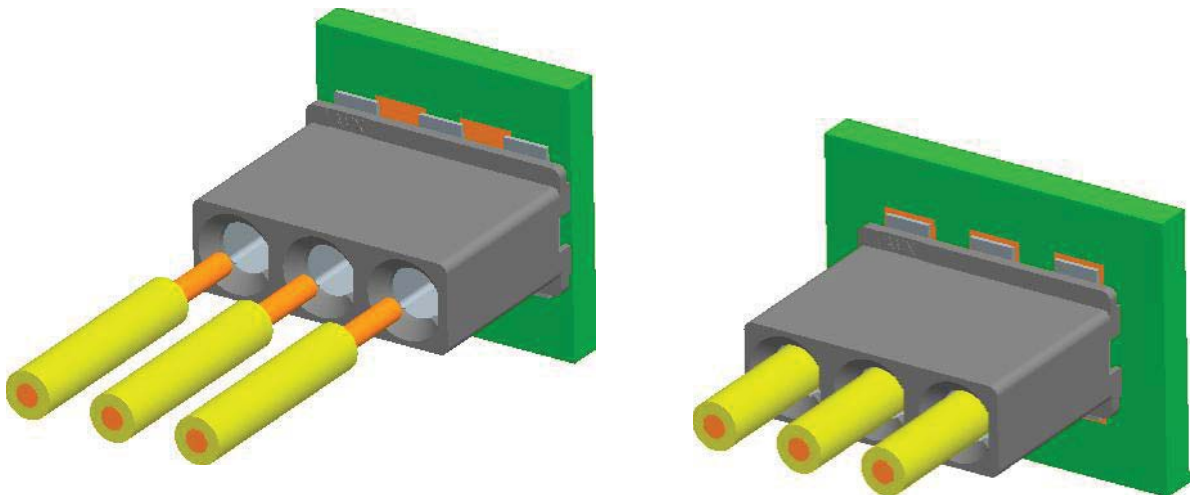

*Refer to application notes 201-01-152  
for full assembly procedure*

## 9296 TOP MOUNT POKE HOME CONNECTOR WIRE EXTRACTION TOOL

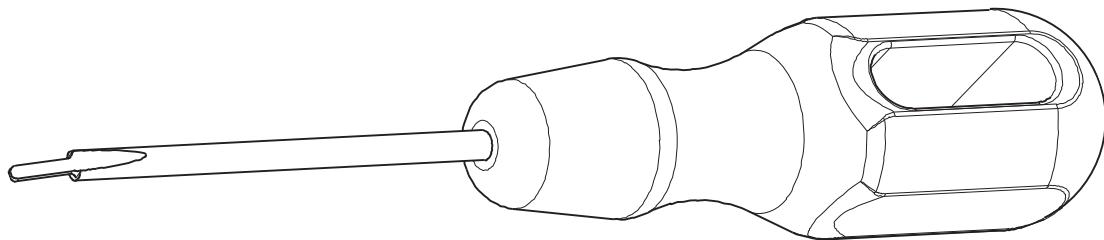

06-9296-7003-01-000

*Refer to application notes 201-01-152  
for full wire extraction procedure*

# Poke-Home: Inverted Thru Board 18-26 AWG: WTB

00-9296



AVX continues to develop innovative connectors for the industrial electronics market that provide significant benefits over existing, outdated connector solutions. Listening to the design engineering community, there are ongoing applications where they cannot find an off-the-shelf solution that will satisfy a high percentage of the projects configuration, performance and cost goals.

The newest addition to AVX's broadening line of Wire-to-Board (WTB) connectors offers a cost effective, single Poke-Home connector solution that will meet the cost and performance targets in demanding, yet user friendly applications. At the heart of the connector is the industry proven dual tine, 3mm high spring force box contact that has been on the market as a stand-alone horizontal contact only solution.

The new SMT vertical through board connector allows for 18AWG to 26AWG wires to be simply stripped and inserted into the connector body at 180 degree orientation to the bottom side of the PCB with an above board height of 0.80mm. This single connector will replace existing 2-Piece WTB solutions where a header is soldered onto the PCB and a secondary crimp-to-wire receptacle assembly is plugged in. Available in 1-6 positions, each connector will accept the entire wire gauge range for either solid or stranded wires at varying current ratings supported by each wire size. Once inserted, wires can easily be removed or replaced by twisting/unscrewing or by using a small blade extraction tool.

## APPLICATIONS

- Industrial/Ruggedized Wire-to-Board applications
- Replace hard soldering of wire to a PCB
- Replace costly 2-Piece header and receptacle products
- Reference Product Specification 201-01-151
- Reference Application Notes 201-01-152

## FEATURES AND BENEFITS

- Dual Beam box contact provides maximum mechanical stability and wire retention
- Tape and reel packaged for automated SMT placement
- Will accept either solid or stranded wire, 18-26AWG, plated or un-plated wires
- Simple strip and insert for wire loading, with easy twist and pull for wire removal

## ELECTRICAL

- Voltage Rating: 200 VAC
- Current Rating: See matrix below

## ENVIRONMENTAL

- Operating Temperature: -40°C to +125°C

## MECHANICAL

- Contact Material: Copper Alloy
- Contact Plating: Tin over Nickel
- Durability: 5 Cycles

## HOW TO ORDER

<b>00</b>	<b>9296</b>	<b>00X</b>																					
Prefix	Series	Number of Ways																					
		<table border="1"> <thead> <tr> <th>Code</th> <th>No of Ways</th> <th>Details</th> </tr> </thead> <tbody> <tr><td>001</td><td>1</td><td>Page 84</td></tr> <tr><td>002</td><td>2</td><td>Page 85</td></tr> <tr><td>003</td><td>3</td><td>Page 86</td></tr> <tr><td>004</td><td>4</td><td>Page 87</td></tr> <tr><td>005</td><td>5</td><td>Page 88</td></tr> <tr><td>006</td><td>6</td><td>Page 89</td></tr> </tbody> </table>	Code	No of Ways	Details	001	1	Page 84	002	2	Page 85	003	3	Page 86	004	4	Page 87	005	5	Page 88	006	6	Page 89
Code	No of Ways	Details																					
001	1	Page 84																					
002	2	Page 85																					
003	3	Page 86																					
004	4	Page 87																					
005	5	Page 88																					
006	6	Page 89																					

<b>503</b>
Wire Gauge Size

Code	Accepted Wire Gauge	Max Insulation
503	18 – 26 AWG Solid or Stranded	2.2mm

<b>9</b>
Insulator Color
9 = UL White

<b>06</b>
Plating Option
06 = Tin Plated



## CURRENT RATING

18AWG	20AWG	22AWG	24AWG	26AWG
7A	6A	5A	4A	3A

Certification: UL File #E90723

# Poke-Home: Inverted Thru Board 18-26 AWG: WTB

00-9296

## 9296 THROUGH BOARD MOUNT POKE HOME CONNECTOR

### 1 WAY

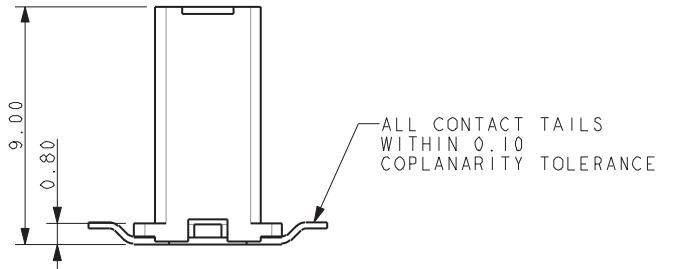
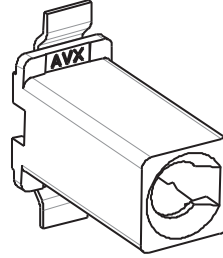
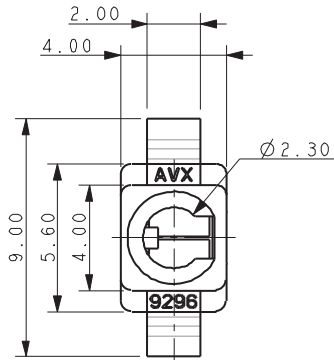

PICK AND PLACE  
2.1mm DIAMETER

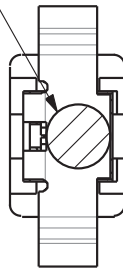

#### NOTES:

1. THROUGH BOARD SMT MOUNT 1 WAY POKE HOME CONNECTOR. FOR FURTHER DETAILS REFER TO PRODUCT SPECIFICATION 201-01-151 AND APPLICATION NOTES 201-01-152.
2. SUITABLE FOR WIRES 18AWG TO 26AWG. MAXIMUM INSULATION 2.20MM DIAMETER.
3. INSULATOR: NYLON 46, GLASS FILLED, UL94 V-0. COLOR REFER TO PAGE 83.
4. CONTACT: TIN PLATE COPPER ALLOY.
5. PACKING IN TAPE AND REEL. QTY PER REEL 400, 330MM REEL.
6. GENERAL TOLERANCE  $\pm 0.20$ .
7. CLEARANCE HOLE FOR CONNECTOR.
8. UL REFERENCE E90723

### PACKING DETAILS

### SUGGESTED PCB LAYOUT

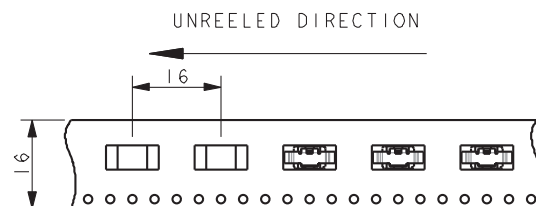
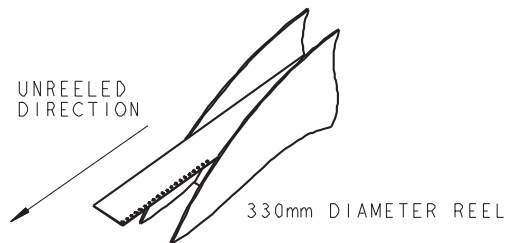
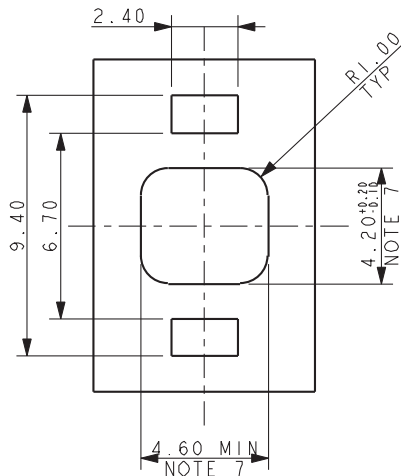

QUANTITY PER REEL 400

# Poke-Home: Inverted Thru Board 18-26 AWG: WTB

00-9296

## 9296 THROUGH BOARD MOUNT POKE HOME CONNECTOR 2 WAY

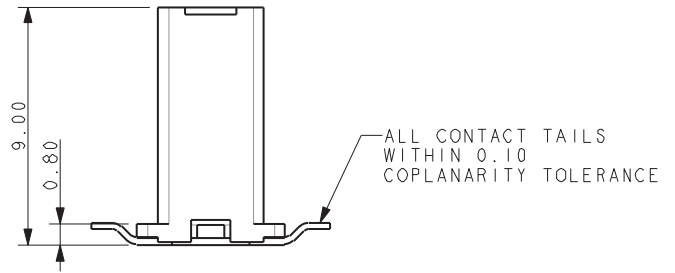
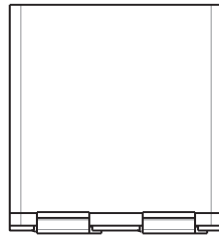
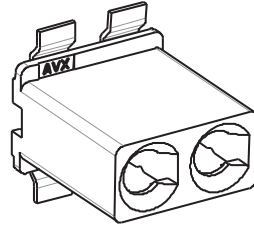
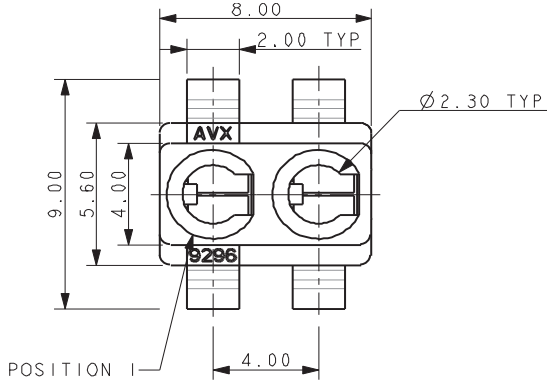

PICK AND PLACE  
2.1mm DIAMETER

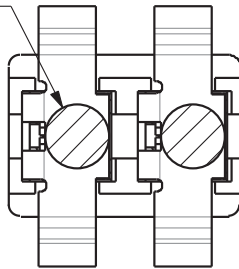

### NOTES:

1. THROUGH BOARD SMT MOUNT 2 WAY POKE HOME CONNECTOR. FOR FURTHER DETAILS REFER TO PRODUCT SPECIFICATION 201-01-151 AND APPLICATION NOTES 201-01-152.
2. SUITABLE FOR WIRES 18AWG TO 26AWG. MAXIMUM INSULATION 2.20MM DIAMETER.
3. INSULATOR: NYLON 46, GLASS FILLED, UL94 V-0. COLOR REFER TO PAGE 83.
4. CONTACT: TIN PLATE COPPER ALLOY.
5. PACKING IN TAPE AND REEL. QTY PER REEL 400, 330MM REEL.
6. GENERAL TOLERANCE  $\pm 0.20$ .
7. CLEARANCE HOLE FOR CONNECTOR.
8. UL REFERENCE E90723

### PACKING DETAILS

### SUGGESTED PCB LAYOUT

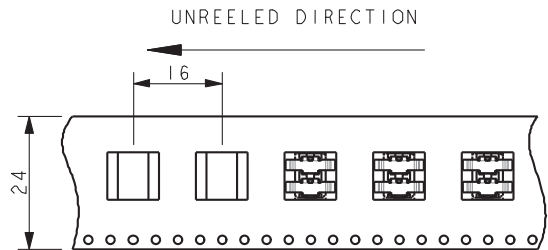
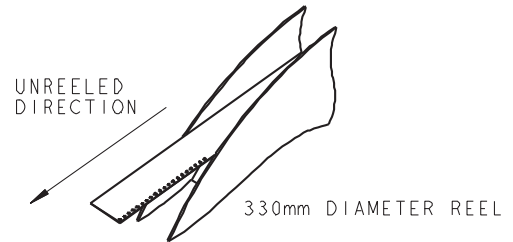
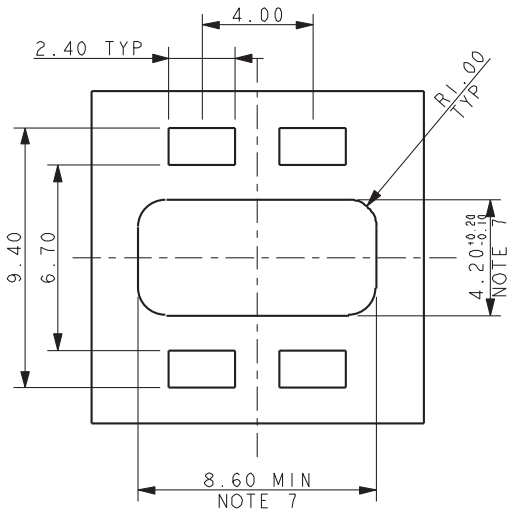

QUANTITY PER REEL 400

# Poke-Home: Inverted Thru Board 18-26 AWG: WTB

00-9296

## 9296 THROUGH BOARD MOUNT POKE HOME CONNECTOR 3 WAY

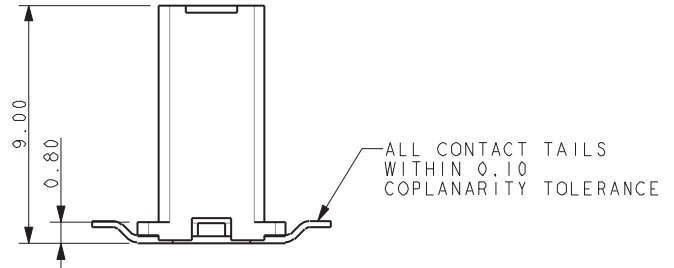
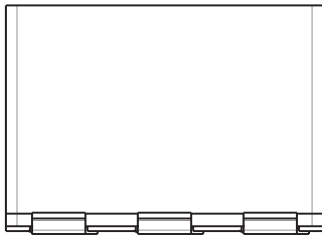
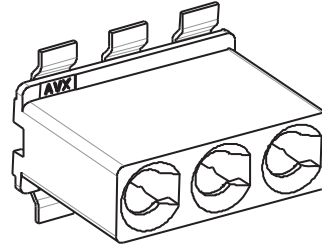
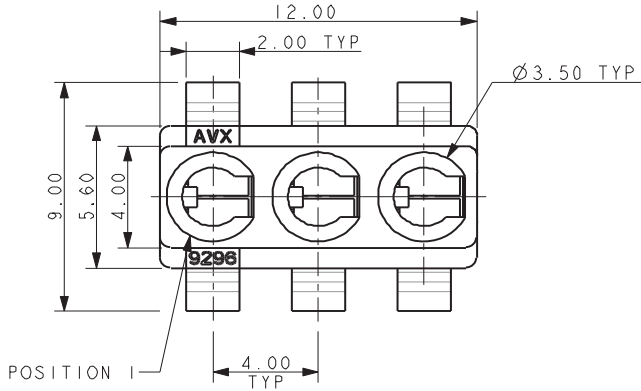

PICK AND PLACE  
2.1mm DIAMETER

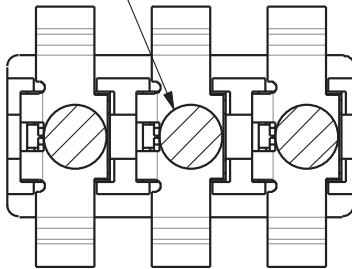

### NOTES:

1. THROUGH BOARD SMT MOUNT 3 WAY POKE HOME CONNECTOR. FOR FURTHER DETAILS REFER TO PRODUCT SPECIFICATION 201-01-151 AND APPLICATION NOTES 201-01-152.
2. SUITABLE FOR WIRES 18AWG TO 26AWG. MAXIMUM INSULATION 2.20MM DIAMETER.
3. INSULATOR: NYLON 46, GLASS FILLED, UL94 V-0. COLOR REFER TO PAGE 83.
4. CONTACT: TIN PLATE COPPER ALLOY.
5. PACKING IN TAPE AND REEL. QTY PER REEL 400, 330MM REEL.
6. GENERAL TOLERANCE  $\pm 0.20$ .
7. CLEARANCE HOLE FOR CONNECTOR.
8. UL REFERENCE E90723

### SUGGESTED PCB LAYOUT

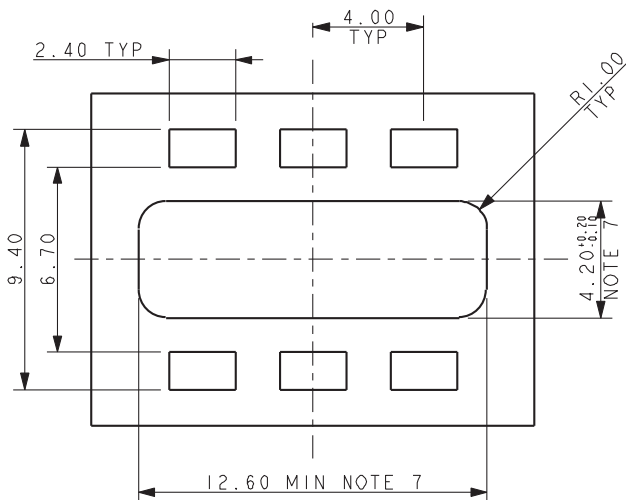

### PACKING DETAILS

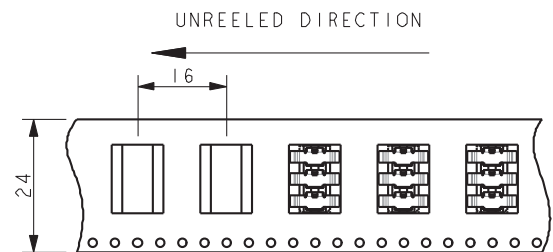
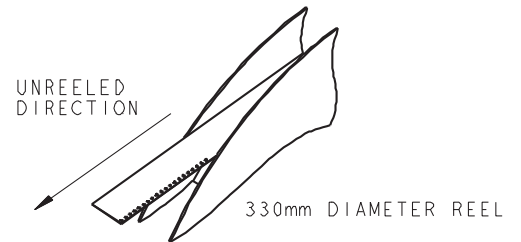

QUANTITY PER REEL 400

# Poke-Home: Inverted Thru Board 18-26 AWG: WTB

00-9296

## 9296 THROUGH BOARD MOUNT POKE HOME CONNECTOR

4 WAY

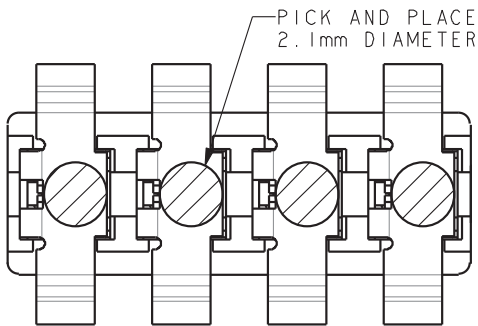
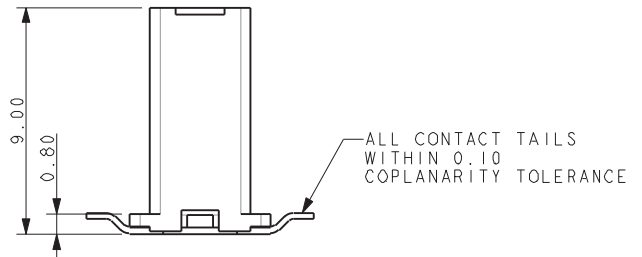
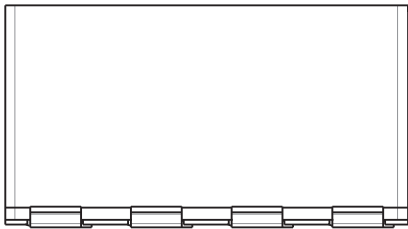
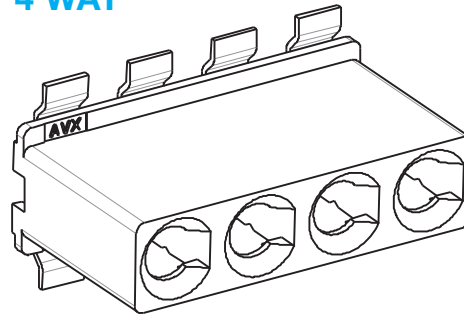
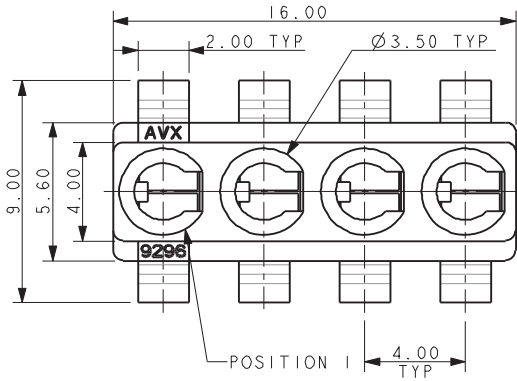

**NOTES:**

1. THROUGH BOARD SMT MOUNT 4 WAY POKE HOME CONNECTOR. FOR FURTHER DETAILS REFER TO PRODUCT SPECIFICATION 201-01-151 AND APPLICATION NOTES 201-01-152.
2. SUITABLE FOR WIRES 18AWG TO 26AWG. MAXIMUM INSULATION 2.20MM DIAMETER.
3. INSULATOR: NYLON 46, GLASS FILLED, UL94 V-0. COLOR REFER TO PAGE 83.
4. CONTACT: TIN PLATE COPPER ALLOY.
5. PACKING IN TAPE AND REEL. QTY PER REEL 400, 330MM REEL.
6. GENERAL TOLERANCE  $\pm 0.20$ .
7. CLEARANCE HOLE FOR CONNECTOR.
8. UL REFERENCE E90723

### PACKING DETAILS

### SUGGESTED PCB LAYOUT

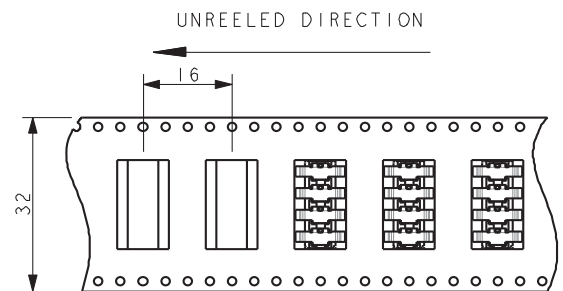
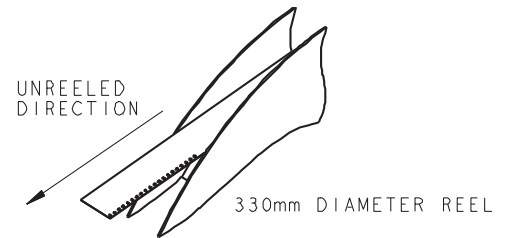
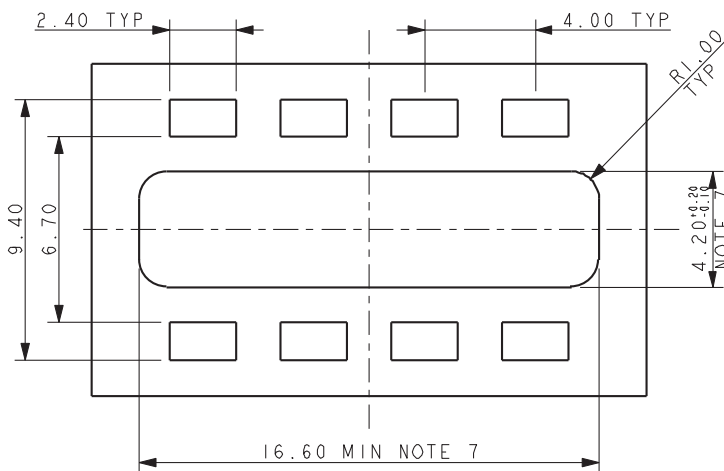

QUANTITY PER REEL 400



# Poke-Home: Inverted Thru Board 18-26 AWG: WTB

00-9296

## 9296 THROUGH BOARD MOUNT POKE HOME CONNECTOR 5 WAY

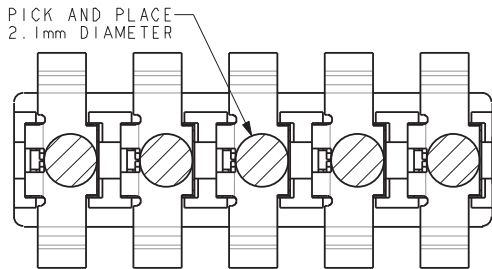
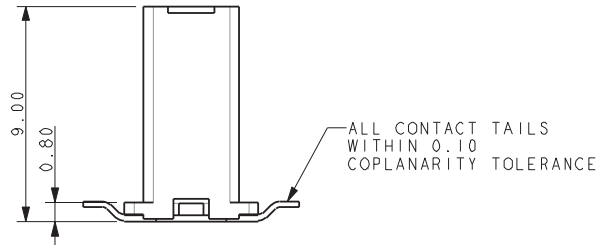
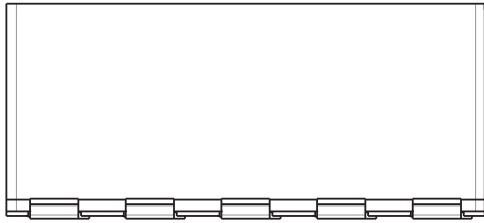
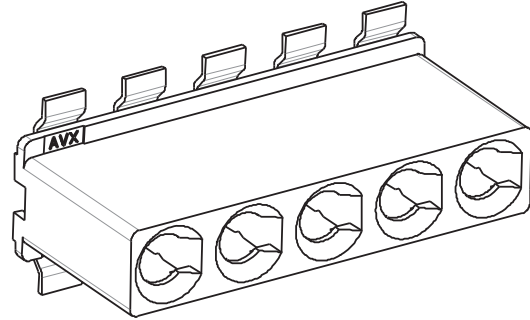
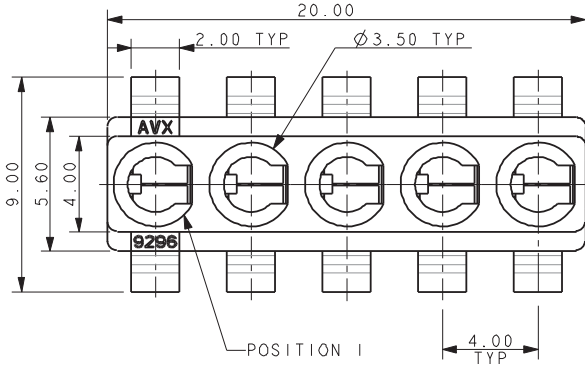

**NOTES:**

1. THROUGH BOARD SMT MOUNT 5 WAY POKE HOME CONNECTOR. FOR FURTHER DETAILS REFER TO PRODUCT SPECIFICATION 201-01-151 AND APPLICATION NOTES 201-01-152.
2. SUITABLE FOR WIRES 18AWG TO 26AWG. MAXIMUM INSULATION 2.20MM DIAMETER.
3. INSULATOR: NYLON 46, GLASS FILLED, UL94 V-0. COLOR REFER TO PAGE 83.
4. CONTACT: TIN PLATE COPPER ALLOY.
5. PACKING IN TAPE AND REEL. QTY PER REEL 400, 330MM REEL.
6. GENERAL TOLERANCE  $\pm 0.20$ .
7. CLEARANCE HOLE FOR CONNECTOR.
8. UL REFERENCE E90723

### SUGGESTED PCB LAYOUT

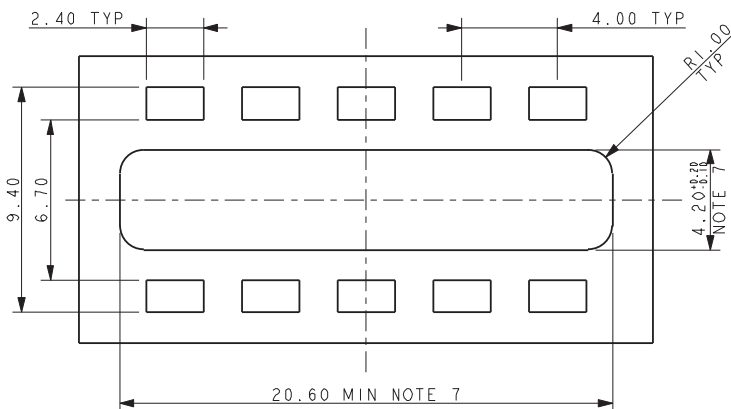

### PACKING DETAILS

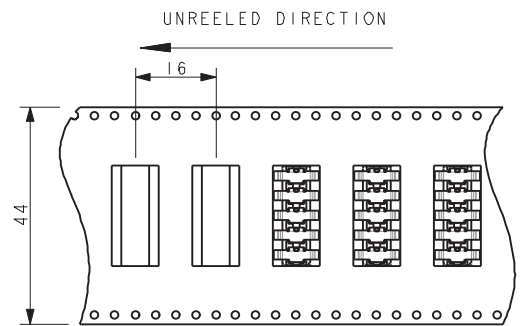
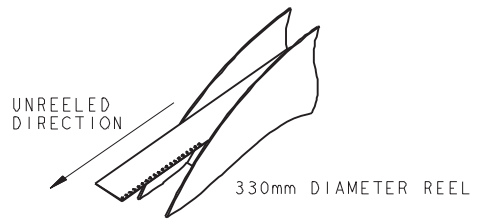

QUANTITY PER REEL 400

# Poke-Home: Inverted Thru Board 18-26 AWG: WTB

00-9296

## 9296 THROUGH BOARD MOUNT POKE HOME CONNECTOR

6 WAY

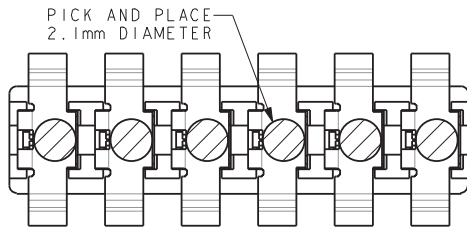
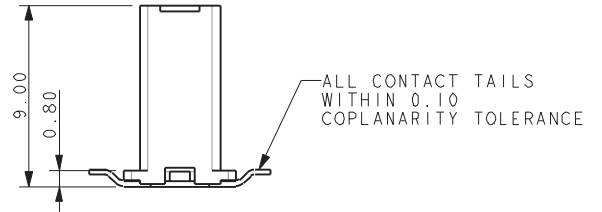
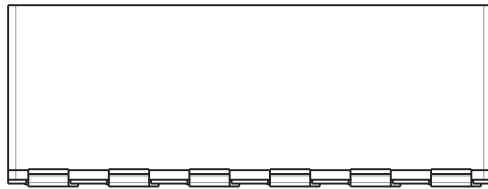
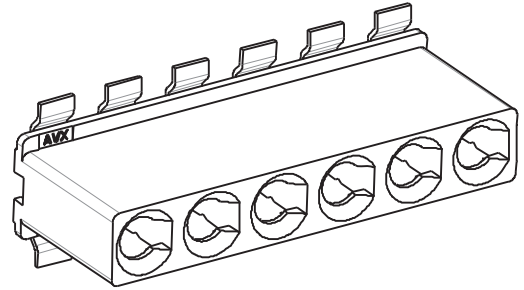
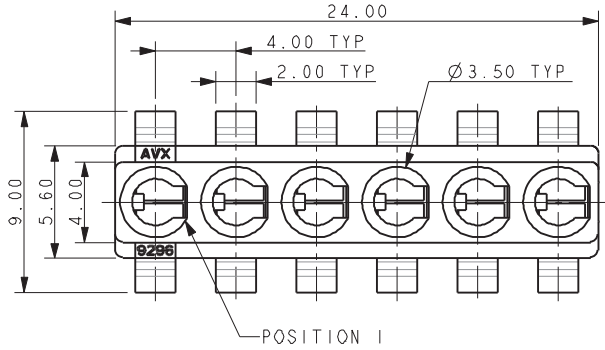

**NOTES:**

1. THROUGH BOARD SMT MOUNT 6 WAY POKE HOME CONNECTOR. FOR FURTHER DETAILS REFER TO PRODUCT SPECIFICATION 201-01-151 AND APPLICATION NOTES 201-01-152.
2. SUITABLE FOR WIRES 18AWG TO 26AWG. MAXIMUM INSULATION 2.20MM DIAMETER.
3. INSULATOR: NYLON 46, GLASS FILLED, UL94 V-0. COLOR REFER TO PAGE 83.
4. CONTACT: TIN PLATE COPPER ALLOY.
5. PACKING IN TAPE AND REEL. QTY PER REEL 400, 330MM REEL.
6. GENERAL TOLERANCE  $\pm 0.20$ .
7. CLEARANCE HOLE FOR CONNECTOR.
8. UL REFERENCE E90723

### SUGGESTED PCB LAYOUT

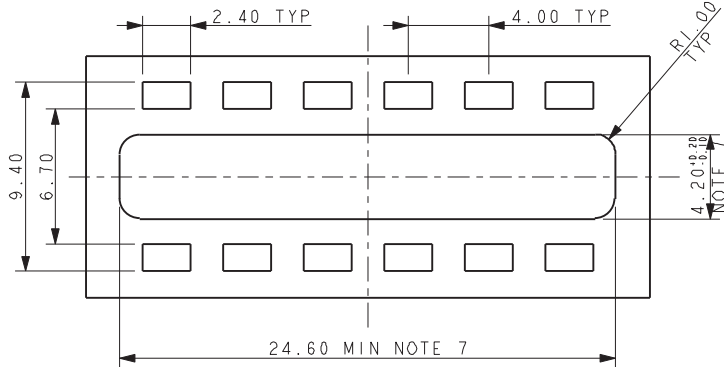

### PACKING DETAILS

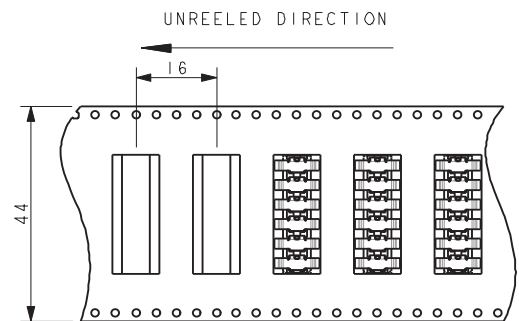
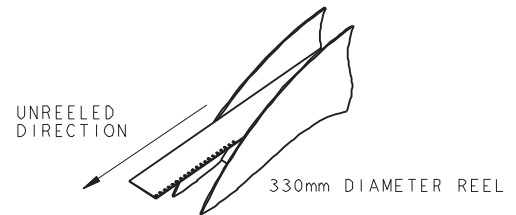

QUANTITY PER REEL 400

# Poke-Home: Inverted Thru Board 18-26 AWG: WTB

00-9296

## 9296 THROUGH BOARD MOUNT POKE HOME CONNECTOR ASSEMBLY

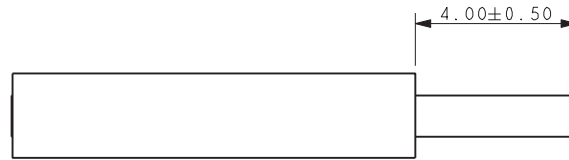

WIRE STRIP LENGTH

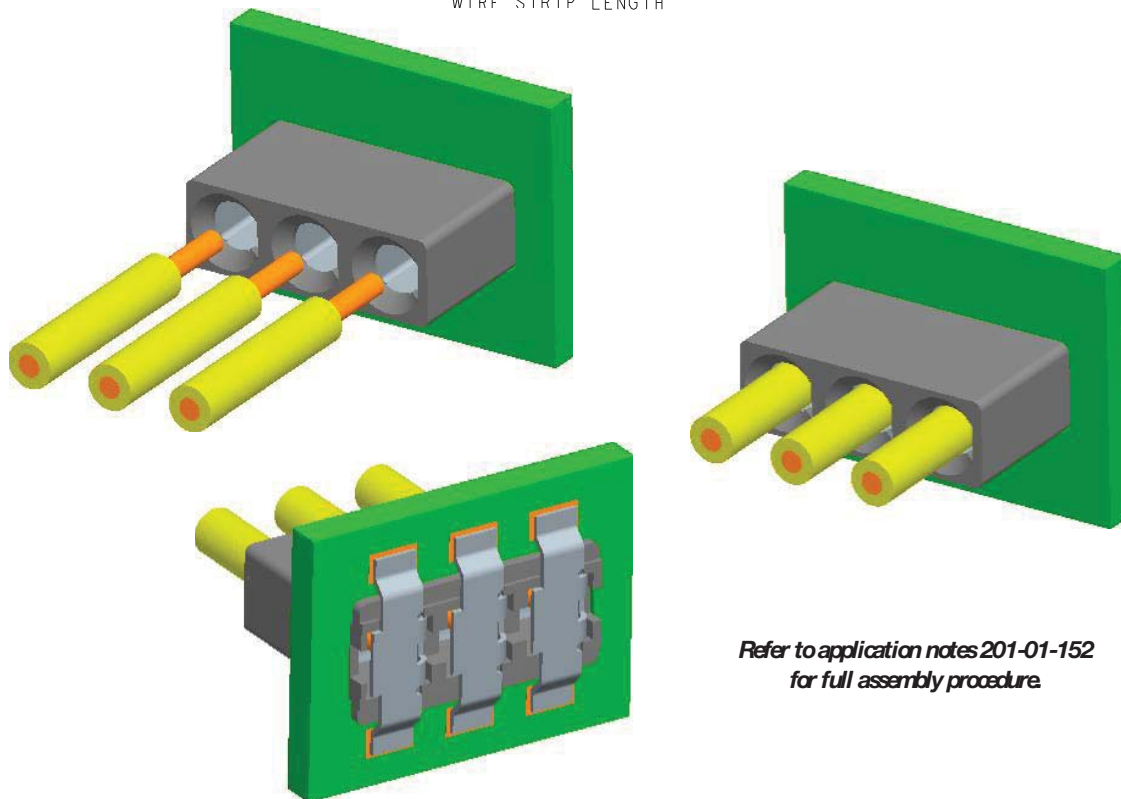

*Refer to application notes 201-01-152  
for full assembly procedure.*

## 9296 THROUGH BOARD MOUNT POKE HOME CONNECTOR WIRE EXTRACTION TOOL

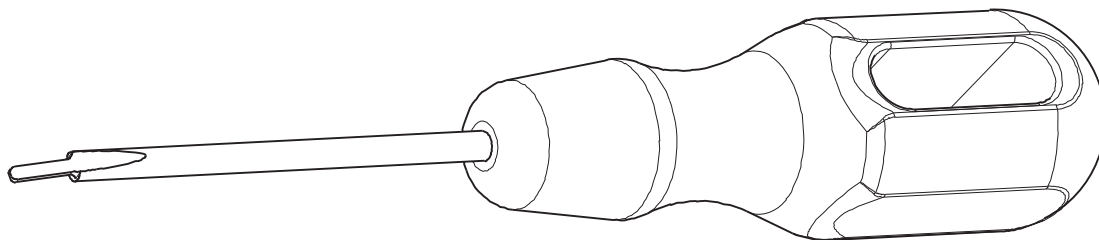

PLASTIC TOOL: 06-9296-7003-01-000  
METAL TOOL: 06-9296-7004-03-000

*Refer to application notes 201-01-152 for full wire extraction procedure.*

# Poke-Home: Single Vertical Contact

## 18-26 AWG: WTB

70-9296

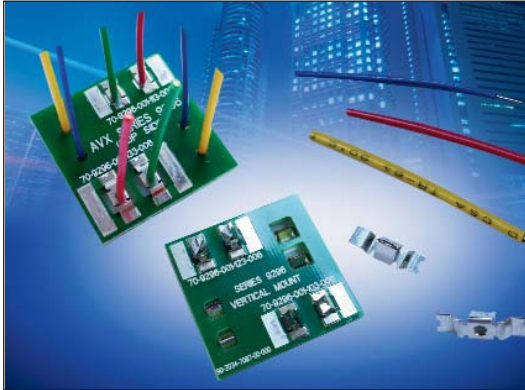

AVX continues to develop innovative connectors for the industrial electronics market that provide significant benefits over existing, outdated connector solutions. The latest release is single vertical Wire-to-Board (WTB) contacts that provide cost effective, yet robust discrete wire termination without the expense of an insulator and assembly costs. This new family of top and bottom entry contacts compliments the existing vertical poke home connectors already on the market, providing a lower cost solution without jeopardizing performance.

The new contacts support both solid and stranded wires ranging from 26AWG down to 18AWG and current ratings as high as 12 amps. The set of four contacts provide both top and bottom entry for FR4 and metal core printed circuit boards.

### APPLICATIONS

- Machine Controls: motors, drives, solenoids, sensors, fans and pumps
- Commercial Buildings: controls, security, fire and sensors
- Smart Grid: meters, breakers and panels
- SSL/LED; bulbs, fixtures, signage and streetlights

### FEATURES AND BENEFITS

- Dual Beam contact provides maximum mechanical stability and wire retention
- Tape and reel packaged for automated SMT placement
- Staged current rating based on AWG, maximum is 12A (18AWG)
- Increased functionality with the single contact placement: multiple contacts and/or specific individual locations

### ELECTRICAL

- Voltage Rating: 300V  
Based on placement distance
- Current Rating: See matrix below

### ENVIRONMENTAL

- Operating Temperature:  
-40°C to +125°C

### MECHANICAL

- Contact Material: Phosphor Bronze
- Contact Plating: Tin over Nickel
- Durability: 5 Cycles

### HOW TO ORDER

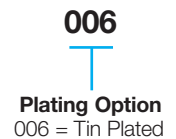

Code	Contact Location	Wire Insertion Direction	Recommended For Board Type	Accepted Wire Gauges
103	Top Side	Bottom Entry	FR4	18 – 26 AWG Solid or Stranded
113	Through Board	Top Entry	FR4	18 – 26 AWG Solid or Stranded
123	Top Side	Bottom Entry	Metal Clad	18 – 26 AWG Solid or Stranded
133	Through Board	Top Entry	Metal Clad	18 – 26 AWG Solid or Stranded



### CURRENT RATING

18AWG	20AWG	22AWG	24AWG	26AWG
15A	14A	10A	9A	7A

Certification: UL File #E90723

# Poke-Home: Single Vertical Contact

## 18-26 AWG: WTB

70-9296

70-9296-001-103-006

### 9296 VERTICAL MOUNT SMT CONTACT

#### TOP SIDE CONTACT – BOTTOM ENTRY WIRE (FR4 BOARD)

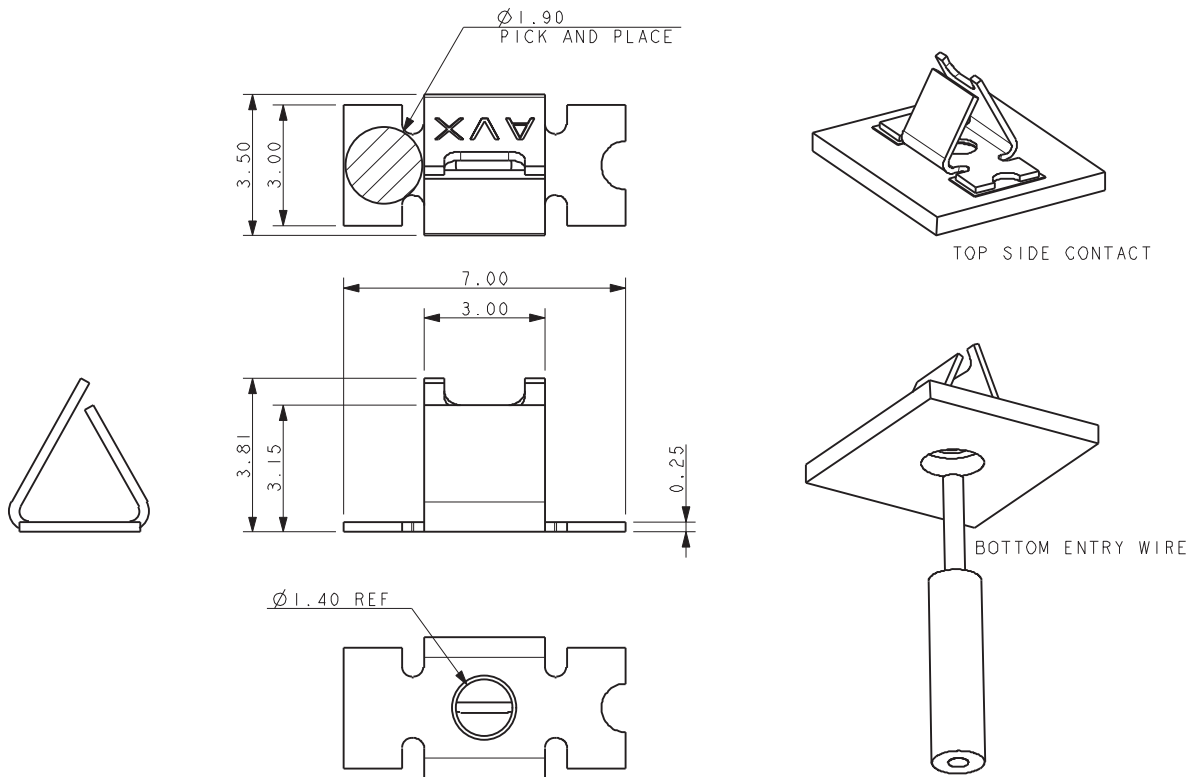

### SUGGESTED PCB LAYOUT

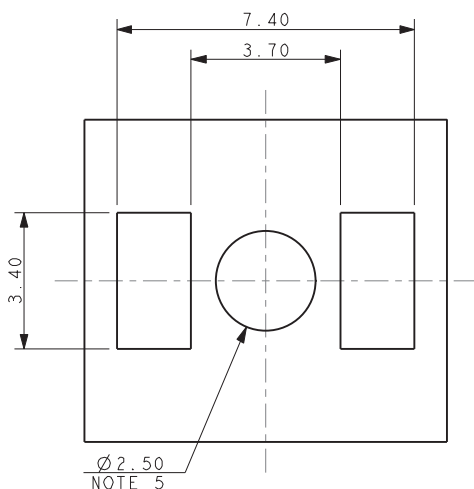

#### NOTES:

1. CONTACT MOUNTS ON TOP SIDE OF BOARD, WIRE INSERTED FROM UNDER-SIDE OF BOARD.
2. STYLE RECOMMENDED FOR FR4 BOARDS WHERE MINIMUM CLEARANCE REQUIRED TO CONTACT AND MOUNTING PADS.
3. FOR FURTHER INFORMATION REFER TO ELCO SPECIFICATION 201-01-143 AND APPLICATION NOTES 201-01-150.
4. MATERIAL: TIN PLATED PHOSPHOR BRONZE.
5. HOLE FOR WIRE INSERTION.
6. PACING IN TAPE AND REEL, 2000 PIECES PER REEL.
7. FOR WIRE TRIM DETAILS REFER TO PAGE 96.

### PACKING DETAILS

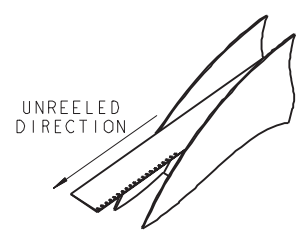
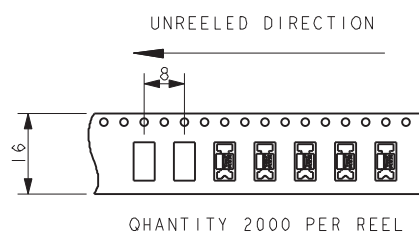

330mm DIAMETER REEL

# Poke-Home: Single Vertical Contact

## 18-26 AWG: WTB

70-9296

70-9296-001-113-006

### 9296 VERTICAL MOUNT SMT CONTACT THROUGH BOARD CONTACT – TOP ENTRY WIRE (FR4 BOARD)

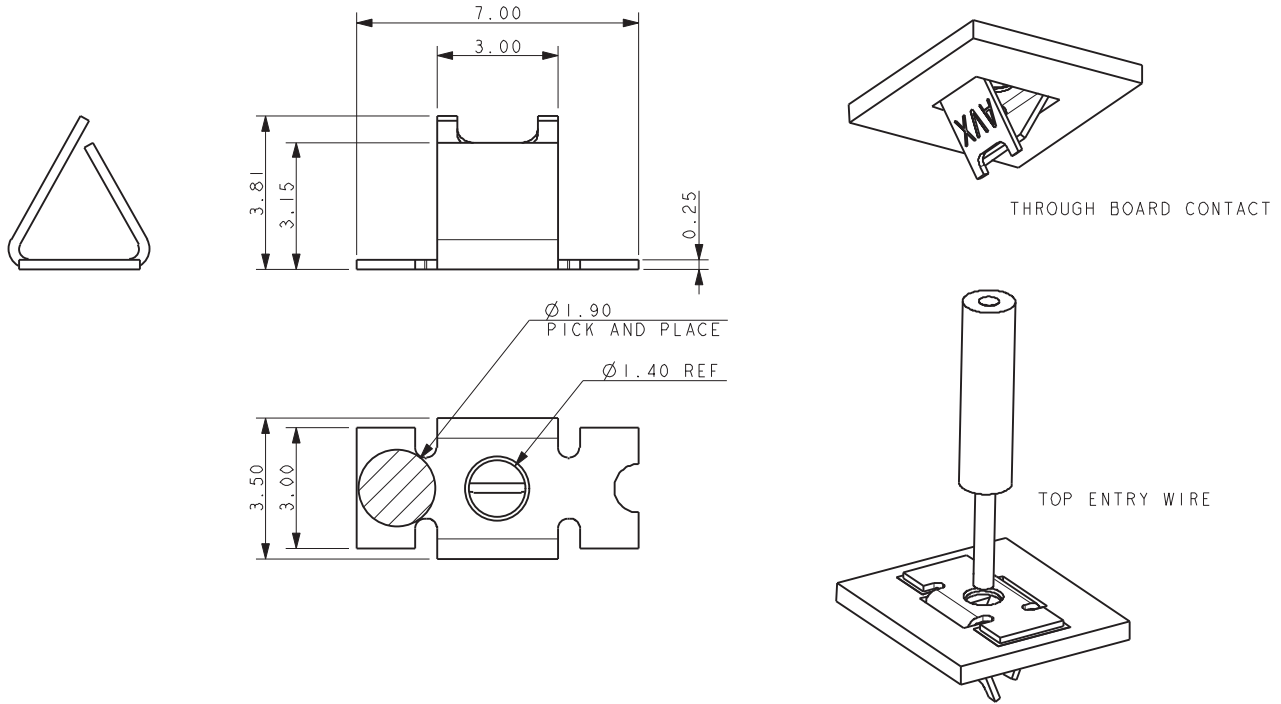

### SUGGESTED PCB LAYOUT

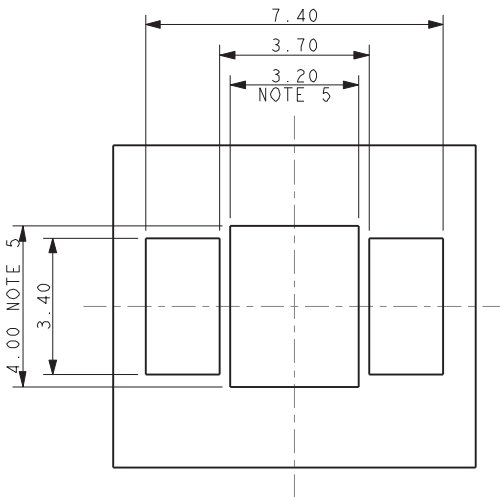

#### NOTES:

- CONTACT MOUNTS THROUGH THE BOARD, WIRE INSERTED FROM TOP SIDE OF BOARD.
- STYLE RECOMMENDED FOR FR4 BOARDS WHERE MINIMUM CLEARANCE REQUIRED TO CONTACT AND MOUNTING PADS.
- FOR FURTHER INFORMATION REFER TO ELCO SPECIFICATION 201-01-143 AND APPLICATION NOTES 201-01-150.
- MATERIAL: TIN PLATED PHOSPHOR BRONZE.
- HOLE DIMENSIONS FOR CONTACT.
- PACING IN TAPE AND REEL, 2000 PIECES PER REEL.
- FOR WIRE TRIM DETAILS REFER TO PAGE 96.

### PACKING DETAILS

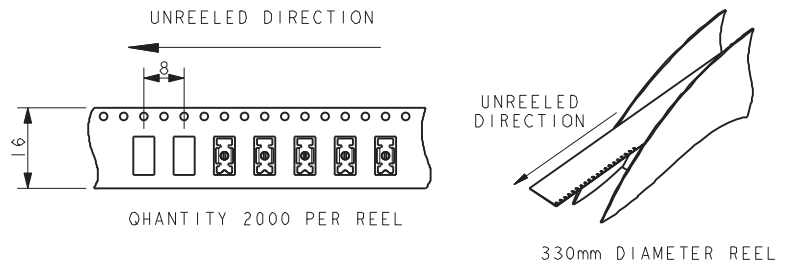

# Poke-Home: Single Vertical Contact

## 18-26 AWG: WTB

70-9296

70-9296-001-123-006

### 9296 VERTICAL MOUNT SMT CONTACT

#### TOP SIDE CONTACT – BOTTOM ENTRY WIRE (METAL BOARD)

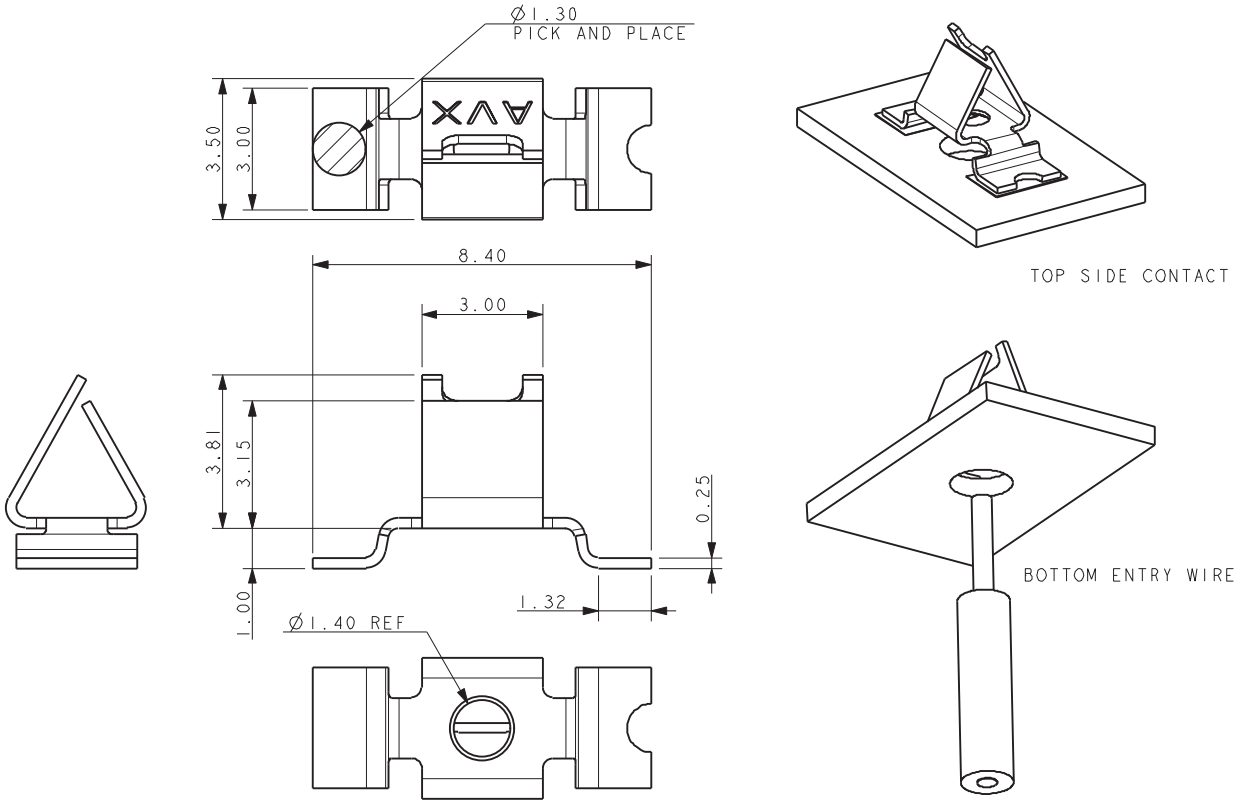

### SUGGESTED PCB LAYOUT

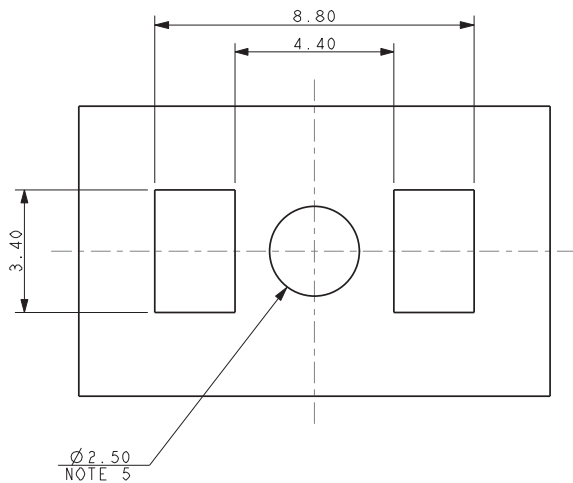

#### NOTES:

- CONTACT MOUNTS ON TOP SIDE OF BOARD, WIRE INSERTED FROM UNDERSIDE OF BOARD.
- STYLE RECOMMENDED FOR METAL CLAD BOARDS WHERE MAXIMUM CLEARANCE REQUIRED TO CONTACT AND MOUNTING PADS.
- FOR FURTHER INFORMATION REFER TO ELCO SPECIFICATION 201-01-143 AND APPLICATION NOTES 201-01-150.
- MATERIAL: TIN PLATED PHOSPHOR BRONZE.
- HOLE FOR WIRE INSERTION.
- PACING IN TAPE AND REEL, 1600 PIECES PER REEL.
- FOR WIRE TRIM DETAILS REFER TO PAGE 96.

### PACKING DETAILS

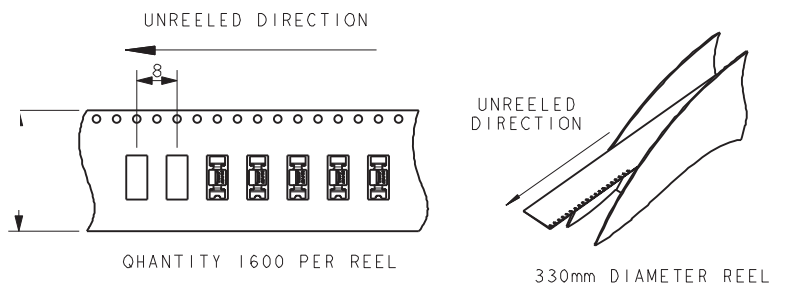

# Poke-Home: Single Vertical Contact

## 18-26 AWG: WTB

70-9296

70-9296-001-133-006

### 9296 VERTICAL MOUNT SMT CONTACT THROUGH BOARD CONTACT – TOP ENTRY WIRE (METAL BOARD)

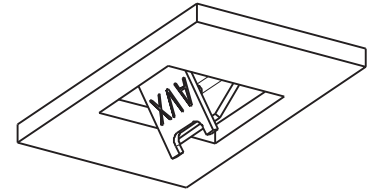
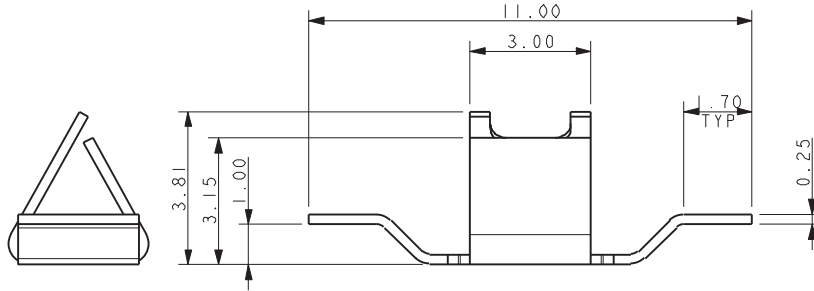

THROUGH BOARD CONTACT

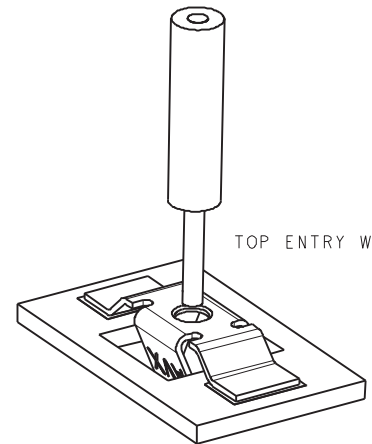
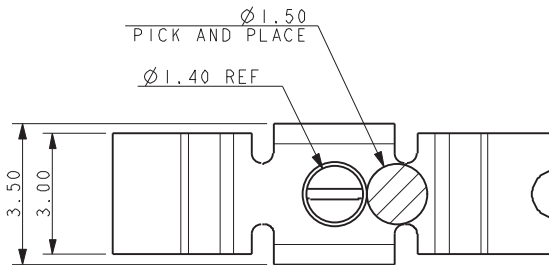

TOP ENTRY WIRE

### SUGGESTED PCB LAYOUT

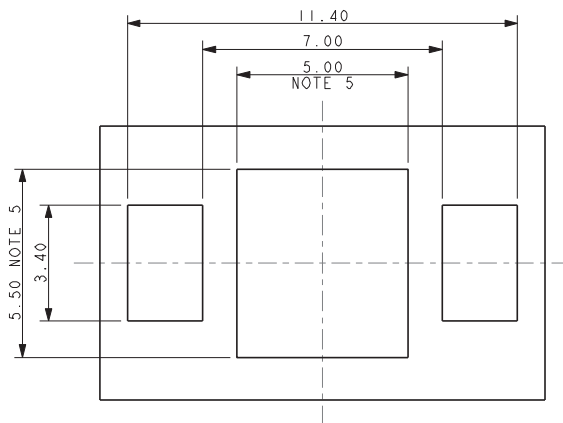

NOTES:

- CONTACT MOUNTS THROUGH THE BOARD, WIRE INSERTED FROM TOP SIDE OF BOARD.
- STYLE RECOMMENDED FOR METAL CLAD BOARDS WHERE ADDITIONAL CLEARANCE REQUIRED TO CONTACT AND MOUNTING PADS.
- FOR FURTHER INFORMATION REFER TO ELCO SPECIFICATION 201-01-143 AND APPLICATION NOTES 201-01-150.
- MATERIAL: TIN PLATED PHOSPHOR BRONZE.
- HOLE DIMENSIONS FOR CONTACT.
- PACING IN TAPE AND REEL, 2000 PIECES PER REEL.
- FOR WIRE TRIM DETAILS REFER TO PAGE 96.

### PACKING DETAILS

UNREELED DIRECTION

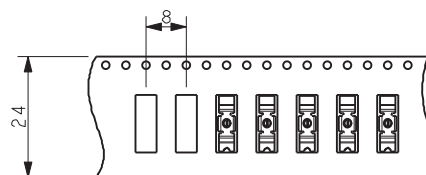

QUANTITY 2000 PER REEL

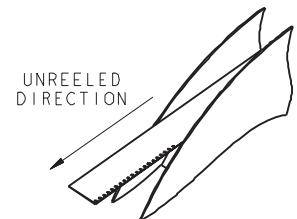

330mm DIAMETER REEL



# Poke-Home: Single Vertical Contact

## 18-26 AWG: WTB

70-9296

### 9296 VERTICAL MOUNT SMT CONTACT

#### WIRE TRIM DETAILS

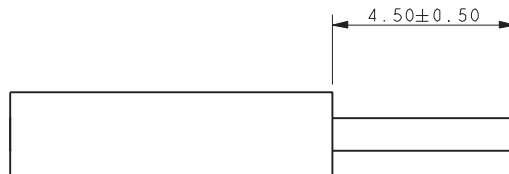

WIRE STRIP LENGTH, ALL STYLES

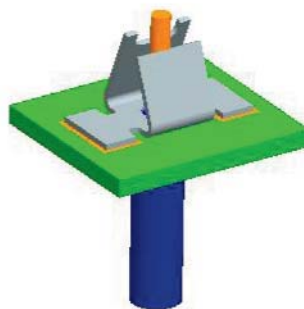

70-9296-001-103-006

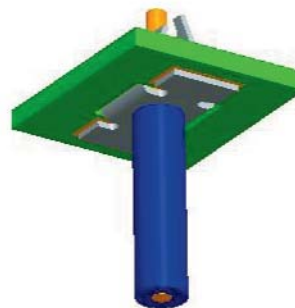

70-9296-001-113-006

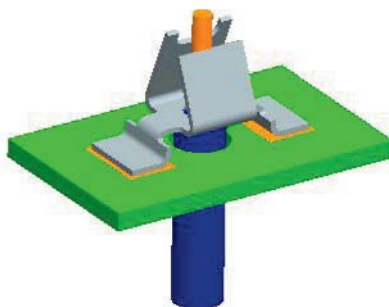

70-9296-001-123-006

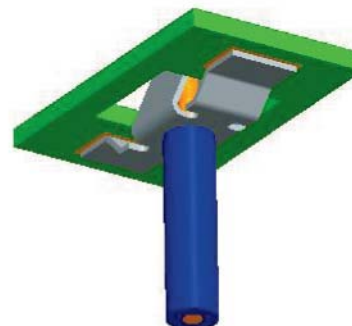

70-9296-001-133-006

NOTES:

1. FOR FULL ASSEMBLY PROCEDURE REFER TO APPLICATION NOTES 201-01-150.
2. THE SAME WIRE STRIP LENGTH APPLIES TO ALL STYLES.
3. STRANDED WIRES SHOULD BE TWISTED TO PREVENT SINGLE STRANDS BECOMING DETACHED WHEN INSERTED INTO CONTACT.

## AMERICAS

**AVX Greenville, SC**  
Tel: 864-967-2150

**AVX Northwest, WA**  
Tel: 360-699-8746

**AVX Midwest, IN**  
Tel: 317-861-9184

**AVX Mid/Pacific, CA**  
Tel: 408-988-4900

**AVX Northeast, MA**  
Tel: 617-479-0345

**AVX Southwest, CA**  
Tel: 949-859-9509

**AVX Canada**  
Tel: 905-238-3151

**AVX South America**  
Tel: +55-11-4688-1960

## EUROPE

**AVX Limited, England**  
Tel: +44-1252-770000

**AVX S.A.S., France**  
Tel: +33-1-69-18-46-00

**AVX GmbH, Germany**  
Tel: +49-0811-95949-0

**AVX SRL, Italy**  
Tel: +39-02-614-571

**AVX Czech Republic**  
Tel: +420-57-57-57-521

**AVX/ELCO UK**  
Tel: +44-1638-675000

**ELCO Europe GmbH**  
Tel: +49-2741-299-0

**AVX S.A., Spain**  
Tel: +34-91-63-97-197

**AVX Benelux**  
Tel: +31-187-489-337

## ASIA-PACIFIC

**AVX/Kyocera (S) Pte Ltd.,  
Singapore**  
Tel: +65-6286-7555

**AVX/Kyocera, Asia, Ltd.,  
Hong Kong**  
Tel: +852-2363-3303

**AVX/Kyocera Yuhan Hoesa,  
South Korea**  
Tel: +82-2785-6504

**AVX/Kyocera HK Ltd.,  
Taiwan**  
Tel: +886-2-2656-0258

**AVX/Kyocera (M) Sdn Bhd,  
Malaysia**  
Tel: +60-4228-1190

**AVX/Kyocera International  
Trading Co. Ltd.,  
Shanghai**  
Tel: +86-21-3255 1933

**AVX/Kyocera Asia Ltd.,  
Shenzen**  
Tel: +86-755-3336-0615

**AVX/Kyocera International  
Trading Co. Ltd.,  
Beijing**  
Tel: +86-10-6588-3528

**AVX/Kyocera India  
Liaison Office**  
Tel: +91-80-6450-0715

## ASIA-KED (KYOCERA Electronic Devices)

**KED Hong Kong Ltd.**  
Tel: +852-2305-1080/1223

**KED Hong Kong Ltd.  
Shenzen**  
Tel: +86-755-3398-9600

**KED Company Ltd.  
Shanghai**  
Tel: +86-21-3255-1833

**KED Hong Kong Ltd.  
Beijing**  
Tel: +86-10-5869-4655

**KED Taiwan Ltd.**  
Tel: +886-2-2950-0268

**KED Korea Yuhan Hoesa,  
South Korea**  
Tel: +82-2-783-3604/6126

**KED (S) Pte Ltd.  
Singapore**  
Tel: +65-6509-0328

**Kyocera Corporation  
Japan**  
Tel: +81-75-604-3449

### Contact:

