

# Hybrid Electric and Electric Cars

Electromobility driven by Semiconductor Innovations

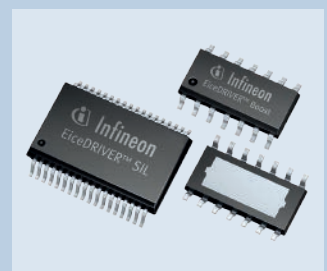

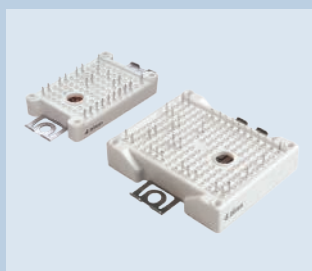
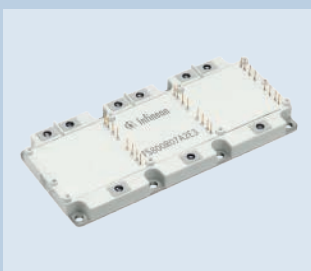

## Stepping up to the Energy Challenge

The need to conserve natural resources, reduce emissions and raise energy efficiency has become a major public concern. Amidst worries about dependence on oil and climate change, demand for electricity continues to soar. According to the International Energy Association, worldwide demand for electrical energy is set to rise by more than 60% over the next 20 years.

The way forward does not necessarily lie in producing more electricity, but in wasting less of it. To sustain our current economic model into the future, we need to optimize energy efficiency across the entire power chain, stretching from generation through distribution to actual consumption. In other words, industry is challenged to develop smart solutions enabling climate-neutral sourcing, intelligent distribution through smart grids and efficiency-aware applications and appliances.

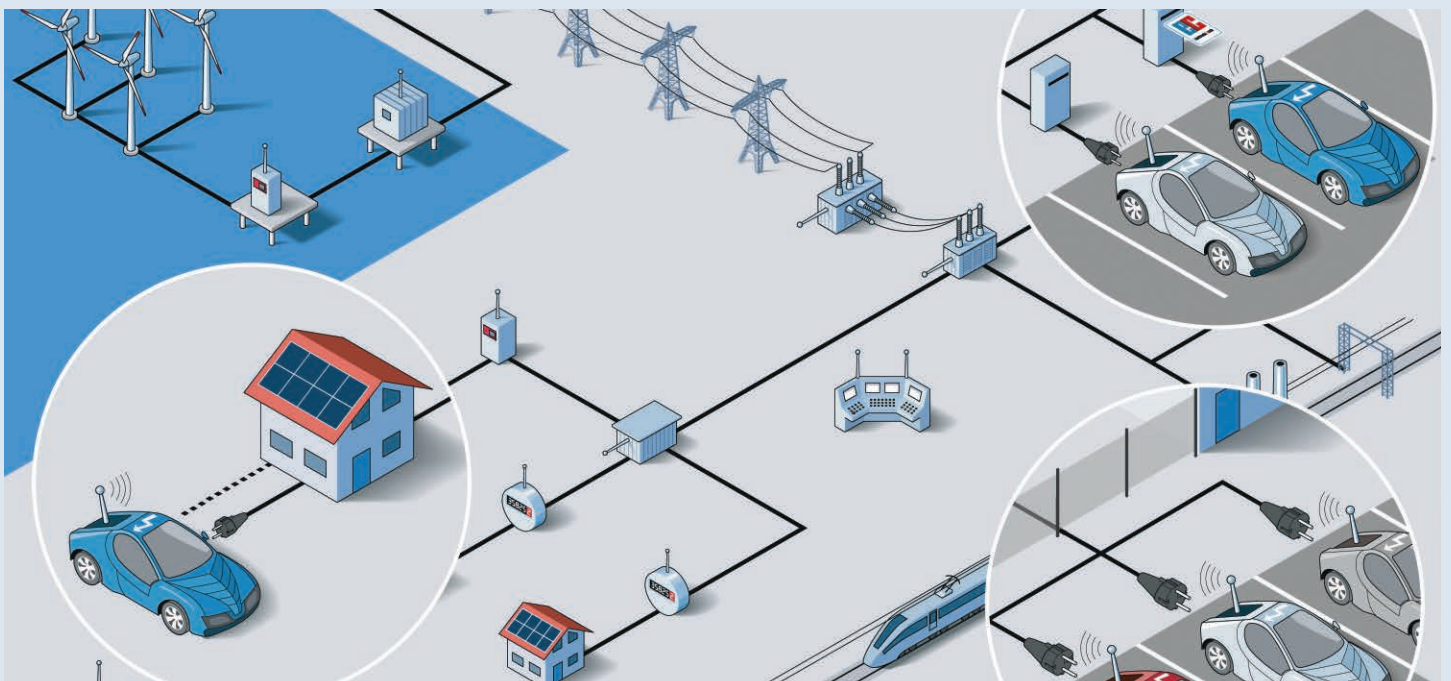



## Spotlight on Personal Mobility

Personal mobility is a big contributor to CO<sub>2</sub> emissions. Consequently, a current focus on energy efficiency is placing the spotlight on cars. The growing number of cars on our roads each year is forcing industry players and policy-makers to explore alternative forms of mobility with a smaller CO<sub>2</sub> footprint.

One extremely effective way of reducing carbon emissions involves electrifying the drivetrain of cars. The advantages of Electric Vehicles (EV) include higher energy efficiency of the drivetrain, lower noise levels and zero tailpipe emissions when powered solely by the battery.

In order for EVs to be truly viable, however, various challenges must be overcome. These include the high initial cost of the battery and the lower driving range. Widespread acceptance also hinges on a standardized infrastructure for recharging with uniform connectors and charging voltages, for instance. And – most importantly – intelligent energy concepts are key to achieving environmental goals. EVs must be part of a smart electricity grid which relies on Information Technology (IT) to increase efficiency, reliability and interoperability.

## Semiconductors Key Enablers in “Going Smart”

Semiconductors play a key role in building more intelligence into the energy cycle. Underpinned by our sense of environmental responsibility and strategic focus on energy efficiency, mobility and security, we are already delivering the semiconductor innovations required to resolve these challenges and design intelligent power networks,

accelerating the paradigm shift towards electromobility on the road. When it comes to building tomorrow’s electric infrastructure, our semiconductor solutions will form the backbone of the enabling smart grid, allowing drivers to recharge intelligently, pay securely and feed power back into the electricity grid.



## Moving Forward

The transition to a new age of mobility will be a gradual one. As we move beyond the Carbon Age and our dependence on fossil fuels, Hybrid Electric Vehicles (HEV) will play an important role alongside lower-carbon combustion engines during the transitional period. Although electric drivetrains are already more energy-efficient than combustion models, further improvements are still required.

Vehicles combining an electric drive with a compact battery and complementary internal combustion engine basically will pave the way for all-Electric Vehicles (EV). Drivetrain electrification calls for high-power semiconductors designed to automotive quality standards. Expertise in both power semiconductors and automotive electronics is thus essential to successfully serve the emerging HEV and EV market.

### Hybrid- and Electric Vehicles

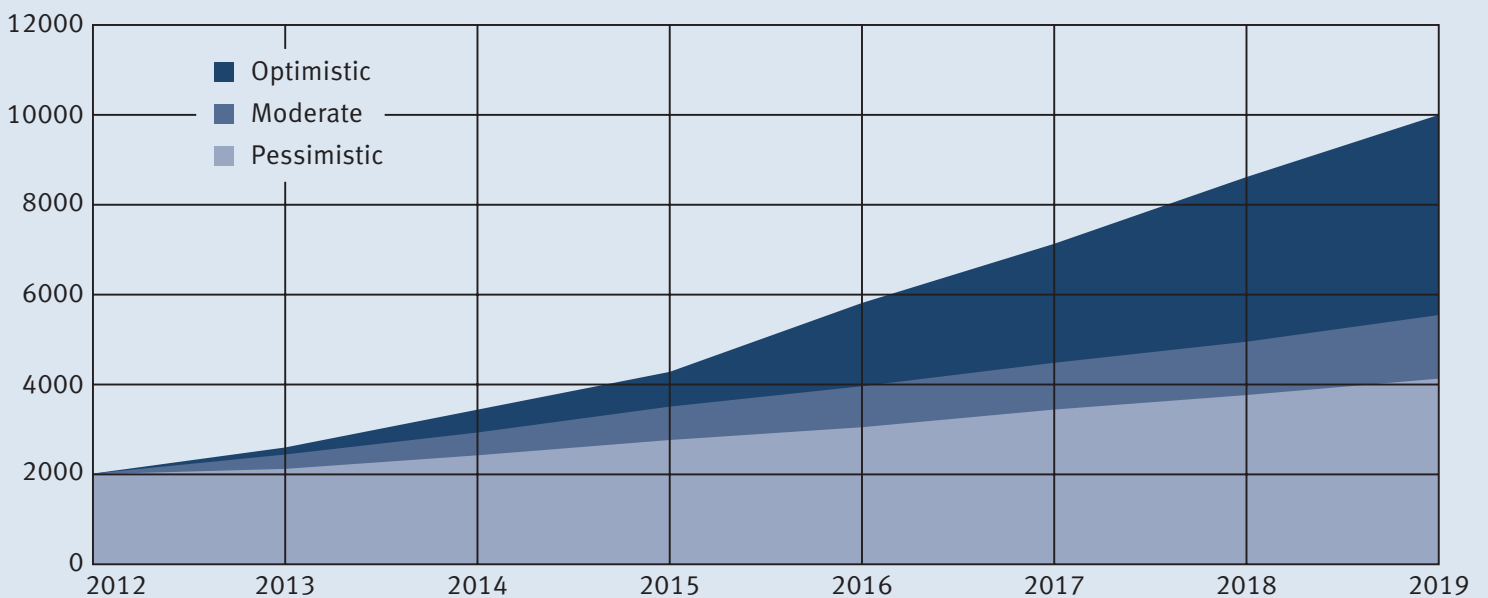

Although the combustion engine still dominates today's drive train technologies, electrification is emerging as an increasingly strong force in tomorrow's green mobility landscape.



## Experience Pays

---

As world leader in advanced power and automotive electronics, we are the only player worldwide who combines both areas of expertise – bundling forty years' experience in automotive electronics and high-power electronics with ten years' experience in electromobility. A leading supplier of high-power IGBT modules for drive and traction applications for many decades now, we supplied the IGBT modules that powered the TGV to a new world speed record in 2007, for example.

We now have the broadest (H)EV range of power modules and chips dedicated to optimizing overall system cost, minimizing power losses, increasing power density, maximizing power savings, extending mileage and improving battery efficiency. Car makers and system suppliers all over the world already rely on products from Infineon Technologies to drive new innovations.

This bundled experience makes us the ideal partner to drive the trend towards electric cars and benefit from this growing market. Here we project strong revenue growth as the powertrain semiconductor bill-of-materials for an EV/HEV is a multiple higher than the corresponding bill for a combustion engine.

Our strong commitment to driving efficiency and cost-effectiveness in the industry is reflected in active involvement in a variety of research projects. For instance, we initiated the E3Car (Energy Efficient Electrical Car) European research project. 30 European companies and academic institutes are working together to develop electronic innovations aimed at raising the efficiency bar by 35%.



## Leading Innovative Semiconductor Solutions for HEVs/EVs

---

In an electric vehicle, the combustion engine is replaced by an electric motor while in a Hybrid Electrical Vehicle (HEV), the combustion engine is supplemented with an electric motor. Semiconductors are indispensable for all types of electrified powertrains. Regardless of the model, bundled high-power and automotive system expertise is essential to serve this market successfully.

As the world leader in advanced power electronics and the world leader in automotive electronics, our know-how and system expertise puts us in a perfect position to provide innovative, high-performance semiconductor solutions with best-in-class technologies for hybrid and electric vehicles.

Drawing on our long-standing experience in the development of leading IGBT power modules and high-efficiency technologies for the industrial market, we have developed dedicated, automotive-qualified high-power modules for highest power

densities and efficiency. Our broad product portfolio enables a smooth transition across all power classes from mild HEV to high-power EV. Suitable for all electric drivetrain architectures, our offering comprises discrete components, power semiconductors, microcontrollers, sensors and high-power modules.

Thanks to our system expertise, we are able to provide complete chipsets offering optimized performance and reduced overall system costs. Our semiconductor solutions for (H)EV are proof of the exceptional quality and reliability that the world's leading automotive manufacturers have come to know and expect from Infineon. And we are proud to be able to deliver market-leading (H)EV solutions already today. By offering innovative and highly efficient products of outstanding quality, we are driving innovative electrified powertrain solutions geared towards more sustainable mobility choices.

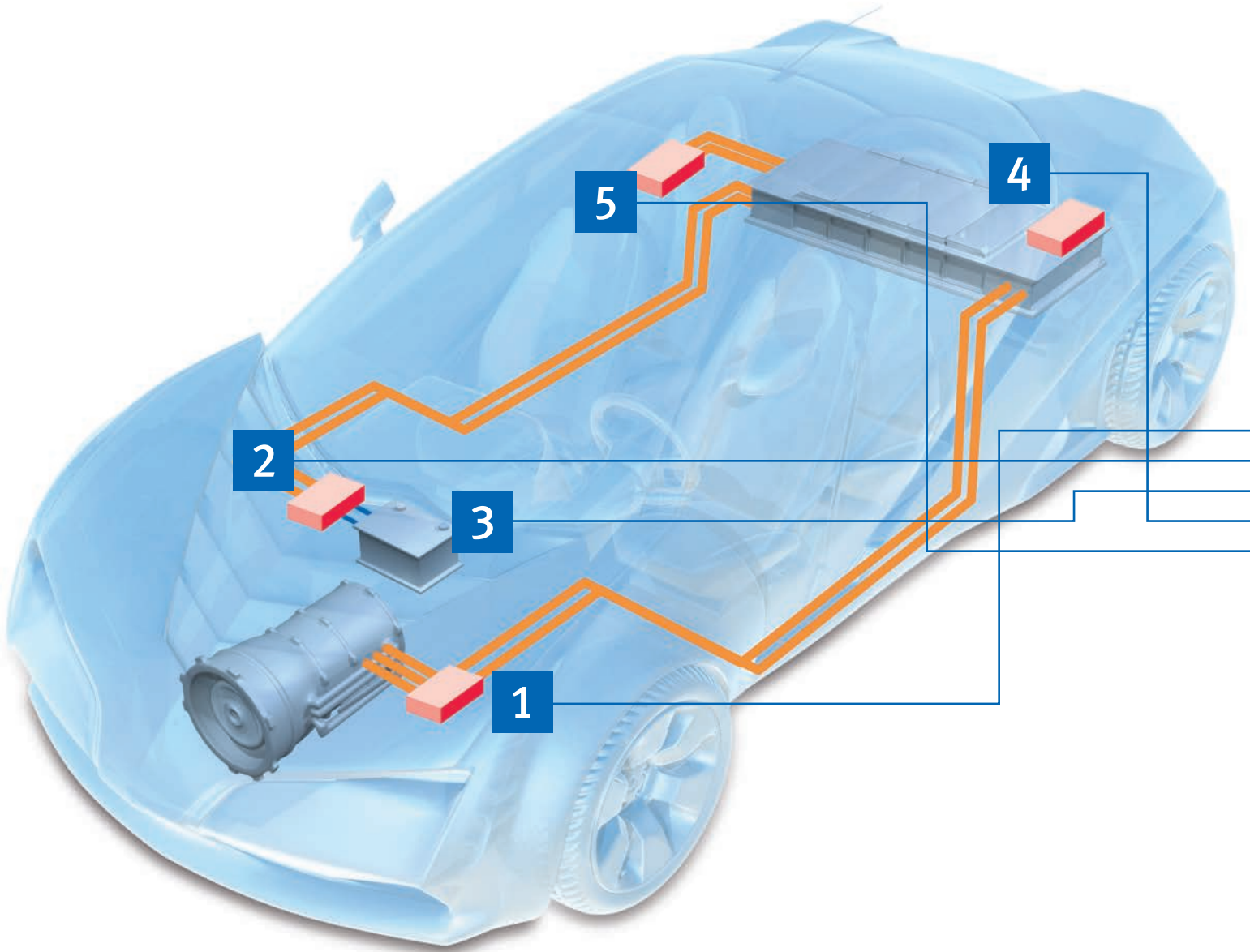

# Application Overview

## 1 Main Inverter

The inverter not only drives the electric motor, but is also used for regenerative braking and feeding energy back to the battery.

## 2 DC/DC Converter

The DC/DC converter charges the conventional 12V power supply net from the high-voltage battery and replaces the former belt driven alternator.

## 3 Auxiliary Inverters/Converters

Instead of being belt-driven, auxiliaries like water pump, HVAC Compressor, PTC Heater, etc. also have to be driven by electric power. Inverters are needed to drive them smart and energy-efficient.

## 4 Battery Management

The battery management system controls battery state during charging and discharging. Intelligent functionality is needed to extend the battery lifetime, which has a considerable impact on the total cost of ownership. The State of Health (SoH), State of Charge (SoC) and Depth of Discharge (DoD) of the battery is permanently monitored.

## 5 On-board Charger

The battery block is charged via an AC/DC converter module. In the example shown here, an on-board unit charges the battery. Off-board and inductive charging solutions are also available.



## Worldwide leading

Power Electronics

Automotive Electronics

Experienced  
application support

Dedicated EV/HEV  
components for highest power  
density and efficiency

Comprehensive quality  
management program

Broadest product portfolio  
for high-efficiency EVs/HEVs

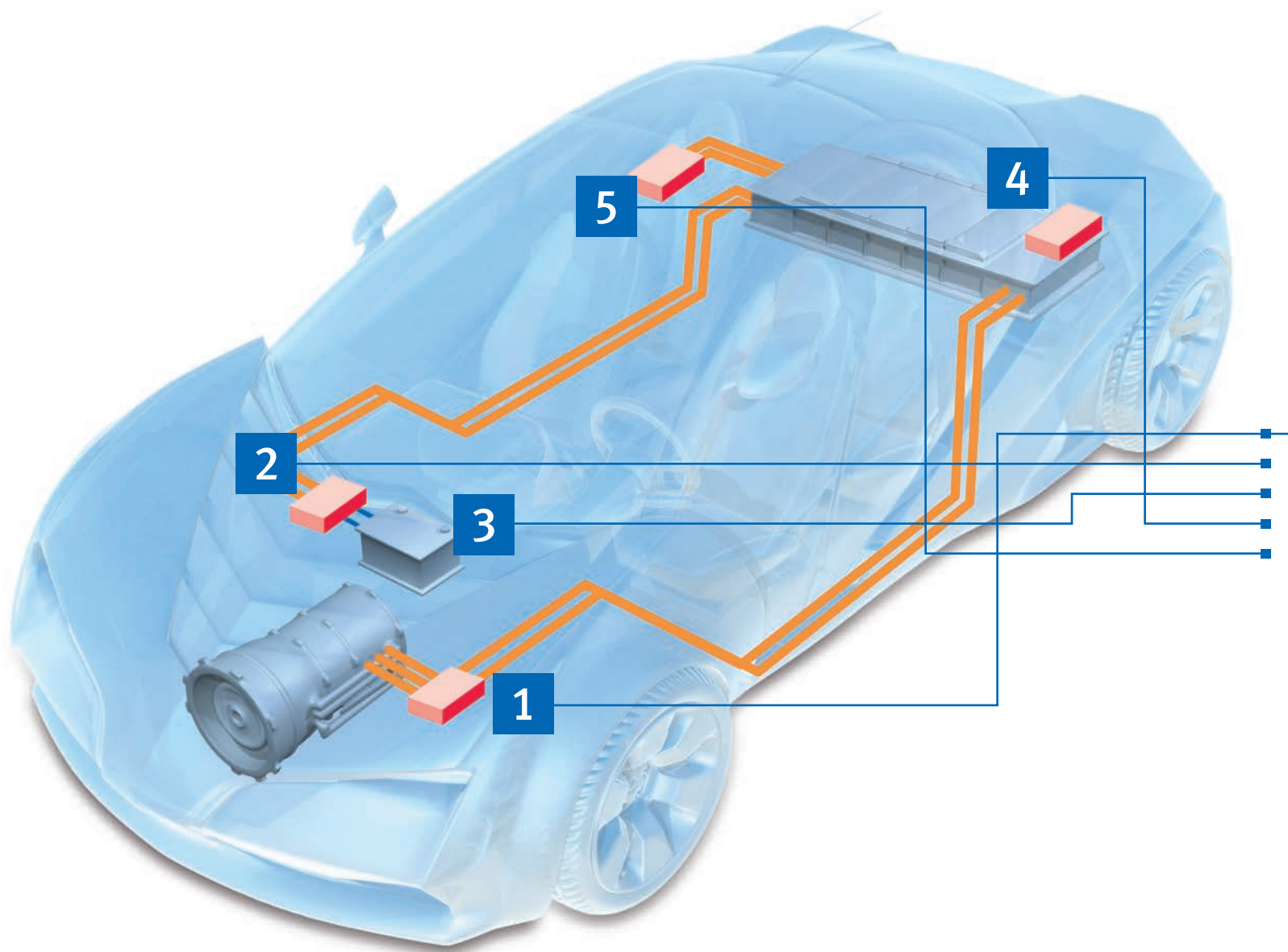



# 1 Main Inverter

With an electric drivetrain, the inverter controls the electric motor. This is a key component in the car as, similar to the Engine Management System (EMS) of combustion vehicles, it determines driving behavior. Regardless of whether the motor is synchronous, asynchronous or brushless DC, the inverter always functions in a similar way and is controlled by an integrated PCB, which should be designed to minimize switching losses and maximize thermal efficiency. Not only does the inverter drive the electric motor, it also captures energy released through regenerative braking and feeds this back to the battery. As a result, the range of the vehicle is directly related to the efficiency of the main inverter.

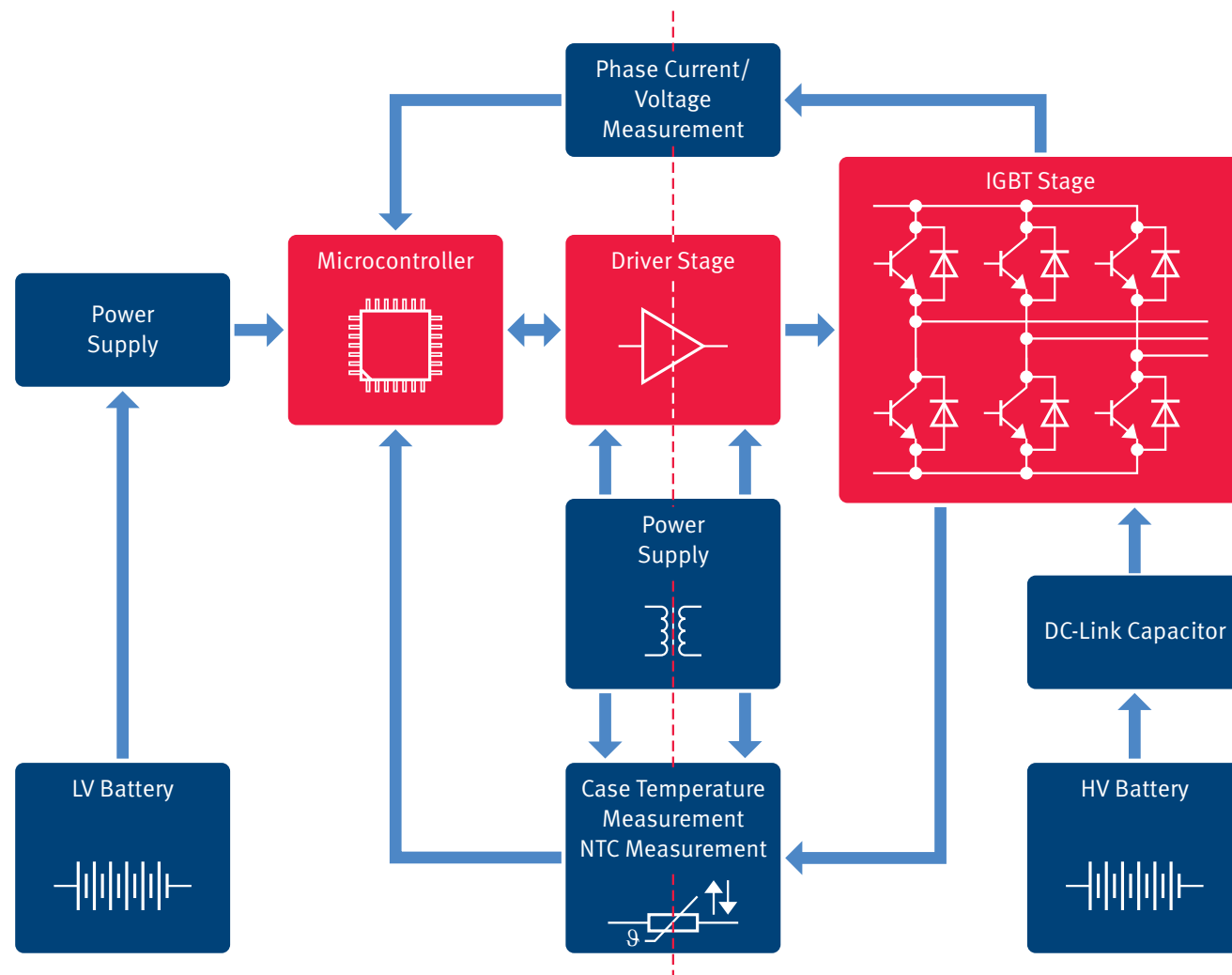

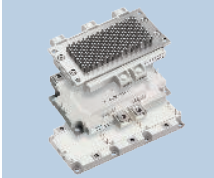

## Our semiconductor solutions for the main inverter

Our highly reliable semiconductor solutions support a wide range of motors, generators and power classes, enabling compact and cost-efficient system designs offering high energy efficiency thanks to the reduction of power losses. Highlights include:

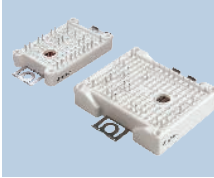
- 

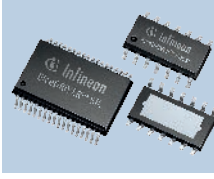
Our HybridPACK™ family enables a smooth transition across all power classes from HEV to EV (from 10kW to 100kW). These integrated power modules contain all power semiconductors required to drive electric motors of up to 100kW, with the added bonus of compact inverter designs and optimum support for water cooling.
- 

Easy Family  
Our Easy automotive power modules enable compact designs and the highest energy efficiency ratings for auxiliary drives and converters.
- 

EiceDRIVER™ is a family of gate driver ICs with the perfect feature set to drive and control the IGBTs. The EiceDRIVER™ family includes single and dual channel automotive IGBT Driver IC's providing galvanic isolation and bidirectional signal transmission.
- 

Our wide range of high-performance 32-bit microcontrollers dedicated to (H)EV solutions are the perfect complement to our product portfolio for energy-efficient electric drivetrains.
- 

Our position sensors enable closed-loop feedback of motor position for Field-Oriented Control (FOC).

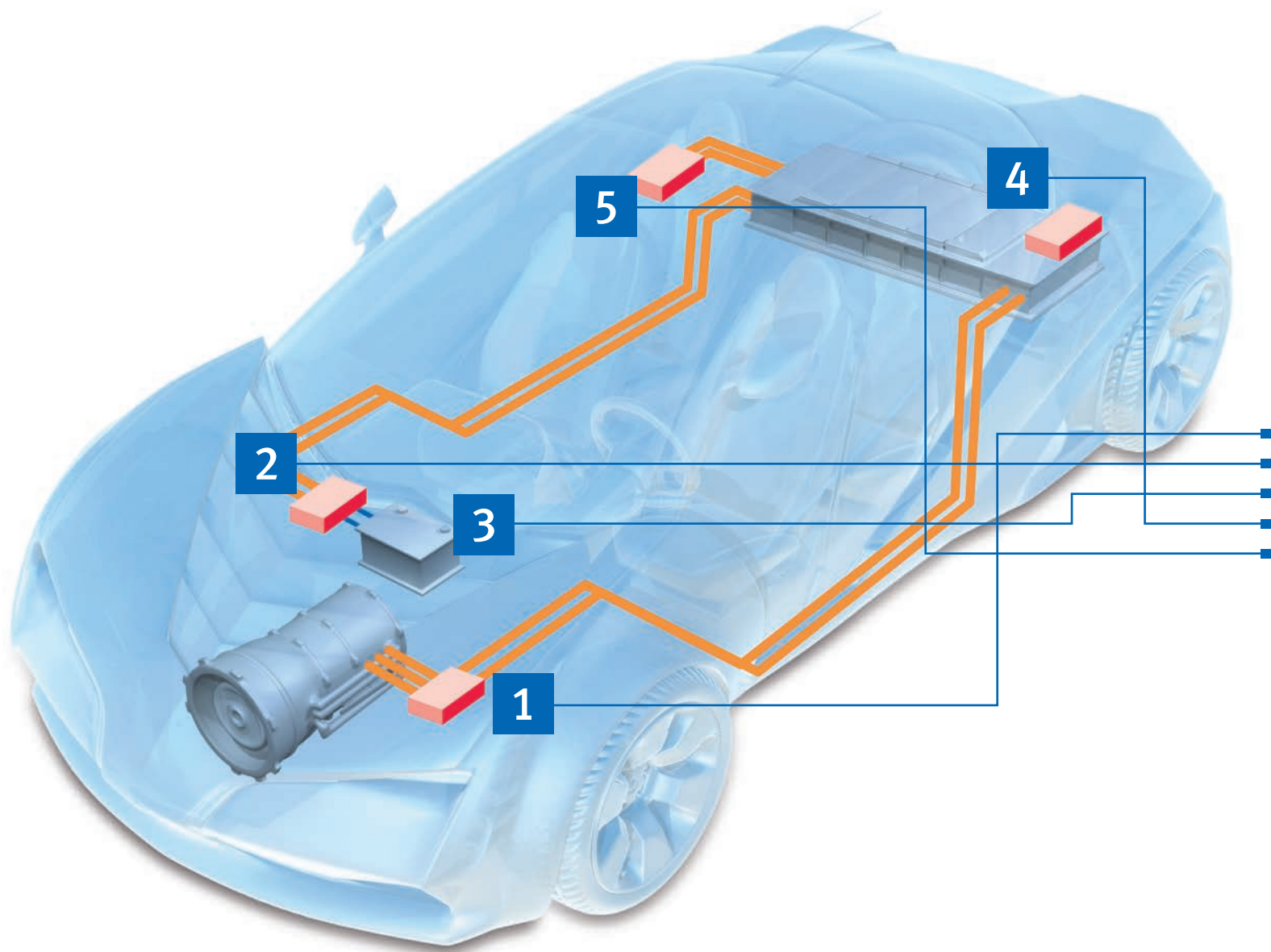

## 2 DC/DC Converter

Different voltage levels are required by the various electronic components in an EV. High-voltage batteries with different voltage levels are currently available on the market. In addition, the power classes scale from 1kW to 5kW depending on the number of low-voltage applications. In the past, the alternator was used to supply the 12V power supply system. In EVs and HEVs, the DC/DC converter supplies the 12V power system from the high-voltage battery. Designers are called on to increase conversion efficiency as a way of extending the range of the vehicle. In addition, different components may be required depending on whether the design is suited for uni- or bidirectional energy transfer.

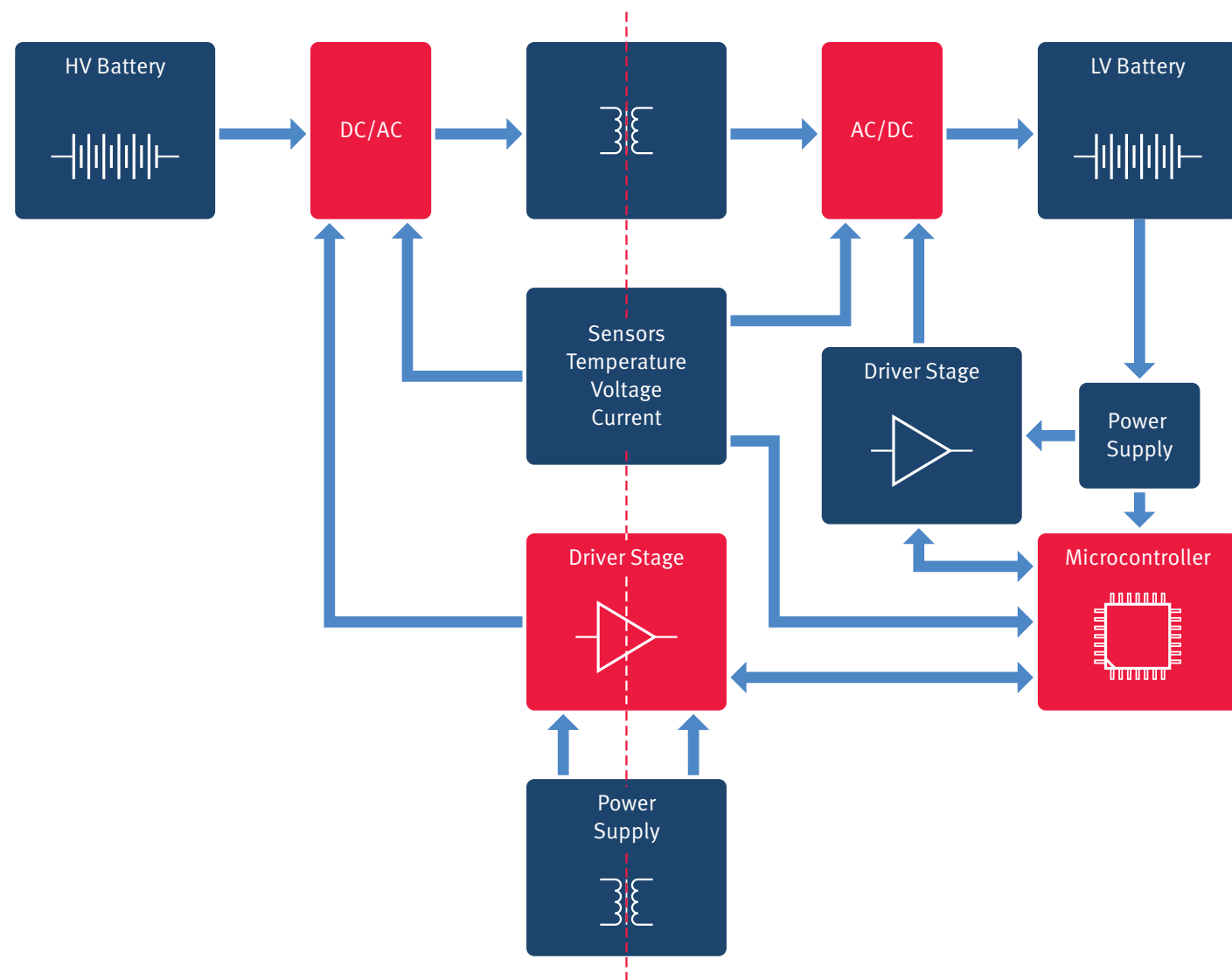

### Our semiconductor solutions for the DC/DC converter

Our chip solutions enable designers to build small DC/DC converters with high power density supporting all voltage and power classes. Highlights include:

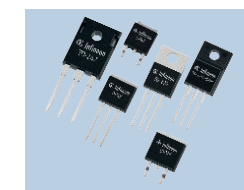

CoolMOS™ transistors for high-voltage side – this MOSFET is based on our super junction technology, ensuring low  $R_{DS(on)}$  at high switching frequencies.

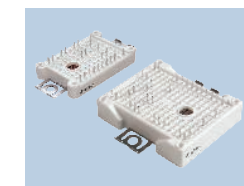

Our Easy automotive power modules with high speed IGBT3 and Rapid Diode enable a compact design and the highest energy efficiency ratings for converters from about 2–10kW.

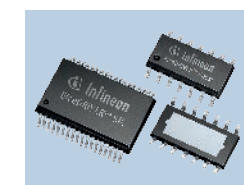

EiceDRIVER™ is a family of gate driver ICs with the perfect feature set to drive and control IGBTs. These isolation-integrated gate driver ICs significantly reduce space requirements on the control board.

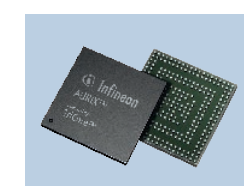

Our wide range of high-performance 32-bit microcontrollers dedicated to (H)EV solutions are the perfect complement to our product portfolio for energy-efficient electric drivetrains.

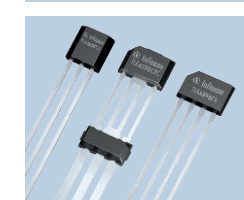

The Linear Hall IC family TLE4998 is optimized for measuring high currents with different digital output.

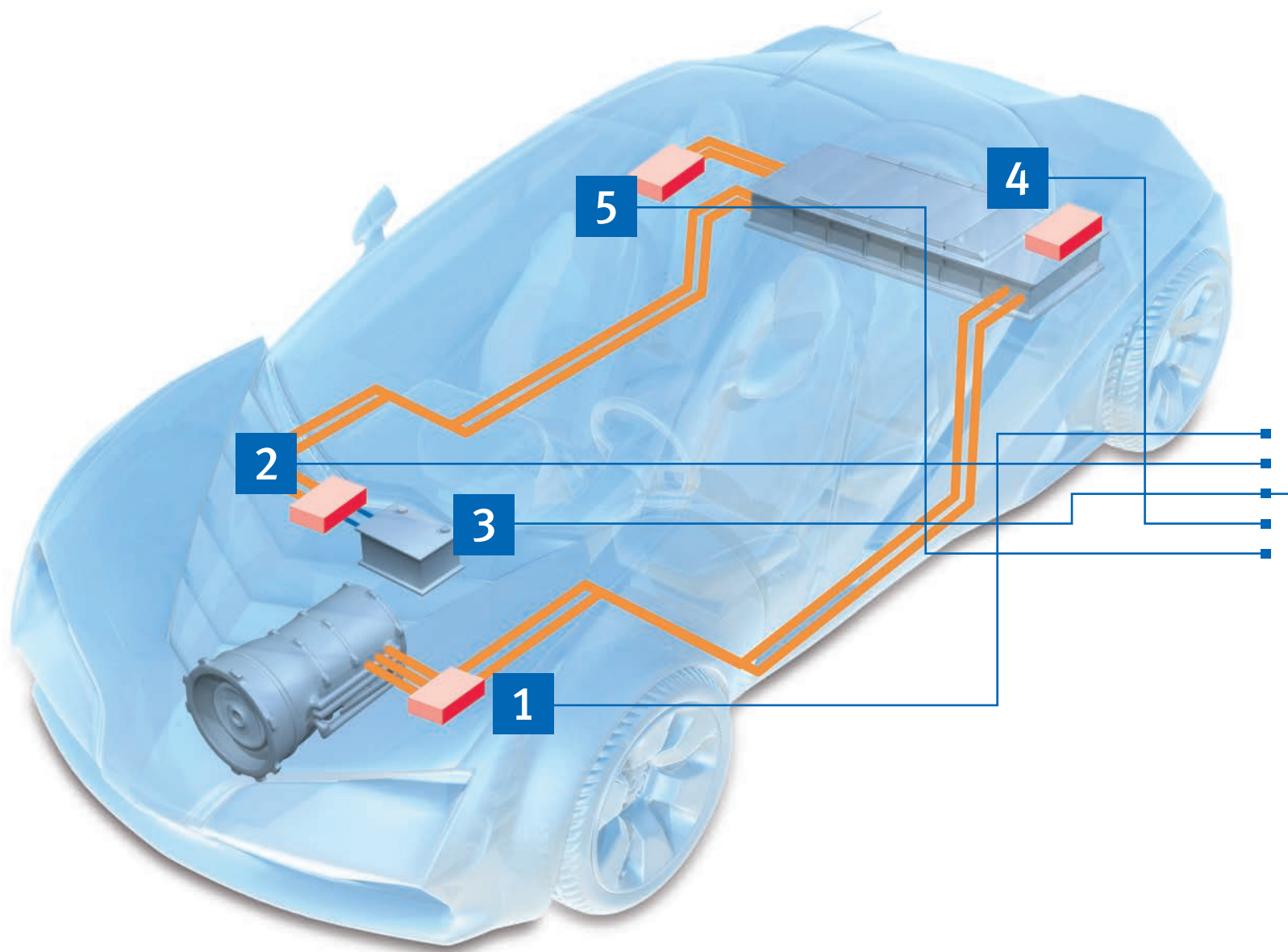

### 3 Auxiliary Inverters/Converters

Power on demand increases the efficiency of electric vehicles. With HEVs and EVs, former belt-driven devices classified as auxiliary drives have been electrified and integrated into the power system to deliver power on demand. Typical auxiliary systems supplied from the high-voltage battery include air conditioning, electronic power steering, PTC Heater, oil pumps and cooling pumps. As power from the battery is expensive, the challenge is to use the electric power as efficiently as possible. Designers are thus looking to optimize the power efficiency of all auxiliary systems.

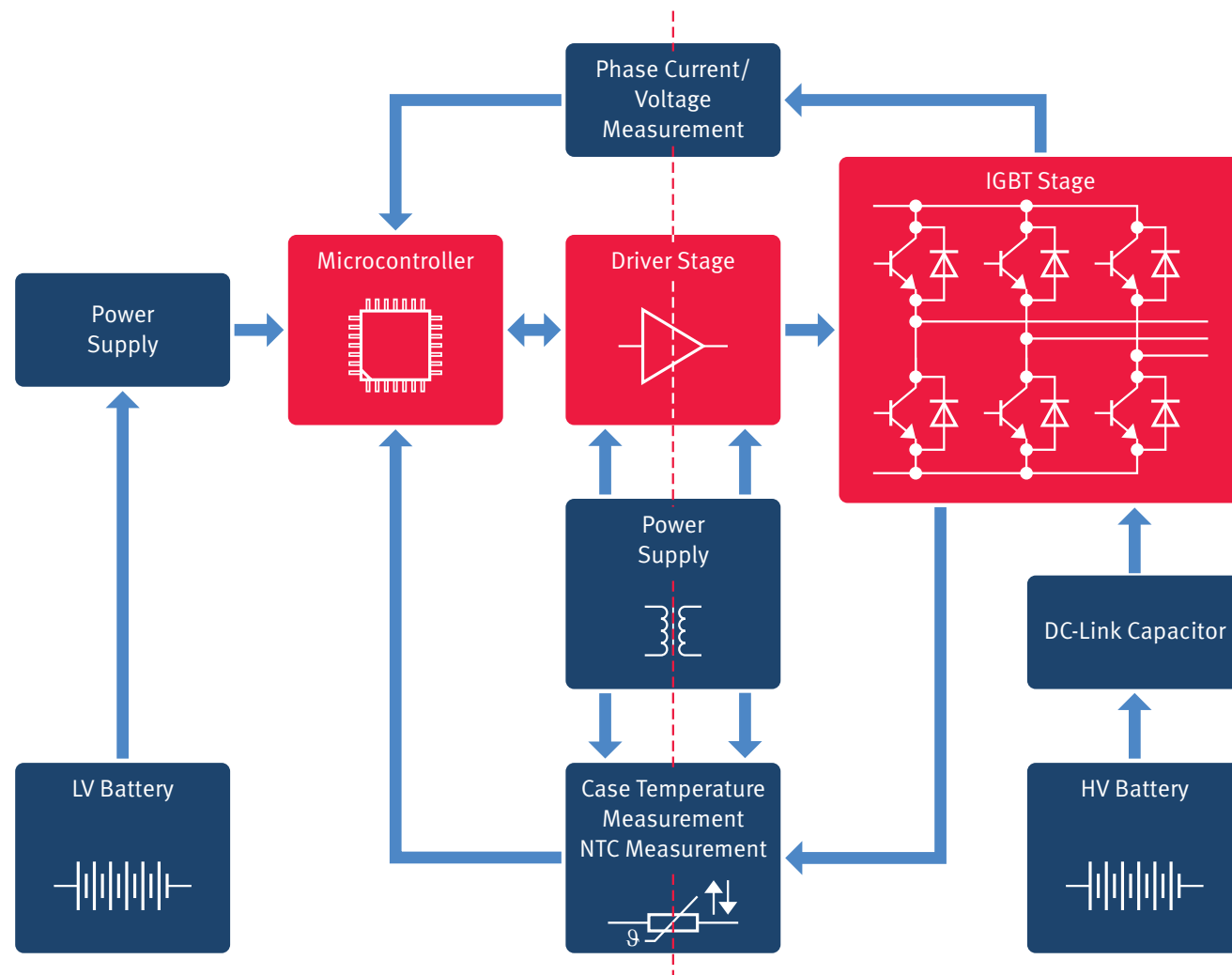

#### Our semiconductor solutions for the auxiliary inverter

Our fully automotive-qualified product portfolio supports a wide range of motors, generators and power classes and enables compact designs offering high power density. Highlights include:

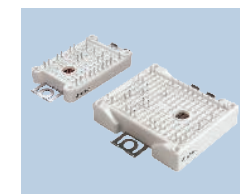

Our Easy automotive power modules enable compact designs and the highest energy efficiency ratings for auxiliary drives and converters.

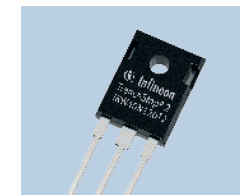

High-efficiency, low-loss IGBT discrettes bundle our outstanding trench and fieldstop technologies to reduce saturation voltages well below the levels offered by competing standard NPT IGBTs – without increasing switching losses.

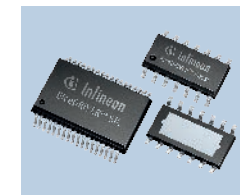

EiceDRIVER™ is a family of gate driver ICs with the perfect feature set to drive and control IGBTs. These isolation-integrated gate driver ICs significantly reduce space requirements on the control board.

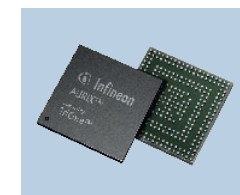

Our wide range of high-performance 32-bit microcontrollers dedicated to (H)EV solutions are the perfect complement to our product portfolio for energy-efficient electric drivetrains.

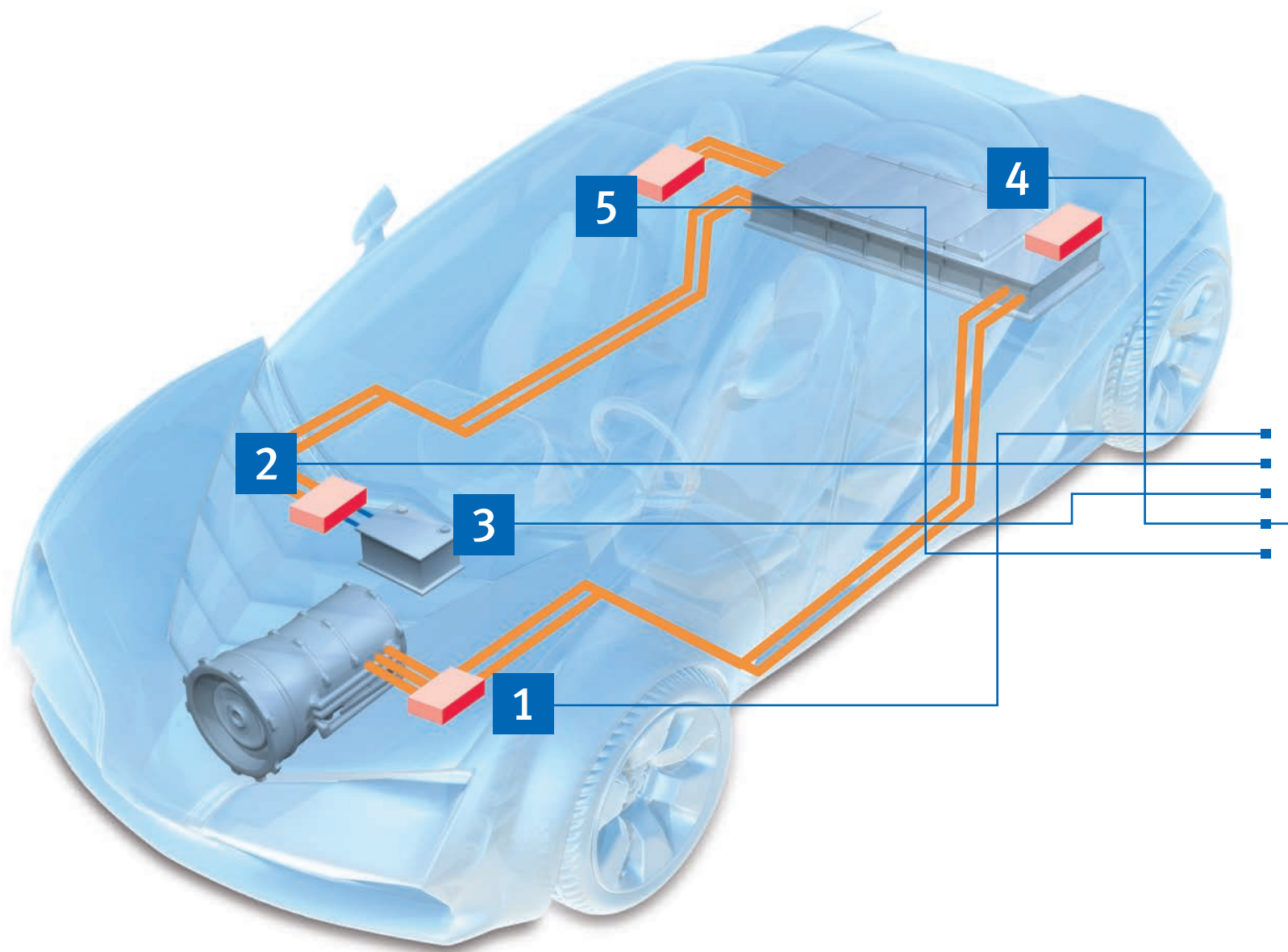

## 4 Battery Management

The battery management system controls battery state during charging and discharging. Intelligent functionality is needed to extend the battery lifetime, which has a considerable impact on the total cost of ownership. The State of Health (SoH), State of Charge (SoC) and Depth of Discharge (DoD) of the battery is permanently monitored. As battery cells age, the capacity of individual cells is changing and variation to nominal capacity is increasing. The challenge is to optimize cell usage. A cell supervision circuitry enables active or passive cell balancing during charging and discharging.

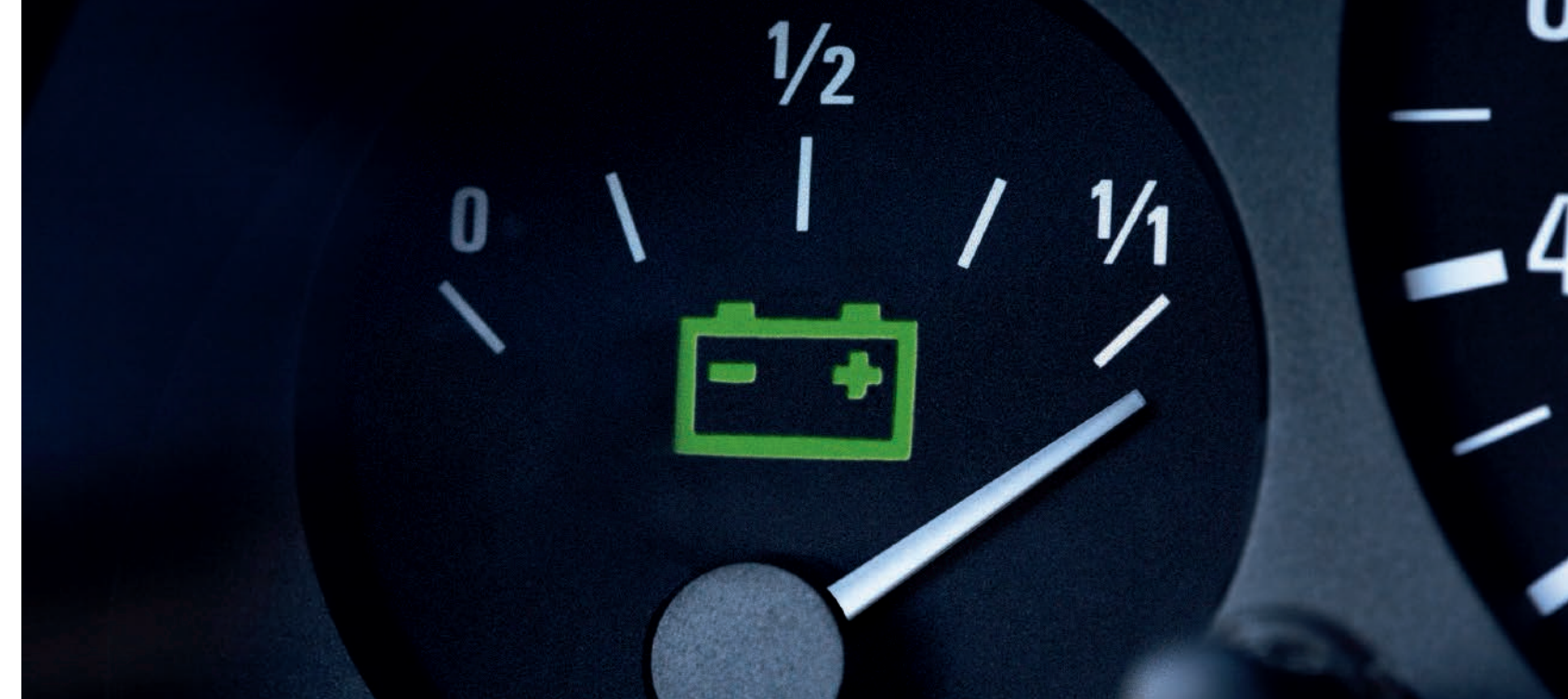
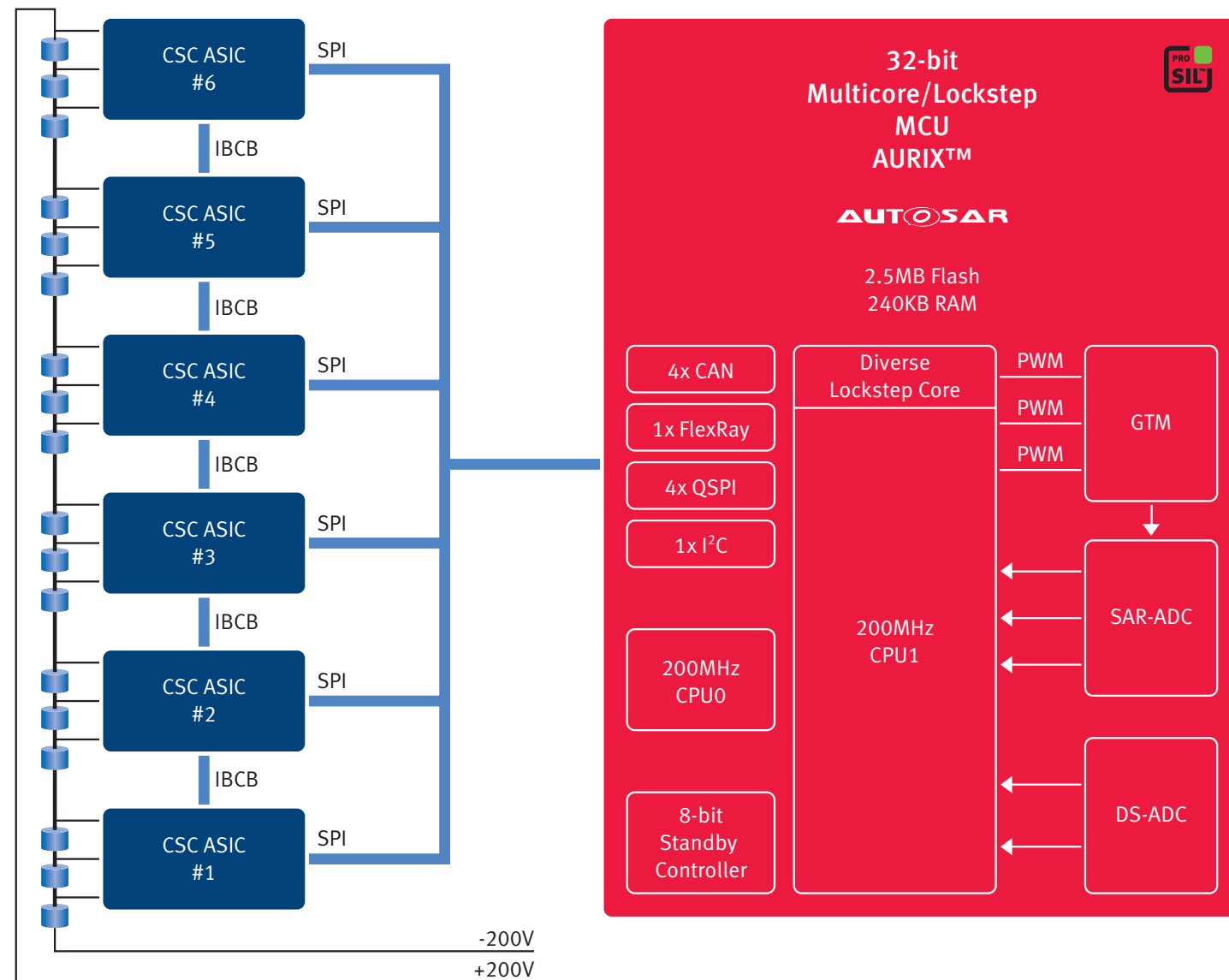

### Our semiconductor solutions for battery management

A broad portfolio of microcontrollers and sensors to monitor State of Charge (SoC), State of Health (SoH) and Depth of Discharge (DoD) for the longest possible battery lifetime.

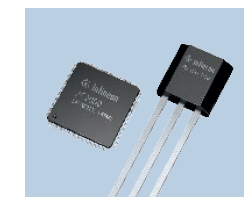

We offer a broad portfolio of microcontrollers and sensors to monitor State of Charge (SoC), State of Health (SoH) and Depth of Discharge (DoD) for the longest possible battery lifetime.

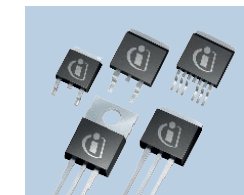

With OptiMOS™, we offer the latest automotive MOSFET products offering superior performance based on our market-leading MOSFET technology, excellent quality and robust packages. The OptiMOS™ family is designed for low  $R_{DS(on)}$  at high switching frequencies.

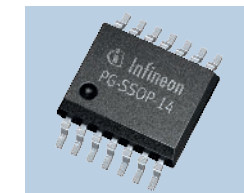

In addition, we offer an extensive complementary range of CAN transceivers featuring the best combined ESD and EMC performance on the market. We also have a comprehensive portfolio of linear voltage regulators offering highest quality and robust design for long-term reliability

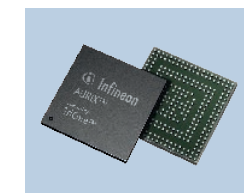

Our wide range of high-performance 32-bit microcontrollers dedicated to (H)EV solutions are the perfect complement to our product portfolio for energy-efficient electric drivetrains.

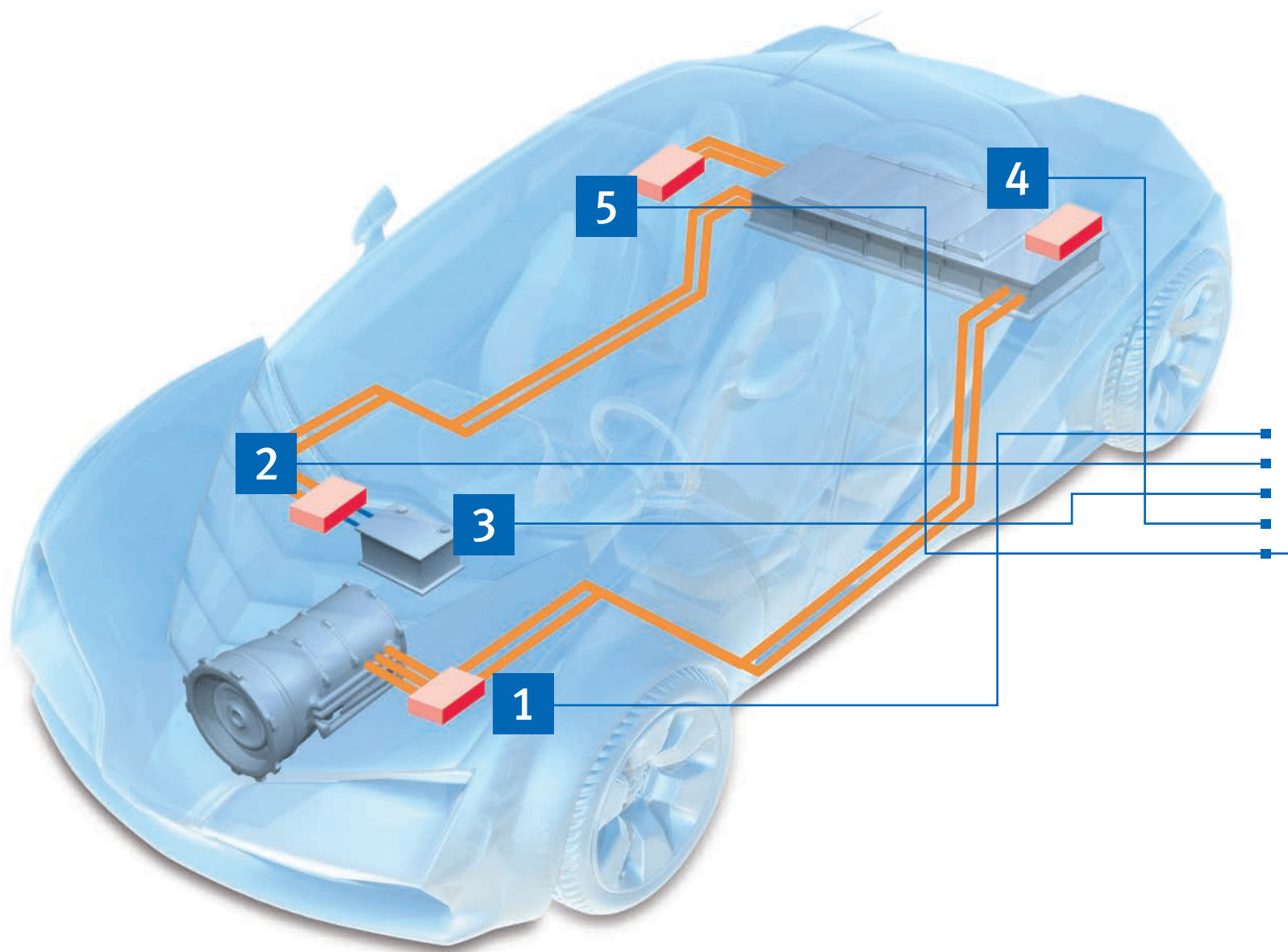



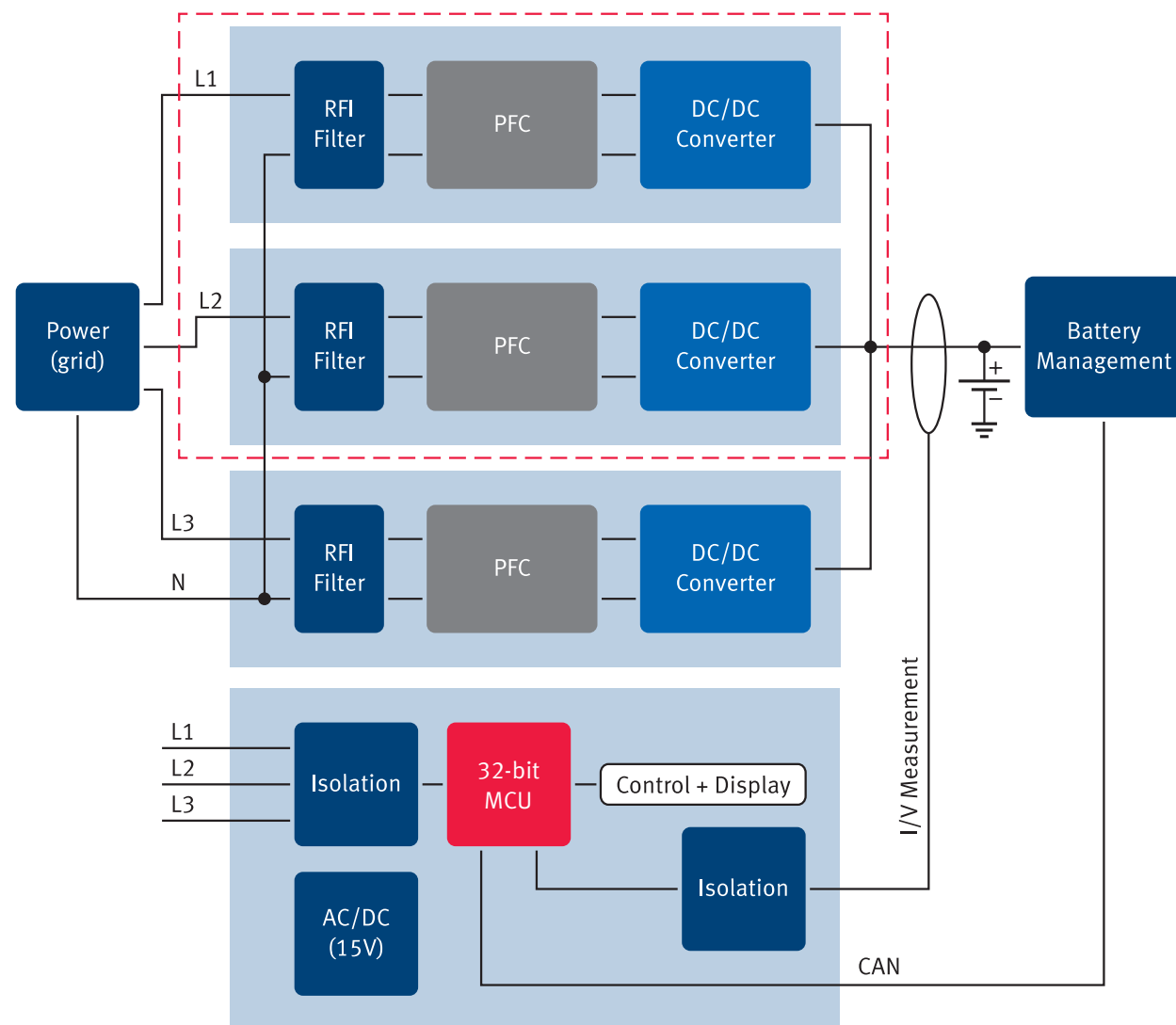

## 5 On-board Charger

The battery in an electric vehicle is useless without a battery charger. And all electronic systems depend on the battery for power. With an on-board charger unit, the battery can be charged from a standard power outlet. Charging via the main grid calls for design flexibility given the different voltage and current levels in different countries. And charging time is an important factor for car drivers. System designers are challenged to support varied voltage and current levels while increasing power density. The key success factors of on-board charging are efficiency and high power density for a small form factor. The long-term trend is moving towards bi-directionality, where the charger also feeds power from the car to the smart grid.

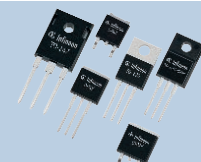

### Our semiconductor solutions for the on-board chargers

Our comprehensive product portfolio provides the perfect fit for compact charger units ( $>> 10\text{kW}/\text{dm}^3$ ) designed for high switching frequencies, lower weight and adjustable displacement power factors. Our isolated gate drivers ensure safe operation. Highlights include:

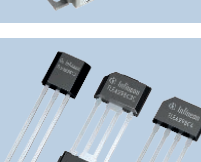
- 
 Our wide range of high-performance 32-bit microcontrollers dedicated to (H)EV solutions.
- 
 CoolMOS™ transistors – High-voltage automotive MOSFETs for low-power charging solutions (overnight).
- 
 Easy 1B/2B – Flexible power module solutions for low-power charging solutions.
- 
 HybridPACK™ 1 – Power module solutions for high-power charging solutions.
- 
 TLE4998 – Linear Hall IC family for measurement of high currents with different digital output.

# Infineon Hybrid Electric and Electric Cars Online



Infineon Technologies AG Share: € 8.11 -1.63% [Home](#) | [Where to Buy](#) | [Sitemap](#) | [Select Language](#) | [Login](#)

▶ Cross reference search

**Products** | **Applications** | **Technology** | **About Infineon**

▼ Automotive

Home > Automotive > Hybrid Electric & Electric Vehicle Solutions

Follow us: [Twitter](#) [Facebook](#) [YouTube](#) | [Share](#) | [Print](#)

## Leading and Innovative Semiconductor Solutions for Hybrid and Electric Vehicles

---

**Select a Subcategory**

- ▶ (H)EV - Main Inverter
- ▶ (H)EV - Auxiliary Inverter
- ▶ HEV - Auxiliary HV/LV DC/DC
- ▶ (H)EV - AC/DC (Battery Charger)
- ▶ Battery Management



Although electric drivetrains are already in use, further improvements are still required. Powertrain components that can play a valuable role in minimizing space and boosting performance. As a leading supplier of high-power IGBT modules for drive and traction applications for many decades now, Infineon supplied the IGBT modules that powered the TGV train, which set a new world speed record in 2007, for example. Drawing on its industrial experience, Infineon has developed dedicated (H)EV power modules delivering the ultimate in power density and efficiency.

As the world leader in advanced power and automotive electronics, Infineon has the broadest product portfolio for high-efficiency electric drivetrain designs. Combining affordability with ecology, our electromobility solutions help to significantly reduce the overall system cost of powertrain and electronics, increase mileage and improve battery efficiency. Carmakers and system suppliers can rely on best-in-class semiconductor products from Infineon Technologies to drive new innovations.

For example, active cell balancing developed by Infineon extends the life and capacity of batteries by at least 10 percent. And this is only one example. Suitable for all electric drivetrain architectures, Infineon's product portfolio comprises discrete components, power semiconductors, microcontrollers and sensors, as well as high-power modules. Thanks to our system expertise, we are able to provide complete chipsets offering optimized performance while reducing overall system costs.

Infineon's semiconductor solutions for (H)EV are testament to the company's ongoing commitment to deliver the exceptional quality and reliability that the world's leading car and automotive system manufacturers expect.

**Support**



**Download Brochures**

Brochures

▶ Download here

**Downloads**

Brochures and Application Guides

**eLearnings**

On demand trainings

eLearnings

▶ Watch here

**Mediacenter**

▶ Click here

**News**

Press Releases

▶ Download here

**Related Links**

- ▶ [Automotive Systems Entry Page](#)
- ▶ [Electromobility Website](#)
- ▶ [Innovative Semiconductor Solutions for Motorcycles, E-Bikes and Small Electric Vehicles](#)
- ▶ [White Papers & Artikel](#)
- ▶ [Entwicklungs-Tools, Software und Kits](#)
- ▶ [Microkontroller Forum](#)
- ▶ [Anwendungen für Trucks und landwirtschaftliche Fahrzeuge \(24V\)](#)

**Videos**

**Electromobility**



▶

**Characteristics of Electric Vehicle**



▶

**National Platform for e-mobility**



▶

**Research at Infineon**



▶

**Latest research projects and an outlook**



▶

**Applications**

from (H)EV-Main Inverter to Battery Management

**Downloads**

Brochures and Application Guides

**eLearning**

On demand trainings

**Videos**

Get insights from our experts

[www.infineon.com/ev](http://www.infineon.com/ev)





# Product Portfolio Overview for (H)EV Applications

## Hybrid Power Modules

### HybridPACK™ 1 – Power Module for Hybrid Electric Vehicle applications for a power range up to 20kW

Sales Name	$I_C$ [A]	$V_{CES}$ [V]	Packages	Application	Product Status
FS400R07A1E3	400	650	HybridPACK™ 1	Inverter	Released
FS400R07A1E3_S6	400	705	HybridPACK™ 1	Inverter	Released
FS200R07A1E3	200	650	HybridPACK™ 1	Inverter	Released
FS200R12A1T4	200	1200	HybridPACK™ 1	Charger	Released
FS215R04A1E3D	215	400	HybridPACK™ 1	Inverter	Released

### HybridPACK™ 1 Pin-Fin – Power Module for Hybrid Electric Vehicle applications for a power range from 20kW to 50kW

Sales Name	$I_C$ [A]	$V_{CES}$ [V]	Packages	Application	Product Status
FS400R07A1E3_H5	400	650	HybridPACK™ 1 Pin-Fin	Inverter	Released
FS200R12A1E3_H5	200	1200	HybridPACK™ 1 Pin-Fin	Inverter	Released

### Hybrid PACK™ 2 – Power Module for Hybrid Electric Vehicle applications for a power range up to 100kW

Sales Name	$I_C$ [A]	$V_{CES}$ [V]	Packages	Application	Product Status
FS800R07A2E3	800	650	HybridPACK™ 2	Inverter	Released
FS600R07A2E3	600	650	HybridPACK™ 2	Inverter	Released
FS400R12A2T4	400	1200	HybridPACK™ 2	Inverter	Released
FS800R07A2E3_B31	800	680	HybridPACK™ 2 Enhanced	Inverter	Released
FS600R07A2E3_B31	600	680	HybridPACK™ 2 Enhanced	Inverter	Released

[www.infineon.com/hybridpack](http://www.infineon.com/hybridpack)

### Automotive Easy Modules – Power Modules for auxiliaries and charger up to 10kW

Sales Name	$I_C$ [A]	$V_{CES}$ [V]	Packages	Application	Product Status
FS75R07W2E3_B11A	75	650	Automotive Easy 2B	Inverter	Released
FS50R07W1E3_B11A	50	650	Automotive Easy 1B	Inverter	Released
FS30R07W1E3_B11A	30	650	Automotive Easy 1B	Inverter	On request
F4-50R07W1H3_B11A	50	650	Automotive Easy 1B	DC/DC Converter	Released
F4-75R07W1H3_B11A	75	650	Automotive Easy 1B	DC/DC Converter	Released
FZ30R07W1E3_B31A	30	650	Automotive Easy 1B	PTC-Heater	Released

[www.infineon.com/autoeasy](http://www.infineon.com/autoeasy)

## Evaluation Kits

Board Name	SP Nummer	Description
Hybrid Kit 1 Pin-Fin	SP000889400	Evaluation Kit for applications with HybridPACK™ 1 Pin-Fin FS400R07A1E3_H5
Hybrid Kit 1+	SP000806996	Evaluation Kit for applications with HybridPACK™ 1 FS400R07A1E3
Hybrid Kit 2	SP000635950	Evaluation Kit for applications with HybridPACK™ 2 FS800R07A2E3
Easy Kit Aux Drives	SP001020068	Evaluation Kit for applications with Easy 1B FS50R07W1E3_B11A
Easy Kit DC/DC	SP001007734	Evaluation Kit for applications with Easy 1B F4-50R07W1H3_B11A

[www.infineon.com/evaluation-boards](http://www.infineon.com/evaluation-boards)



# Product Portfolio Overview for (H)EV Applications

## Automotive Gate Driver ICs

Suitable for our Power Products: EiceDRIVER™ – Single-channel IGBT Driver IC providing galvanic isolation and bidirectional signal transmission with high ambient temperature capability

Sales Name	$I_D$ [A]	$V_{BR}$ [V]	Packages	Product Status
1ED020112FTA	2	1200	PG-DSO-20	Released
2ED020112FA	2	1200	PG-DSO-36	Released
1ED020112FA2	2	1200	PG-DSO-20	Released

[www.infineon.com/automotive-eicedriver](http://www.infineon.com/automotive-eicedriver)

## Automotive Microcontrollers

### 32-bit Microcontroller Family

Sales Name	CPU Clock [MHz]	Flash [MB]	Packages	Product Status
SAK-TC277T-64F200S	200	4.0	PG-LFBGA-292	In development <sup>1)</sup>
SAK-TC275T-64F200W	200	4.0	PG-LQFP-176	In development <sup>1)</sup>
SAK-TC265D-40F200W	200	2.5	PG-LQFP-176	In development <sup>1)</sup>
SAK-TC264D-40F200W	200	2.5	PG-LQFP-144	In development <sup>1)</sup>
SAK-TC234LP-32F200F	200	2.0	PG-TQFP-144	In development <sup>1)</sup>
SAK-TC233LP-32F200F	200	2.0	PG-TQFP-100	In development <sup>1)</sup>
SAK-TC1798F-512F300EP	300	4.0	PG-BGA-512	Released
SAK-TC1782F-320F180HR	180	2.5	PG-LQFP-176	Released
SAK-TC1782N-256F133HR	133	2.0	PG-LQFP-176	Released
SAK-TC1724N-192F80HR	80	1.5	PG-LQFP-144	In development <sup>1)</sup>

Please visit [www.infineon.com/microcontrollers](http://www.infineon.com/microcontrollers) to access our broad product portfolio of automotive microcontrollers.

**Discrete IGBTs:** Please visit [www.infineon.com/discrete-igbt](http://www.infineon.com/discrete-igbt) to access our broad product portfolio of discrete IGBTs.

**Automotive MOSFETs:** Please visit [www.infineon.com/automotivemosfet](http://www.infineon.com/automotivemosfet) to access our broad product portfolio of automotive MOSFETs.

**Voltage Regulators:** Please visit [www.infineon.com/voltage-regulators](http://www.infineon.com/voltage-regulators) to access our broad product portfolio of voltage regulators.

**Sensors:** Please visit [www.infineon.com/sensors](http://www.infineon.com/sensors) to access our broad product portfolio of automotive sensors and wireless control solutions.

1) Samples on request

# Ask Infineon. Get connected with the answers.

Infineon offers its toll-free 0800/4001 service hotline as one central number, available 24/7 in English, Mandarin and German.

Our global connection service goes way beyond standard switchboard services by offering qualified support on the phone. Call us!

- Germany ..... 0800 951 951 951 (German/English)
- China, mainland .... 4001 200 951 (Mandarin/English)
- India ..... 000 800 4402 951 (English)
- USA ..... 1-866 951 9519 (English/German)
- Other countries ..... 00\* 800 951 951 951 (English/German)
- Direct access ..... +49 89 234-0 (interconnection fee, German/English)

\* Please note: Some countries may require you to dial a code other than "00" to access this international number, please visit [www.infineon.com/service](http://www.infineon.com/service) for your country!

## Where to Buy

Infineon Distribution Partners and Sales Offices:

[www.infineon.com/WhereToBuy](http://www.infineon.com/WhereToBuy)

## Stay connected

 [www.facebook.com/infineon](http://www.facebook.com/infineon)

 [www.google.com/+infineon](http://www.google.com/+infineon)

 [www.twitter.com/infineon](http://www.twitter.com/infineon)

 [www.infineon.com/linkedin](http://www.infineon.com/linkedin)

 [www.infineon.com/xing](http://www.infineon.com/xing)

 [www.youtube.com/infineon](http://www.youtube.com/infineon)

## Mobile Product Catalog

Mobile app for iOS and Android.



Infineon Technologies – innovative semiconductor solutions for energy efficiency, mobility and security.

Published by  
Infineon Technologies AG  
85579 Neubiberg, Germany

© 2014 Infineon Technologies AG.  
All Rights Reserved.

Visit us:  
[www.infineon.com](http://www.infineon.com)

Order Number: B136-H9536-G2-X-7600  
Date: 05 / 2014

### Attention please!

The information given in this document shall in no event be regarded as a guarantee of conditions or characteristics ("Beschaffensgarantie"). With respect to any examples or hints given herein, any typical values stated herein and/or any information regarding the application of the device, Infineon Technologies hereby disclaims any and all warranties and liabilities of any kind, including without limitation warranties of non-infringement of intellectual property rights of any third party.

### Information

For further information on technology, delivery terms and conditions and prices please contact your nearest Infineon Technologies Office ([www.infineon.com](http://www.infineon.com)).

### Warnings

Due to technical requirements components may contain dangerous substances. For information on the types in question please contact your nearest Infineon Technologies Office. Infineon Technologies Components may only be used in life-support devices or systems with the express written approval of Infineon Technologies, if a failure of such components can reasonably be expected to cause the failure of that life-support device or system, or to affect the safety or effectiveness of that device or system. Life support devices or systems are intended to be implanted in the human body, or to support and/or maintain and sustain and/or protect human life. If they fail, it is reasonable to assume that the health of the user or other persons may be endangered.