

Efficient Solutions for Industrial Motor Control and Drives

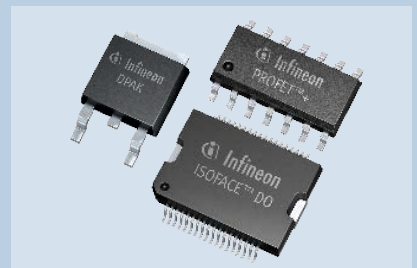

Content

Introduction	4	Low-Voltage Products	20
Low-Voltage Motor Drive Solutions	5	Industrial Power MOSFETs	20
General Information	5	ISOFACE™ – Galvanic Isolated	21
3-Phase Drives – Battery Powered	6	8-Channel High-Side Switches	
3-Phase Drives – Grid Connected	7	PROFET™ – Protected Smart	22
Stepper Motor	8	High-Side Switches	
Brush DC Motor	9	NovalithIC™ – Half-Bridges	24
		Trilith IC – H-Bridges	26
		H-Bridge and 3-Phase Gate Driver ICs	28
Support Tools	10	Monolithic H-Bridges	30
XMC1000 and XMC4400 Motor Control	10	Stepper Drivers	31
Application Kits			
300W Motor Control Application Kit and the	11	High-Voltage Products	32
Eval 5kW TO-Leadless Evaluation Board		IGBTs	32
		EiceDRIVER™ – Gate Driver IC	34
High-Voltage Motor Drive Solutions	12		
General Information	12	IGBT Modules	
3-Phase Drives – Grid Connected	13	SmartPIM and SmartPACK	35
		MIPAQ™ serve	36
Support Tools	15	Easy Modules	37
XMC Drive Cards for Low- and	15	EconoPACK™ 2 and EconoPACK™ 3 Modules	38
High-Voltage Operating Ranges		62mm IGBT Modules	39
High-Voltage Motor Control Application Kit	15	EconoPACK™ 4	41
		EconoDUAL™ 3	42
Microcontrollers	16	EconoPACK™+ D-Series	43
XMC Family	16	PrimePACK™ and IHM-B	44
DAVE™	18		
		Sensors	45
		Hall IC Switches	45
		GMR-Based Magnetic Angle Sensors	46
		TLI4970 – Current Sensor Family	47



Introduction

Energy efficiency, mobility and security are the main challenges facing modern society. Our motor control solutions address all of these needs, providing outstanding reliability, excellent quality and leading-edge innovations. This guide showcases the full range of products – from microcontrollers and gate drivers through MOSFETs, IGBTs, voltage regulators and sensors to integrated bridge driver ICs, integrated power modules and high-power modules.

For decades now, we have been working day in and day out on each of these product groups. It is our goal to consistently increase the computing performance, the switching frequency, the figure of merit, accuracy, quality

and reliability, to name only a few of many technical characteristics. As new product generations were released, each of the devices became a benchmark in its own field. But the real beauty lies in combining these individual devices and strengths to create a system – a motor control system able to set new standards in energy efficiency, dynamic behavior, robustness and longevity.

We hope you enjoy exploring the benefits of our efficient semiconductor solutions for motor control and drive applications.

Low-Voltage Motor Drive Solutions

We are the partner of choice for low-voltage motor drive solutions, providing the perfect fit across the full current range from 0.1 to 100A. The Infineon portfolio for low voltage drives is completed by XMC microcontrollers and sensors.

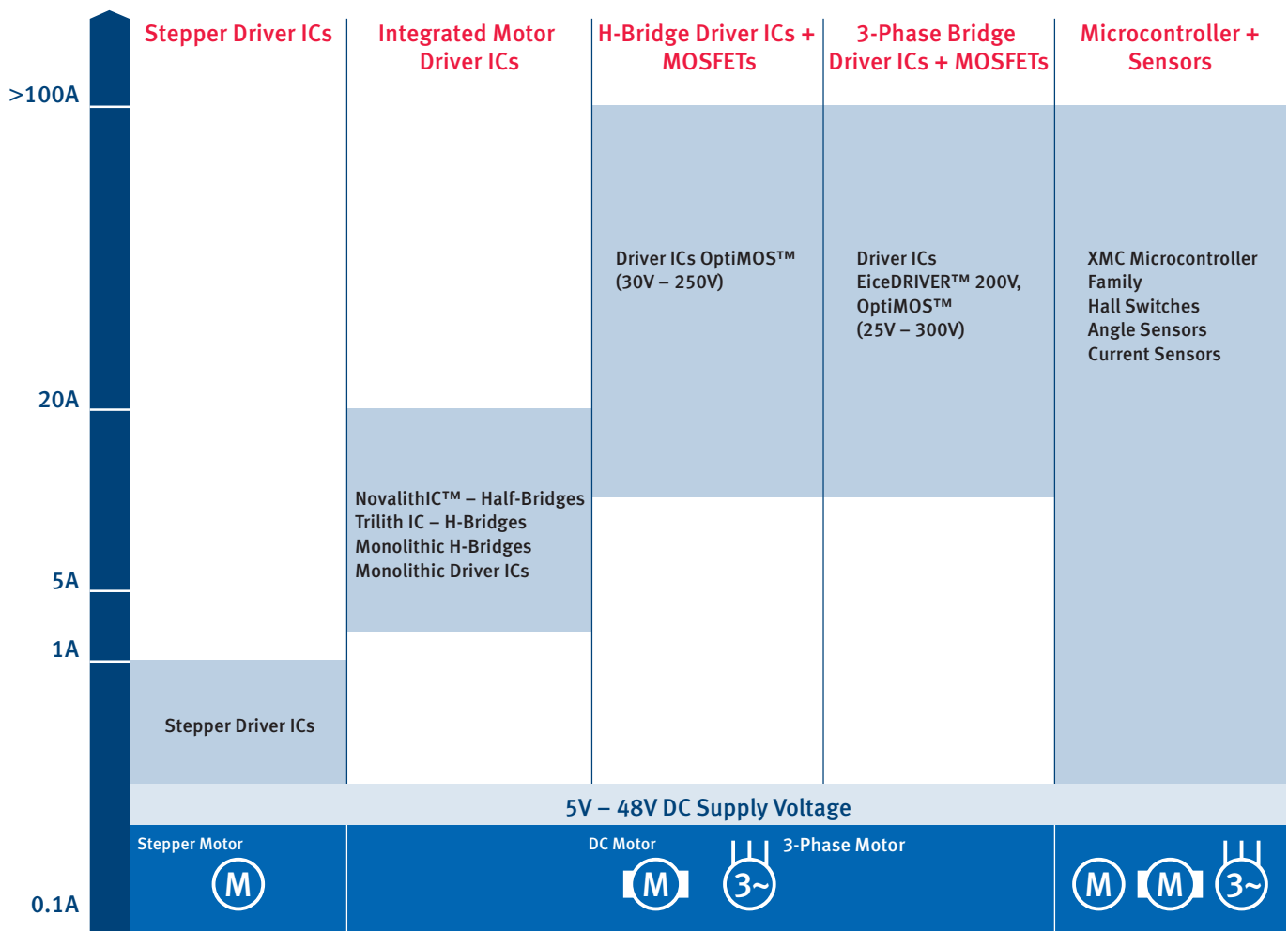

Infineon solutions cover a broad range of target low-voltage applications including



3-Phase Drives – Battery Powered

Battery-powered motor control solutions are widely used in light electric vehicles such as pedelecs and eBikes as well as cordless power tools.

Saving battery load is key, and Infineon offers the right set of devices for battery management and voltage regulation with the highest possible energy efficiency.

Not only the power management, but also the power consumption, is driven highly efficiently with the XMC microcontrollers, EiceDRIVER™ gate drivers, n-channel OptiMOS™ devices while not forfeiting precision with Infineon’s Hall, angle and current sensors.

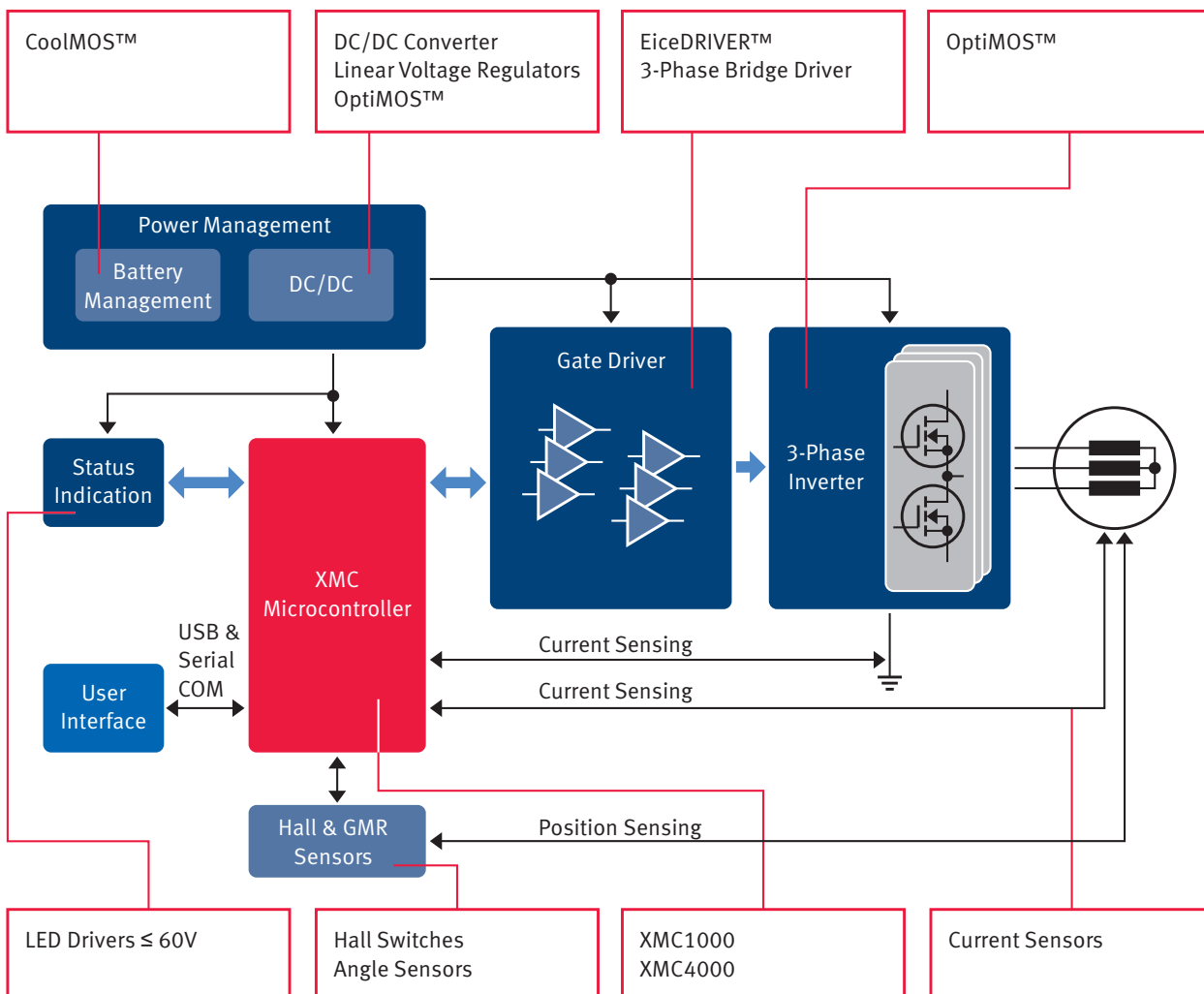

3-Phase Drives – Grid Connected

There are numerous low-voltage motor control applications, such as fans and pumps as well as actuators in home appliances with lower power ratings. Of key importance are highly efficient AC/DC and DC/DC (including voltage regulators) for power management in order to achieve the best energy-efficiency ratings.

What holds for battery-powered drives also holds for grid-connected drives. Efficiency and precision only come about with the right set of XMC microcontrollers, EiceDRIVER™ gate drivers, n-channel OptiMOST™ and Hall, angle and current sensors.

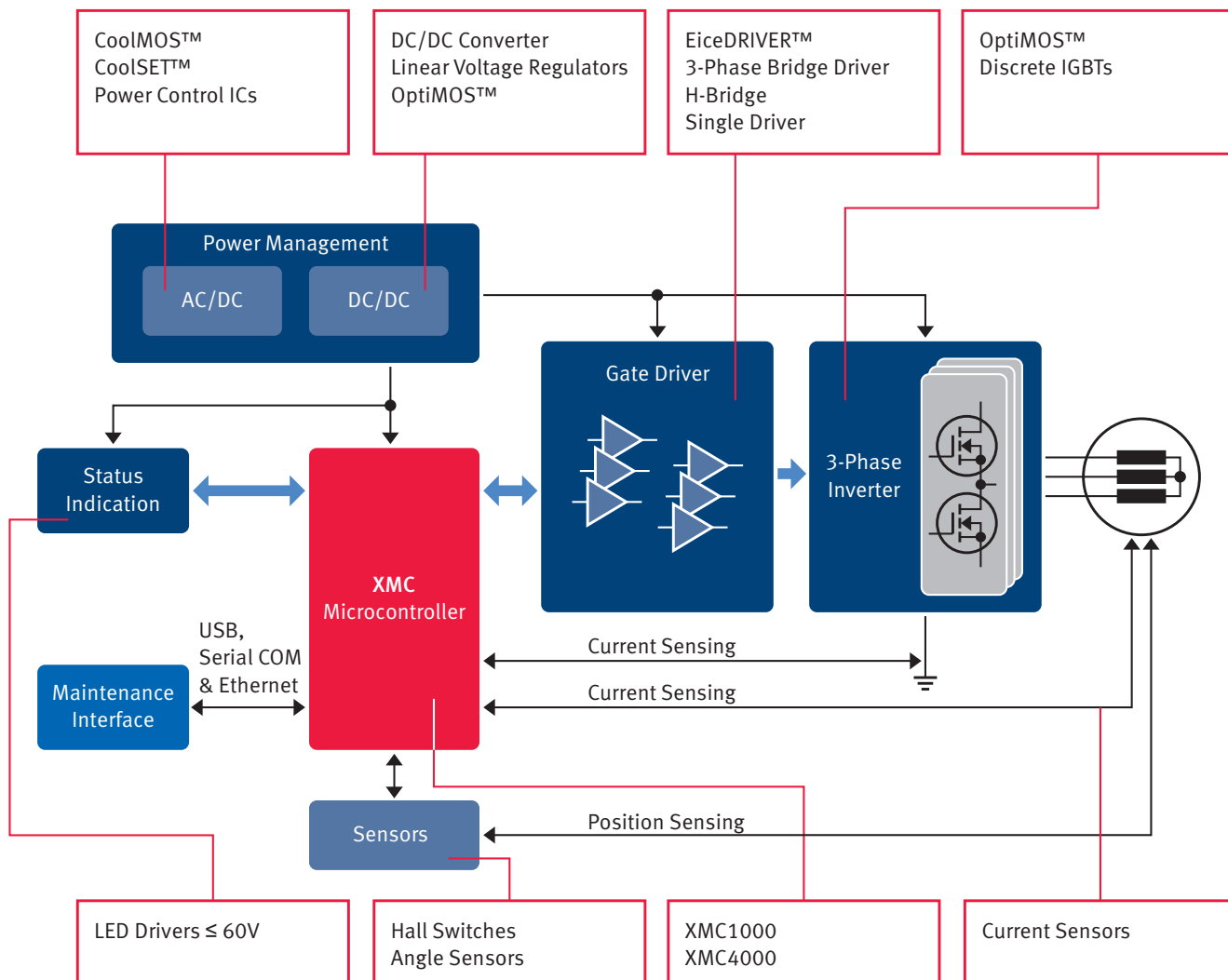

Stepper Motor

Infineon offers highly integrated stepper motor driver ICs, including control logic for current control (chopper), very low current consumption in inhibit mode and fast free-wheeling diodes.

It also provides diagnostic features for the XMC microcontrollers for short-circuit and overtemperature to achieve operating stability with a minimum of maintenance.

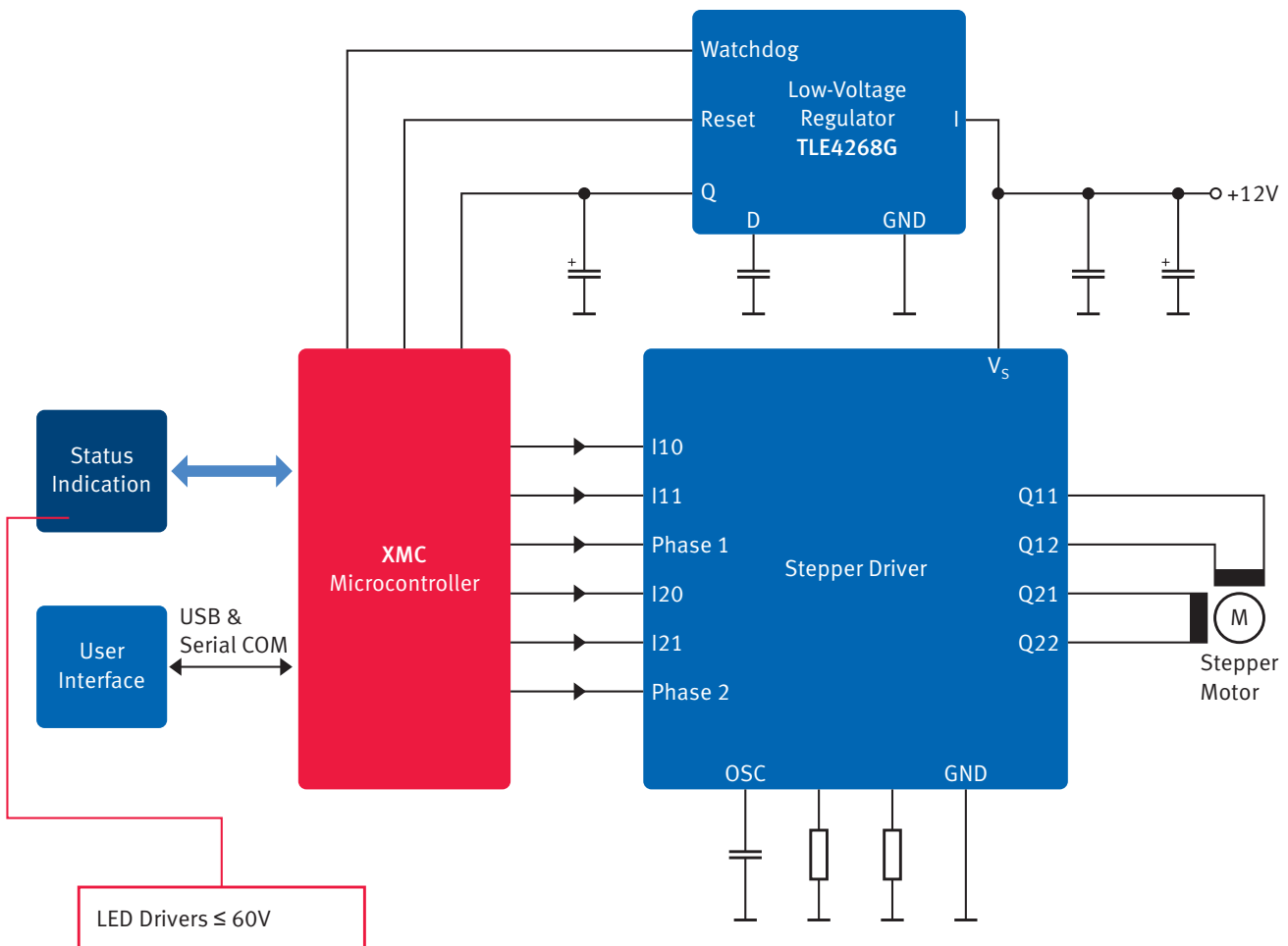

Brush DC Motor

There are three basic types of DC motors. Infineon solutions for uni-directional DC brush motor drives are integrated half-bridge drivers (NovalithIC™), PN Driver IC and protected high-side switches (PROFET™).

For bi-directional DC motors, shunt wound (bi-directional by changing connections) and permanent magnet (bi-directional by reversing current), Infineon offers integrated H-bridge drivers as Trilith IC and monolithic H-bridges.

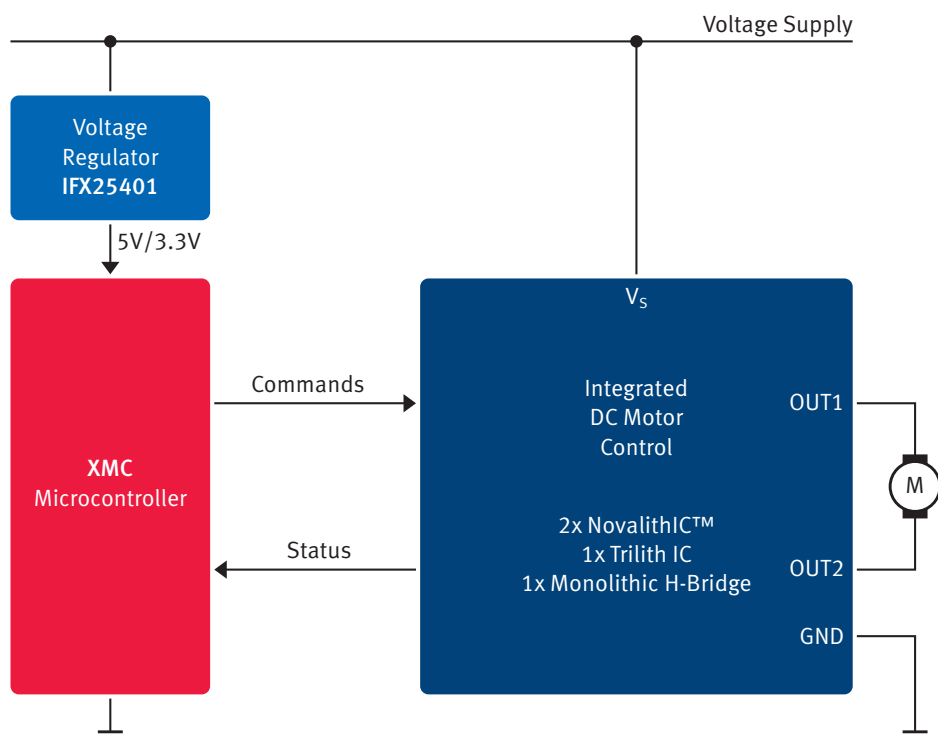

Low-Voltage Motor Control Application Kits

XMC1000 and XMC4400 Motor Control Application Kits

The XMC1000 and XMC4400 Motor Control Application Kits are ready-made evaluation kits for 3-phase drives. These two kits are best suited to customers looking for a motor control plug&play experience.

Both kits have a similar setup with a microcontroller board, the respective 24V power board including n-channel OptiMOS™ power transistors and a 3-phase

gate driver EiceDRIVER™ from Infineon, rounded off with a brushless DC motor.

Both kits are supported by the DAVE™ Motor Control Apps library, including sinusoidal and block commutation as well as various position detection and sensing schemes with encoder, Hall sensors and shunts. The XMC4400 Motor Control Application Kit also includes a resolver interface.

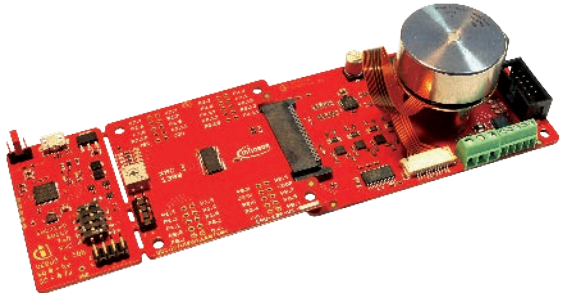
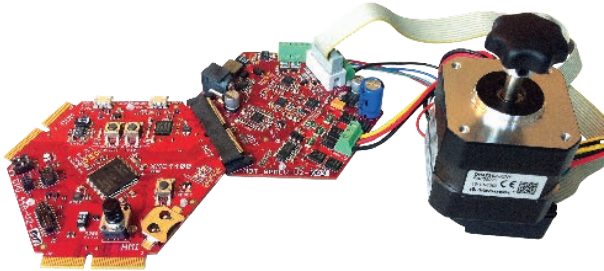
XMC1000 Motor Control Application Kit	XMC4400 Motor Control Application Kit
	
XMC1300 microcontroller (ARM® Cortex™-M0 based + Math Co-Processor)	XMC4400 microcontroller (ARM® Cortex™-M4F based)
3-Phase inverter with n-channel OptiMOS™ power transistors (BSZ0907ND) and EiceDRIVER™ gate driver (6EDL04N02PR)	3-Phase inverter with n-channel OptiMOS™ power transistors (BSC031N06NS3 G) and EiceDRIVER™ gate driver (6ED003L02-F2)
BLDC Motor from Maxon with Hall sensors	BLDC Motor from Nanotech with Hall sensors and encoder
12–24V/3.0A operating range	24V/7.5A operating range
Supported by DAVE™ Motor Control Apps library	Supported by DAVE™ Motor Control Apps library
Order Number: KIT_XMC1x_AK_Motor_001	Order Number: KIT_XMC44_AE3_001
125 €	299 €

300W Motor Control Application Kit and the Eval 5kW TO-Leadless Evaluation Board

The 300W Motor Control Application Kit is made to drive pedelecs, power tools or other low-voltage drives. The kit contains a driver and a graphical user interface (GUI) in order to make it as simple as possible to run a brushless DC motor, for example.

The Eval 5kW TO-Leadless evaluation board makes it easy to familiarize oneself with Infineon’s Power MOSFET OptiMOS™ 100V in the new TO-Leadless package. This new package is optimized for high-current applications, such as forklifts, light electric vehicles (LEV), PoL (Point of Load) and low-speed cars.

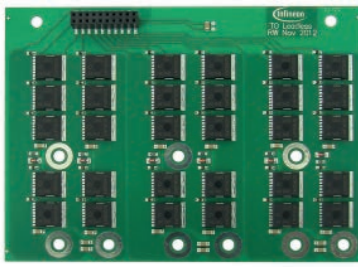
300W Motor Control Application Kit	Eval 5kW TO-Leadless Evaluation Board
	
OptiMOS™, EiceDRIVER™ and XC836	OptiMOS™ 100V in TO-Leadless package
B6 inverter topology	B6 inverter topology
Driving method: block commutation with Hall sensing	–
18–24V DC input voltage	48V DC input voltage > 100A continuous current
Switching frequency 10–24 kHz (adjustable via GUI)	Board dimensions: 200 x 250mm Components: 30 pcs. IPT020N10N3

DAVE™ – Free Development Platform for Code Generation

DAVE™ is Infineon’s high-productivity development platform for the XMC microcontroller families designed to simplify and shorten software development. Find out more about DAVE™ on page 18.

High-Voltage Motor Drive Solutions

Infineon offers gate driver ICs, discrete IGBTs, integrated modules and high-power modules across the entire power class range for high-voltage drives. No matter what the power needs of your actual application, we provide the optimized, cost-effective solution. The Infineon portfolio for high-voltage drives is also completed by XMC microcontrollers and sensors.

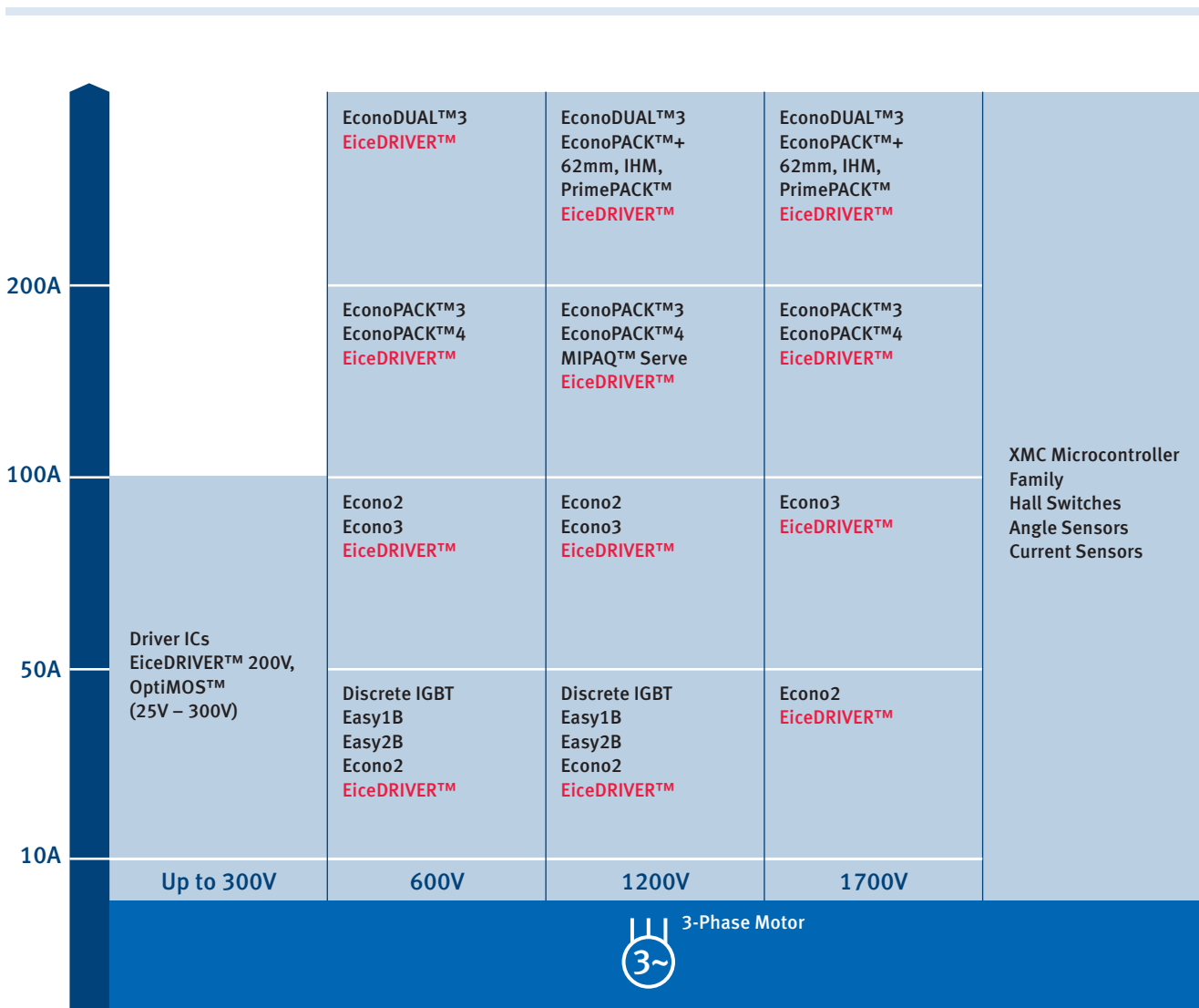

Infineon solutions cover a broad range of target high-voltage applications including



3-Phase Drives – Grid Connected

Fans and pumps with a grid-connected power supply offer a medium to high-power rating and are widely used in building infrastructure and major home appliances such as washing machines and dishwashers. The same applies for grid-connected power tools. To achieve the ultimate in efficiency and best power ratings even at this level, Infineon offers a variety of dedicated AC/DC power

management ICs and active PFC devices. In addition to the high-voltage MOSFETs, IGBTs and gate drivers, the XMC microcontrollers not only offer the right feature set for motor control but also a variety of communication standards such as USB and Ethernet as a human-machine or operator interface and for interconnecting into a building automation network.

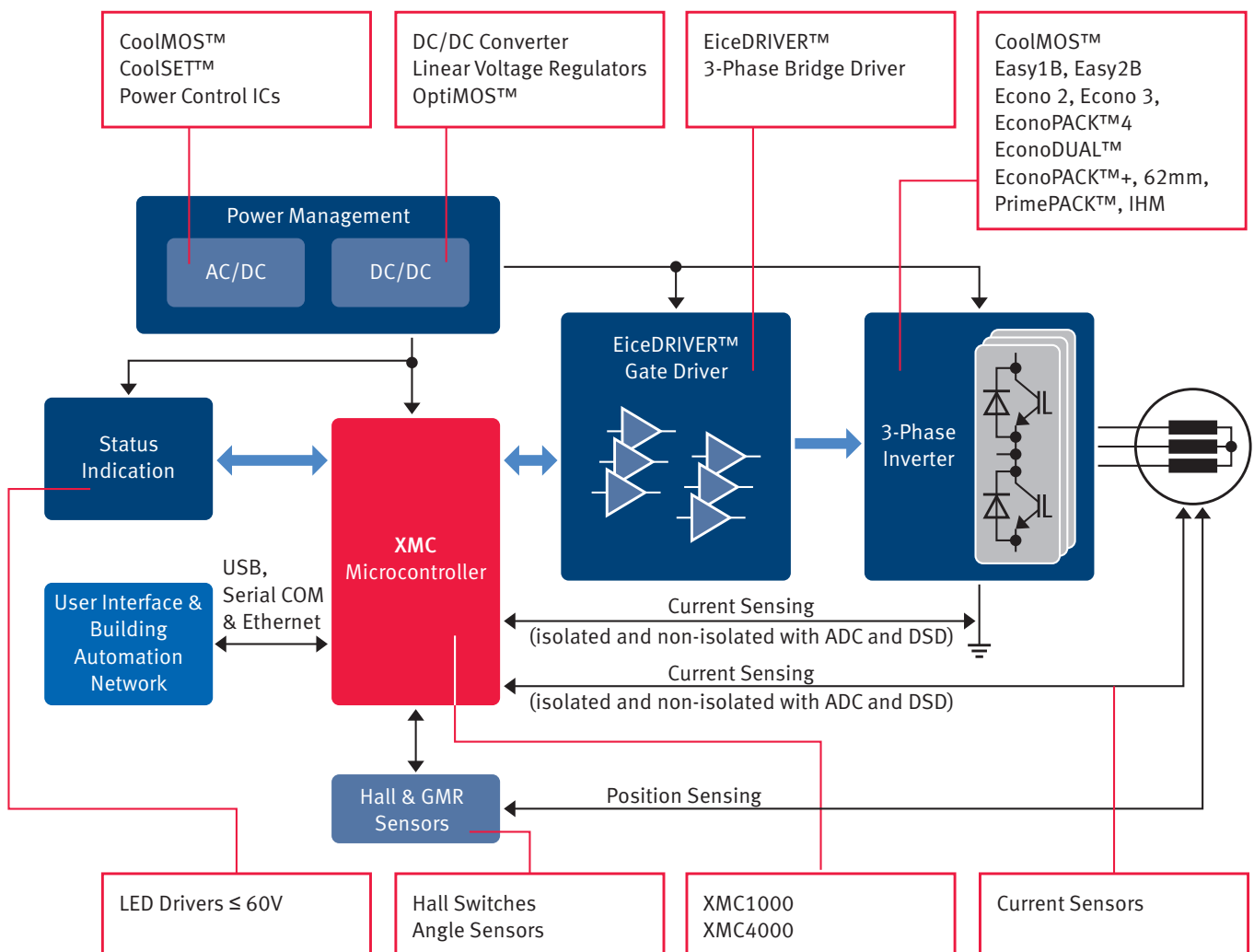

3-Phase Drives – Grid Connected

Industrial automation is the dominion of industrial AC and servo drives. These drives are heavily used in food, packaging, logistics system, tool machines and robots, to name but a few. While the pure power rating is often similar to grid-connected fans and pumps, these drives have a much higher requirement in terms of dynamic behavior and precision. The microcontroller becomes the centerpiece of such a top-notch motor control system, capable of computing the cascaded control tasks as

quickly as possible, and measuring the current, position and speed as precisely as possible. And above all, handling all the communication tasks of an industrial field bus facing very heavy demand in real-time. XMC4000 microcontrollers are the perfect choice as the way they are constructed, the way they operate, and in fact their entire DNA is destined to perform industrial motor control of the highest quality.

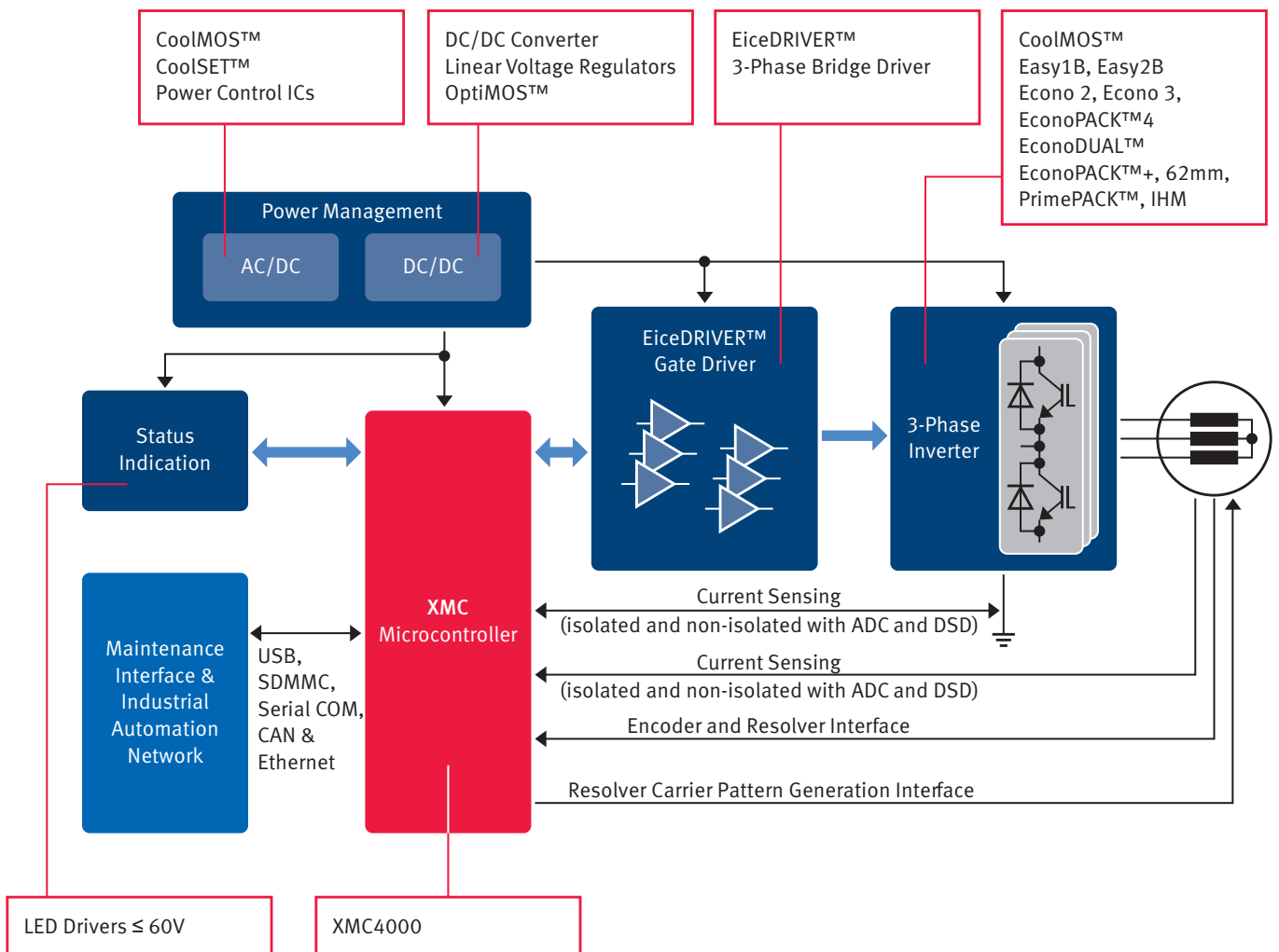

XMC Drive Cards for Low- and High-Voltage Operating Ranges

The XMC1300 and XMC4400 drive cards are microcontroller boards with galvanic isolation for evaluating 3-phase drives of up to several kilowatts. These two drive cards are best suited to customers looking to experience XMC microcontrollers and DAVE™ Motor Control Apps library with their power board/ existing Infineon power boards and their own motor.

www.infineon.com/xmc-dev

The debug interface is isolated from the XMC microcontroller and position detection interfaces in order to guarantee safe operation during software development. The XMC1300 drive card can control one 3-phase drive, while the XMC4400 drive card can control up to two. The DAVE™ Motor Control Apps library, together with xSPY for software development and motor parameterization, is the best fit for the XMC1300 and XMC4400 drive cards.

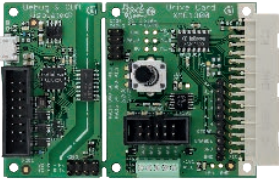
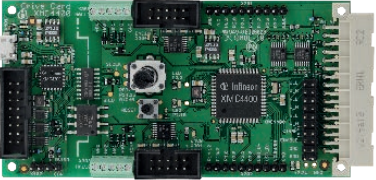
XMC1300 Drive Card	XMC4400 Drive Card
	
XMC1300 microcontroller (ARM® Cortex™-M0 based + Math Co-Processor)	XMC4400 microcontroller (ARM® Cortex™-M4F based)
On-board J-Link lite debugger with galvanic isolation	On Board J-Link lite debugger with galvanic isolation
Hall interface	2x Hall interface
Encoder Interface	2x Encoder Interface
Supported by DAVE™ Motor Control Apps library	Supported by DAVE™ Motor Control Apps library
Order Number: KIT_XMC1300_DC_V1	Order Number: KIT_XMC4400_DC_V1
69 €	109 €

High-Voltage Motor Control Application Kit

The XMC 750 Watt Motor Control Application Kit is a ready-made evaluation kit for 3-phase drives of up to 750 watts. This kit is best suited to customers looking to experience XMC microcontrollers, the DAVE™ Motor Control Apps library and the new 750 watt power board from Infineon with their own motor. It includes the XMC1300 and XMC4400 drive cards with galvanic isolation. The power board includes off-the-grid supply with input filter, active PFC and the 3-phase inverter bridge built on the broad Infineon power product portfolio including PFC IC, Silicon Carbide Diode, gate driver and IGBTs. The XMC 750 Watt Motor Control Application Kit is supported by the DAVE™ Motor Control Apps library.



DAVE™ – Free Development Platform for Code Generation

DAVE™ is Infineon’s high-productivity development platform for the XMC microcontroller families designed to simplify and shorten software development. Find out more about DAVE™ on page 18.

www.infineon.com/motorcontrol



XMC Family – 32-bit Microcontrollers with ARM® Cortex™-M Cores

The XMC microcontroller portfolio features a wide range of products from low-end, low-pin-count devices up to advanced solutions for industrial applications that demand energy efficiency, high quality standards, long product lifetimes and high temperature robustness.

Common peripherals and development tools across the family ensure a high level of scalability and compatibility between all family members. DAVE™, Infineon's unique and revolutionary framework for all XMC products, accelerates and simplifies development efforts.

XMC1000 Family – 32-bit Microcontroller based on ARM® Cortex™-M0

The XMC1000 offers the largest flash memory spectrum, scaling from 8KB to 200KB. Three different series cover a range of application fields. The XMC1100 series is designed for easy entry into the XMC world. The XMC1200 line features peripherals for LED lighting and HMI designs and the XMC1300 series addresses the real-time control needs of motor control or digital power conversion applications. Leveraging Infineon's competence as the number 1 worldwide in security microcontrollers,

XMC1000 products deliver effective software IP protection functionality. The XMC1100, XMC1200, and XMC1300 support software re-use within the complete XMC family plus the easy interchange of hardware with certain pin-compatible packages. Development boards for the XMC1000 range from boot kits for easy initial evaluation to application kits for more specific application-oriented work.

XMC4000 Family – 32-bit Microcontroller based on ARM® Cortex™-M4

Infineon's XMC4000 family of microcontrollers is tailored to power industrial applications with a need for advanced motor controls. Its unique combination of Infineon's leading-edge timers, PWM and analog

front-end peripherals with the real-time and signal processing capabilities of the ARM® Cortex™-M4 makes the XMC4000 the ideal solution for industrial drive applications.

XMC Family Product Portfolio

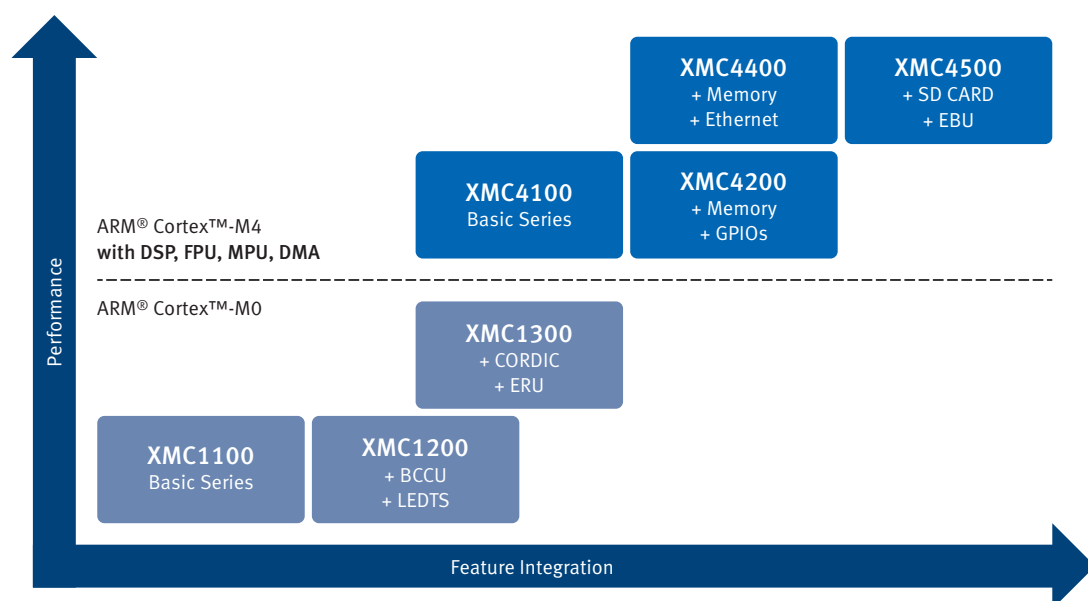

XMC Microcontroller Portfolio – Lineup

Numbers are 'UP TO'. For all details, see Reference Manual.	XMC11x	XMC12x	XMC13x	XMC41x	XMC42x	XMC44x	XMC45x
ARM® Processor	Cortex™-M0			Cortex™-M4 with built-in DSP			
MHz	32			80	120		
CO-Processor	–		Math-Co Processor (CORDIC)	Floating Point Unit (SPFPU)			
DMA/MPU	–			8ch/8 Regions	8ch / 8 Regions	12ch / 8 Regions	
Flash/RAM/Cache [KB]	8 ~ 200 / 16/no			128 ~ 256/20 ~ 40/1	256 ~ 512/ 80/4	512 ~ 1M/ 128 ~ 160/4	
Packages (number of Pins)	16/24/28/38/40			48/64		64/100	100/144
ETH/USB/EBU	–			no/FS DEV/no		IEEE1588 / FS OTG/no	IEEE1588 / FS OTG/yes
CAN/SDMMC	–			2 nodes/no			3 nodes/yes
USIC (UART/LIN, IIC, IIS, Standard-/Dual-/Quad-SPI)	4ch (2 USICs)			8ch (4 USICs)			12ch (6 USICs)
High-Resolution PWM (HRPWM) Delta Sigma Demodulator (DSD) Position Interface (POSIF)	–	–	no no 1x	1x no 1x	1x 4x 2x	1x 4x 2x	no 4x 2x
ADC/DAC	12ch/no	12ch (2x Sample)/yes		9ch (2x Sample)/2ch		26ch (4x Sample)/2ch	
CMP	–	2x	3x	see HRPWM (with built-in CMPs)			–
PWM Unit CCU4 (single-side) PWM Unit CCU8 (high & low-side)	4ch no		4ch 4ch	8ch 4ch	8ch 4ch	16ch 8ch	16ch 8ch
Touch & LED Display Matrix (Lighting) LED Dimming (Lighting) LED Color Control Power LED	–	yes yes yes yes	no yes yes yes	8ch Touch 64 LEDs – –			
Operating Voltage	1.8 ~ 5.5V			3.13 ~ 3.63V			
Operating Temperature	-40°C ~ 85°C/105°C			-40°C ~ 85°C/125°C			
Ecosystem & Enablement	Infineon DAVE™: FREE Eclipse-based IDE, CMSIS and MISRA compliant, GCC with Debugger, DAVE™ Apps Code Generation, open for 3 rd Party Tools such as KEIL, IAR, ...						

DAVE™ – Free Development Platform for Code Generation

DAVE™ Includes

- Eclipse CDT-based IDE with improved project management
- GNU c-compiler tools
- Debugger incl. flash loader
- Code generation plug-in with graphical user interfaces
- A resource solver provides automatic or constrained assignment of chip resources to the DAVE™ Apps
- Library manager to download and manage the DAVE™ Apps
- xSPY data visualization tool
- Can be used with 3rd party tools and software
- DAVE™ version 3 supports the XMC1000 and XMC4000 families

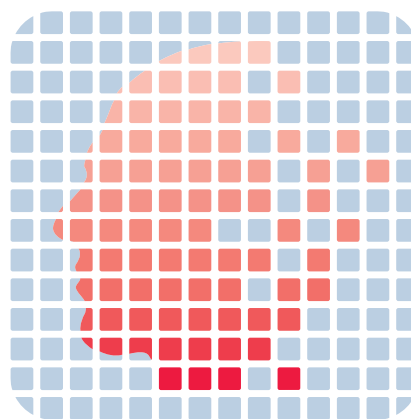

Currently, there are more than 160 DAVE™ Apps available that cover a wide range of different application use cases as depicted in the diagram at the top of the opposite page. New DAVE™ Apps or updates are released monthly (end of the month). Download the complete list of currently available DAVE™ Apps.

DAVE™ Supports all Motor Control Kits and Drive Cards

Ready-made motor control example projects based on the DAVE™ Motor Control Apps library.

Project	Description	Target MCU Series
Webserver XMC4500_Relax_Kit	XMC4500 Webserver Demo for the Relax Kit XMC4500	XMC4500
7-segment display functionality using DISP_7SEG app	This example demonstrates how the XMC1200 can control eight 7-segment displays with shared cathodes using the DISP_7SEG01 app.	XMC1200
AC Induction Motor V/F control ACIMVF01_Example1	Open loop constant V/F control of the AC induction motor. Motor speed can be changed by adjusting the POT value.	XMC1300
AC Induction Motor V/F control ACIMVF01_Example1	Open loop constant V/F control of the AC induction motor. Motor speed can be changed by adjusting the POT value.	XMC4200
AC Induction Motor V/F control ACIMVF01_Example1	Open loop constant V/F control of the AC induction motor. Motor speed can be changed by adjusting the POT value.	XMC4400
ADC Conversion ADC001_Example1	AOC_Example: This example demonstrates the VADC background request source.	XMC1200
BLDC Motor control with 3 Hall sensor feedback BLDCBCH03_Example1	BLDC motor control with 3 Hall sensor position feedback and voltage control technique. It uses the adaptive Hall feature to detect the Hall patterns of the motor in open loop and switches to closed loop with voltage control technique. Speed can be controlled via POT.	XMC1300
BLDC Motor control with 3 Hall sensor feedback BLDCBCH03_Example1	BLDC motor control with 3 Hall sensor position feedback and voltage control technique. It uses the adaptive Hall feature to detect the Hall patterns of the motor in open loop and switches to closed loop with voltage control technique. Speed can be controlled via POT.	XMC4200
BLDC Motor control with 3 Hall sensor feedback BLDCBCH03_Example1	BLDC motor control with 3 Hall sensor position feedback and voltage control technique. It uses the adaptive Hall feature to detect the Hall patterns of the motor in open loop and switches to closed loop with voltage control technique. Speed can be controlled via POT.	XMC4400
BLDC Motor Sensorless Block Commutation BLDCBCL01_Example1	Sensorless (BEMF detection) control of BLDC motor and voltage control technique. It runs the motor in open loop during startup and switches to closed loop with voltage control technique. Speed can be controlled via POT.	XMC1300
CAN Communication CAN001_Example1	This example project uses two CAN001 apps to communicate between two CANs.	XMC4500

DAVE™ Apps from Motor Control Library

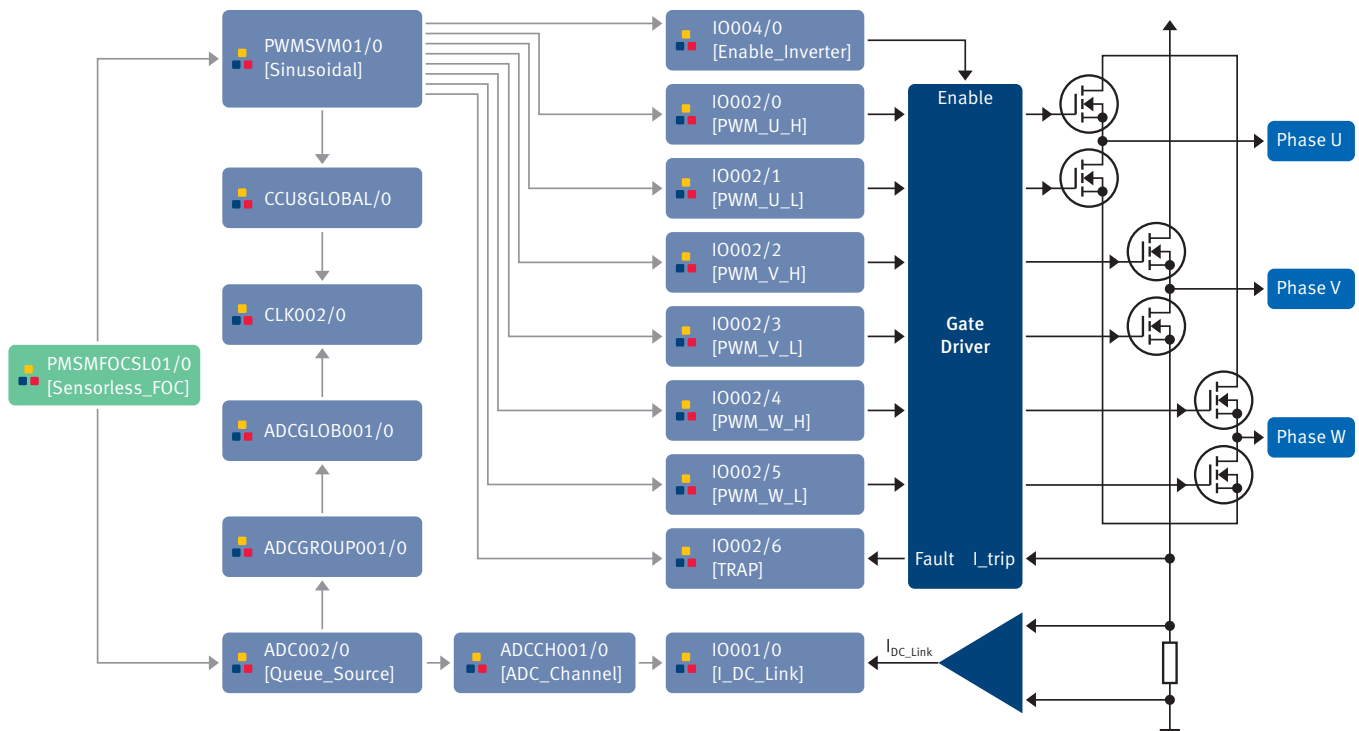

xSPY Soft Oscilloscope for Real-time Monitoring and Parameterization



To download DAVE™ for free, see all DAVE™ Apps and explore the DAVE™ forum, please visit www.infineon.com/dave.

Industrial Power MOSFETs – OptiMOS™ for Highest Performance in your Drive Applications

The field of motor drives (high-current applications) requires a wide range of system power MOSFETs which enable:

- An extension of range and battery lifetime,
- Reliable operation in harsh environments,
- System miniaturization and cost reduction
- And optimized thermal management.

Infineon’s low-voltage OptiMOS™ MOSFET family is the right choice for drives applications. The broad and comprehensive portfolio offers the perfect product for all motor control systems up to 110V DC.

Key Features

- High-current capability
- Lowest on-state resistance $R_{DS(on)}$
- Ease of use
- Outstanding product performance and quality

Low-Voltage Power MOSFET Recommendation

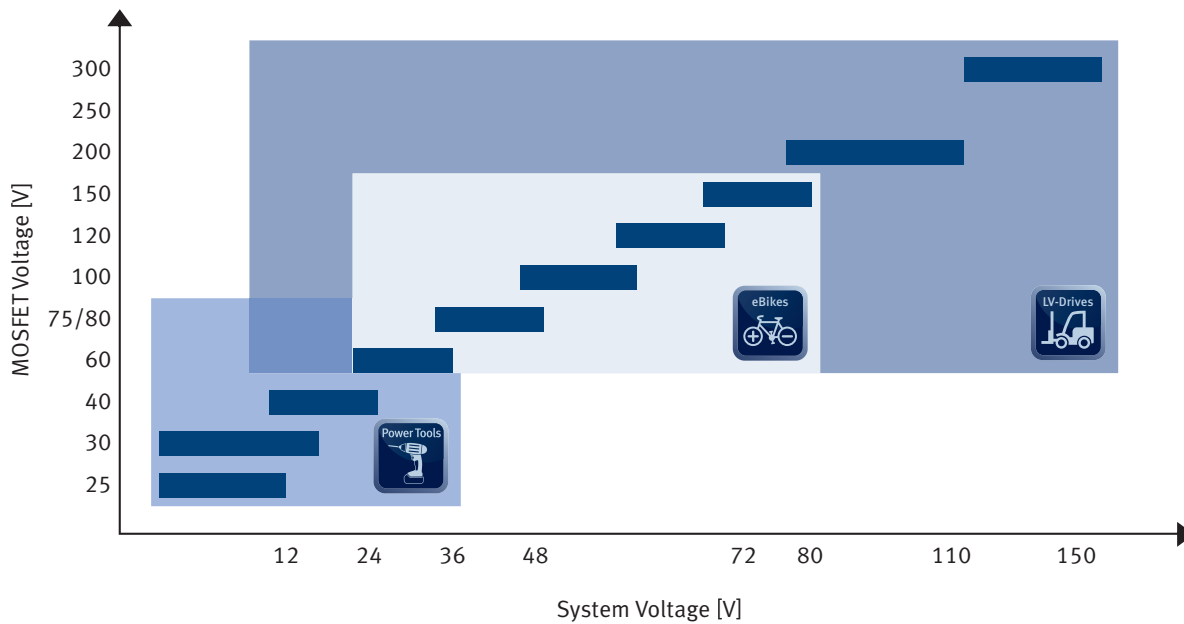

Cordless Tools		Light Electric Vehicles		
Brushed DC 12–36V	Brushless DC 12–36V	Pedelecs 24–36V	eScooters 36–48V	Low speed cars 48–72V
OptiMOS™ 20–60V	OptiMOS™ 20–60V	OptiMOS™ 60–80V	OptiMOS™ 75–100V	OptiMOS™ 3 100–150V
TO-220 D²PAK	SuperSO8 CanPAK™	SuperSO8 D²PAK	TO-220 D²PAK	TO-Leadless D²PAK/D²PAK 7-pin

ISOFACE™ – Galvanic Isolated 8-Channel High-Side Switches for Industrial Control Applications

The ISO 1H81xG is a robust, galvanically isolated high-side IC used to protect the 3.3V/5V control domain from stringent process side supporting up to 35V. It can be deployed in various industrial control environments, namely PLC, distributed control systems, robotics and across general control equipment.

The embedded isolation and high-side switch simplifies the hardware and software design along with intelligent diagnostics such as short-circuit protection and overtemperature shutdown. The device facilitates ease of connection with control-side devices such as μC , μP , ASIC or FPGA.



Key Features

- Integrated galvanic isolation 500 V_{rms}: EN61131-2, UL508
- Direct interface to μC 3.3V/5V serial or parallel
- Short-circuit protection
- Inductive load switching up to 1.2H
- Up to 1.2A load current
- Integrated diagnostics: overload & short-circuit, undervoltage detection (load-side)

Key Benefits

- Avoids aging opto-couplers
- Fail-safe
- No need for external clamping diodes
- System maintenance support

Typical Application

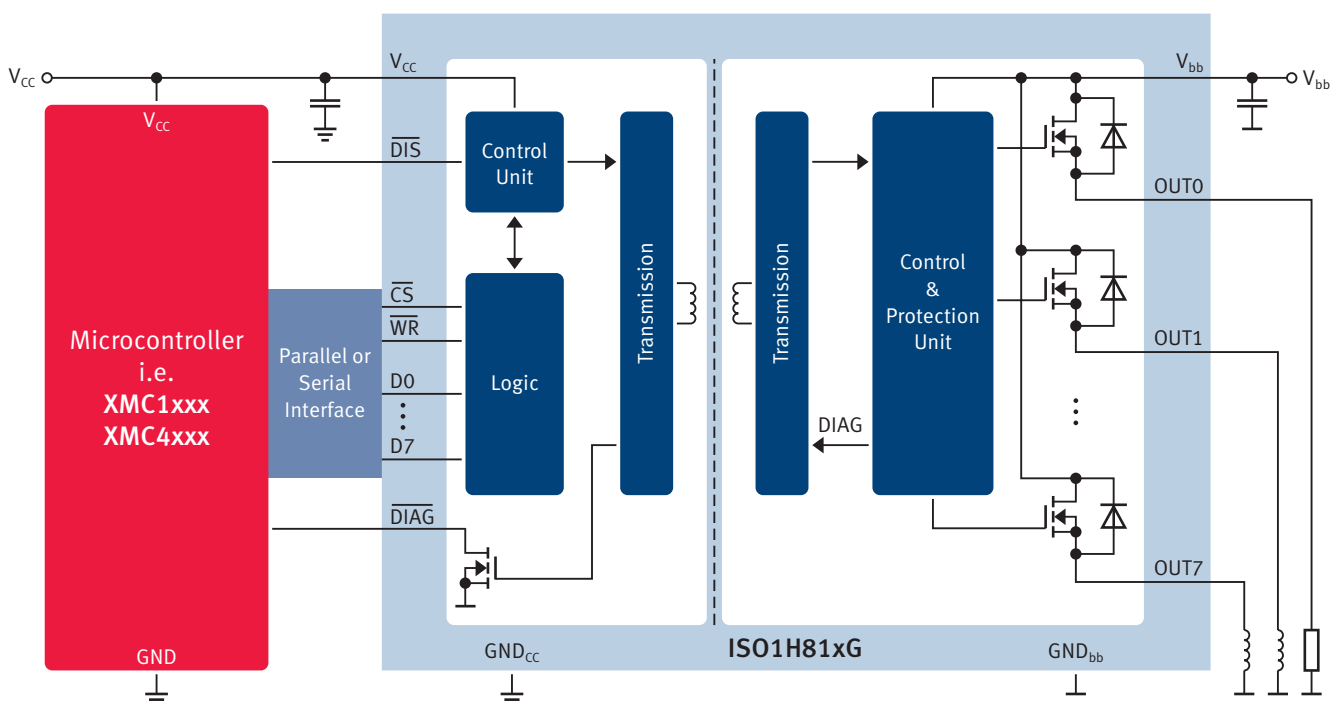

PROFET™ – Protected Smart High-Side Switches

Infineon's PROFET™ products are high-side switches placed between the supply and load in order to control the application. The high-side switches comprise a broad range of smart features, including diverse protection and diagnostic functions. Since the PROFET™ products are capable of addressing all kinds of resistive, capacitive and inductive loads, they can be used in a big variety of industrial applications.

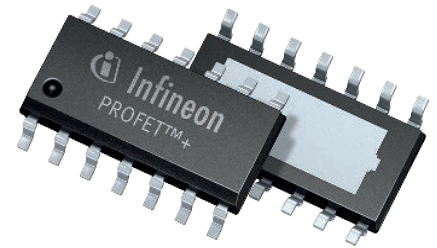

Basic Features

- High-side switches
(0.5 ... 45A load current)
- RoHS compliant
- Very low stand-by current
- ESD protection, optimized EMC
- PWM capability
- Very low power DMOS leakage current in OFF
- 3.3V and 5V compatible logic inputs

Protection Features

- Load dump
- Current limitation
- Thermal shutdown
- Loss of ground/battery protection
- Stable behavior at undervoltage
- Overvoltage protection (ext. components)
- Reverse polarity compliant

Diagnostic Features

- Proportional load current sense
- Open-load in ON- and OFF-State
- Short-circuit to battery and ground
- Overtemperature sense

Product Table PROFET™+ 24V and High-Current PROFET™ (Automotive Grade)

Product Type	Product Family	$R_{DS(on)}$ (typ) [mΩ]	Nominal Load Current [A]	E_{AS} [mJ]	Recommended Operating Voltage Range [V]	$I_{L(SC)}$ (typ) [A]	Packages
BTT6050-1EKA	PROFET™+ 24V	50.0	4.5	55 @ 4A	5.0 ... 48.0	47	SO14 EP
BTT6050-2EKA	PROFET™+ 24V	50.0	2 x 3.0	55 @ 4A	5.0 ... 48.0	47	SO14 EP
BTT6030-2EKA	PROFET™+ 24V	30.0	2 x 4.0	50 @ 4A	5.0 ... 48.0	70	SO14 EP
BTT6030-1EKA	PROFET™+ 24V	30.0	6.0	50 @ 6A	5.0 ... 48.0	70	SO14 EP
BTT6020-1EKA	PROFET™+ 24V	20.0	7.0	100 @ 7A	5.0 ... 48.0	88	SO14 EP
BTF50060-1TEA ¹⁾	High-Current PROFET™	6.0	13.5	280 @ 20A	4.7 ... 28.0	75	PG-T0252-5
BTS6163D	High-Current PROFET™	20.0	6.5	250 @ 20A	5.5 ... 62.0	70	PG-T0252-5
BTS50085-1TMA	High-Current PROFET™	9.0	11.0	1200 @ 20A	5.5 ... 58.0	90	PG-T0263-7
BTS50085-1TMB	High-Current PROFET™	9.0	11.0	1200 @ 20A	5.5 ... 58.0	90	PG-T0220-7
BTS50055-1TMA	High-Current PROFET™	6.0	17.0	1500 @ 20A	5.0 ... 34.0	130	PG-T0263-7
BTS50055-1TMB	High-Current PROFET™	6.0	17.0	1500 @ 20A	5.0 ... 34.0	130	PG-T0220-7
BTS550P	High-Current PROFET™	3.5	35.0	3000	5.0 ... 34.0	220	PG-T0218-5
BTS555	High-Current PROFET™	2.5	45.0	3000	5.0 ... 34.0	400	PG-T0218-5

1) Speed PROFET™, capable for PWM up to 25kHz.

Block Diagram of Dual Channel PROFET™+ 24V Family Members

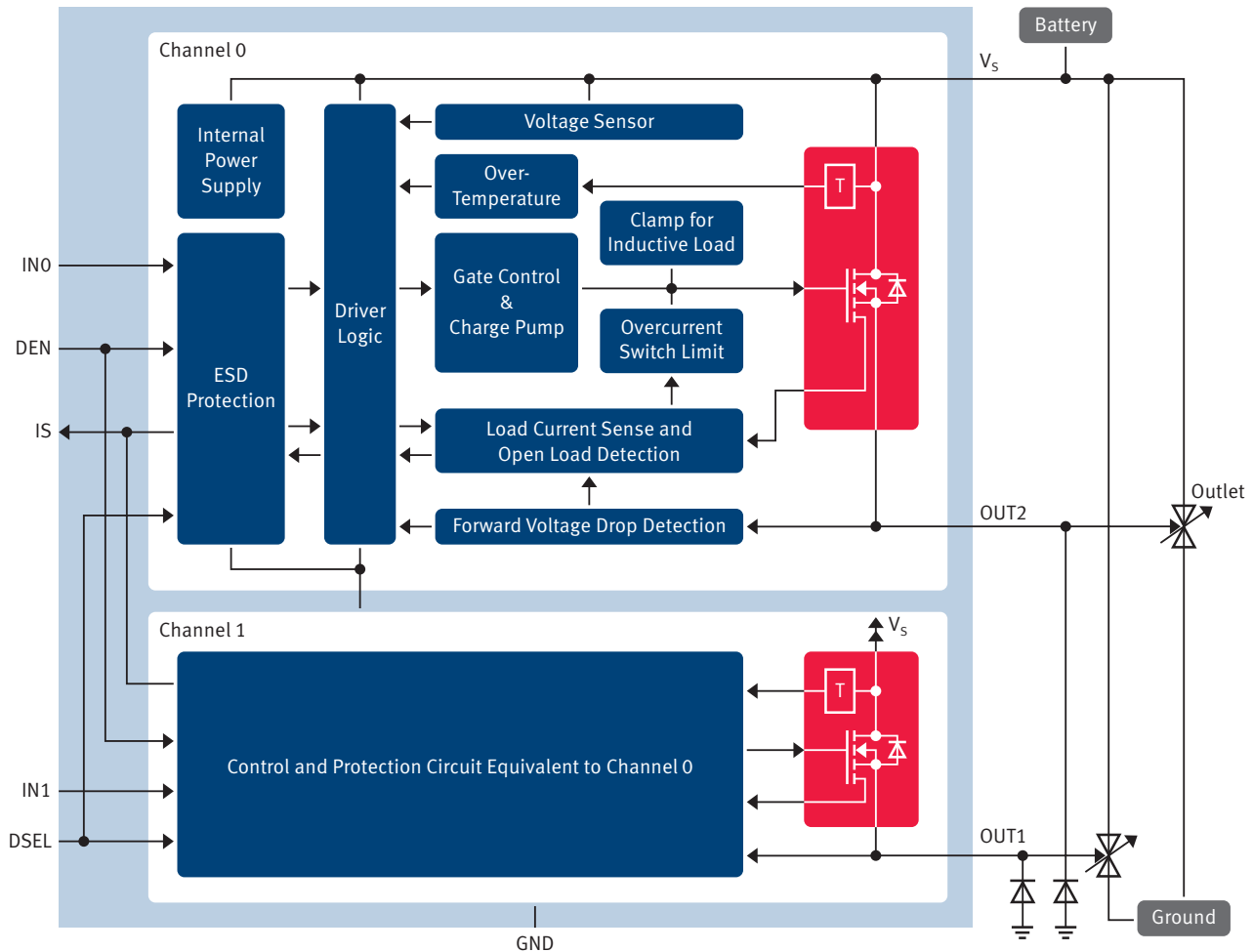

Product Table Industrial PROFET™

Product Type	Product Family	$R_{DS(on)}$ (typ) [mΩ]	Nominal Load Current [A]	E_{AS} [mJ]	Recommended Operating Voltage Range [V]	$I_{L(SC)}$ (typ) [A]	Packages
ISP752T	Industrial PROFET™	200	1.3	125	6.0 ... 52.0	6.5	PG-DSO-8
ITS4200S-ME-O	Industrial PROFET™	200	0.7	700	11.0 ... 45.0	3.0	PG-SOT223-4
ITS4200S-ME-P	Industrial PROFET™	200	1.4	160	11.0 ... 45.0	3.0	PG-SOT223-4
ITS4100S	Industrial PROFET™	100	2.4	870	5.0 ... 34.0	10.0	PG-DSO-8
ITS4060S	Industrial PROFET™	60	3.1	900	5.0 ... 34.0	17.0	PG-DSO-8
ITS4200S-SJ-D	Industrial PROFET™	200	1.2	125	6.0 ... 52.0	6.5	PG-DSO-8
ITS711L1	Industrial PROFET™	200	1.0	150	5.0 ... 35.0	7.5	PG-DSO-20
ITS716G	Industrial PROFET™	140	1.0	76	5.5 ... 40.0	9.0	PG-DSO-20
ITS724G	Industrial PROFET™	90	2.0	120	5.5 ... 40.0	15.0	PG-DSO-20
ITS5215L	Industrial PROFET™	90	2.0	178	5.5 ... 40.0	15.0	PG-DSO-12
ITS428L2	Industrial PROFET™	60	7.0	190	4.75 ... 41.0	22.0	PG-TO252-5

Half-Bridges – How to Drive Unidirectional DC Motors

NovalithIC™: Integrated Half-Bridge Driver

The NovalithIC™ provides a complete, low-ohmic protected half-bridge in a single package (typ. path resistance @ 25°C down to 10mΩ). It can also be combined with an additional NovalithIC™ to create a H-bridge or 3-phase bridge. The NovalithIC™ family has the capability to switch high-frequency PWM while providing overcurrent, overvoltage and overtemperature protection. The NovalithIC™ family offers cost-optimized, scalable solutions for protected high-current PWM motor drives with very restrictive board space. The NovalithIC™ includes a P-N MOSFET enabling a significant reduction of EME (Electro Magnetic Emissions) and power dissipation thanks to an optimized switching shape and the absence of a charge pump.

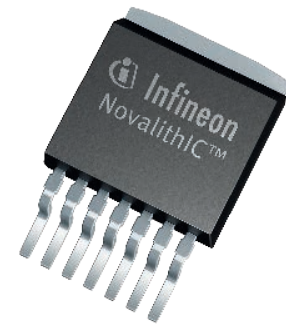

Basic Features

- Low quiescent current
- Capable for high PWM frequency
- Logic level input
- Adjustable slew rate
- Cross-current protection

Protection Features

- Overtemperature shutdown
- Overvoltage (lockout or smart clamp)
- Undervoltage
- Overcurrent

Diagnostic Features

- Overtemperature
- Overvoltage
- Overcurrent
- Current sense and status

Application Example for High-Current PWM Motor Drives

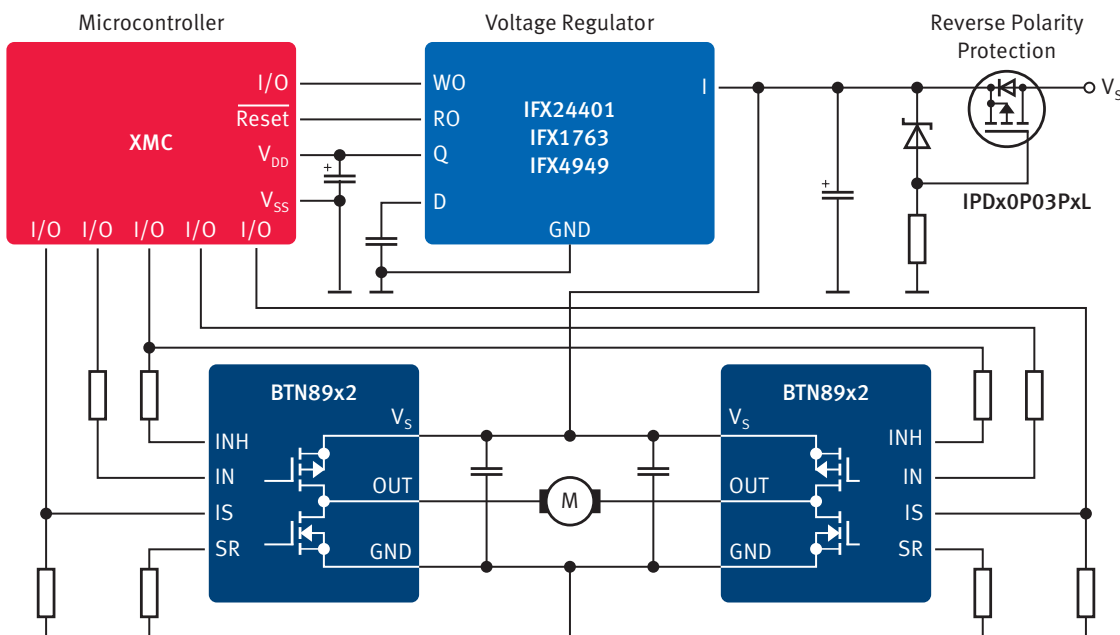

NovalithIC™ Product Overview

Product Type	Operating Range [V]	$R_{DS(on)}$ Path (typ) [mΩ]	$I_{D(lim)}$ (typ) [A]	I_q (typ) [μA]	Switch Time (typ) [μs]	Diagnosis	Protection	Package
BTN8962TA	5.5 ... 40.0	14.2	42	7	0.25	OT, OC, CS	UV, OT, OC	PG-TO-263-7
BTN8982TA	5.5 ... 40.0	10.0	70	7	0.25	OT, OC, CS	UV, OT, OC	PG-TO-263-7

1) HS switch only
 CS = Current Sense
 OC = Overcurrent
 OT = Overtemperature

Gate Driver ICs for External MOSFETs – PN Driver IC

In addition to our highly-rated H-bridge and 3-phase gate driver ICs, Infineon is pleased to introduce its new PN half-bridge gate driver IC. The IPN10EL-S is designed to drive one high-side P-channel MOSFET and one low-side c-channel MOSFET for half-bridge and other motor control applications. As no charge pump is required for the P-channel high-side MOSFET, cost-optimized solutions can be achieved.

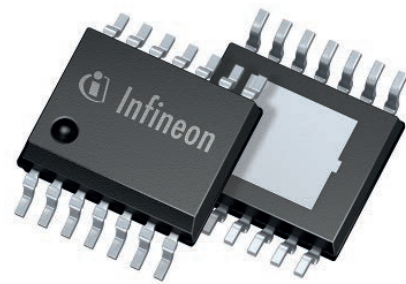

Product Type	Operating Range	Adjustable Dead Time	Reverse Polarity Protection	Diagnosis	Package
IPN10EL-S	4.0 ... 40.0	Yes	No	UV, OT, SCD	PG-SSOP-14

Trilith IC – Integrated H-Bridge Driver

The Trilith IC family members combine two high-side and two low-side switches in a single package. They are designed to drive high-current DC motors in a H-bridge configuration (peak currents of up to 42A), but can also be used as single independent switches. All Trilith ICs include overcurrent and overtemperature protection for high-side switches. For low-side switches, designers can choose between fast unprotected switches and protected switches for lower frequencies (typ. path resistance @ 25°C from 210mΩ down to 40mΩ). The third generation of Trilith IC (BTM7742G/BTM7745G/BTM7752G/BTM7755G) is based on the NovalithIC™ concept and includes P-N MOSFET. This enables a significant reduction of EME (Electro Magnetic Emissions) and power dissipation thanks to an optimized switching shape and the absence of a charge pump.



Basic Features

- Low quiescent current
- Capable for high PWM frequency

Protection Features

- Overvoltage
- Undervoltage
- Overtemperature
- Short-circuit/overcurrent detection

Diagnostic Features

- Overvoltage
- Overtemperature
- Short-circuit/overcurrent detection
- Current sense/status
- Open-load

Application Example for DC Brush Motors

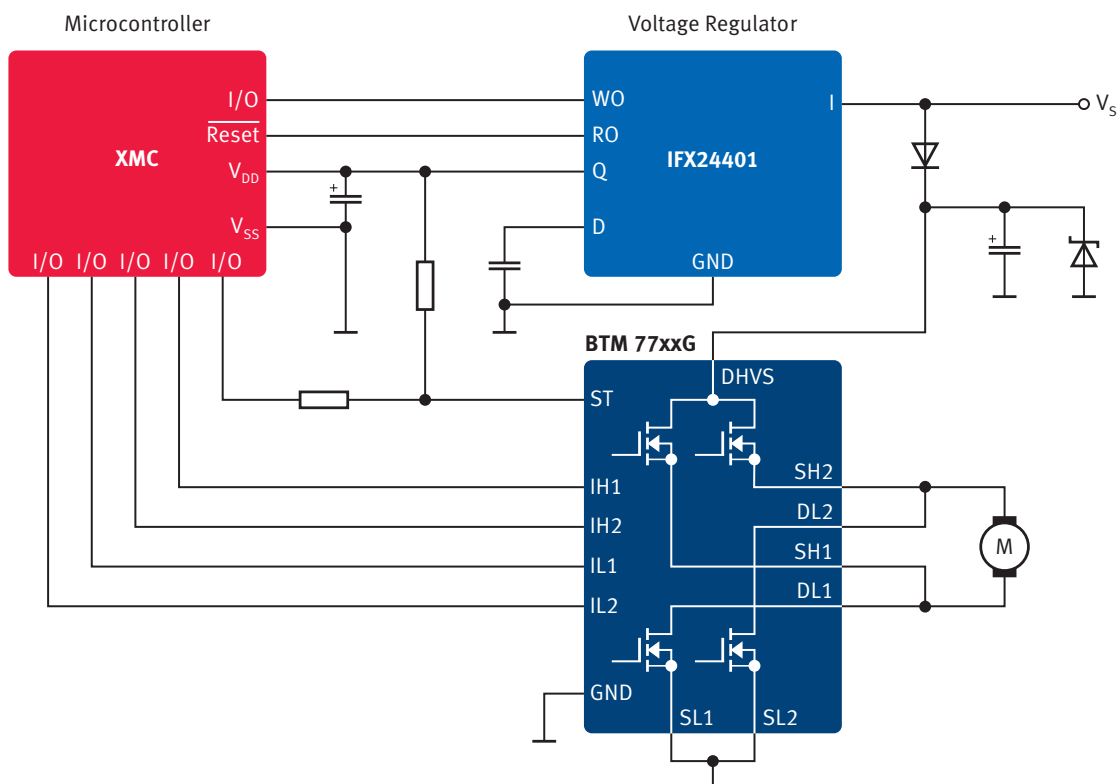

Trilith IC Product Overview

Product Type	Operating Range [V]	$R_{DS(on)}$ Path (typ) @25°C [mΩ]	$I_{D(lim)}$ (typ) [A]	I_q (typ) [μA]	Switch Freq. (typ) [kHz]	Diagnosis	Protection	Package
BTM7740G	4.8 ... 42.0	210	8.0	5	1	OT	OT, SC	PG-DSO-28
BTM7741G	4.8 ... 42.0	210	8.0	5	1	OT, OL	OT, SC	PG-DSO-28
BTM7700G	4.8 ... 42.0	190	9.5	5	1	OT	OT, SC	PG-DSO-28
BTM7750G	4.8 ... 42.0	115	12.0	5	1	OT	OT, SC	PG-DSO-28
BTM7750GP ¹⁾	4.8 ... 42.0	115	12.0	5	1	OT	OT, SC	PG-TO-263-15
BTM7751G	4.8 ... 42.0	115	14.0	5	1	OT, OL	OT, SC	PG-DSO-28
BTM7710GP ¹⁾	4.8 ... 42.0	110	15.0	5	1	OT	OT, SC	PG-TO-263-15
BTM7710G	4.8 ... 42.0	110	15.0	5	1	OT	OT, SC	PG-DSO-28
BTM7810K ¹⁾	5.0 ... 42.0	40	42.0	4	1	OT, OL	OT, SC	PG-TO-263-15
BTM7811K ¹⁾	5.0 ... 42.0	40	42.0	4	20	OT, OL	OT, SC	PG-TO-263-15
BTM7752G	5.5 ... 28.0	150	12.0	5	25	OV, OT, SC/OC, CS	OV, UV, OT, SC/OC	PG-DSO-36
BTM7755G	5.5 ... 28.0	150	12.0	5	1	OV, OT, SC/OC	OV, UV, OT, SC/OC	PG-DSO-36
BTM7742G	5.5 ... 28.0	250	12.0	5	25	OV, OT, OC, CS	OV, UV	PG-DSO-36
BTM7745G	5.5 ... 28.0	250	12.0	5	25	OV, OC, OT	OV, UV, OT, SC/OC	PG-DSO-36

1) AEC std. grade 3, $T_{j(max)} = 110^{\circ}\text{C}$

CS = Current Sense
 OL = Open-Load
 OV = Overvoltage
 UV = Undervoltage

OT = Overtemperature
 SC = Short-Circuit
 OC = Overcurrent

H-Bridge and 3-Phase Gate Driver ICs

Infineon’s focus on energy efficiency is translated into our Bridge Driver IC family. In the future, more and more applications will move from uncontrolled motors toward brushless DC motors. Our family of configurable, H-bridge and 3-phase gate driver ICs can be combined with powerful Infineon MOSFETs to provide the required power and efficiency these systems require.



Basic Features

- Strong output stage up to 1.5A
- Precise OpAmp for shunt current monitoring
- Operation down to 5.5V
- Duty cycle adjustable up to 100%
- Wide selection including integrated μ C supply

Diagnostic Features

- Undervoltage
- Short-circuit detection
- Overtemperature
- Overvoltage

Benefits

- Fast and precise OpAmp measurement improves energy efficiency
- Temperature measurement and additional diagnostic features enable robust design
- Cost reduction on system level using integrated μ C supply
- Wide input voltage up to 60V

Application Example for BLDC Motors

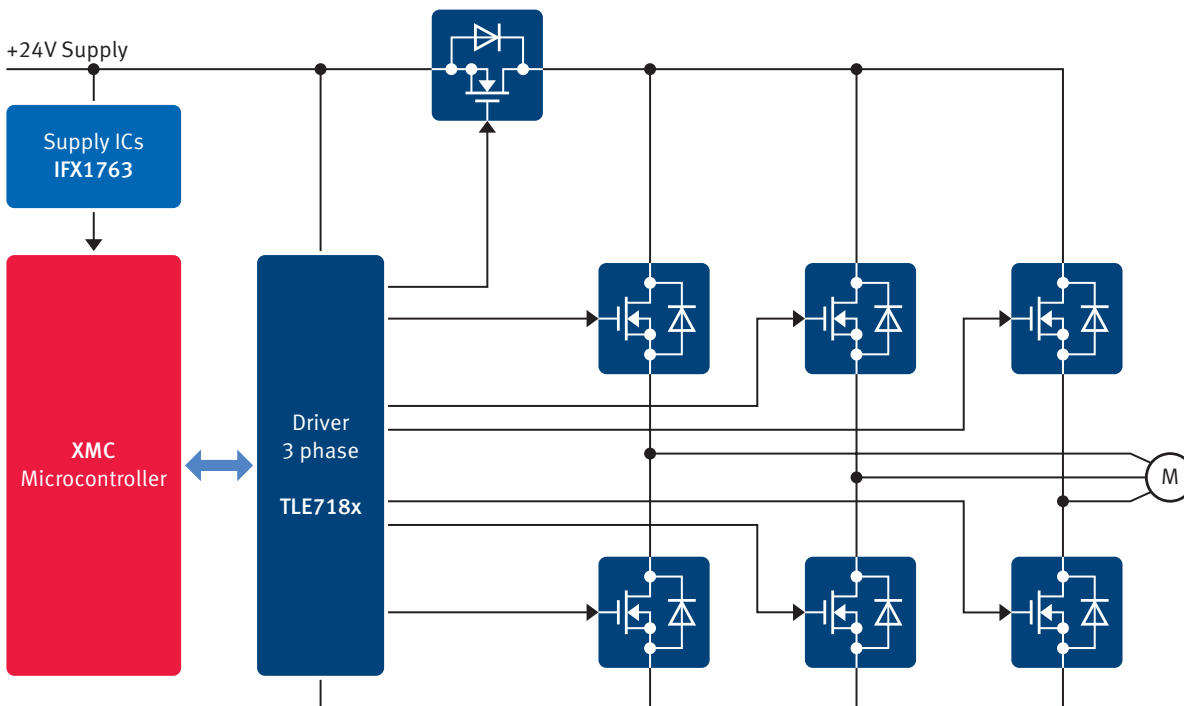

H-Bridge/Dual Half-Bridge Driver Family

Product Code	Operating Range [V]	OpAmp	PWM/DIR Input	Reverse Polarity Protection	Diagnosis	Package
TLE7181EM	7.0 ... 34.0	1	●	●	UV, OV, OC, SCD, OT	PG-SSOP-24
TLE7182EM	7.0 ... 34.0	1	–	●	UV, OV, OC, SCD, OT	PG-SSOP-24

3-Phase Bridge Driver IC

Product Code	Operating Range [V]	Drives Stage	D.C. Range @ 20kHz [%]	Number of Integrated OpAmps	Adjustable Dead Time	ProSIL Features	Diagnosis	Package
TLE7183F ²⁾	5.5 ... 28.0	1.5/1.5A	0 ... 100	1	●	–	UV, OV, OC, OCD	PG-VQFN-48
TLE7183QU ²⁾	5.5 ... 28.0	1.5/1.5A	0 ... 100	1	●	–	OT, UV, OV, OC, SCD	PG-VQFN-48
TLE7184F TLE7184F-3V ¹⁾	7.0 ... 32.0	13.5/9Ω	0 ... 95	1	●	–	UV, OV, OC, SCD, OT, VDD supervision	PG-VQFN-48
TLE7186F	7.0 ... 32.0	13.5/9Ω	0 ... 95	1	●	–	UV, OV, OC, SCD, OT, VDD supervision	PG-VQFN-48
TLE7185E	5.5 ... 32.0	13.5/9Ω	0 ... 95	0	●	–	UV, OV, SCD, OT	PG-DSO-36
TLE7188F	5.5 ... 28.0	1.5/1.5A	0 ... 100	3	–	–	UV, OV, OC, SCD, OT	PG-VQFN-48
TLE7189F	5.5 ... 28.0	1.5/1.5A	0 ... 100	3	–	●	UV, OV, SCD, OT, VDD supervision	PG-VQFN-48
TLE7189QK	5.5 ... 28.0	1.5/1.5A	0 ... 100	3	–	●	UV, OV, SCD, OT, VDD supervision	PG-LQFP-64
TLE9180-xxQx ³⁾	5.5 ... 60.0	1.5/1.5A	0 ... 100	3	●	●	UV, OV, SCD, OT, VDD supervision, ASIL features	PG-LQFP-64

- 1) System IC for fans and pumps with integrated LDO and PWM interface
 2) Offers flexible hard-coded short-circuit detection threshold (SCDx)
 3) Product under development

OV = Overvoltage
 OC = Overcurrent
 LO = Lockout

UV = Undervoltage
 SCD = Short-Circuit Detection
 OL = Open-Load
 OT = Overtemperature

Monolithic H-Bridges

Infinite offers a broad range of automotive-qualified H-bridges for industrial applications, from gardening equipment through printers and scanners to coffee machines. Originally designed for the extreme

environments of powertrain engine applications, the H-bridges can be used for all types of DC motor applications and feature state-of-the-art SmartPower™ technology.

Product Features

- Supply range¹⁾: 5–40V
- Output current¹⁾: 1–8.6A
- $R_{DS(on)}$ ¹⁾: 120–230mΩ (typ. 25°C per transistor)

Protection Features

- Diagnosis capability¹⁾
- Broad green package portfolio

1) depending on selected H-bridge

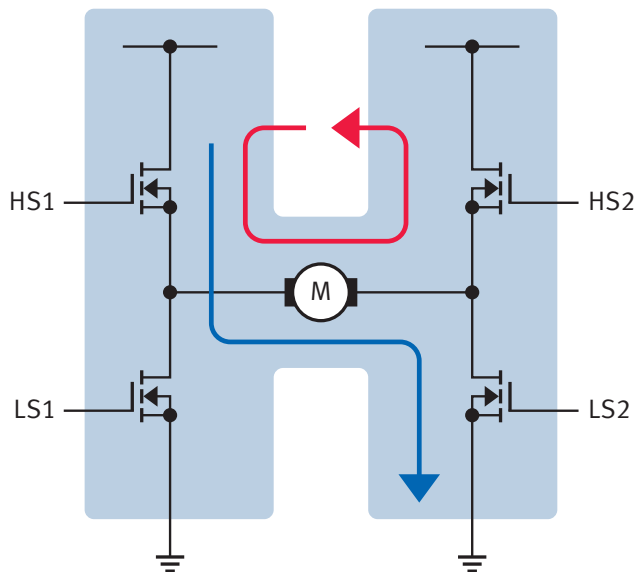

Product Overview

Device Name	Operation Range [V]	R_{max} @150°C [mΩ]	Min. Short-Circuit Detection GND [A]	Current Limit (min) [A]	Quiescent Current (max)	R_{TH} (max) [K/W]	f_{max} Switching [kHz]	Output Control	Status Flag	SPI	Open-Load Detection	18V I/O Tolerance	Package
TLE5205-2S/G	6.0 ... 40	500	6.0	6.0	10mA	3.0	not specified	IN1/IN2	•	–	In OFF	–	7 pin TO-220
TLE5206-2S/G	6.0 ... 40	500	6.0	6.0	10mA	3.0	not specified	IN1/IN2	•	•	–	–	7 pin TO-220
TLE6209R	5.2 ... 40	280	8.0	3.4/4.25/5.1/5.95	50µA	1.5	30	PWM/DIR	–	•	In ON	–	DG-DSO-20
TLE7209-2R/3R	5.0 ... 28	300	8.0	5.5	20mA	1.5	11	IN1/IN2	•	•	In OFF	•	DG-DSO-20
TL8209-2E/2SA	4.5 ... 28	250	2.5/5.0/7.5/9.5	1.0/3.3/5.5/7.7	20µA	4.6/1.6	11	IN1/IN2	•	•	In OFF	•	20 pin 300 mil/430 mil
TLE8209-4SA	4.5 ... 28	250	2.5/5.0/7.5/10.5	1.0/3.3/6.0/9.0	20µA	1.6	11	IN1/IN2	•	•	In OFF	•	20 pin 430 mil
TLE9201SG	4.5 ... 28	200	7.0	5	30µA	2.0	20	IN1/IN2/SPI	–	•	In ON/In OFF	–	12 pin 300 mil

Stepper Drivers – Cost-Efficient, Durable and Reliable

The TLE4726G and TCA3727G are designed to drive bipolar stepper motors, DC motors and other inductive loads that operate on a constant current. The TLE4726G and TCA3727G have integrated control logic and power output stages for two bipolar windings.



Key Features

- Full to half-step operation
- Protected bipolar power stages
- Implemented current control
- Error flag for diagnosis
- Overtemperature protection

Applications

- ATM
- Franking machines

Product Overview

Product Type	$I_{L(NOM)}$	$I_{L(lim)}$	I_q [μA]	$V_{S(op)}$	Step Operations	Protection	Diagnostic Interface	Highlights	Package
Current Controlled									
TCA3727G	2 x 0.75	2 x 1.5	200	5–50	Full to mini-step	OT	–	High operating voltage, low quiescent current with inhibit	PG-DSO-24/ PG-DIP-20
TLE4726G	2 x 0.75	2 x 1.5	200	5–50	Full to mini-step	OT	–		PG-DSO-24

OT = Overtemperature

IGBTs – For All Your Hard-Switching Requirements

Infineon's 600V and 1200V TRENCHSTOP™ IGBTs are the most efficient devices available on the market today. This makes them ideal for applications where efficiency is a key priority. The 600V and 1200V TRENCHSTOP™ IGBTs are typically used in UPS and solar inverters as well as in welding and industrial drives up to 10kW. The new 600V RC-D (Reverse Conducting for Drives) family is a cost-optimized, space-saving solution in DPAK or IPAK up to 15A. These devices are the perfect fit for the white goods segment up to 2kW, where cost and performance are key issues.



RC-Drives for 600V Hard-Switching Applications

Key Features

- Optimized for consumer markets
- Best in class $V_{ce(sat)}$ and V_f for outstanding efficiency at frequencies up to 20kHz
- Soft current turn-off waveforms

Key Benefits

- Outstanding space-saving capabilities
- Cost optimized
- Lowest power dissipation
- Low cooling and reduced EMI filtering requirements

RC-Drives Fast IGBTs for Comfort and Quietness

We have developed new versions of our RC-Drives IGBT devices to meet rising demand for IGBTs in the low-power motor drive consumer market.

Key Features

- Optimized E_{on} , E_{off} and Q_{rr} for up to 20% lower switching losses
- Smooth switching performance leading to low EMI levels
- Very tight parameter distribution
- Operating range of 4kHz to 30kHz

Key Benefits

- Best cost/performance for hard switching applications
- Space-saving of up to 60% on the PCB
- Excellent EMI behavior

At switching frequencies above 40kHz, the new 600V and 1200V third-generation, high-speed family (HS3) offers low switching losses and an excellent EMI performance.

Key Features and Benefits

- High efficiency thanks to lowest switching losses for switching frequencies up to 60kHz
- Soft-switching waveforms for excellent EMI behavior
- Low conduction losses thanks to low $V_{ce(sat)}$
- Optimized diode for target applications with low diode losses and fast recovery times
- RoHS compliance
- Positive $V_{ce(sat)}$ temperature coefficient for easy paralleling and no thermal runaway
- 10 μ s short-circuit rating

Product Overview

[A]	3	4	6	8	10	15	20	25	30	40	50	60	75
TO-247				■	■	■	■	■	■	■	■	■	■
TO-220 FullPAK			■		■		■						
TO-220		■	■		■	■	■		■				
D ² PAK			■		■								
I ² PAK		■											
DPAK	■	■	■		■	■							
I ² PAK		■	■		■	■							

- 600V TRENCHSTOP™
- 1200V TRENCHSTOP™
- 600V RC-Drives
- 1200V HS3 Family
- 600V HS3 Family
- 600V RC-Drives Fast

EiceDRIVER™ – Gate Driver IC for MOSFETs & IGBTs

Infineon has launched a new family of EiceDRIVER™ IGBT/MOSFET gate driver ICs for applications with blocking voltages from 600V up to 1200V. The new 6ED series is also available in a 200V version. Based on innovations such as thin-film, silicon-on-insulator technology (600V) and coreless transformer technology (1200V), these products increase reliability levels, reduce losses and improve performance.

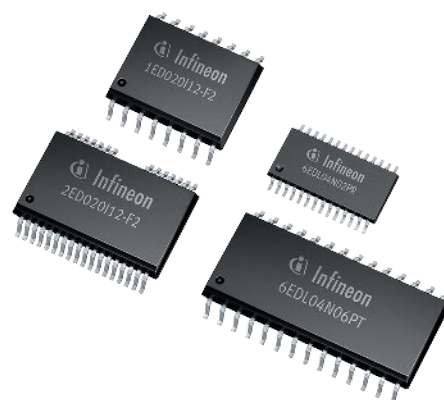

The 1ED020112-F2 (1200V) family member is a single-channel, isolated IGBT/MOSFET driver IC that provides bidirectional galvanic isolation as well as feedback and integrated protection features. The 1ED020112-B2 (1200V) also offers basic isolation at a maximum working voltage of 1420V. A special two-level turn-off feature is integrated in the 1ED020112-FT and 1ED020112-BT models.

The 2ED020112-F2 (1200V) is a dual-channel, isolated IGBT/MOSFET driver IC. It bundles the same functionality as two 1ED020112-F2 ICs in a single, compact package.

The 2ED020106-FI (600V) and 2ED020112-FI (1200V) half-bridge driver ICs include galvanic isolation on the high-side channel as well as customizable overcurrent protection.

The new 200V and 600V 6ED series comprises 3-phase gate driver ICs, which offer excellent robustness against negative transients down to -50V. Variants are available either with or without fully integrated bootstrap functionality, positive or negative logic, different undervoltage lockouts and overcurrent protection.

Application Example for 1200V 3-Phase Drives

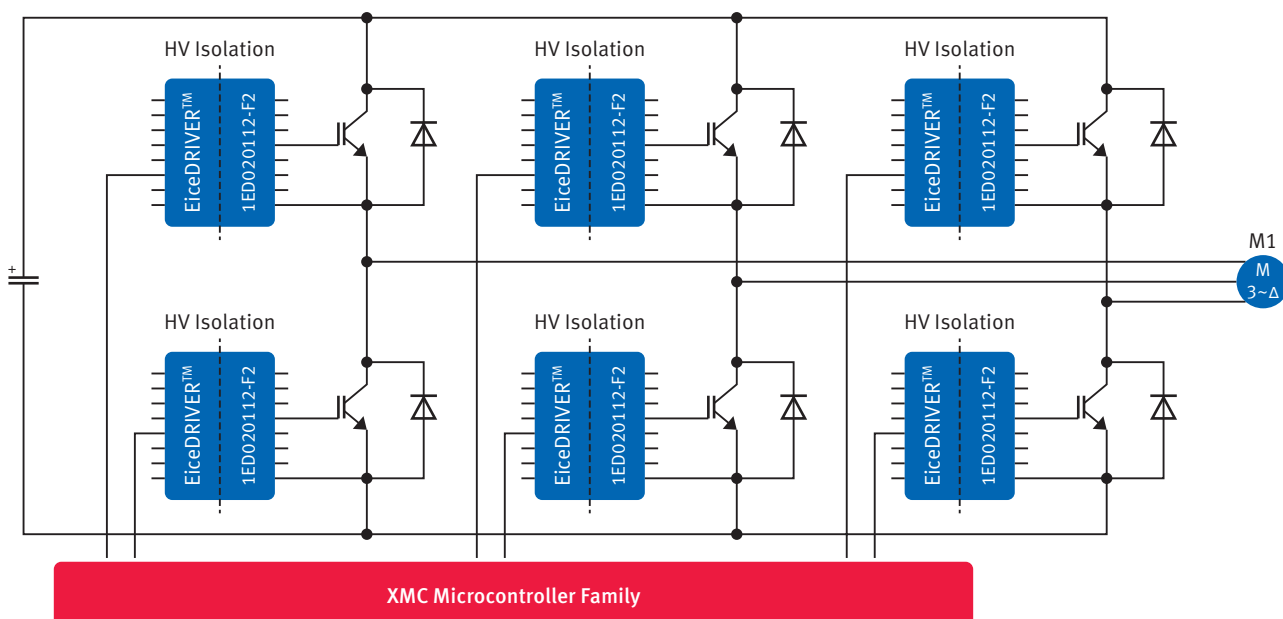

High-Power Modules

Variable-speed drive systems play a key role in enhancing energy efficiency. We can help to boost energy performance with our latest chip technologies and innovative module designs covering the power range from 0.5kW up to more than 1MW. Infineon offers a broad

portfolio of power modules for motor control drives: SmartPIM & SmartPACK, MIPAQ™, Easy, EconoPACK™2, 3 & 4, EconoPACK™+ D-series, PrimePACK™ & IHM-B and 62mm IGBT Modules.

SmartPIM and SmartPACK – Flexible Assembly Through Self-Acting PressFIT Technology

Infineon has expanded its PressFIT technology range to include the new SmartPIM and Smart-PACK housing concepts.

The new housing enables the module to be connected with the heat sink and the PCB in a single mounting process. The PressFIT pin is pressed into the PCB, the PCB is stabilized and the module is mounted on the surface of the heat sink in a single step. The whole mounting concept can be performed using an adapted screwdriver. No additional tools are required. This new technology is suited to all conventional electrical circuits. The housing accommodates current up to 75A.

This module family combines all the reliability of established PressFIT technology with a range of advanced features:

- Press-in process by simply tightening a single screw
- Flexible mounting
- The new module and mounting concept reduces process time
- Robust housing concept with decoupled DCB force
- Gas-tight contact, therefore immune to ambient atmosphere
- Decreased FIT rates for interconnections
- Reliable, cold-welded connection of module pins and PCB
- Can be mounted on both sides of standard PCBs

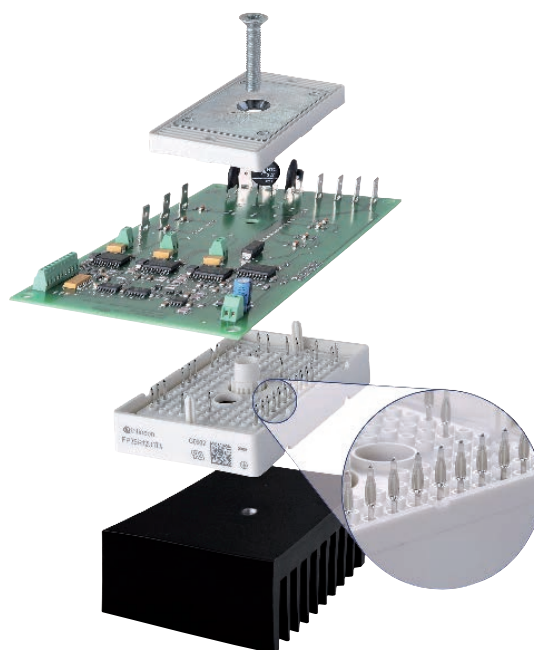

I_c [A]	1200V PIM	600V PIM	1200V SixPACK	600V SixPACK
75				
50				
35				
25				
15				
10				

MIPAQ™ serve – The Next Level of Extended Functionality and Integration

MIPAQ™ serve is a highly reliable IGBT module in sixpack configuration with integrated driver electronics and digital temperature measurement. The integrated driver provides several protection features as well as galvanic isolation using Infineon’s Coreless Transformer Technology. These integrated functionalities make MIPAQ™ serve a full plug-and-play solution for high-current drive applications.

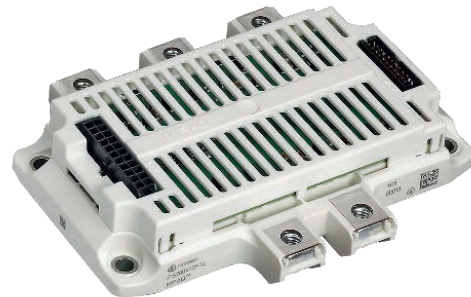

MIPAQ™ serve comes with the EconoPACK™ 4 package and the latest IGBT4 chip technology. It covers the 1200V range and manages currents of 100A, 150A and 200A. The supply voltages and logic signals are transferred through standardized connectors while the power connections are established with M6-sized screws.

Key Features

- Galvanically isolated EiceDRIVER™ using Infineon’s Coreless Transformer Technology
- Digital NTC sensing with galvanic isolation
- Delay deviations between all IGBT channels below 20ns
- Fully tested and assembled system

Key Benefits

- Short time-to-market of new drive solutions
- High efficiency since low dead times are feasible
- High reliability thanks to Coreless Transformer Technologies

MIPAQ™ serve Functional Diagram

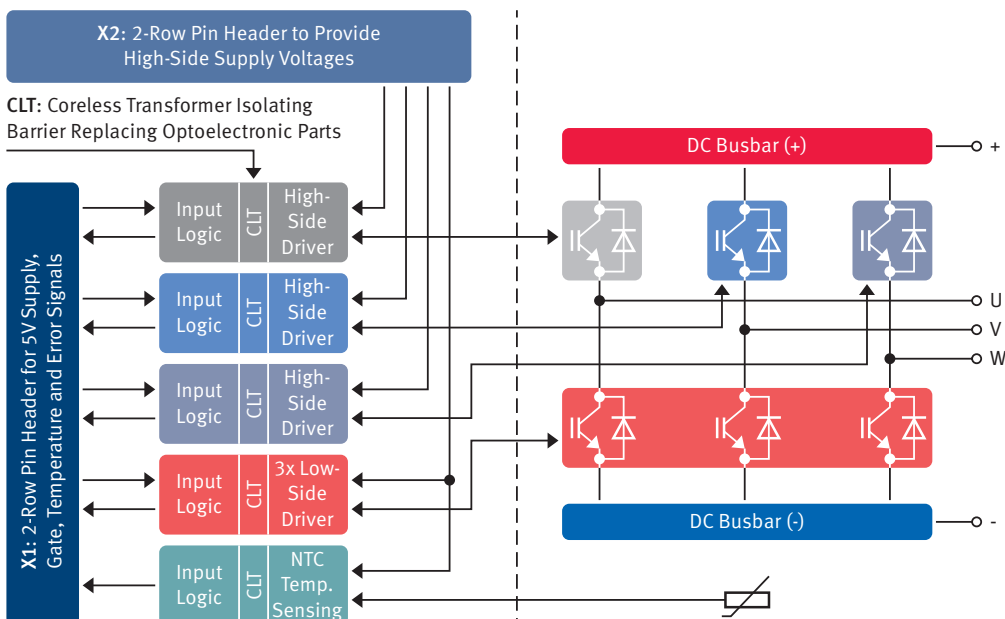

Easy Modules

The EasyPIM™/EasyPACK families were developed in order to ensure a cost-effective compact design as well as simplified and reliable mounting. Infineon therefore offers an optimized product generation for low and medium-power industrial drives.

With its EasyPIM™, EasyPACK, and EasyDUAL configurations, the EASY family covers a full product scope in the power range from IC 6A up to 200A at 600V/650V/1200V. The modules are without base plates and include the latest IGBT4 technology. The screw clamp provides a new, fast, reliable and low-cost mounting concept.

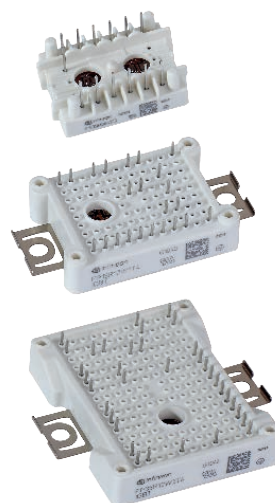

This series has been extended to include the Easy1B and Easy2B size for more flexibility with a reduced height from 17mm to 12mm and injected mounting screw clamps.

The new Easy 3-level modules provide a complete phase leg from 30A up to 150A in 600V/650V. The solution offers a significant advantage for designing highly efficient UPS and solar inverters. New modules for photovoltaic string and multi-string inverters are also available.

Key Features

- PressFIT and solder pins available
- Compact module concept
- Low thermal resistance
- High power density
- Mechanical robustness
- Integrated temperature sensor available
- Low stray inductance module design
- EasyPIM™ 2B up to 35A
- EasyPIM™ 1B up to 15A

Easy 1B & 2B Product Portfolio (600V & 1200V)

I _C [A]	Power Integrated Module		Sixpack	
	600V	1200V	600V	1200V
10	FP10R06W1E3 FP10R06W1E3_B11	FP10R12W1T4 FP10R12W1T4_B11	–	–
15	FP15R06W1E3 FP15R06W1E3_B11	FP15R12W1T4 FP15R12W1T4_B11 FP15R12W2T4	–	–
20	FP20R06W1E3 FP20R06W1E3_B11	FP25R12W2T4 FP25R12W2T4_B11	FS20R06W1E3 FS20R06W1E3_B11	FS25R12W1T4 FS25R12W1T4_B11
35	FP30R06W1E3 FP30R06W1E3_B11	FP35R12W2T4 FP35R12W2T4_B11	FS30R06W1E3 FS30R06W1E3_B11	FS35R12W1T4 FS35R12W1T4_B11
50	FP50R06W2E3 FP50R06W2E3_B11	–	FS50R06W1E3 FS50R06W1E3_B11	FS50R12W2T4 FS50R12W2T4_B11
75	–	–	–	FS75R12W2T4 FS75R12W2T4_B11

W1 = Easy1B
W2 = Easy2B

B11 = PressFIT terminals

EconoPACK™ 2 and EconoPACK™ 3 Modules

The EconoPIM™/EconoPACK™ families were developed to facilitate a cost-effective compact design as well as simplified and reliable mounting. Infineon therefore offers an optimized product generation for low and medium-power industrial drives.



The Econo family extends the power range from 15A up to 200A nominal current at 600V/650V/1200V/1700V. The well-known EconoPIM™ and EconoPACK™ series are the available configurations. The Econo housing features a copper base plate for optimized heat spread and includes a thermistor (NTC). The Econo modules are available with solderable pins or with PressFIT pins. For ease of design, the optimized IGBT4 with 10µs short-circuit robustness is available in the same mechanical design serving the voltage classes 650V, 1200V and 1700V.

Key Features

- PressFIT and solder pins available
- High power density
- Optimized heat spreading due to copper base plate
- Integrated temperature sensor available
- Low stray inductance module design
- Rugged design
- EconoPIM™ 3 up to 100A
- EconoPACK™ 3 up to 200A
- EconoPIM™ 2 up to 50A
- EconoPACK™ 2 up to 100A

Econo IGBT4 Product Portfolio for New Designs (650V, 1200V & 1700V)

I _C [A]	Power Integrated Module			Sixpack		
	650V	1200 V	1700V	650V	1200V	1700V
25	–	FP25R12KT4 FP25R12KT4_B11	–	–	–	–
35	–	FP35R12KT4 FP35R12KT4_B11	–	–	FS35R12KT4_B11	–
50	FP50R07N2E4 FP50R07N2E4_B11	FP50R12KT4 FP50R12KT4_B11	–	FS50R07N2E4 FS50R07N2E4_B11	FS50R12KT4_B15 FS50R12KT4_B11	–
75	FP75R07N2E4 FP75R07N2E4_B11	FP75R12KT4 FP75R12KT4_B11	FP75R17N3E4	FS75R07N2E4 FS75R07N2E4_B11	FS75R12KT4_B15 FS75R12KT4_B11	–
100	FP100R07N3E4 FP100R07N3E4_B11	FP100R12KT4 FP100R12KT4_B11	–	FS100R07N2E4 FS100R07N2E4_B11 FS100R07N3E4 FS100R07N3E4_B11	FS100R12KT4 FS100R12KT4_B11 FS100R12KT4G FS100R12KT4G_B11	FS100R17N3E4 FS100R17N3E4_B11
150	FP150R07N3E4 FP150R07N3E4_B11	–	–	FS150R07N3E4 FS150R07N3E4_B11	FS150R12KT4 FS150R12KT4_B11	FS150R17N3E4 FS150R17N3E4_B11
200	–	–	–	FS200R07N3E4R FS200R07N3E4R_B11	FS200R12KT4R FS200R12KT4R_B11	–

N2 = Econo2
N3 = Econo3
B11 = PressFIT terminals

..._B15 module alternative mechanically compatible with an IGBT3 module

62mm IGBT Modules

Well-known Product Family for Successful Inverter Designs

Flexibility, an optimal electrical performance and the highest reliability: These are the keywords for a successful inverter layout. Our well-known 62mm modules are the right choice for your design. The Infineon Technologies AG presents its product family of half-bridges and single switches with state-of-the-art IGBT4 chip technology at 650V/1200V/1700V.

The 62mm product line offers the current range from 300A to 400A at 650V, i.e.:

- 62mm modules in half-bridge configuration up to 400A/650V (E4 chips)

The 62mm product line also offers the current range from 150A up to 600A at 1700V, i.e.:

- 62mm modules in half-bridge configuration up to 300A/1700V (E4 chips)
- 62mm single switches up to 600A/1700V (E4 chips)

Customer benefits: With its enlarged product portfolio, the well-known 34 and 62mm module family offers more flexibility and highest reliability to the user and efficiently supports the realization of modern inverter concepts for all kinds of applications.



Main Features

- Superior solution for frequency-controlled inverter drives
- UL/CSA certification with UL1557 E83336
- Operating temperature up to 150°C
- Optimized switching characteristics
 - Softness
 - Reduced switching losses
- Existing packages with high-current capability
- RoHS compliant

Applications

- Variable speed drives
- Stand-alone drives
- Active front-end
- Power supplies
- Uninterruptible power supplies
- Resonant converters
- Central solar inverters
- Welding
- Inductive heating

62mm IGBT Modules

Product Overview IGBT4

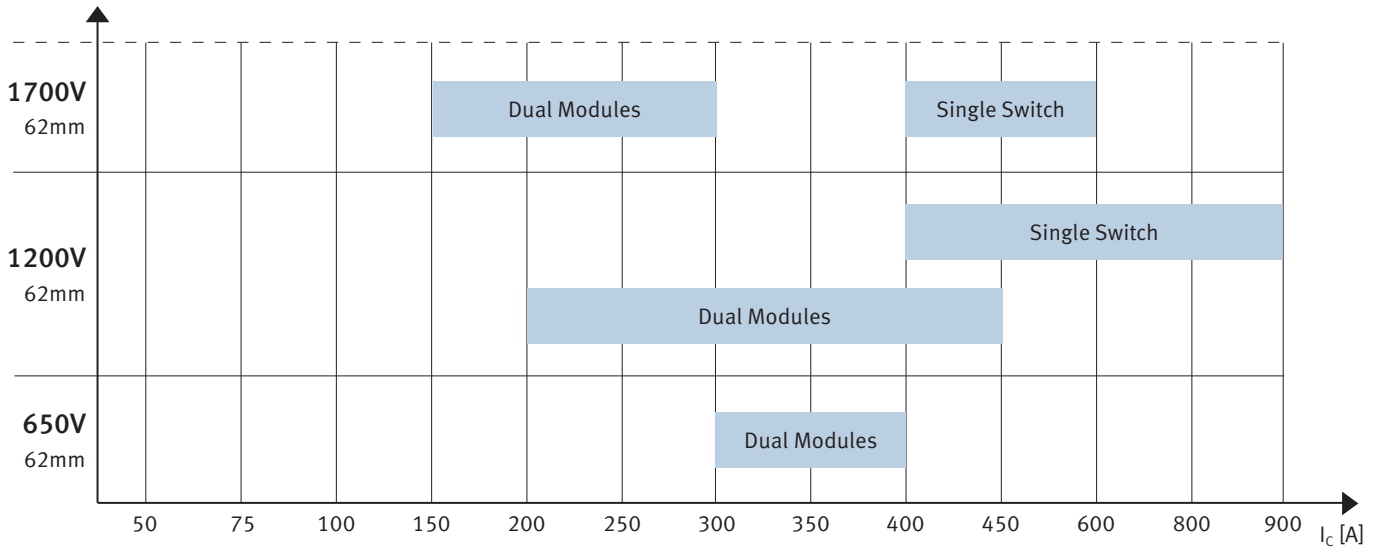

Available Module Configurations		
Infinion Shortcut	Description	Circuit
FF	Dual	
FZ	Single Switch	

Available Module Configurations		
Infinion Shortcut	Description	Circuit
FD; DF	Chopper	

EconoPACK™ 4 – The New Standard for Compact Inverter Designs

The EconoPACK™ 4 is a new member in our highly-rated Econo product family. The new EconoPACK™ 4 IGBT modules feature screw power terminals with excellent electric connections, separate DC and AC links and PressFIT control pins for solderless inverter assembly. All of which makes them the ideal choice for industrial applications.



- Superb reliability, conductivity and efficiency
- Low stray inductance design
- IGBT4 650V and IGBT4 1200V and 1700V chip technologies
- Screw power terminals and PressFIT control pins
- Robust design

3-Phase, Full-Bridge (SixPACK)

Configuration:

650V/1200V: 100A, 150A, 200A

1700V: 100A, 150A

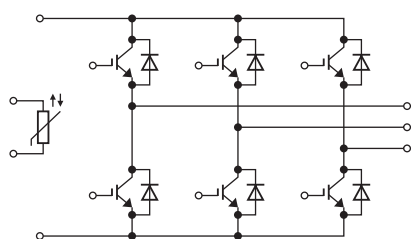

3-Level, 1-Phase Configuration:

650V: 200A, 300A

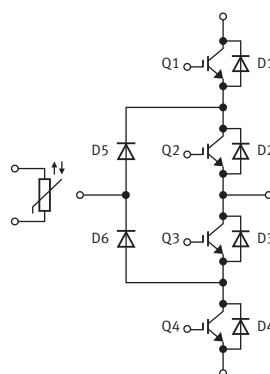

3*Chopper Configurations:

1200V: 200A

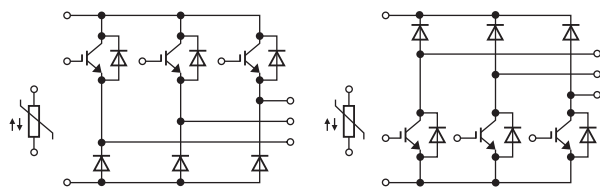

3-Level, 1-Phase NPC2 Configuration:

1200V/650V: 300A, 400A

650V/650V: 400A

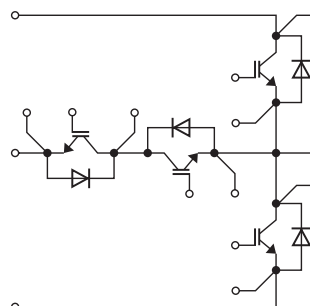

EconoDUAL™ 3

EconoDUAL™ 3650V/1200V/1700V 600A – Best in Class

The FF600R17ME4/_B11 is the new flagship product in Infineon's well-established EconoDUAL™ 3 series. It was developed with a clear focus on maximum possible power density within a given footprint. Thanks to the use of copper bonding technology as well as an improved DCB, the output power can be increased by more than 30% compared to the 450A version.



The FF600R07ME4_B11 is a new member of Infineon's EconoDUAL™3 family. With improved 650V IGBT4 chips, it offers a superior switching performance together with an excellent short-circuit withstand time of 10us. This module also uses copper wire bonding to reduce internal lead resistance.

Together with the FF600R12ME4/_B11, Infineon is the first supplier of a 600A current-rated module for all voltage classes in the EconoDUAL™ 3 package. With excellent mechanical robustness, power cycling capability as well as the option of PressFIT pins, Infineon offers a reliable, cost-effective solution for applications such as wind turbines, drives, hybrid vehicles etc.

Key Features

- New advanced assembly technologies
- Superb thermal performance to enable full power utilization
- Plug&play upgrade of existing inverter designs
- PressFIT and solder pin versions
- Best-in-class current rating:
600V/1200V/1700V 600A with Infineon's IGBT4

Product Overview

1700V Dual	1200V Dual	600V Dual
FF600R17ME4	FF600R12ME4	FF600R07ME4_B11
FF600R17ME4_B11	FF600R12ME4_B11	–

EconoPACK™+ D-Series – Fit for the Future

EconoPACK™+ D-series – IGBT modules for increased requirements

Increasing efficiency while simultaneously boosting the lifetime and durability of a state-of-the-art frequency converter is one of the main challenges in power electronics.

To meet these high standards well into the future, we developed the new EconoPACK™+ D-series. The new EconoPACK™+ D-series is based on the EconoPACK™+ platform.

The D-series is focused on a rugged and robust module design via injection molded control and power terminals and ultrasonic welded power terminals.

The innovative EconoPACK™+ D-series uses PressFIT auxiliary terminals to ensure reliable and solderless press-in contacts. The PressFIT contacts also provide the flexibility for a soldering process, if required.

In combination with cutting-edge IGBT technologies, the EconoPACK™+ D-series is equipped to fulfill future requirements.

Key Features and Benefits

- Lead-free mounting to meet RoHS
- Easy solderless mounting concept saves production cost and time
- High reliability by decreasing FIT rate compared to spring or solder PCB mounting
- Approved technology, already used in the automotive sector
- Focus on robust design
- Injection molded terminals
- Ultrasonic welded power terminals



Product Overview

1700V Sixpack	1200V Sixpack
FS225R17OE4	FS225R12OE4
FS300R17OE4	FS300R12OE4
FS450R17OE4	FS450R12OE4
FS500R17OE4D	FS500R17OE4D

PrimePACK™ and IHM-B – Revolutionizing Current and Future Designs

The PrimePACK™ IGBT modules with internal NTC offer a specially optimized concept for integration in modern converters. The most important benefits include improved thermal and electrical properties, low stray inductance and high robustness.

The excellently positioned DC terminal screw connections on PrimePACK™ offer high flexibility for a parallel design to realize a broad power range of inverters and further advance to low inductive inverter design.



The well-known IHM (IGBT High-Power Module) works with supreme reliability at any temperature from -40 to +150°C and is robust against harsh environments. Continuously improved thermal and electrical performance makes IHM the preferred choice for a powerful, compact and modular converter design. More than 2 million IHMs in various applications around the globe are testament to their high level of market acceptance.

The newly introduced IHM-B enhances the portfolio further with its lower switching losses and higher power cycling capability. Furthermore, its reduced stray inductance influence and optimized terminal connections make the module easy to control and safe to use.

Both product families feature the very latest silicon and key production technologies such as:

- Ultrasonically welded power and auxiliary terminals
- IGBT4 for 1200V and 1700V
- IGBT3 for 3.3kV and 4.5kV

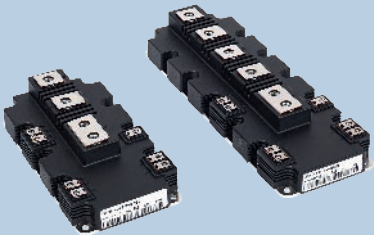
Infineon Technologies' years of experience and continuous innovations – together with the most recent optimized chip generations for high power density – always ensure optimal solutions for converters in motor control and drives applications.

PrimePACK™	IHM-B	IHM-B
1200V & 1700V	1200V & 1700V	3.3kV & 4.5kV
 <p data-bbox="240 1798 411 1827">450 – 1400A</p>	 <p data-bbox="708 1798 879 1827">800 – 3600A</p>	 <p data-bbox="1176 1798 1347 1827">500 – 1500A</p>
Half-Bridges Chopper	Single Switches Half-Bridges Chopper Diode	Single switches Chopper Diode

Hall IC Switches

The Infineon TLE4968-1 and TLE4961-1 bipolar Hall-effect switches enable exact rotor position detection in BLDC motor commutation. These automotive-qualified sensors feature precise magnetic switching thresholds of $\pm 1\text{mT}$ (TLE4968-1) and $\pm 2\text{mT}$ (TLE4961-1) which facilitate motors with smooth torque. With an operating voltage of 3V to 32V and a typical current consumption of just 1.6mA, the sensors are ideally suited for energy-efficient system requirements. Available in a small package, very compact BLDC systems can be realized.



Common Sensor Features

- Operation from an unregulated power supply
- 3V to 32V extended high operating supply voltage
- Overvoltage capability up to 42V (no additional, external resistor necessary)
- Reverse battery protection (-18V)
- High sensitivity and high stability of the magnetic switching points
- High resistance to mechanical stress due to active error compensation
- Superior temperature stability
- Extended ESD performance ($\pm 7\text{kV}$ HBM)
- Low jitter (typ. $0.3\mu\text{s}$ for a square input signal)
- Automotive qualified
- Output overcurrent & overtemperature protection
- Available in SMD packages SC59 and SOT23 and leaded package PG-SSO-3

Block Diagram TLE496x

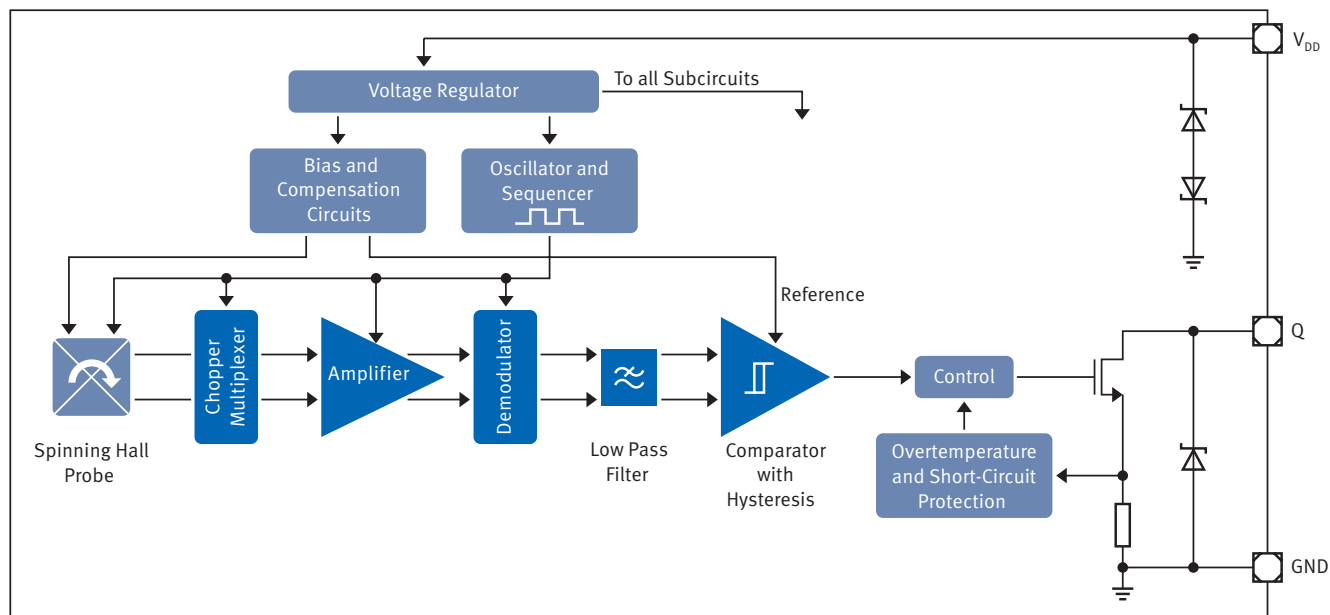

Product Overview

Product Type	Package	Type	B_{OP} [mT]	B_{RP} [mT]
TLE4968-1K/M/L	PG-SC59/PG-SOT23/PG-SSO-3	Bipolar Switch	1.0	-1.0
TLE4961-1K/M/L	PG-SC59/PG-SOT23/PG-SSO-3	Latch	2.0	-2.0
TLE4961-2M	PG-SOT23	Latch	5.0	-5.0
TLE4961-3K/M/L	PG-SC59/PG-SOT23/PG-SSO-3	Latch	7.5	-7.5
TLE4961-4M	PG-SOT23	Latch	10.0	-10.0
TLE4961-5K/M	PG-SC59/PG-SOT23	Latch	15.0	-15.0

GMR-Based Magnetic Angle Sensors

Infineon's magnetic angle sensing principle is based on proven, automotive-qualified integrated Giant Magneto Resistive (iGMR) technology. iGMR technology combines magneto resistive sensing elements and integrated circuits into one chip. iGMR technology can determine the absolute orientation of a magnetic field between 0° and 360°. The product portfolio covers a wide range of integrated signal processing and interfaces. Infineon iGMR sensors combine high angular accuracy and resolution with fast signal processing and short delay times, making them ideal for rotor position sensing in electrical drives.

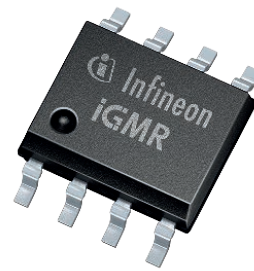

Key Features

- Integrated GMR (iGMR) technology
- 0–360° angle measurement with sine and cosine bridge
- Supply voltage 3.3 or 5.0V
- -40°C to +150°C
- On-chip signal processing with angle calculation
- Digital and analog interfaces
- Automotive qualified

Application Example

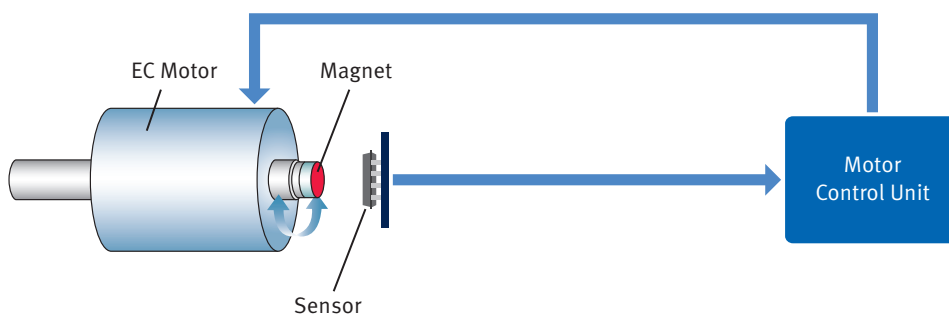

Product Overview

Product Type	Packages	Halogen-Free	Package	Interface	Application
TLE5009 E1000	PG-DSO-8	Available	SMD	Analog	Angle iGMR
TLE5009 E1010	PG-DSO-8	Available	SMD	Analog	Angle iGMR
TLE5009 E2000	PG-DSO-8	Available	SMD	Analog	Angle iGMR
TLE5009 E2010	PG-DSO-8	Available	SMD	Analog	Angle iGMR
TLE5011	PG-DSO-8	Available	SMD	SPI	Angle iGMR
TLE5012B E1000	PG-DSO-8	Available	SMD	SPI, IIF	Angle iGMR
TLE5012B E3005	PG-DSO-8	Available	SMD	SPI, HSM	Angle iGMR
TLE5012B E5000	PG-DSO-8	Available	SMD	SPI, PWM	Angle iGMR
TLE5012B E9000	PG-DSO-8	Available	SMD	SPI, SPC	Angle iGMR

TLI4970 – Current Sensor Family

Miniature Magnetic Digital Current Sensor $\pm 25/50\text{A}$, up to $\pm 1\%$, 80kSPS, Digital SPI Output

The TLI4970 is a high-precision current sensor based on Infineon's well-established Hall technology. The coreless concept allows significant miniaturization compared to existing solutions. It is a fully digital, easy-to-use solution. There is no need for any external calibration and additional parts (such as A/D converters, OpAmps and reference voltage) thereby significantly reducing the overall implementation effort, PCB space and cost.



Product Highlights

- Fully calibrated digital output
- On-chip temperature and stress compensation
- Programmable low-pass filter for current measurement (up to 18kHz)
- Fast and configurable overcurrent detector with a typical response time of 1.8 μs
- Inherent magnetic stray field rejection
- Small package size and weight in a 7x7mm SMD package

Block Diagram TLI4970

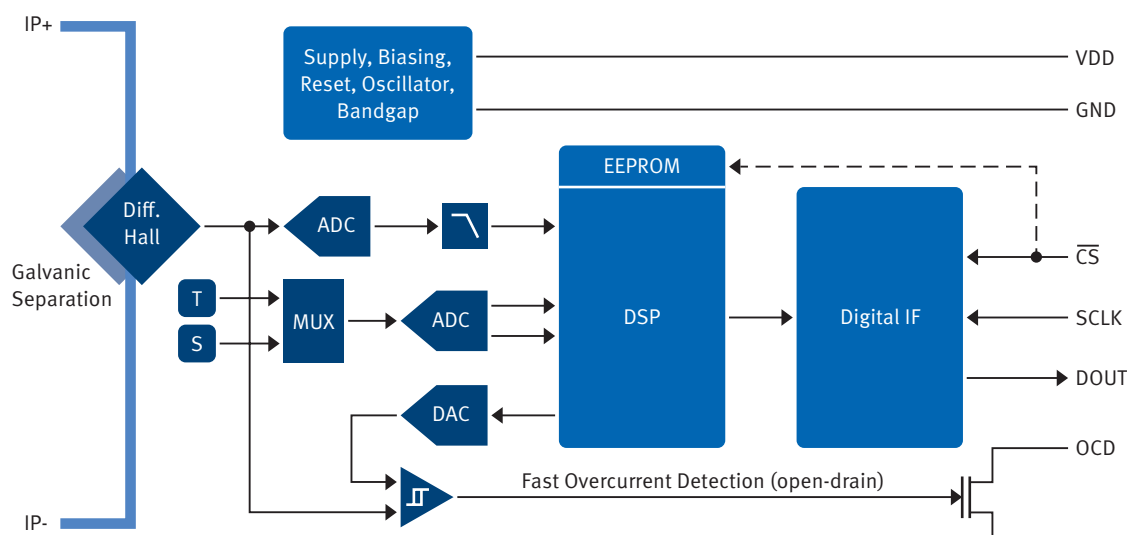

Product Summary

Product Name	Description	Primary Current Range	Max. Accuracy Error ¹⁾	Order Code
TLI4970-D050T4	Qualified according to industrial standards: For use in industrial and consumer applications	50A	1.0%	SP000917088
TU4970-D050T5		50A	3.5%	Upcoming
TLI4970-D025T5		25A	3.5%	Upcoming
TLE4970-D050T4	Qualified according AEC for automotive applications	50A	1.0%	On request

1) Accuracy error includes temperature and lifetime drifts

Ask Infineon. Get connected with the answers.

Infineon offers its toll-free 0800/4001 service hotline as one central number, available 24/7 in English, Mandarin and German.

Our global connection service goes way beyond standard switchboard services by offering qualified support on the phone. Call us!





- Germany 0800 951 951 951 (German/English)
- China, mainland 4001 200 951 (Mandarin/English)
- India 000 800 4402 951 (English)
- USA 1-866 951 9519 (English/German)
- Other countries 00* 800 951 951 951 (English/German)
- Direct access +49 89 234-0 (interconnection fee, German/English)

* Please note: Some countries may require you to dial a code other than "00" to access this international number, please visit www.infineon.com/service for your country!

Where to Buy

Infineon Distribution Partners and Sales Offices:
www.infineon.com/WhereToBuy

Stay connected

-  www.facebook.com/infineon
-  www.google.com/+infineon
-  www.twitter.com/infineon
-  www.infineon.com/linkedin
-  www.infineon.com/xing
-  www.youtube.com/infineon

Mobile Product Catalog

Mobile app for iOS and Android.



Infineon Technologies – innovative semiconductor solutions for energy efficiency, mobility and security.

Published by
Infineon Technologies AG
85579 Neubiberg, Germany

© 2014 Infineon Technologies AG.
All Rights Reserved.

Visit us:
www.infineon.com

Order Number: B158-H9357-G3-X-7600
Date: 03 / 2014

Attention please!

The information given in this document shall in no event be regarded as a guarantee of conditions or characteristics ("Beschaffenheitsgarantie"). With respect to any examples or hints given herein, any typical values stated herein and/or any information regarding the application of the device, Infineon Technologies hereby disclaims any and all warranties and liabilities of any kind, including without limitation warranties of non-infringement of intellectual property rights of any third party.

Information

For further information on technology, delivery terms and conditions and prices please contact your nearest Infineon Technologies Office (www.infineon.com).

Warnings

Due to technical requirements components may contain dangerous substances. For information on the types in question please contact your nearest Infineon Technologies Office. Infineon Technologies Components may only be used in life-support devices or systems with the express written approval of Infineon Technologies, if a failure of such components can reasonably be expected to cause the failure of that life-support device or system, or to affect the safety or effectiveness of that device or system. Life support devices or systems are intended to be implanted in the human body, or to support and/or maintain and sustain and/or protect human life. If they fail, it is reasonable to assume that the health of the user or other persons may be endangered.