



62196-2—
2013

2

(62196-2:2011
**Plugs, socket-outlets, vehicle connectors and vehicle inlets -
Conductive charging of electric vehicles - Part 2:
Dimensional compatibility and interchangeability requirements
for a.c. pin and contact-tube accessories
(IDT)**



2014

62196-2—2013

1 « » (« 4 ») « -
 2 056 « »
 3 08 8 2013 . Ns 1402-
 4 62196-2:2011 « ,
 2.

» (IEC 62(96-2:2011 «Plugs, socket-outlets, vehicle connectors and vehicle inlets - Conductive charging of electric vehicles - Part 2: Dimensional compatibility and interchangeability requirements for a.c. pin and contact-tube accessories».

5 8

1) - * 1.0—2012 (8).
 ». ()
 « ».

(gost.ru)

1	1
2	1
3	2
4	2
5	2
6	2
7	3
8	4
9	4
10	5
11	5
12	5
13	5
14	5
15	5
16	5
17	5
18	5
19	5
20	6
21	6
22	6
23	6
24	6
25	6
26	6
27	7
28	7
29	7
30	7
31	7
32	7
33	7
101	7
102	8
2-1.....	9
2-11.....	18
2-111.....	33
()	
().....	49

62196-2—2013

62196-1.
62196-1.
: « » « 62196-1. »,
1. ,
62196-1. 1. ,
101. , 62196-1, ,
• 1: , :
• 2: . -
• 3: / ()
).

Plugs, socket-outlets, vehicle connectors and vehicle inlets. Conductive charging of electric vehicles. Part 2.
Dimensional compatibility and interchangeability requirements for a.c. pin and contact-tube accessories

— 2014—09—01

1

(-), 50-60 () 63 500
70

62196-1,
61851-12010.
(EV) (PHEV).

1 -

61851-12010,

() (

30 * 50 ° .

2-

1. 2 3.

3.

62196-1.

2

62196-1
60068-2-14

N: Change of temperature)

(IEC 60068-2-14 Environmental testing • Part 2-14: Tests • Test N:

62196-2—2013

3

62196-1.

4

62196-1

1. 2. 3.
3.

5

62196-1

5.1

0-30 ():
200 - 250 6
380 - 480

5.2

2 ()

13

16 -

20 -

30 - 32 -

60 - 63 -

70

125 %

6

62196-1

6.1

- 70

63

6.2

6.3

6.4

6.5

7

101.

1.2 3

62196*2—2013

- 250 . 32 ;
 >250 . 13 20 . 32 . 63 . 70 ;
 > 360 - 480 . 13 20 . 32 . 63 3 :
 >250 . 16 32 :
 > 380 > 480 . 32 . 63 . 3 :
 >250 . 16 32 ;
 > 380 > 480 , 32 . 63 .

101-

1

		°
1	250 32 °	L1 (1)
2	250 32	L2 (2) / N ()
3		()
4	30 2	()
5	30 2	CS ()
* 81 / 125 % ° 4 5		

102 -

2 3

"	U _н		I _н		
	2	3	2'	3	
1	480	63	70	63	L1 (1) ⁰¹
2	480	63		1»	L2 (2)
3	480	63			L3 (3)
4	480	63	70	63	N () ^{01*}
5					()
6	30		2		()
7	30		2		CS () ⁰¹

* 125 %

8 1 4.

w 2- 1 2-IIIb.

* 2* .

11 L2 (2).

6.6
6.101

61851*1:2010.

7

62196*1

7.4

62196-2—2013

1 3 32 :
2 63 70

-
-
3 63 .

7.5 :
6

7.101 :
- 1;
- 2;
- 3.

8

62196-1.

9

9.1 62196-1 :
:

103:

1: 250 6. 32 :
- 2-;
- 2-1 .

2-1 2-1
60 .

2: 480 . 63 70 :
2-11. . lib. lie, Hd. . . llg. llh.

3: 250 . 16 , - :
- 2- ;
- 250 . 32 , - :
- 2- ;
- 480 . 63 , - :
- 2- ;

2-llld.

103 -

1	2-1		250	32	1
2	2-11		480	70	1
				63	3
3	2-111		250	16	1
			250	32	1
			480	63	3

10

62196-1 :
10.101 : 3

11

62196-1 :

12

62196-1.

13

62196-1.

14

62196-1 2 3: 1.
2-likJ 2-II

15

62196-1.

16

62196-1.

17

62196-1.

18

62196-1.

19

62196-1.

62196-2—2013

20

62196-1.

21

62196-1.

22

62196-1.

23

62196-1.

24

62196-1

24.1

:

:

25

62196-1.

26

62196-1

:

26.101

:

26.102

26.103 26.104.

-
-

:

2 62196-1:

26.103

60068-2-14

-
-
-

- Nb;

- 30° ;
-100° ;
-3 / :

- -1 ;
- -5.
- 26.104 20 1 .
- 27 ,
- 62196-1.
- 28 ,
- 62196-1.
- 29 ,
- 62196-1.
- 30
- 62196-1.
- 31
- 62196-1.
- 32 ()
- 62196-1.
- 33
- 62196-1 :
- 33.3 .
- 33.4 .
- 101
- 101.1
- 101.2
- 101.3

62196-2—2013

62196-1 (28).

101.4

101.4.1

101.4.2 - 10.4.4.

101.4.2

101.4.3

•

(,),

:

101.4.4

•

•

102

2.

(R₁).

61851-1:2010 (.5

«

»).

62196*2—2013

2-1

1

250

32

1. 2-1 32 250 .
(1 61651-1 (.2
61851-1:2010 (2()) 58.
2-la

P 62196-2—2013

2-1 (1)

250 32

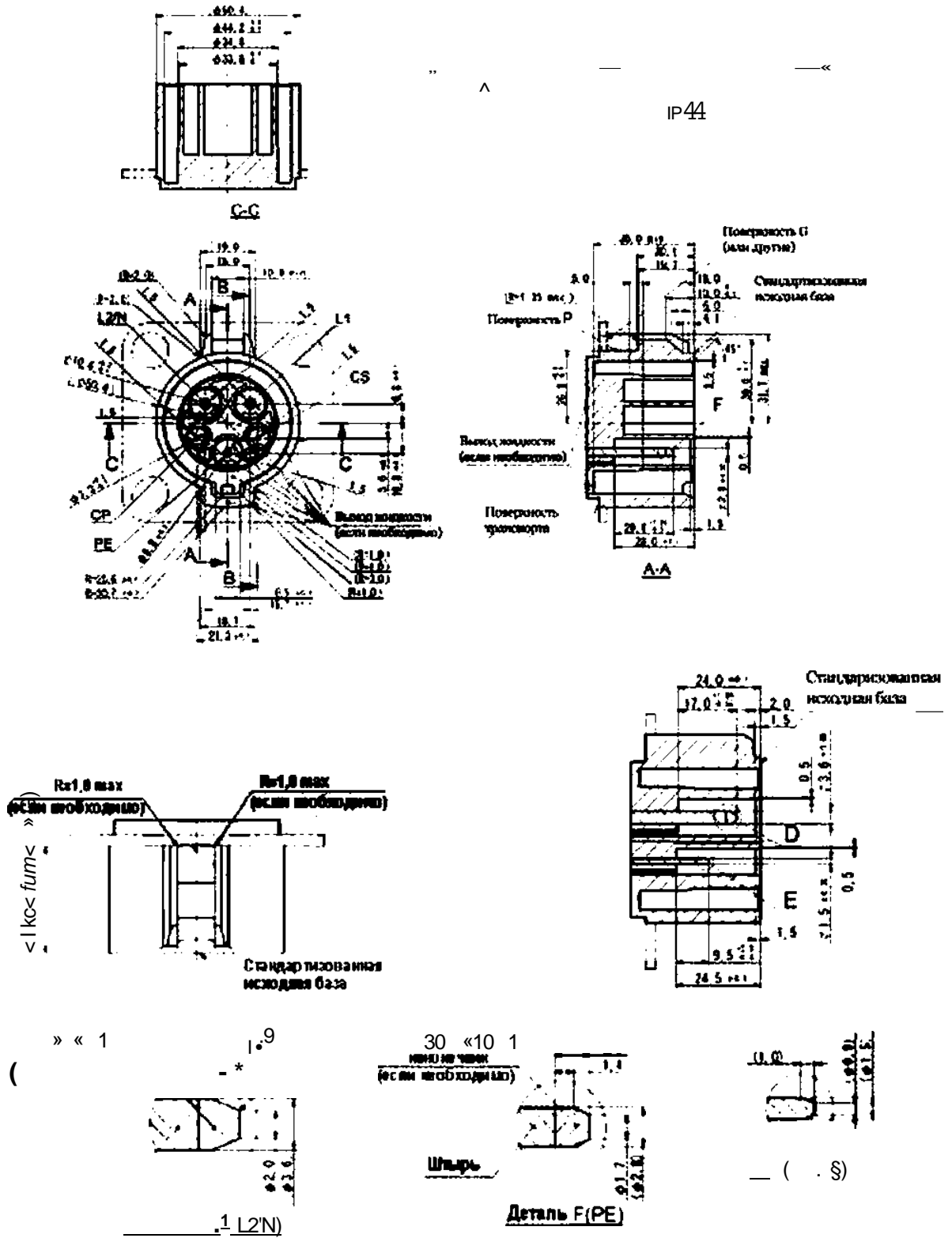

ОтН6иMUj
 10 max, 0.15; 50 max 0.2] 00 max: ± 0.3j 30'

62196*2—2013

2-I (2)

250 32

tmftei

>
!IPM

Варпюнуионтияифи
twi

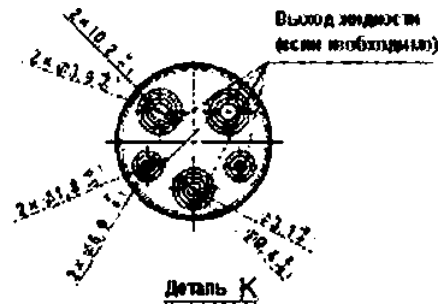
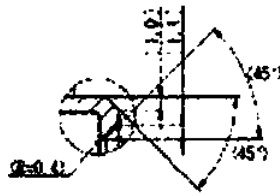
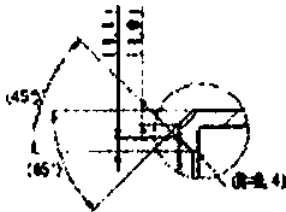
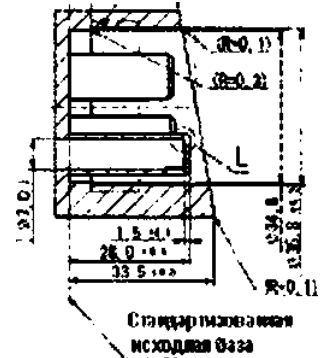
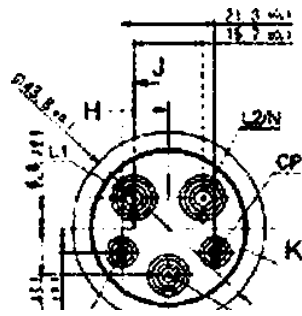
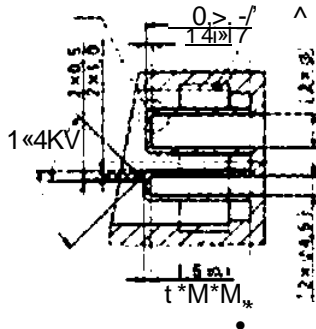

10<max ± 0.1 50max 10.2 100max 10.3 : 130

62196-2—2013

2-1 (3)

IP44

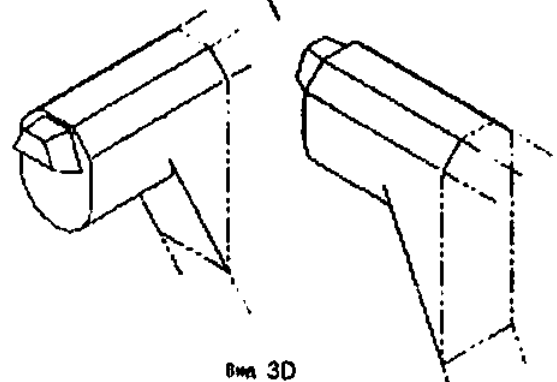
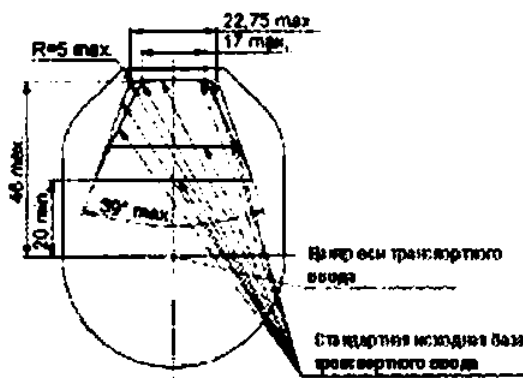
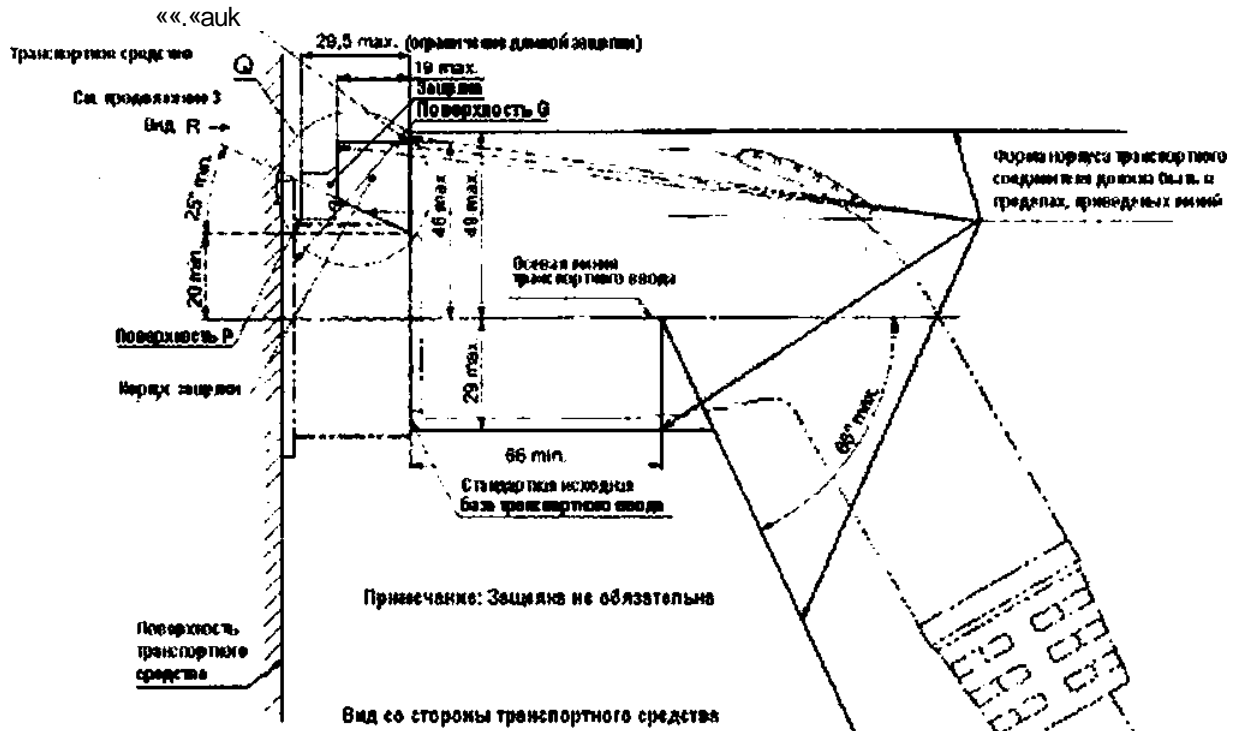

**Ⓜ

tMj|Rr>9ueMieopMr?iuMW

" (1 « * « »

WKWMMMaiKtMwima'VMOOfteixptaeikV

2-1 (4)
(3)

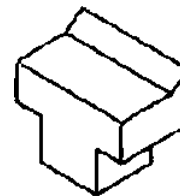
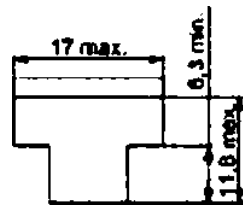
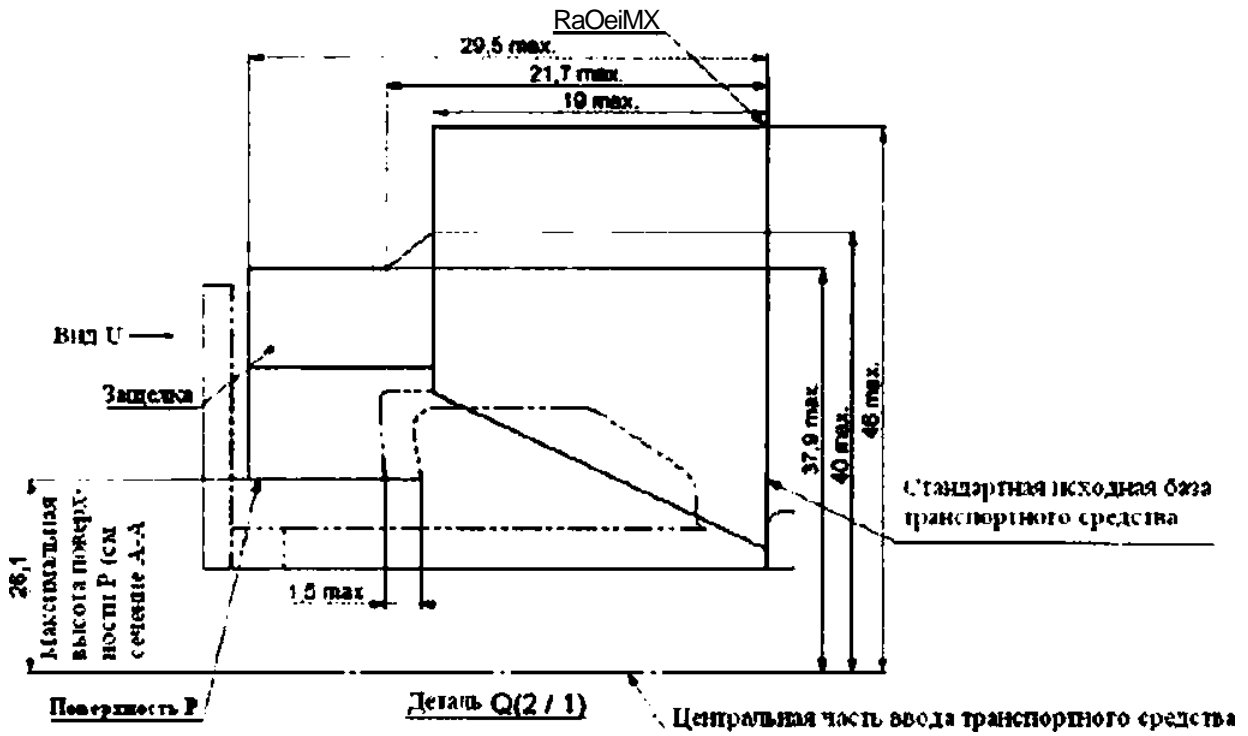

Вид 3D

V - nowaeswi

<

vt

!

!

dki

*

62196-2—2013

2-1 (5)

(4)

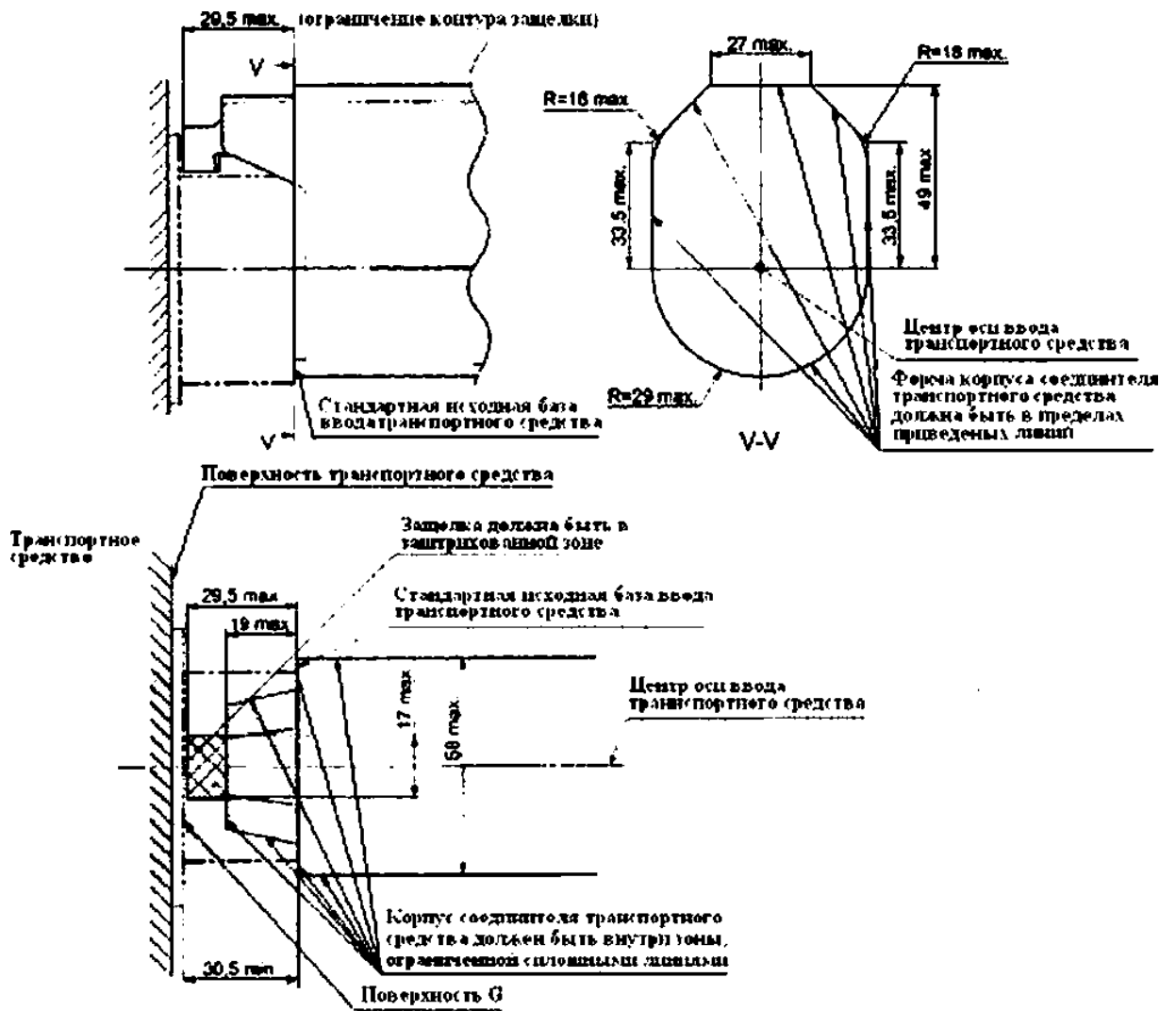

1ft <> >>* << >> * *

2-1a (1)

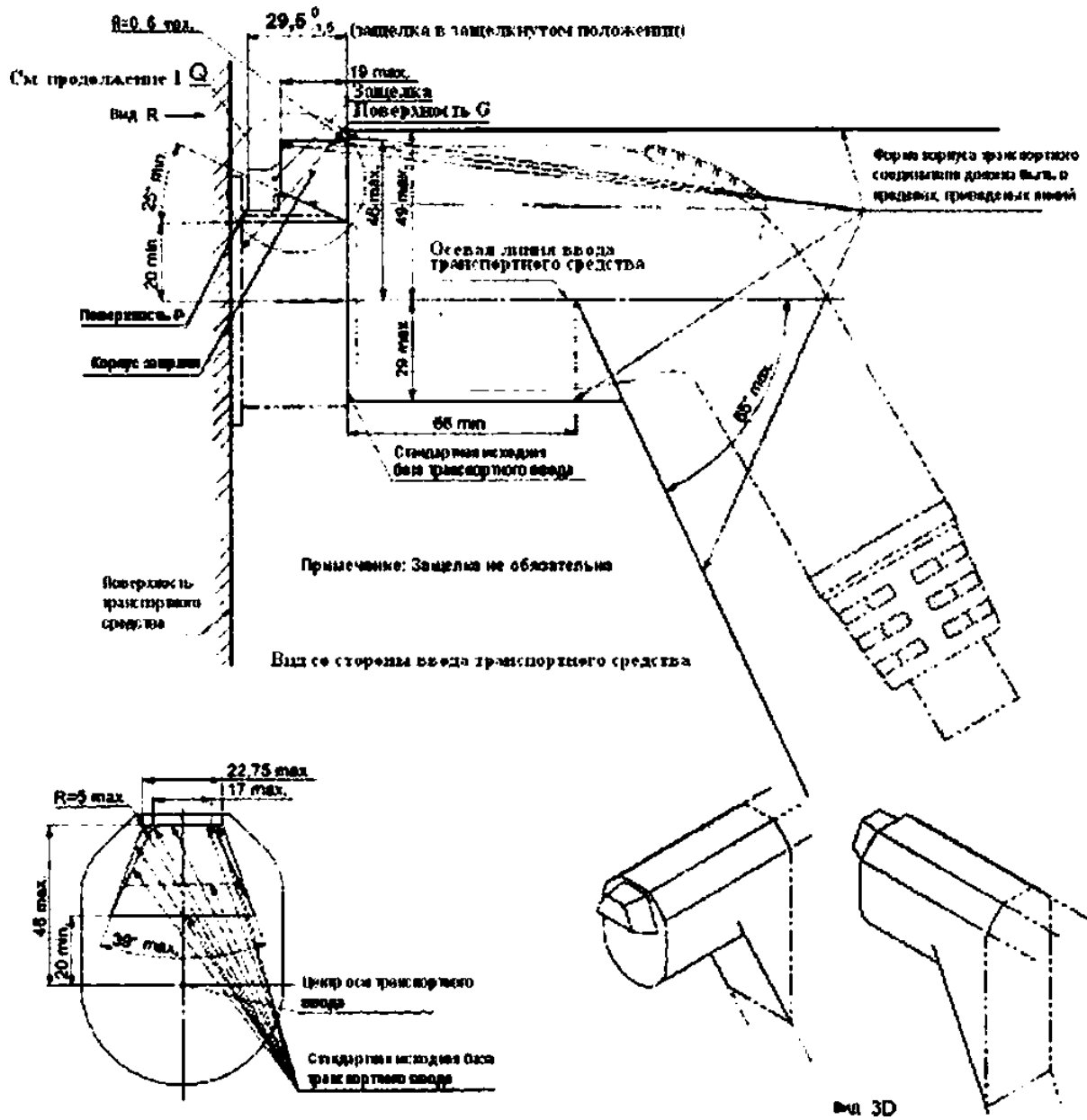

«• .!!.

» mippaviMi « — — KswcwtA

62196-2—2013

2-1a (2)

(1)

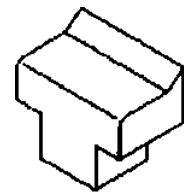
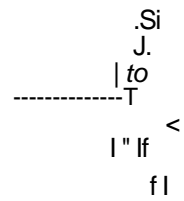
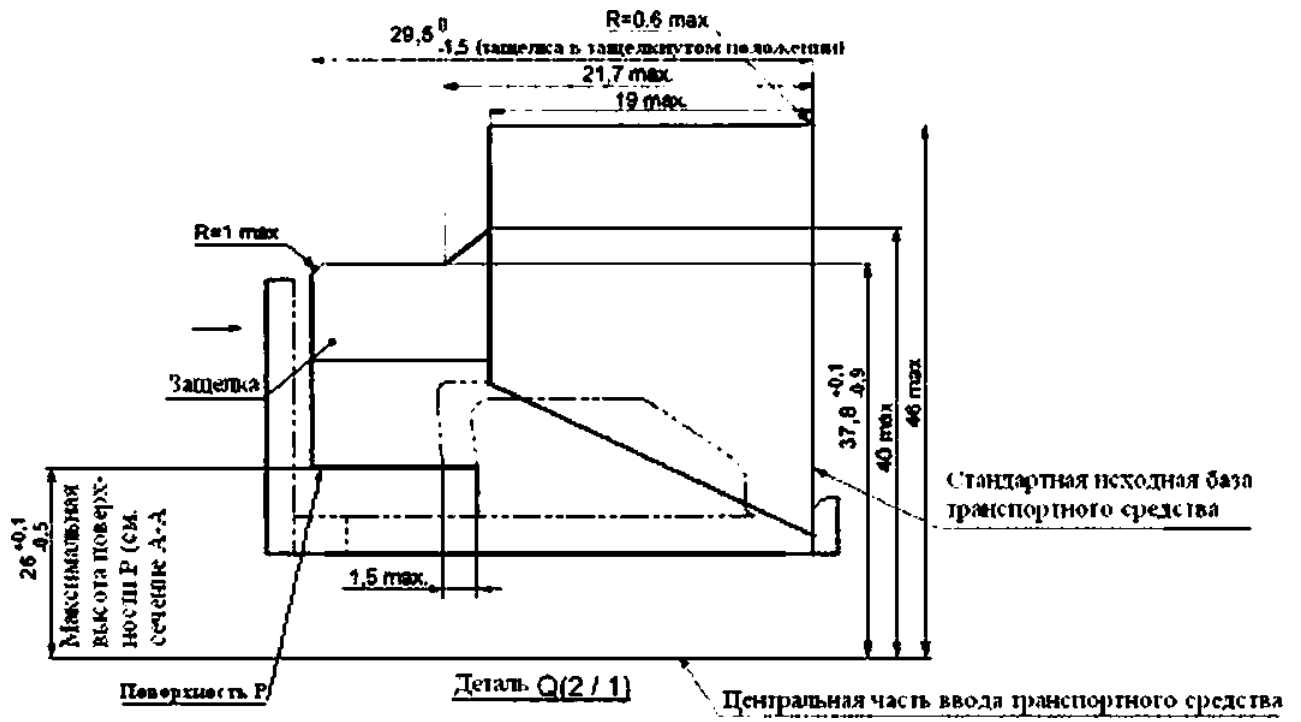

U-

(2-la (2) 3)

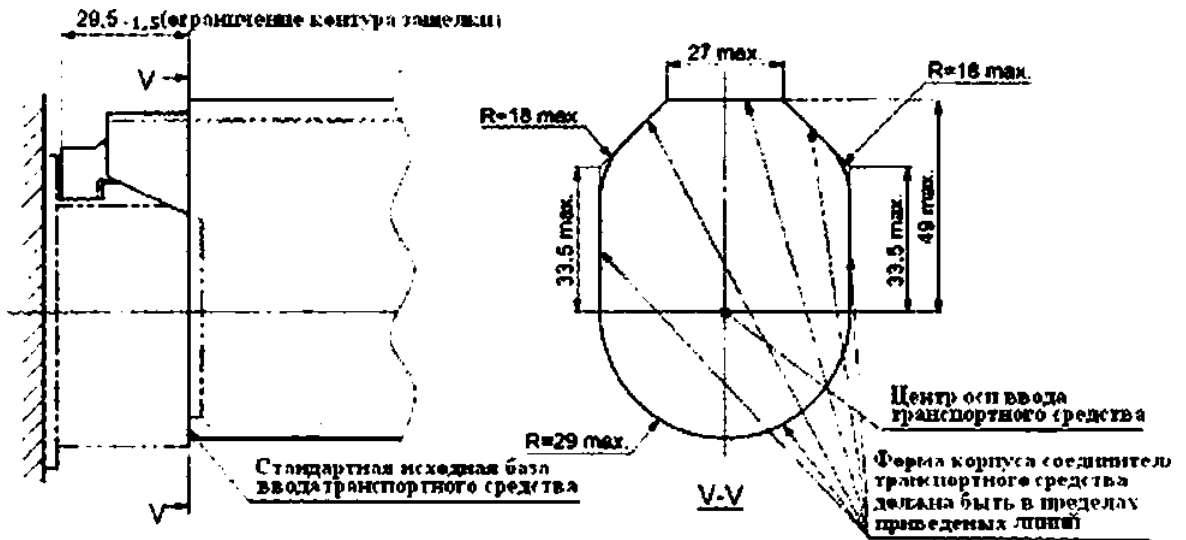

Поверхность транспортного средства

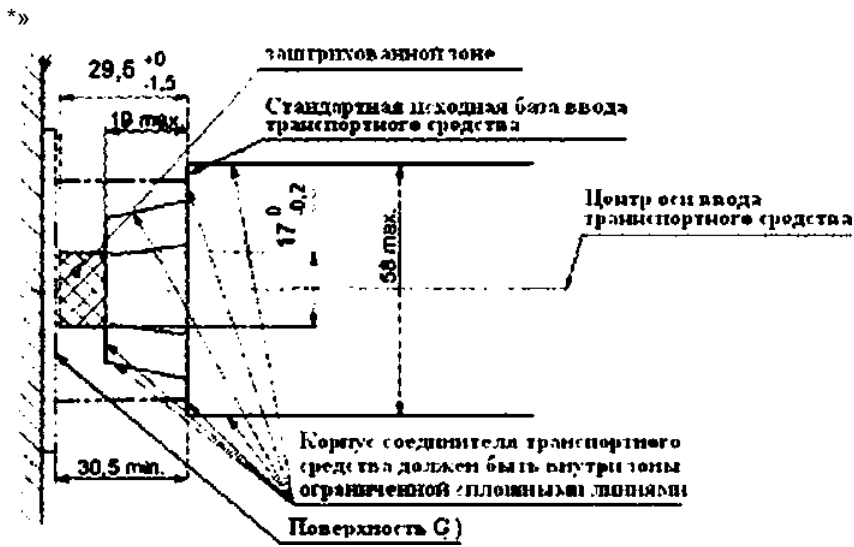

< i> iaufi .met
< ; < > << >> *

62196-2—2013

2-

2

63

70

480

2-II (IIa-IIh)

2,

70

460 .
2

63

:

! -

2-

1:2010 ():

61851 *

61851-1 (.5 ()).

104 -

2

	(3) 2-	() 2-JkJ	(2 3) 2-111
(3) 2-11		u or	u
(1) 2-11	8		8
(2 3) 2-11©	*		
*1 61 o	2	,	.

2-Ilg 2-IIh

3-

/

2- (1)

480
70

63

(vi)

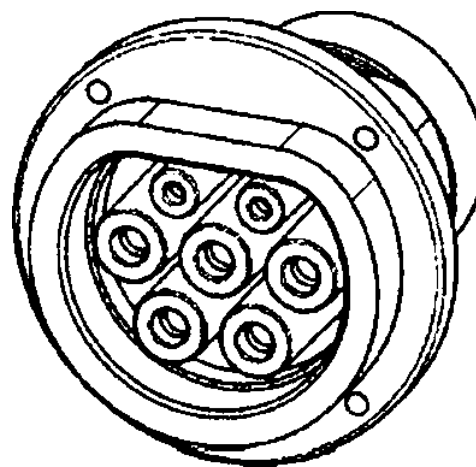
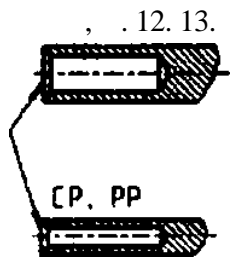
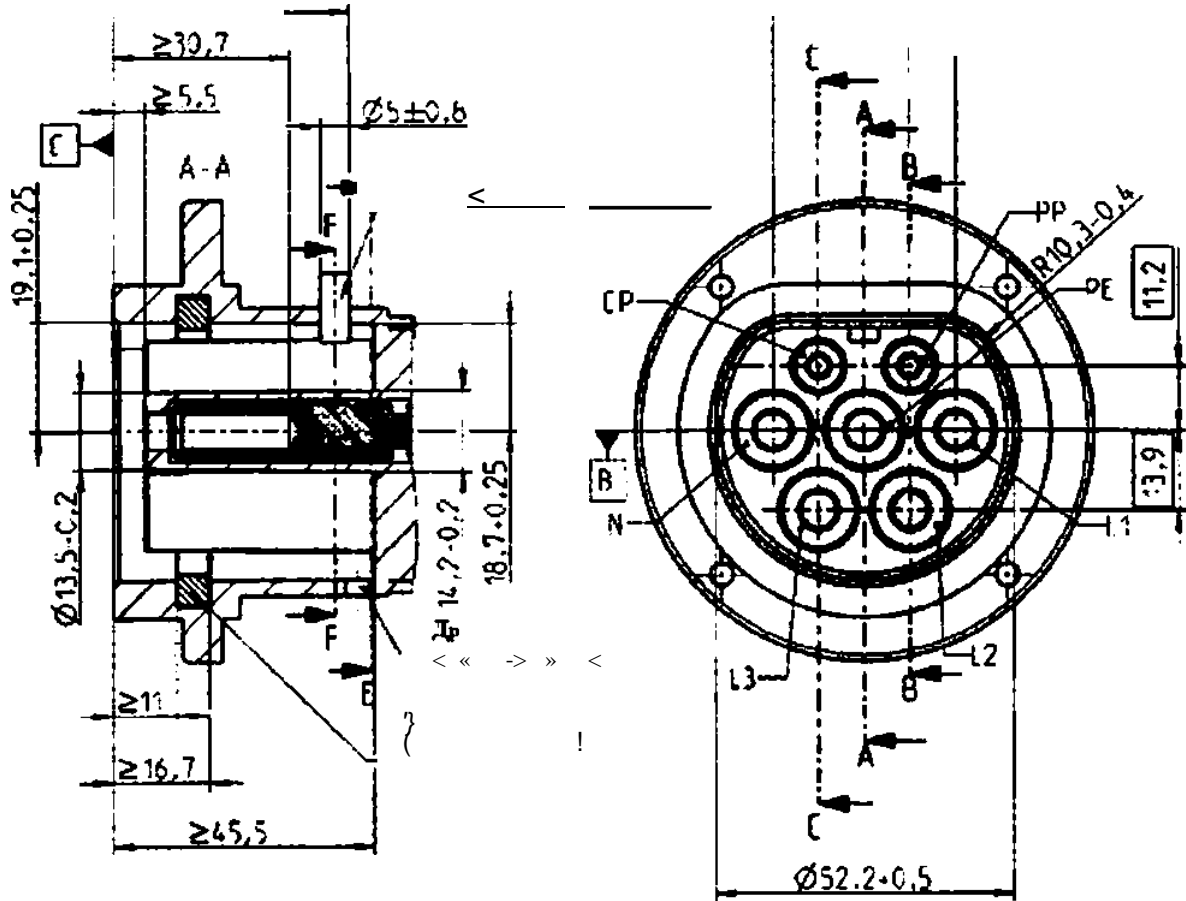

-R.0.5 0,"

P 62196-2—2013

2* (2)
1)

480
70

63

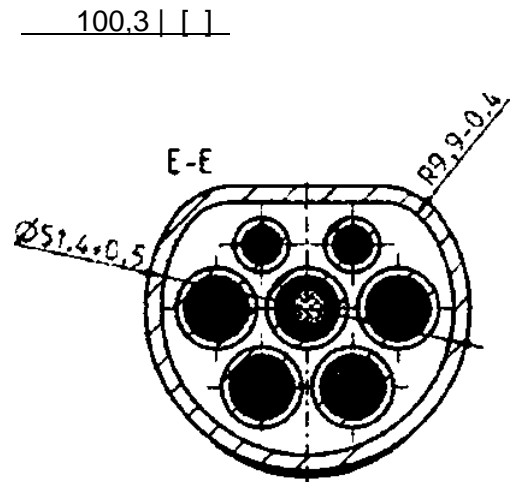
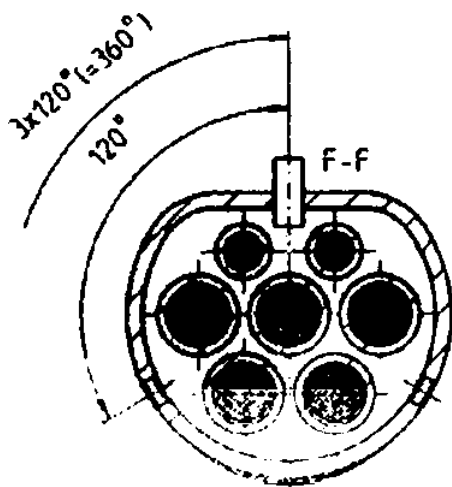
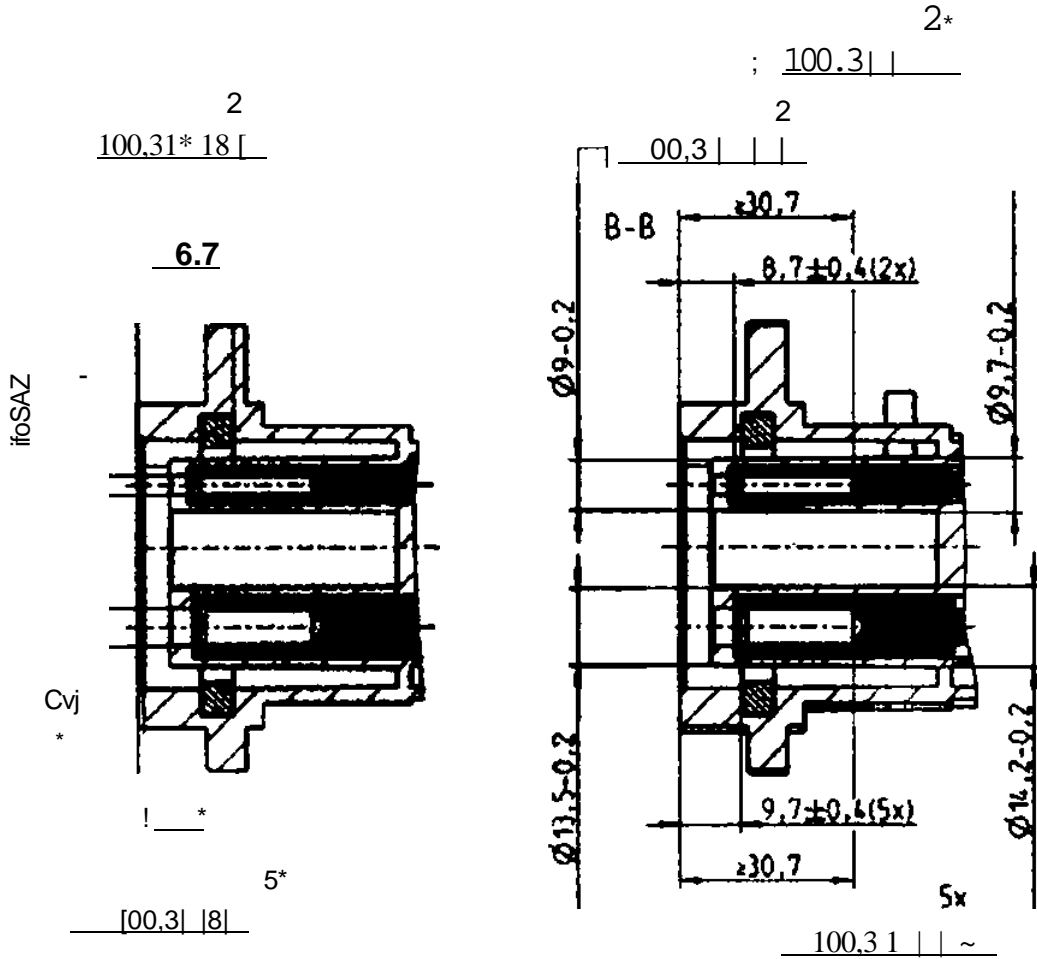

« - 0.5-0,"

2* (1)

480

70

63

1

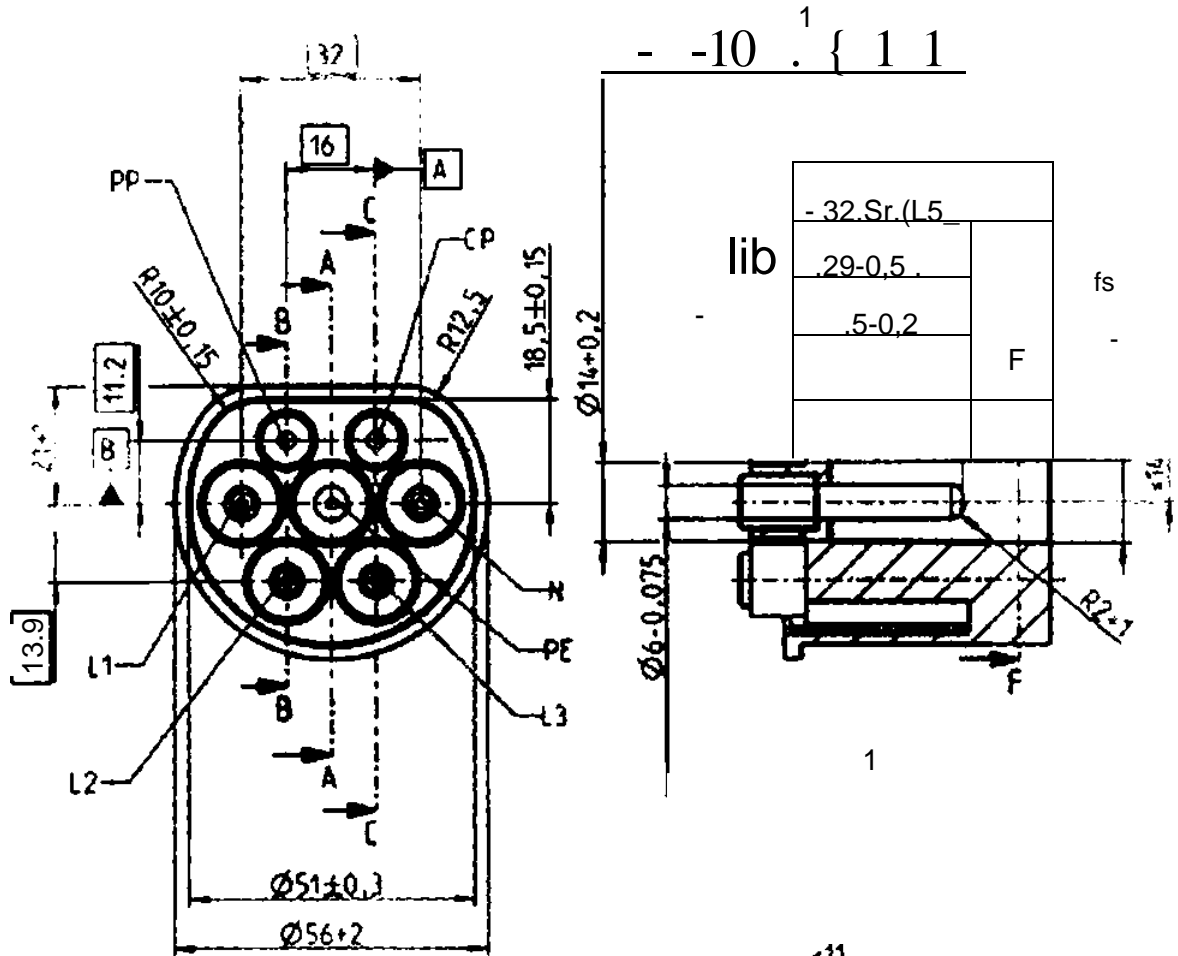

ppMPTinunai.

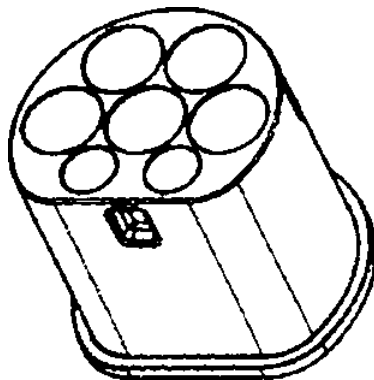

• R0.5 - 0,7

repMoTirtaipai - R.t=0*

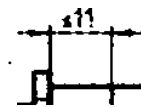

• +*+

~ ^

>16.7

P 62196-2—2013

2-Ilb (2)
1)

480

63

70

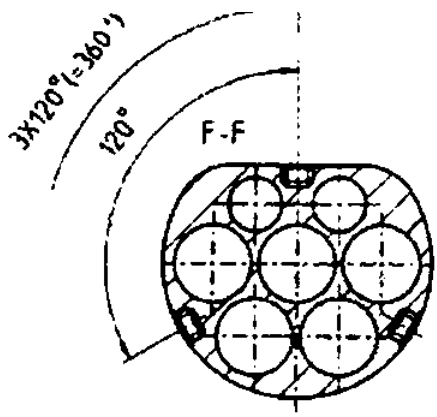
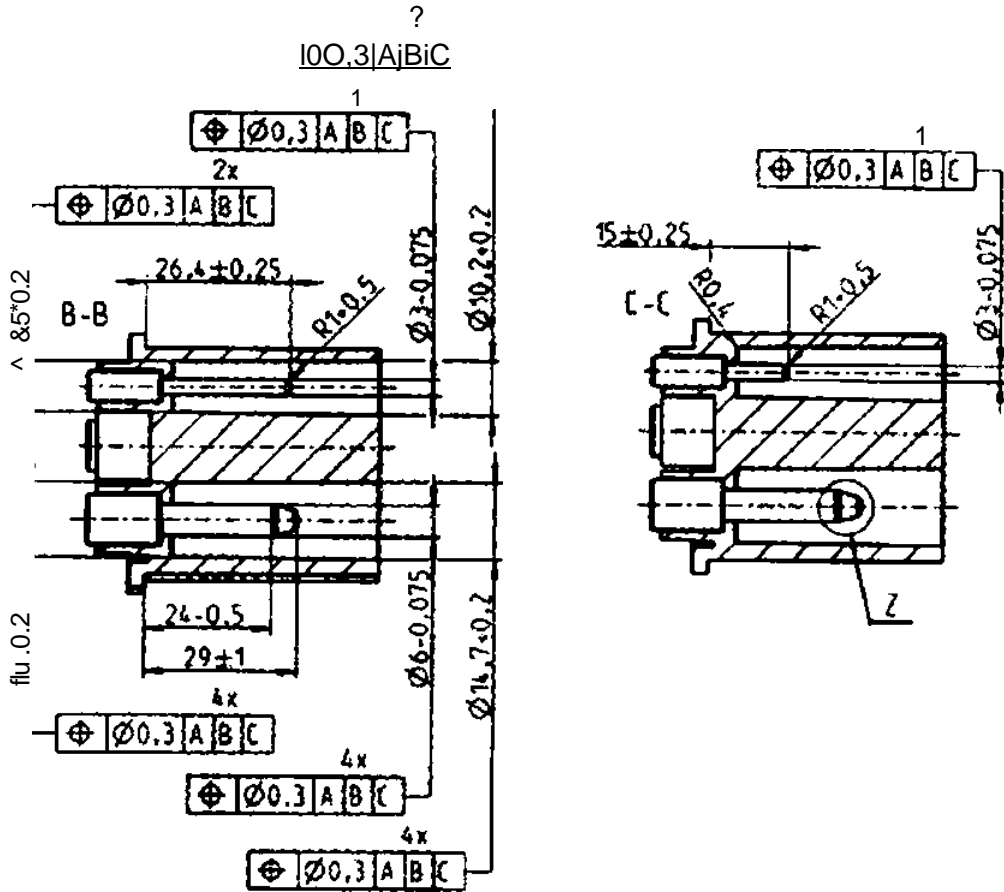

В указанной зоне перехода вилки не должно быть острых кромок

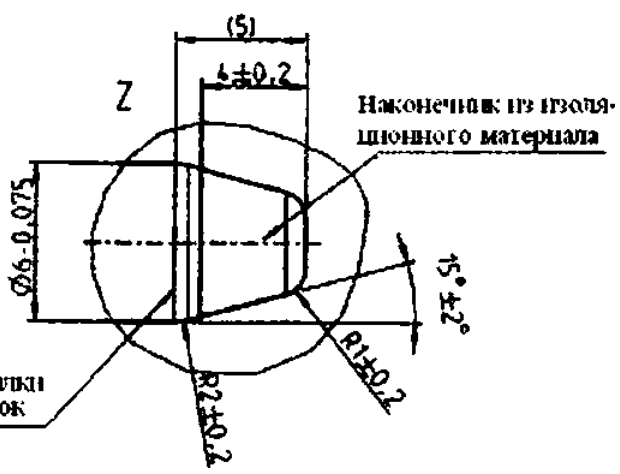

«&-1 .0.7

2- (1)

480 16

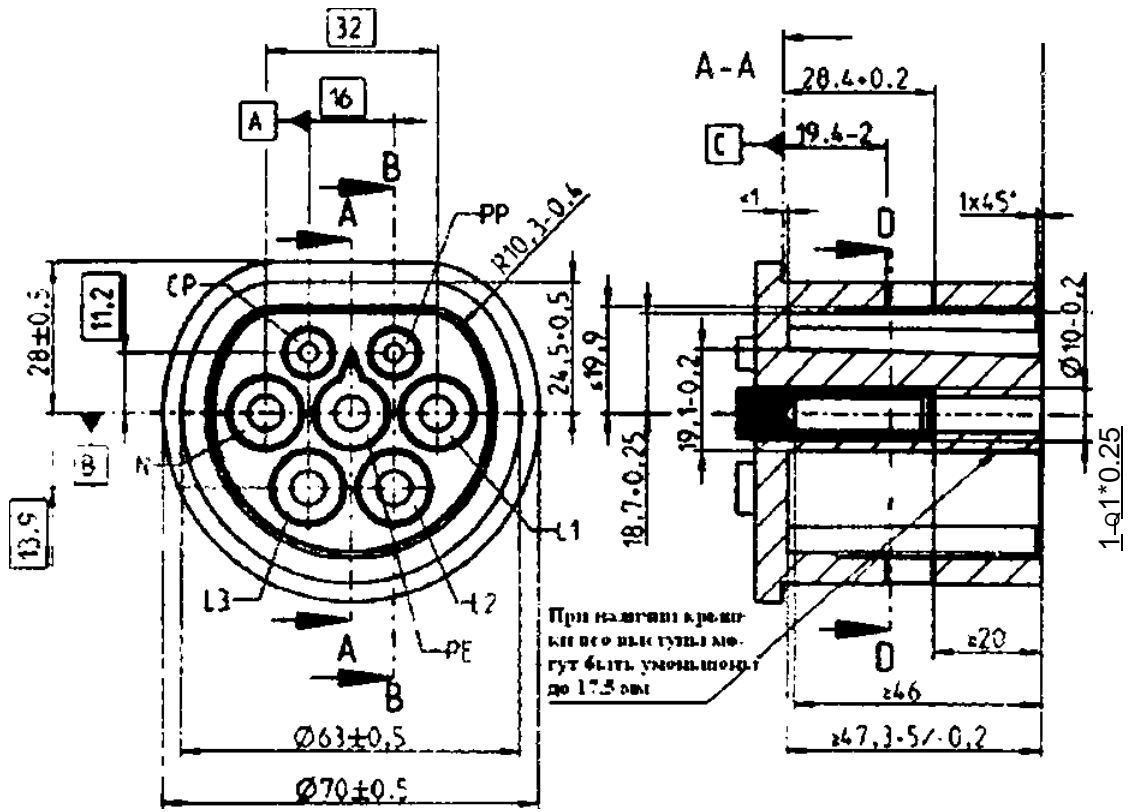

«6.8,

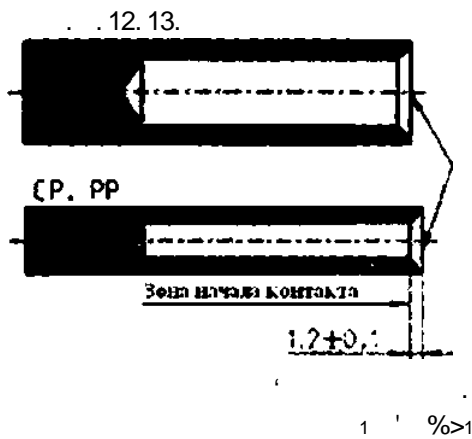

>(-R 0,5-0,“

Ra“0.”

62196-2—2013

2* (2)
(1)

480 16

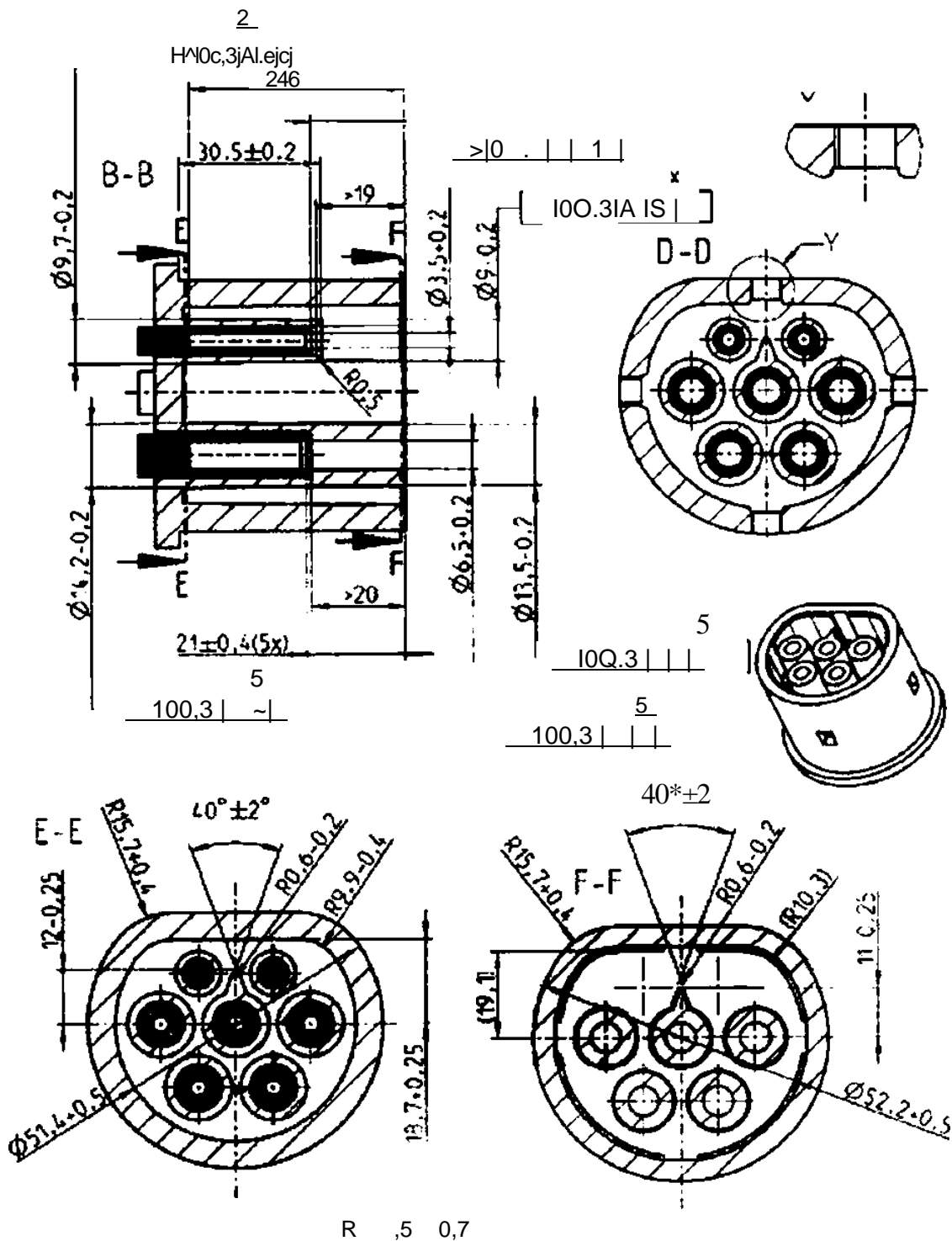

2-Илд (1)

480 ,

63

70

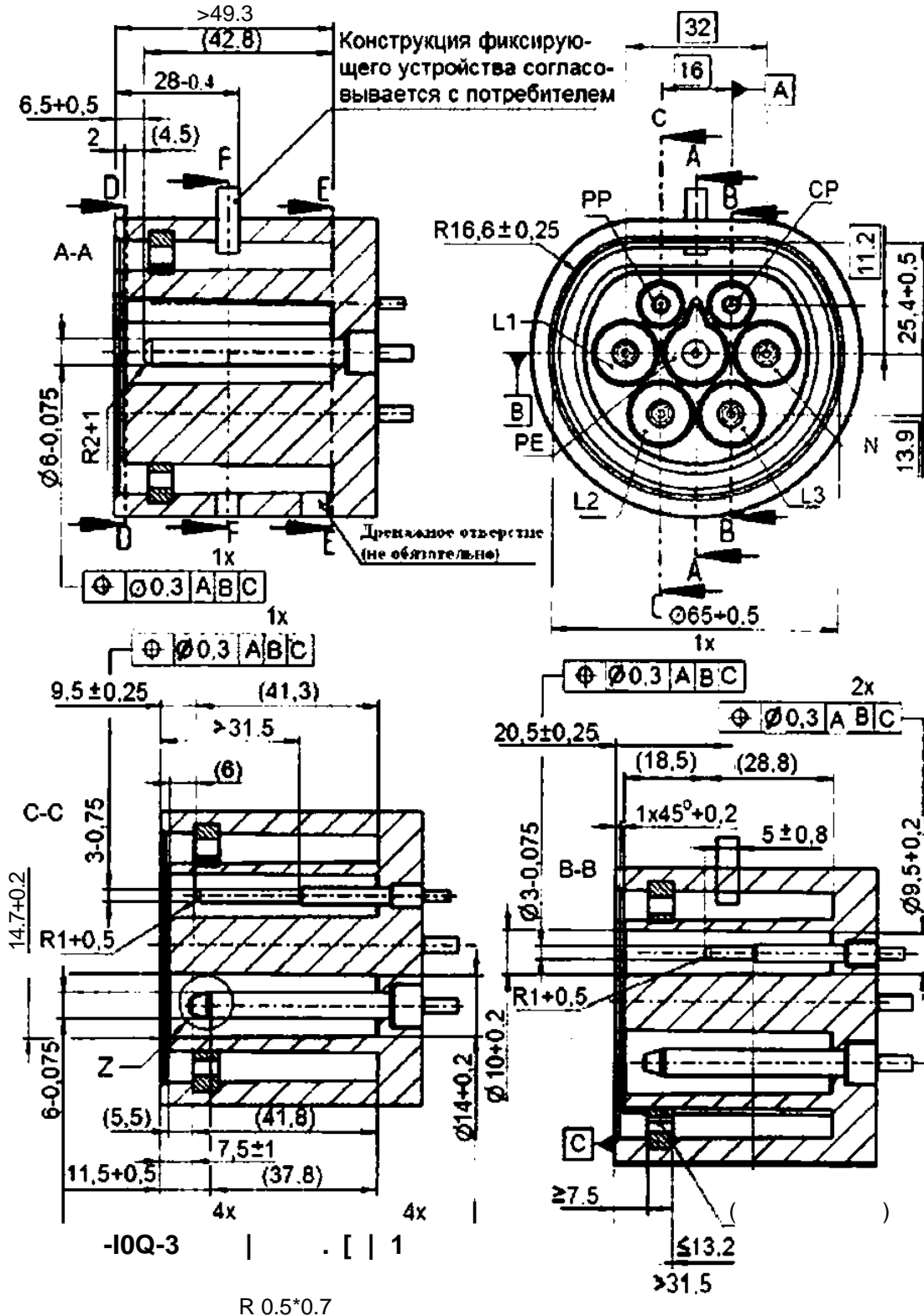

62196-2—2013

2-Илд (2)
1)

63

70

480 ,

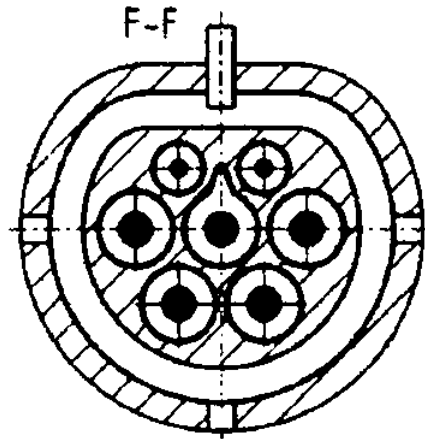
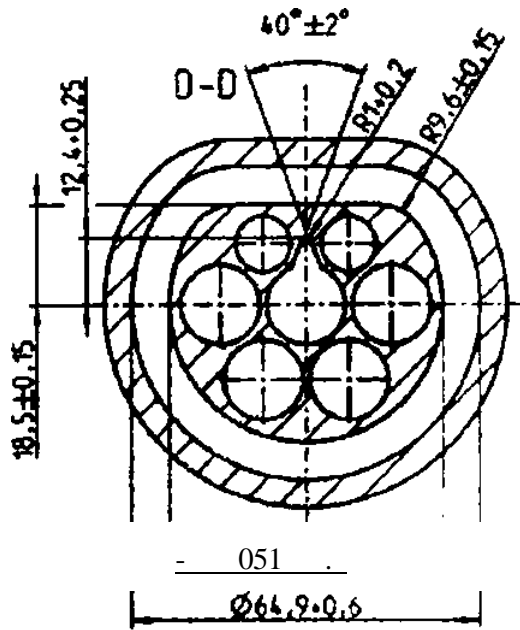

В указанной зоне перехода выпукл
не должно быть острых кромок

Наконечник из изоля-
ционного материала

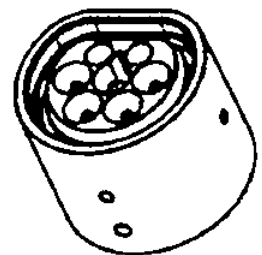
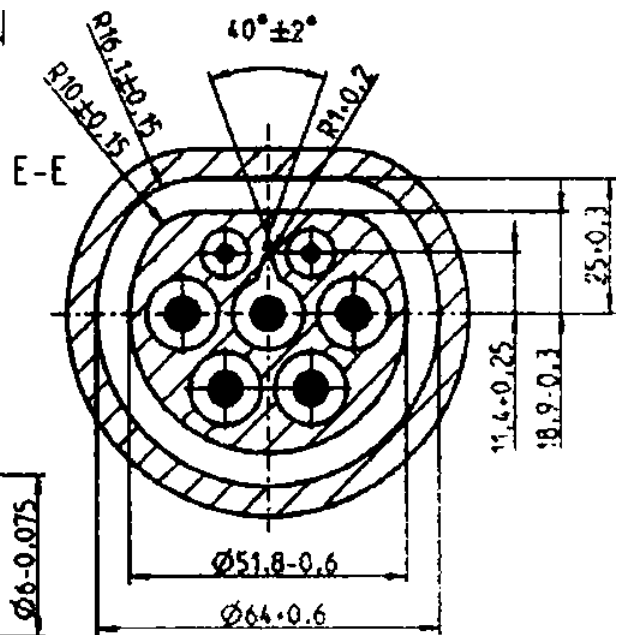
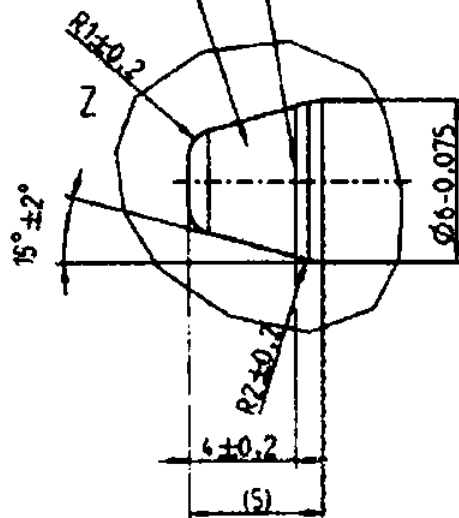

1» < R0.5 - ,"

2* (1)

480 ,

63

70

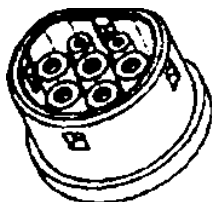
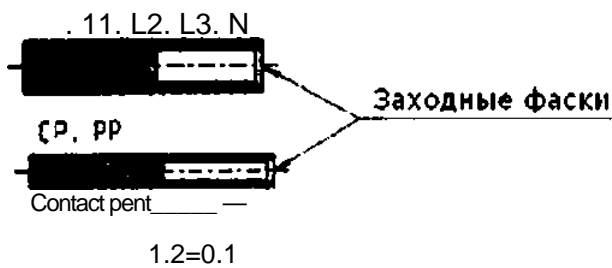
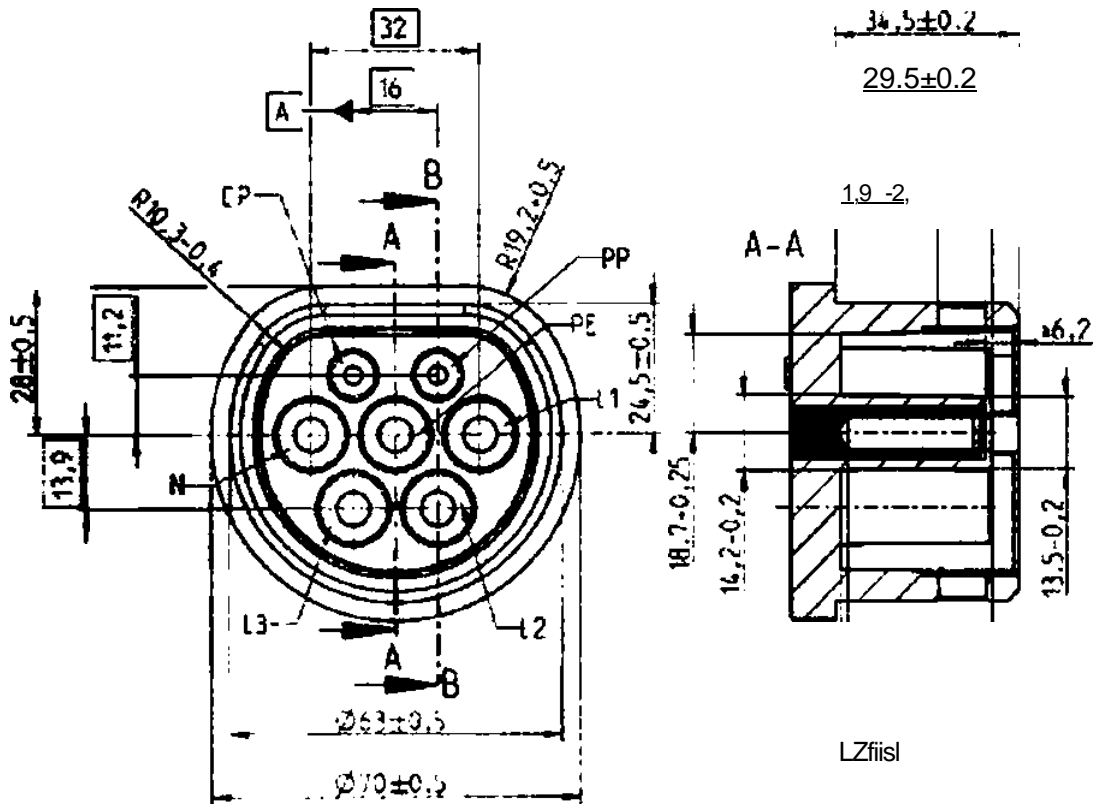

-R=0,S-0,7

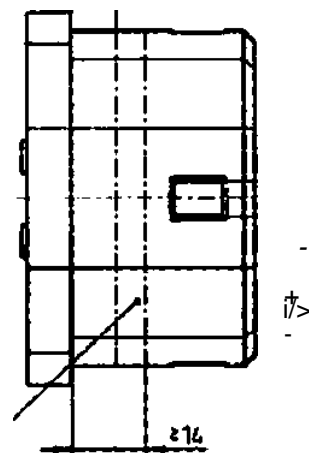

Ra 0,7

P 62196-2—2013

2-Ile (2)
(1)

480 ,

63

70

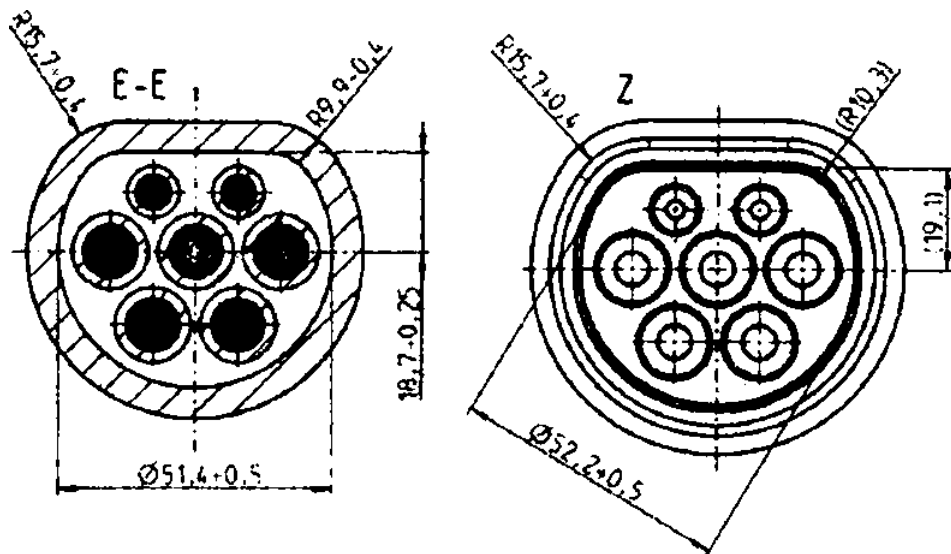
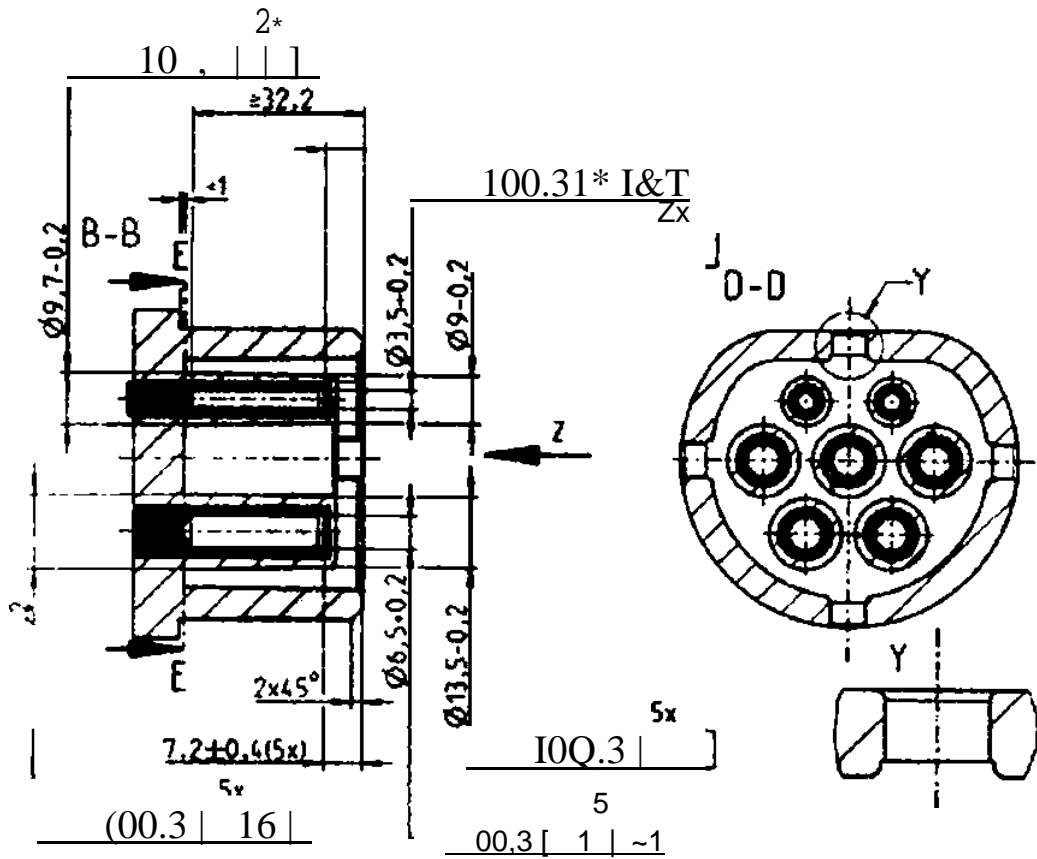

*-R=0,5-0»7

2-Ил (1)

480 ,

63

70

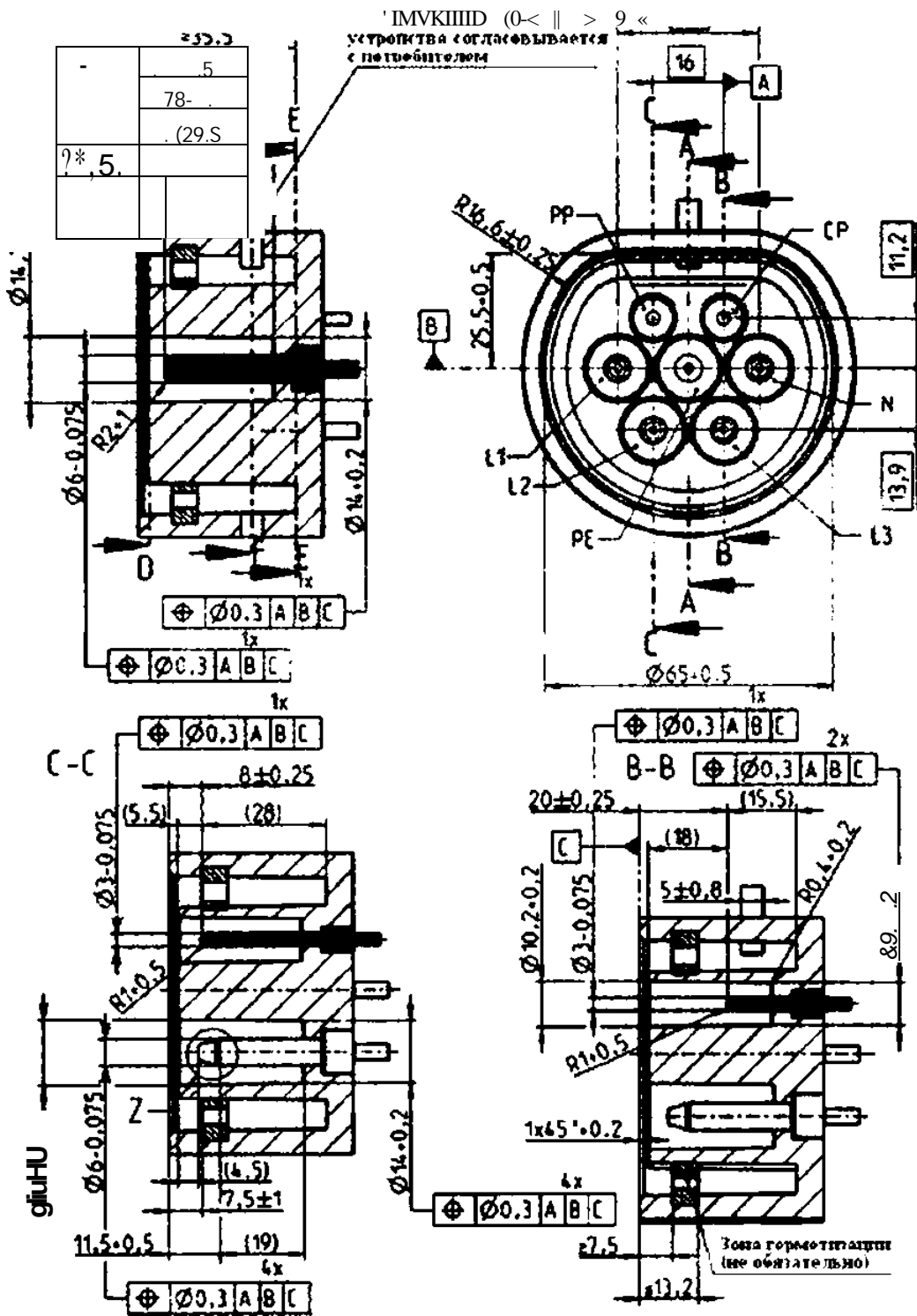

-ft 0,5-0,7

62196-2—2013

2-III (2)
1)

480 ,

63

70

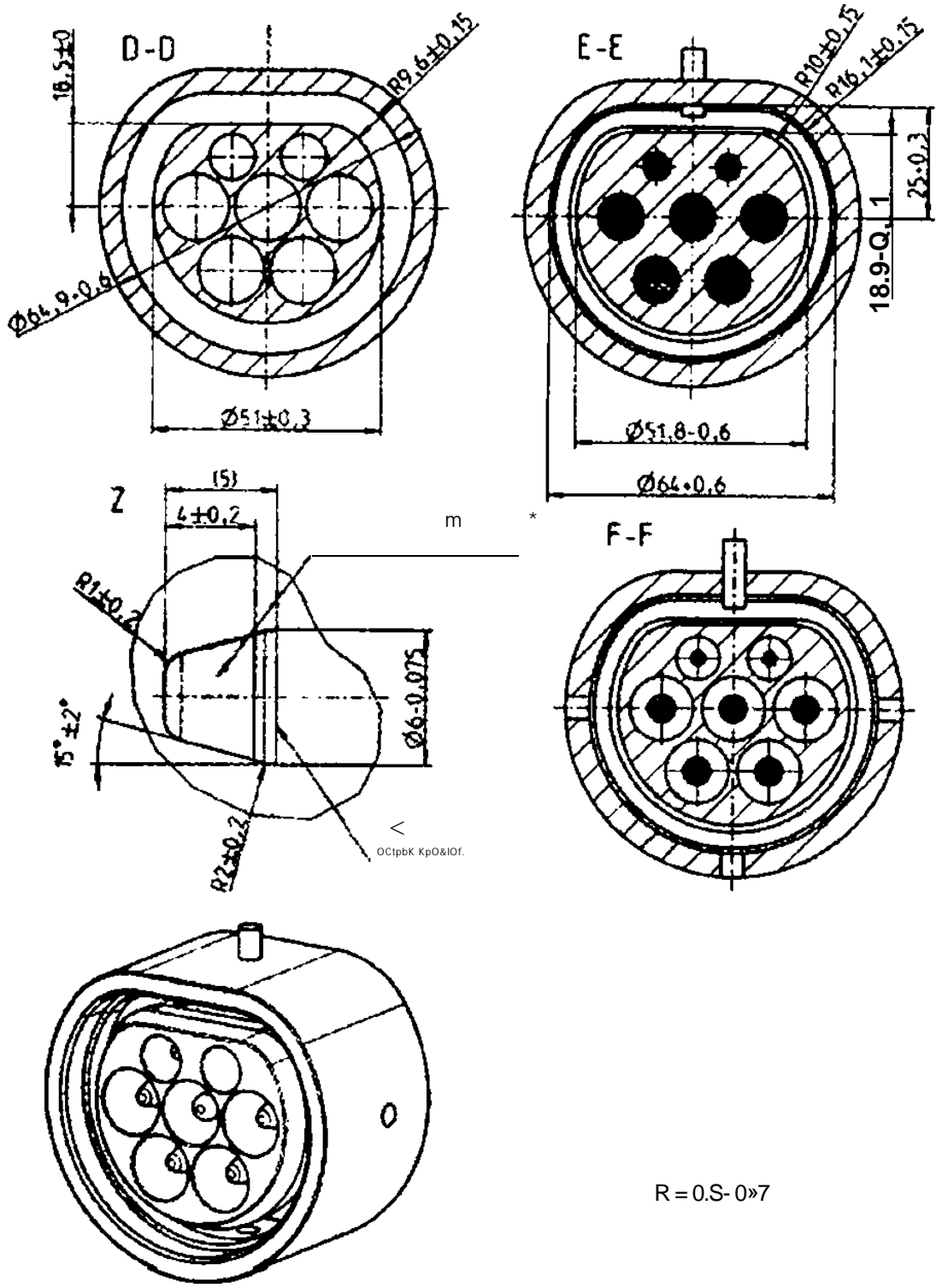

2-IIg

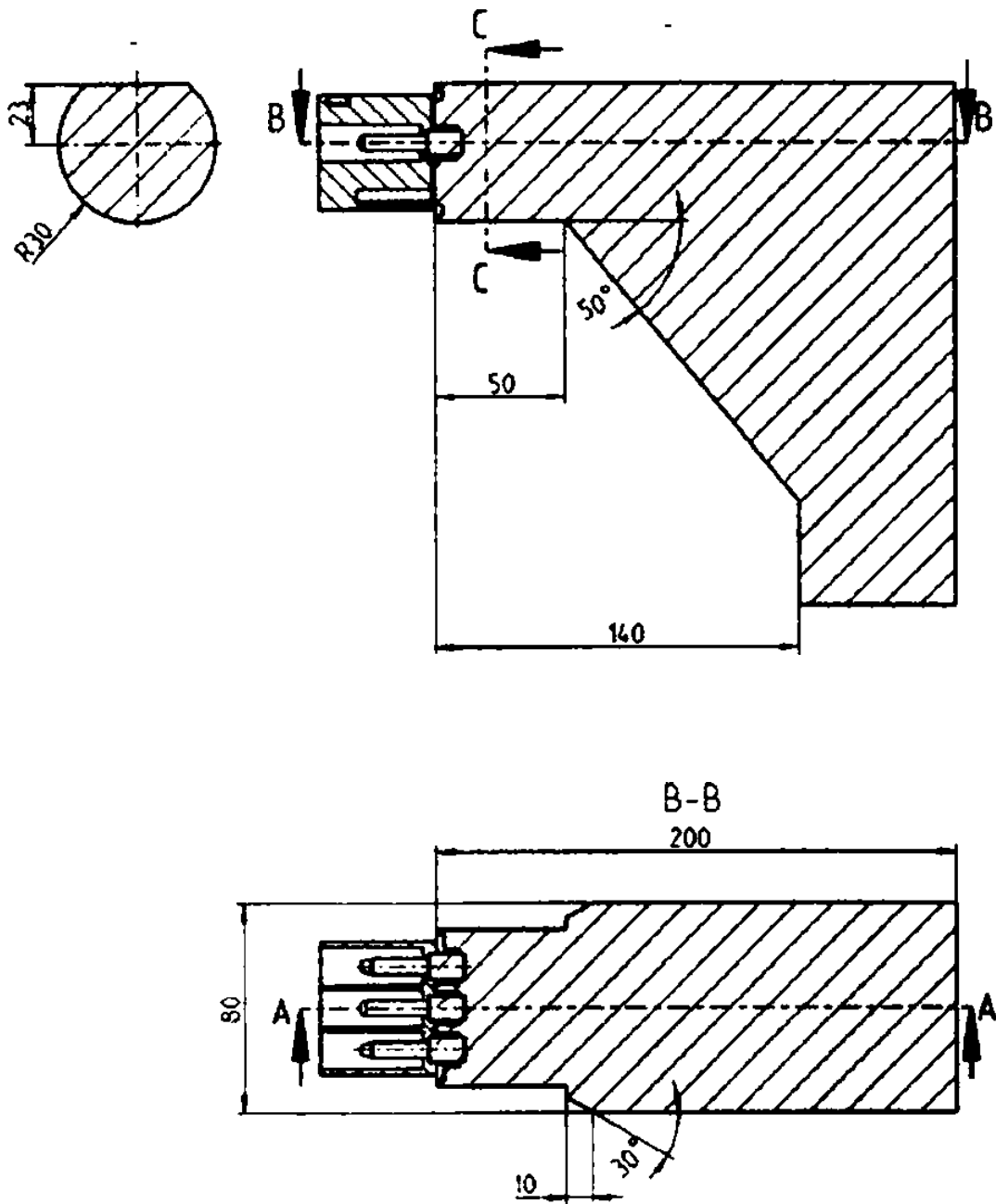

62196-2—2013

2-IIh

Размеры в мм

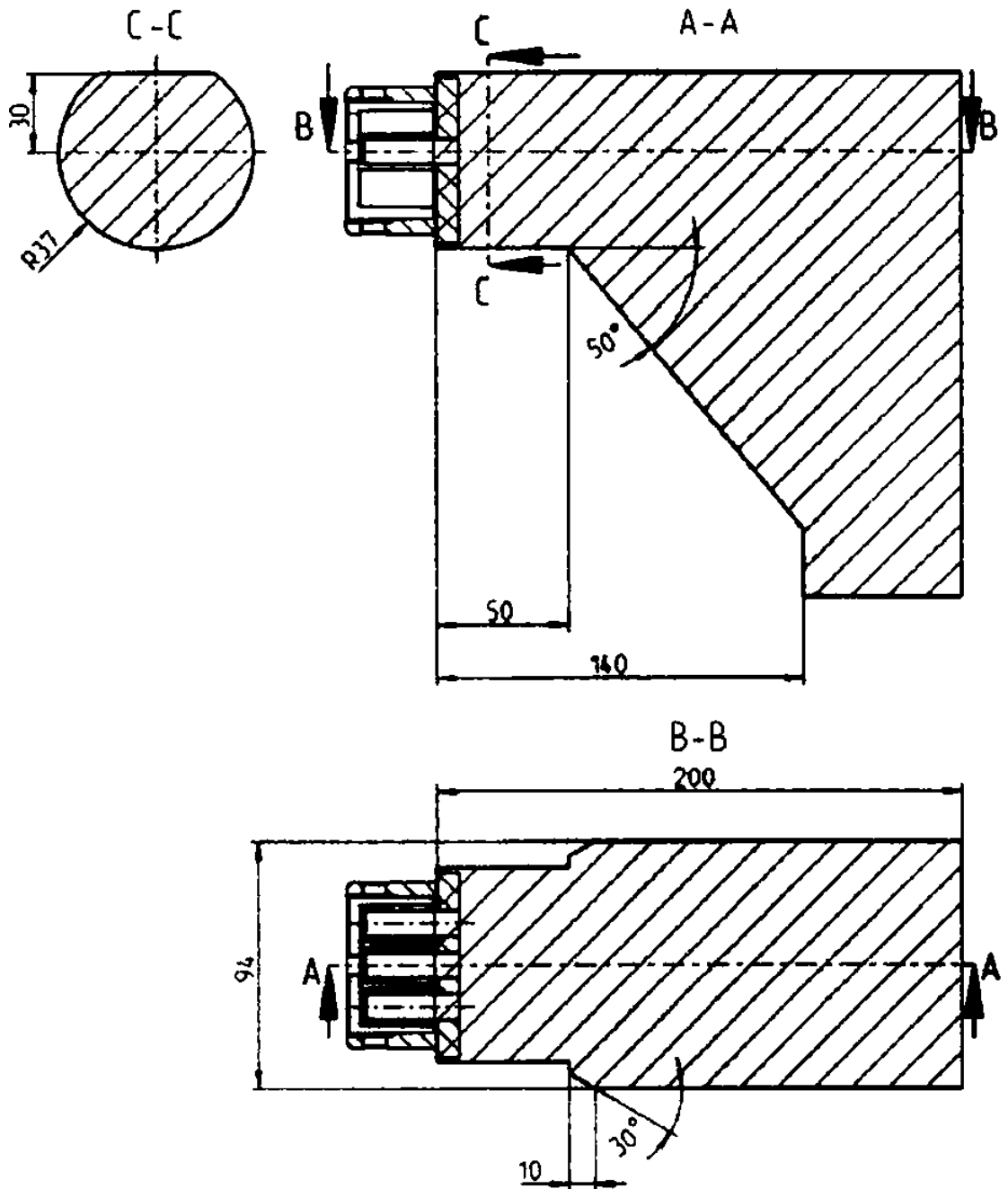

2-III

3

16 32 , 480

**250
63**

16 32

250 .
3

63

460

3

61851-1:2010;

63

1 -

•
61851-12010 ();

()

61851-12010 (6.5 (».

2-III d

2-

P 62196-2—2013

2- (1)

250 , 16

22^{1*}
20.5
18

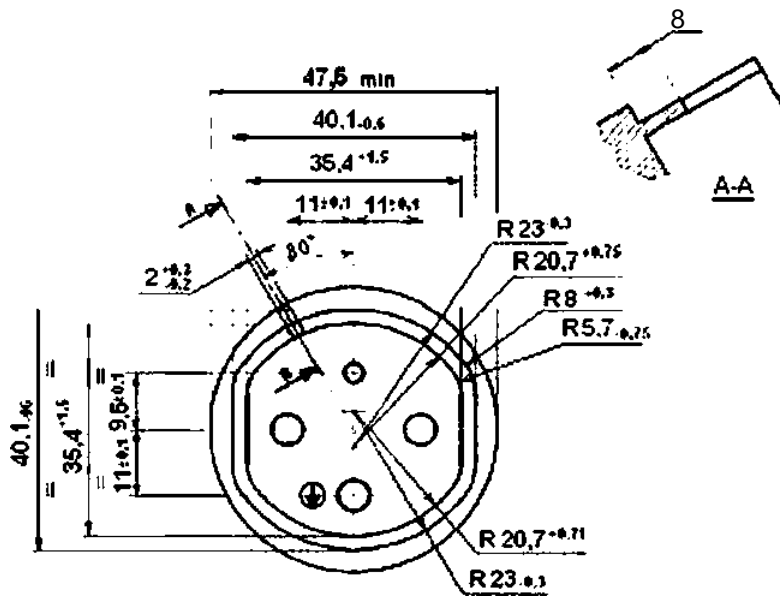

^4t0.1
16Q
22.6,

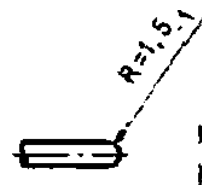

81
V

3 / /

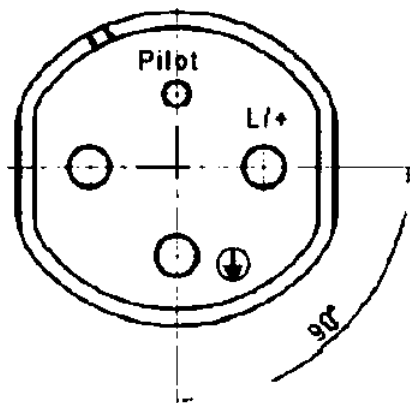

()

2- (2)
(1)

250 ,16

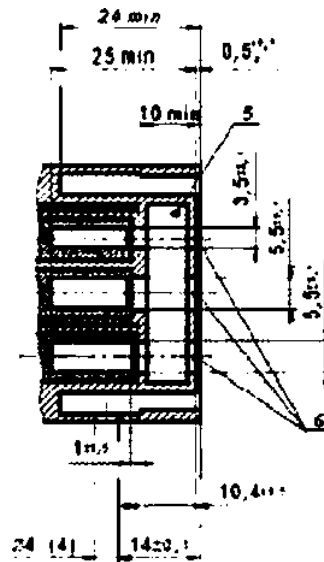
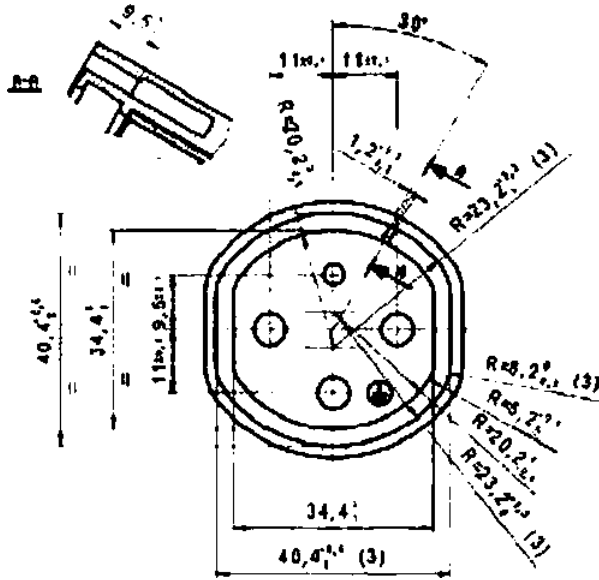

10 ()

()

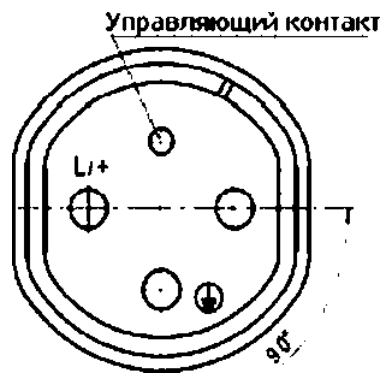

- 1-
- 2-
- 3-
- 4-
- 5-
- 6-

1.5-

10

4

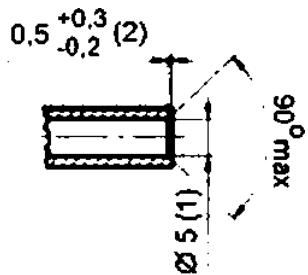

Земля/фаза/нейтраль

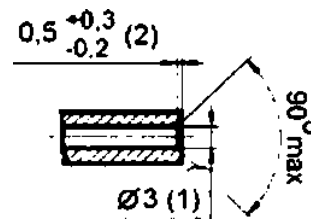

62196-2—2013

2- (3)
(2)

250 , 16

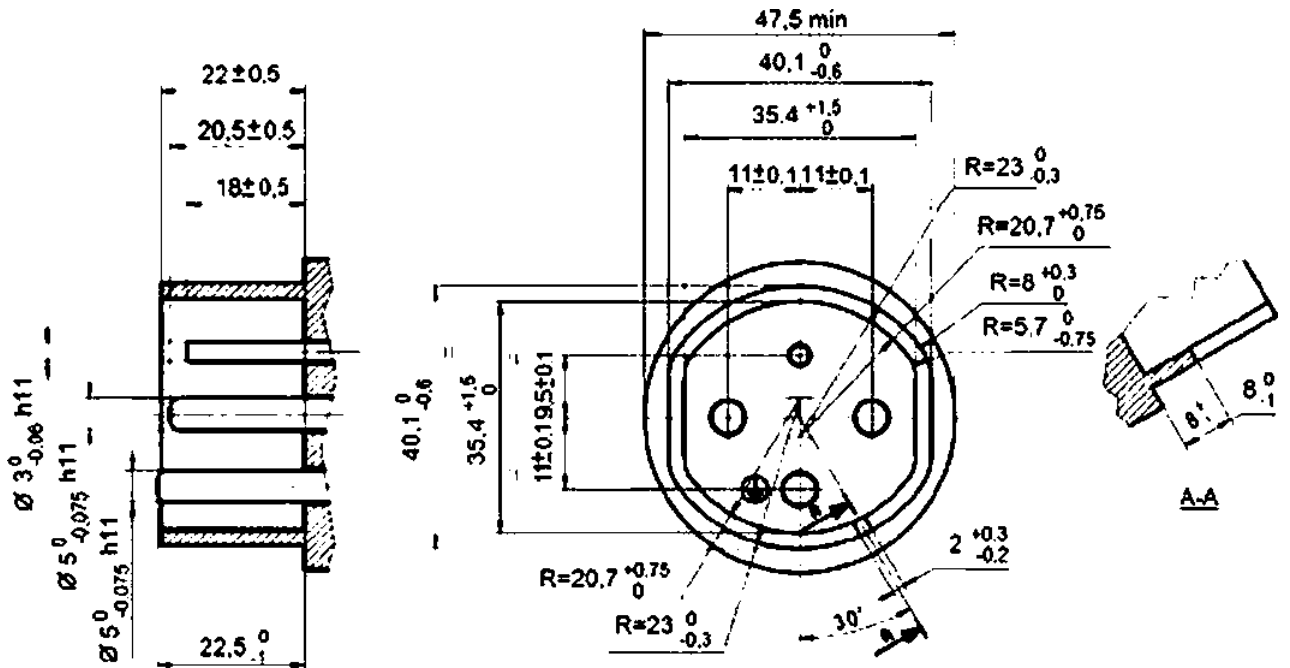

*».

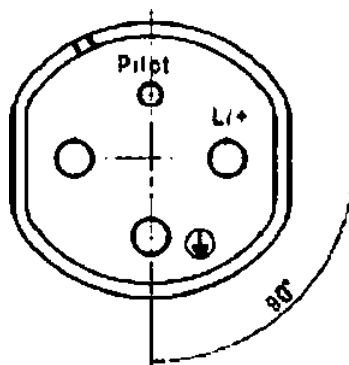
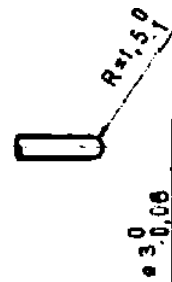

(2* (4)
3)

250 , 16

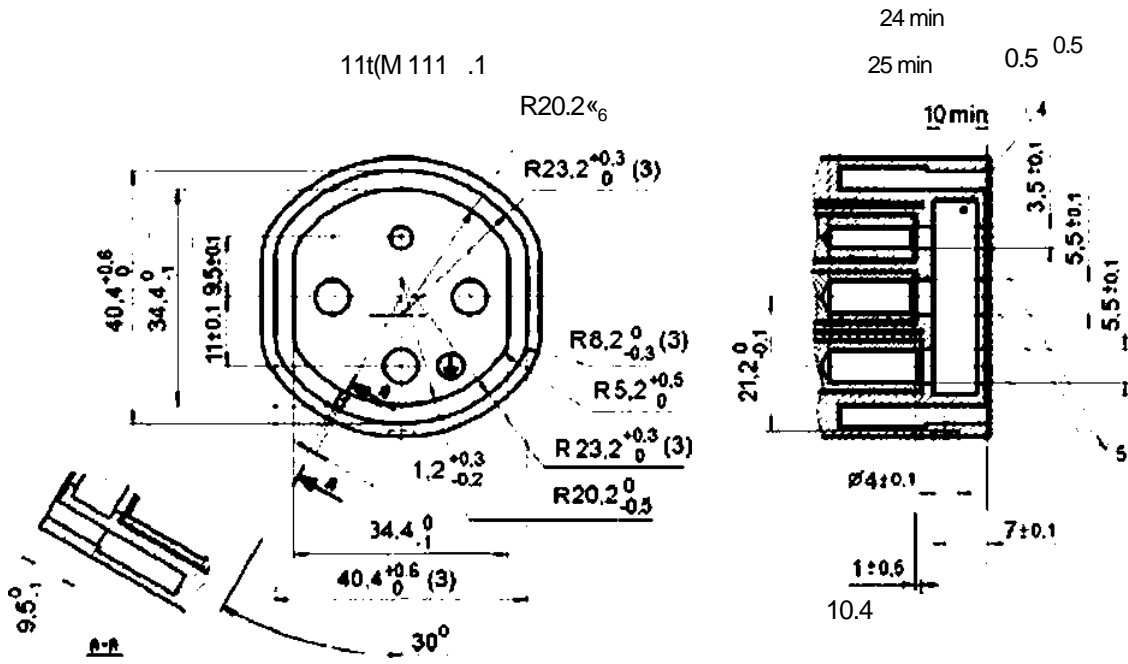

10 ()

()

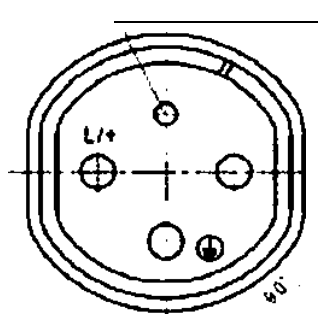

- 1-
 - 2-
 - 3-
 - 4-
 - 5-
- 10
- 1,5-

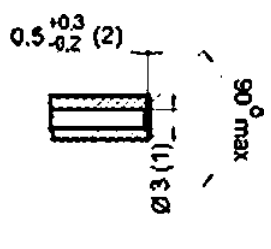
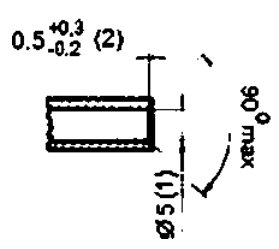

62196-2—2013

2- (1)

250 , 32

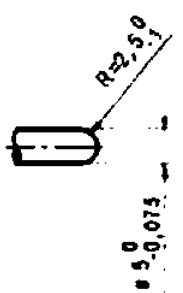
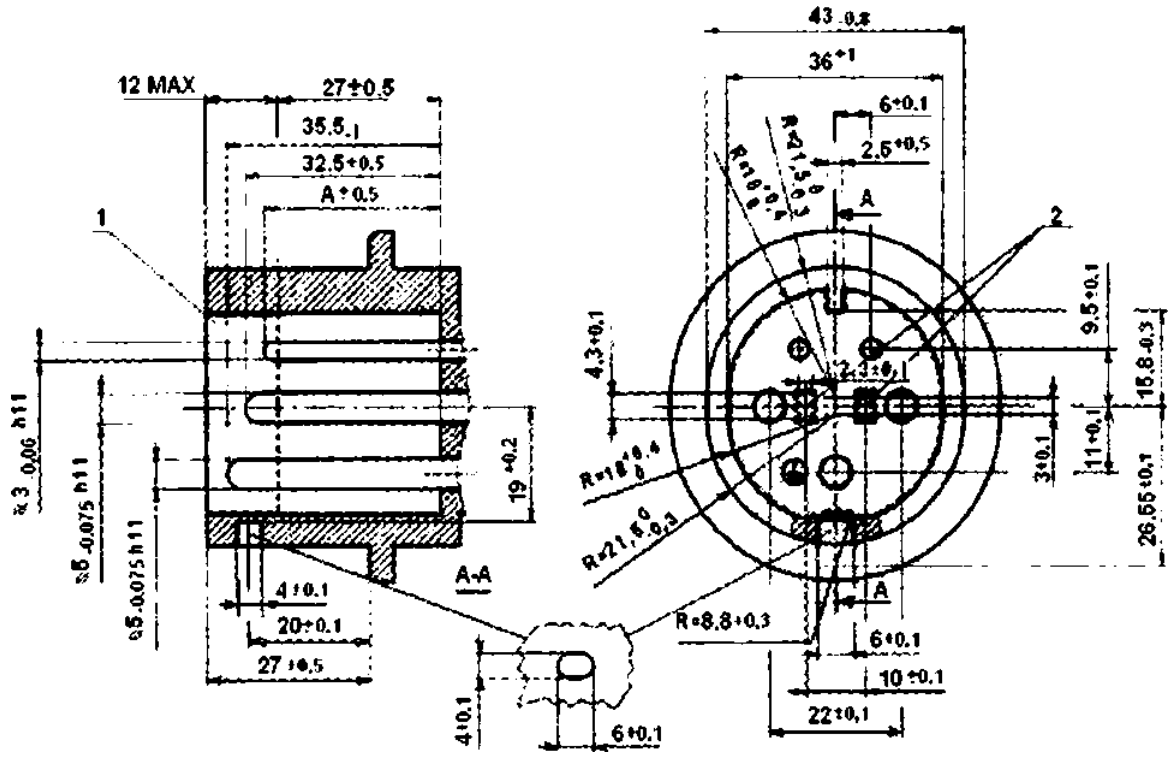

Земля/Фаза/Нейтраль

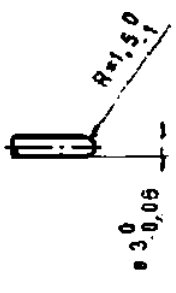

Вспомогательный контакт

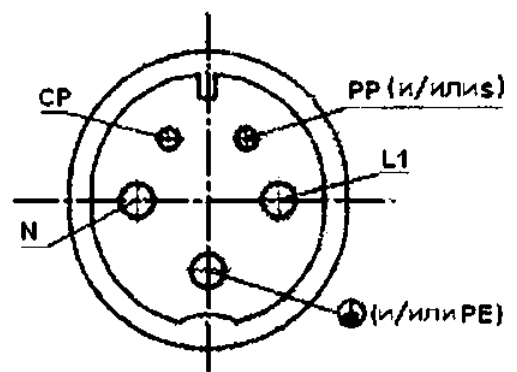

- 1-
- 2-

- -29.5 ;
- / CS-34

2-IIIb (2)

(1)

250 , 32

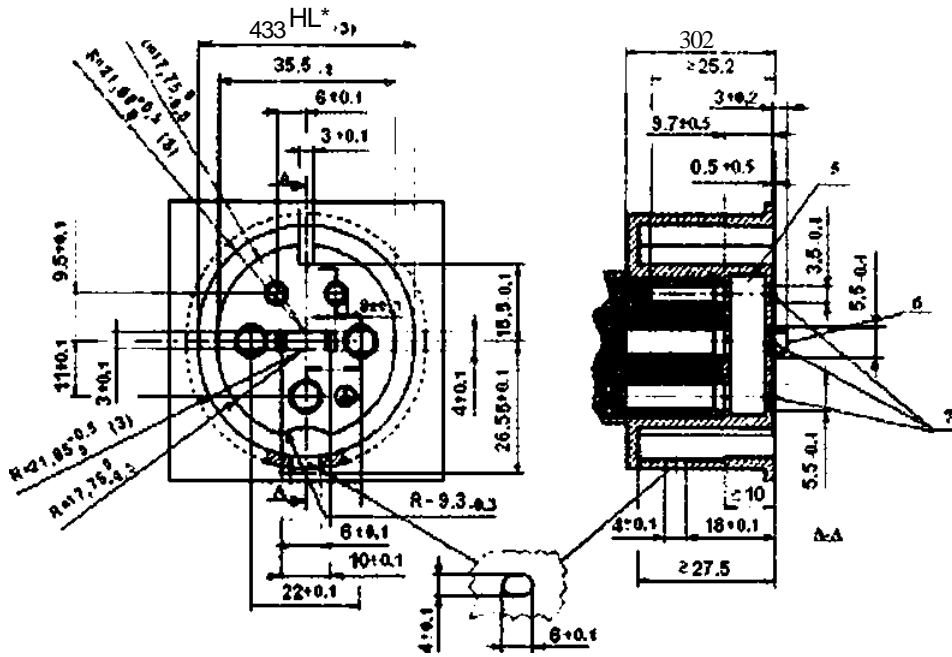

10

()

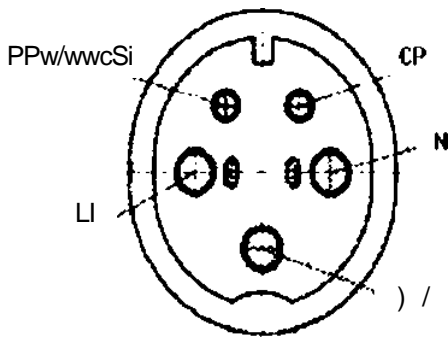

1-

2-

15-

3-

10

5-

6-

7-

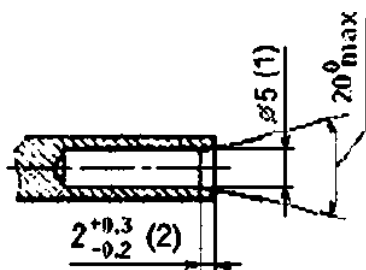

Земля/Фаза/Нейтраль

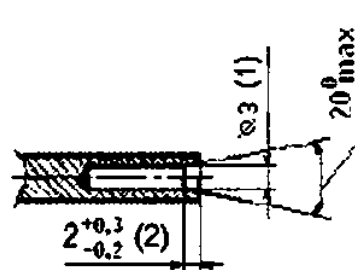

62196-2—2013

2- (3)
2) 250 , 32

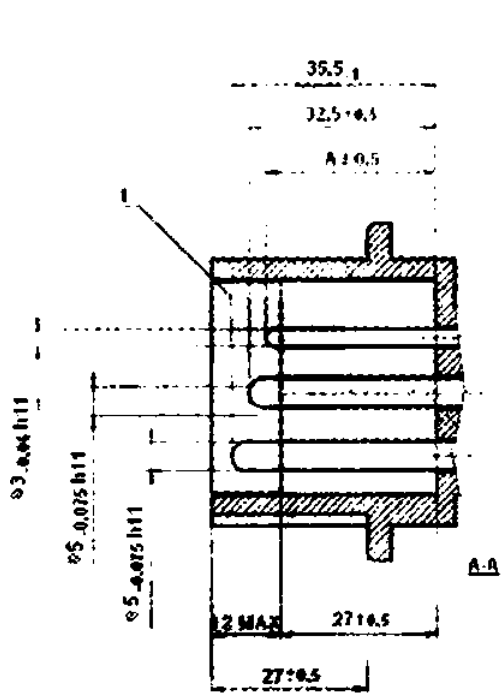

Конец штырей

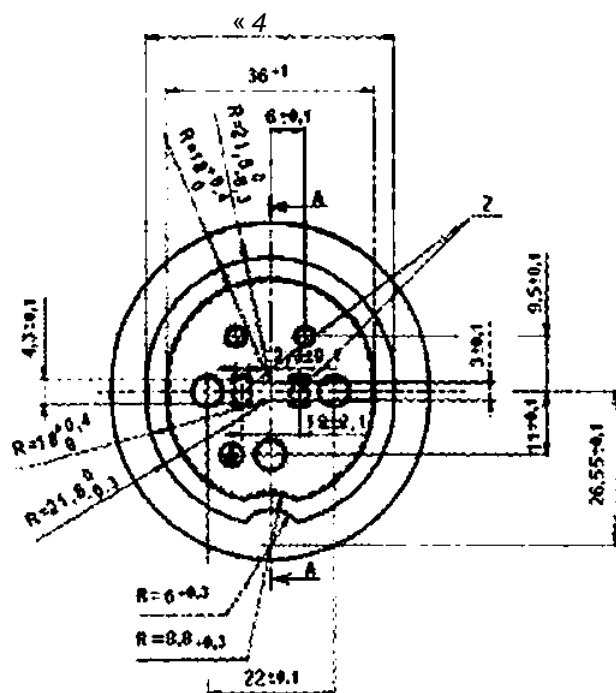

Расположение штырей
()

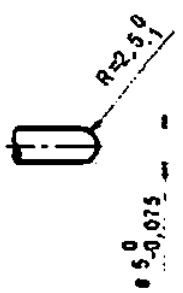

Земля/Фаза/Нейтраль

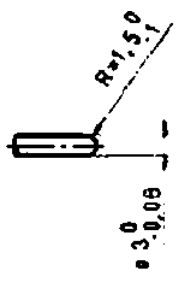

Вспомогательный контакт

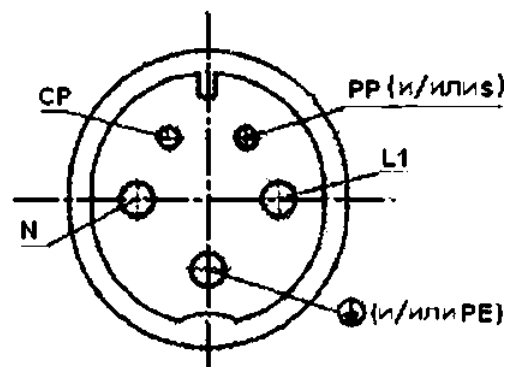

1-
2-

• -29.5 :
• / CS-34

2-IIIb (4)
(3)

250 , 32

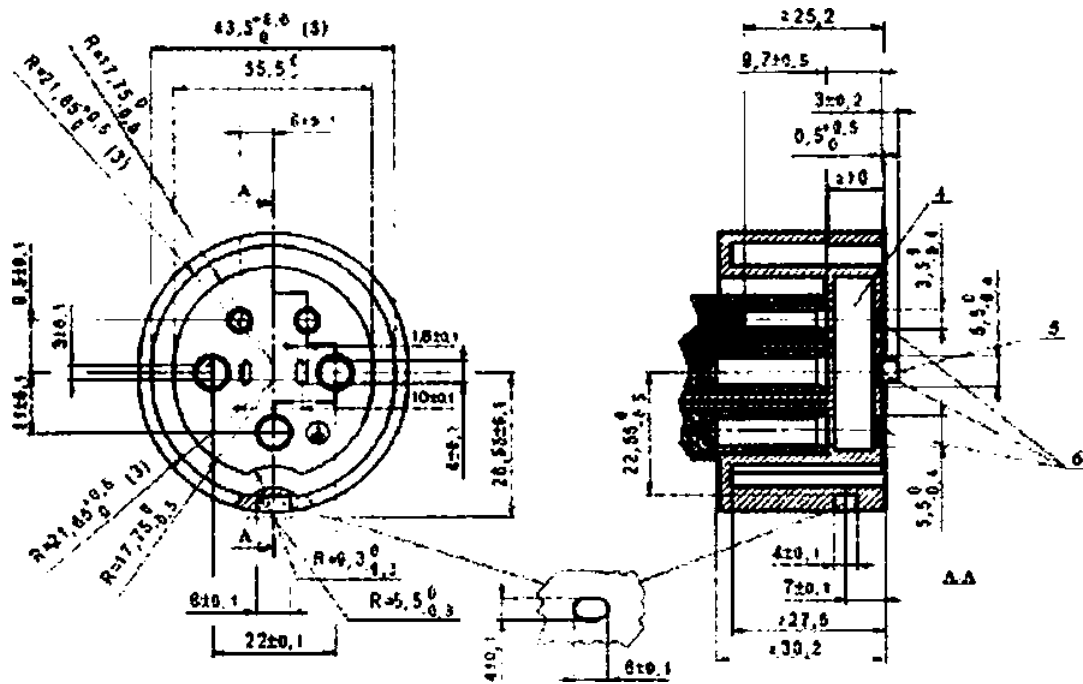

10 ()

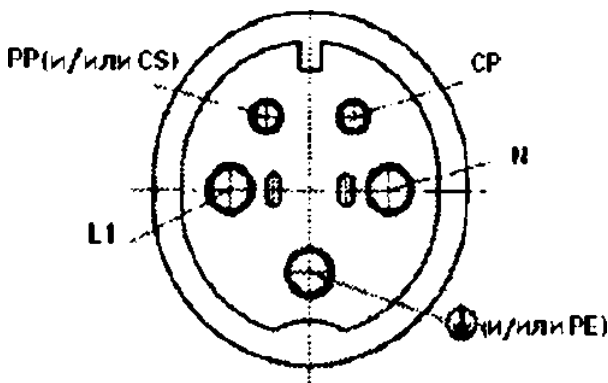

- 1-
- 2-
- 1,5-
- 3-
- 10
- 4-
- 5-
- 6-

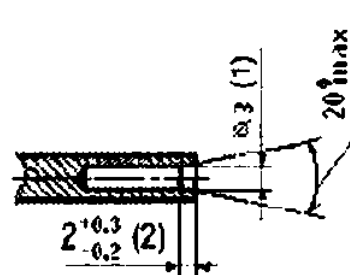
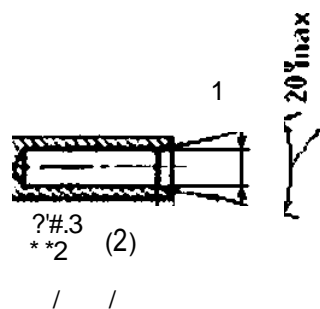

62196-2—2013

2- (1)

480 , 63

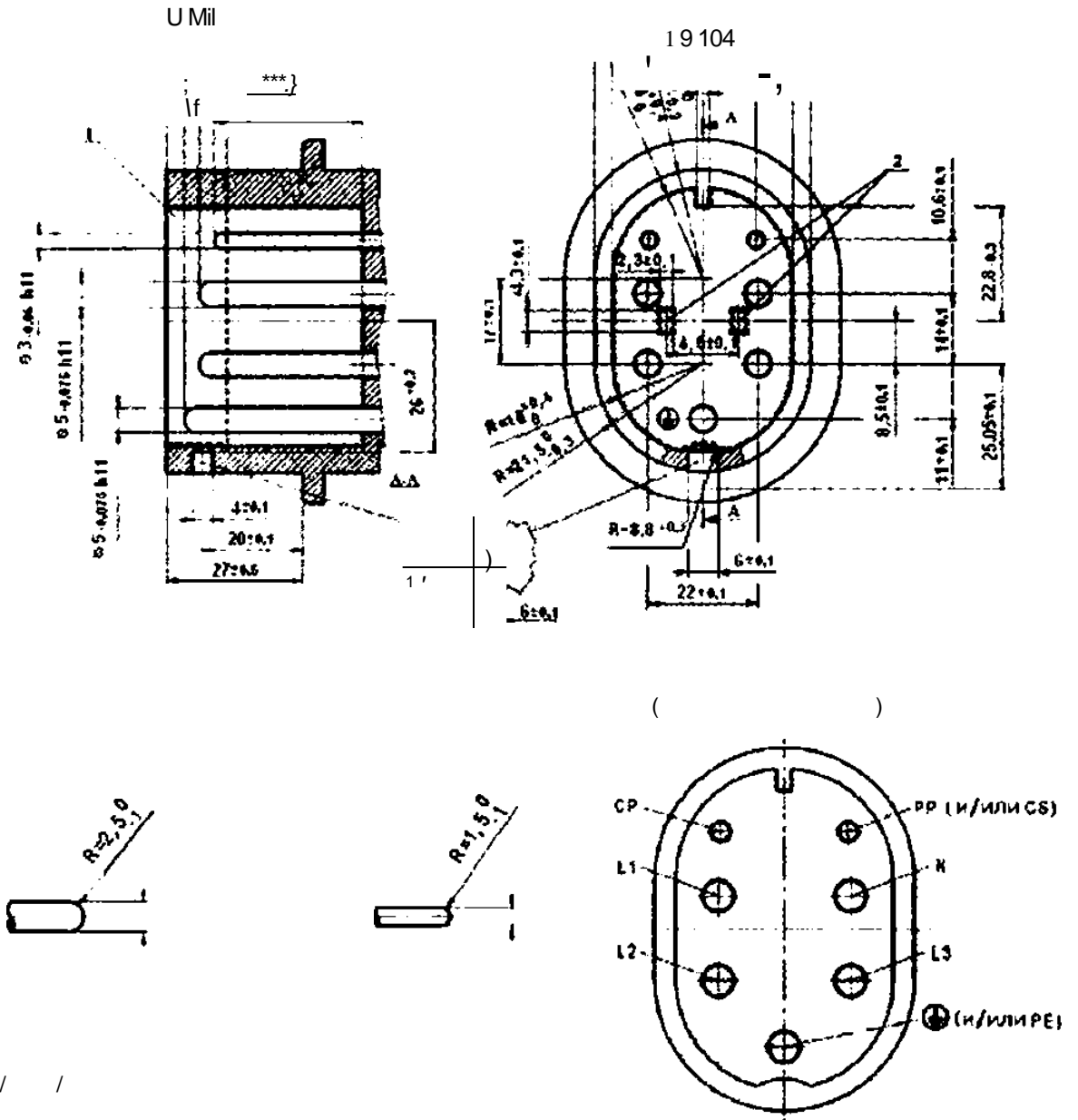

/ /

1-
2-

• -29.5 ;
• / CS-34

2- (2)
(1)

480 , 63

Размеры в мм

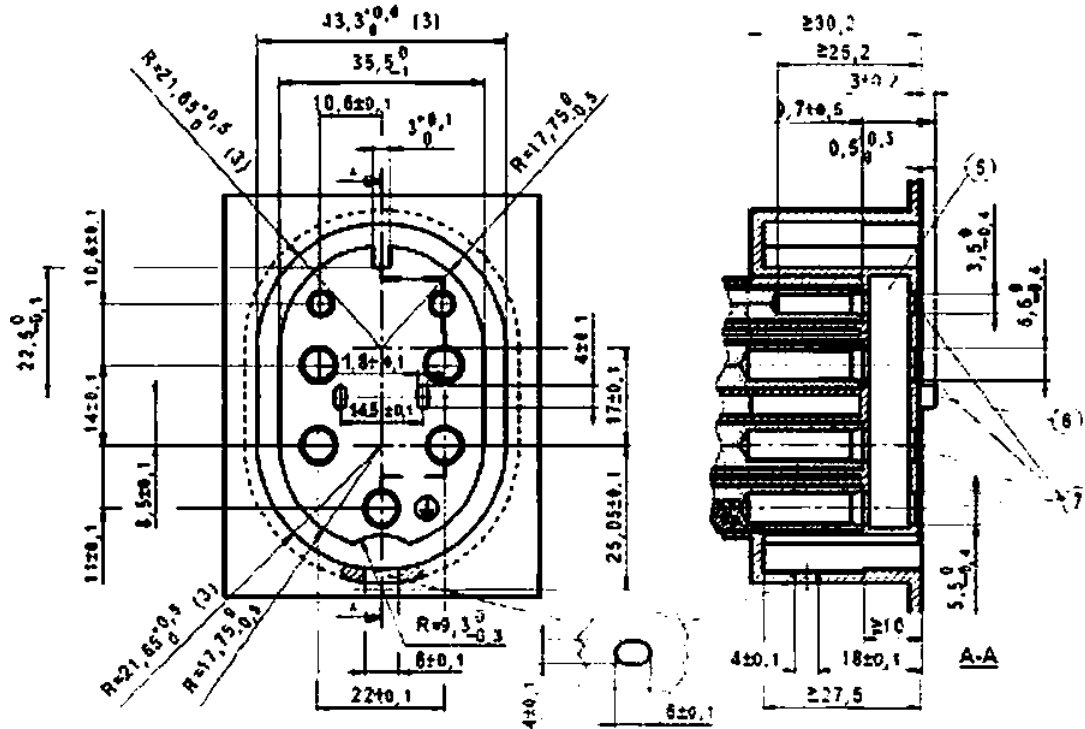

10

()

() »

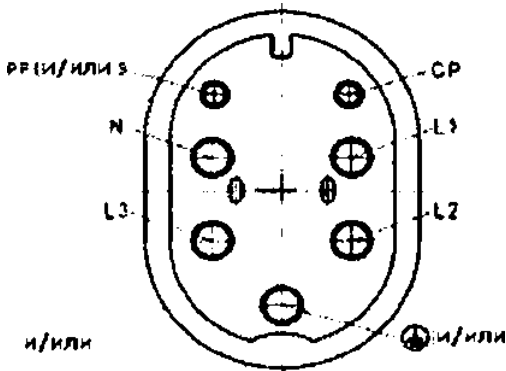

1 -

2 -

1,5-

3 -

10

5 -

6 -

7 -

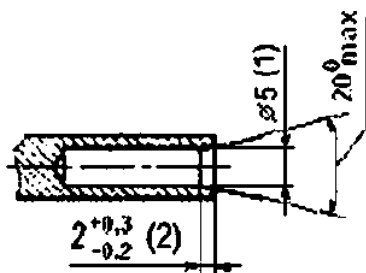

Земля/Фаза/Нейтраль

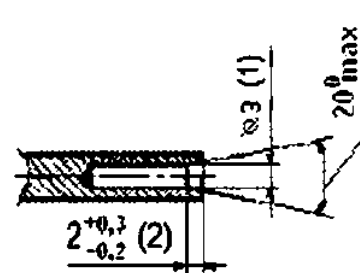

62196-2—2013

2- (3)
(2)

480 , 63

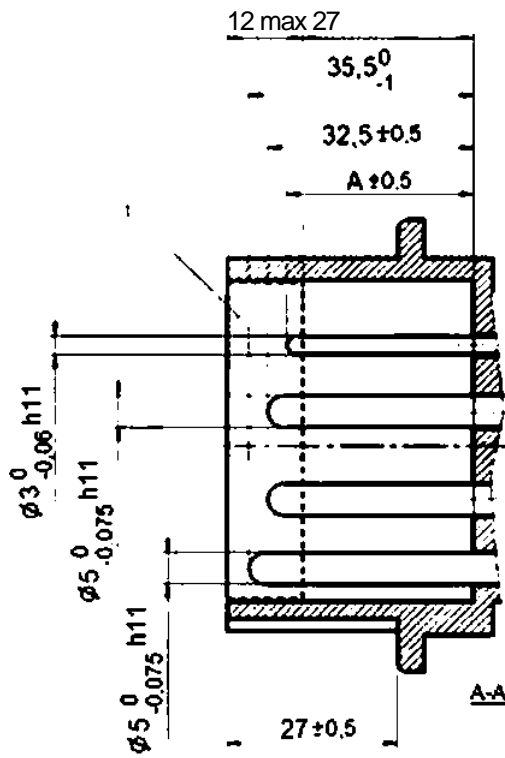

Конец штырей

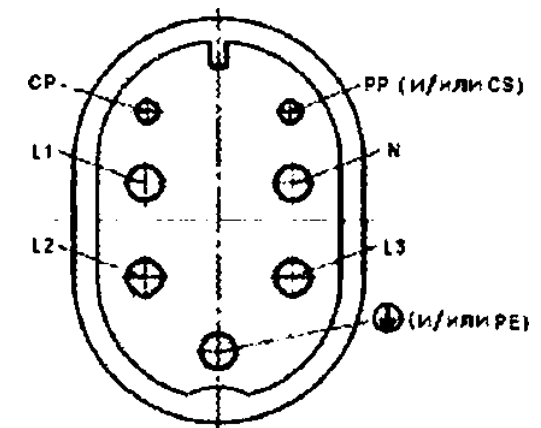
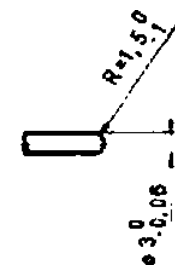
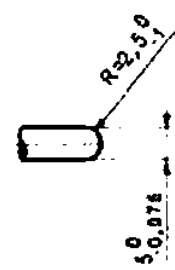
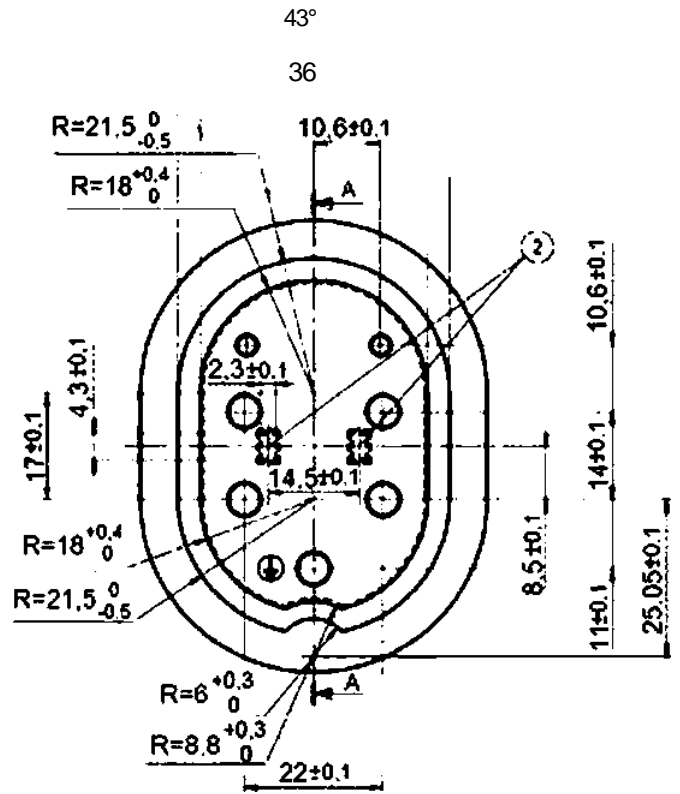

-29.5 ;
/ CS-34

2- (4)
3)

460 , 63

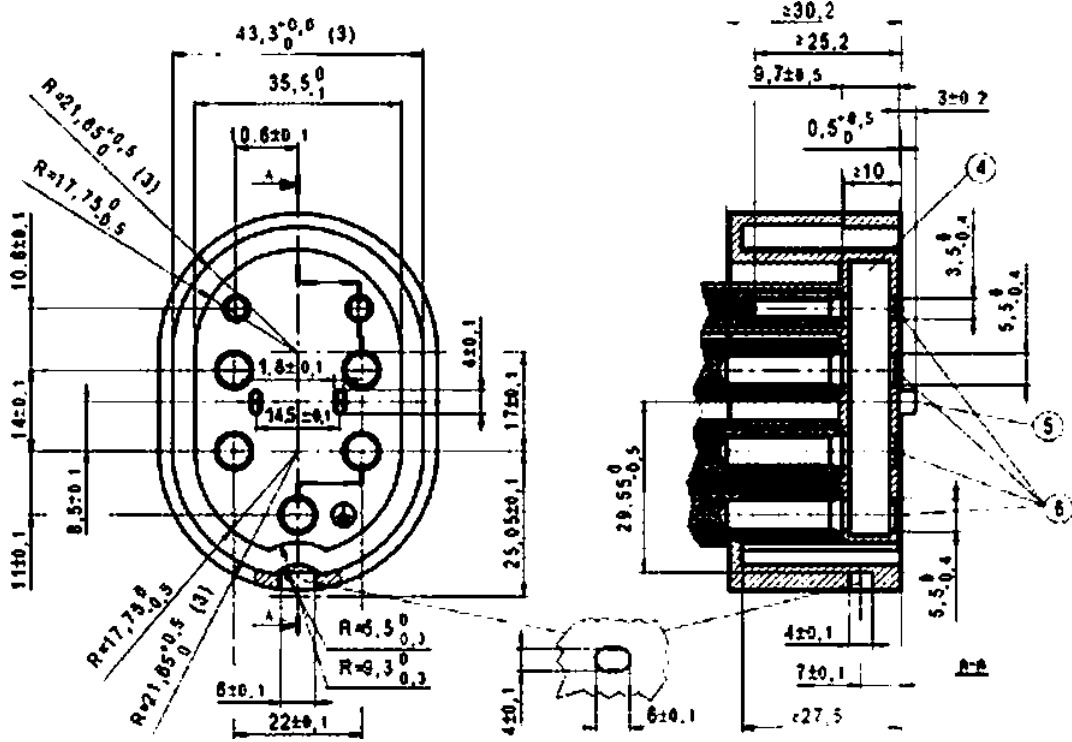

10 ()
()

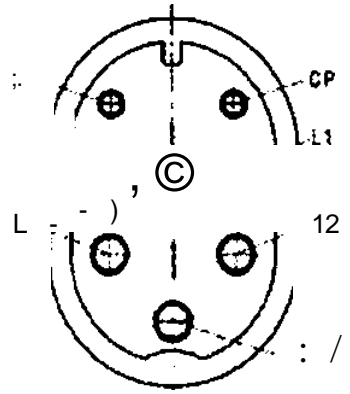

1-
2-
3-
4-
5-
6-
1.5-
10

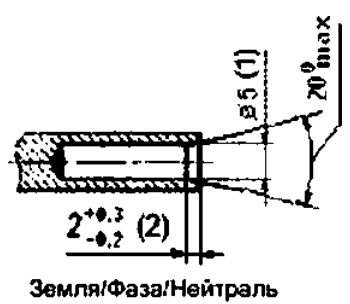

Земля/Фаза/Нейтраль

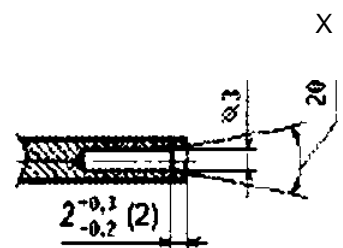

X

62196-2—2013

2-III d (1)

250 , 16

(2*)

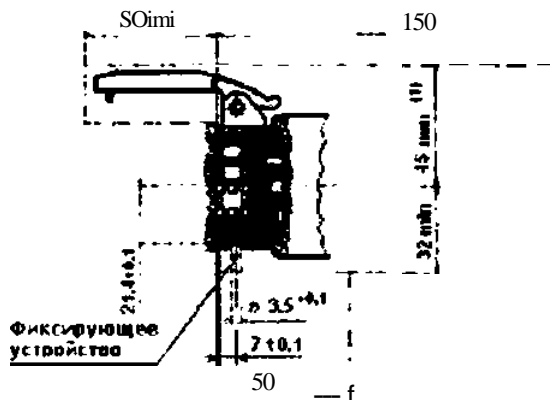

(

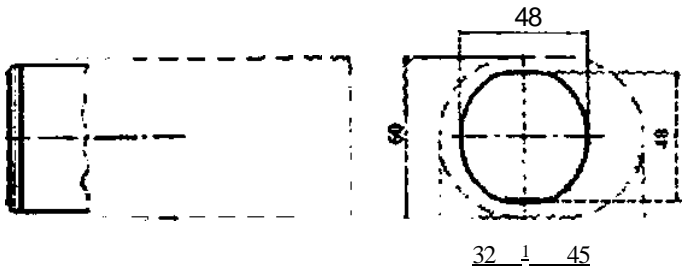

2 + +
250 , 16

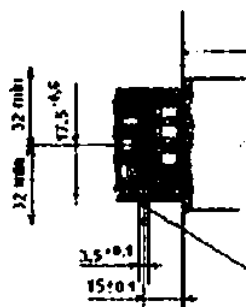

150

1

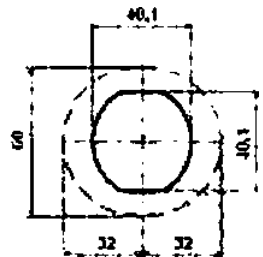
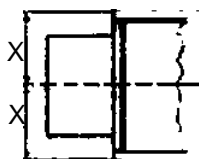

2 + + 1
250 , 16

2-III d (2)
(1)

250 , 32

2-II b)

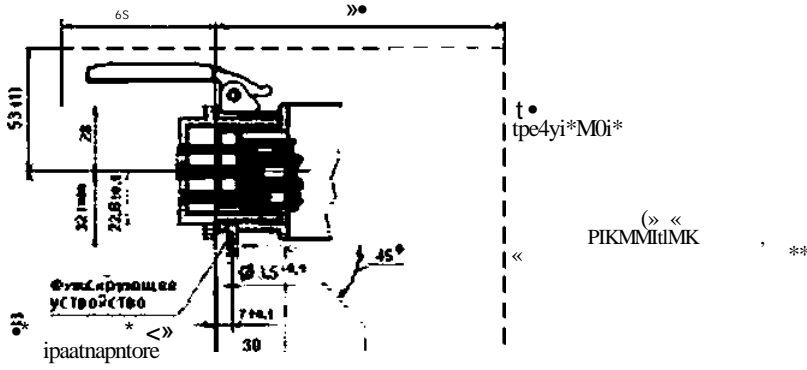

» < < * »

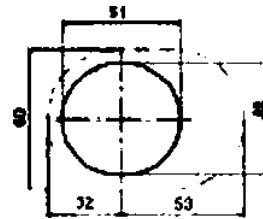

2 + +2
250 , 32

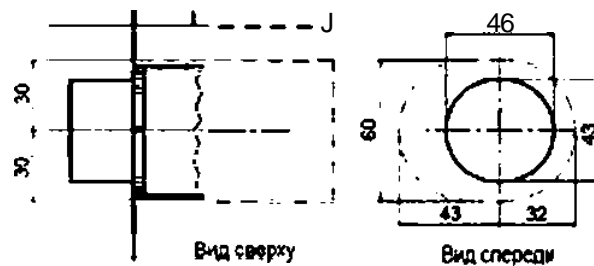
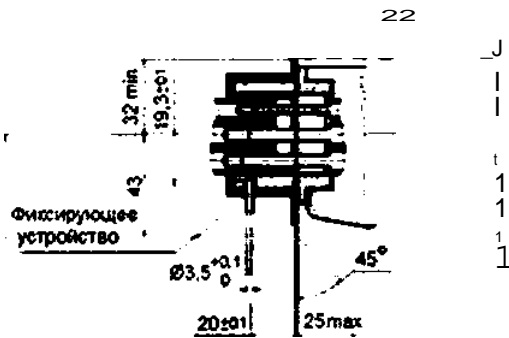

Вид сверху
2 + +2

250 , 32

62196-2—2013

2-III d (3)
(2)

480 , 63

(2-)

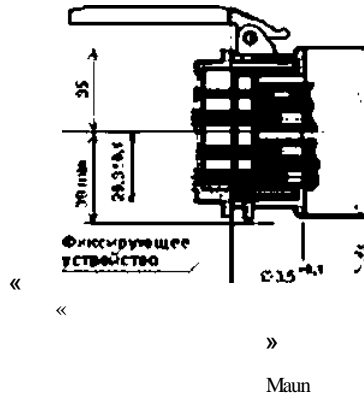

«
! DDM rpa CIM,
* <1 >
ipancnopmore

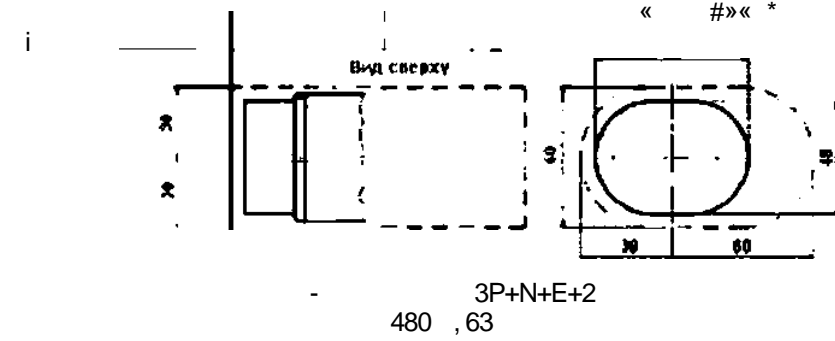

Крпус >viM,
* } *
«< <

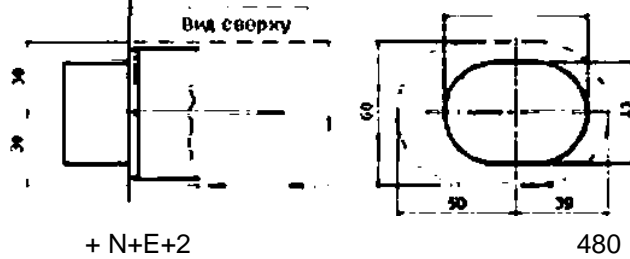

()

()

.1

60068-2-14	MOD	28209-89 - N: 2.
61851-1:2010	IDT	61851-1-2013 1.
62196-12011	IDT	62196-1-2013 TM 1:
<ul style="list-style-type: none"> • MOD- 		

62196-2—2013

621.316.542:006.354

43.040.10

£71

346400

: , , ,

01.09.2014. 60x84/ .
. . .6.51. 36 . .3289.

,

« »

123995 , .. 4.
www.gostinfo.ru info@90stinfo.ru