



HANDHELD MEASURE DEVICES
WATER ANALYSIS



Handheld measuring devices
for water analysis.

Get a handle on water measurement.

Editorial. Specialists by Competence.

'2/3 of the Earth's surface is covered with water. Water is the basis of life. Physical, chemical and biological influences change the water, which, in turn affects us and our environment. Handheld measuring devices from Greisinger help you to better understand water in detail with objective measurements. Our wide assortment of devices gives you the opportunity to evaluate and sustainably use the vital resource with precise measurements.'



Jürgen Brass
Product Manager, Greisinger

GREISINGER
Member of GHM GROUP

A stylized, handwritten signature in black ink, appearing to read 'J. Brass'.

Additional information is provided on our website at:
<https://www.ghm-group.de/branchen/wasser>

 **GHM GROUP**



Dear readers,

Water is a part of our everyday existence and is far more than H₂O. The quality of water is of essential importance to us and the smallest amounts of substances are often sufficient to fundamentally alter the water.

Usually, when looking at water, you do not see that which is contained in detail. Our senses suffice for an initial subjective impression. For an exact and constant evaluation, however, the use of measuring technology is indispensable.

Our handheld measuring devices with reliable sensors are the first choice when it comes to quickly recognizing and visualizing essential features of water on site and in the laboratory. They serve as the basis for a safe evaluation of water quality.

Many small details support daily measuring tasks and make our handheld measuring devices an indispensable daily companion. With the continuous development of our devices, we have continuously improved basic

features and functions in order to achieve the best possible suitability for daily use.

Our handheld measuring devices are used daily in numerous applications. They offer the possibility of obtaining an objective evaluation with the delivered data without having to rely in subjective sensory perceptions.

The measuring results allow decision-makers to agree on a measured value and determine the appropriate course of action. This makes us proud.

This brochure should help you gain an overview of our handheld measuring devices for water analysis. We are pleased to offer you this source of information.

Feel free to contact us. We would be happy to assist you in selection of the correct handheld measuring devices.

Welcome to the world of water analysis.

GREISINGER

Member of GHM GROUP

Handheld measuring devices are concentrated and compact measuring technology and their mobility makes them extremely versatile in use. In the process, local application conditions can differ drastically. High demands, such as extreme cost pressure or maximum precision requirements plan an important role.



Get a handle on water measurement.

Clarity on site.

Greisinger offers you an optimized portfolio of handheld measuring devices and accessories. Decide for yourself which measuring device class is right for you. The entry-level series G 1000, the reference class GMH 3000 or our waterproof premier devices of the GMH 5000 and G 7500 series.



| | |
|---|----|
| Editorial | 3 |
| Overview | 5 |
| The main features of our devices | 7 |
| Areas of application | 9 |
| Measuring processes | 11 |
| G 1000 series | 12 |
| GMH 3000 series | 14 |
| GMH 5000 series | 16 |
| G 7500 multi-parameter device | 18 |
| Basics, conductivity measurement | 20 |
| Basics, pH measurement | 22 |
| Basics, pH electrodes at a glance | 24 |
| Basics, oxygen measurement | 26 |
| Handhelds at a glance | 28 |



The main features of our devices

Very long battery life

Whether with regular use or disuse for months at a time, our handheld measuring devices are always ready to use, thanks to the long battery life. Constant replacement of batteries is a thing of the past.

Ergonomics

Our devices are optimized for easy handling – when you pick up one of our devices, it will feel like it was made just for you. Should you drop a device despite the grippy housing, its robust design assures that it will still work. Many of our devices are waterproof. The device will not be damaged or lose any data even if it is dropped into water.

Precision

We only use carefully selected high-quality components for our measuring devices. Our production achieves the highest level of quality.

With the perfect combination of qualified experts, optimized production equipment and methods, the whole measuring device is far greater than the sum of the parts.

Reference

Each individual device is meticulously harmonized with traceable references during the production process. Almost all devices are provided with verification in the form of an individual test report included in the scope of delivery. Additional calibration services from our calibration laboratories can be combined ex works – and we can offer these services on a recurrent basis, as well.

This traceability and verification are basic requirements for one of the most important areas of application of our devices: to be the traceable reference in quality management according to ISO 9001.

Get a handle on water analysis.

Everything for a good result.

Availability of clean water is one of the most important basic prerequisites for healthy life on our planet. Not only is it a vital basic source of nourishment, it is also a raw material of enormous importance for agriculture, industry and numerous other sectors.

We offer a proven selection ranging from universal devices with a wide area of application to tailored solutions for special applications. We support you with advice and service on your way to reliable measurement.



Handheld measuring devices.

Ready for use - quickly and flexibly.

Simply switch it on. Time is one of our most valuable resources. Careful selection of components and logical factory pre-settings ensure effective time savings – from unpacking to the first measurement in your application. For this purpose, refer also to our interesting 'ready to test' complete offering.



Water is everywhere.

Special devices for your requirement.

Diverse areas of application



Surface water

Regular measurements cover critical changes reliably (e.g. for waste water, sewer systems, swimming pools, etc.). This guarantees safety and the prevention of negative effects.

Drinking water

Along with the air that we breathe, drinking water is our most vital source of nourishment. Monitoring with measuring technology is a logical and efficient way to protect our health.

Process water

Water in large quantities plays a crucial role in numerous industrial processes (e.g. for boiler water, cleaning processes and reverse osmosis). In this connection, handheld measuring devices achieve cost reduction and quality assurance.

Aquariums

Suitable for hobby or large aquarium applications. We want to keep our fascinating underwater friends healthy in order to be close to their aquatic world.

Food

Taste and quality account for the value of food for us. Handheld measuring devices at important measuring points are indispensable during production and storage. They are a basic requirement to be able to guarantee consistent quality and thus safe food.

Agriculture

Water is one of the fundamental elements of plant growth, whether in the field, the greenhouse or in the garden. An exact soil analysis with water analysis instruments helps to promote growth processes while saving costs and relieving the environment. For example, the application of fertilizer can be purposefully controlled or the optimal fertilizer utilization by the plants can be enabled by influencing the pH value of the soil.

Handheld measuring devices.

Measuring technology as a source of safety.

Our experts develop tailored mobile measuring applications for on-site water analysis. Every one of our series of measuring devices combines the advantages of mobile use with the reliability and precision of a stationary process measuring device. We offer suitable sets in order to simplify the combination of devices and accessories. The device and accessories are included in a measuring case and combined with a price advantage over the individual parts.



Experts for water analysis.

Determine values quickly and safely.

Handheld measuring devices from Greisinger



Measuring processes

The widest variety of measuring processes is used for water analysis.

- electrochemical measurement
- photometry/ turbidity measurement
- chemical measurement with indicators (droplets, paper strips)
- optical measurement

The handheld measuring devices from Greisinger are focussed on the three classical electrochemical measurements.

- pH/ Redox
- dissolved oxygen
- conductivity/ salt content

Electrochemical measurement with handheld measuring devices from Greisinger offer the following advantages over other measuring processes:

Direct on-site measurement

Measurements are displayed directly and conveniently.

Example: oxygen measurement in bodies of water can be used to determine individual values or a 'profile' of oxygen concentration on site. Therefore, no elaborate sampling or additional laboratory work is necessary.

Affordable standard measurement

Our new G 1000 series offers you easy-to-operate measuring devices. The devices are low-maintenance and suitable for everyday use – even inexperienced users will quickly learn how to handle them. With regular use, handheld devices from Greisinger achieve cost savings in each measurement.

Exact measurements

High precision is beneficial when determining pH and conductivity values.

For example, traceable conductivity measuring devices or pH buffer solutions are required when testing in-line measuring technology on site in the scope of quality assurance processes.

In addition to numerous handheld measuring devices, the GHM GROUP also offers additional measuring technology solutions in this area.

- laboratory measuring technology in control panel units (Delta OHM)
- industrial sensors, measuring transducers and indicators (Martens and Greisinger)
- turbidity measurement (Martens)



G 1000 series

The primary focus in the development of the new G 1000 series was placed on the essential functions of the measurement technology. Pure measurement with a focus on precision, speed and reliability combined with a compact housing enables an impressive price/performance ratio.

The handheld measuring devices also impress with the ergonomic design, dust and water-protected design according to IP 65/67 and the illuminated display.

The G 1000 series with test reports redefines our entry-level measuring technology class. Equipped with low-maintenance sensors, the G 1000 of easy-to-operate precision measurement devices in a handy format is designed to offer you reliable service for years to come.

Advantages

- ergonomic and functional housing, grippy and operable with one hand
- large and easy-to-read 3-line LCD display
- overhead view at the push of a button
- with backlighting, so it can be read in total darkness or bright daylight
- robust and waterproof according to IP65/67
- high availability for use with long battery life – easy battery replacement with easy-to-purchase standard batteries
- high-quality and affordable sensors
- purposefully selected sensors ensure low-maintenance use – always keep costs and work under control
- devices are also available in practical sets
- professional measuring technology for an entry-level price
- Made in Germany

G 1000 series.

Pure & tireless measurement.

Innovative compact measuring devices



G 1410, EC meter G 1700, thermometer



G 1610, oxygen

Application areas

- freshwater and salt water aquariums
- reverse osmosis and similar filters
- cleaning processes
- cooling/ lubricating processes
- plant husbandry and agriculture
- laboratories
- quality assurance
- service



G 1500, pH meter





The proven reference class

A large assortment of variants and wide selection of sensors and accessories ensures a solution exactly for your application. The comprehensive functions make the GMH 3000 series flexible in use for the widest variety of measuring tasks. Complete sets with universal sensors are also available.

All of the measuring devices for pH/ Redox (GMH 3500), conductivity/ TDS/ salinity (GMH 3400) and oxygen concentration (GMH 3600) are available in various functional versions. In the process, the same high-quality measuring technology is included in every variant of the respective measured variable: Optimized and power-saving precision measuring inputs.

You choose the functionality according to your requirements and only pay for what you actually need. In the process, available equipment features include:

- Data logger with up to 1000 values at the push of a button or up to 10,000 values automatically.
- Interface for measurement detection on the PC or for evaluation of logger data with the evaluation software GSOF 3050.

The interface adapters for USB and RS323 are galvanically isolated – this minimizes widespread practical problems with measurement in processes with earthed tanks. Analogue output 0–1 V – for connection to the printer with alarm buzzer if the display is not in view.

Advantages

- different equipment variants of devices – individually combinable for your requirements
- interface for data recording directly on site is always possible with Easy Control or EBS 20M software
- the support enables convenient reading of measurements
- best-in-class price/ performance ratio
- additional devices in the series for temperature, pressure, material humidity and oxygen are available – a comprehensive device concept that goes well beyond water analysis

GMH 3000 series.

Professional standard.

Flexible for your application



GMH 3531

Application areas

- freshwater and salt water aquariums
- reverse osmosis and similar filters
- cleaning processes
- measurements in boiler feed water and heating water
- adiabatic humidification and cooling processes
- cooling/ lubricating processes in machining
- food: milk, cheese, meat, e.g. with special insertion electrodes
- plant husbandry and agriculture
- laboratories
- quality assurance
- service





Performance and durability

The GMH 5000 series combines the flexibility of the GMH 3000 devices with the waterproof capability of the G 1000 series.

Therefore, a reliable field measuring device as available for use in unpleasant places: in outdoor use in inclement weather and in darkness, indoors where it is damp and dirty.

The modern and ergonomic design has also been developed for modern laboratory use.

At the same time, the GMH 5000 series can be used in sewage treatment plants of various sizes – the applicability in this case is guaranteed for use in the laboratory and in the field alike.

Advantages

- easy recognition of measurements with large backlit display, in darkness or in bright sunlight
- optimized impact and fall protection, as well as practical handling with a tear-resistant silicone protective cover
- reliable plug connections guarantee a long device service life with high comfort due to bayonet technology
- interface with additional speed (8 times as fast as the GMH 3000 series) for rapid reading of logger devices
- the support enables convenient reading of measurements
- protected from water and weather influences
- floatable device design
- practical sets available, incl. transport case to help maintain order at the measuring point

G 5000 series.

Durable and protected from weather influences.

The reliable partner in demanding field use



GMH 5430

Application areas

- sewage treatment plants
- industry and skilled trades
- measurements in water bodies, aquariums and fish husbandry
- drinking water monitoring
- process monitoring
- soil measurement
- food production and control
- quality assurance
- medicine
- pharmaceuticals
- chemicals



GMH 5630

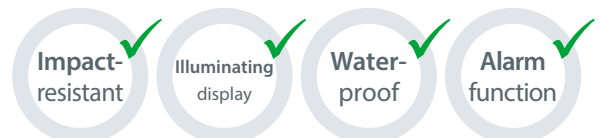



G 7500

A multi-channel measuring device was developed based on our proven G 1000/ GMH 3000/ GMH 5000 individual-parameter devices. This combines multi-channel measurement with the proven housing of the GMH 5000 series.

Numerous applications demand simultaneous measurement of multiple measured variables. For example, simultaneous measurement of pH and oxygen is desired when monitoring bodies of water – the G 7500 determines both measurements in one device.

A very interesting application area for the combination of pH and conductivity is the current trend market of vertical farming/ urban farming.

A daylight-compatible backlit graphic display is used for optimal visualization. At the same time, simple measurement and easy calibration are guaranteed with the plain text display with various language settings. There are no longer any limitations on the measurement recording, because the buffer size of the data logger is very large. Our proven sensor connections are installed in the devices. As a result, system costs are kept in check and the flexibility of the free sensor selection adapted to your emphases is guaranteed.

Advantages

- simultaneous measurement of pH/ oxygen or pH/ conductivity and the corresponding temperatures
- integrated galvanic isolation enables simultaneous measurement with affordable standards sensors
- the display enables convenient reading of several values simultaneously and the measurement curve in diagram form
- the data logger can be read directly via USB – with standard smartphone cable or software
- simple and convenient battery charging via USB connection

Multi-parameter device. Bundled competence of water analysis.

G 7500



Brand-new

Application areas

- monitoring of bodies of water
- drinking water preparation
- sewage treatment plants
- fish husbandry and aquaculture
- vertical/ urban farming
- conventional agriculture



Water analysis.

Basics.

Conductivity measurement

Every conductivity measuring device from our numerous product families has high-quality measuring technology that satisfies the highest precision requirements.

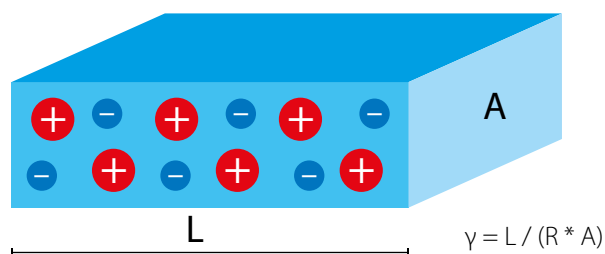

Since the conductivity is a measurement for the ions dissolved in the water, it is also an indirect measurement for concentration or salt content. For precise measurement of salt content in sea water or process fluids, derived variables such as salinity (g salt/kg water) or TDS (mg/l total dissolved solids) can also be displayed for the relevant devices.

Basics:

- the conductivity describes the capability of a material to conduct electrical current
- in liquids, this is an indicator for the contained dissolved ions
- normally used units: mS/cm and μ S/cm
- electrical resistance is measured at the contact surfaces of measuring cells
- the device calculates the conductivity with the geometry of the measuring cells and the corresponding cell constant
- in the process, the conductivity is temperature-dependent
- all devices offer convenient temperature-compensation options, such as VLF or linear
- the measuring cells have precise integrated temperature sensors

Examples for conductivities:

| liquid | Conductivity |
|------------------------------|------------------------|
| Boiler feed water | up to 0.2 μ S/cm |
| Ion exchanger | up to 1.0 μ S/cm |
| Rain water | 10 ..100 μ S/cm |
| Drinking water | 100 .. 2000 μ S/cm |
| Sea water | 10 .. 50 mS/cm |
| Industrial process water | up to 500 mS/cm |
| Concentrated acids and bases | up to 1000 mS/cm |

Water analysis.

Basics.

Conductivity measurement

The conductivity measurement covers numerous magnitudes. We offer the right measuring cells for your application.

| | LF 200 RW | LF 210 | LF 202 |
|-----------------|--|---|---|
| Type | 2-pole stainless steel | 2-pole glass/ platinum | 2-pole graphite |
| Application | Clean/ purest water | Alcohol, benzine, diesel, paint | Surface and drinking water |
| Feature | Corrosion-proof with media-compatible materials PEEK and stainless steel | Easy to clean with platinum electrodes; also suitable for higher conductivity | Low-cost introduction for lower and higher conductivity |
| Measuring range | 0 .. 200.0 μ S/cm *) 0 .. 100.0 μ S/cm | 0 .. 1000 μ S/cm | 0 .. 15.0 mS/cm *) 0 .. 200.0 mS/cm |
| GMH 5430/-50 | x *) | x *) | x *) |
| GMH 3431 | | | solid |
| GMH 3451 | | | |
| G 1410 | | | solid |
| G 1420 | solid | | |
| G 7500 | | | x *) |

| | LF 400 | LF 425 |
|-----------------|--|--|
| Type | 4-pole graphite | 4-pole graphite |
| Application | Universal wide-range | Precision wide-range |
| Feature | With 4-pole technology, it is especially well-suited for low and high conductivity | With 4-pole technology and special graphite, it is especially precise for lower and the highest conductivity |
| Measuring range | 0 .. 200.0 mS/cm | 0 .. 1000 mS/cm |
| GMH 5430/-50 | x *) | x *) |
| GMH 3431 | | |
| GMH 3451 | solid | |
| G 1410 | | |
| G 1420 | | |
| G 7500 | x *) | x *) |
| | | |

*) interchangeable: Choose the right measuring cell for your device and application or, alternatively, one of our set offers including sensors

Water analysis.

Basics.

pH measurement

Definition of the pH value

The pH value describes the acidic or alkaline (basic) character of an aqueous solution.

- a low pH value indicates a higher concentration of H⁺ ions (hydronium ions)
- a high pH value indicates a low H⁺ ion concentration

What is an acid or a base?

- definition of an acid:
an acid can split a hydronium ion H⁺
- definition of a base:
a base can split a hydroxide ion OH⁻.

In neutral liquid (pH = 7), H⁺ and OH⁻ balance out (neither acidic nor basic).

Definition of the pH scale

The pH value is the negative logarithm of hydronium activity (simplified: concentration).

$$\text{pH} = -\log_{10} a(\text{H}^+)$$

The ion product of hydronium ions and hydroxide ions is constant in aqueous solutions at 25 °C.

$$\begin{aligned} a(\text{H}^+) * a(\text{OH}^-) &= 10^{-14} \\ \text{or} \\ \text{pH} + \text{pOH} &= 14 \end{aligned}$$

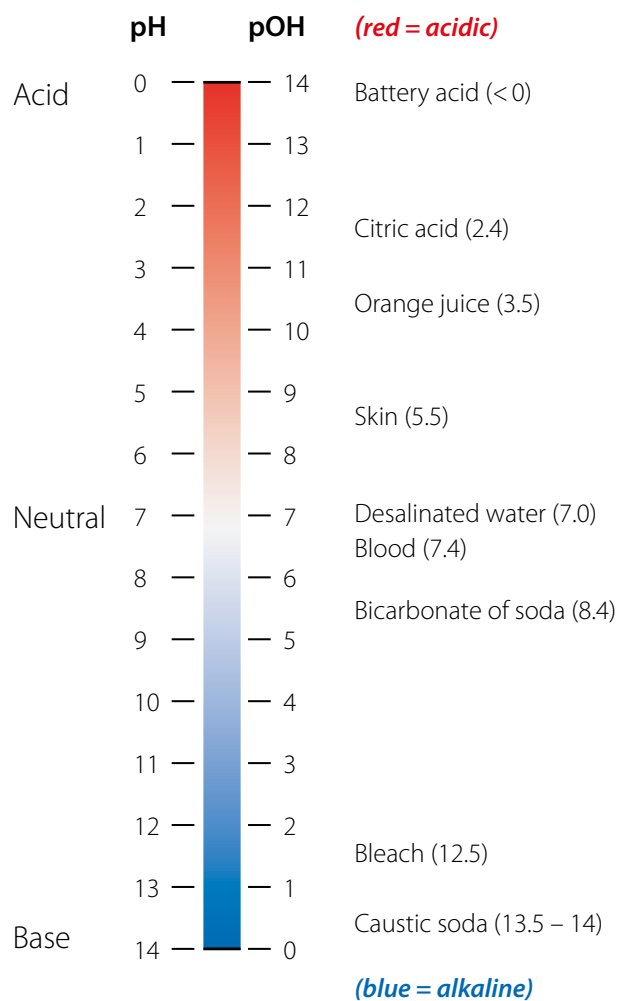

Water analysis.

Basics.

Principle of a pH electrode

The pH electrode

A so-called single-rod measuring chain is normally used as an electrode. This measures a voltage in aqueous solutions and is sometimes also used in foods such as cheese and meat.

- the voltage is proportional to the pH value
- $U_m = U_1 + U_2 + U_3 + U_4 + U_5 =$
(pH value – zero point) × gradient

Due to the fact that pH signals are very weak (high-ohm), it must be ensured, in particular, with the pH value that long cables and soiling of the plug connections are avoided.

The minimum conductivity should be available for stable measurements.

The voltage output is pH 7 : 0V and is almost linear with a gradient ideally of -59.2 mV/pH (in practice, $-50 \dots -59.2 \text{ mV/pH}$).

We offer calibration fluids and cleaning solutions.

The temperature for the pH measurement

The temperature is important for various functions. Our devices offer convenient compensation functions – so they can measure safely and conveniently in practice

- the voltage output of the pH electrode is temperature-dependent
- the pH value of liquids is temperature-dependent
- buffer solutions depend slightly on the temperature during calibration

Regular calibration and maintenance

Regular adjustment (calibration) is required for precise measurements. Depending on the accuracy requirement and application, calibration intervals range from 1 time per day to 1 time per year.



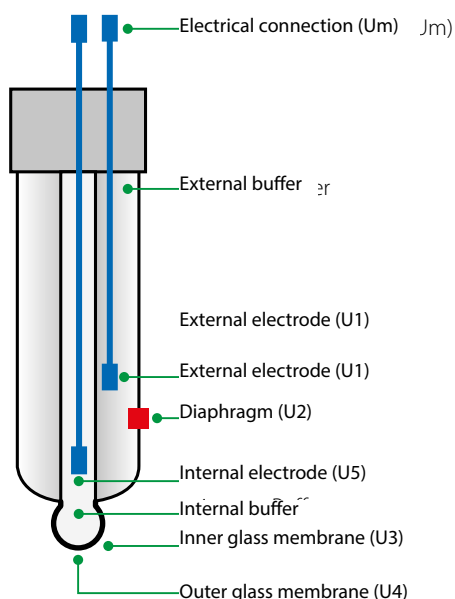

For this purpose, we offer you the right calibration liquids and cleaning solutions.



Water analysis.

pH electrodes at a glance.





A selection of the GE series

| | GE 100 | GE 101 | GE 104 | GE 114-WD |
|------------------------------------|--|--|--|--|
| |  |  |  |  |
| Measuring range | 0 .. 14 pH | 2 .. 11 pH | 0 .. 14 pH | 0 .. 14 pH |
| Temperature range | 0[-5] .. 80 °C | 0 .. 60 °C | 0[-5] .. 80 °C | 0 .. 60 °C |
| Conductivity | >100 µS/cm | >100 µS/cm | >20 µS/cm | >200 µS/cm |
| T measurement | no | no | no | no |
| Waterproof | no | no | no | no |
| Cable | 1 m | 1 m | 1 m | 1 m |
| Electrolyte | 3 mol/l KCL | 3 mol/l KCL | 3 mol/l KCL | Gel-Electrolyte |
| Particular feature | Standard | Small sample volume, 6 mm tip | Cosmetics, low-ionic media | (WP: waterproof) Low-cost, low-maintenance |
| Emphases of the application | | | | |
| Environmental analysis | x | | | x |
| Swimming pool | x | | | x |
| Water preparation, drinking water | x | | | x |
| Sewer | | | | |
| Aquariums, fish husbandry | x | x | x | x |
| Food | | x | | |
| Soil, farming | | x | | |
| Emulsions, suspensions | | x | x | |
| Low-ionic media | | | x | |
| Galvanising, lacquer, paint | | | | |

Since a variety of special electrodes are available for special applications in addition to the universal standard electrodes, the electrodes on our handheld measuring devices are basically interchangeable.

The connection takes place via a robust BNC plug connection; with the G 1000 and GMH 5500 series, this can even be waterproof.



| | GE 120 | GE 125 | GE 151 | GE 171 |
|--|--|--|--|--|
| |  |  |  |  |
| Measuring range | 0 .. 14 pH | 0 .. 14 pH | 0 .. 14 pH | 0 .. 14 pH |
| Temperature range | 0 .. 80 °C | 0 .. 70 °C | 0 .. 80 °C | 0[- 5] .. 80 °C |
| Conductivity | >200 µS/cm | >200 µS/cm | >100 µS/cm | > 50 µS |
| T measurement | no | Integrated Pt1000 | no | no |
| Waterproof | no | yes (IP67) | no | no |
| Cable | 1 m | 2 m | 1 m | 2 m |
| Electrolyte | KCL/AGCL gel | Gel-Electrolyte | 3 mol/l KCL | Gel-Electrolyte |
| Particular feature | Insertion electrode, tip 13 x 60 mm, stainless steel knife, meat, cheese, etc. | Temp.-compensated, interchangeable, waterproof IP67 | Chemically-resistant glass shaft | Process chemistry, biochemistry, alkaline-resistant |
| Emphases of the application | | | | |
| Environmental analysis | | x | | x |
| Swimming pool | | x | | |
| Water preparation, drinking water | | x | x | x |
| Sewer | | | | x |
| Aquariums, fish husbandry | | x | x | |
| Food | x | | | |
| Soil, farming | | | x | |
| Emulsions, suspensions | | | | |
| Low-ionic media | | | | |
| Galvanising, lacquer, paint | | | x | x |

Water analysis.

Basics.

Oxygen measurement

Dissolved oxygen in water

Dissolved oxygen is the basis for many life forms in water: fish, crustaceans and micro-organisms are all dependent on an adequate oxygen content of the water. Measurement of the oxygen, therefore, is beneficial for professional aquaculture and for monitoring of surface water, sewage treatment plants and well water.

Example: oxygen concentration/ saturation over 8 days of Sun in a flowing body of water.

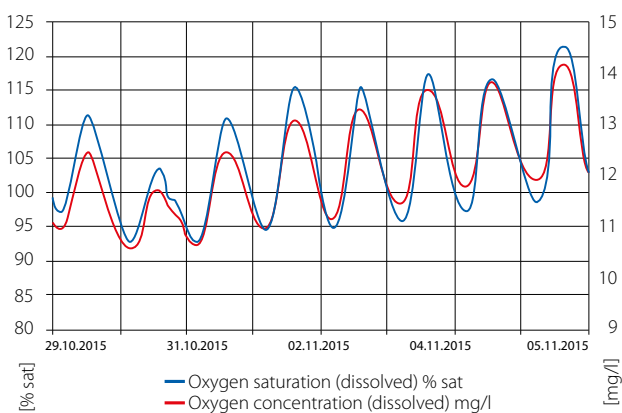

Oxygen is absorbed at the boundary between the water surface and the atmosphere. It is also produced by the metabolism of healthy water plants and algae with adequate light radiation (photosynthesis).

Animals and other life forms and decaying processes and the degradation of nutrients are oxygen-consuming. Water can assume different amounts of oxygen – cold water significantly more than warm water, fresh water significantly more than salt water.

The measured variables saturation and concentration

Two measured variables offer a good illustration of the oxygen conditions in water:

1. Oxygen saturation

Oxygen dissolves in moving water from air oxygen on the water surface. Since the oxygen content of the air is nearly constant (~20.9 vol. %), the maximum natural saturation value is defined as 100 % sat. A value of 20 % sat indicates: 4/5 of the theoretically dissolvable oxygen has already been consumed and the oxygen level is low.

2. Oxygen concentration

The oxygen concentration describes the absolute amount of dissolved oxygen in milligrammes of oxygen per litre of water (sometimes specified as ppm, 1 mg/l = 1 ppm).

Water analysis.

Basics.

Oxygen measurement

The solubility of oxygen

Since the solubility of oxygen is temperature-dependent, the corresponding oxygen concentration with 100 % sat is also dependent on the temperature.

Temperature (°C) O₂ concentration

(mg O₂/l with 100 % sat and 1013 mbar)

| | |
|----|-------|
| 0 | 14.16 |
| 5 | 12.37 |
| 10 | 10.92 |
| 15 | 9.76 |
| 20 | 8.84 |
| 25 | 8.11 |
| 30 | 7.53 |

This makes it clear that only limited amounts of oxygen are permanently available, particularly with bodies of water having a high nutrient content (phosphate and nitrate) and high temperature (e.g. above 25 °C).

A body of water with various areas having different oxygen concentrations

Normally, layering plays a role in deep bodies of water: Many degradation processes take place at the bottom, in its sludge, where there is less light for photosynthesis. At the same time, the oxygen absorbed at the surface has a long path to the bottom. In many bodies of water, there are separate areas near the bottom of the body of water in which there is no oxygen at all.

Additional applications

Oxygen is not always positive: oxygen can have a corrosive effect in pipeline systems and should be avoided (well water / drinking water). The same applies for boiler feed water or heat exchangers.

Oxygen measurement and sensors

Oxygen measurement with our handheld measuring devices is carried out with galvanic sensors. In these sensors, oxygen is consumed at the diaphragm on the front side in order to generate an electrical current which is proportional to the dissolved oxygen in the water.

For exact measurement, a small flow on the diaphragm is optimal, e.g. with the raising and lowering of the sensor in the water during the measurement.

With regular maintenance, the affordable sensors can be operated for several years, while the diaphragm and electrolyte are exchangeable.

Long cables are also available for depth measurements directly on site. As a result, elaborate sampling on site and falsification due to temporally delayed evaluations.

Handheld measuring devices.

Measuring devices and measured variables at a glance.

G 1000 series, GMH 3000 series and GMH 5000 series





An overview of water analysis devices

Our water analysis devices reflect the current state of the art and support you in measuring numerous measured variables.

Only high-quality input amplifiers and sensors are used. In the process, automatic temperature compensation is standard equipment for almost all devices.

The optional traceability with our service offering is of particular interest for quality assurance processes – optionally with ISO calibration certificates or with DAkkS calibration certificates.







As proof of the high precision ex works, a test report is included with delivery of the product, free of charge.

| | G 1410 | G 1420 | G 1500/ G 1501 | G 1610 | GMH 3511/ 3531/3551 |
|---------------------------|---|---|---|---|---|
| |  |  |  |  |  |
| Measured variables | | | | | |
| pH | | | ● | | ● |
| Redox | | | ●(G 1501) | | ● |
| Dissolved oxygen | | | | ● | |
| Conductivity | ● | ● | | | |
| Salinity PSU | ● | | | | |
| Spec. resistance | | ● | | | |
| TDS concentration | ● | | | | |

Water analysis devices in the set

In addition to individual devices and sensors, we also offer practical sets with price advantages – specifically for mobile use, the set cases provide practical protection and keep your valuable devices and help maintain order.



| | GMH 3611/ 3651 | GMH 3431/ 3451 | GMH 5530/ 5550 | GMH 5630/ 5650 | GMH 5430/ 5450 | G 7500 |
|---------------------------|---|---|---|---|---|---|
| |  |  |  |  |  |  |
| Measured variables | | | | | | |
| pH | | | ● | | | ● |
| Redox | | | ● | | | ● |
| Dissolved oxygen | ● | | | ● | | ● |
| Conductivity | | ● | | | ● | ● |
| Salinity PSU | | ● | | | ● | ● |
| Spec. resistance | | ● | | | ● | |
| TDS concentration | | ● | | | ● | |

Your contact to us.



Sales Center Export

 info@ghm-group.de

 +49 2191 9672-0

 +49 2191 9672-40



Asia and India

- Subsidiary in Mumbai
- Numerous certified partners



Europe

- 12 locations, including sales centers
- 5 production locations and specialized sales locations



Americas

- Subsidiary in São Paulo
- Qualified partners



Africa

- Subsidiary in Johannesburg
- Reliable partners



Your ideas and requests are our inspiration.

Challenge us.

The GHM Messtechnik GmbH Group was founded in 2009. However, the history of the traditional brands that are bundled under the umbrella brand goes back much further. In its current formation as the GHM GROUP, the enterprise is still obligated to the shared philosophy of the founders: Absolute customer orientation, speed, and first-class product quality!

Innovation with method: An increasing number of tasks in terms of the global economy and in technology reach the limits of feasibility and beyond. We meet this challenge with a broad-based enterprise structure

The Centers of Competence under the umbrella of the GHM GROUP cover a wide range of market-specific solutions for all important areas of application with their respective areas of expertise.

With the GHM GROUP our customers benefit from over 200 years of combined experience. With this expertise, our engineers at the various "Centers of Competence" are quickly and flexibly in a position to develop solutions that meet the specific requirements of our customers and are in-line with market demand.

It is an advantage of our enterprise, which is unrivalled.

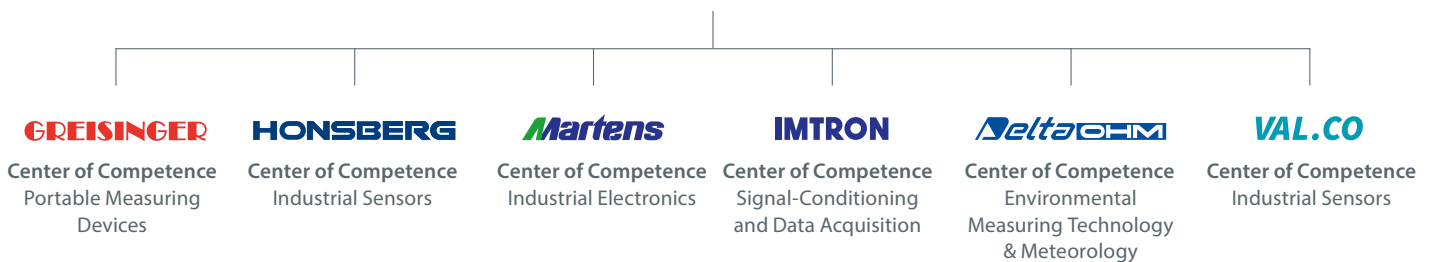

INDUSTRIAL

- Sensors for a variety of process variables such as temperature, flow, level and pressure
- Transmitters and isolators for various input/ output variables
- Indicators and controllers in various formats and performance classes



ENVIRONMENTAL

- Measuring stations for climate and environmental data with the connection to cloud-systems
- Mobile measurement technology for climate, water and gas analysis



TESTING & SERVICES

- Test bench measurement technology with up to 40,000 measurement in the secondary
- Stationary and mobile systems for universal use
- Modular systems for individual adaption to the process needs



Your direct contact to us



+49 2191 9672-0



info@ghm-group.de

Headquarters

GHM Messtechnik GmbH
GHM GROUP CORPORATE
Tenter Weg 2-8
42897 Remscheid | GERMANY
Phone +49 2191 9672-0
Fax +49 2191 9672-40
info@ghm-group.de
www.ghm-group.de

Center of Competence

GHM Messtechnik GmbH
GHM GROUP – Greisinger
Hans-Sachs-Straße 26
93128 Regenstein | GERMANY
Phone +49 9402 9383-52
Fax +49 9402 9383-33
info@greisinger.de
www.greisinger.de

GHM Messtechnik GmbH
GHM GROUP – Honsberg
Tenter Weg 2-8
42897 Remscheid | GERMANY
Phone +49 2191 9672-0
Fax +49 2191 9672-40
info@ghm-group.de
www.ghm-group.de

GHM Messtechnik GmbH
GHM GROUP – Martens
Kiebitzhörn 18
22885 Barsbüttel | GERMANY
Phone +49 40 67073-0
Fax +49 40 67073-288
info@ghm-group.de
www.ghm-group.de

GHM Messtechnik GmbH
GHM GROUP – Imtron
Carl-Benz-Straße 11
88696 Owingen | GERMANY
Phone +49 7551 9290-0
Fax +49 7551 9290-90
info@ghm-group.de
www.ghm-group.de

Delta OHM S.r.l. a socio unico
GHM GROUP – Delta OHM
Via Marconi 5
35030 Caselle di Selvazzano
Padova (PD) | ITALY
Phone +39 049 8977150
info@deltaohm.com
www.deltaohm.com

Valco srl
GHM GROUP – Val.co
Via Rovereto 9/11
20014 S. Ilario di Nerviano
Milano (MI) | ITALY
Phone +39 0331 53 59 20
valco@valco.it
www.valco.it

GHM GROUP International

Austria

GHM Messtechnik GmbH
Office Austria
Breitenseer Str. 76/1/36
1140 Vienna | AUSTRIA
Phone +43 660 7335603
a.froestl@ghm-messtechnik.de
www.ghm-group.de

Brazil & Latin America

GHM Messtechnik Do Brasil Ltda
Av. José de Souza Campos,
1073, cj 06 | Campinas, SP
13025 320 | BRAZIL
Phone +55 19 98275 0069
info@grupoghm.com.br

Czech Republic / Slovakia

GHM Greisinger s.r.o.
Ovci hajek 2 / 2153
158 00 Prague 5
Nové Butovice | CZECH REPUBLIC
Phone +420 251 613828
Fax +420 251 612607
info@greisinger.cz
www.greisinger.cz

Denmark

GHM Maaleteknik ApS
Maarslet Byvej 2
8320 Maarslet | DENMARK
Phone +45 646492-00
Fax +45 646492-01
info@ghm.dk
www.ghm.dk

France

GHM GROUP France SAS
Parc des Pivollez
9 Rue de Catalogne
69150 Décines (Lyon) | FRANCE
Phone +33 6 60 32 06 35
contact@ghm-group.fr
www.ghm-group.fr

India

GHM Messtechnik India Pvt Ltd.
209 | Udyog Bhavan
Sonowala Road | Gregaon (E)
Mumbai - 400 063 | INDIA
Phone +91 22 40236235
info@ghmgroup.in
www.ghmgroup.in

Italy

Sales Greisinger & Delta OHM
GHM GROUP – Delta OHM
Via Marconi 5
35030 Caselle di Selvazzano
Padova (PD) | ITALY
Phone +39 049 8977150
info@deltaohm.com

Italy

Sales Honsberg, Martens, Valco
GHM GROUP – Val.co
Via Rovereto 9/11
20014 S. Ilario di Nerviano
Milano (MI) | ITALY
Phone +39 0331 53 59 20
alessandro.perego@valco.it

Netherlands

GHM Meettechnik BV
Zeeltweg 30
3755 KA Eemnes
NETHERLANDS
Phone +31 35 53805-40
Fax +31 35 53805-41
info@ghm-nl.com
www.ghm-nl.com

South Africa

GHM Messtechnik SA (Pty) Ltd
16 Olivier Street
Verwoerdpark, Alberton 1453
SOUTH AFRICA
Phone +27 74 4590040
j.grobler@ghm-sa.co.za



Visit us: www.ghm-group.de